



Nemko Test Report: 52047RUS1

Applicant: Communication Components, Inc.
89 Leuning Street
2nd Floor
Hackensack, NJ 07606

**Equipment Under Test:
(E.U.T.)** DAC-850-125

In Accordance With: **FCC Part 22, Subpart H**
850 MHz Cellular Band Amplifier

Tested By: Nemko USA, Inc.
802 N. Kealy
Lewisville, TX
75057-3136

Authorized By: 
Tom Tidwell, Frontline Group Manager

Date: 25 November, 2005

Table of Contents

SECTION 1. SUMMARY OF TEST RESULTS3

SECTION 2. GENERAL EQUIPMENT SPECIFICATION.....5

SECTION 3. RF POWER OUTPUT7

SECTION 4. OCCUPIED BANDWIDTH.....8

SECTION 5. SPURIOUS EMISSIONS AT ANTENNA TERMINALS.....21

SECTION 6. FIELD STRENGTH OF SPURIOUS36

SECTION 7. TEST EQUIPMENT LIST.....39

ANNEX A - TEST DETAILS40

ANNEX B - TEST DIAGRAMS46

EQUIPMENT: DAC-850-125

Section 1. Summary of Test Results

Manufacturer: Communication Components, Inc.
Model No.: DAC-850-125
Serial No.: A006936

General: **All measurements are traceable to national standards.**

These tests were conducted on a sample of the equipment for the purpose of demonstrating compliance with FCC Part 22, Subpart H.

- | | | | |
|-------------------------------------|----------------------------|-------------------------------------|---------------------|
| <input checked="" type="checkbox"/> | New Submission | <input type="checkbox"/> | Production Unit |
| <input type="checkbox"/> | Class II Permissive Change | <input checked="" type="checkbox"/> | Pre-Production Unit |

THIS TEST REPORT RELATES ONLY TO THE ITEM(S) TESTED.

THE FOLLOWING DEVIATIONS FROM, ADDITIONS TO, OR EXCLUSIONS FROM THE TEST SPECIFICATIONS HAVE BEEN MADE. NONE

Nemko USA Inc. authorizes the above named company to reproduce this report provided it is reproduced in its entirety and for use by the company's employees only.

Any use which a third party makes of this report, or any reliance on or decisions to be made based on it, are the responsibility of such third parties. Nemko USA Inc. accepts no responsibility for damages, if any, suffered by any third party as a result of decisions made or actions based on this report. This report applies only to the items tested.

Summary Of Test Data

NAME OF TEST	PARA. NO.	SPEC.	RESULT
RF Power Output	22.913(a)	500W ERP	Complies
Occupied Bandwidth	22.917(c)	Input/Output	Complies
Spurious Emissions at Antenna Terminals	22.917	-13 dBm	Complies
Field Strength of Spurious Emissions	22.917	-13 dBm E.I.R.P.	Complies
Frequency Stability	22.355	1.5 ppm	NA

Footnotes

:

- (1) Device does not demodulate input RF. The device is a power amplifier unit designed to integrate into a BTS.

Measurement uncertainty for each test configuration is expressed to 95% probability.

.

Section 2. General Equipment Specification

Supply Voltage Input:	24 Vdc				
Frequency Range:	869.2 to 893.8 MHz				
	Note: At the highest and lowest channels, the power output must be reduced to 3 Watts for GSM and 5.8 Watts for EDGE modulations to achieve bandedge compliance.				
Type of Modulation and Designator:	CDMA (F9W) <input type="checkbox"/>	GSM (G7W) <input checked="" type="checkbox"/>	NADC (DXW) <input type="checkbox"/>	EDGE (G7W) <input checked="" type="checkbox"/>	AMPS (F8W, F1D) <input type="checkbox"/>
Output Impedance:	50 ohms				
RF Output (Rated):	Downlink:	Per Channel:	62.5	W	
		Total:	125	W	
	Uplink:	Per Channel:	NA	W	
		Total:	NA	W	
Frequency Translation:	F1-F1	F1-F2	N/A		
The device is simply an amplifier and does not translate the frequency.	<input type="checkbox"/>	<input type="checkbox"/>	<input checked="" type="checkbox"/>		
Band Selection:	Software	Duplexer Change	Fullband Coverage		
	<input type="checkbox"/>	<input type="checkbox"/>	<input checked="" type="checkbox"/>		

Description of Operation

The device is a base station amplifier operating in the 850 MHz cellular band utilizing GSM and GSM EDGE technology. Each input outputs 62.5 Watts single carrier only and input into a combiner prior to output. The device is rated at 125 Watts combined power. Operation on the lowest and highest defined channels requires a reduction in rf power output to 3 watts GSM and 5 watts for EDGE modulation.

System Diagram

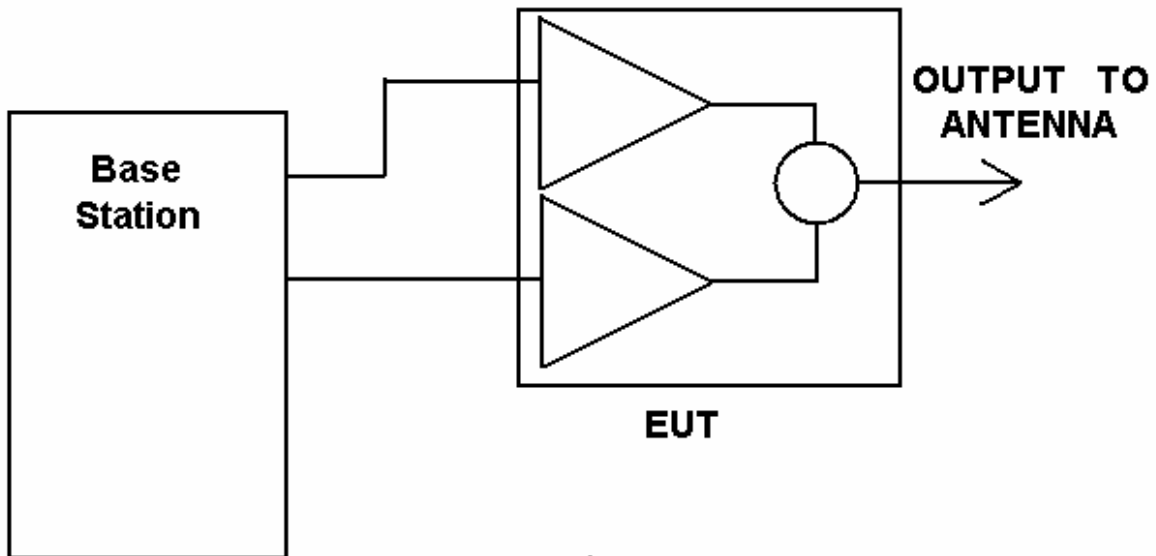

Section 3. RF Power Output

NAME OF TEST: RF Power Output	PARA. NO.: 2.1046
TESTED BY: David Light	DATE: 26 October 2005

Test Results: Complies.

Test Data:

Modulation Type	Per Channel Power Output (dBm)	Composite Power Output (dBm)	Per Channel Power Output (Watts)	Composite Power Output (Watts)
GSM	47.96	50.96	62.5	125
EDGE	47.96	50.96	62.5	125
GSM (Reduced)	34.8	-	3.0	-
EDGE (Reduced)	37.6	-	5.8	-

Note: RF power output must be reduced at 869.2 and 893.8 MHz (center of lowest and highest channels) to 3 Watts for GSM and 5.8 Watts for EDGE modulations to adhere to bandedge requirements.

Equipment Used: 1036-1053-1054-1064-1067-1060

Measurement Uncertainty: +/- 1.7 dB

Temperature: 20 °C

Relative Humidity: 30 %

Section 4. Occupied Bandwidth

NAME OF TEST: Occupied Bandwidth	PARA. NO.: 2.1049
TESTED BY: David Light	DATE: 26 October 2005

Test Results: Complies.

Test Data: See attached plots

Equipment Used: 1036-1053-1054-1064-1067-1060

**Measurement
Uncertainty:** +/- 1.7 dB

Temperature: 20 °C

**Relative
Humidity:** 30 %

Test Data – Occupied Bandwidth

GSM Output



Ref Lvl	Marker 1 [T1]	RBW	3 kHz	RF Att	30 dB
50 dBm	17.27 dBm	VBW	3 kHz		
	869.20000000 MHz	SWT	280 ms	Unit	dBm

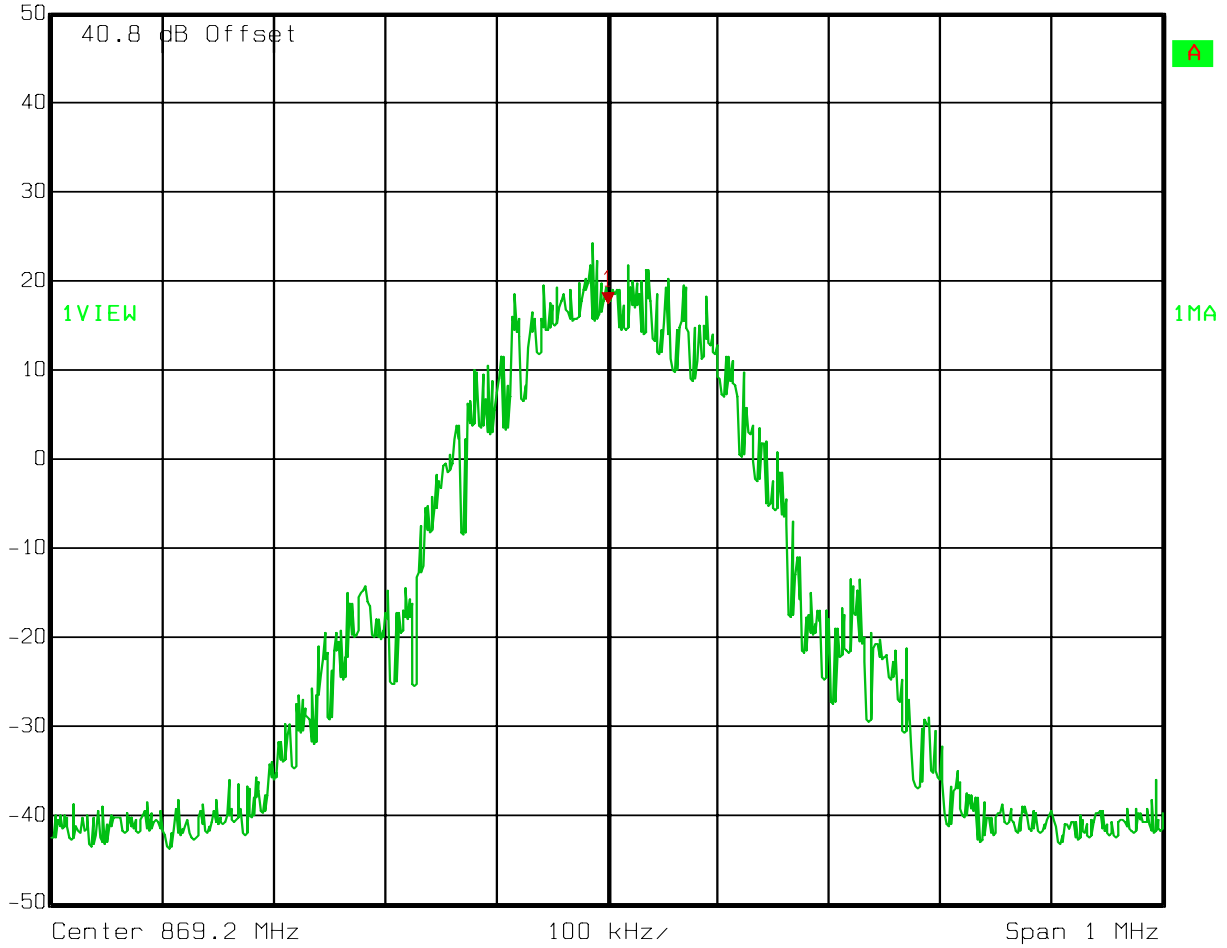

Date: 26.OCT.2005 14:39:41

EQUIPMENT: DAC-850-125

Test Data – Occupied Bandwidth

GSM Input



Ref Lvl
50 dBm

RBW	3 kHz	RF Att	30 dB
VBW	3 kHz		
SWT	280 ms	Unit	dBm

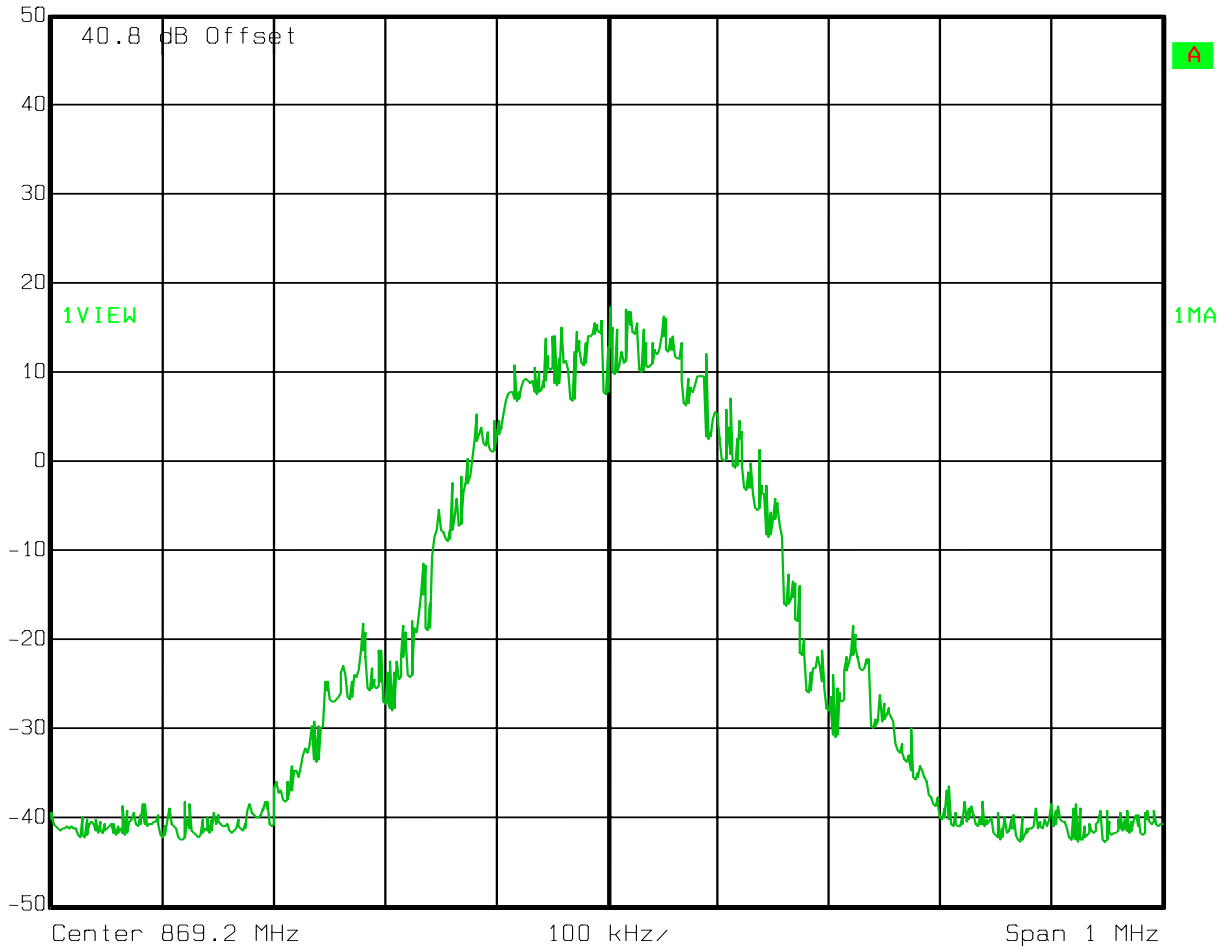

Date: 27.OCT.2005 08:30:48

Test Data – Occupied Bandwidth

GSM Output



Ref Lvl	50 dBm	Marker 1 [T1]	16.84 dBm	RBW	3 kHz	RF Att	30 dB
			893.80000000 MHz	VBW	3 kHz	Unit	dBm
				SWT	280 ms		

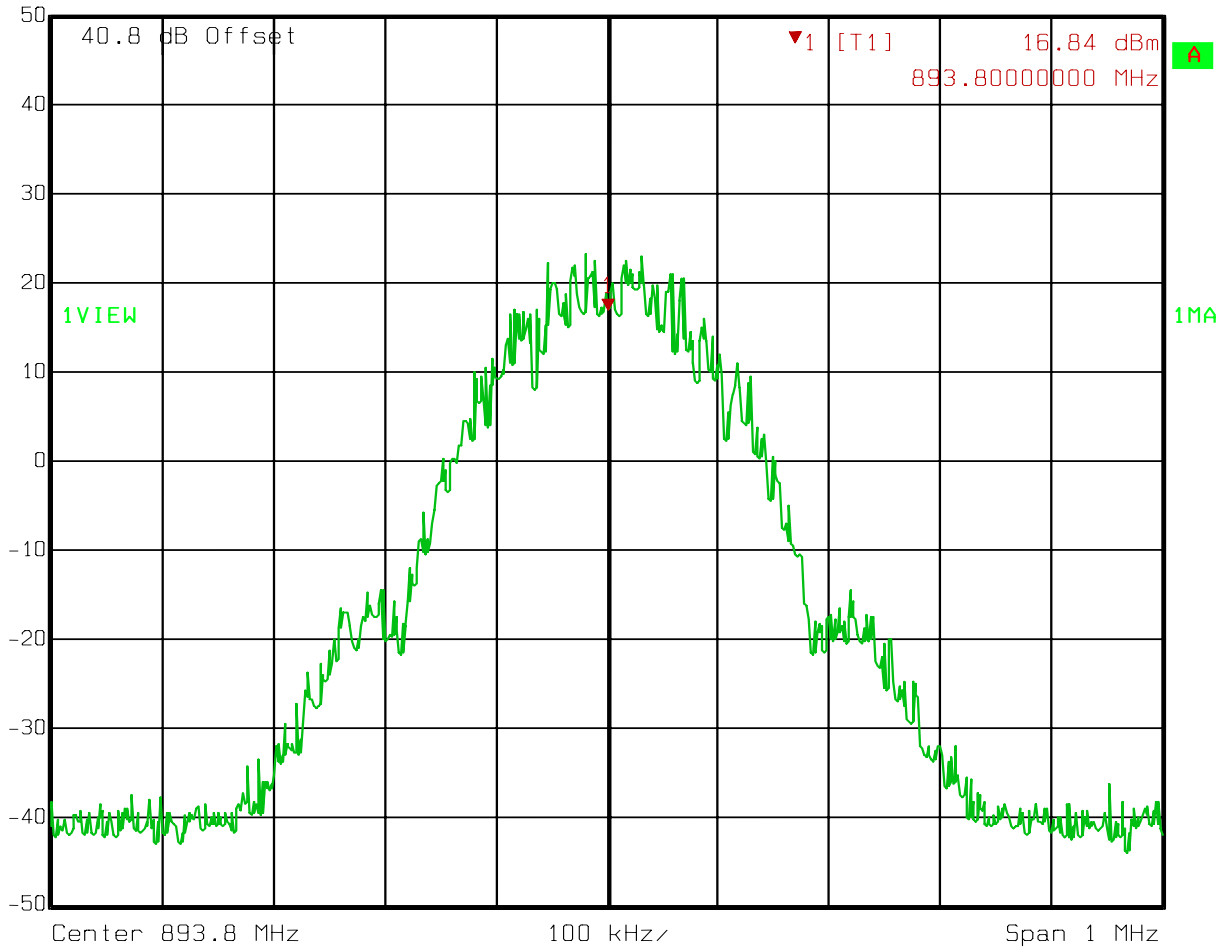

Date: 26.OCT.2005 14:52:34

Test Data – Occupied Bandwidth

GSM Input



Ref Lvl
50 dBm

RBW	3 kHz	RF Att	30 dB
VBW	3 kHz		
SWT	280 ms	Unit	dBm

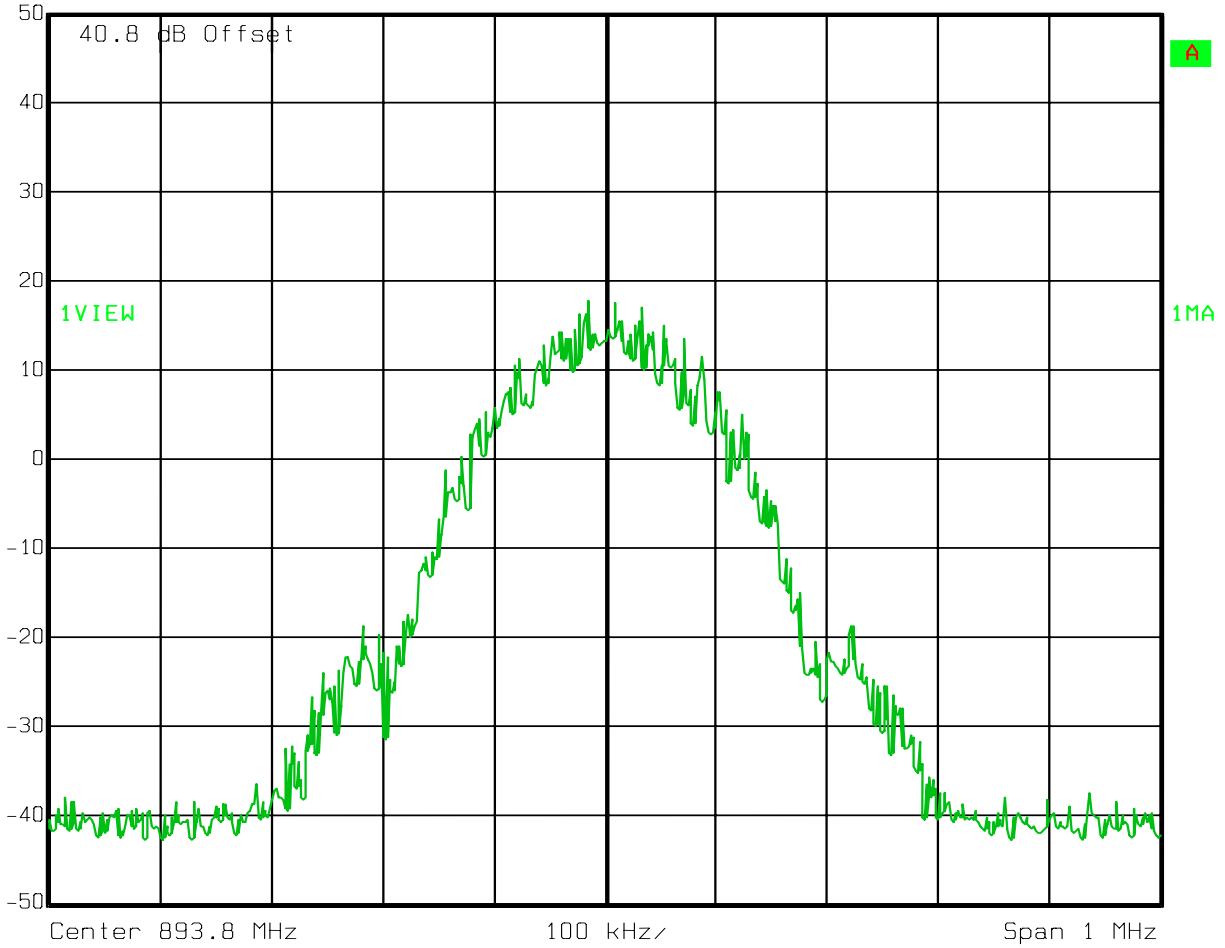

Date: 27.OCT.2005 08:30:05

Test Data – Occupied Bandwidth

GSM Output



Ref Lvl
50 dBm

RBW	3 kHz	RF Att	30 dB
VBW	3 kHz		
SWT	280 ms	Unit	dBm

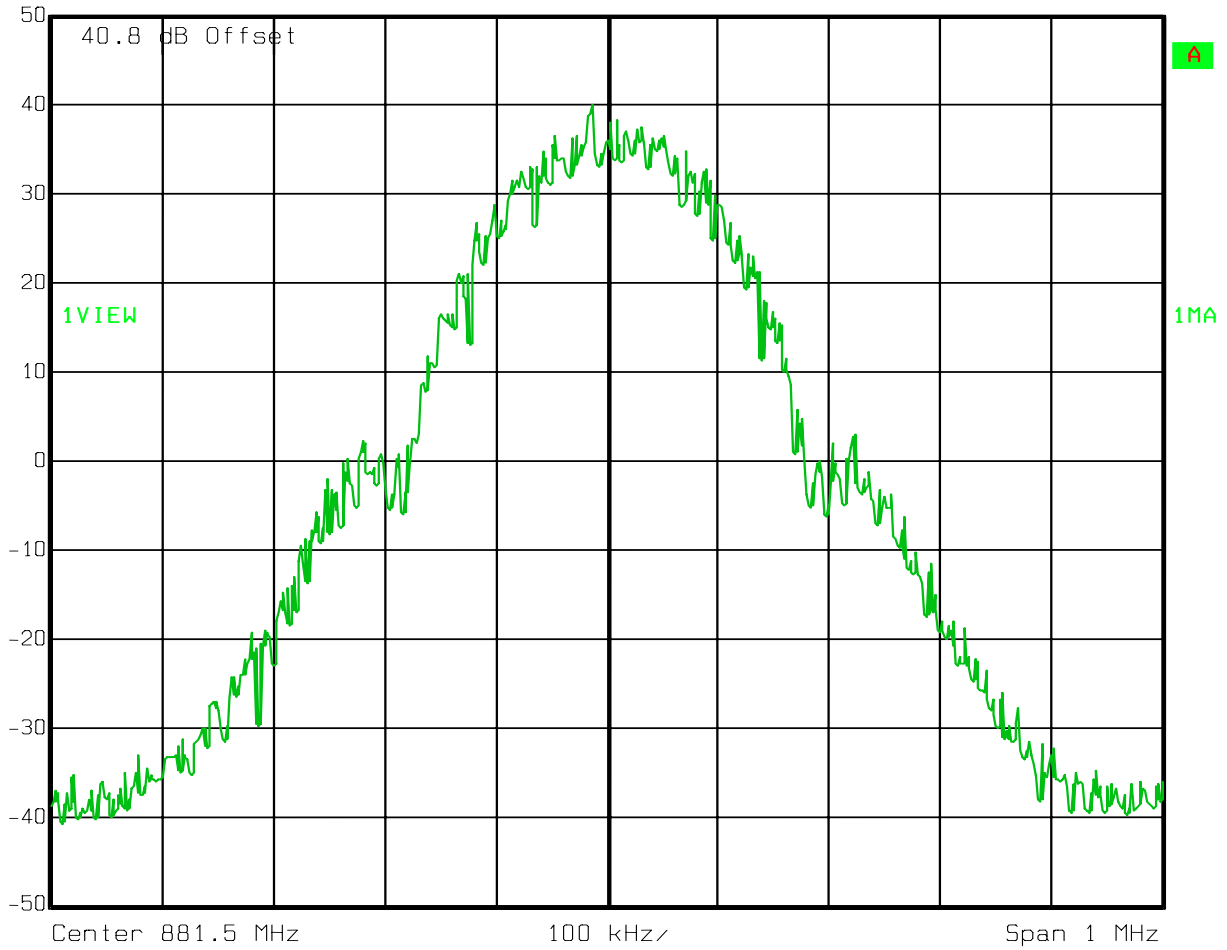

Date: 27.OCT.2005 08:27:15

Test Data – Occupied Bandwidth

GSM Input



Ref Lvl
50 dBm

RBW	3 kHz	RF Att	30 dB
VBW	3 kHz		
SWT	280 ms	Unit	dBm

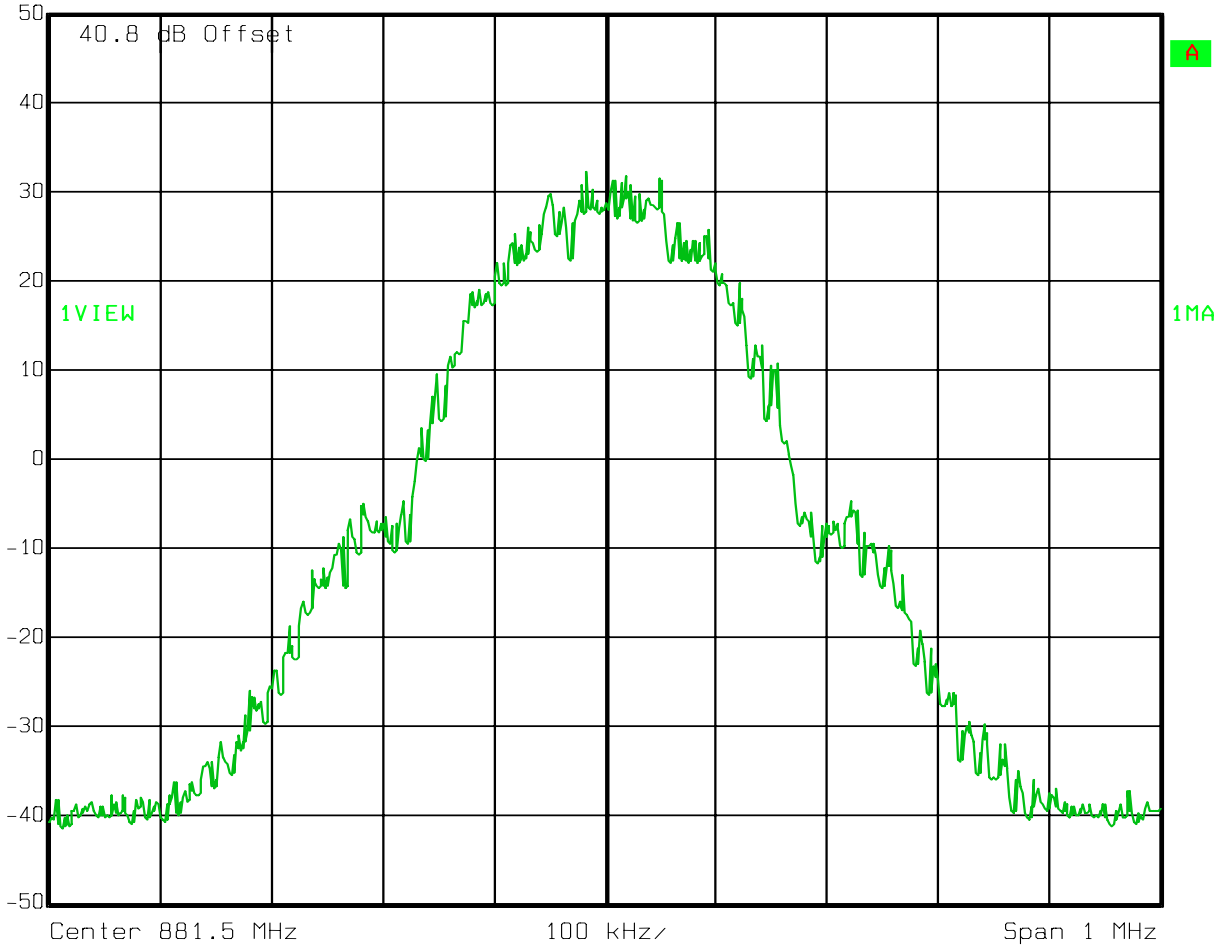

Date: 27.OCT.2005 08:28:49

Test Data – Occupied Bandwidth

EDGE Output



Ref Lvl
50 dBm

RBW	3 kHz	RF Att	30 dB
VBW	3 kHz		
SWT	280 ms	Unit	dBm

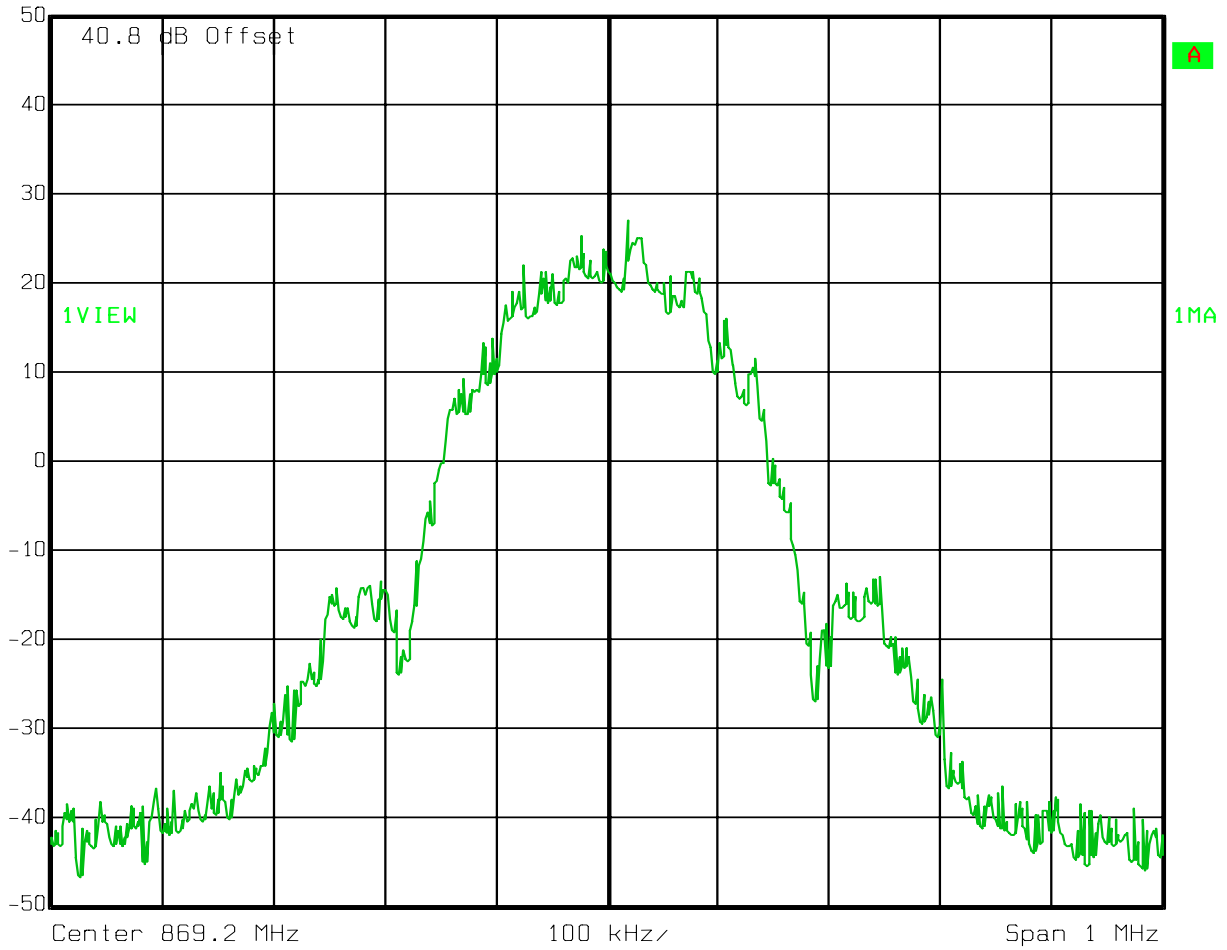

Date: 27.OCT.2005 08:46:03

Test Data – Occupied Bandwidth

EDGE Input



Ref Lvl
50 dBm

RBW	3 kHz	RF Att	30 dB
VBW	3 kHz		
SWT	280 ms	Unit	dBm

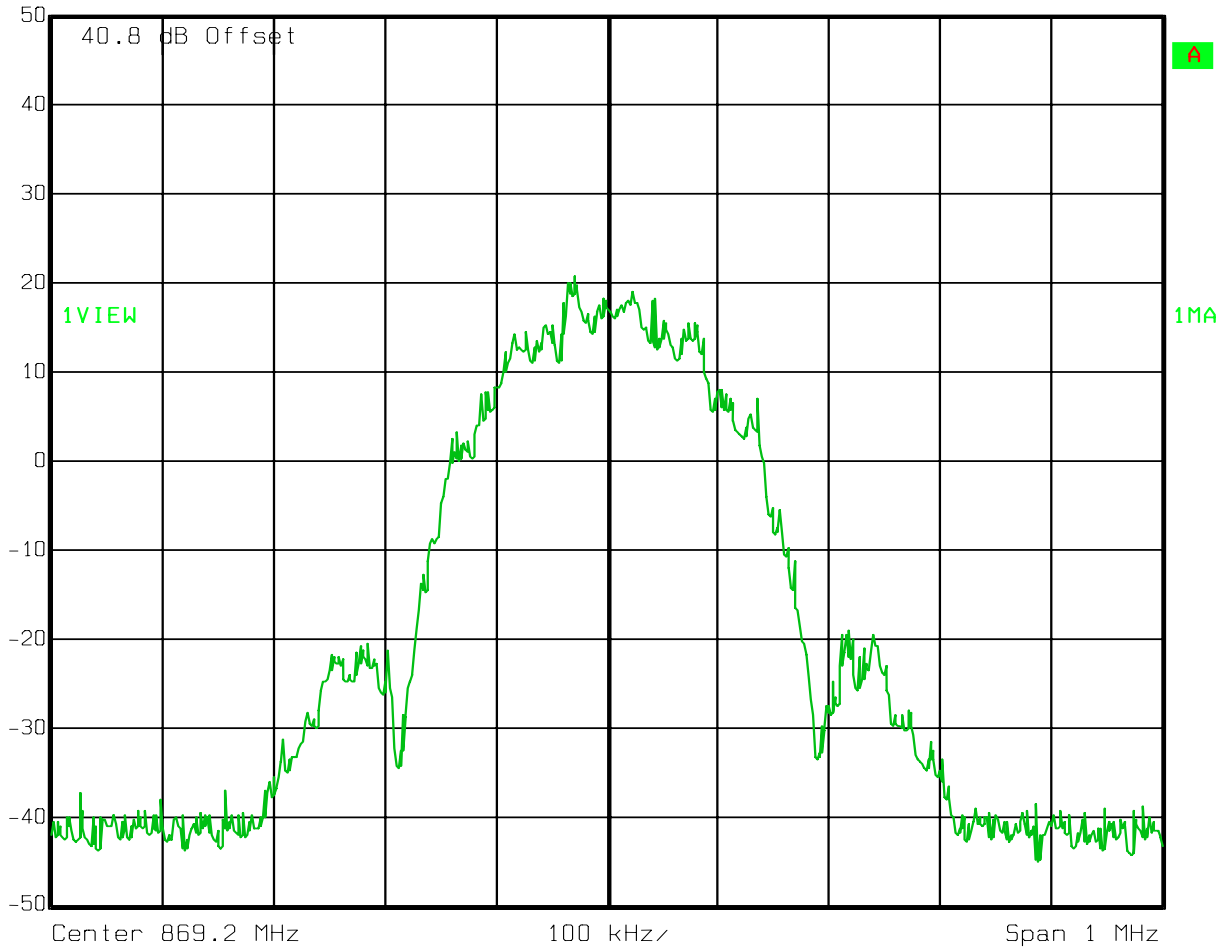

Date: 27.OCT.2005 09:02:12

Test Data – Occupied Bandwidth

EDGE Output



Ref Lvl
50 dBm

RBW 3 kHz RF Att 30 dB
VBW 3 kHz
SWT 280 ms Unit dBm

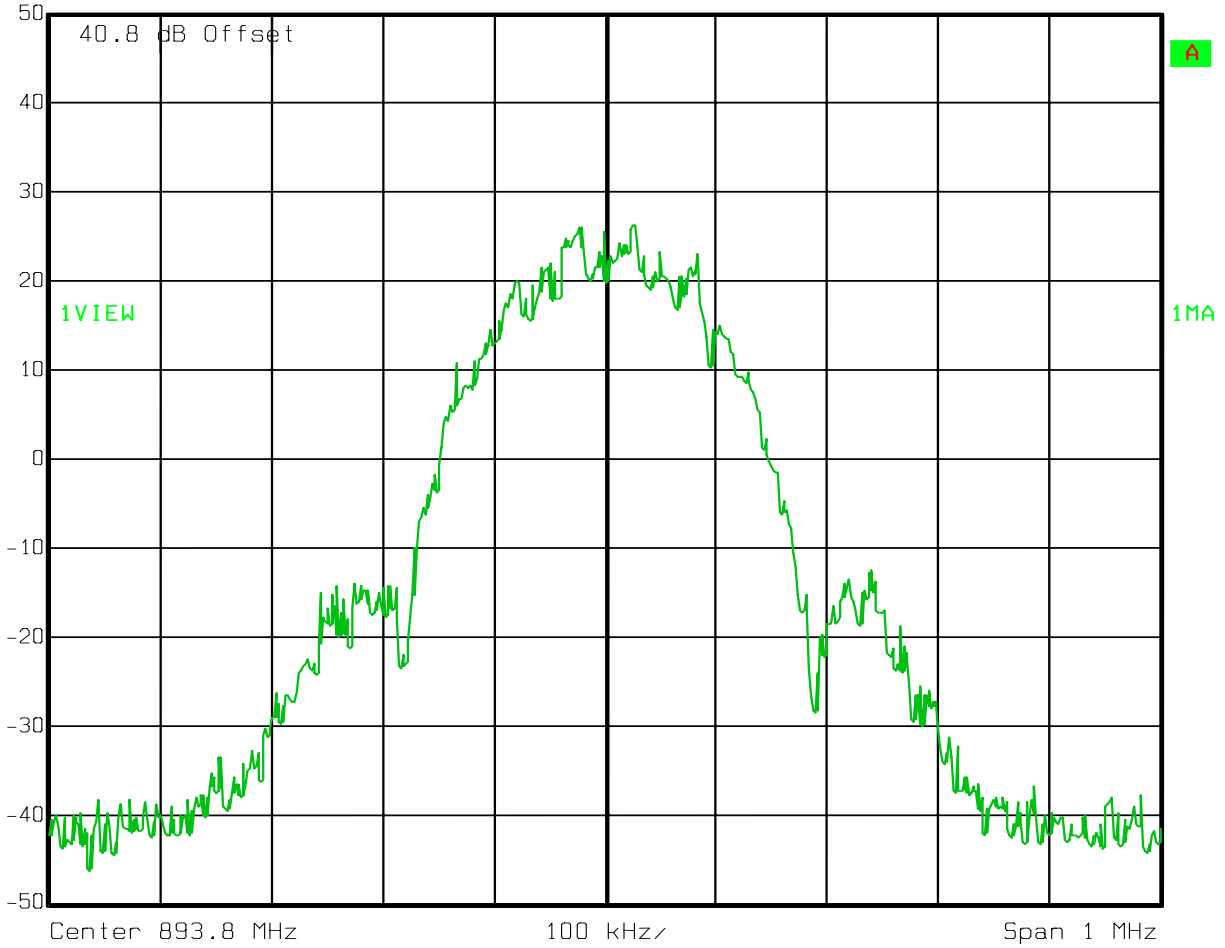

Date: 27.OCT.2005 08:50:30

Test Data – Occupied Bandwidth

EDGE Input



Ref Lvl
50 dBm

RBW	3 kHz	RF Att	30 dB
VBW	3 kHz		
SWT	280 ms	Unit	dBm

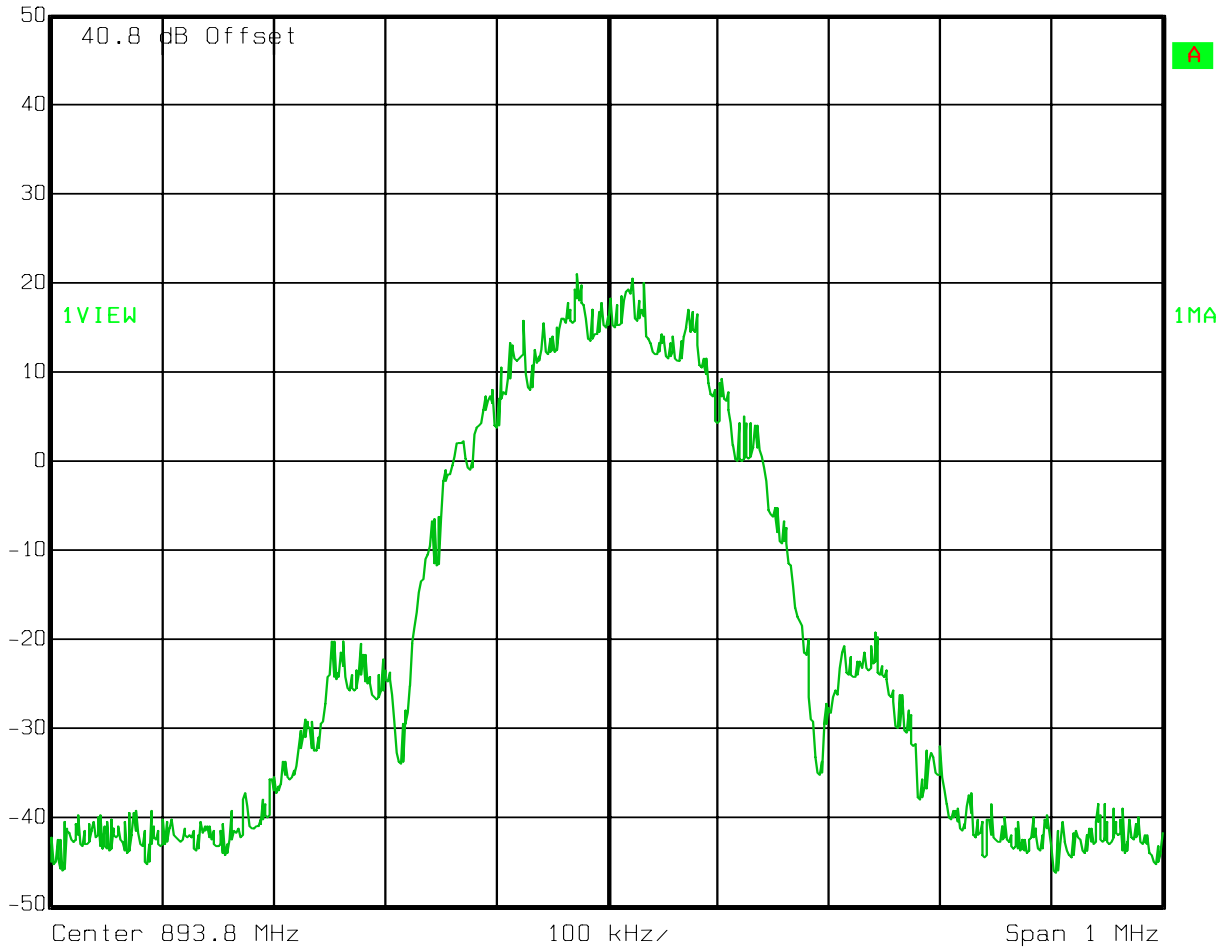

Date: 27.OCT.2005 09:01:29

Test Data – Occupied Bandwidth

EDGE Output



Ref Lvl
50 dBm

RBW	3 kHz	RF Att	30 dB
VBW	3 kHz		
SWT	280 ms	Unit	dBm

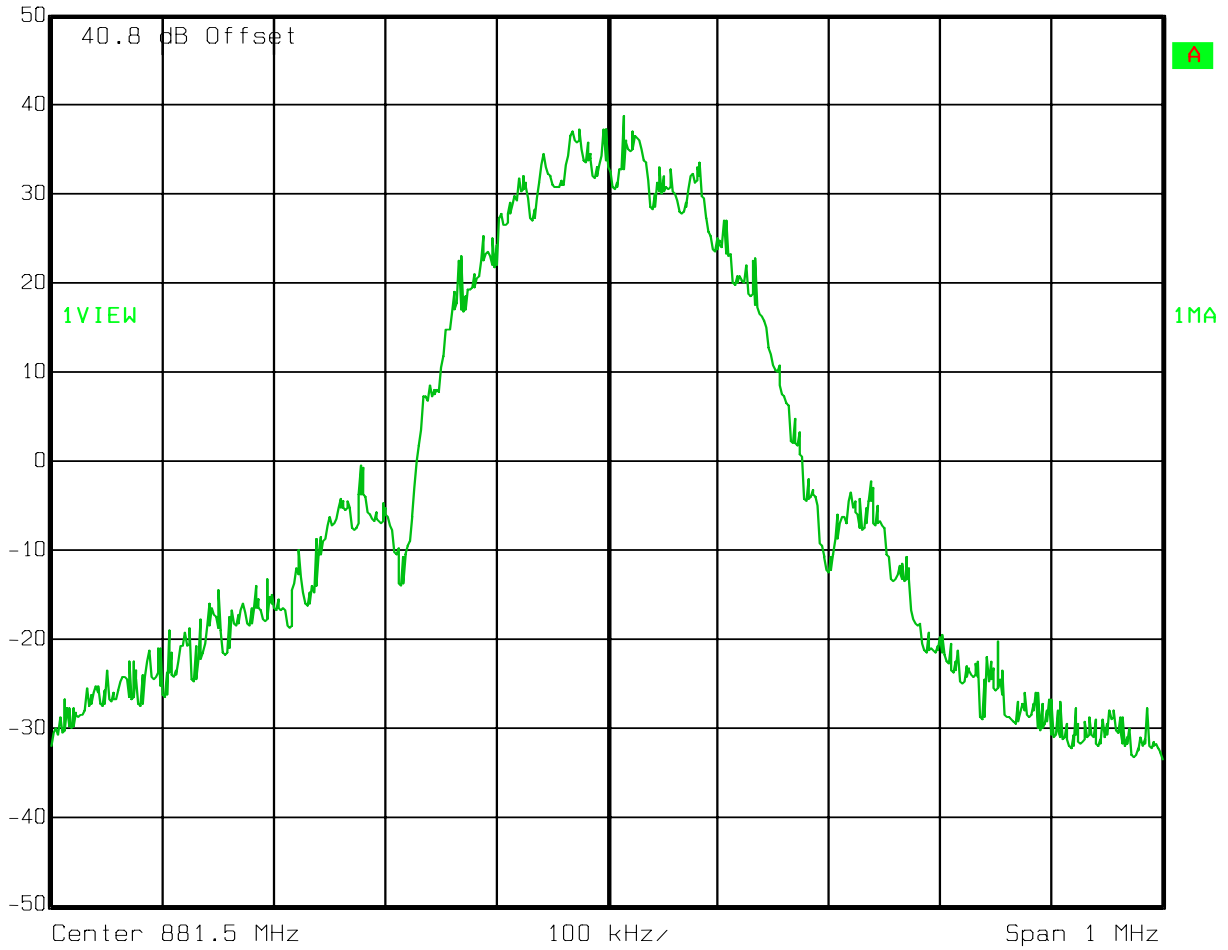

Date: 27.OCT.2005 08:58:54

EQUIPMENT: DAC-850-125

Test Data – Occupied Bandwidth

EDGE Input



Ref Lvl
50 dBm

RBW	3 kHz	RF Att	30 dB
VBW	3 kHz		
SWT	280 ms	Unit	dBm

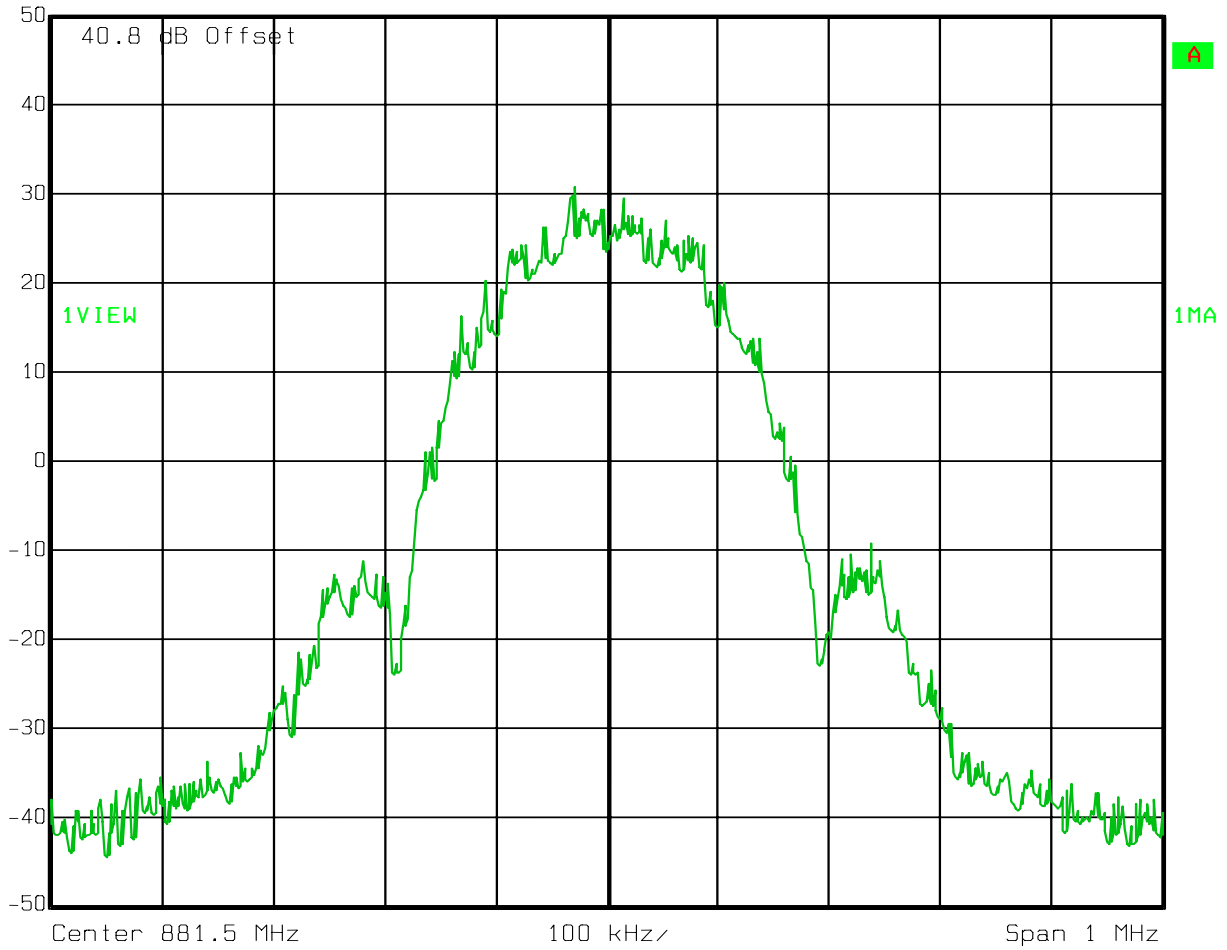

Date: 27.OCT.2005 09:00:33

Section 5. Spurious Emissions at Antenna Terminals

NAME OF TEST: Spurious Emissions @ Antenna Terminals	PARA. NO.: 2.1051
TESTED BY: David Light	DATE: 26 October 2005

Test Results: Complies.

Test Data: See attached plots

Equipment Used: 1036-1053-1054-1064-1067-1060

Measurement Uncertainty: +/- 1.7 dB

Temperature: 20 °C

Relative Humidity: 30 %

EQUIPMENT: DAC-850-125

Test Data – Spurious Emissions at Antenna Terminals

Low band edge – 869.2 MHz @ 3 watts

GSM



Ref Lvl	Marker 1 [T1]	RBW	3 kHz	RF Att	30 dB
50 dBm	19.88 dBm	VBW	3 kHz		
	869.20000000 MHz	SWT	280 ms	Unit	dBm

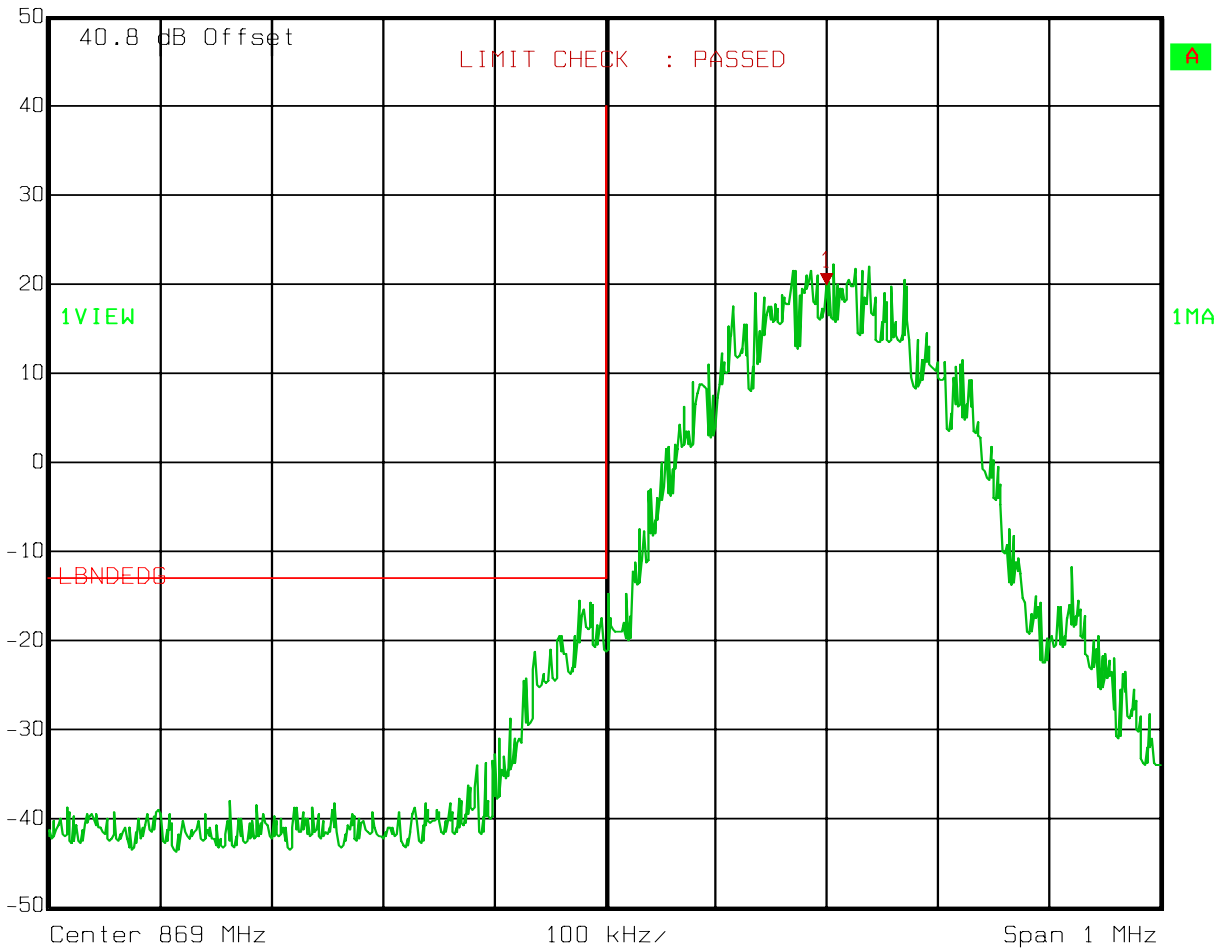

Date: 26.OCT.2005 14:37:27

EQUIPMENT: DAC-850-125

Test Data – Spurious Emissions at Antenna Terminals

Lower band edge IM – Two carriers at 62.5 watts each

GSM

RS Marker 2 [T1] RBW 3 kHz RF Att 30 dB
Ref Lvl 36.43 dBm VBW 3 kHz
50 dBm 869.9000000 MHz SWT 560 ms Unit dBm

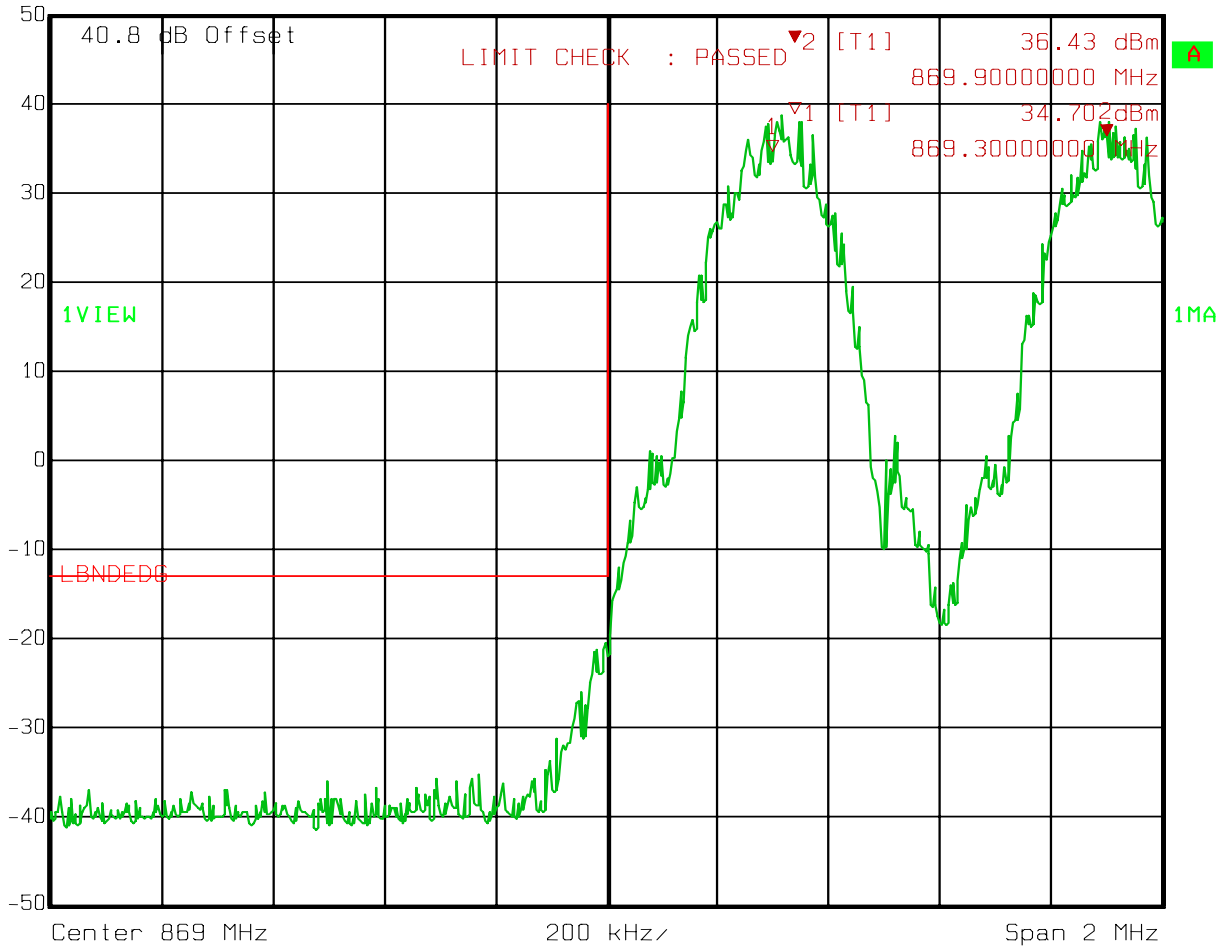

Date: 26.OCT.2005 14:47:31

Test Data – Spurious Emissions at Antenna Terminals

893.8 MHz at 3 watts output

GSM

RS Marker 1 [T1] RBW 3 kHz RF Att 30 dB
Ref Lvl 22.20 dBm VBW 3 kHz
50 dBm 893.8000000 MHz SWT 280 ms Unit dBm

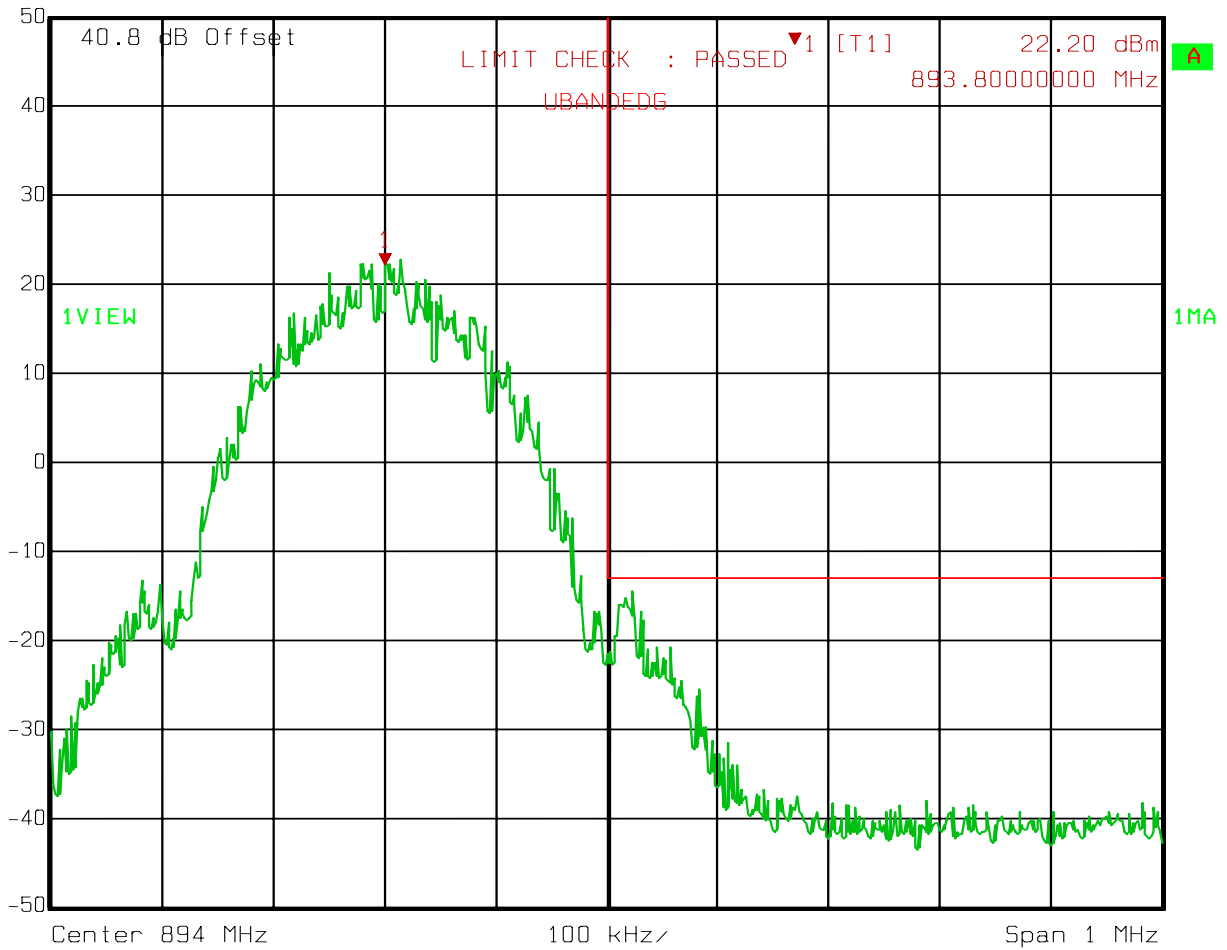

Date: 26.OCT.2005 14:51:42

Test Data – Spurious Emissions at Antenna Terminals

Lower band edge IM – Two channels at 62.5 watts each

GSM

 Ref Lvl 50 dBm Marker 2 [T1] 35.88 dBm RBW 3 kHz RF Att 30 dB
VBW 3 kHz Unit dBm
SWT 560 ms

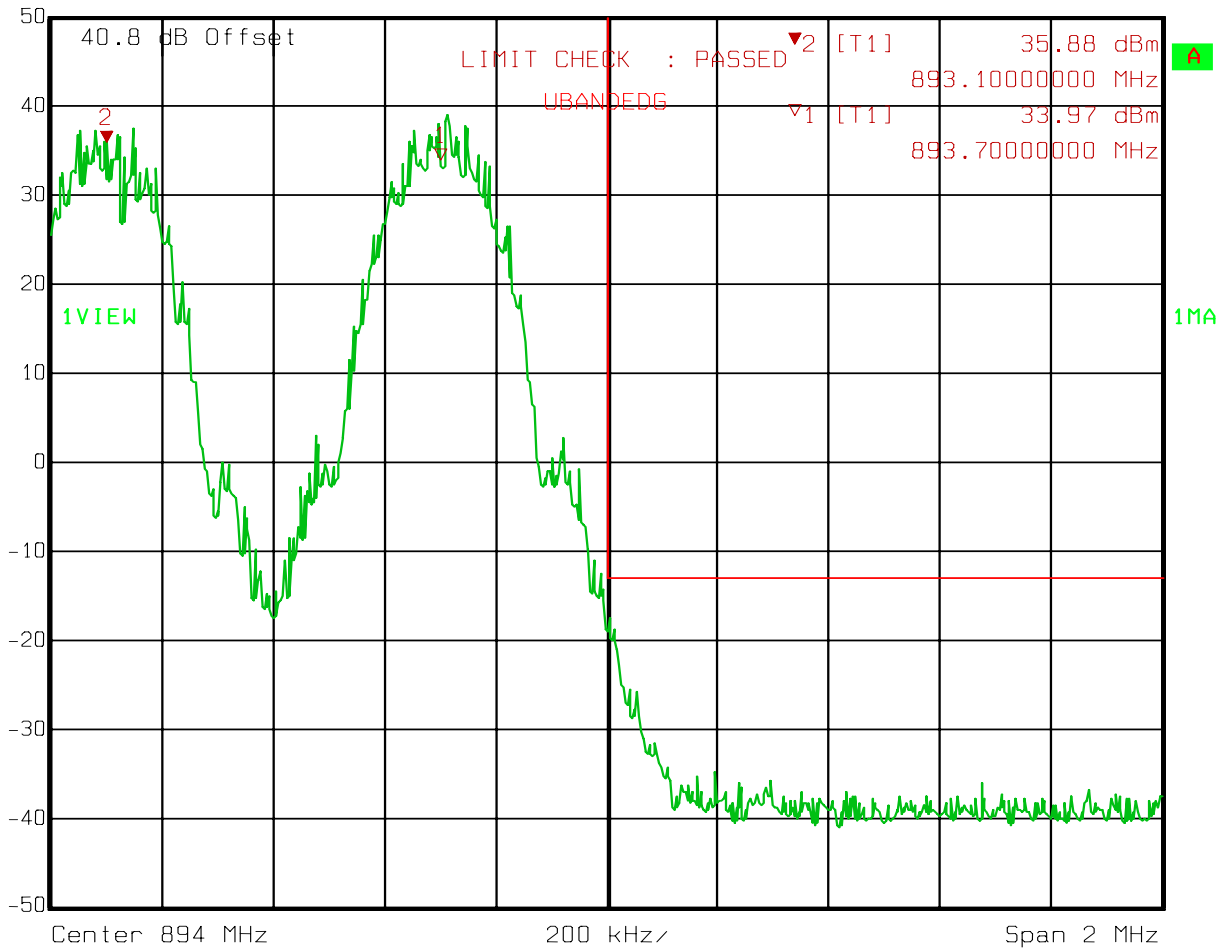

Date: 26.OCT.2005 14:55:28

Test Data – Spurious Emissions at Antenna Terminals

GSM



Marker 2 [T1] RBW 300 kHz RF Att 30 dB
Ref Lvl -15.25 dBm VBW 300 kHz
50 dBm 951.40280561 MHz SWT 27 ms Unit dBm

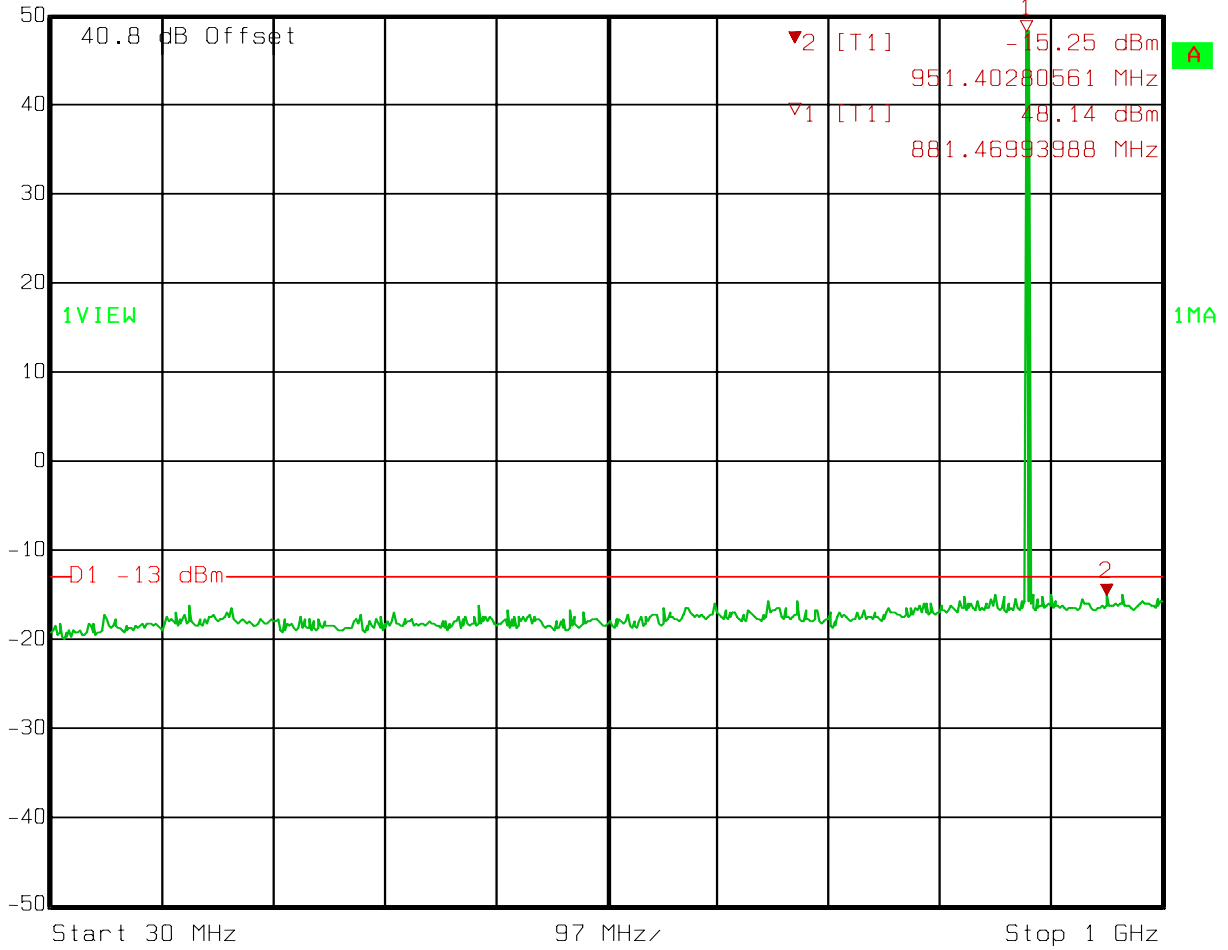

Date: 26.OCT.2005 14:59:20

Test Data – Spurious Emissions at Antenna Terminals

GSM

Ref Lvl 30.2 dBm
Marker 2 [T1] -23.84 dBm
2.64729459 GHz
RBW 1 MHz RF Att 10 dB
VBW 1 MHz
SWT 7.5 ms Unit dBm

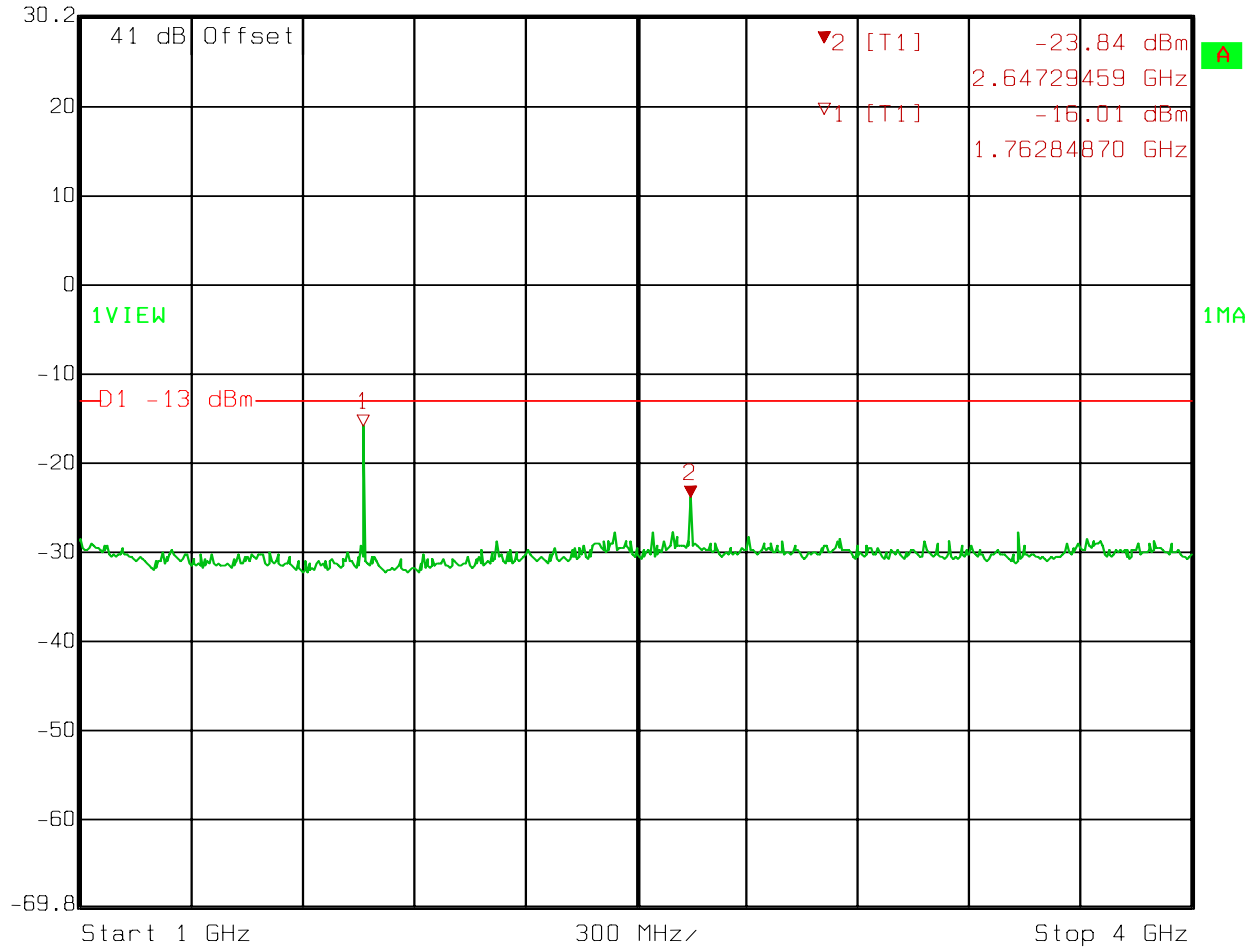

Date: 27.OCT.2005 09:19:20

Test Data – Spurious Emissions at Antenna Terminals

GSM

 Marker 1 [T1] RBW 1 MHz RF Att 10 dB
Ref Lvl -22.28 dBm VBW 1 MHz
32.2 dBm 6.51503006 GHz SWT 50 ms Unit dBm

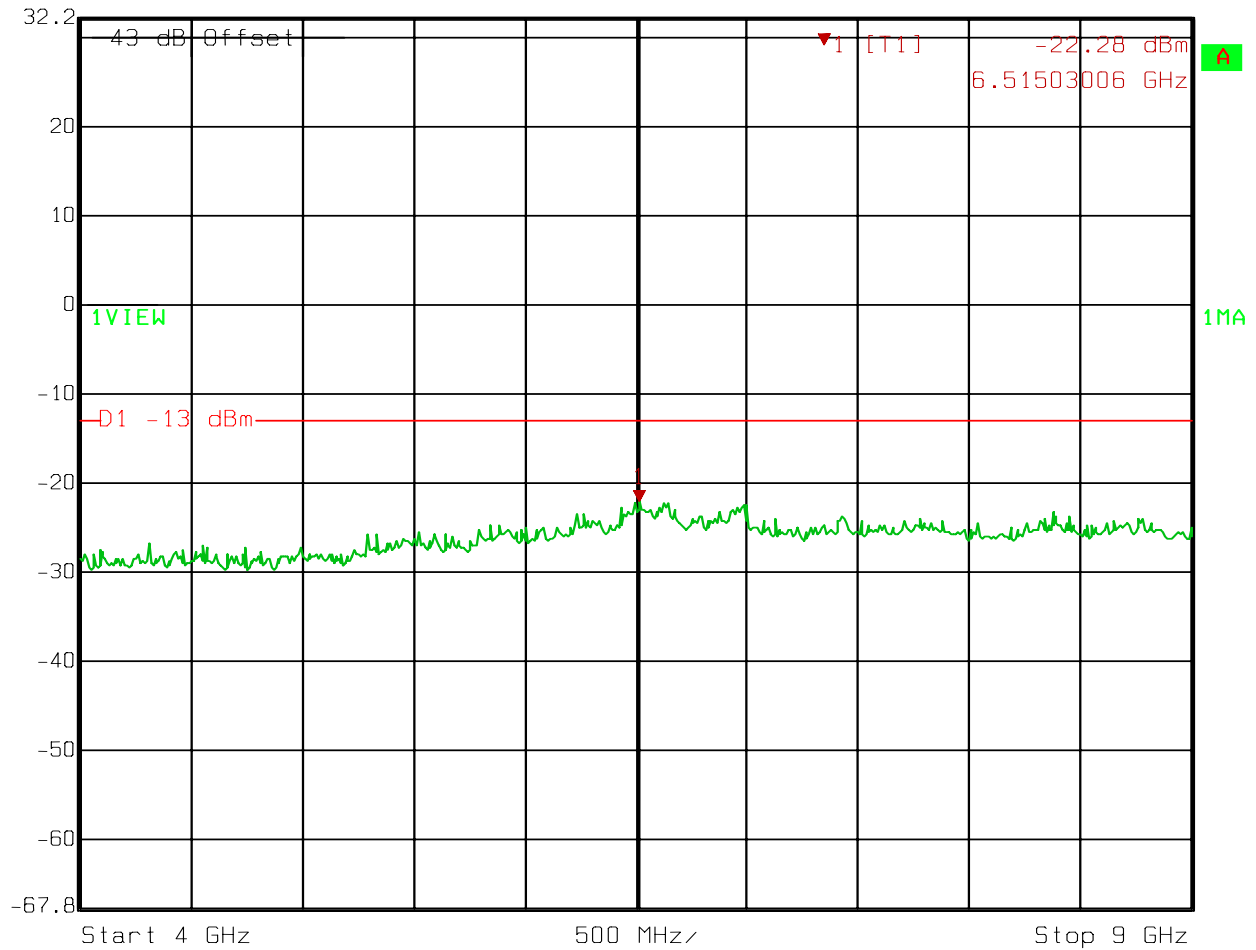

Date: 27.OCT.2005 09:25:49

The spectrum was investigated on three channels. The data presented is representative of all channels tested.

Test Data – Spurious Emissions at Antenna Terminals

EDGE

Lowest channel - 5.8 watts

RS Marker 1 [T1] RBW 3 kHz RF Att 30 dB
Ref Lvl 18.56 dBm VBW 3 kHz
50 dBm 869.20000000 MHz SWT 280 ms Unit dBm

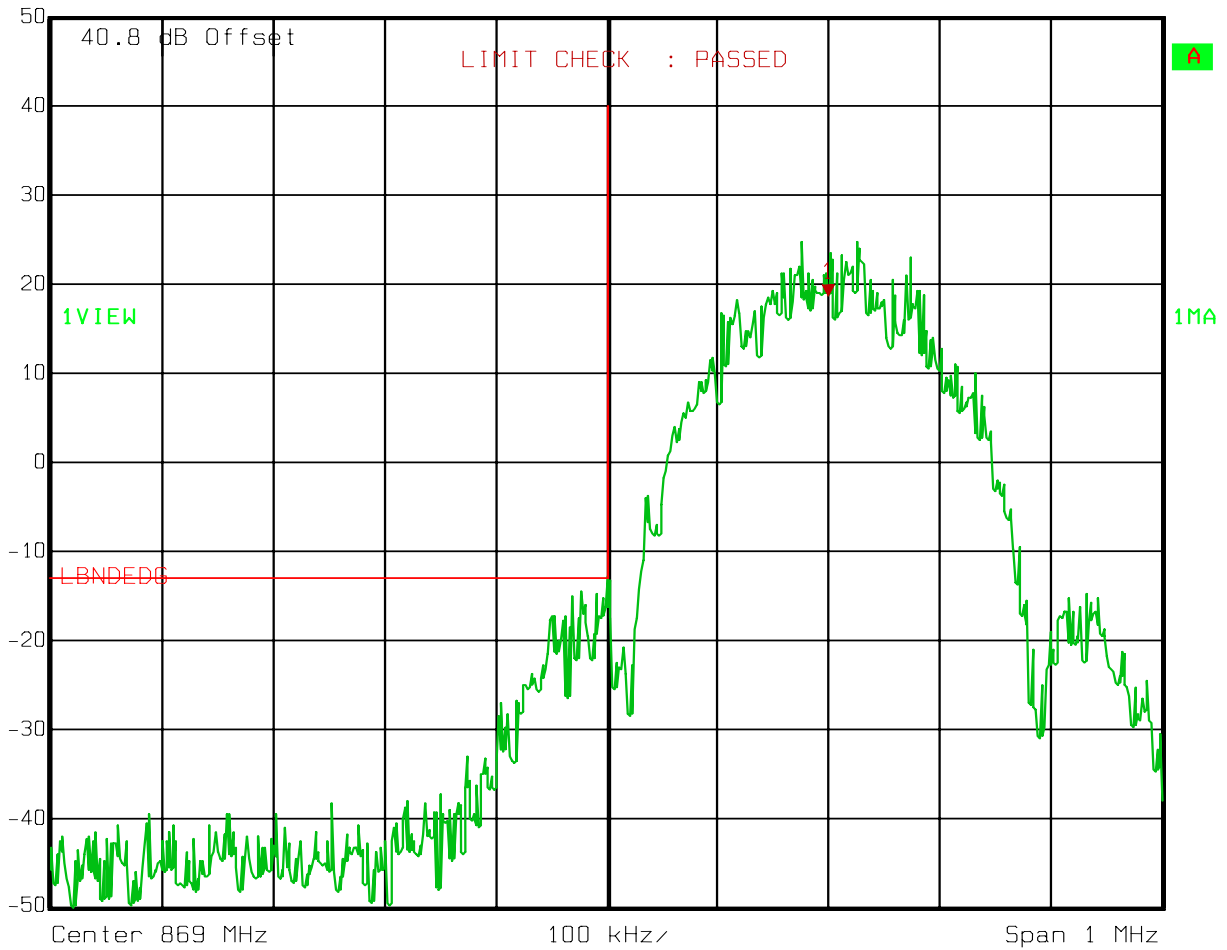

Date: 27.OCT.2005 08:39:34

EQUIPMENT: DAC-850-125

Test Data – Spurious Emissions at Antenna Terminals

EDGE

Two channels at 62.5 watts each

Marker 2 [T1] RBW 3 kHz RF Att 30 dB
Ref Lvl 35.75 dBm VBW 3 kHz
50 dBm 869.90000000 MHz SWT 560 ms Unit dBm

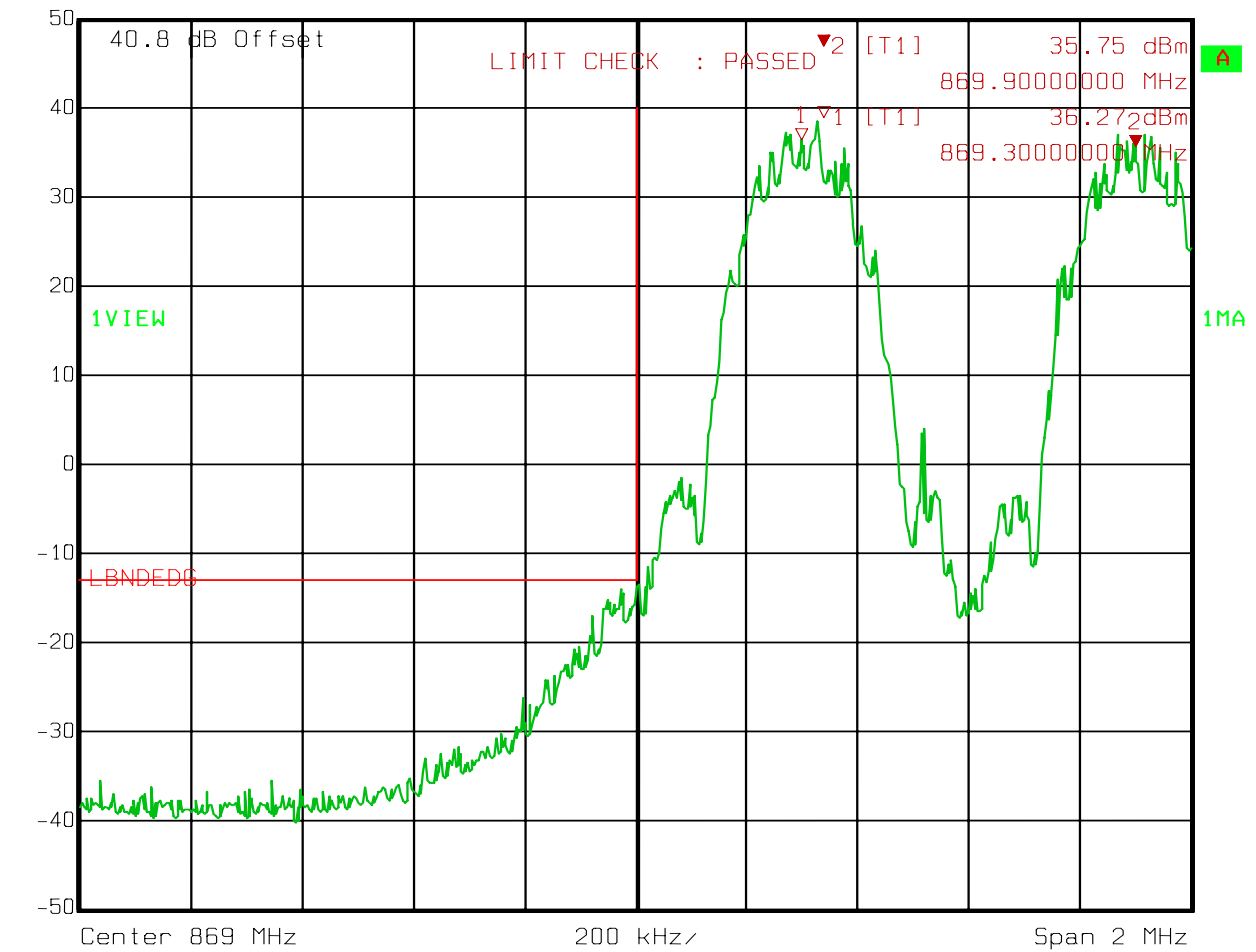

Date: 27.OCT.2005 08:44:13

Test Data – Spurious Emissions at Antenna Terminals

EDGE

Highest channel – 5.8 watts

Marker 1 [T1] RBW 3 kHz RF Att 30 dB
Ref Lvl 22.28 dBm VBW 3 kHz
50 dBm 893.8000000 MHz SWT 280 ms Unit dBm

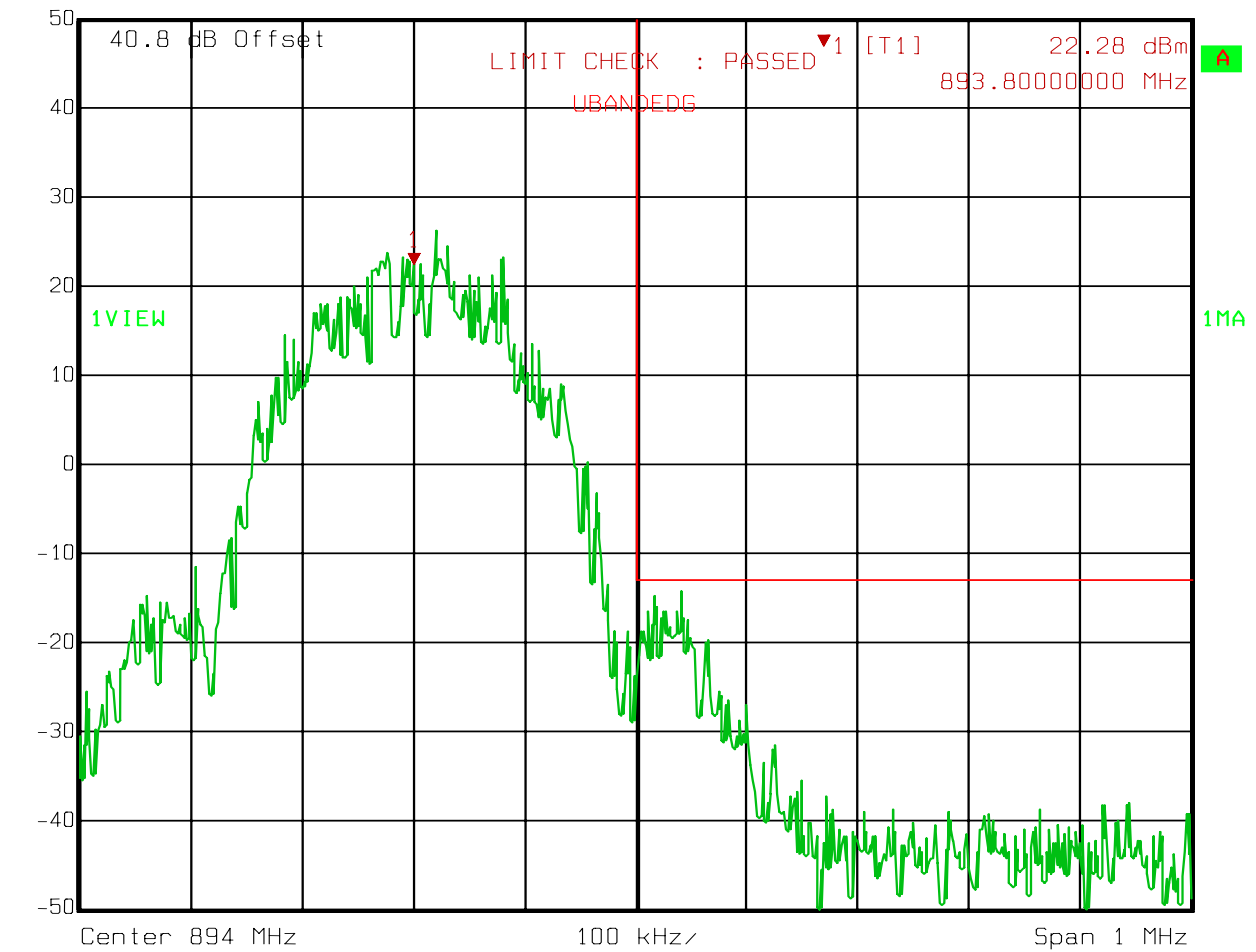

Date: 27.OCT.2005 08:48:58

Test Data – Spurious Emissions at Antenna Terminals

EDGE

Two channels – 62.5 watts each

Ref Lvl 50 dBm
Marker 2 [T1] 33.97 dBm
893.10000000 MHz
RBW 3 kHz RF Att 30 dB
VBW 3 kHz
SWT 560 ms Unit dBm

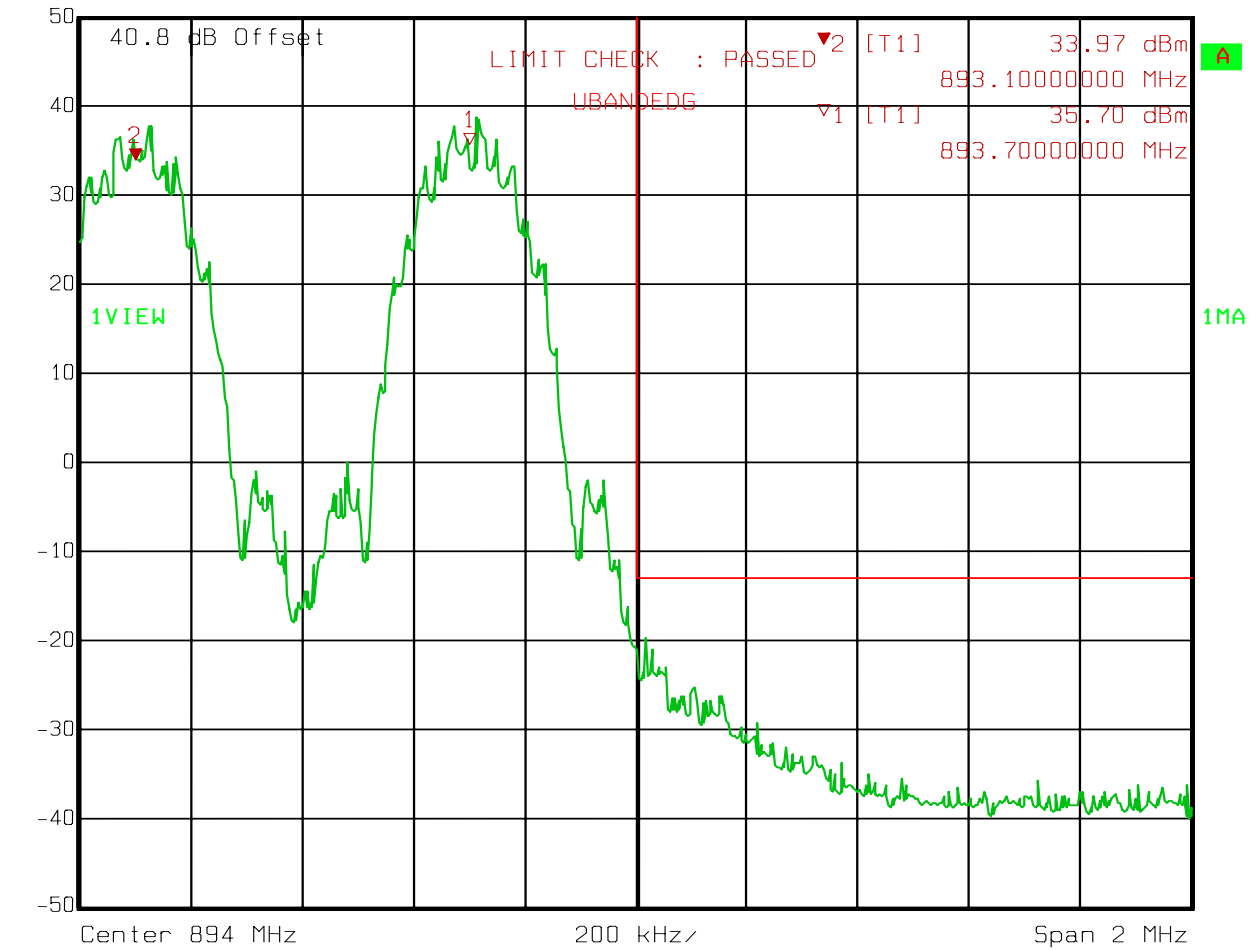

Date: 27.OCT.2005 08:53:25

Test Data – Spurious Emissions at Antenna Terminals

EDGE

 Marker 2 [T1] RBW 300 kHz RF Att 30 dB
Ref Lvl -15.03 dBm VBW 300 kHz
50 dBm 992.22444890 MHz SWT 27 ms Unit dBm

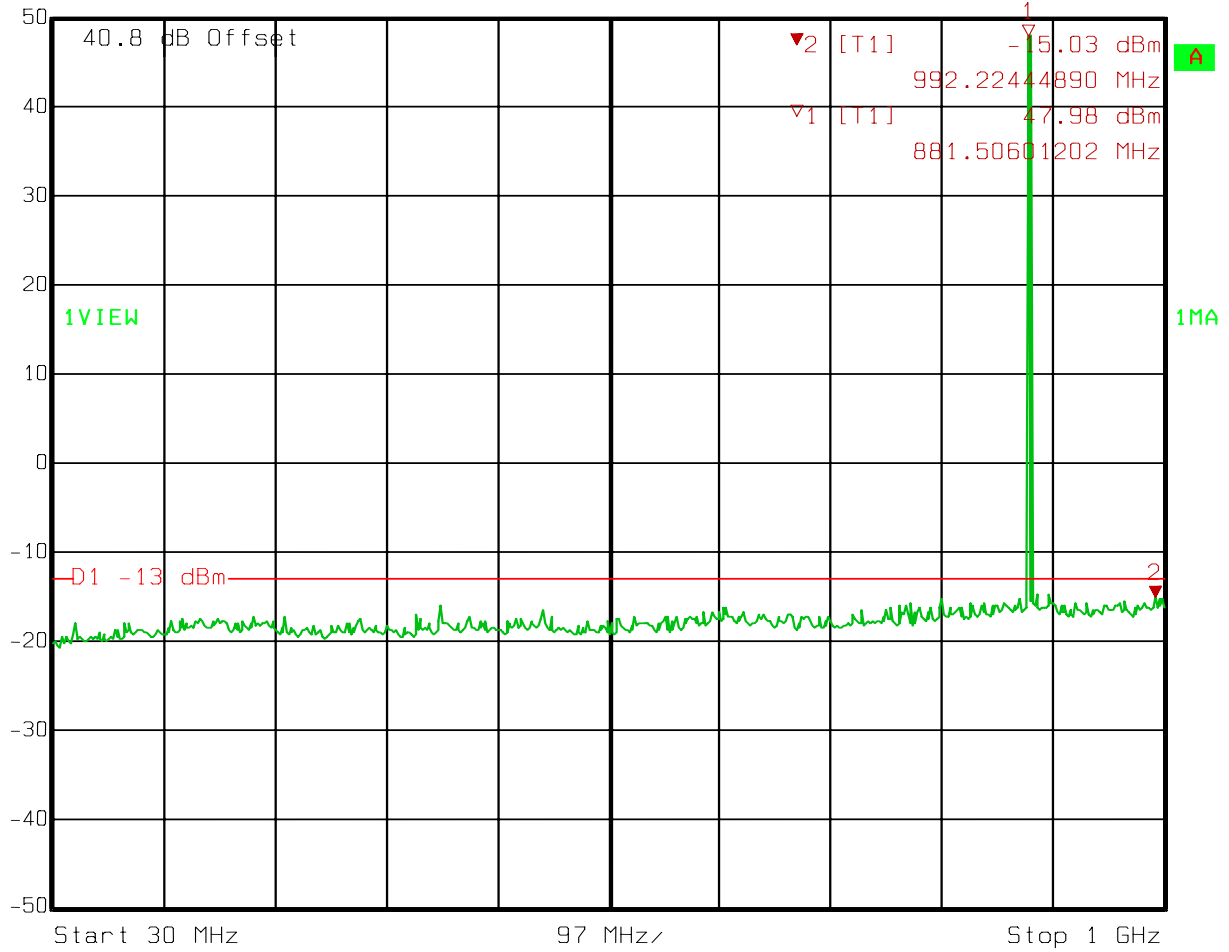

Date: 27.OCT.2005 08:56:47

Test Data – Spurious Emissions at Antenna Terminals

EDGE

Ref Lvl 30.2 dBm
Marker 2 [T1] -26.19 dBm
2.64729459 GHz
RBW 1 MHz RF Att 10 dB
VBW 1 MHz
SWT 7.5 ms Unit dBm

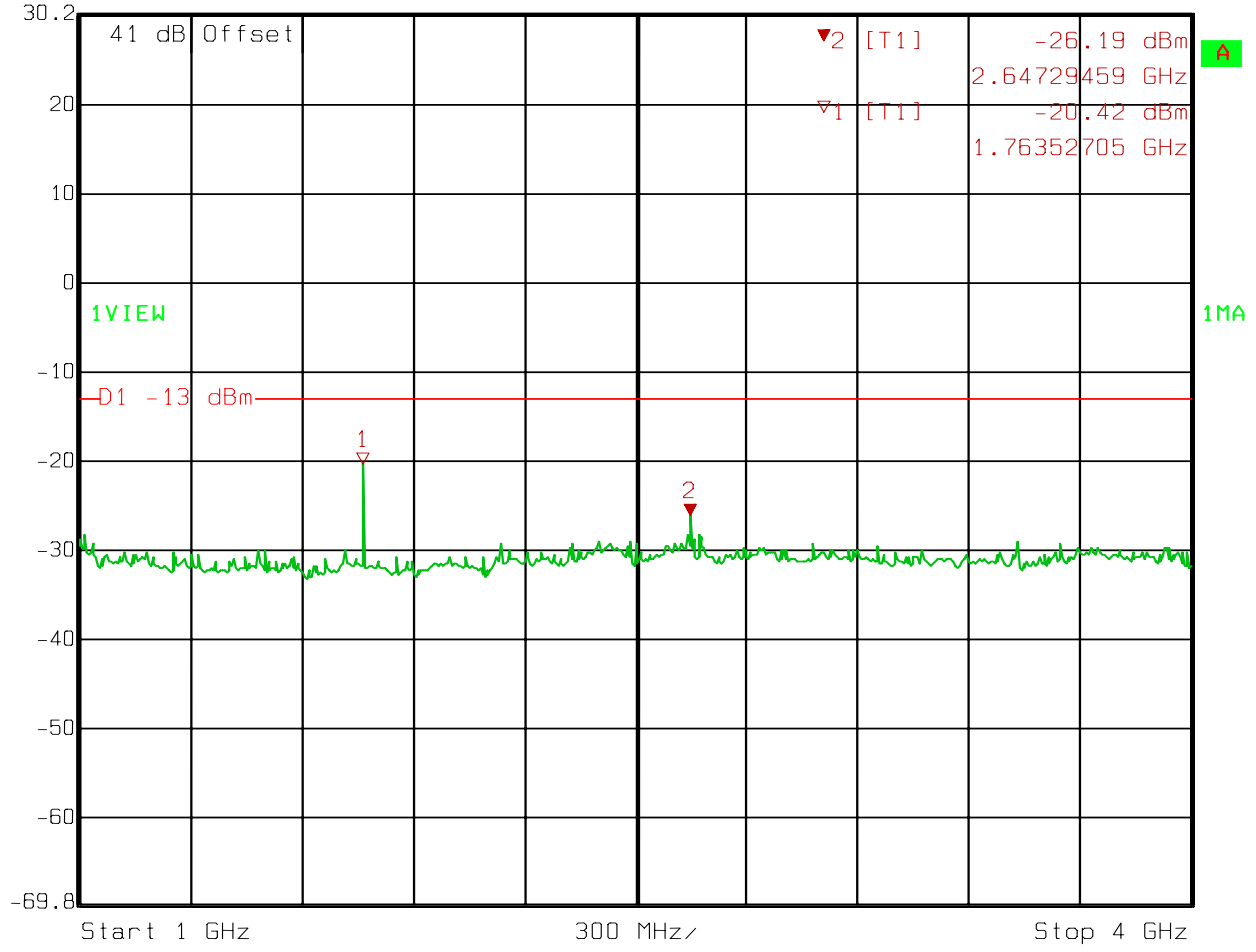

Date: 27.OCT.2005 09:33:48

Test Data – Spurious Emissions at Antenna Terminals

EDGE

 Marker 1 [T1] RBW 1 MHz RF Att 10 dB
Ref Lvl -22.15 dBm VBW 1 MHz
32.2 dBm 6.59519038 GHz SWT 50 ms Unit dBm

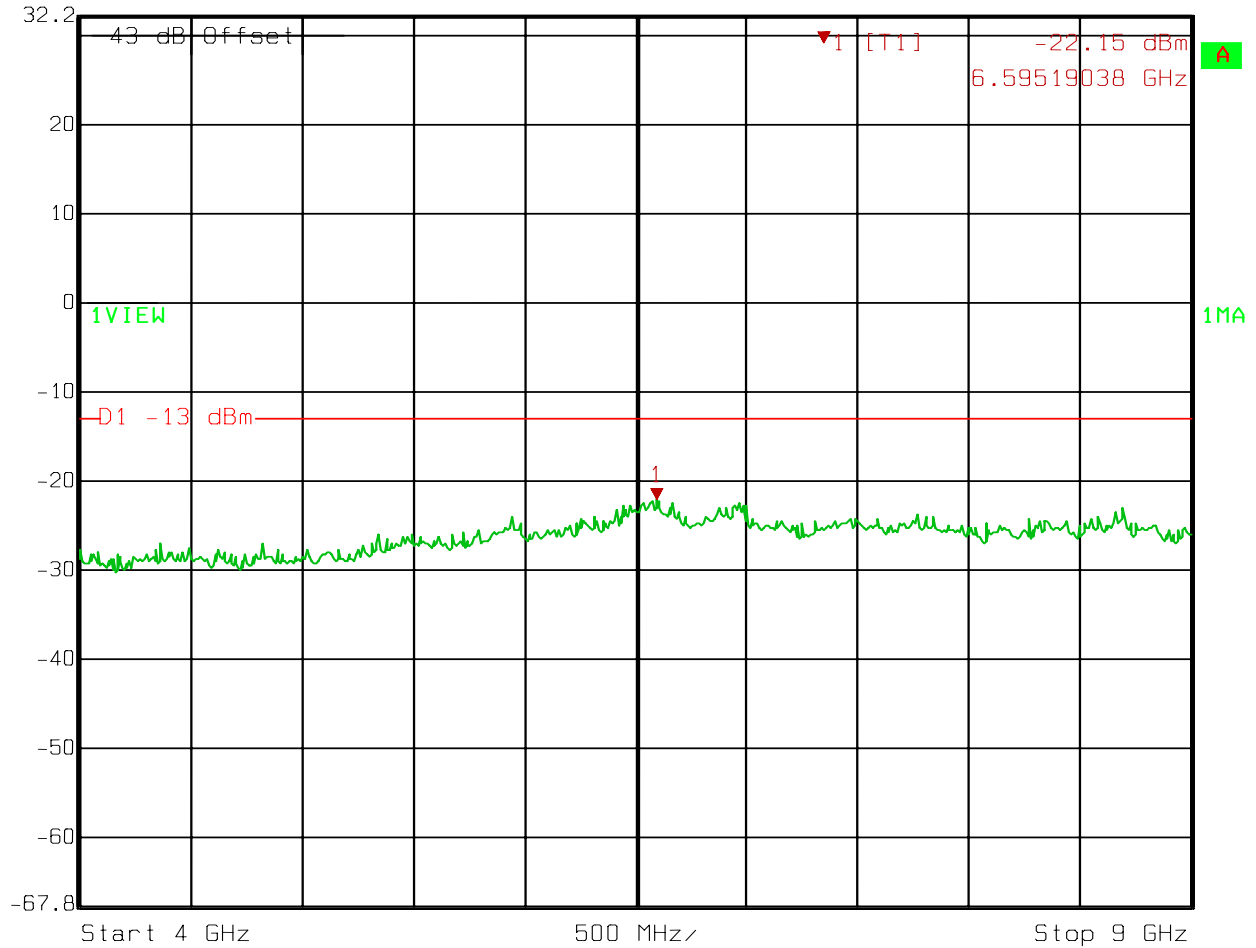

Date: 27.OCT.2005 09:30:46

The spectrum was investigated on three channels. The data presented is representative of all channels tested.

Section 6. Field Strength of Spurious

NAME OF TEST: Field Strength of Spurious	PARA. NO.: 2.1053
TESTED BY: David Light	DATE: 14 May 2004

Test Results: Complies.

Test Data: See attached table.

EQUIPMENT: DAC-850-125

Test Data – Field Strength of Spurious Emissions

<u>ERP Substitution Method</u>											
Page 1 of 1									Complete <u> x </u>		
Job No.:	4L0360			Date: 5/14/2004				Preliminary <u> </u>			
Specification:	PT22			Temperature(°C): <u> 20 </u>							
Tested By:	David Light			Relative Humidity(%) <u> 60 </u>							
E.U.T.:	DAC-850-125										
Configuration:	Tx full power into load										
Sample No:	1										
Location:	AC 3			RBW:	1 MHz			Measurement			
Detector Type:	Peak			VBW:	1 MHz			Distance:	<u> 3 </u> m		
Test Equipment Used											
Antenna:	1304			Directional Coupler:							
Pre-Amp:	1016			Cable #1:	1484						
Filter:				Cable #2:	1485						
Receiver:	1464			Cable #3:							
Attenuator #1				Cable #4:							
Attenuator #2:				Mixer:							
Additional equipment used:											
Measurement Uncertainty:	<u> +/-1.7 dB </u>										
Frequency (MHz)	Meter Reading (dBm)	Substitution Level (dBm)		Pre-Amp Gain (dB)	Substitution Antenna Gain (dBd)	ERP (dBm)	Limit (dBm)	Margin (dB)	Polarity	Comments	
1763	-32.0	-33.8		32.9	6.2	-27.6	-13.0	-14.5700	V		
2644.5	-26.0	-22.1		33	7.1	-15.0	-13.0	-1.9600	V		
3526	-48.7	-38.8		32.6	8.0	-30.9	-13.0	-17.8500	V		
4407.5	-69.3	-55.9		32.4	7.9	-48.0	-13.0	-35.0200	V		
5289	-73.0	-63.3		32.3	8.5	-54.8	-13.0	-41.7900	V		
6170.5	-74.6	-66.0		31.6	9.1	-56.9	-13.0	-43.8700	V		
7052	-73.0	-64.3		32.1	9.5	-54.9	-13.0	-41.8500	V		
7933.5	-72.0	-63.3		32.9	9.0	-54.3	-13.0	-41.3400	V		
8815	-73.0	-65.7		33.9	9.6	-56.2	-13.0	-43.1500	V		
1763	-34.2	-33.6		32.9	6.2	-27.4	-13.0	-14.3700	H		
2644.5	-25.6	-25.0		33	7.1	-17.9	-13.0	-4.8600	H		
3526	-46.2	-44.9		32.6	8.0	-37.0	-13.0	-23.9500	H		
4407.5	-66.5	-64.0		32.4	7.9	-56.1	-13.0	-43.1200	H		
5289	-73.0	-67.2		32.3	8.5	-58.7	-13.0	-45.6900	H		
6170.5	-74.6	-68.8		31.6	9.1	-59.7	-13.0	-46.6700	H		
7052	-73.0	-65.7		32.1	9.5	-56.3	-13.0	-43.2500	H		
7933.5	-72.0	-64.5		32.9	9.0	-55.5	-13.0	-42.5400	H		
8815	-73.0	-65.5		33.9	9.6	-56.0	-13.0	-42.9500	H		
Notes: _____											

Test Setup Photos

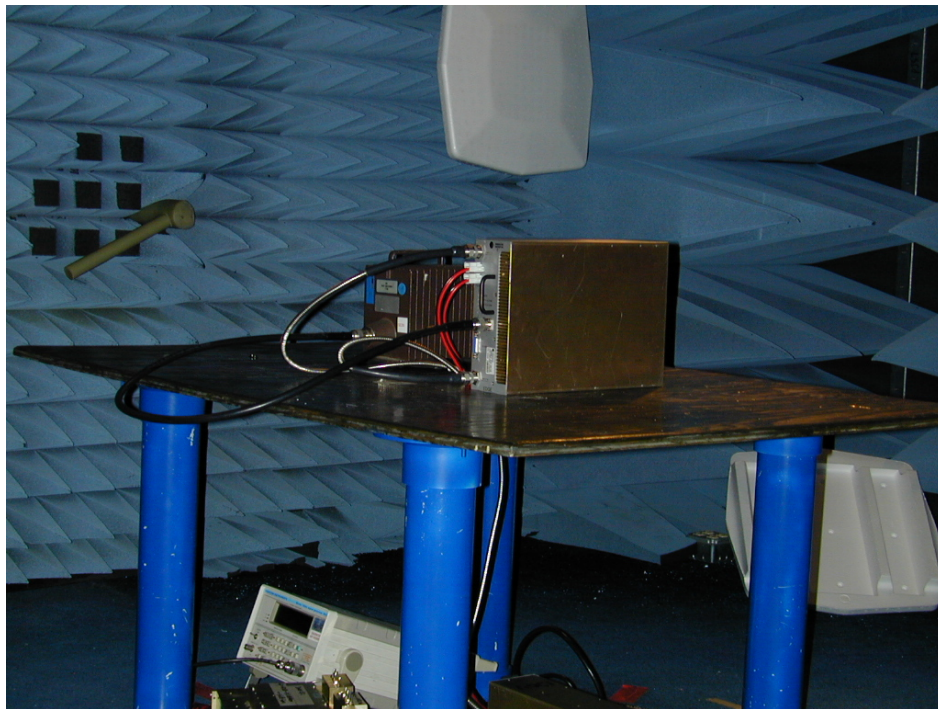
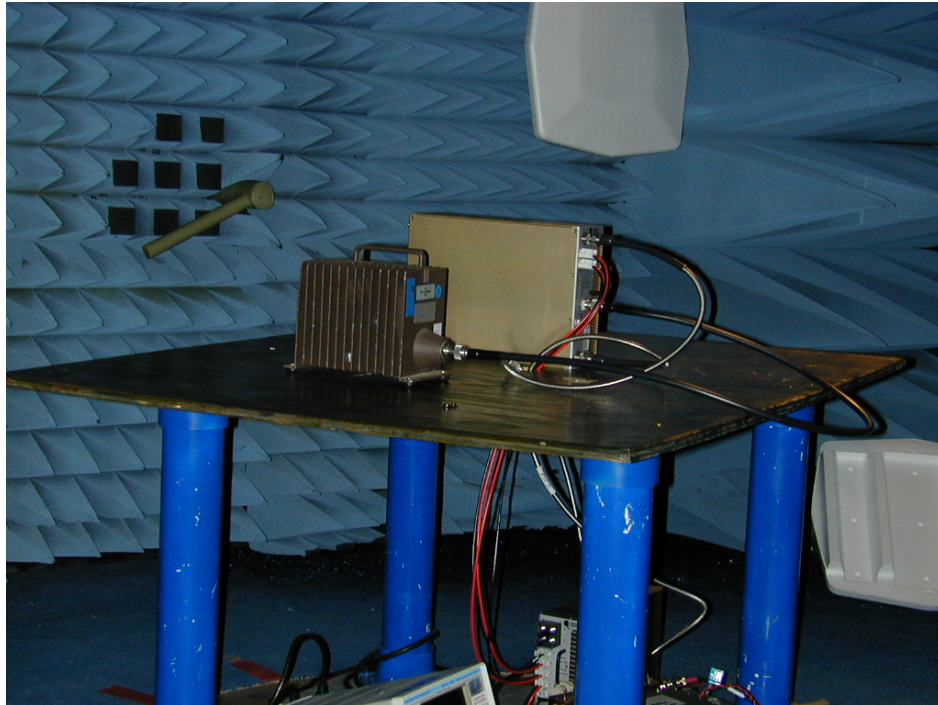

Section 7. Test Equipment List

Conducted Tests

Nemko ID	Description	Manufacturer Model Number	Serial Number	Calibration Date	Calibration Due
1036	SPECTRUM ANALYZER	ROHDE & SCHWARZ FSEK30	830844/006	03/22/04	03/23/06
1053	SIGNAL GENERATOR	ROHDE & SCHWARZ SMIQ 03	DE22081	06/10/03	06/11/06
1055	DUAL DIRECTIONAL COUPLER	NARDA 3022	73393	CBU	N/A
1054	DUAL DIRECTIONAL COUPLER	NARDA 3020A	34366	CBU	N/A
1058	DUAL DIRECTIONAL COUPLER	HEWLETT PACKARD 11692D	1212A03366	CBU	N/A
1064	ATTENUATOR	NARDA 776B-20	NONE	CBU	N/A
1067	Blue cable 4m	Storm PR90-010-144	0	CBU	N/A
1060	TUNABLE NOTCH FILTER	K&L 3TNF-500/1000-N/N	162	CBU	N/A

Radiated Tests

Nemko ID	Description	Manufacturer Model Number	Serial Number	Calibration Date	Calibration Due
1304	HORN ANTENNA	ELECTRO METRICS RGA-60	6151	09/22/03	09/22/05
1016	Pre-Amp	HEWLETT PACKARD 8449A	2749A00159	10/27/03	10/27/04
1464	Spectrum analyzer	Hewlett Packard 8563E	3551A04428	02/11/03	02/11/05
1484	Cable 2.0-18.0 Ghz	Storm PR90-010-072	N/A	07/24/03	07/24/04
1485	Cable 2.0-18.0 Ghz	Storm PR90-010-216	N/A	07/24/03	07/24/05

Nemko USA, Inc.

FCC PART 22, SUBPART H

850 MHz Cellular Band Amplifier

EQUIPMENT: DAC-850-125

Test Report No.: 52047RUS1

ANNEX A - TEST DETAILS

NAME OF TEST: RF Power Output	PARA. NO.: 2.1046
--------------------------------------	--------------------------

Minimum Standard: Para. No. 22.913(a). The maximum effective radiated power (ERP) of base transmitters and cellular repeaters must not exceed 500 watts.

Method of Measurement:

Detachable Antenna:

The peak power at antenna terminals is measured using an in-line peak power meter or a spectrum analyzer with sufficient bandwidth. Power output is measured with the maximum rated input level.

Integral Antenna:

TIA/EIA-603-1992, Section 2.2.12

The antenna substitution method was used to determine the equivalent radiated power at spurious frequencies. The spurious emissions were measured at a distance of 3 meters. The EUT was then replaced with a reference substitution antenna with a known gain referenced to a dipole. This antenna was fed with a signal at the spurious frequency. The level of the signal was adjusted to repeat the previously measured level. The resulting erp is the signal level fed to the reference antenna corrected for gain referenced to a dipole.

Nemko USA, Inc.

FCC PART 22, SUBPART H

850 MHz Cellular Band Amplifier

EQUIPMENT: DAC-850-125

Test Report No.: 52047RUS1

NAME OF TEST: Occupied Bandwidth

PARA. NO.: 2.1049

Minimum Standard: Not defined by FCC. Input vs. Output.

Method Of Measurement:

Spectrum Analyzer Settings:

RBW: 3 kHz

VBW: \geq RBW

Span: 1 MHz

Sweep: Auto

NAME OF TEST: Spurious Emission at Antenna Terminals	PARA. NO.: 2.1051
---	--------------------------

Minimum Standard:

Para. No. 22.917(a). Out of band emissions. The power of any emission outside of the authorized operating frequency ranges must be attenuated below the transmitting power (P) by a factor of at least $43 + 10 \log(P)$ dB. This is equivalent to -13 dBm absolute power.

Method Of Measurement:

Spectrum Analyzer Settings:

RBW: >100 kHz below 1000 MHz / 1 MHz above 1000 MHz

VBW: \geq RBW

Start Frequency: 30 MHz

Stop Frequency: 9 GHz

Sweep: Auto

NAME OF TEST: Field Strength of Spurious Radiation

PARA. NO.: 2.1053

Minimum Standard: Para. No. 22.917(a). Out of band emissions. The power of any emission outside of the authorized operating frequency ranges must be attenuated below the transmitting power (P) by a factor of at least $43 + 10 \log(P)$ dB. This is equivalent to -13 dBm absolute power.

Test Method:

TIA/EIA-603-1992, Section 2.2.12

The antenna substitution method was used to determine the equivalent radiated power at spurious frequencies. The spurious emissions were measured at a distance of 3 meters. The EUT was then replaced with a reference substitution antenna with a known gain referenced to a dipole. This antenna was fed with a signal at the spurious frequency. The level of the signal was adjusted to repeat the previously measured level. The resulting erp is the signal level fed to the reference antenna corrected for gain referenced to a dipole.

NAME OF TEST: Frequency Stability	PARA. NO.: 2.1055
--	--------------------------

Minimum Standard: Para. No. 22.355. The transmitter carrier frequency shall remain within the tolerances given in Table C-1.

Table C-1

Freq. Range (MHz)	Base, fixed	Mobile > 3 W	Mobile ≤ 3 W
821 to 896	1.5	2.5	2.5

Method Of Measurement:

Frequency Stability With Voltage Variation:

The E.U.T. is placed in an environmental chamber and allowed to stabilize at +20 degrees Celsius for at least 15 minutes. The frequency counter and signal generator are phase locked with the same 10 MHz reference frequency by connecting the 10 MHz ref. out of the counter to the 10 MHz ref, in of the signal generator. With the voltage input to the E.U.T. set to 85% S.T.V., the frequency is measured in 30 second intervals for a period of 5 minutes. This procedure is repeated at 100% S.T.V. and 115% S.T.V.

Frequency Stability With Temperature Variation:

The input voltage to the E.U.T. is set to S.T.V. and the temperature of the environmental chamber is varied in 10 degree steps from -30 degrees C to +50 degrees C. The E.U.T. is allowed to stabilize at each temperature and the frequency is measured in 30 second intervals for a period of 5 minutes.

Nemko USA, Inc.

FCC PART 22, SUBPART H

850 MHz Cellular Band Amplifier

EQUIPMENT: DAC-850-125

Test Report No.: 52047RUS1

ANNEX B - TEST DIAGRAMS

Para. No. 2.1046 - R.F. Power Output

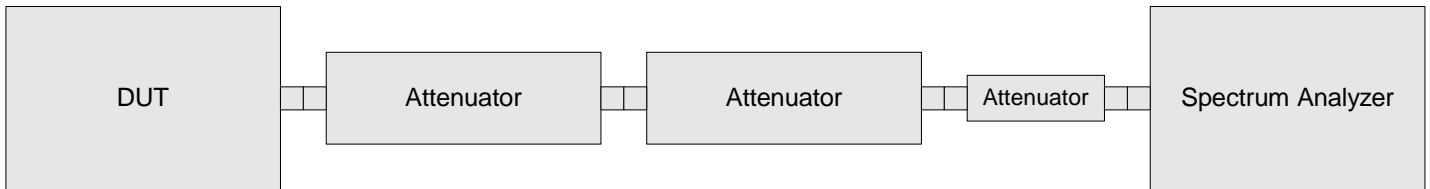

Para. No. 2.1049 - Occupied Bandwidth

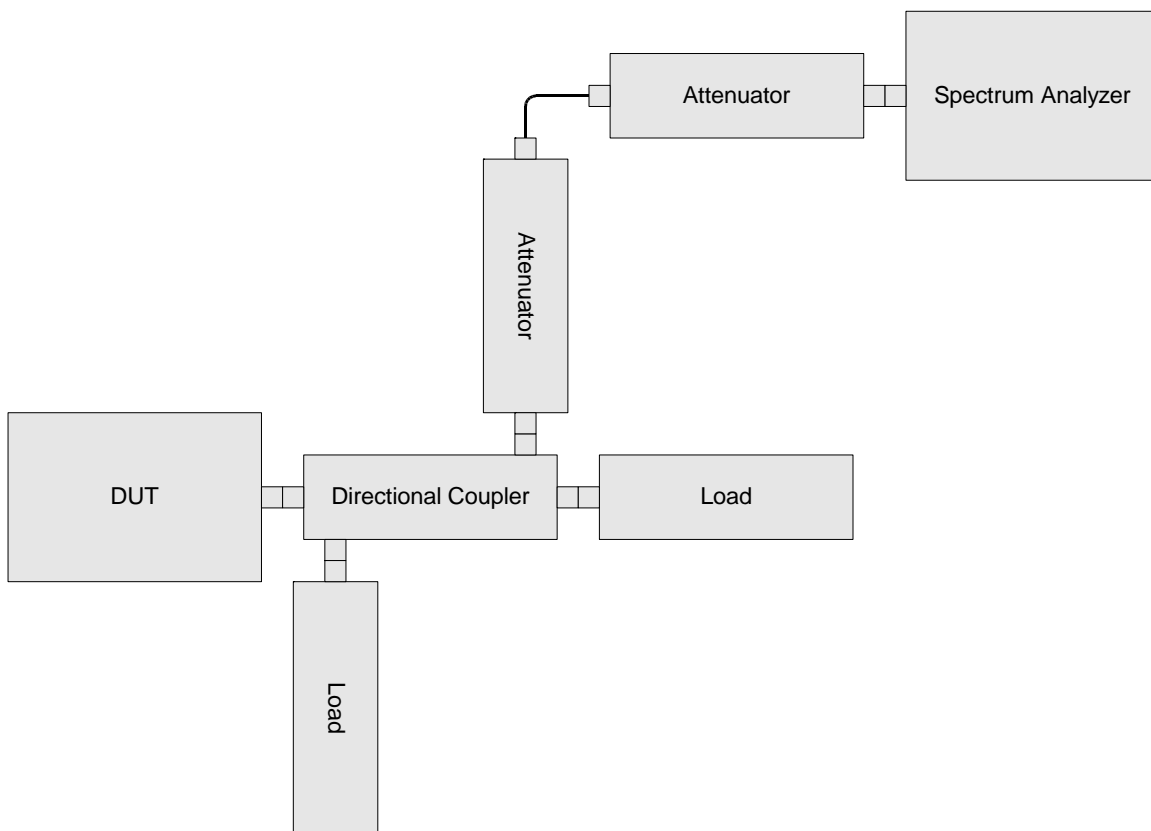

Para. No. 2.1051 Spurious Emissions at Antenna Terminals

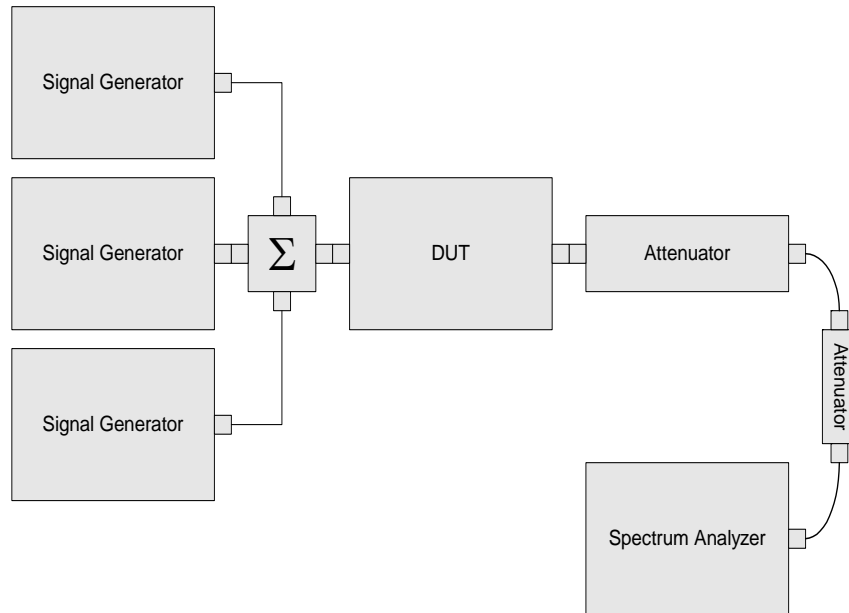

Para. No. 2.1053 - Field Strength of Spurious Radiation

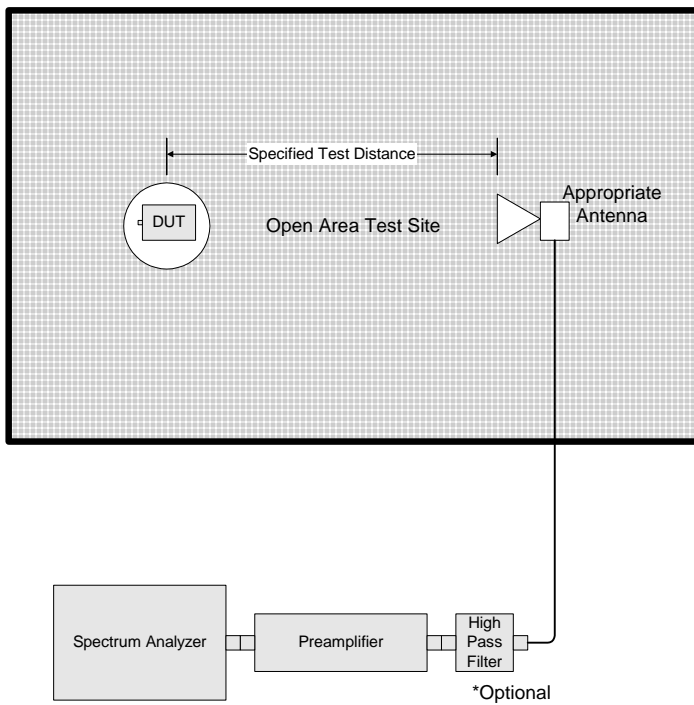
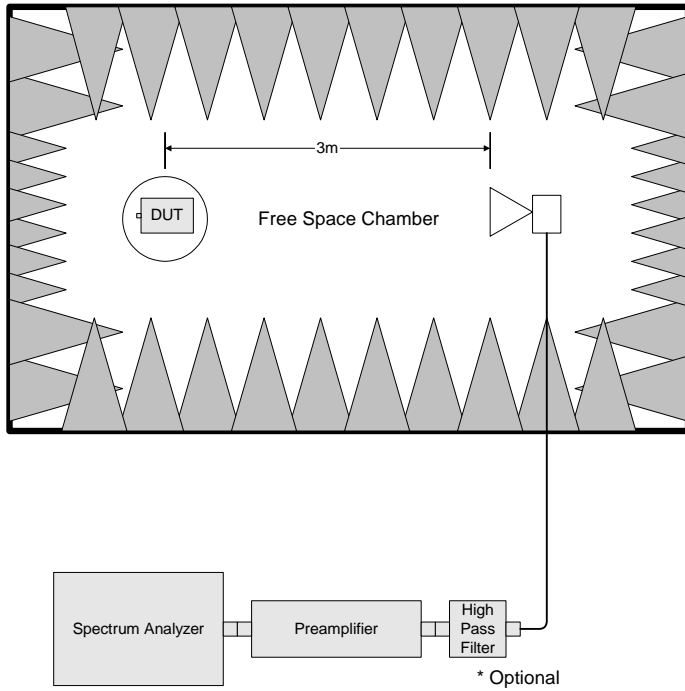

Para. No. 2.1055 - Frequency Stability

