

Test of WhereTrack WTK-5000

To: FCC 47 CFR Part 15.247 & IC RSS-210

Test Report Serial No.: ETSD15-A2 Rev A



TEST REPORT

FROM



Test of WhereTrack WTK-5000

to

FCC 47 CFR Part 15.247 & IC RSS-210

Test Report Serial No.: ETSD15-A2 Rev A

This report supersedes: None

Manufacturer: WhereNet
2858 De La Cruz Blvd.
Santa Clara
California 95050, USA

Product Function: RFID and Real Time Local
Positioning and Tracking

Copy No: pdf **Issue Date:** 6th February '09

This Test Report is Issued Under the Authority of:

MiCOM Labs, Inc.
440 Boulder Court, Suite 200
Pleasanton, CA 94566 USA
Phone: +1 (925) 462-0304
Fax: +1 (925) 462-0306
www.micomlabs.com



CERTIFICATE #2381.01

MiCOM Labs is an ISO 17025 Accredited Testing Laboratory



Title: WhereTrack WTK-5000
To: FCC 47 CFR Part 15.247 & IC RSS-210
Serial #: ETSD15-A2 Rev A
Issue Date: 6th February '09
Page: 3 of 97

This page has been left intentionally blank

This test report may be reproduced in full only. The document may only be updated by MiCOM Labs personnel. Any changes will be noted in the Document History section of the report.



TABLE OF CONTENTS

ACCREDITATION, LISTINGS & RECOGNITION	5
1. TEST RESULT CERTIFICATE	8
2. REFERENCES AND MEASUREMENT UNCERTAINTY	9
2.1. Normative References	9
2.2. Test and Uncertainty Procedures	9
3. PRODUCT DETAILS AND TEST CONFIGURATIONS	10
3.1. Technical Details	10
3.2. Scope of Test Program	11
3.3. Equipment Model(s) and Serial Number(s)	13
3.4. Antenna Details	13
3.5. Cabling and I/O Ports	13
3.6. Test Configurations.....	14
3.7. Equipment Modifications.....	14
3.8. Deviations from the Test Standard	15
3.9. Subcontracted Testing or Third Party Data	15
4. TEST SUMMARY	16
5. TEST RESULTS	18
5.1. Device Characteristics	18
5.1.1. <i>6 dB and 99 % Bandwidth</i>	18
5.1.2. <i>Peak Output Power</i>	27
5.1.3. <i>Peak Power Spectral Density</i>	36
5.1.4. <i>Maximum Permissible Exposure</i>	45
5.1.5. <i>Conducted Spurious Emissions</i>	46
5.1.6. <i>Radiated Emissions</i>	61
5.1.7. <i>AC Wireline Conducted Emissions (150 kHz – 30 MHz)</i>	90
6. PHOTOGRAPHS.....	92
6.1. Radiated Emissions \leq 1 GHz	92
6.2. Radiated Emissions \geq 1 GHz	93
6.3. General Measurement Test Set-Up.....	94
6.4. Measurement Instrumentation	95
7. TEST EQUIPMENT DETAILS.....	96

This test report may be reproduced in full only. The document may only be updated by MiCOM Labs personnel. Any changes will be noted in the Document History section of the report.



Title: WhereTrack WTK-5000
To: FCC 47 CFR Part 15.247 & IC RSS-210
Serial #: ETSD15-A2 Rev A
Issue Date: 6th February '09
Page: 5 of 97

ACCREDITATION, LISTINGS & RECOGNITION

ACCREDITATION

MiCOM Labs, Inc. an accredited laboratory complies with the international standard EN ISO/IEC 17025. The company is accredited by the American Association for Laboratory Accreditation (A2LA) www.a2la.org test laboratory number 2381.01. MiCOM Labs test schedule is available at the following URL; <http://www.a2la.org/scopepdf/2381-01.pdf>





**THE AMERICAN ASSOCIATION FOR
LABORATORY ACCREDITATION**

ACCREDITED LABORATORY

A2LA has accredited

MICOM LABS
Pleasanton, CA

for technical competence in the field of

Electrical Testing

This laboratory is accredited in accordance with the recognized International Standard ISO/IEC 17025:2005 *General Requirements for the Competence of Testing and Calibration Laboratories*. This accreditation demonstrates technical competence for a defined scope and the operation of a laboratory quality management system (refer to joint ISO-ILAC-IAF Communiqué dated 18 June 2005).



Presented this 26th day of February 2008.



President
For the Accreditation Council
Certificate Number 2381.01
Valid to November 30, 2009

For the tests or types of tests to which this accreditation applies,
please refer to the laboratory's Electrical Scope of Accreditation.

This test report may be reproduced in full only. The document may only be updated by MiCOM Labs personnel. Any changes will be noted in the Document History section of the report.



LISTINGS

MiCOM Labs test facilities are listed by the following organizations;

North America

United States of America

Federal Communications Commission (FCC) Listing #: 102167

Canada

Industry Canada (IC) Listing #: 4143A

Japan Registration

VCCI Membership Number: 2959

- Radiation 3 meter site; Registration No. R-2881
- Line Conducted, Registration Nos. C-3181 & T-1470
- Emissions; Registration Nos. C-3180 & T-1469

RECOGNITION

APEC MRA (Asia-Pacific Economic Community Mutual Recognition Agreement)

Conformity Assessment Body (CAB) – MiCOM Labs

Test data generated by MiCOM Labs is accepted in the following countries under the APEC MRA.

Country	Recognition Body	Phase	CAB Identification No.
Australia	Australian Communications and Media Authority (ACMA)	I	US0159
Hong Kong	Office of the Telecommunication Authority (OFTA)	I	
Korea	Ministry of Information and Communication Radio Research Laboratory (RRL)	I	
Singapore	Infocomm Development Authority (IDA)	I	
Taiwan	Directorate General of Telecommunications (DGT) Bureau of Standards, Metrology and Inspection (BSMI)	I	

This test report may be reproduced in full only. The document may only be updated by MiCOM Labs personnel. Any changes will be noted in the Document History section of the report.



Title: WhereTrack WTK-5000
To: FCC 47 CFR Part 15.247 & IC RSS-210
Serial #: ETSD15-A2 Rev A
Issue Date: 6th February '09
Page: 7 of 97

DOCUMENT HISTORY

Document History		
Revision	Date	Comments
Draft		
Rev A		

This test report may be reproduced in full only. The document may only be updated by MiCOM Labs personnel. Any changes will be noted in the Document History section of the report.



Title: WhereTrack WTK-5000
To: FCC 47 CFR Part 15.247 & IC RSS-210
Serial #: ETSD15-A2 Rev A
Issue Date: 6th February '09
Page: 8 of 97

1. TEST RESULT CERTIFICATE

Manufacturer: WhereNet 2858 De La Cruz Blvd. Santa Clara California 95050, USA	Tested By: MiCOM Labs, Inc. 440 Boulder Court Suite 200 Pleasanton California, 94566, USA
EUT: WhereTrack WTK-5000	Telephone: +1 925 462 0304
Model: WTK-5000	Fax: +1 925 462 0306
S/N: VB0420800P12	
Test Date(s): 29th to 30th January '09	Website: www.micomlabs.com

STANDARD(S)	TEST RESULTS
FCC 47 CFR Part 15.247 & IC RSS-210	EQUIPMENT COMPLIES

MiCOM Labs, Inc. tested the equipment mentioned in accordance with the requirements set forth in the above standards. Test results indicate that the equipment tested is capable of demonstrating compliance with the requirements as documented within this report.

Notes:

1. This document reports conditions under which testing was conducted and the results of testing performed.
2. Details of test methods used have been recorded and kept on file by the laboratory.
3. Test results apply only to the item(s) tested.

Approved & Released for MiCOM Labs, Inc. by:



CERTIFICATE #2381.01



Graeme Grieve
Quality Manager MiCOM Labs,

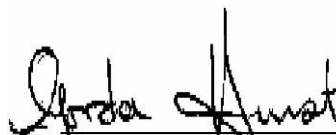

Gordon Hurst
President & CEO MiCOM Labs, Inc.

This test report may be reproduced in full only. The document may only be updated by MiCOM Labs personnel. Any changes will be noted in the Document History section of the report.

2. REFERENCES AND MEASUREMENT UNCERTAINTY

2.1. Normative References

Ref.	Publication	Year	Title
(i)	FCC 47 CFR Part 15.247	2007	Code of Federal Regulations
(ii)	Industry Canada RSS-210	Issue 7 June 2007	Low Power License-Exempt Radiocommunication Devices (All Frequency Bands)
(iii)	Industry Canada RSS-Gen	Issue 2 June 2007	General Requirements and Information for the Certification of Radiocommunication Equipment.
(iv)	ANSI C63.4	2003	American National Standards for Methods of Measurement of Radio-Noise Emissions from Low-Voltage Electrical and Electronic Equipment in the Range of 9 kHz to 40 GHz
(v)	CISPR 22/ EN 55022	1997 1998	Limits and Methods of Measurements of Radio Disturbance Characteristics of Information Technology Equipment
(vi)	M 3003	Edition 1 Dec. 1997	Expression of Uncertainty and Confidence in Measurements
(vii)	LAB34	Edition 1 Aug 2002	The expression of uncertainty in EMC Testing
(viii)	ETSI TR 100 028	2001	Parts 1 and 2 Electromagnetic compatibility and Radio Spectrum Matters (ERM); Uncertainties in the measurement of mobile radio equipment characteristics
(ix)	A2LA	14 th September '05	Reference to A2LA Accreditation Status – A2LA Advertising Policy

2.2. Test and Uncertainty Procedures

Conducted and radiated emission measurements were conducted in accordance with American National Standards Institute ANSI C63.4, listed in the Normative References section of this report.

Measurement uncertainty figures are calculated in accordance with ETSI TR 100 028 Parts 1 and 2.

Measurement uncertainties stated are based on a standard uncertainty multiplied by a coverage factor $k = 2$, providing a level of confidence of approximately 95 % in accordance with UKAS document M 3003 listed in the Normative References section of this report.



Title: WhereTrack WTK-5000
To: FCC 47 CFR Part 15.247 & IC RSS-210
Serial #: ETSD15-A2 Rev A
Issue Date: 6th February '09
Page: 10 of 97

3. PRODUCT DETAILS AND TEST CONFIGURATIONS

3.1. Technical Details

Details	Description
Purpose:	Test of the WhereTrack WTK-5000 to FCC Part 15.247 and Industry Canada RSS-210 regulations
Applicant:	As Manufacturer
Manufacturer:	WhereNet 2858 De La Cruz Blvd. Santa Clara California 95050, USA
Laboratory performing the tests:	MiCOM Labs, Inc. 440 Boulder Court, Suite 200 Pleasanton, California 94566 USA
Test report reference number:	ETSD15-A2 Rev A
Date EUT received:	29th January 2009
Standard(s) applied:	FCC 47 CFR Part 15.247 & IC RSS-210
Dates of test (from - to):	29th to 30th January '09
No of Units Tested:	1
Type of Equipment:	RFID and Real Time Local Positioning and Tracking Tag
Manufacturers Trade Name:	WhereTrack
Model:	WTK-5000
Location for use:	Indoor/Outdoor use
Declared Frequency Range(s):	2400 - 2483.5 MHz,
Type of Modulation:	Per 802.11b/g –CCK, BPSK, QPSK, OFDM
Declared Nominal Output Power:	802.11b/g: +17 dBm WhereNet DSSS: +20 dBm
EUT Modes of Operation:	802.11b/g, WhereNet DSSS Mode 2441.75 MHz
Transmit/Receive Operation:	Time Division Duplex
Rated Input Voltage and Current:	12 Vdc, 1 A
Operating Temperature Range:	Declared range -40 to +60°C
ITU Emission Designator:	802.11b – 15M6W7D 802.11g – 16M8W7D DSSS – 48M1W7D
Microprocessor(s) Model:	Integrated LEON SPARC
Clock/Oscillator(s):	10.1737 MHz
Frequency Stability:	±20 ppm
Equipment Dimensions:	18.24"x 11.00"x 14.21"
Weight:	4lbs 14ozs / 2.21 kg
Primary function of equipment:	RFID and real time local positioning and tracking device

This test report may be reproduced in full only. The document may only be updated by MiCOM Labs personnel. Any changes will be noted in the Document History section of the report.

3.2. Scope of Test Program

The scope of the test program was to test the WhereTrack WTK-5000 RFID and Real Time Local Positioning and Tracking device for compliance against FCC 47 CFR Part 15.247 and Industry Canada RSS-210 specifications.

The WTK-5000 RFID Real Time Local Positioning and Tracking device has two radios which do not operate simultaneously;

802.11 b/g and DSSS: 2441.75 MHz

GPS Receiver (1588.5 MHz/1236 MHz)

The WhereTrack was originally tested and certified in 2007. The 802.11b/g WiFi device was made obsolete and therefore this test program only exercises the 802.11b/g device. Results for the DSSS and GPS receiver were reused.

WhereNet WTK-5000 802.11 b/g Real Time Locating System



This test report may be reproduced in full only. The document may only be updated by MiCOM Labs personnel. Any changes will be noted in the Document History section of the report.

**WhereNet WTK-5000
802.11 b/g Real Time Locating System**

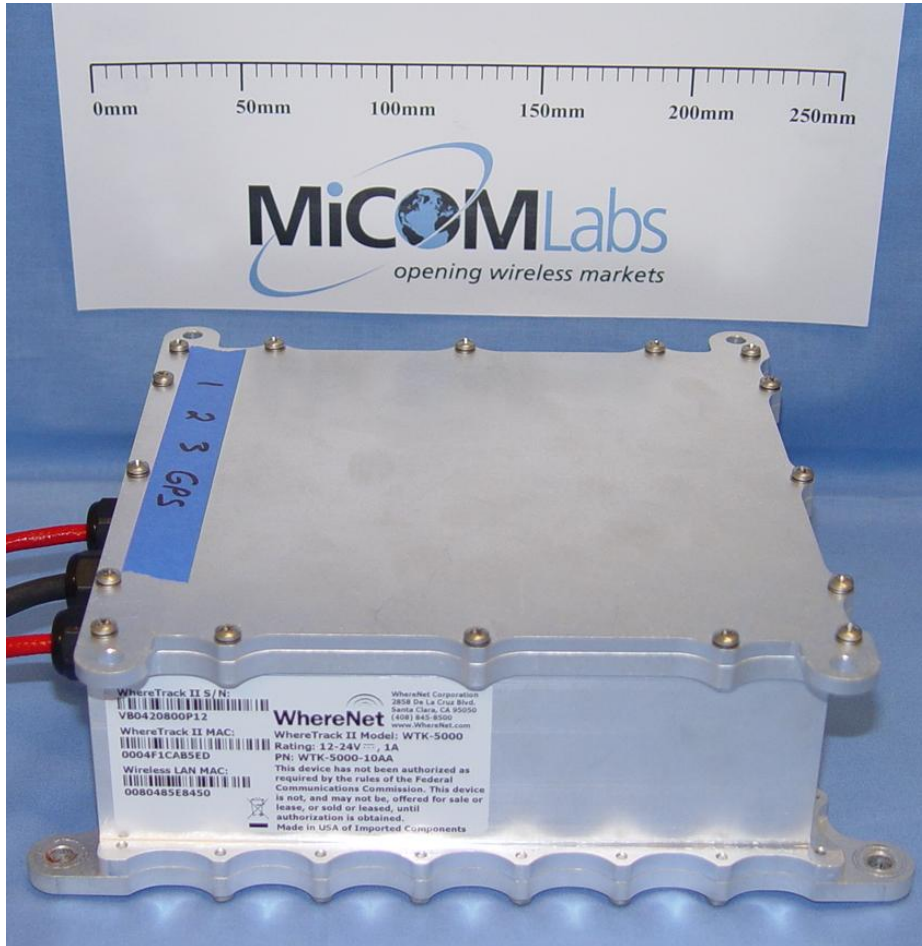

This test report may be reproduced in full only. The document may only be updated by MiCOM Labs personnel. Any changes will be noted in the Document History section of the report.



Title: WhereTrack WTK-5000
To: FCC 47 CFR Part 15.247 & IC RSS-210
Serial #: ETSD15-A2 Rev A
Issue Date: 6th February '09
Page: 13 of 97

3.3. Equipment Model(s) and Serial Number(s)

Type (EUT/Support)	Equipment Description (Including Brand Name)	Mfr	Model No.	Serial No.
EUT	WhereTrack RFID and real time local positioning and tracking device	WhereNet	WTK-5000	VB0420800P12
Support	Antenna Kit	WhereNet	AK-700-00	None
Support	Cisco Access Point	Cisco	AP1242AG-E-K9	FOC112968Z8
Support	Laptop	Dell	--	--

3.4. Antenna Details

Antenna Type	Gain (dBi)	Manufacturer	Model No.	Serial No.
Whip (Dipole)	+5	Larsen	NM05E2400B	--
GPS Receiver 3.5" Diameter Active L1 GPS Antenna	--	Antcom Corp	GPS/ANT-536/536-C	--

3.5. Cabling and I/O Ports

Number and type of I/O ports

1. DC Power
2. RS 232
3. RS 433
4. 10/100BT

This test report may be reproduced in full only. The document may only be updated by MiCOM Labs personnel. Any changes will be noted in the Document History section of the report.

3.6. Test Configurations

Matrix of test configurations

Operational Mode	Frequencies (MHz)
802.11b/g	2,412
	2,437
	2,462
DSSS	2441.75

The WhereTrack did not have access to test software. As a result the WhereTrack associated with an access point during the test program.

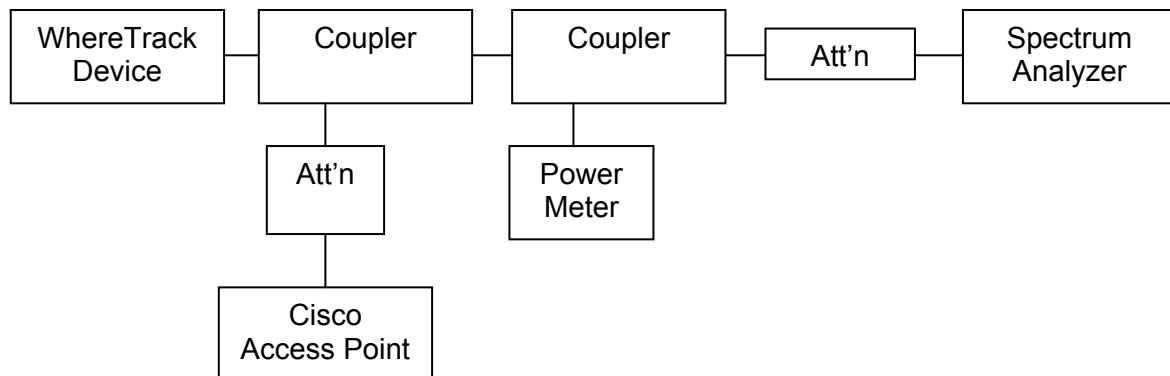

Test Setup – Conducted & Radiated

3.7. Equipment Modifications

The following modifications were required to bring the equipment into compliance:

1. None



Title: WhereTrack WTK-5000
To: FCC 47 CFR Part 15.247 & IC RSS-210
Serial #: ETSD15-A2 Rev A
Issue Date: 6th February '09
Page: 15 of 97

3.8. Deviations from the Test Standard

The following deviations from the test standard were required in order to complete the test program:

1. NONE

3.9. Subcontracted Testing or Third Party Data

1. NONE

This test report may be reproduced in full only. The document may only be updated by MiCOM Labs personnel. Any changes will be noted in the Document History section of the report.



4. TEST SUMMARY

List of Measurements

The following table represents the list of measurements required under the **FCC CFR47 Part 15.247** and **Industry Canada RSS-210** and **Industry Canada RSS-Gen**.

Section(s)	Test Items	Description	Condition	Result	Test Report Section
15.247(a)(2) A8.2(1) 4.4	6 dB and 99 % Bandwidths	≥ 500 kHz	Conducted	Complies	5.1.1
15.247(b)(3) 15.31(e) A8.4(4)	Peak Output Power Voltage Variation	Shall not exceed 1W Variation of supply voltage 85 % -115 %	Conducted	Complies	5.1.2
15.247(e) A8.2	Peak Power Spectral Density	Shall not be greater than +8 dBm in any 3 kHz band	Conducted	Complies	5.1.3
15.247(i) 5.5	Maximum Permissible Exposure	Exposure to radio frequency energy levels	Conducted	Complies	5.1.4
15.247(d) 15.205 / 15.209 A8.5 2.2 4.7	Spurious Emissions (30MHz - 26 GHz)	The radiated emission in any 100 kHz of out-band shall be at least 20 dB below the highest in-band spectral density	Conducted	Complies	5.1.5

This test report may be reproduced in full only. The document may only be updated by MiCOM Labs personnel. Any changes will be noted in the Document History section of the report.



List of Measurements (continued)

The following table represents the list of measurements required under the **FCC CFR47 Part 15.247**, **Industry Canada RSS-210**, and **Industry Canada RSS-Gen**.

Section(s)	Test Items	Description	Condition	Result	Test Report Section
15.247(d) 15.205 / 15.209 A8.5 2.2 2.6 4.7	Radiated Emissions	Restricted Bands	Radiated	Complies	5.1.6
	Transmitter Radiated Spurious Emissions, Peak Emissions, Band Edge	Emissions above 1 GHz		Complies	5.1.6.1
Industry Canada only RSS-Gen §4.8, §6	Receiver Radiated Spurious Emissions	Emissions above 1 GHz		Complies	5.1.6.2
15.205 / 15.209 2.2	Radiated Spurious Emissions	Emissions <1 GHz (30M-1 GHz)	Radiated	Complies Class A	5.1.6.3
15.207 7.2.2	AC Wireline Conducted Emissions 150 kHz– 30 MHz	Conducted Emissions	Conducted	Not Applicable Device dc powered	5.1.7

Note 1: Test results reported in this document relate only to the items tested

Note 2: The required tests demonstrated compliance as per client declaration of test configuration, monitoring methodology and associated pass/fail criteria

Note 3: Section - Equipment Modifications highlights the equipment modifications that were required to bring the product into compliance with the above test matrix

5. TEST RESULTS

5.1. Device Characteristics

5.1.1. 6 dB and 99 % Bandwidth

FCC, Part 15 Subpart C §15.247(a)(2)

Industry Canada RSS-210 §A8.2

Industry Canada RSS-Gen §4.4

Test Procedure

The bandwidth at 6 dB and 99 % is measured with a spectrum analyzer connected to the antenna terminal, while EUT is operating in transmission mode at the appropriate center frequency.

Test Measurement Set up

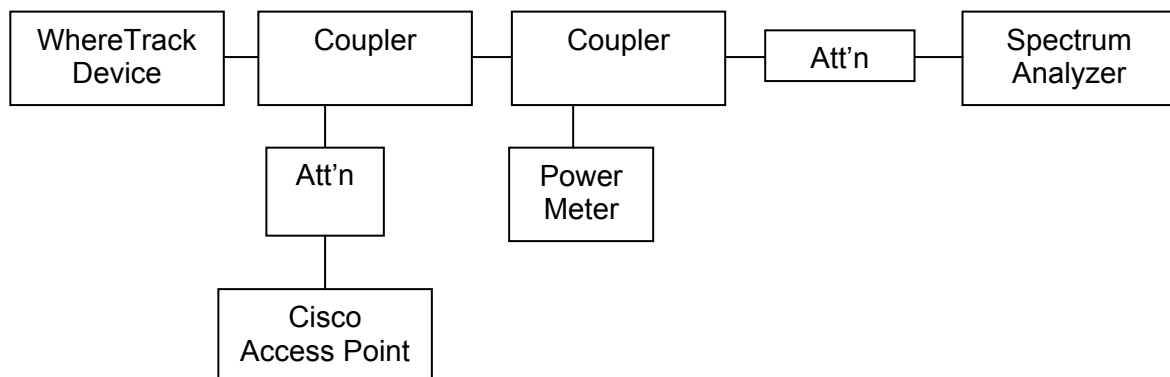

Measurement set up for 6 dB and 99 % bandwidth test



Measurement Results for 6 dB and 99 % Operational Bandwidth(s)

Ambient conditions.

Temperature: 17 to 23 °C Relative humidity: 31 to 57 % Pressure: 999 to 1012 mbar

TABLE OF RESULTS – 802.11b

Center Frequency (MHz)	6 dB Bandwidth (MHz)	99 % BW (MHz)
2,412	12.525	15.631
2,437	11.122	15.531
2,462	12.024	15.531

2412 MHz 6 dB and 99% Bandwidth

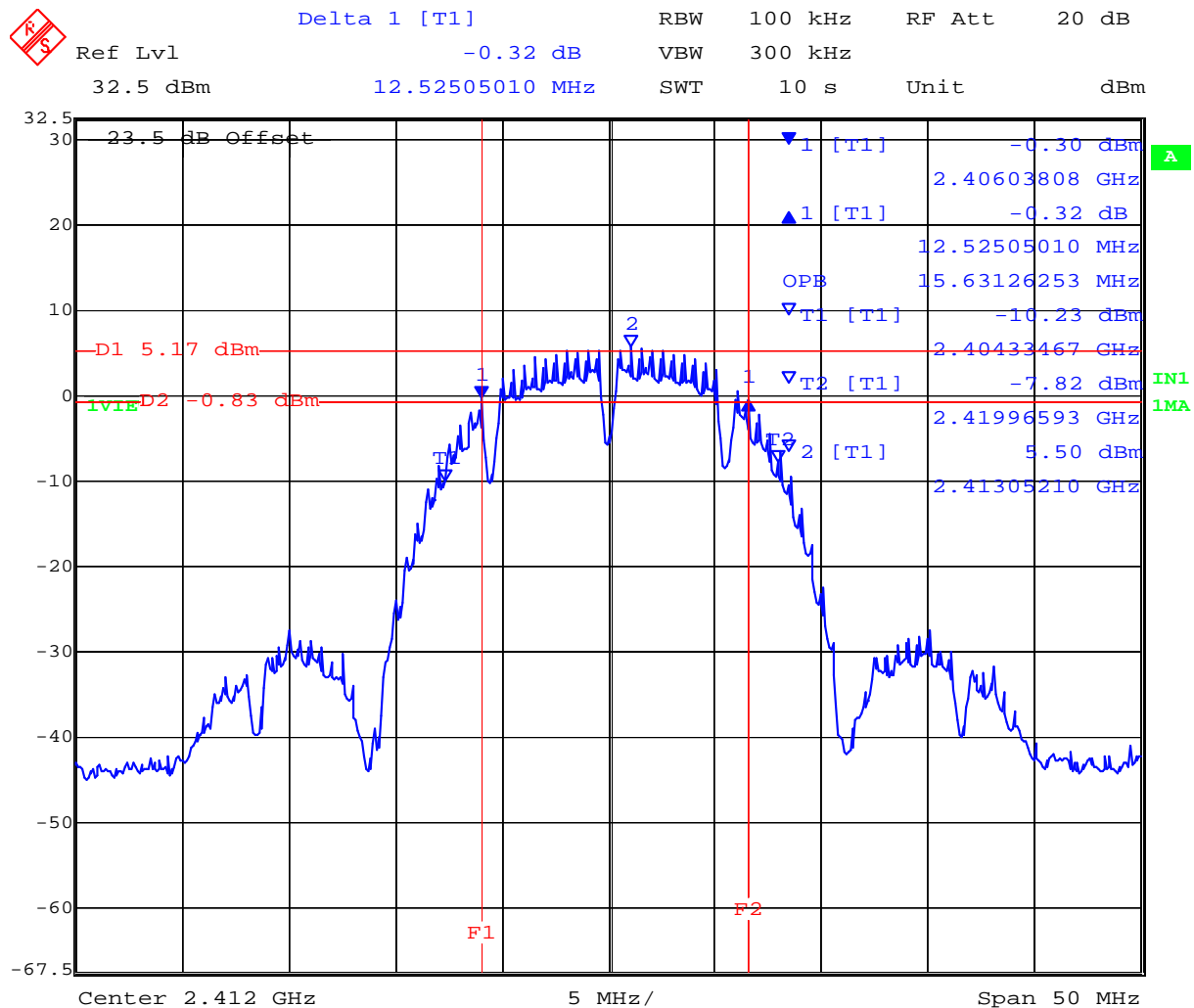

Date: 29.JAN.2009 09:44:02

This test report may be reproduced in full only. The document may only be updated by MiCOM Labs personnel. Any changes will be noted in the Document History section of the report.



2437 MHz 6 dB and 99% Bandwidth

K/S
 Delta 1 [T1] RBW 100 kHz RF Att 20 dB
 Ref Lvl -1.29 dB VBW 300 kHz
 32.5 dBm 11.12224449 MHz SWT 10 s Unit dBm

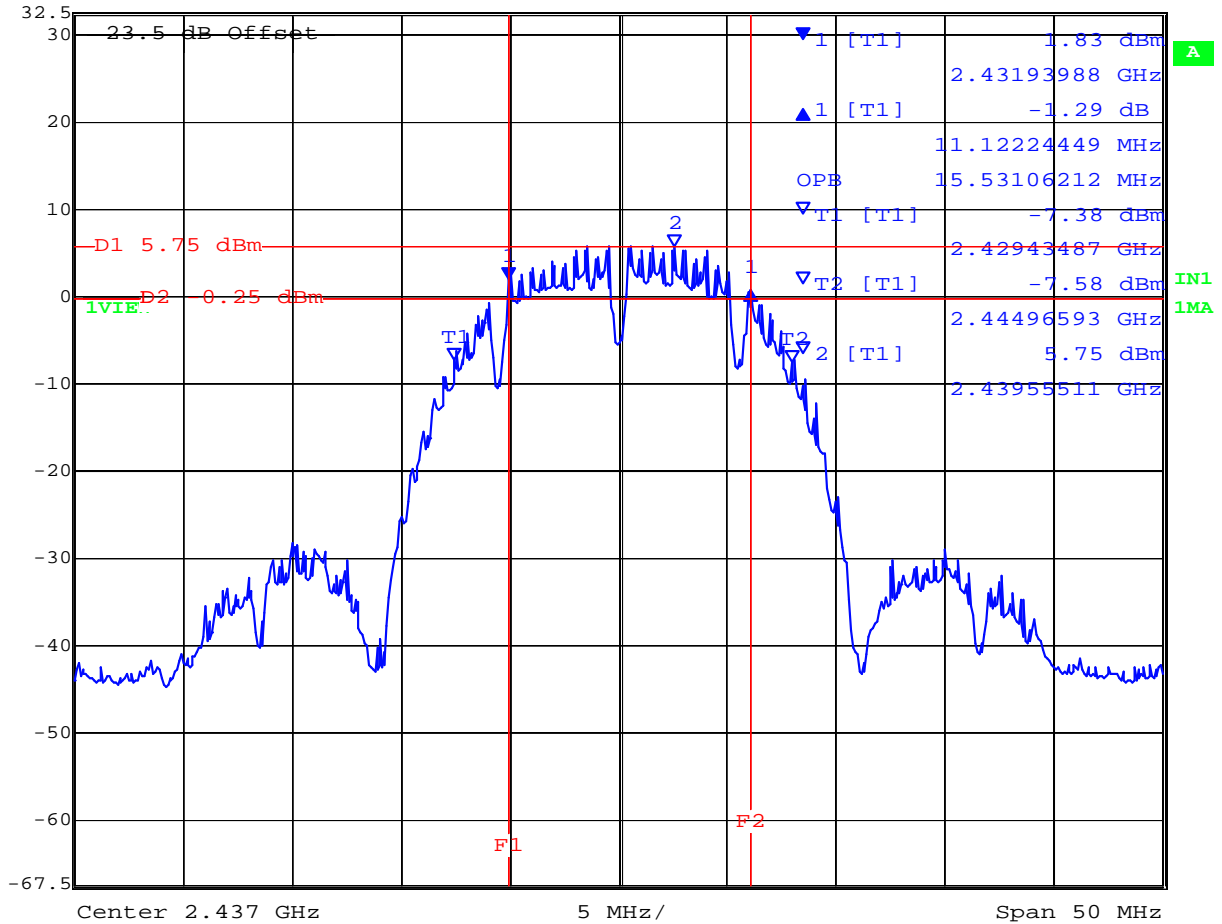

Date: 29.JAN.2009 09:46:37

This test report may be reproduced in full only. The document may only be updated by MiCOM Labs personnel. Any changes will be noted in the Document History section of the report.



2462 MHz 6 dB and 99% Bandwidth

Delta 1 [T1] RBW 100 kHz RF Att 20 dB
 Ref Lvl -0.13 dB VBW 300 kHz
 32.5 dBm 12.02404810 MHz SWT 10 s Unit dBm

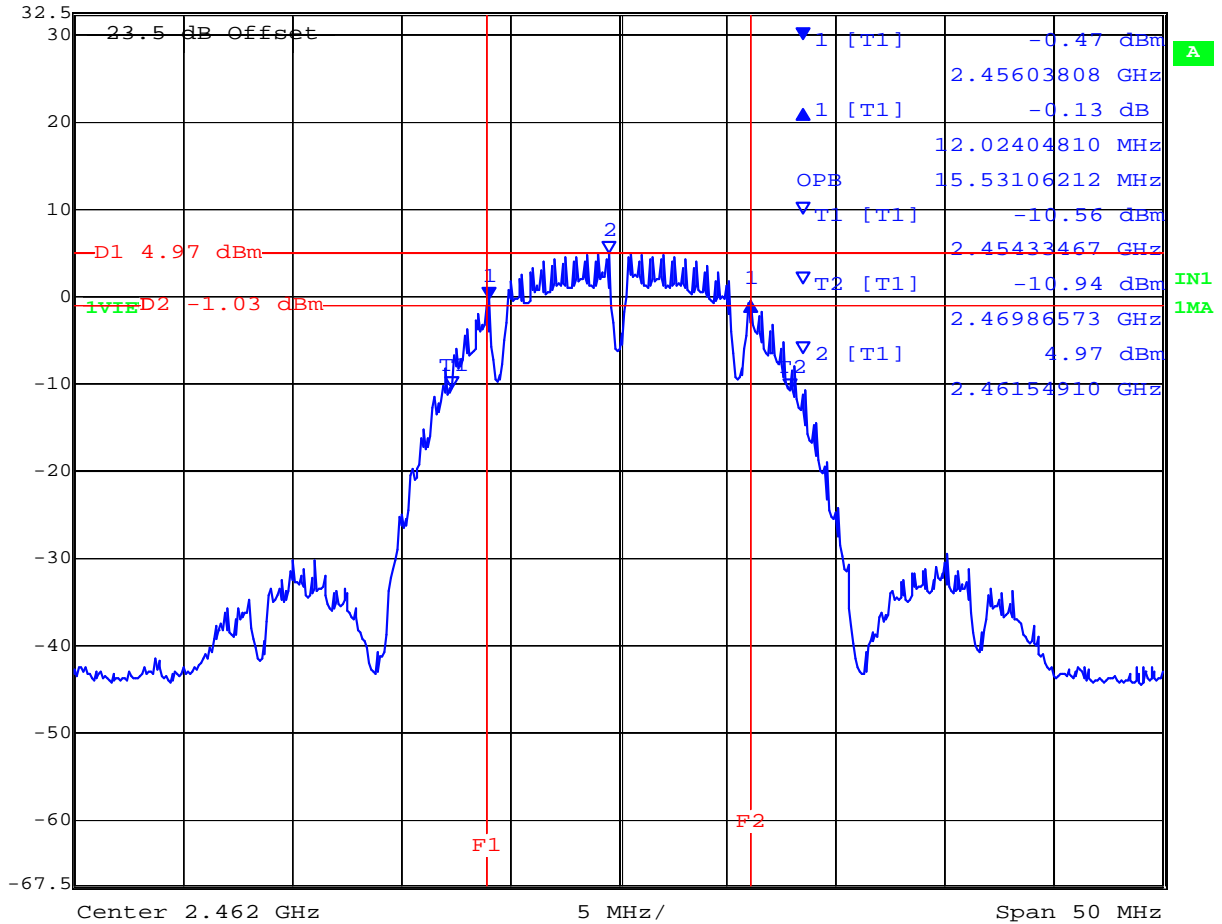

Date: 29.JAN.2009 09:52:05

This test report may be reproduced in full only. The document may only be updated by MiCOM Labs personnel. Any changes will be noted in the Document History section of the report.



TABLE OF RESULTS – 802.11g

Center Frequency (MHz)	6 dB Bandwidth (MHz)	99 % BW (MHz)
2,412	16.333	16.733
2,437	16.433	16.834
2,462	16.533	16.633

2412 MHz 6 dB and 99% Bandwidth

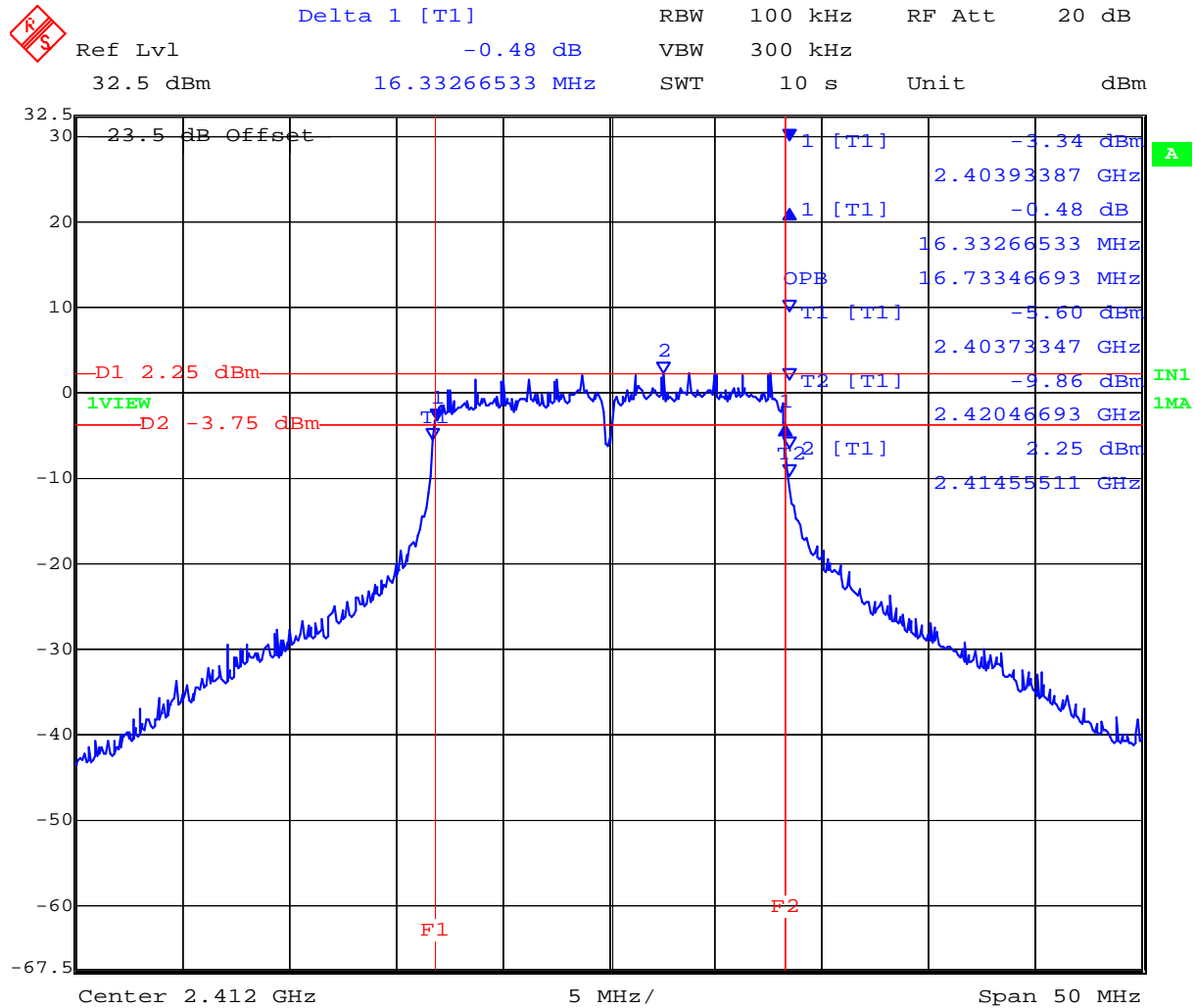

Date: 29.JAN.2009 10:06:51

This test report may be reproduced in full only. The document may only be updated by MiCOM Labs personnel. Any changes will be noted in the Document History section of the report.



2437 MHz 6 dB and 99% Bandwidth

Delta 1 [T1] RBW 100 kHz RF Att 20 dB
 Ref Lvl -0.55 dB VBW 300 kHz
 32.5 dBm 16.43286573 MHz SWT 10 s Unit dBm

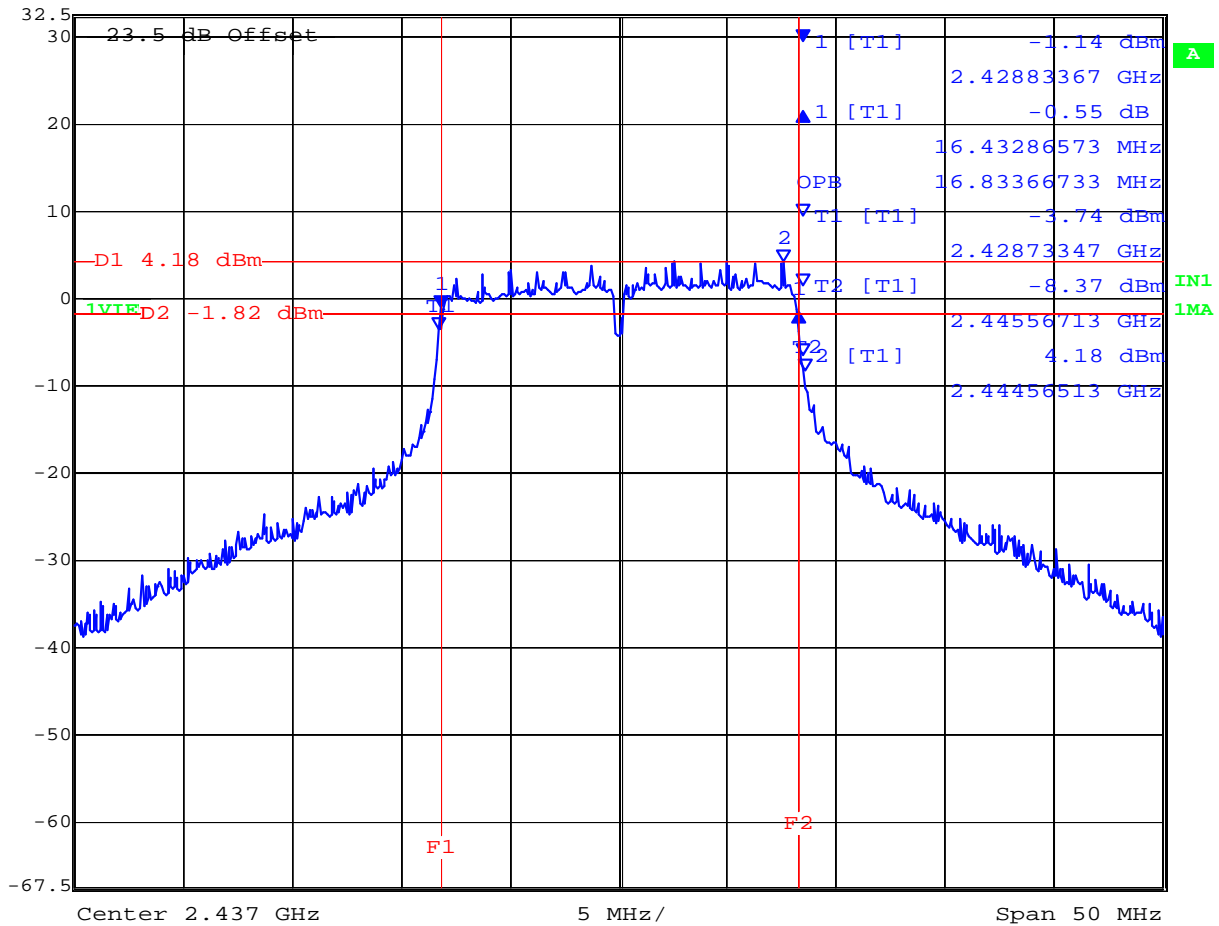

Date: 29.JAN.2009 10:03:15

This test report may be reproduced in full only. The document may only be updated by MiCOM Labs personnel. Any changes will be noted in the Document History section of the report.



2462 MHz 6 dB and 99% Bandwidth

K/S
 Delta 1 [T1] RBW 100 kHz RF Att 20 dB
 Ref Lvl -0.05 dB VBW 300 kHz
 32.5 dBm 16.53306613 MHz SWT 10 s Unit dBm

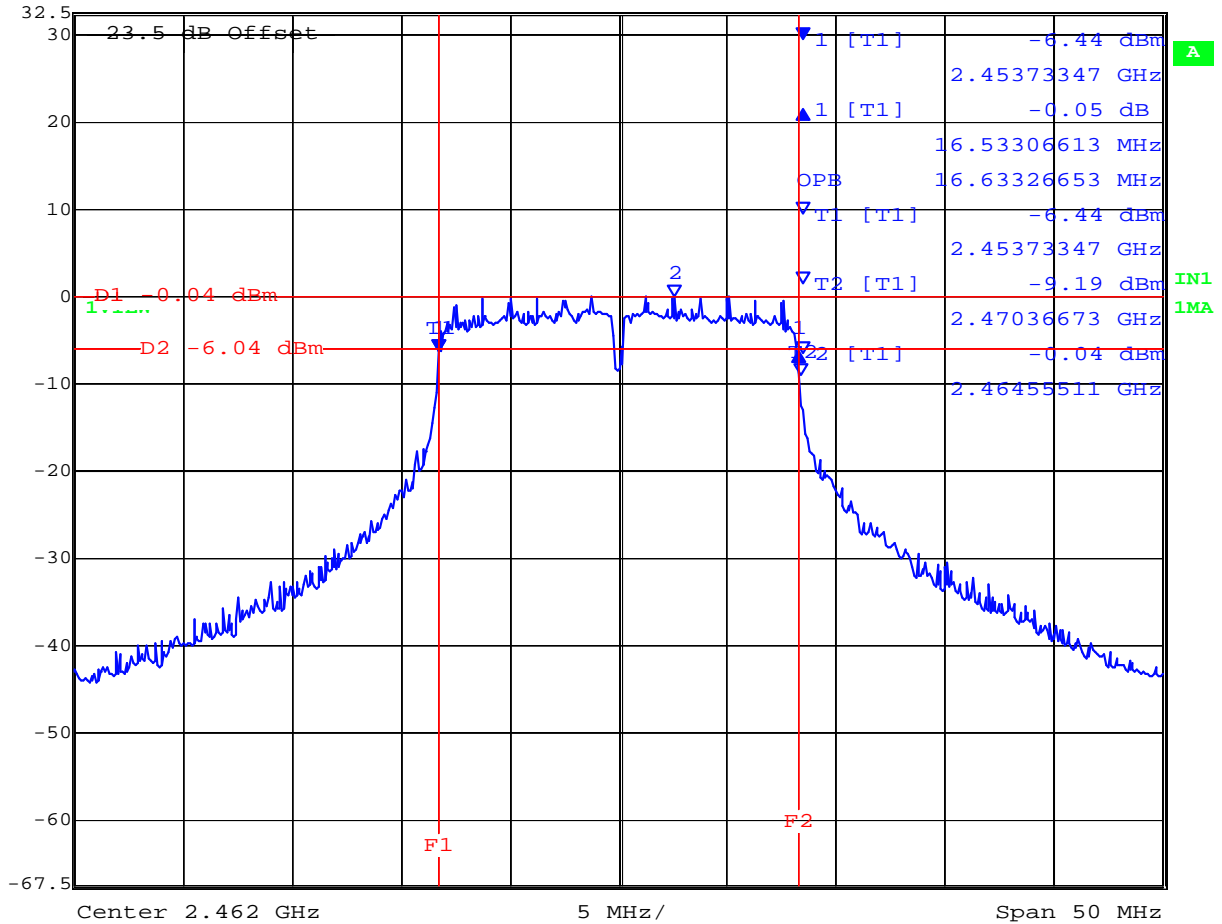

Date: 29.JAN.2009 09:54:59

This test report may be reproduced in full only. The document may only be updated by MiCOM Labs personnel. Any changes will be noted in the Document History section of the report.

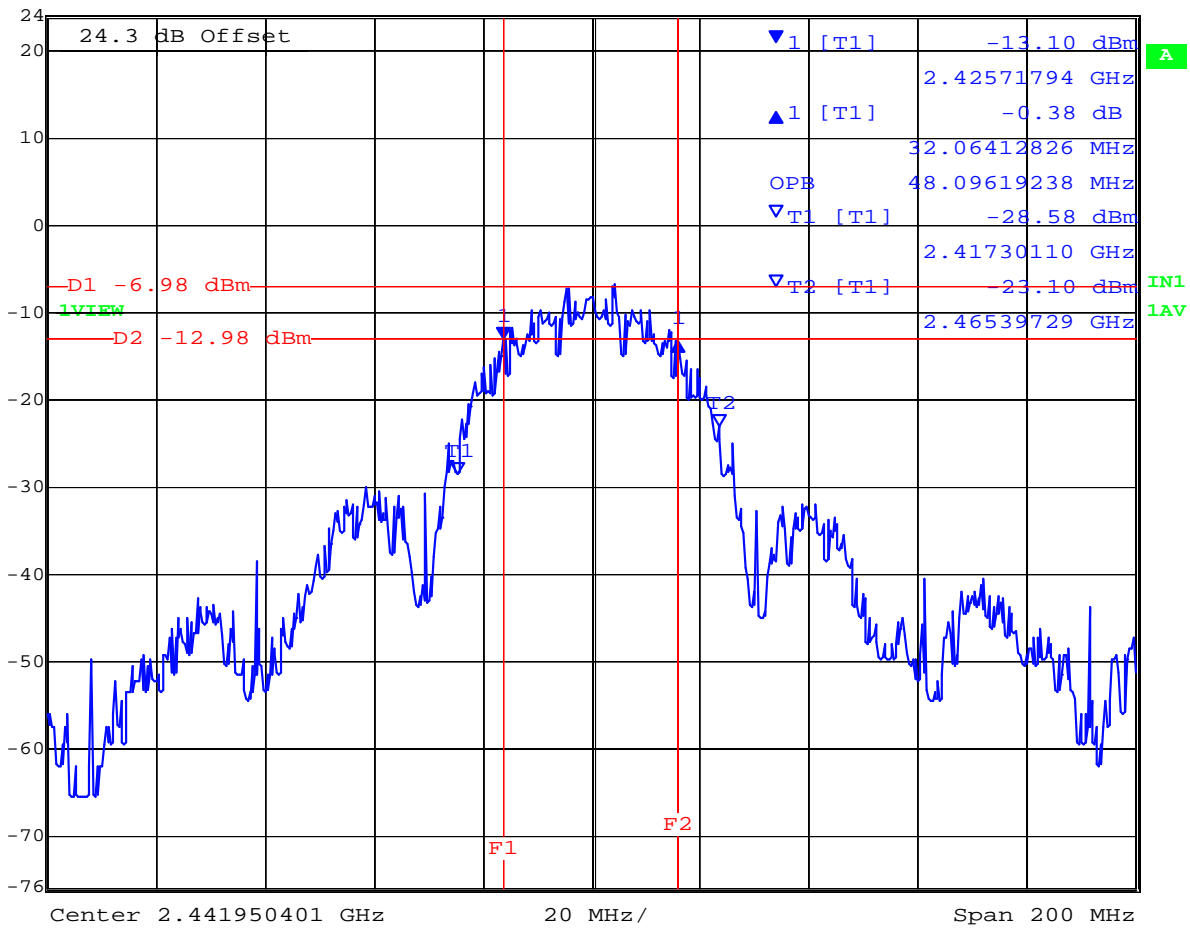

TABLE OF RESULTS – DSSS

Center Frequency (MHz)	6 dB Bandwidth (MHz)	99 % BW (MHz)
2441.75	32.06412826	48.09619238

DSSS 2441.75 MHz 6 dB and 99% Bandwidth

Delta 1 [T1] RBW 100 kHz RF Att 10 dB
 Ref Lvl -0.38 dB VBW 300 kHz
 24 dBm 32.06412826 MHz SWT 500 ms Unit dBm



Date: 5.SEP.2007 17:38:32

This test report may be reproduced in full only. The document may only be updated by MiCOM Labs personnel. Any changes will be noted in the Document History section of the report.



Specification

Limits

§15.247 (a)(2) & RSS-210 §A8.2(1)

The minimum 6 dB bandwidth shall be at least 500 kHz.

§ IC RSS-Gen 4.4.1 Occupied Bandwidth When an occupied bandwidth value is not specified in the applicable RSS, the transmitted signal bandwidth to be reported is to be its 99% emission bandwidth, as calculated or measured.

§ IC RSS-Gen 4.4.2 6 dB Bandwidth Where indicated, the 6 dB bandwidth is measured at the points when the spectral density of the signal is 6 dB down from the in-band spectral density of the modulated signal, with the transmitter modulated by a representative signal.

Laboratory Measurement Uncertainty for Spectrum Measurement

Measurement uncertainty	±2.81 dB
-------------------------	----------

Traceability

Method	Test Equipment Used
Measurements were made per work instruction WI-03 'Measurement of RF Spectrum Mask'	0158, 0193, 0252, 0313, 0314, 0070, 0116, 0117

This test report may be reproduced in full only. The document may only be updated by MiCOM Labs personnel. Any changes will be noted in the Document History section of the report.

5.1.2. Peak Output Power

FCC, Part 15 Subpart C §15.247(b)(3), §15.31(e)
Industry Canada RSS-210 §A8.4(4)

Test Procedure

The transmitter terminal of EUT was connected to the input of the spectrum analyzer set to measure peak power. The resolution filter bandwidth was set to 6 dB, peak detector selected and the analyzer built-in power function was used to measure peak power over the 99 % bandwidth. Initial measurements were employed to define which data rate provided the highest output power. Measurements were made while EUT was operating in a continuous transmission mode i.e. 100 % duty cycle at the appropriate center frequency.

Test Measurement Set up

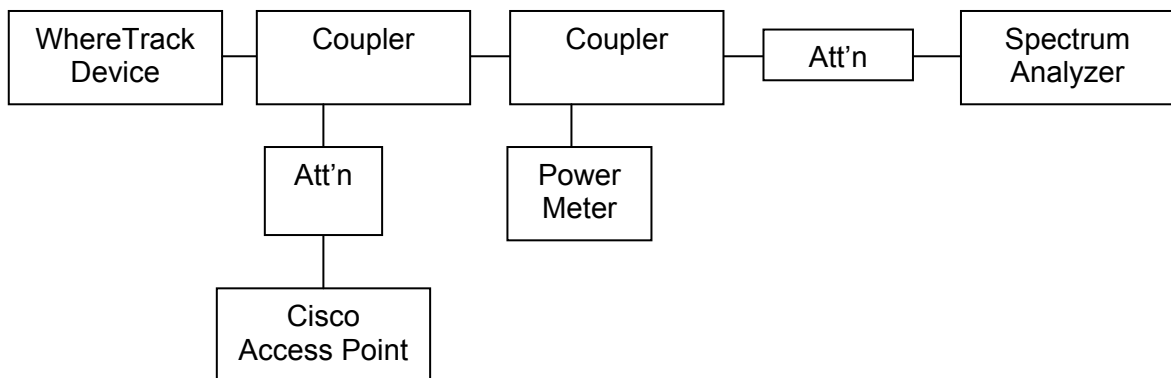

Measurement set up for Transmitter Peak Output Power

15.247 (c) Operation with directional antenna gains greater than 6 dBi

(1) Fixed point –to-point operation:

(i) Systems operating in the 2400 – 2483.5 MHz band that are used exclusively for fixed, point-to-point operations may employ transmitting antennas with directional gain greater than 6 dBi provided the maximum conducted output power of the intentional radiator is reduced by 1 dB for every 3 dB that the directional gain of the antenna exceeds 6 dBi.

Antenna Type	Gain (dBi)	Antenna Gain >6dBi (dB)	Max. Allowable Peak Power (dBm)	Maximum EIRP (dBm)
Whip Dipole	+5.0	No	30	36



Ambient conditions.

Temperature: 17 to 23 °C Relative humidity: 31 to 57 % Pressure: 999 to 1012 mbar

TABLE OF RESULTS – 802.11b

Center Frequency (MHz)	99% Measurement Bandwidth (MHz)	Peak Power (dBm)	EIRP (dBm)
2,412	15.631	+17.66	+22.66
2,437	15.531	+17.92	+22.92
2,462	15.531	+16.85	+21.85

2412 MHz Peak Power (dBm)

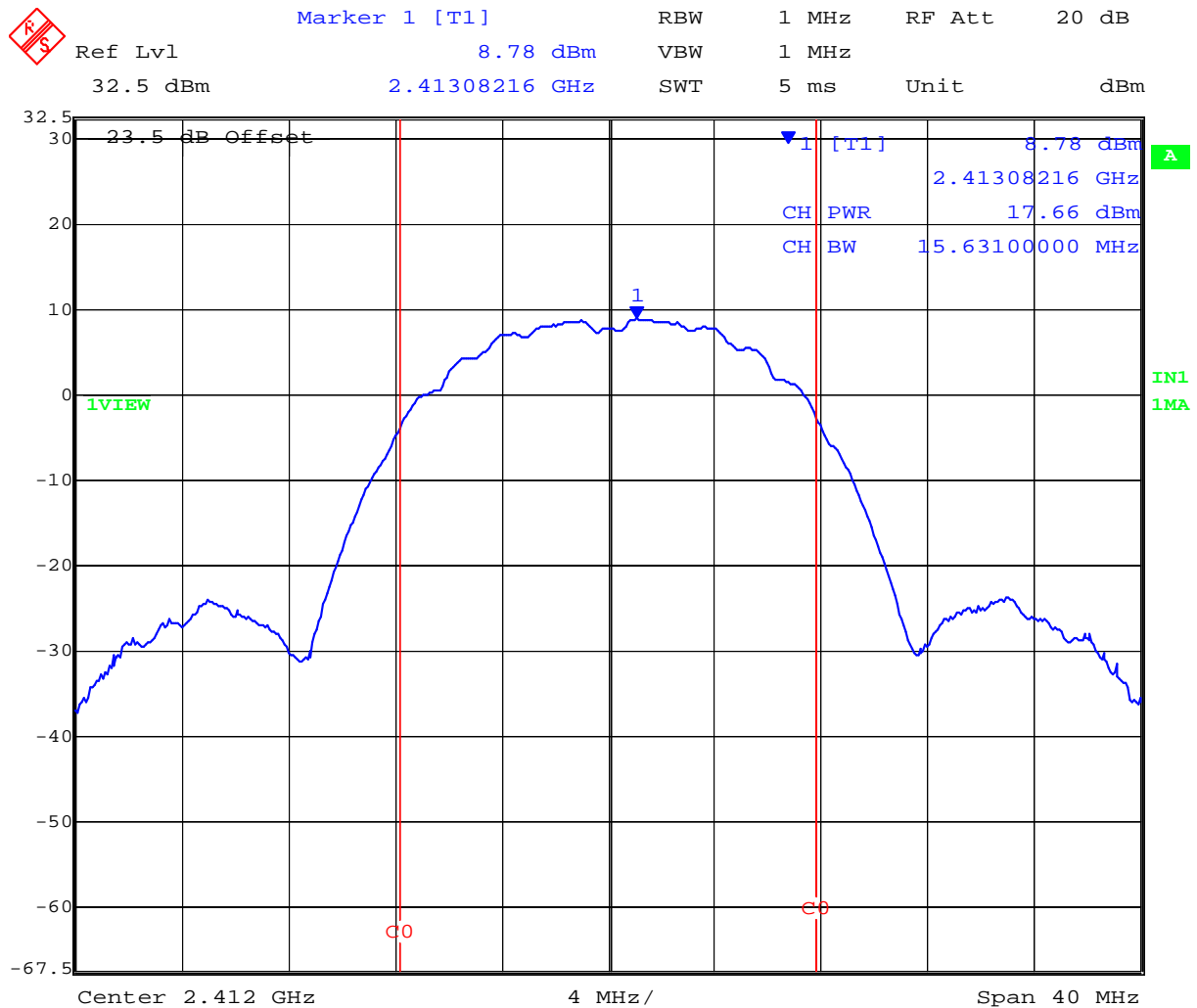

Date: 29.JAN.2009 11:14:26

This test report may be reproduced in full only. The document may only be updated by MiCOM Labs personnel. Any changes will be noted in the Document History section of the report.



2437 MHz Peak Power (dBm)

	Marker 1 [T1]	RBW	1 MHz	RF Att	20 dB
Ref Lvl	9.00 dBm	VBW	1 MHz		
32.5 dBm	2.43808216 GHz	SWT	5 ms	Unit	dBm

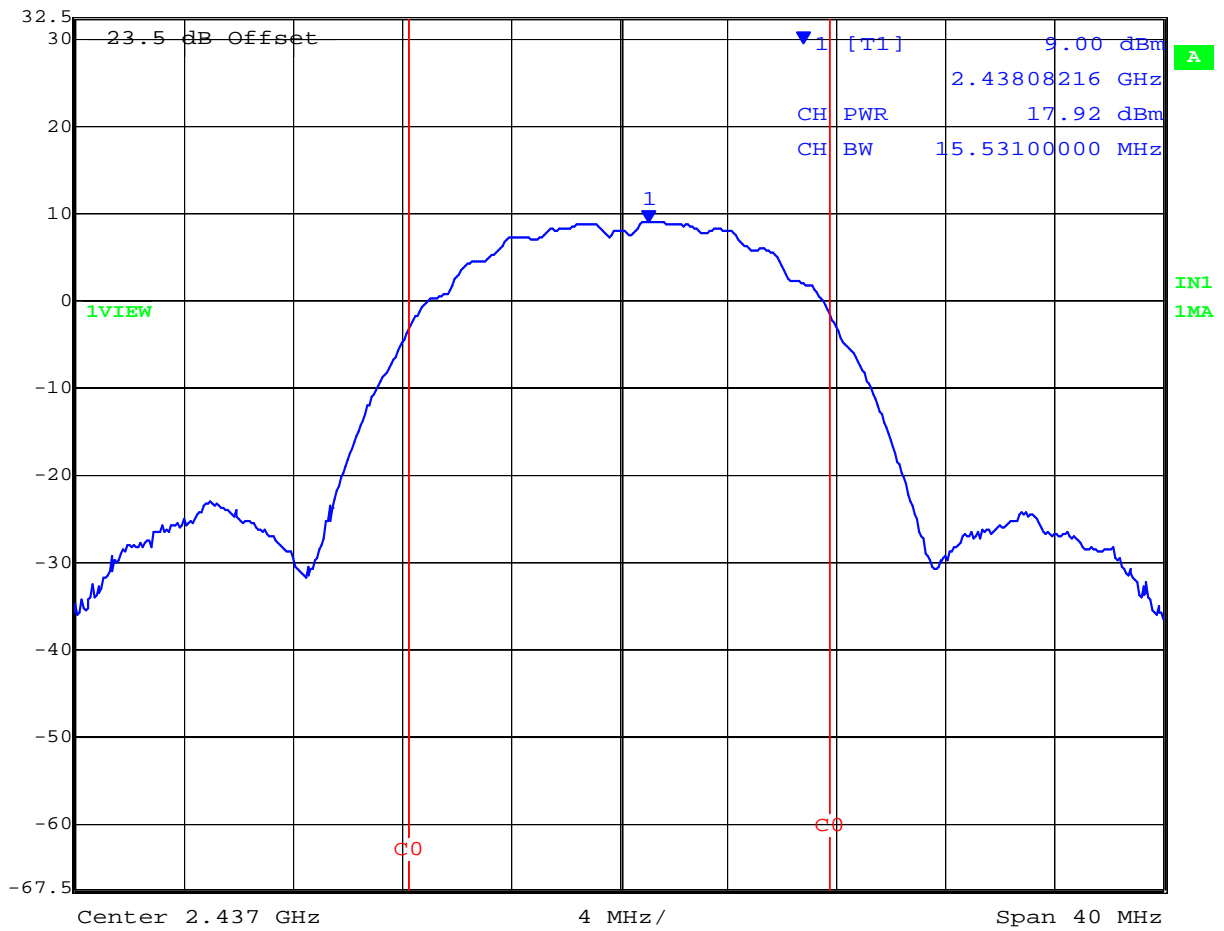

Date: 29.JAN.2009 11:15:40

This test report may be reproduced in full only. The document may only be updated by MiCOM Labs personnel. Any changes will be noted in the Document History section of the report.



2462 MHz Peak Power (dBm)

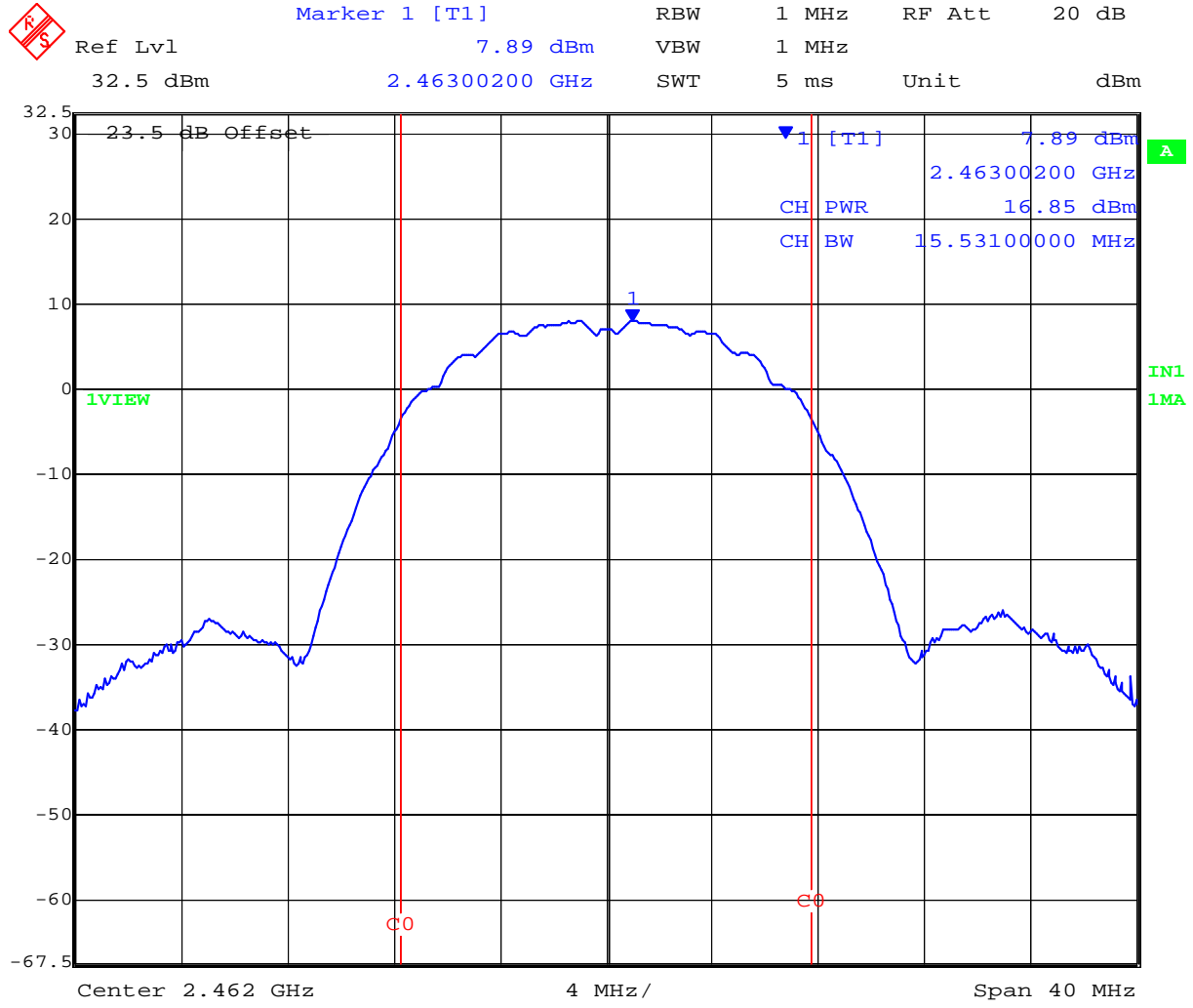

Date: 29.JAN.2009 11:16:59

This test report may be reproduced in full only. The document may only be updated by MiCOM Labs personnel. Any changes will be noted in the Document History section of the report.



TABLE OF RESULTS – 802.11g

Center Frequency (MHz)	99% Measurement Bandwidth (MHz)	Peak Power (dBm)	EIRP (dBm)
2,412	16.733	+20.38	+25.38
2,437	16.834	+22.18	+27.18
2,462	16.633	+18.54	+23.54

2412 MHz Peak Power (dBm)

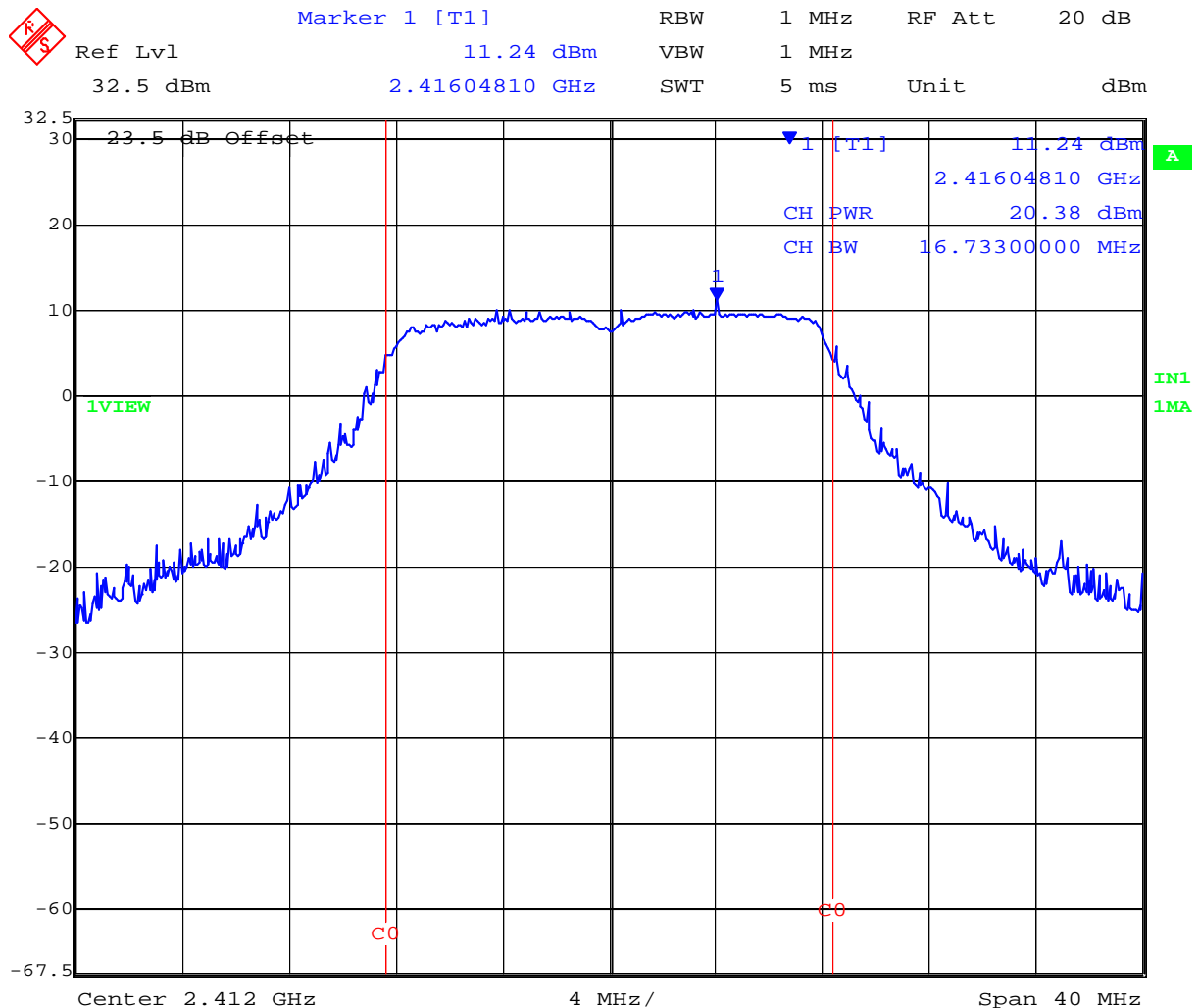

Date: 29.JAN.2009 11:21:31

This test report may be reproduced in full only. The document may only be updated by MiCOM Labs personnel. Any changes will be noted in the Document History section of the report.



Title: WhereTrack WTK-5000
To: FCC 47 CFR Part 15.247 & IC RSS-210
Serial #: ETSD15-A2 Rev A
Issue Date: 6th February '09
Page: 32 of 97

2437 MHz Peak Power (dBm)

	Marker 1 [T1]	RBW	1 MHz	RF Att	20 dB
Ref Lvl	11.73 dBm	VBW	1 MHz		
32.5 dBm	2.43944489 GHz	SWT	5 ms	Unit	dBm

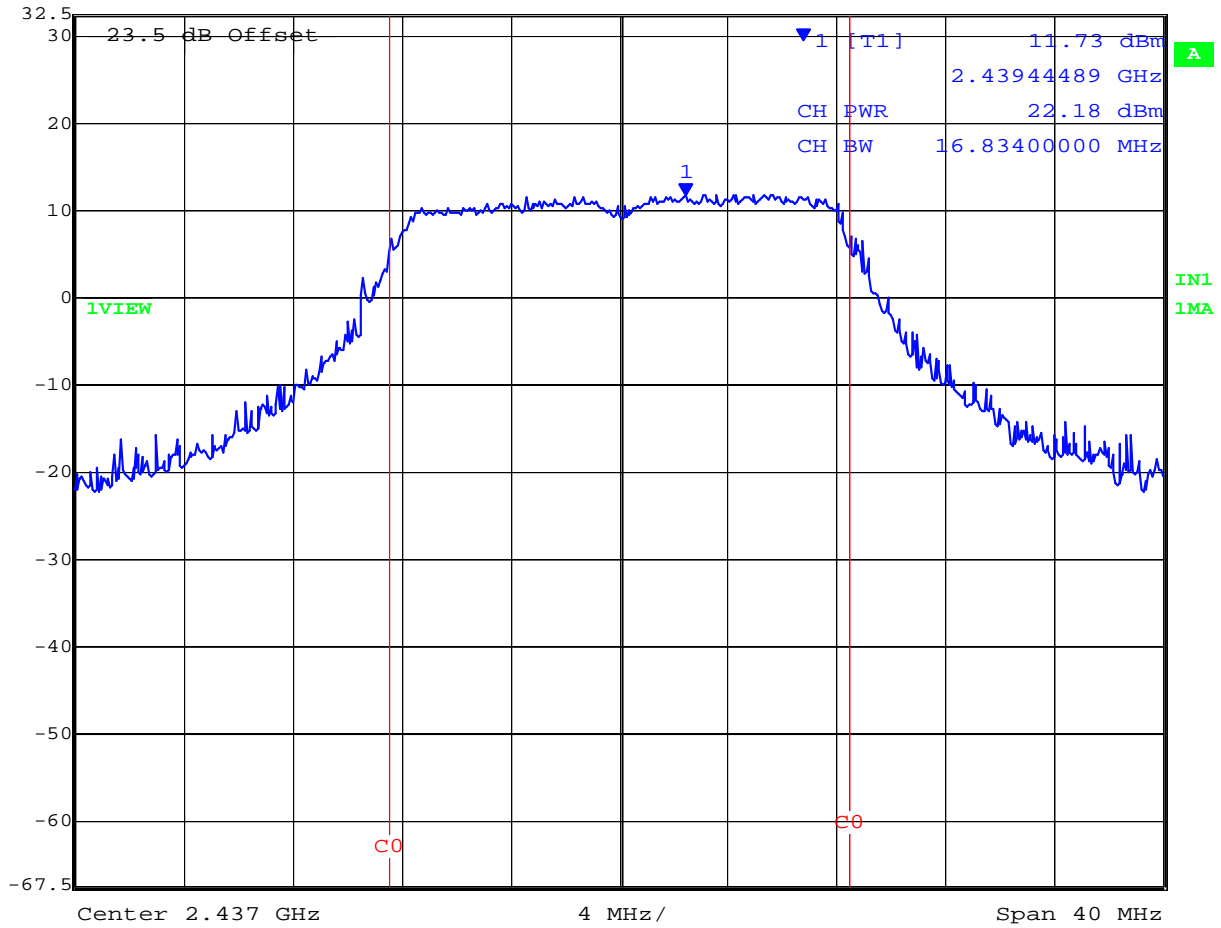

Date: 29.JAN.2009 11:20:33

This test report may be reproduced in full only. The document may only be updated by MiCOM Labs personnel. Any changes will be noted in the Document History section of the report.



2462 MHz Peak Power (dBm)

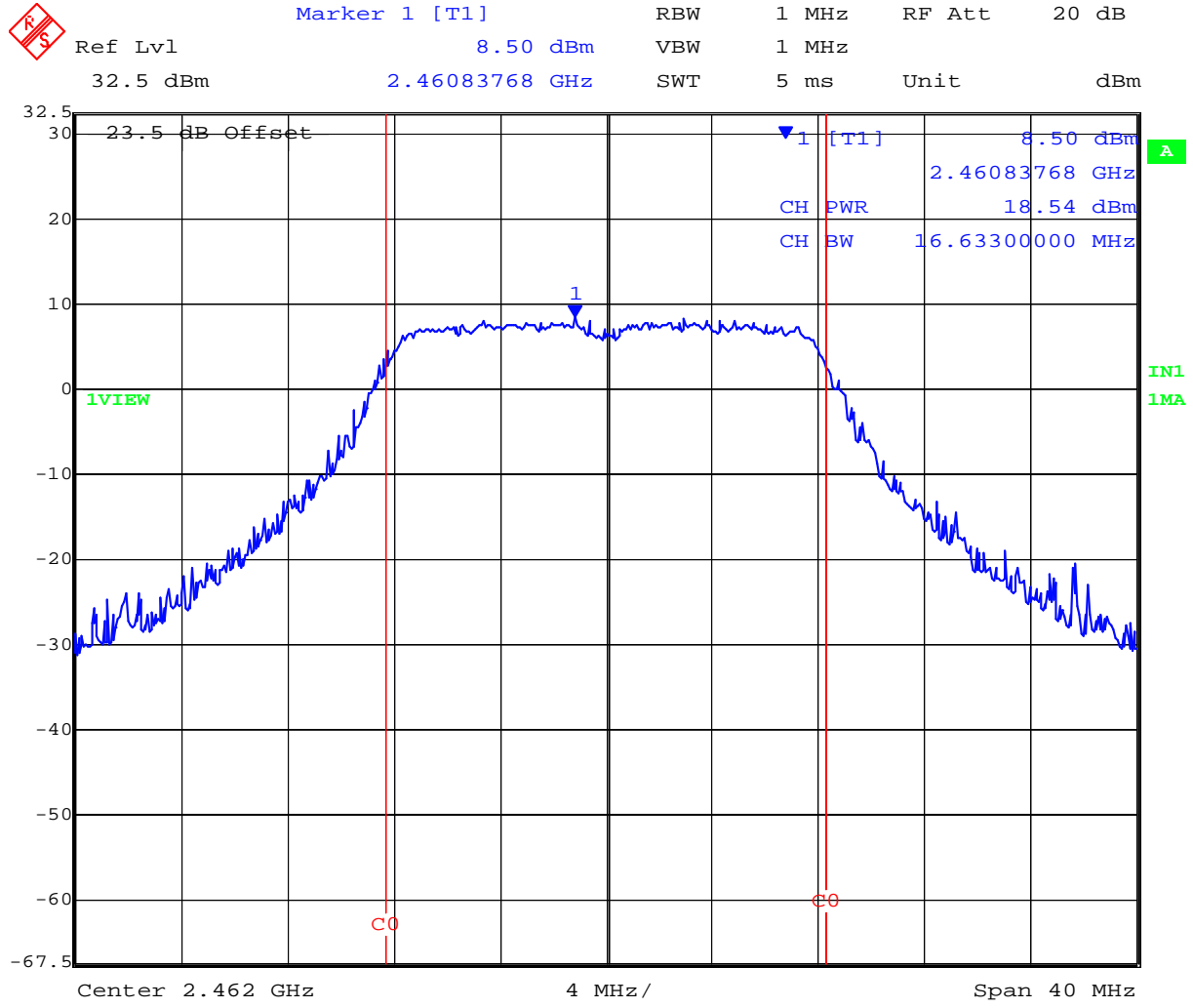

Date: 29.JAN.2009 11:18:05

This test report may be reproduced in full only. The document may only be updated by MiCOM Labs personnel. Any changes will be noted in the Document History section of the report.



TABLE OF RESULTS – DSSS

Center Frequency (MHz)	99% Measurement Bandwidth (MHz)	Peak Power (dBm)	EIRP (dBm)
2441.75	48.096	+21.02	+26.02

DSSS 2441.75 MHz Peak Power (dBm)

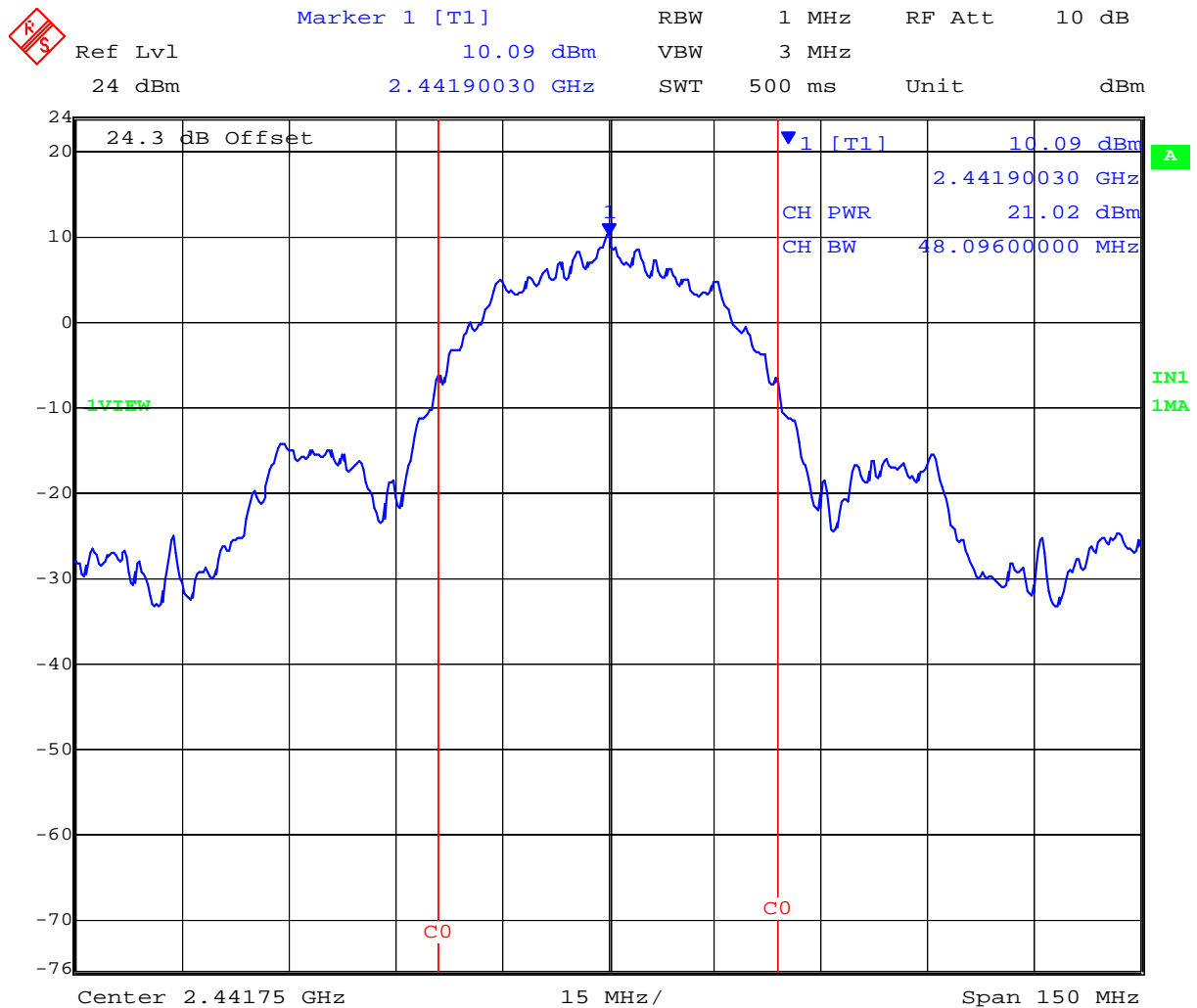

Date: 5.SEP.2007 18:43:27

This test report may be reproduced in full only. The document may only be updated by MiCOM Labs personnel. Any changes will be noted in the Document History section of the report.



Title: WhereTrack WTK-5000
To: FCC 47 CFR Part 15.247 & IC RSS-210
Serial #: ETSD15-A2 Rev A
Issue Date: 6th February '09
Page: 35 of 97

Specification

Limits

§15.247 (b) The maximum peak output power of the intentional radiator shall not exceed the following:

§15.247 (b) (3) For systems using digital modulation in the 902-928 MHz, 2400-2483.5 MHz and 5725-5850 MHz bands: 1.0 watt.

§15.31 (e) For intentional radiators, measurements of the variation of the input power or the radiated signal level of the fundamental frequency component of the emission, as appropriate, shall be performed with the supply voltage varied between 85% and 115% of the nominal rated supply voltage. For battery operated equipment, the equipment tests shall be performed using a new battery.

§ RSS-210 A8.4(4) For systems employing digital modulation techniques operating in the 902-928 MHz, 2400-2483.5 MHz and 5725-5850 MHz bands the maximum peak conducted power shall not exceed 1 watt.

Laboratory Measurement Uncertainty for Power Measurements

Measurement uncertainty	±1.33 dB
-------------------------	----------

Traceability

Method	Test Equipment Used
Measurements were made per work instruction WI-01 'Measuring RF Output Power'	0158, 0193, 0252, 0313, 0314, 0070, 0116, 0117

This test report may be reproduced in full only. The document may only be updated by MiCOM Labs personnel. Any changes will be noted in the Document History section of the report.

5.1.3. Peak Power Spectral Density

FCC, Part 15 Subpart C §15.247(e)
Industry Canada RSS-210 §A8.2

Test Procedure

The transmitter output was connected to a spectrum analyzer and the maximum level in a 3 kHz bandwidth was measured. A peak value was found over the full emission bandwidth and the frequency span reduced to obtain enhanced resolution. Sweep time => span / 3 kHz with video averaging turned off. The Peak Power Spectral Density is the highest level found across the emission in a 3 kHz resolution bandwidth.

Test Measurement Set up

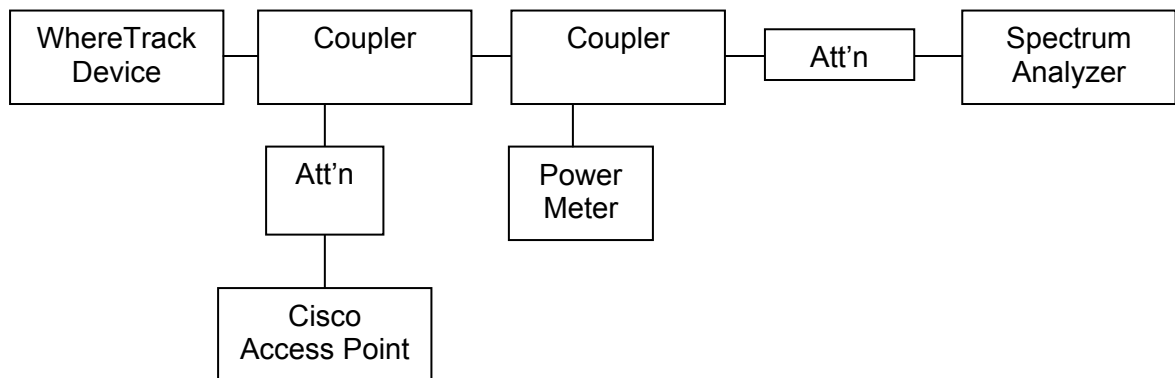

Measurement set up for Peak Power Spectral Density

Measurement Results for Peak Power Spectral Density

Ambient conditions.

Temperature: 17 to 23 °C Relative humidity: 31 to 57 % Pressure: 999 to 1012 mbar

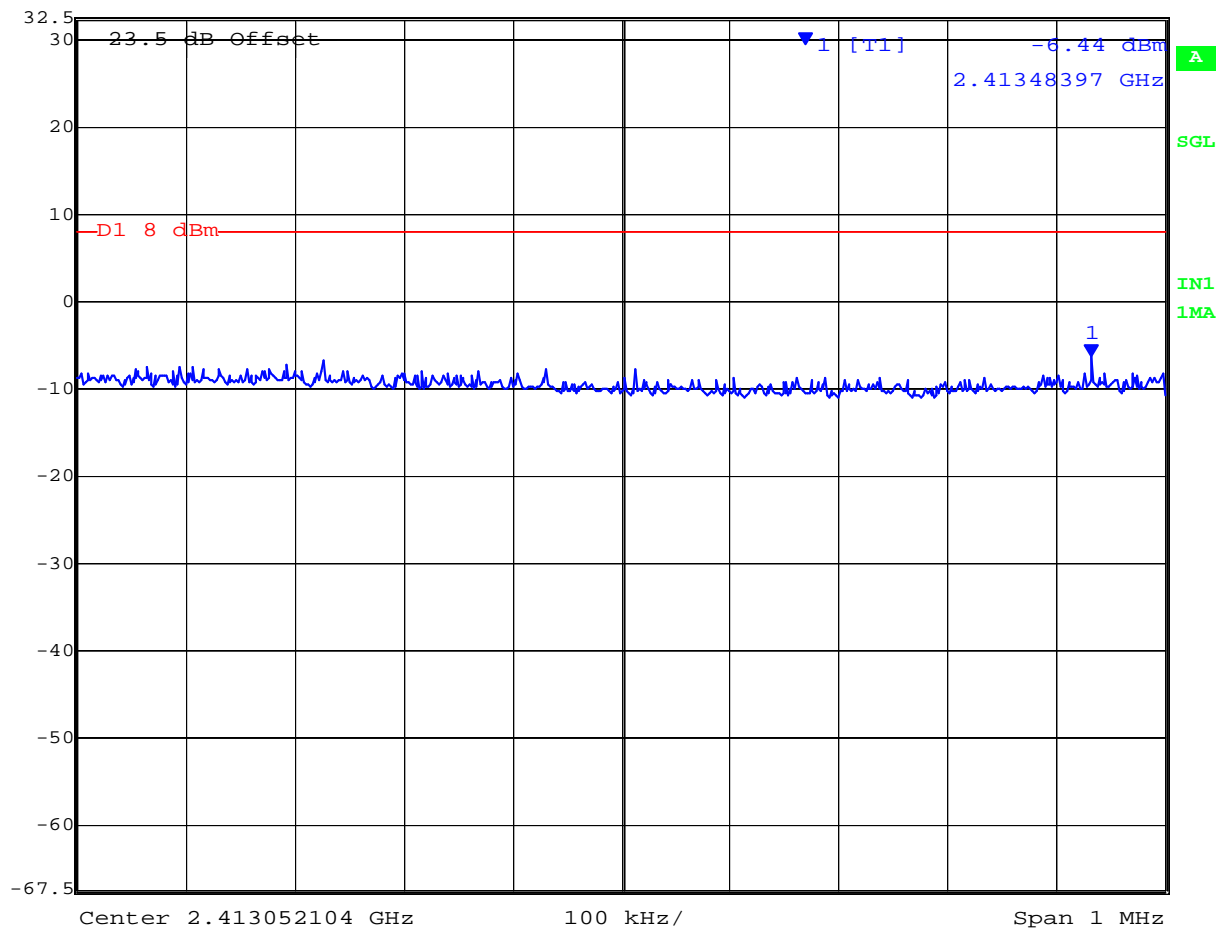

TABLE OF RESULTS – 802.11b

Center Frequency (MHz)	Peak Frequency (MHz)	PPSD (dBm)	Limit (dBm)	Margin (dBm)
2412	2413.48397	-6.44	+8	-14.44
2437	2437.69038	-6.63	+8	-14.63
2462	2462.73046	-8.05	+8	-16.05

Peak Power Spectral Density
Ch 1 2412 MHz 802.11b

 Marker 1 [T1] RBW 3 kHz RF Att 20 dB
 Ref Lvl -6.44 dBm VBW 10 kHz
 32.5 dBm 2.41348397 GHz SWT 500 s Unit dBm



Date: 29.JAN.2009 10:18:46

This test report may be reproduced in full only. The document may only be updated by MiCOM Labs personnel. Any changes will be noted in the Document History section of the report.



Peak Power Spectral Density
Ch 6 2437 MHz 802.11b

 Ref Lvl 32.5 dBm
Marker 1 [T1] 2.43769038 GHz
RBW 3 kHz RF Att 20 dB
VBW 10 kHz
SWT 500 s Unit dBm

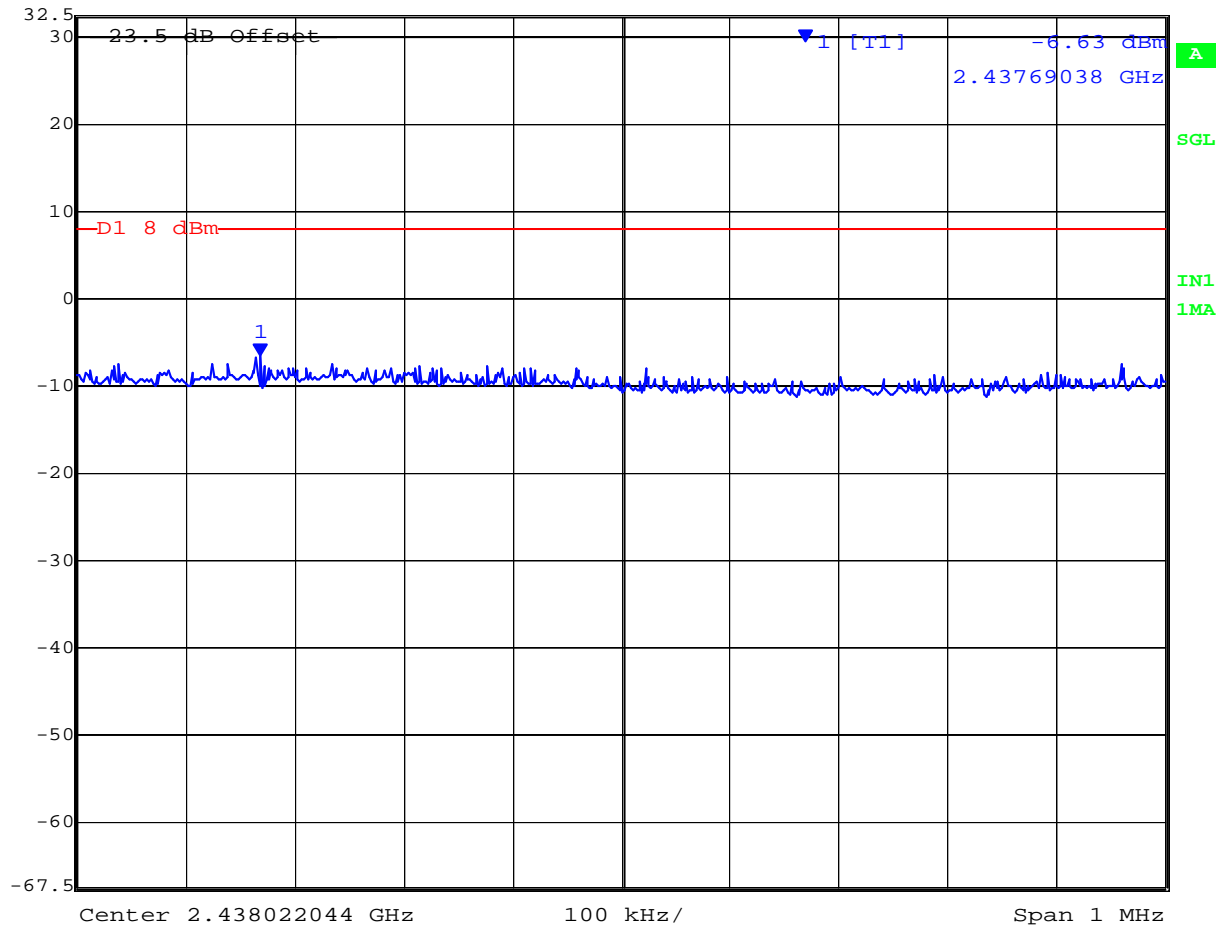

Date: 29.JAN.2009 10:28:52

This test report may be reproduced in full only. The document may only be updated by MiCOM Labs personnel. Any changes will be noted in the Document History section of the report.



Title: WhereTrack WTK-5000
To: FCC 47 CFR Part 15.247 & IC RSS-210
Serial #: ETSD15-A2 Rev A
Issue Date: 6th February '09
Page: 39 of 97

Peak Power Spectral Density Ch 11 2462 MHz 802.11b

 Ref Lvl 32.5 dBm
Marker 1 [T1] 2.46273046 GHz
RBW 3 kHz
RF Att 20 dB
VBW 10 kHz
SWT 500 s
Unit dBm

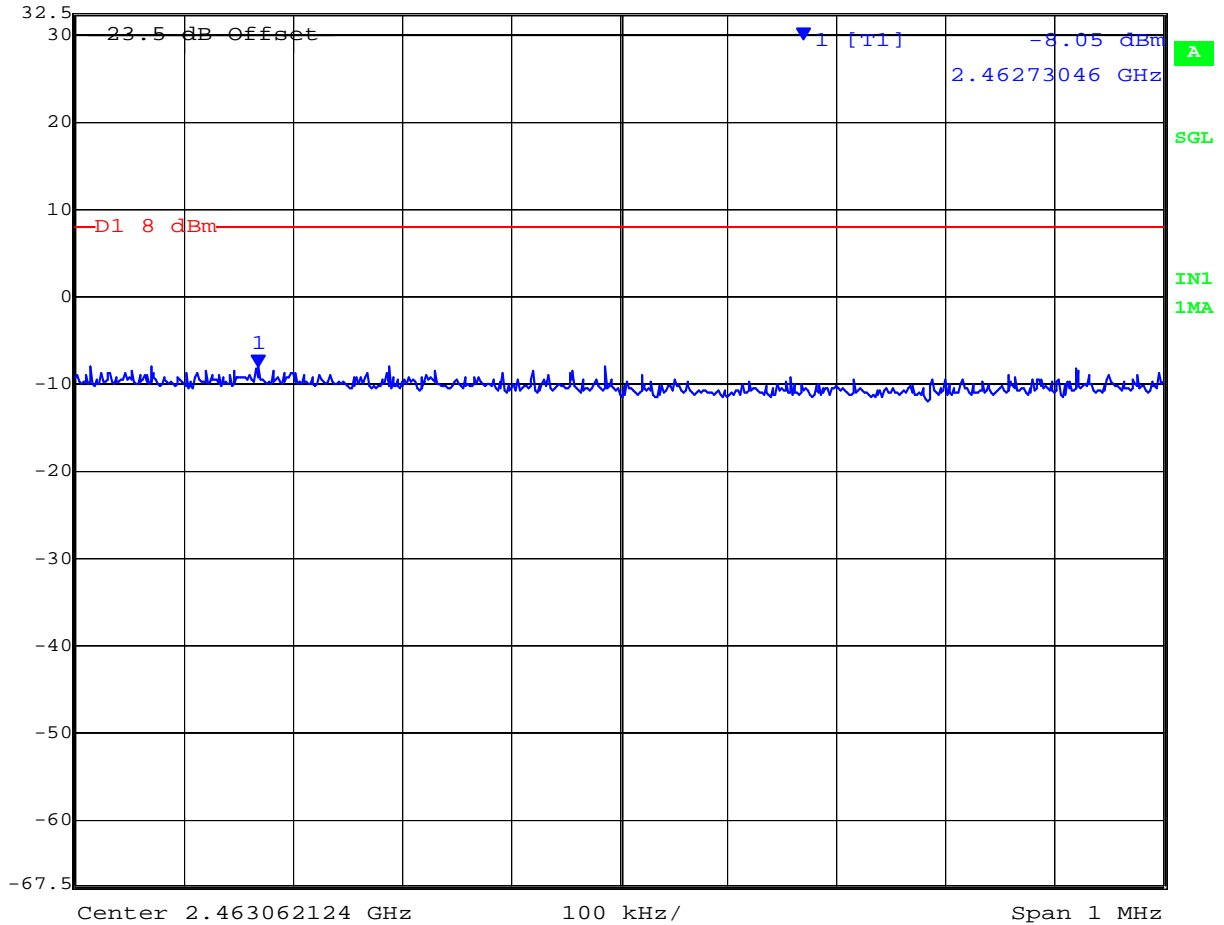

Date: 29.JAN.2009 10:39:02

This test report may be reproduced in full only. The document may only be updated by MiCOM Labs personnel. Any changes will be noted in the Document History section of the report.



TABLE OF RESULTS – 802.11g

Center Frequency (MHz)	Peak Frequency (MHz)	PPSD (dBm)	Limit (dBm)	Margin (dBm)
2412	2415.73246	-9.18	+8	-17.18
2437	2441.98096	-7.03	+8	-15.03
2462	2463.23146	-11.31	+8	-19.31

Peak Power Spectral Density
Ch 1 2412 MHz 802.11g

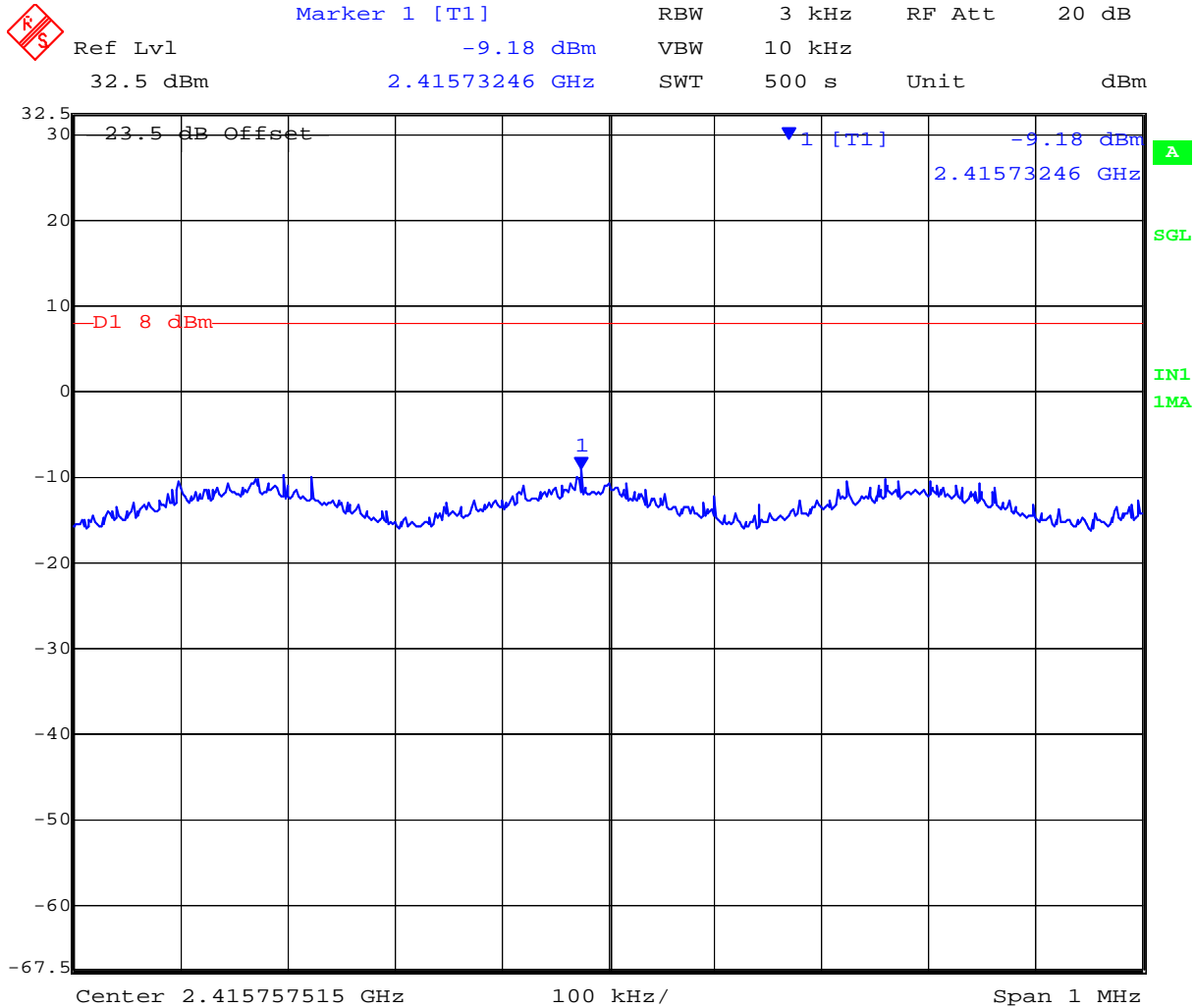

Date: 29.JAN.2009 11:11:02

This test report may be reproduced in full only. The document may only be updated by MiCOM Labs personnel. Any changes will be noted in the Document History section of the report.



Title: WhereTrack WTK-5000
To: FCC 47 CFR Part 15.247 & IC RSS-210
Serial #: ETSD15-A2 Rev A
Issue Date: 6th February '09
Page: 41 of 97

Peak Power Spectral Density Ch 6 2437 MHz 802.11g

 Ref Lvl 32.5 dBm
Marker 1 [T1] 2.44198096 GHz
RBW 3 kHz RF Att 20 dB
VBW 10 kHz
SWT 500 s Unit dBm

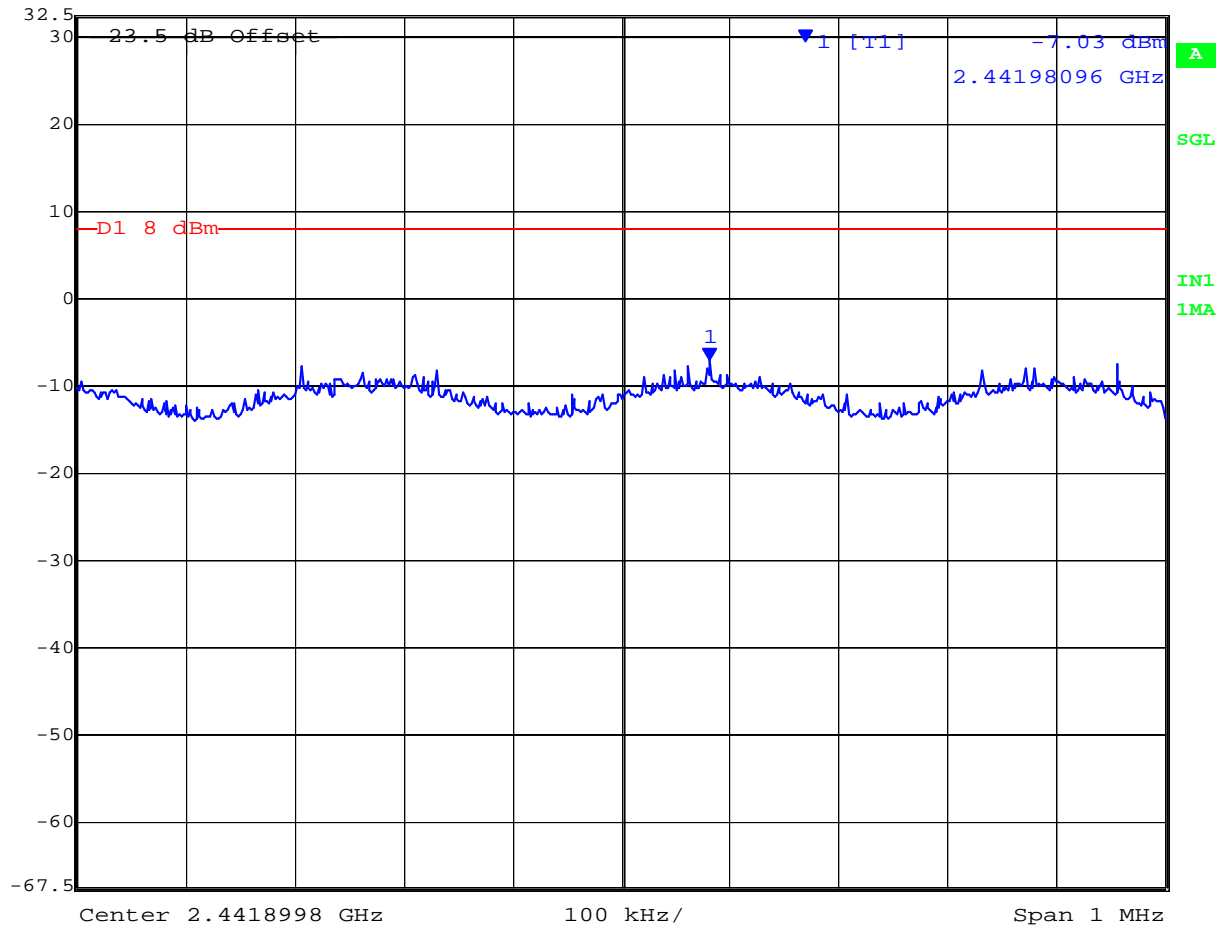

Date: 29.JAN.2009 10:59:54

This test report may be reproduced in full only. The document may only be updated by MiCOM Labs personnel. Any changes will be noted in the Document History section of the report.



Peak Power Spectral Density Ch 11 2462 MHz 802.11g

 Ref Lvl 32.5 dBm
Marker 1 [T1] -11.31 dBm 2.46323146 GHz
RBW 3 kHz RF Att 20 dB
VBW 10 kHz
SWT 500 s Unit dBm

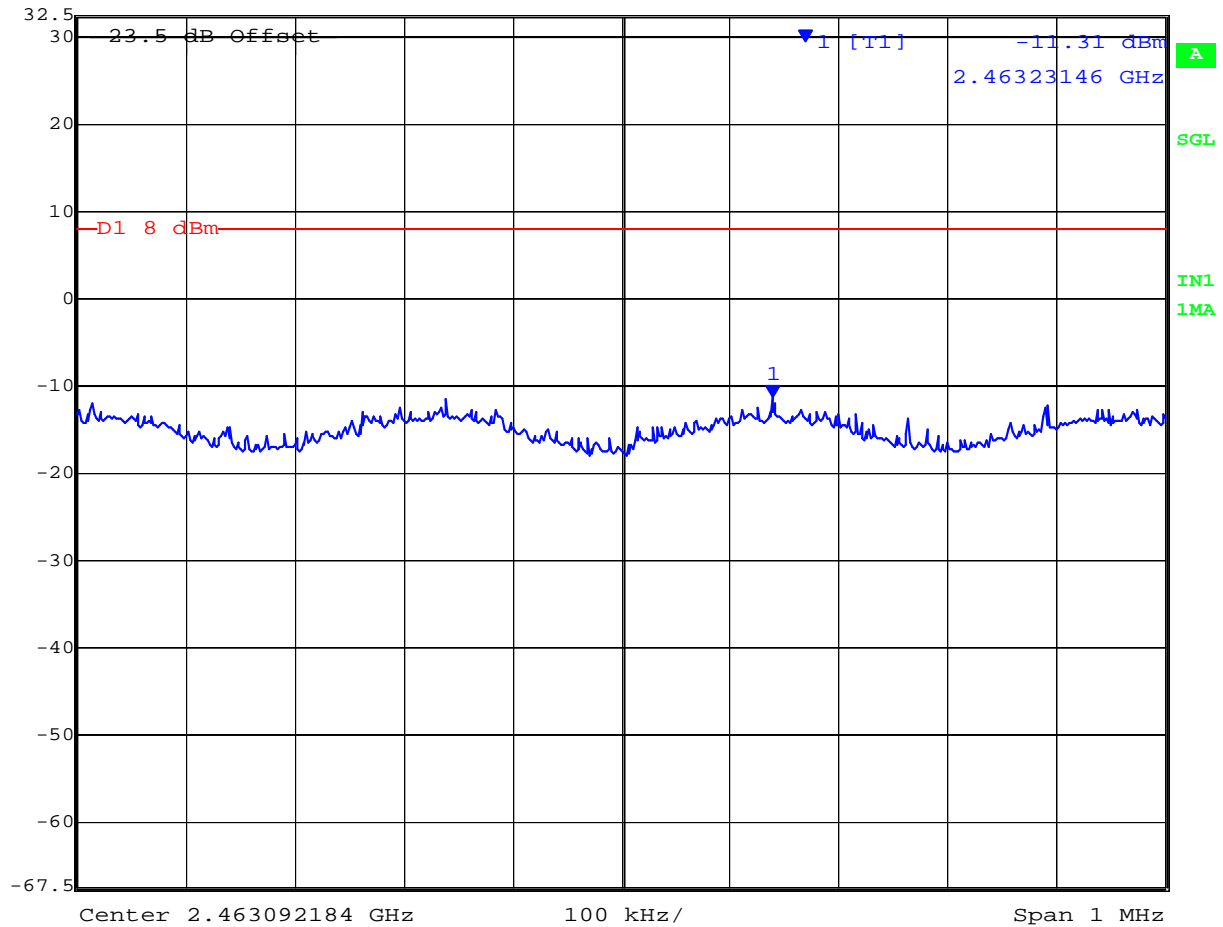

Date: 29.JAN.2009 10:49:17

This test report may be reproduced in full only. The document may only be updated by MiCOM Labs personnel. Any changes will be noted in the Document History section of the report.



Title: WhereTrack WTK-5000
To: FCC 47 CFR Part 15.247 & IC RSS-210
Serial #: ETSD15-A2 Rev A
Issue Date: 6th February '09
Page: 44 of 97

Specification
Peak Power Spectral Density Limits

§15.247(e) For digitally modulated systems, the power spectral density conducted from the intentional radiator to the antenna shall not be greater than +8 dBm in any 3 kHz band during any time interval of continuous transmission

RSS-210 §A8.2(2) The transmitter power spectral density (into the antenna) shall not be greater than +8 dBm in any 3 kHz band during any time interval of continuous transmission or over 1.0 second if the transmission exceeds 1.0 second duration.

Laboratory Measurement Uncertainty for Spectral Density

Measurement uncertainty	±1.33 dB
-------------------------	----------

Traceability

Method	Test Equipment Used
Measurements were made per work instruction WI-01 'Measuring RF Output Power'	0158, 0193, 0252, 0313, 0314, 0070, 0116, 0117

This test report may be reproduced in full only. The document may only be updated by MiCOM Labs personnel. Any changes will be noted in the Document History section of the report.



5.1.4. Maximum Permissible Exposure

FCC, Part 15 Subpart C §15.247(i)
Industry Canada RSS-Gen §5.5

Calculations for Maximum Permissible Exposure Levels

Power Density = Pd (mW/cm²) = EIRP/(4πd²)

EIRP = P * G

P = Peak output power (mW)

G = Antenna numeric gain (numeric)

d = Separation distance (cm)

Numeric Gain = 10 ^ (G (dBi)/10)

Because the EUT belongs to the General Population/Uncontrolled Exposure the limit of power density is 1.0 mW/cm²

Freq. Band (GHz)	Antenna Gain (dBi)	Numeric Gain (numeric)	Peak Output Power (dBm)	Peak Output Power (mW)	Calculated Safe Distance @ 1mW/cm ² Limit(cm)	Minimum Separation Distance (cm)
2.4	5.0	3.16	+22.18	165.2	6.5	20*

***Note:** for mobile or fixed location transmitters the minimum separation distance is 20cm, even if calculations indicate the MPE distance to be less.

Specification

Maximum Permissible Exposure Limits

§15.247(i) Systems operating under the provisions of this section shall be operated in a manner that ensures that the public is not exposed to radio frequency levels in excess of the Commission's guidelines.

FCC §1.1310 Limit = 1mW / cm² from 1.310 Table 1

RSS-Gen §5.5 Before equipment certification is granted, the applicable requirements of RSS-102 shall be met.

Laboratory Measurement Uncertainty for Power Measurements

Measurement uncertainty	±1.33 dB
-------------------------	----------

5.1.5. Conducted Spurious Emissions

FCC, Part 15 Subpart C §15.247(d); 15.205; 15.209
Industry Canada RSS-210 §A8.5, §2.2
Industry Canada RSS-Gen 4.7

Test Procedure

Conducted emissions were measured at a limit of 20 dB below the highest in-band spectral density measured with a spectrum analyzer connected to the antenna terminal. Emissions at the band edge were measured and recorded. Measurements were made while EUT was operating in transmit mode of operation at the appropriate center frequency.

Test Measurement Set up

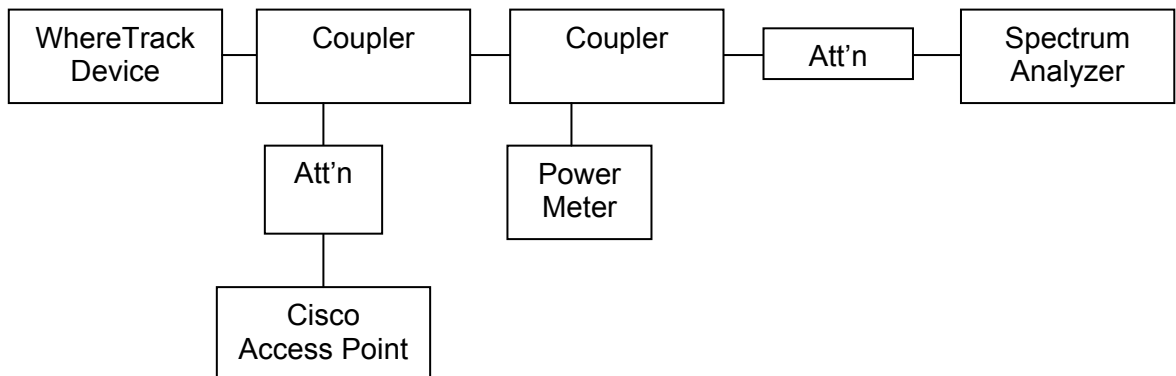

Band-edge measurement test configuration

Measurement Results of Conducted Spurious Emissions

Ambient conditions.

Temperature: 17 to 23 °C Relative humidity: 31 to 57 % Pressure: 999 to 1012 mbar



Conducted Band-Edge Results

Measurements were performed with the transmitter tuned to the channel closest to the band-edge being measured. All emissions were maximized during measurement. Limits which were derived from the band-edge measurements provided below are drawn on each plot.

TABLE OF RESULTS – 802.11b

Center Frequency (MHz)	Band edge Frequency (MHz)	Limit (20 dB below peak of fundamental) (dBm)	Amplitude @ Band edge (dBm)	Margin (dB)
2412	2,400	-14.40	-34.20	-19.80
2462	2,483.5	-15.24	-43.59	-28.35

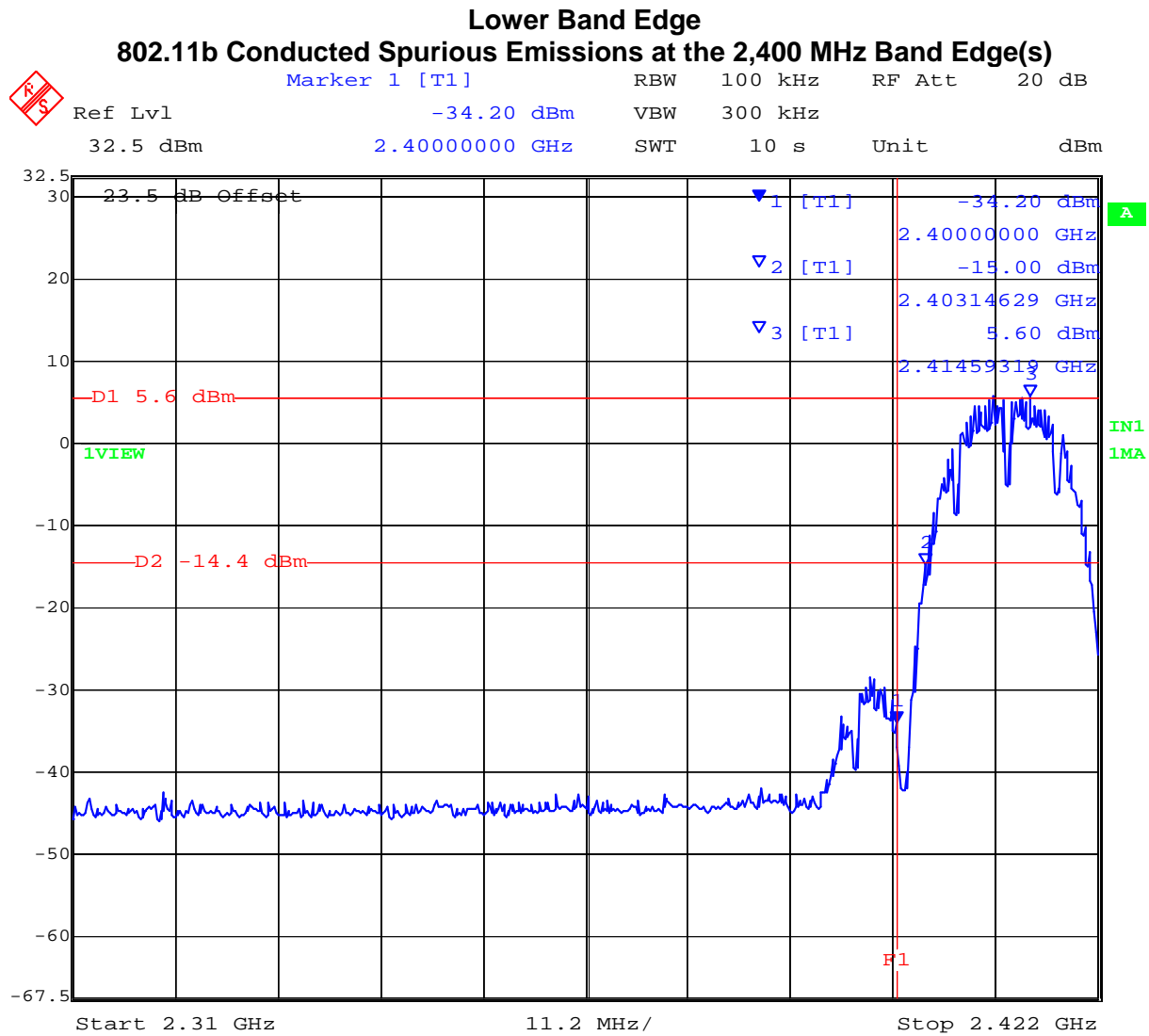

Date: 29.JAN.2009 11:25:33

This test report may be reproduced in full only. The document may only be updated by MiCOM Labs personnel. Any changes will be noted in the Document History section of the report.



Upper Band Edge 802.11b Conducted Spurious Emissions at the 2483.5 MHz Band Edge(s)

Marker 1 [T1] RBW 100 kHz RF Att 20 dB
Ref Lvl 4.76 dBm VBW 300 kHz
32.5 dBm 2.46044489 GHz SWT 10 s Unit dBm

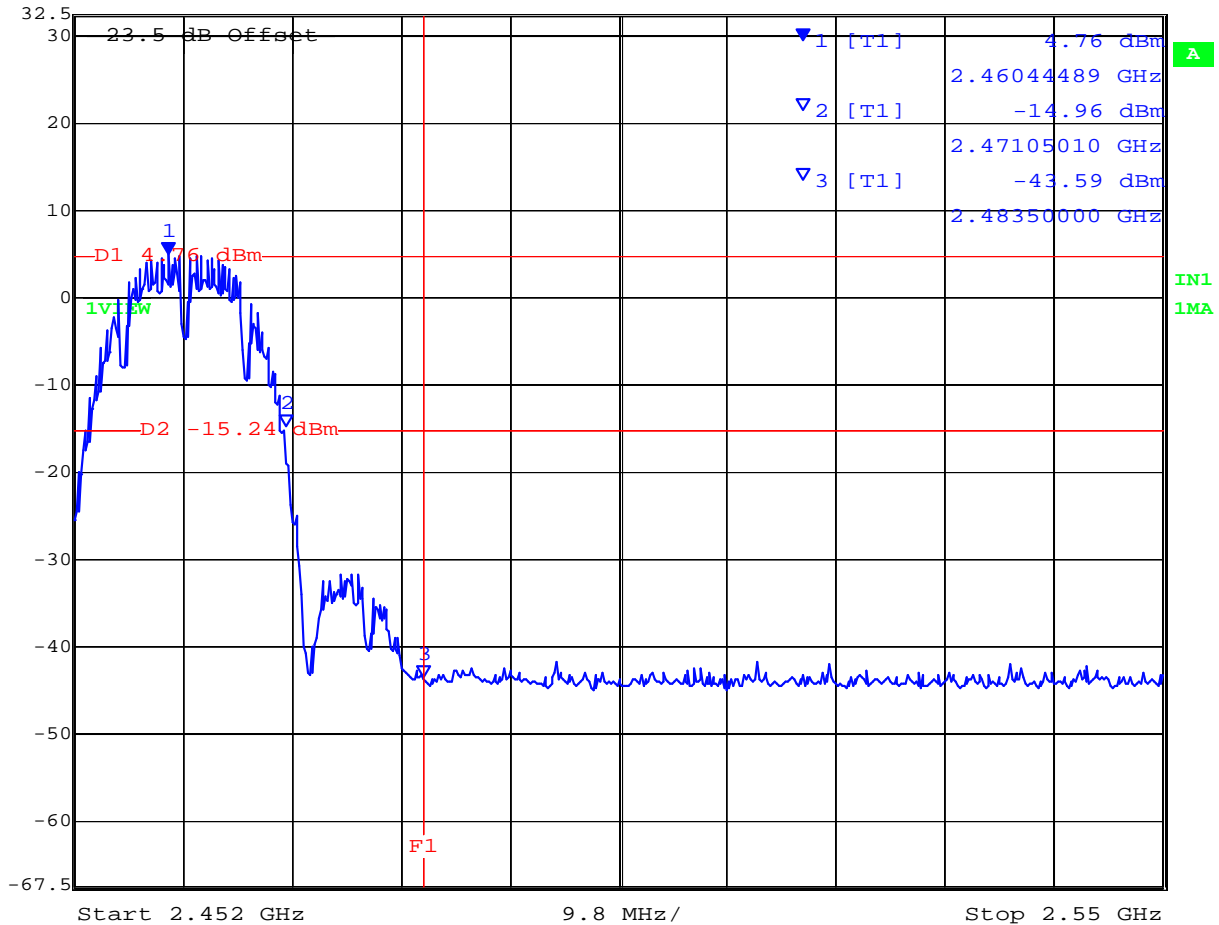

Date: 29.JAN.2009 11:30:06

This test report may be reproduced in full only. The document may only be updated by MiCOM Labs personnel. Any changes will be noted in the Document History section of the report.



TABLE OF RESULTS – 802.11g

Center Frequency (MHz)	Band edge Frequency (MHz)	Limit (20 dB below peak of fundamental) (dBm)	Amplitude @ Band edge (dBm)	Margin (dB)
2412	2,400	-14.40	-26.37	-11.97
2462	2,483.5	-19.86	-41.36	-21.50

Lower Band Edge
802.11b Conducted Spurious Emissions at the 2,400 MHz Band Edge(s)

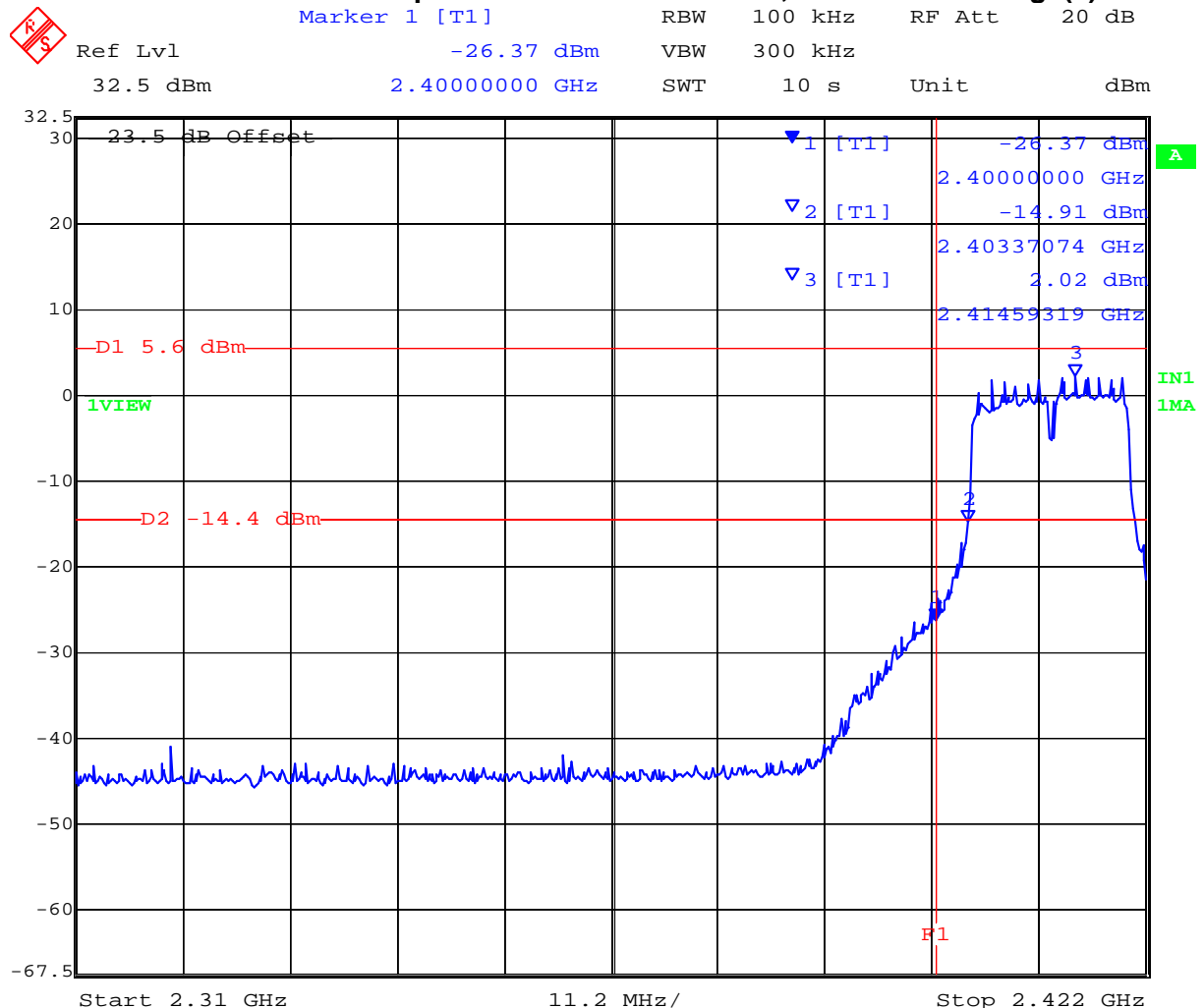

Date: 29.JAN.2009 11:27:23

This test report may be reproduced in full only. The document may only be updated by MiCOM Labs personnel. Any changes will be noted in the Document History section of the report.



Upper Band Edge
802.11g Conducted Spurious Emissions at the 2483.5 MHz Band Edge(s)

	Ref Lvl	0.14 dBm	RBW	100 kHz	RF Att	20 dB
	32.5 dBm	2.46319439 GHz	VBW	300 kHz		
			SWT	10 s	Unit	dBm

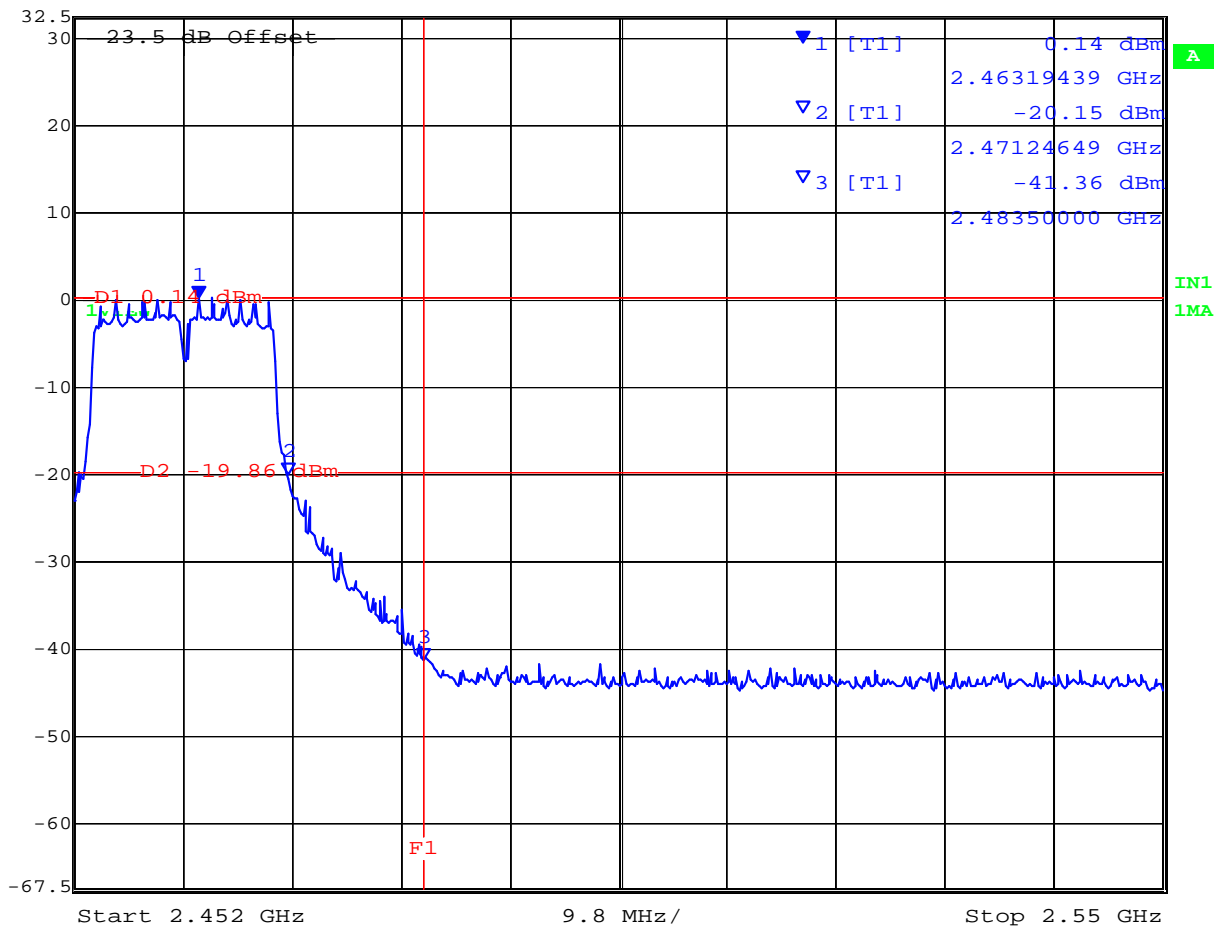

Date: 29.JAN.2009 11:31:36

This test report may be reproduced in full only. The document may only be updated by MiCOM Labs personnel. Any changes will be noted in the Document History section of the report.



TABLE OF RESULTS – DSSS

Center Frequency (MHz)	Band edge Frequency (MHz)	Limit (20 dB below peak of fundamental) (dBm)	Amplitude @ Band edge (dBm)	Margin (dB)
2,441.75	2,400	-20.39	-24.15	-3.76
	2,483.5	-20.39	-27.14	-6.75

DSSS Conducted Spurious Emissions at the 2,400 & 2483.5 MHz Band Edge(s)

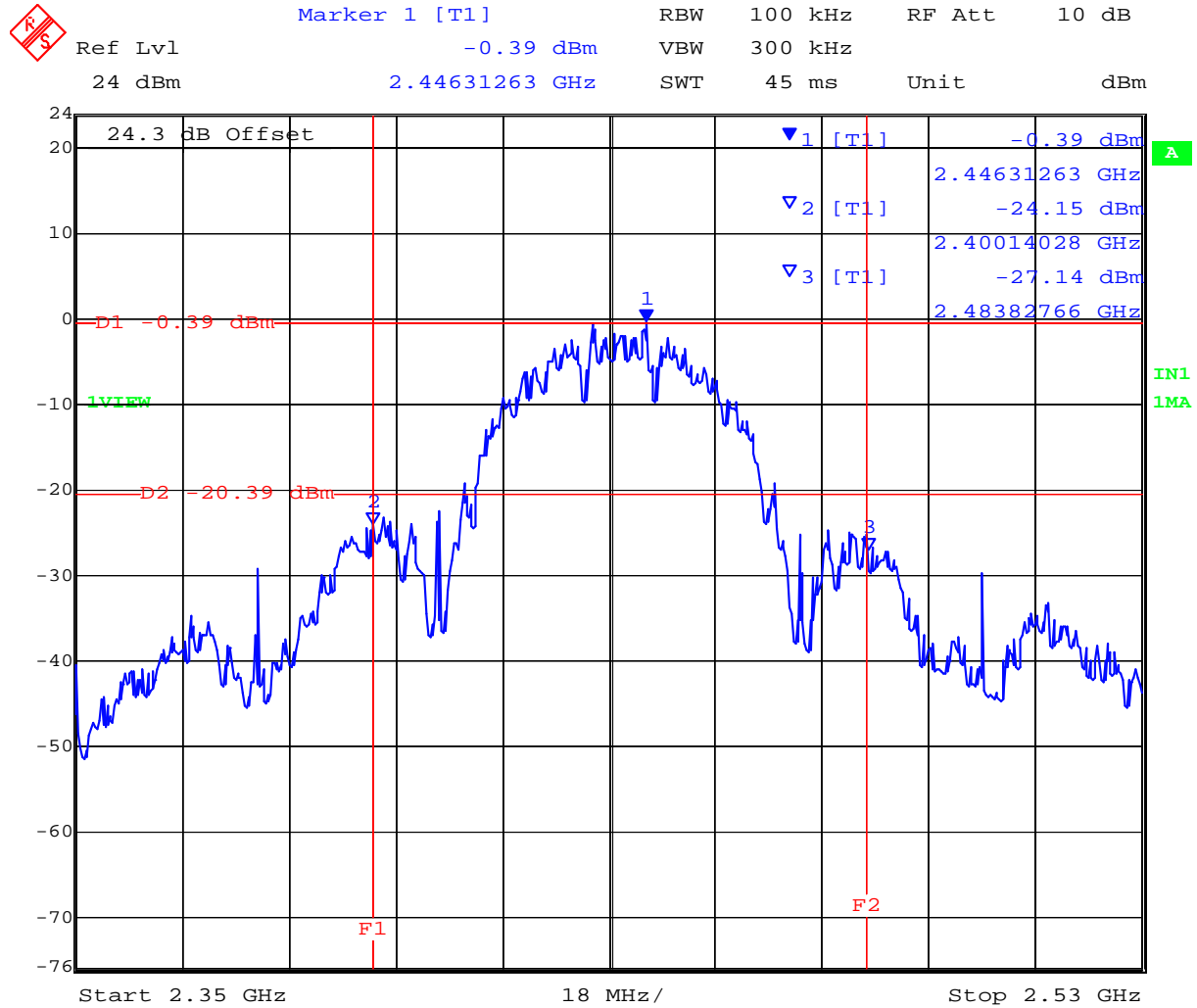

Date: 5.SEP.2007 18:26:45

This test report may be reproduced in full only. The document may only be updated by MiCOM Labs personnel. Any changes will be noted in the Document History section of the report.



Spurious Emissions (0.03-26 GHz)

TABLE OF RESULTS – 802.11b

Channel Centre Frequency (MHz)	Start Frequency (MHz)	Stop Frequency (MHz)	Maximum Emission Observed (dBm)	Limit (dBm)	Margin (dB)
2412	30	26,000	-44.33	-14.40	-29.93
2437	30	26,000	-43.67	-15.43	-28.24
2462	30	26,000	-44.17	-15.24	-28.93

802.11b 2412 MHz Conducted Spurious Emissions 0.03 - 26,000 MHz

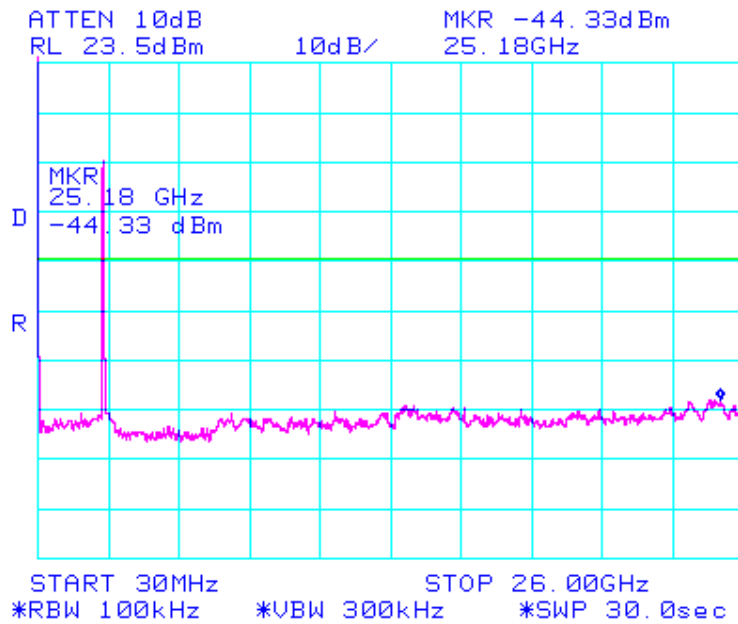

This test report may be reproduced in full only. The document may only be updated by MiCOM Labs personnel. Any changes will be noted in the Document History section of the report.



Title: WhereTrack WTK-5000
To: FCC 47 CFR Part 15.247 & IC RSS-210
Serial #: ETSD15-A2 Rev A
Issue Date: 6th February '09
Page: 55 of 97

TABLE OF RESULTS – 802.11g

Channel Centre Frequency (MHz)	Start Frequency (MHz)	Stop Frequency (MHz)	Maximum Emission Observed (dBm)	Limit (dBm)	Margin (dB)
2412	30	26,000	-44.50	-17.98	-26.52
2437	30	26,000	-43.83	-19.10	-24.73
2462	30	26,000	-44.50	-19.86	-24.64

802.11g 2412 MHz Conducted Spurious Emissions 0.03 - 26,000 MHz

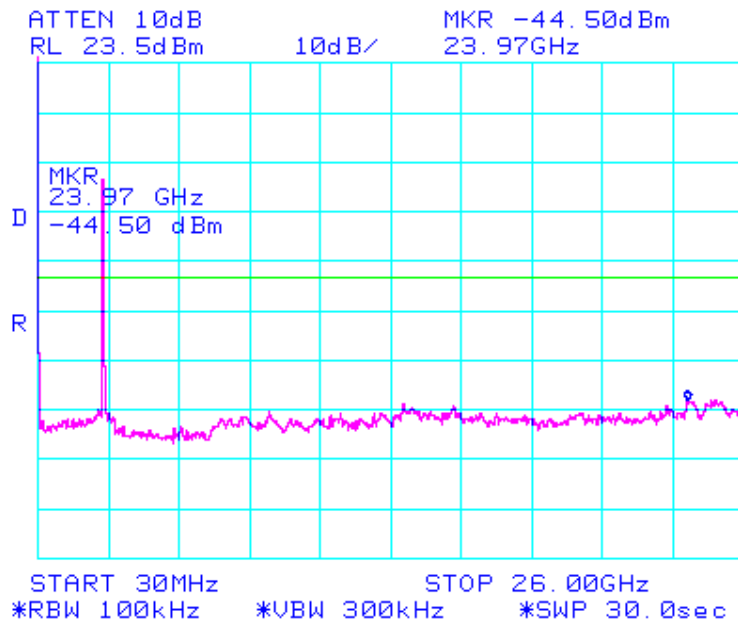

This test report may be reproduced in full only. The document may only be updated by MiCOM Labs personnel. Any changes will be noted in the Document History section of the report.



Spurious Emissions (0.03-26 GHz) - Continued

TABLE OF RESULTS – DSSS

Channel Centre Frequency (MHz)	Start Frequency (MHz)	Stop Frequency (MHz)	Maximum Emission Observed (dBm)	Limit (dBm)	Margin (dB)
2441.75	30	7,000	-48.29	-20.45	-27.84
2441.75	7,000	26,000	-51.90	-20.45	-31.45

DSSS

2441.75 MHz Conducted Spurious Emissions 30 MHz to 7,000 MHz

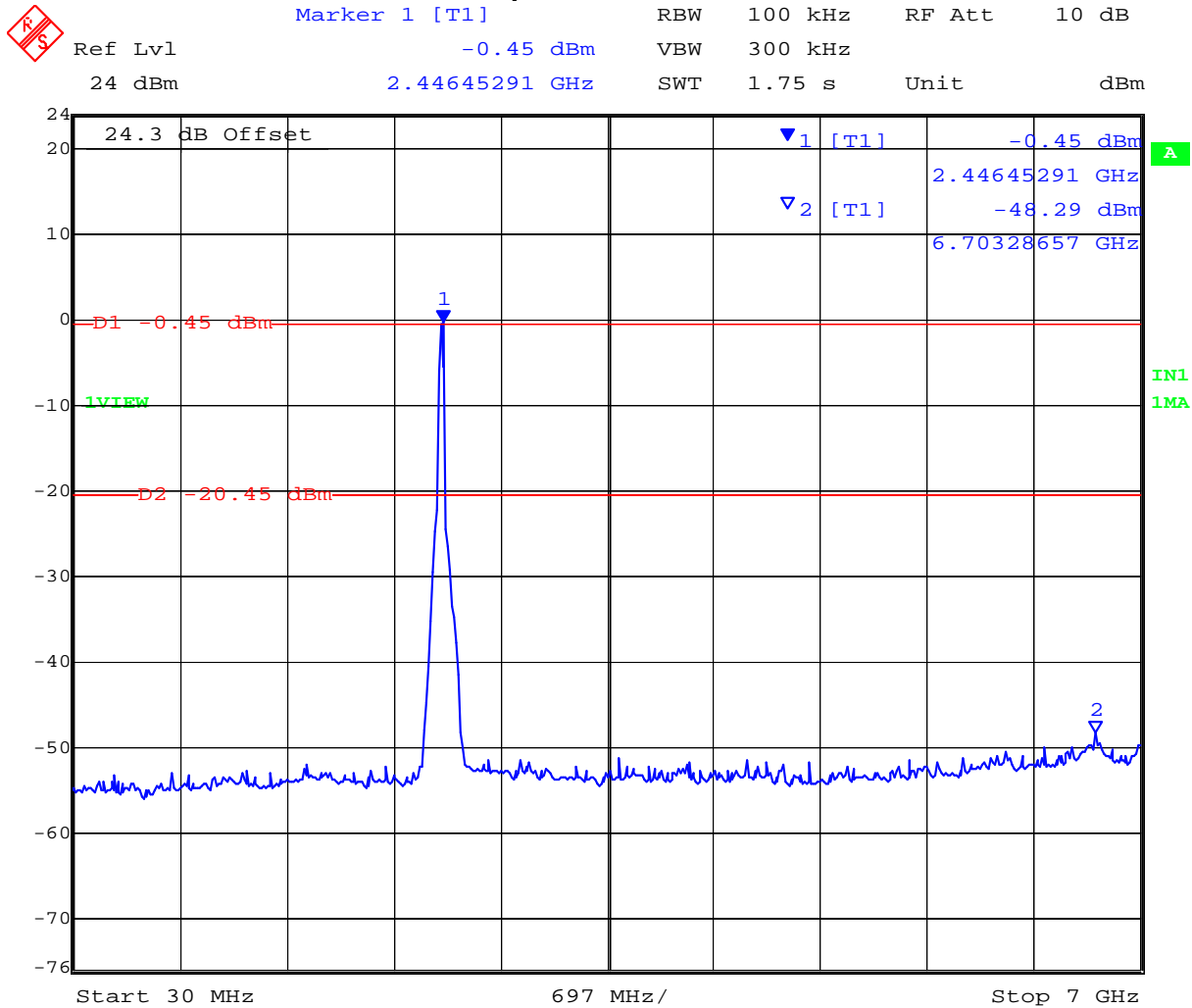

Date: 5.SEP.2007 18:30:21

This test report may be reproduced in full only. The document may only be updated by MiCOM Labs personnel. Any changes will be noted in the Document History section of the report.



Title: WhereTrack WTK-5000
To: FCC 47 CFR Part 15.247 & IC RSS-210
Serial #: ETSD15-A2 Rev A
Issue Date: 6th February '09
Page: 60 of 97

Specification

Limits Band-Edge

Lower Limit Band-edge	Upper Limit Band-edge	Limit below highest level of desired power
2,400 MHz	2,483.5 MHz	≥ 20 dB

§15.247(d) and RSS-210 §A8.5 In any 100 kHz bandwidth outside the frequency band in which the spread spectrum or digitally modulated intentional radiator is operating, the radio frequency power that is produced by the intentional radiator shall be at least 20 dB below that in the 100 kHz bandwidth within the band that contains the highest level of the desired power, based on either an RF conducted or radiated measurement, provided the transmitter demonstrates compliance with the peak conducted power limits.

§15.247(d)

If the transmitter complies with the conducted power limits based on the use of RMS averaging over a time interval, as permitted under paragraph (b)(3) of this section, the attenuation required under this paragraph shall be 30 dB instead of 20 dB. Attenuation below the general limits specified §15.209(a) is not required. In addition, radiated emissions which fall in the restricted bands, as defined in Section §15.205(a), must also comply with the radiated emission limits specified in Section 15.209(a) (see Section 15.205(a)).

RSS-210 §A8.5 If the transmitter complies with the conducted power limits based on the use of RMS averaging over a time interval, as permitted under section A8.4(4), the attenuation required shall be 30 dB instead of 20 dB. Attenuation below the general limits specified in Tables 2 and 3 is not required. In addition, radiated emissions which fall in the restricted bands of Table 1 must also comply with the radiated emission limits specified in Tables 2 and 3.

RSS-Gen §4.7

The search for unwanted emissions shall be from the lowest frequency internally generated or used in the device (local oscillator, intermediate of carrier frequency), or from 30 MHz , whichever is the lowest frequency, to the 5th harmonic of the highest frequency generated without exceeding 40 GHz.

Laboratory Measurement Uncertainty for Conducted Spurious Emissions

Measurement uncertainty	±2.37 dB
-------------------------	----------

Traceability

Method	Test Equipment Used
Measurements were made per work instruction WI-05 'Measurement of Spurious Emissions'	0088, 0158, 0193, 0252, 0313, 0314, 0070, 0116, 0117.

This test report may be reproduced in full only. The document may only be updated by MiCOM Labs personnel. Any changes will be noted in the Document History section of the report.

5.1.6. Radiated Emissions

5.1.6.1. Transmitter Radiated Spurious Emissions (above 1 GHz)

FCC, Part 15 Subpart C §15.247(d) 15.205; 15.209
Industry Canada RSS-210 §A8.5, §2.2, §2.6
Industry Canada RSS-Gen §4.7

Test Procedure

Radiated emissions above 1 GHz are measured in the anechoic chamber at a 3-meter distance on every azimuth in both horizontal and vertical polarities. The emissions are recorded and maximized as a function of azimuth by rotation through 360° with a spectrum analyzer in peak hold mode. Depending on the frequency band spanned a notch filter and waveguide filter was used to remove the fundamental frequency. The highest emissions relative to the limit are listed for each frequency spanned.

All measurements on any frequency or frequencies over 1 MHz are based on the use of measurement instrumentation employing an average detector function. All measurements above 1 GHz were performed using a minimum resolution bandwidth of 1 MHz.

The product was initially tested to find worst case orientation for the maximization of spurious emissions. Worst case orientation was used for all emission testing.

Test Measurement Set up

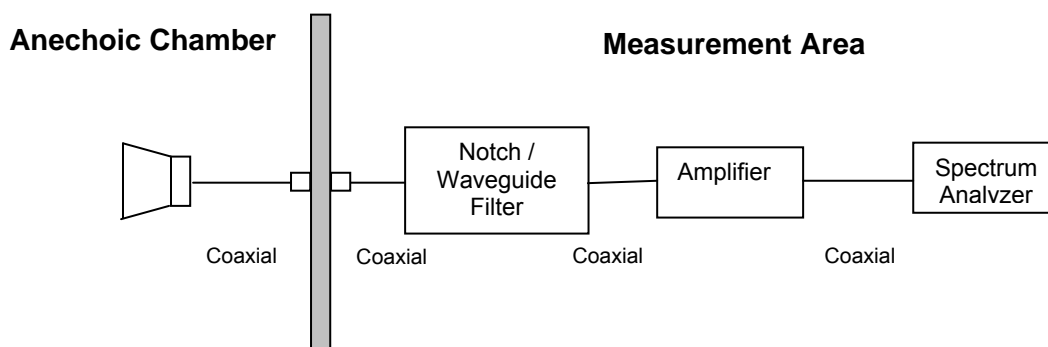

Measurement set up for Radiated Emission Test



Title: WhereTrack WTK-5000
To: FCC 47 CFR Part 15.247 & IC RSS-210
Serial #: ETSD15-A2 Rev A
Issue Date: 6th February '09
Page: 62 of 97

Field Strength Calculation

The field strength is calculated by adding the Antenna Factor and Cable Loss, and subtracting Amplifier Gain from the measured reading. All factors are included in the reported data.

$$FS = R + AF + CORR - FO$$

where: FS = Field Strength

R = Measured Spectrum analyzer Input Amplitude

AF = Antenna Factor

CORR = Correction Factor = CL – AG + NFL

CL = Cable Loss

AG = Amplifier Gain

FO = Distance Falloff Factor

NFL = Notch Filter Loss or Waveguide Loss

For example:

Given receiver input reading of 51.5 dB μ V; Antenna Factor of 8.5 dB; Cable Loss of 1.3 dB; Falloff Factor of 0 dB, an Amplifier Gain of 26 dB and Notch Filter Loss of 1 dB. The Field Strength of the measured emission is:

$$FS = 51.5 + 8.5 + 1.3 - 26.0 + 1 = 36.3 \text{ dB}\mu\text{V/m}$$

Conversion between dB μ V/m (or dB μ V) and μ V/m (or μ V) are done as:

$$\text{Level (dB}\mu\text{V/m)} = 20 * \text{Log (level (\mu V/m))}$$

$$40 \text{ dB}\mu\text{V/m} = 100 \mu\text{V/m}$$

$$48 \text{ dB}\mu\text{V/m} = 250 \mu\text{V/m}$$

During the radiated emission test a linear power supply was used to power the device under test. Voltage delivered to the device was +12 Vdc.

This test report may be reproduced in full only. The document may only be updated by MiCOM Labs personnel. Any changes will be noted in the Document History section of the report.



Title: WhereTrack WTK-5000
To: FCC 47 CFR Part 15.247 & IC RSS-210
Serial #: ETSD15-A2 Rev A
Issue Date: 6th February '09
Page: 63 of 97

802.11b Channel 2412 MHz Antenna Gain 5 dBi

TABLE OF RESULTS

Frequency MHz	Raw dBuV	Cable Loss	AF dB	Level dBuV	Measurement Type	Pol	Hgt cm	Azt Deg	Limit dBuV	Margin dB	Pass /Fail	Comments
2414.558	54.11	22.96	32.35	109.43	Peak [Scan]	H	N/A	N/A	N/A	N/A	N/A	Pk Emission
2412	Power Setting = Maximum			51.05	Peak Max	V	--	--	74	-22.95	Pass	Band-Edge
2412				38.79	Average Max	V	--	--	54	-15.21	Pass	Band-Edge
3180.361	56.02	3.46	-10.99	48.48	Peak Max	H	103	260	89.43	-40.95	Pass	NRB

Pk Emission – Peak Emission
 Band-edge – Restricted Bands
 RB – Restricted Band
 NRB – Non-Restricted Band

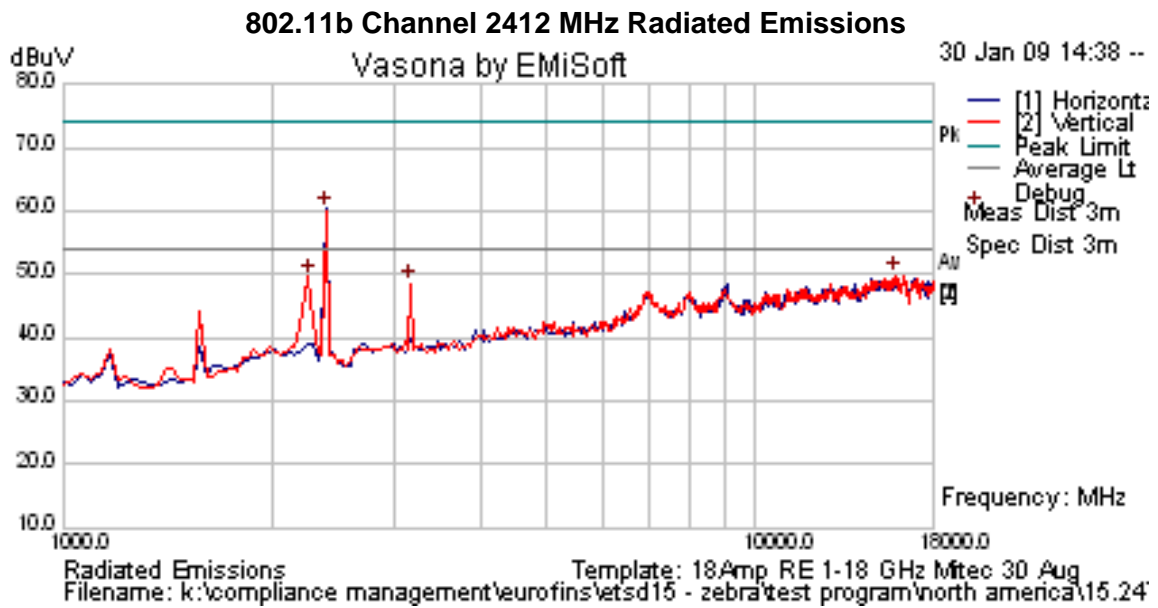

This test report may be reproduced in full only. The document may only be updated by MiCOM Labs personnel. Any changes will be noted in the Document History section of the report.



Title: WhereTrack WTK-5000
To: FCC 47 CFR Part 15.247 & IC RSS-210
Serial #: ETSD15-A2 Rev A
Issue Date: 6th February '09
Page: 64 of 97

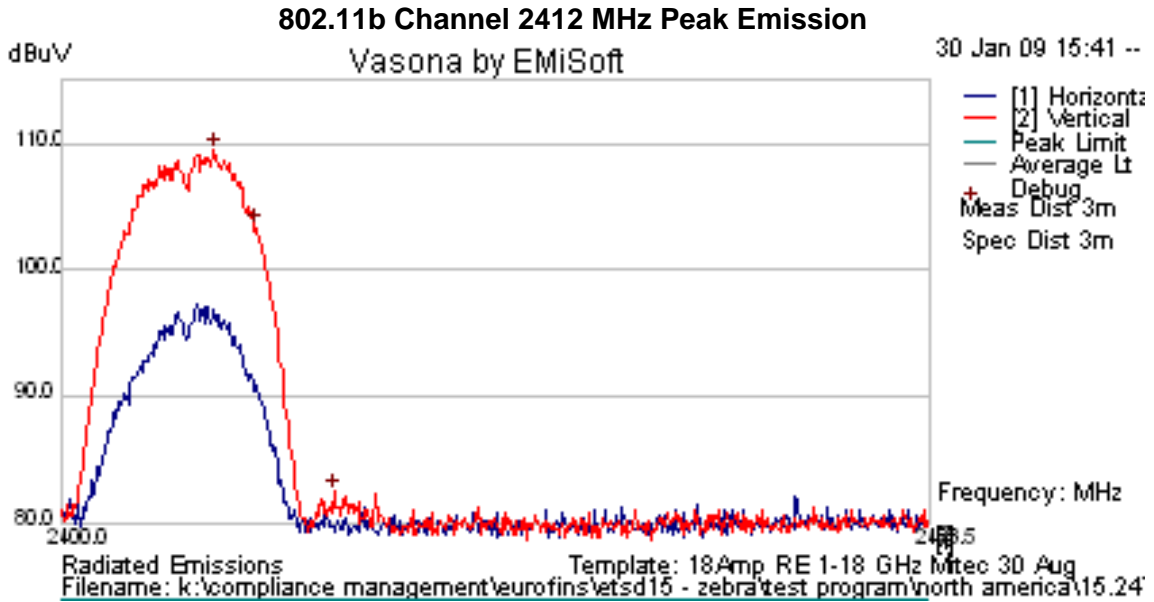

This test report may be reproduced in full only. The document may only be updated by MiCOM Labs personnel. Any changes will be noted in the Document History section of the report.



Title: WhereTrack WTK-5000
To: FCC 47 CFR Part 15.247 & IC RSS-210
Serial #: ETSD15-A2 Rev A
Issue Date: 6th February '09
Page: 65 of 97

802.11b Channel 2412 MHz Band-Edge

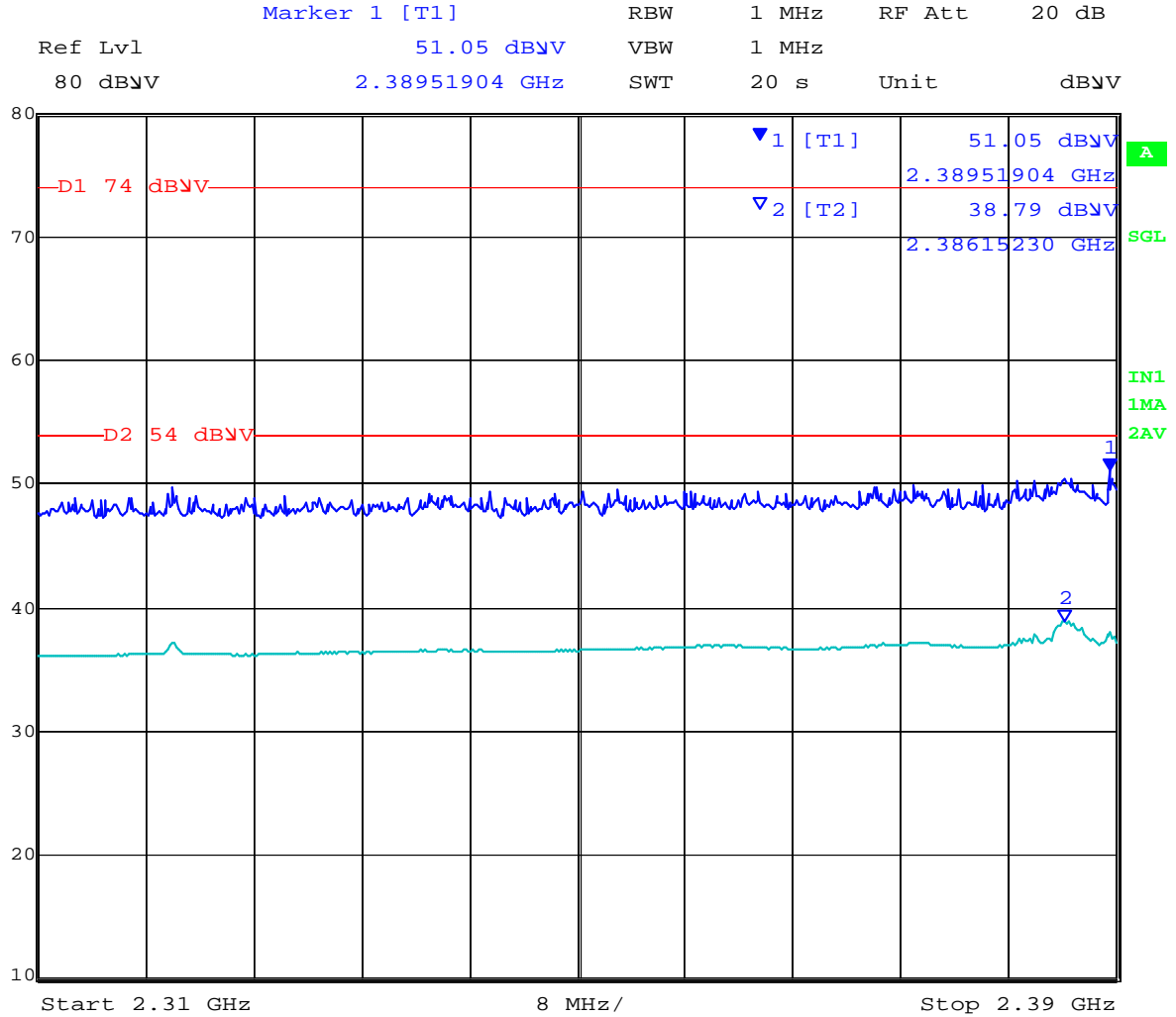

Date: 30.JAN.2009 15:37:48

This test report may be reproduced in full only. The document may only be updated by MiCOM Labs personnel. Any changes will be noted in the Document History section of the report.



Title: WhereTrack WTK-5000
To: FCC 47 CFR Part 15.247 & IC RSS-210
Serial #: ETSD15-A2 Rev A
Issue Date: 6th February '09
Page: 66 of 97

802.11b Channel 2437 MHz Antenna Gain 5 dBi

Power Setting = Maximum

TABLE OF RESULTS

Frequency MHz	Raw dBuV	Cable Loss	AF dB	Level dBuV	Measurement Type	Pol	Hgt cm	Azt Deg	Limit dBuV	Margin dB	Pass /Fail	Comments
2436.144	53.72	22.97	32.37	109.05	Peak [Scan]	H	N/A	N/A	N/A	N/A	N/A	Pk Emission
3180.361	56.95	3.46	-10.99	49.42	Peak Max	H	103	260	89.05	-39.63	Pass	NRB

Pk Emission – Peak Emission
 RB – Restricted Band
 NRB – Non-Restricted Band

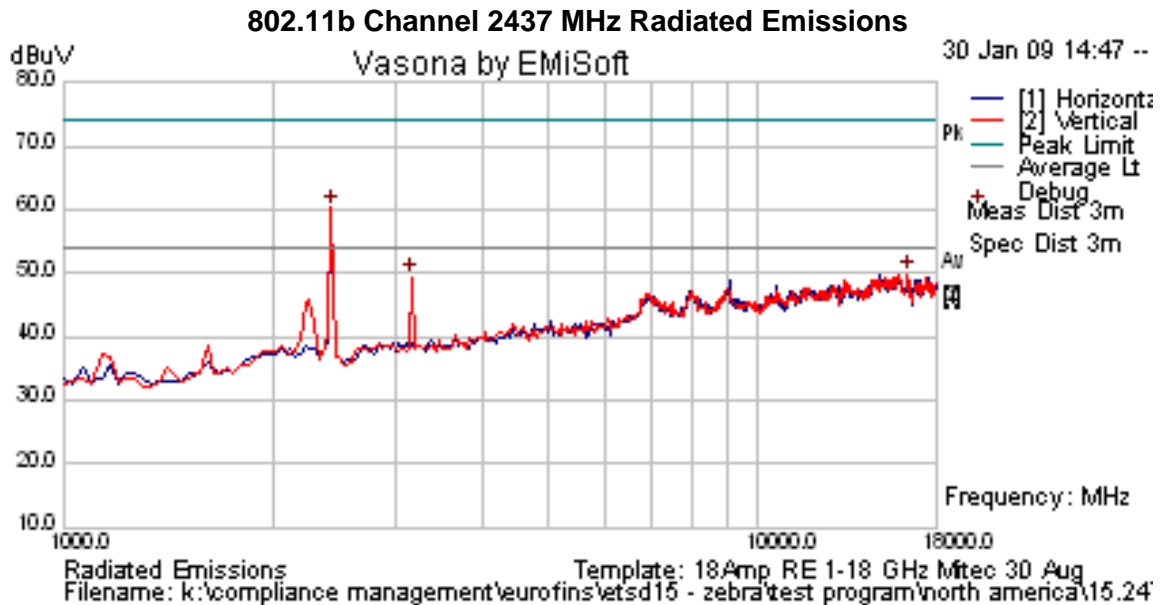

This test report may be reproduced in full only. The document may only be updated by MiCOM Labs personnel. Any changes will be noted in the Document History section of the report.



Title: WhereTrack WTK-5000
To: FCC 47 CFR Part 15.247 & IC RSS-210
Serial #: ETSD15-A2 Rev A
Issue Date: 6th February '09
Page: 67 of 97

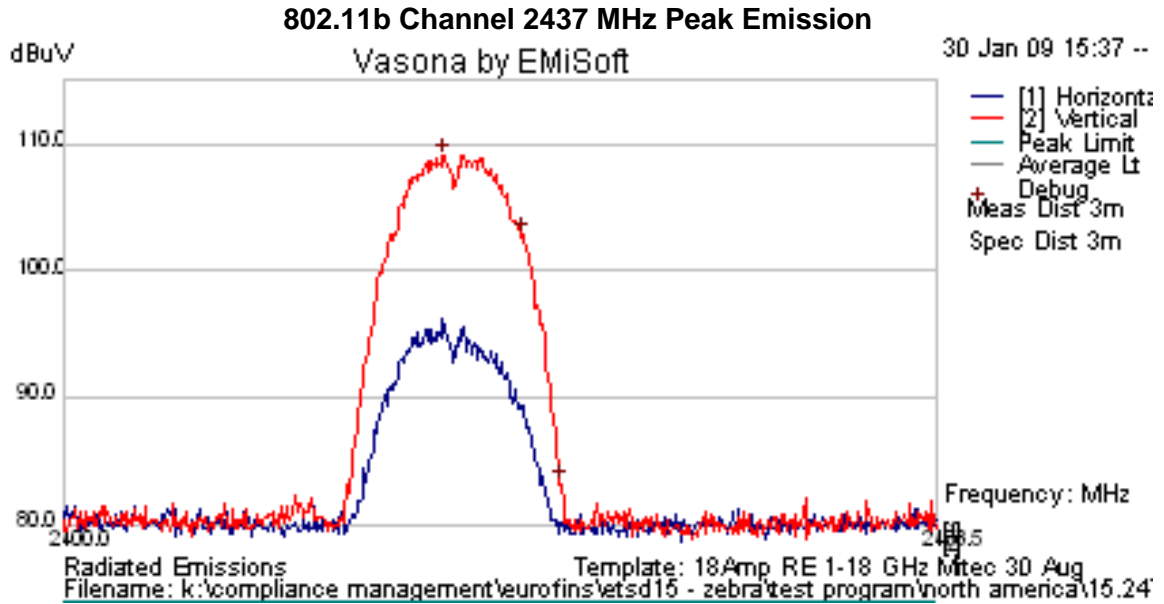

This test report may be reproduced in full only. The document may only be updated by MiCOM Labs personnel. Any changes will be noted in the Document History section of the report.



Title: WhereTrack WTK-5000
To: FCC 47 CFR Part 15.247 & IC RSS-210
Serial #: ETSD15-A2 Rev A
Issue Date: 6th February '09
Page: 68 of 97

802.11b Channel 2462 MHz Antenna Gain 5 dBi

TABLE OF RESULTS

Frequency MHz	Raw dBuV	Cable Loss	AF dB	Level dBuV	Measurement Type	Pol	Hgt cm	Azt Deg	Limit dBuV	Margin dB	Pass /Fail	Comments
2463.085	53.93	22.98	32.38	109.29	Peak [Scan]	H	N/A	N/A	N/A	N/A	N/A	Pk Emission
2489.51804	Power Setting = Maximum			50.21	Peak Max	V	--	--	74	-23.79	Pass	Band-Edge
2487.66633	Power Setting = Maximum			37.52	Average Max	V	--	--	54	-16.48	Pass	Band-Edge

Pk Emission – Peak Emission
 Band-edge – Restricted Bands
 RB – Restricted Band
 NRB – Non-Restricted Band

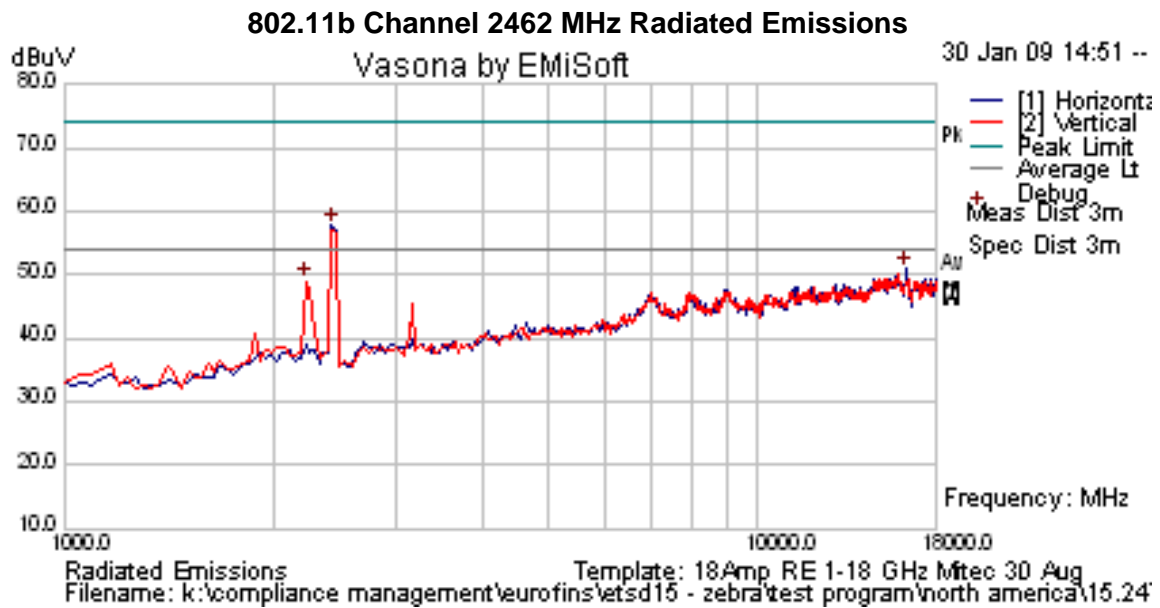

This test report may be reproduced in full only. The document may only be updated by MiCOM Labs personnel. Any changes will be noted in the Document History section of the report.



Title: WhereTrack WTK-5000
To: FCC 47 CFR Part 15.247 & IC RSS-210
Serial #: ETSD15-A2 Rev A
Issue Date: 6th February '09
Page: 69 of 97

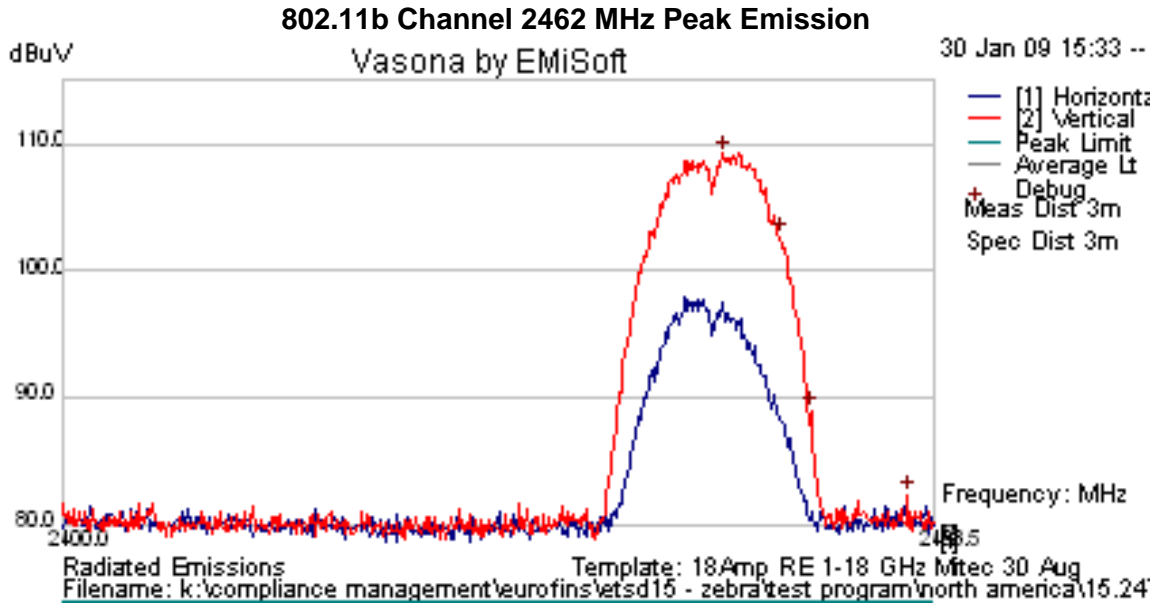

This test report may be reproduced in full only. The document may only be updated by MiCOM Labs personnel. Any changes will be noted in the Document History section of the report.



Title: WhereTrack WTK-5000
To: FCC 47 CFR Part 15.247 & IC RSS-210
Serial #: ETSD15-A2 Rev A
Issue Date: 6th February '09
Page: 70 of 97

802.11b Channel 2462 MHz Band-Edge

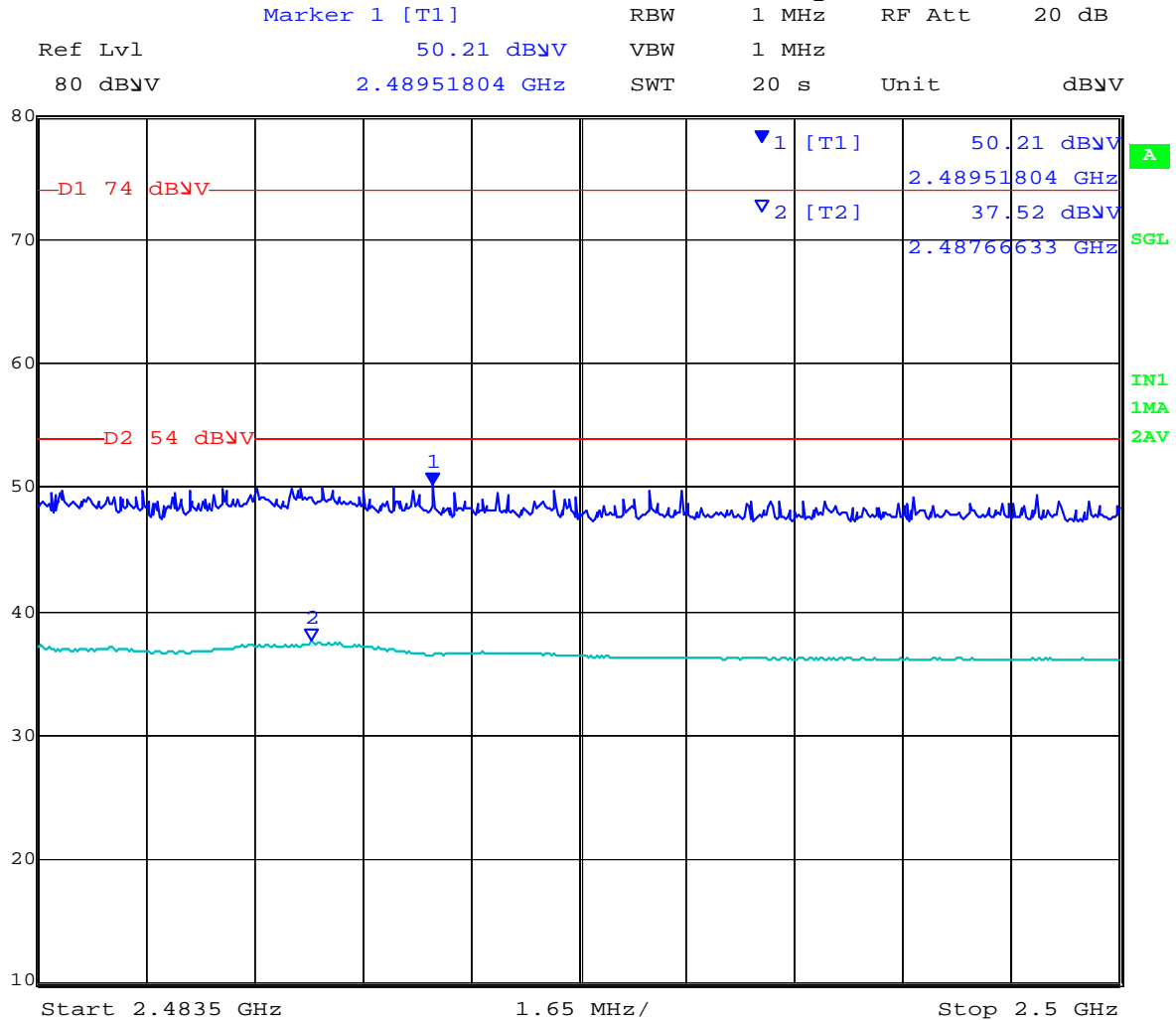

Date: 30.JAN.2009 15:59:35

This test report may be reproduced in full only. The document may only be updated by MiCOM Labs personnel. Any changes will be noted in the Document History section of the report.



802.11g Channel 2412 MHz Antenna Gain 5 dBi

TABLE OF RESULTS

Frequency MHz	Raw dBuV	Cable Loss	AF dB	Level dBuV	Measurement Type	Pol	Hgt cm	Azt Deg	Limit dBuV	Margin dB	Pass /Fail	Comments
2418.239	55.19	22.96	32.36	110.5	Peak [Scan]	H	N/A	N/A	N/A	N/A	N/A	Pk Emission
2390.000	Power Setting = Maximum			60.84	Peak Max	V	--	--	74	-13.16	Pass	Band Edge
2390.000				42.52	Average Max	V	--	--	54	-11.48	Pass	Band Edge
3180.361	59.8	3.46	-10.99	52.27	Peak Max	H	103	260	90.50	-38.23	Pass	NRB

Pk Emission – Peak Emission
 Band-edge – Restricted Bands
 RB – Restricted Band
 NRB – Non-Restricted Band

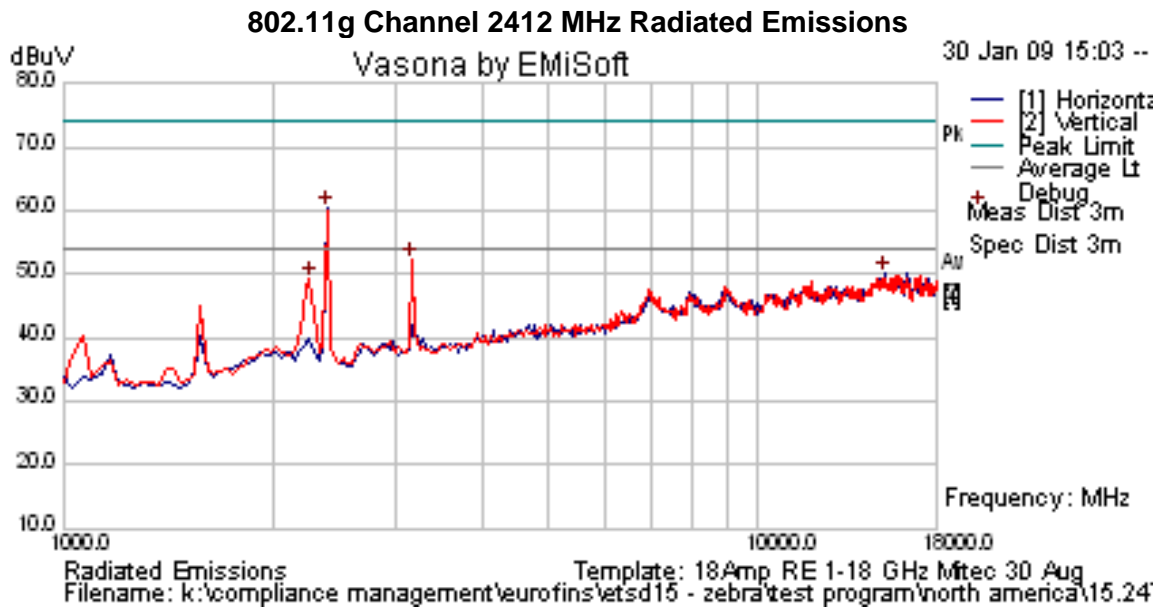

This test report may be reproduced in full only. The document may only be updated by MiCOM Labs personnel. Any changes will be noted in the Document History section of the report.



Title: WhereTrack WTK-5000
To: FCC 47 CFR Part 15.247 & IC RSS-210
Serial #: ETSD15-A2 Rev A
Issue Date: 6th February '09
Page: 72 of 97

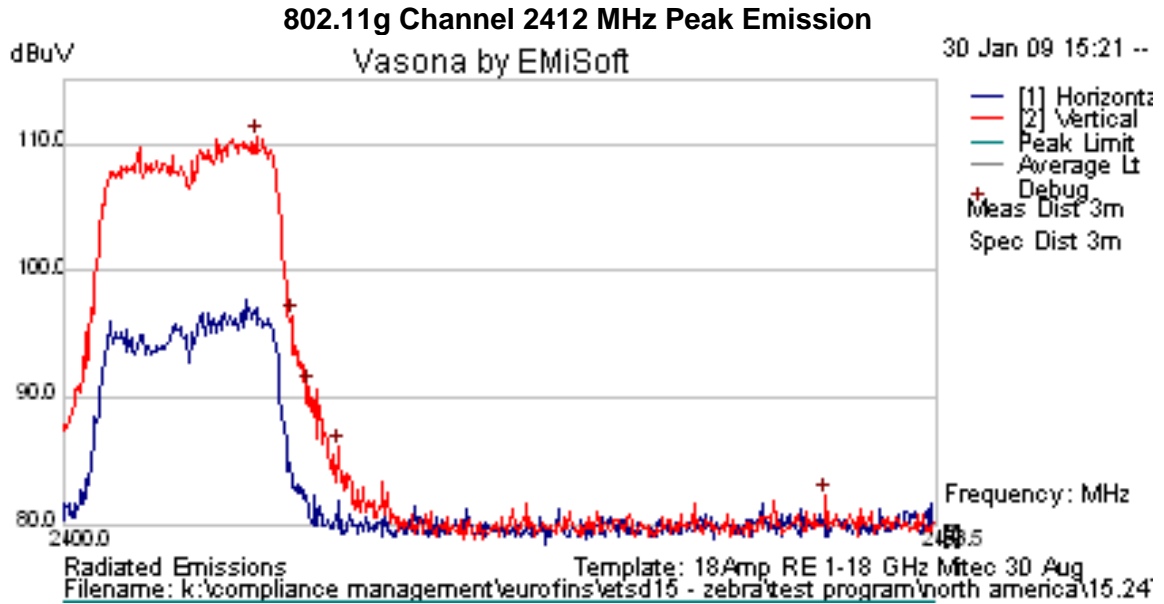

This test report may be reproduced in full only. The document may only be updated by MiCOM Labs personnel. Any changes will be noted in the Document History section of the report.



Title: WhereTrack WTK-5000
To: FCC 47 CFR Part 15.247 & IC RSS-210
Serial #: ETSD15-A2 Rev A
Issue Date: 6th February '09
Page: 73 of 97

802.11g Channel 2412 MHz Band-Edge

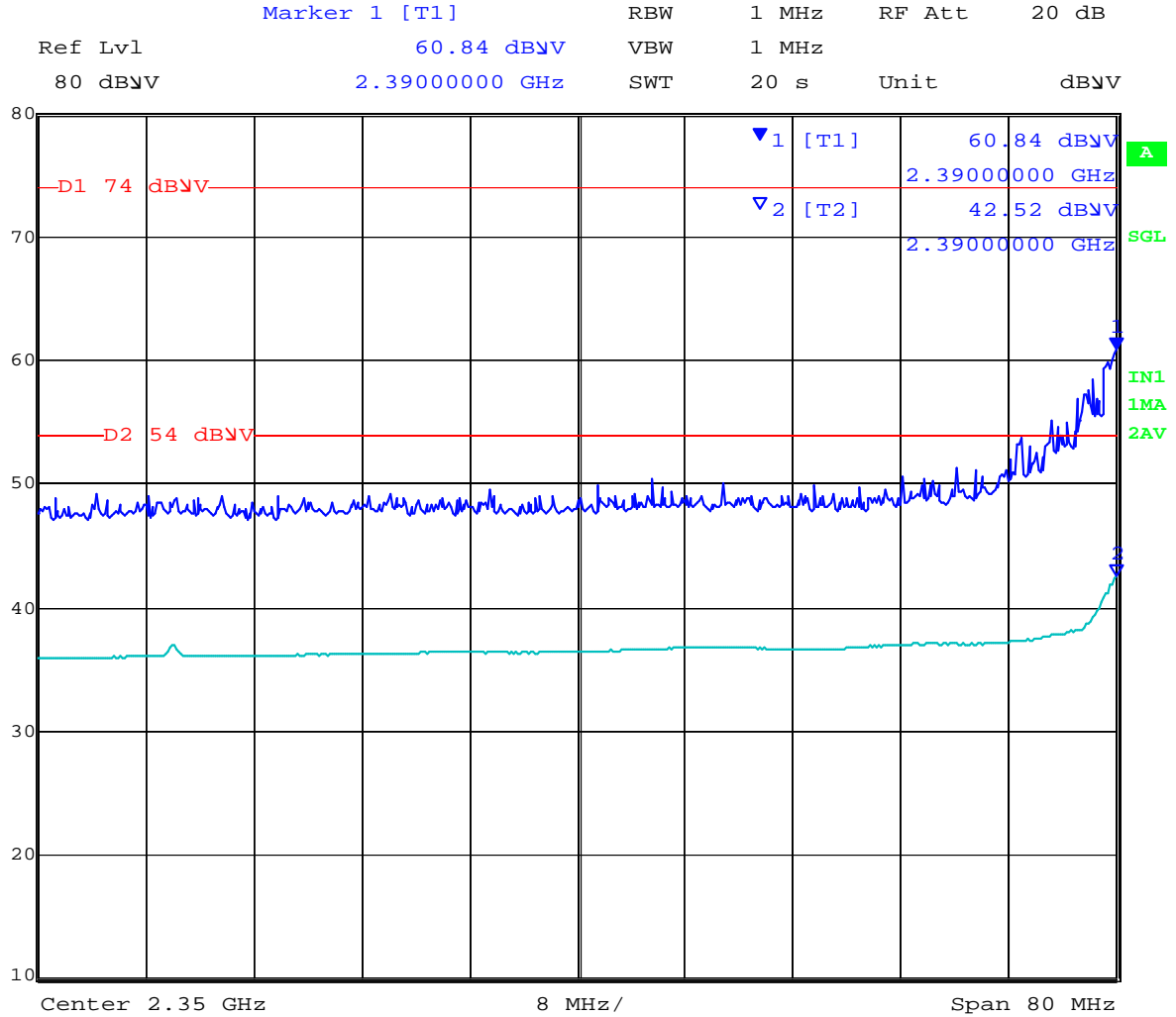

Date: 30.JAN.2009 15:48:11

This test report may be reproduced in full only. The document may only be updated by MiCOM Labs personnel. Any changes will be noted in the Document History section of the report.



Title: WhereTrack WTK-5000
To: FCC 47 CFR Part 15.247 & IC RSS-210
Serial #: ETSD15-A2 Rev A
Issue Date: 6th February '09
Page: 74 of 97

802.11g Channel 2437 MHz Antenna Gain 5 dBi

TABLE OF RESULTS

Frequency MHz	Raw dBuV	Cable Loss	AF dB	Level dBuV	Measurement Type	Pol	Hgt cm	Azt Deg	Limit dBuV	Margin dB	Pass /Fail	Comments
2443.005	57.24	22.97	32.37	112.58	Peak [Scan]	H	N/A	N/A	N/A	N/A	N/A	Pk Emission
3180.361	57.92	3.46	-10.99	50.39	Peak Max	H	103	260	92.58	-42.19	Pass	RB

Pk Emission – Peak Emission
 Band-edge – Restricted Bands
 RB – Restricted Band
 NRB – Non-Restricted Band

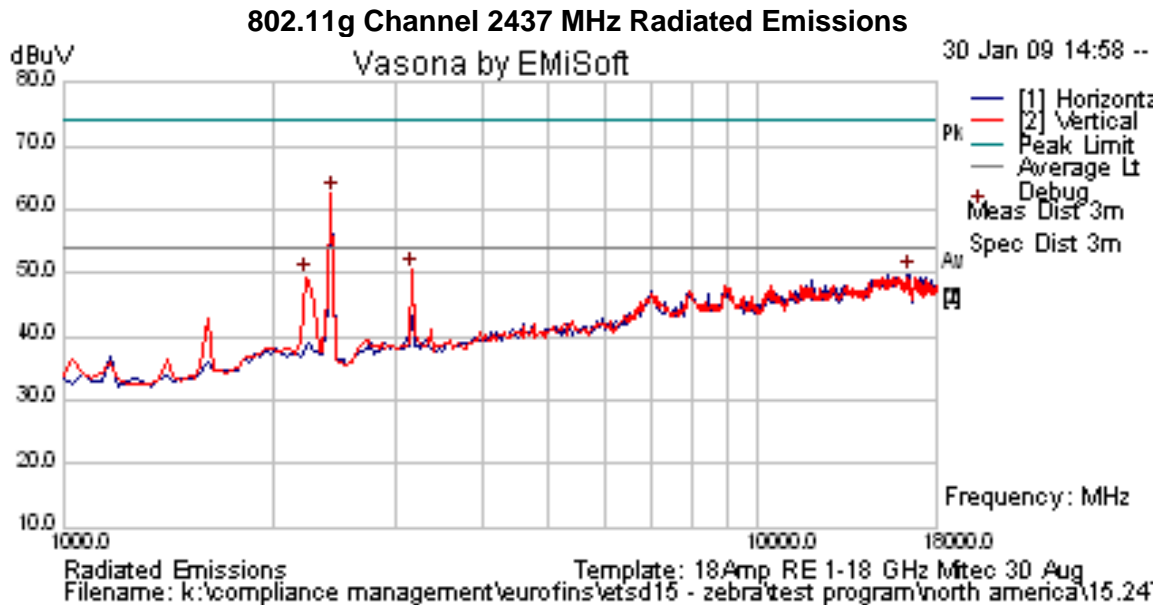

This test report may be reproduced in full only. The document may only be updated by MiCOM Labs personnel. Any changes will be noted in the Document History section of the report.



Title: WhereTrack WTK-5000
To: FCC 47 CFR Part 15.247 & IC RSS-210
Serial #: ETSD15-A2 Rev A
Issue Date: 6th February '09
Page: 75 of 97

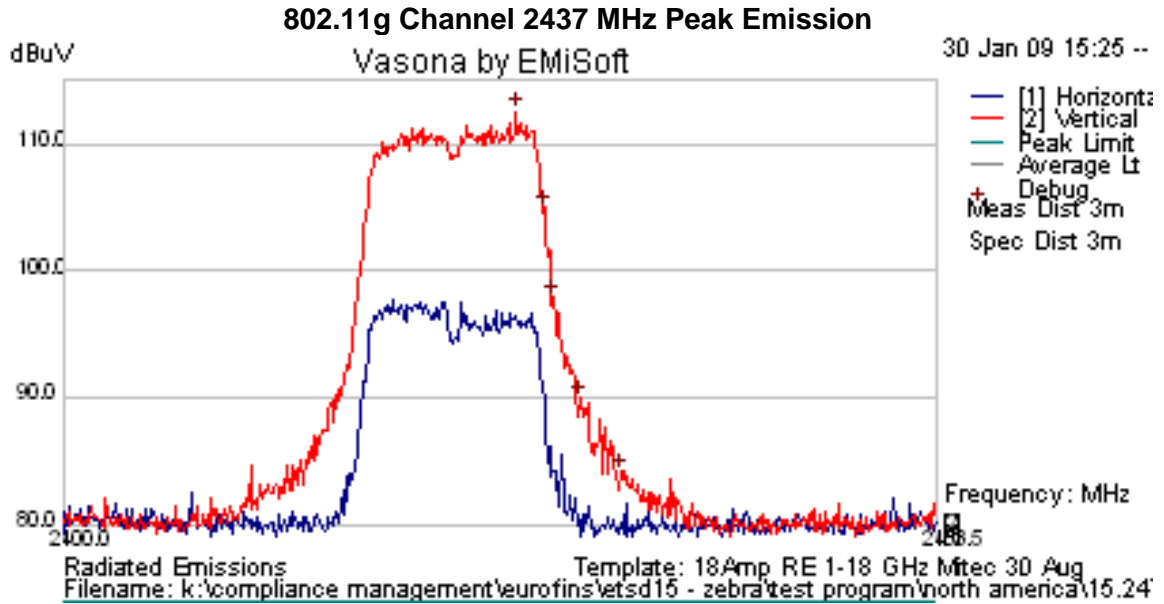

This test report may be reproduced in full only. The document may only be updated by MiCOM Labs personnel. Any changes will be noted in the Document History section of the report.



802.11g Channel 2462 MHz Antenna Gain 5 dBi

TABLE OF RESULTS

Frequency MHz	Raw dBuV	Cable Loss	AF dB	Level dBuV	Measurement Type	Pol	Hgt cm	Azt Deg	Limit dBuV	Margin dB	Pass /Fail	Comments
2466.432	53.59	22.98	32.38	108.96	Peak [Scan]	H	N/A	N/A	N/A	N/A	N/A	Pk Emission
2483.599	Power Setting = Maximum			57.28	Peak Max	V	--	--	74	-16.72	Pass	Band-Edge
2483.500	Power Setting = Maximum			39.79	Average Max	V	--	--	54	-14.21	Pass	Band-Edge
3180.361	60.07	3.46	-10.99	52.54	Peak Max	H	103	260	88.96	-36.42	Pass	NRB

Pk Emission – Peak Emission
 Band-edge – Restricted Bands
 RB – Restricted Band
 NRB – Non-Restricted Band

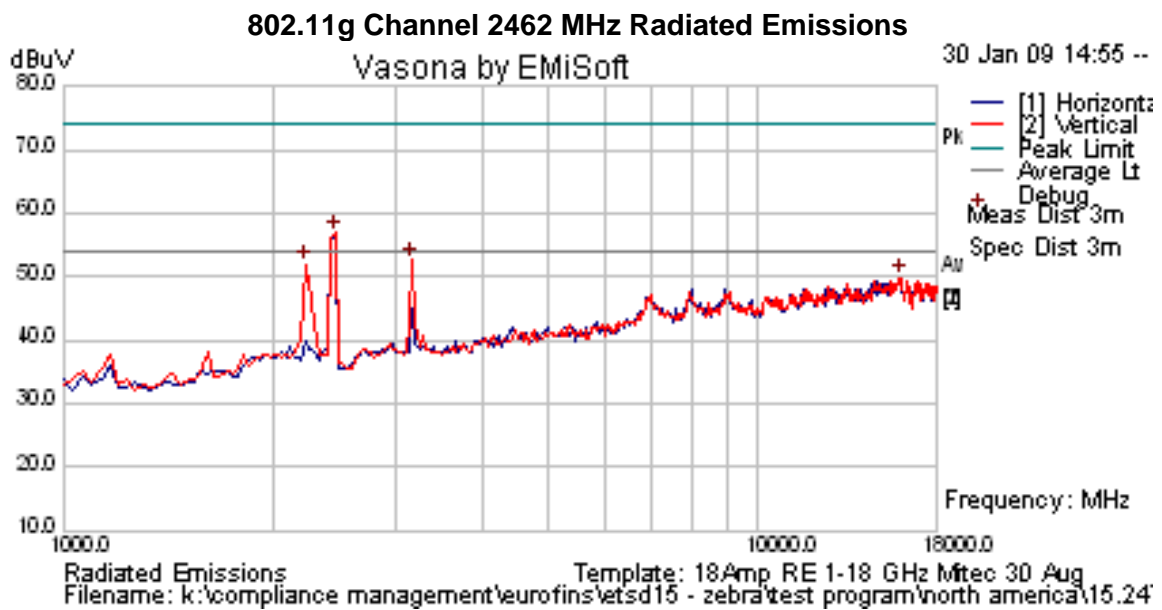

This test report may be reproduced in full only. The document may only be updated by MiCOM Labs personnel. Any changes will be noted in the Document History section of the report.



Title: WhereTrack WTK-5000
To: FCC 47 CFR Part 15.247 & IC RSS-210
Serial #: ETSD15-A2 Rev A
Issue Date: 6th February '09
Page: 77 of 97

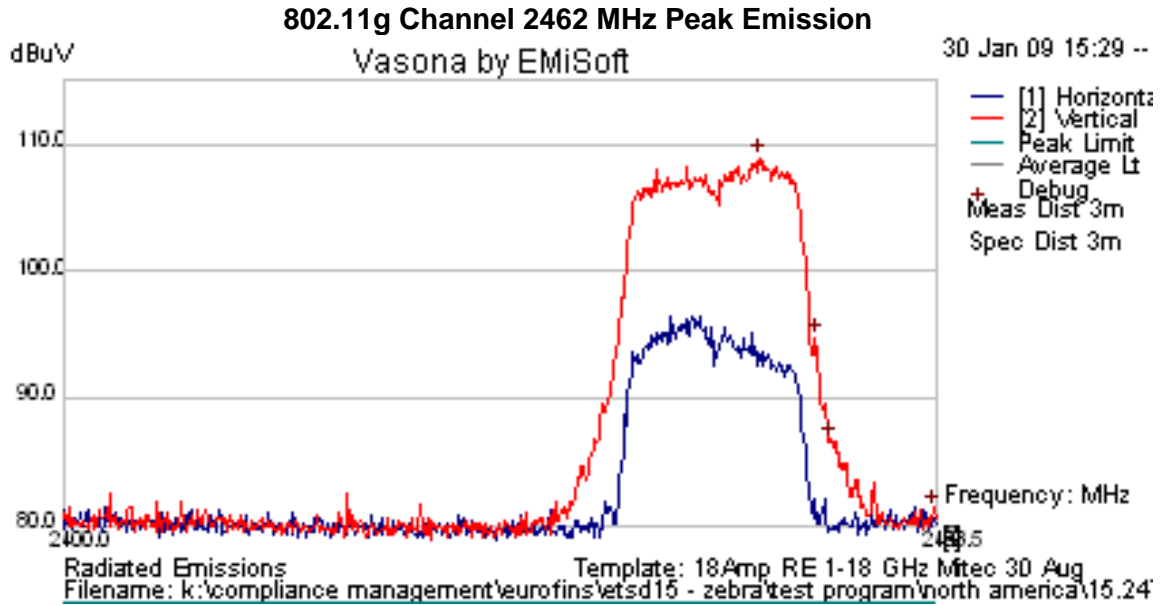

This test report may be reproduced in full only. The document may only be updated by MiCOM Labs personnel. Any changes will be noted in the Document History section of the report.



Title: WhereTrack WTK-5000
To: FCC 47 CFR Part 15.247 & IC RSS-210
Serial #: ETSD15-A2 Rev A
Issue Date: 6th February '09
Page: 78 of 97

802.11g Channel 2462 MHz Band-Edge

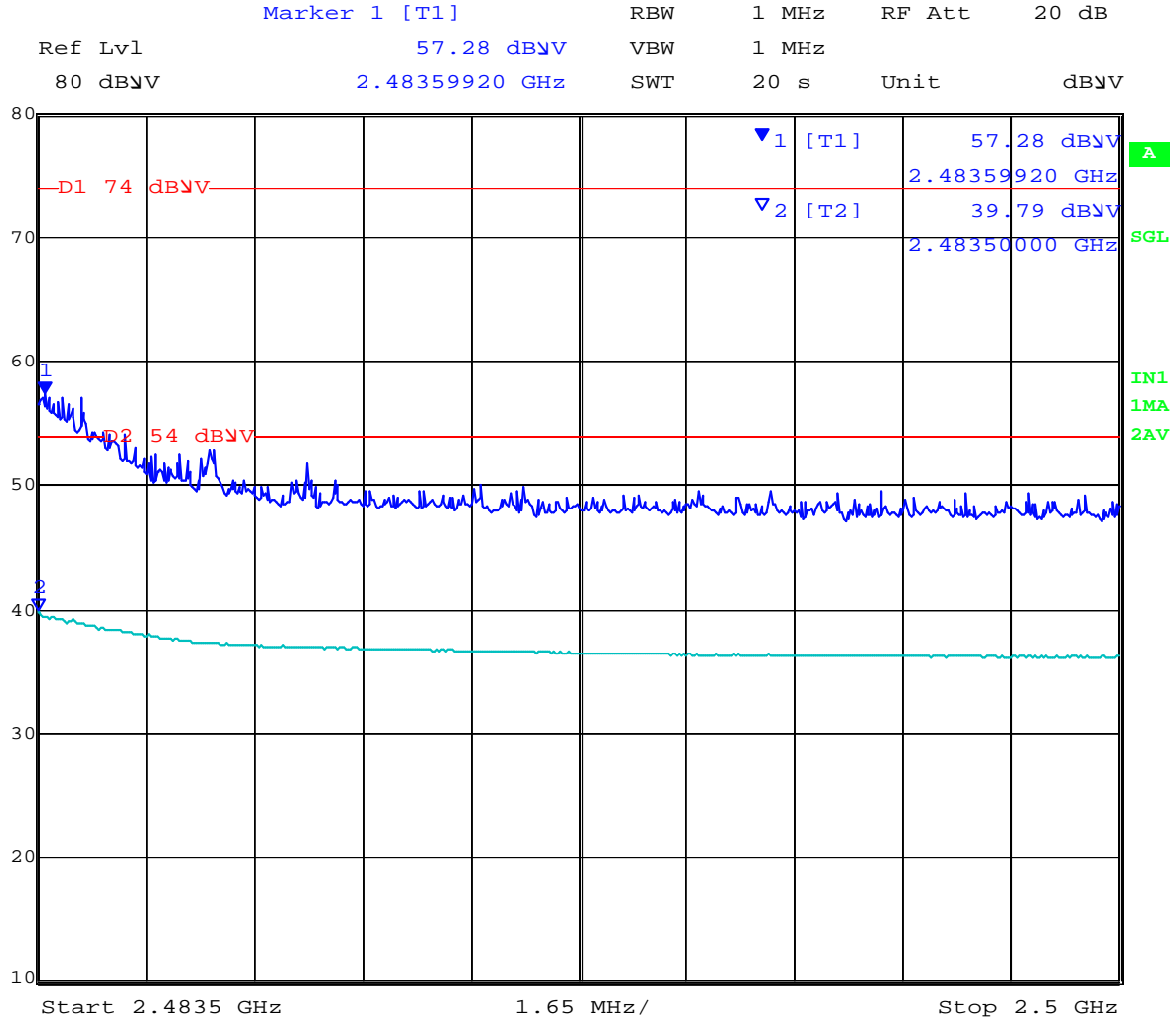

Date: 30.JAN.2009 15:55:57

This test report may be reproduced in full only. The document may only be updated by MiCOM Labs personnel. Any changes will be noted in the Document History section of the report.



Title: WhereTrack WTK-5000
To: FCC 47 CFR Part 15.247 & IC RSS-210
Serial #: ETSD15-A2 Rev A
Issue Date: 6th February '09
Page: 79 of 97

DSSS OPERATIONAL MODE

Measurements performed with EUT set for Pulsed Mode

TEST SETUP 2,441.75 MHz, DSSS mode Software Power Setting = +20dBm

TABLE OF RESULTS – DSSS

Frequency MHz	Raw dBuV	Cable Loss	AF dB	Level dBuV	Measurement Type	Pol	Hgt cm	Azt Deg	Limit dBuV	Margin dB	Pass /Fail	Comments
2440.175	53.93	22.98	32.38	111.36	Peak [Scan]	H	N/A	N/A	N/A	N/A	N/A	Pk Emission
2390.000	Power Setting = Maximum			59.21	Peak Max	V	--	--	74	-14.79	Pass	Band-Edge
2390.000	Power Setting = Maximum			53.22	Average Max	V	--	--	54	-0.78	Pass	Band-Edge
2483.500	Power Setting = Maximum			60.10	Peak Max	V	--	--	74	-13.90	Pass	Band-Edge
2483.500	Power Setting = Maximum			53.91	Average Max	V	--	--	54	-0.09	Pass	Band-Edge

Pk Emission – Peak Emission
 Band-edge – Restricted Bands
 RB – Restricted Band
 NRB – Non-Restricted Band

The emission breaking the Average limit line at 2441.75 MHz is the fundamental.

2441.75 MHz DSSS Configuration Spurious Emissions >1GHz

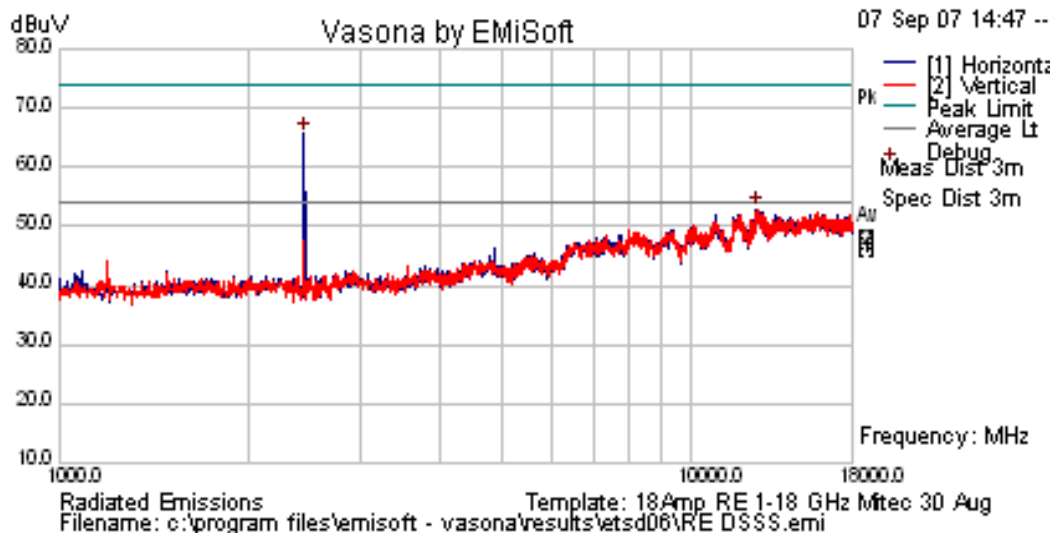

This test report may be reproduced in full only. The document may only be updated by MiCOM Labs personnel. Any changes will be noted in the Document History section of the report.



Title: WhereTrack WTK-5000
To: FCC 47 CFR Part 15.247 & IC RSS-210
Serial #: ETSD15-A2 Rev A
Issue Date: 6th February '09
Page: 80 of 97

Specification Limits

FCC §15.247(d) and RSS-210 §A8.5 In any 100 kHz bandwidth outside the frequency band in which the spread spectrum or digitally modulated intentional radiator is operating, the radio frequency power that is produced by the intentional radiator shall be at least 20 dB below that in the 100 kHz bandwidth within the band that contains the highest level of the desired power, based on either an RF conducted or radiated measurement, provided the transmitter demonstrates compliance with the peak conducted power limits.

FCC §15.247(d)

If the transmitter complies with the conducted power limits based on the use of RMS averaging over a time interval, as permitted under paragraph (b)(3) of this section, the attenuation required under this paragraph shall be 30 dB instead of 20 dB. Attenuation below the general limits specified §15.209(a) is not required. In addition, radiated emissions which fall in the restricted bands, as defined in Section §15.205(a), must also comply with the radiated emission limits specified in Section 15.209(a) (see Section 15.205(a)).

IC RSS-210 §A8.5 If the transmitter complies with the conducted power limits based on the use of RMS averaging over a time interval, as permitted under section A8.4(4), the attenuation required shall be 30 dB instead of 20 dB. Attenuation below the general limits specified in Tables 2 and 3 is not required. In addition, radiated emissions which fall in the restricted bands of Table 1 must also comply with the radiated emission limits specified in Tables 2 and 3.

IC RSS-Gen §4.7

The search for unwanted emissions shall be from the lowest frequency internally generated or used in the device (local oscillator, intermediate or carrier frequency), or from 30 MHz, whichever is the lowest frequency, to the 5th harmonic of the highest frequency generated without exceeding 40 GHz.

FCC §15.205 (a) Except as shown in paragraph (d) of 15.205 (a), only spurious emissions are permitted in any of the frequency bands listed.

FCC §15.205 (a) Except as shown in paragraphs (d) and (e) of this section, the field strength of emissions appearing within these frequency bands shall not exceed the limits shown in Section §15.209. At frequencies equal to or less than 1000 MHz, compliance with the limits in Section 15.209 shall be demonstrated using measurement instrumentation employing a CISPR quasi-peak detector. Above 1000 MHz, compliance with the emission limits in Section 15.209 shall be demonstrated based on the average value of the measured emissions. The provisions in Section 15.35 apply to these measurements.

FCC §15.209 (a) Except as provided elsewhere in this subpart, the emissions from an intentional radiator shall not exceed the field strength levels specified in the following table.

This test report may be reproduced in full only. The document may only be updated by MiCOM Labs personnel. Any changes will be noted in the Document History section of the report.



Title: WhereTrack WTK-5000
To: FCC 47 CFR Part 15.247 & IC RSS-210
Serial #: ETSD15-A2 Rev A
Issue Date: 6th February '09
Page: 81 of 97

Frequency (MHz)	Field Strength ($\mu\text{V/m}$)	Field Strength ($\text{dB}\mu\text{V/m}$)	Measurement Distance (meters)
30-88	100	40.0	3
88-216	150	43.5	3
216-960	200	46.0	3
Above 960	500	54.0	3

Laboratory Measurement Uncertainty for Radiated Emissions

Measurement uncertainty	+5.6/ -4.5 dB
-------------------------	---------------

Traceability

Method	Test Equipment Used
Measurements were made per work instruction WI-03 'Measurement of Radiated Emissions'	0088, 0158, 0134, 0304, 0311, 0315, 0310, 0312

This test report may be reproduced in full only. The document may only be updated by MiCOM Labs personnel. Any changes will be noted in the Document History section of the report.

5.1.6.2. Receiver Radiated Spurious Emissions (above 1 GHz)

Industry Canada RSS-Gen §4.8, §6

Test Procedure

Radiated emissions above 1 GHz are measured in the anechoic chamber at a 3-meter distance on every azimuth in both horizontal and vertical polarities. The emissions are recorded and maximized as a function of azimuth by rotation through 360° with a spectrum analyzer in peak hold mode. Depending on the frequency band spanned a notch filter and waveguide filter was used to remove the fundamental frequency. The highest emissions relative to the limit are listed for each frequency spanned.

All measurements on any frequency or frequencies over 1 MHz are based on the use of measurement instrumentation employing an average detector function. All measurements above 1 GHz were performed using a minimum resolution bandwidth of 1 MHz.

Test Measurement Set up

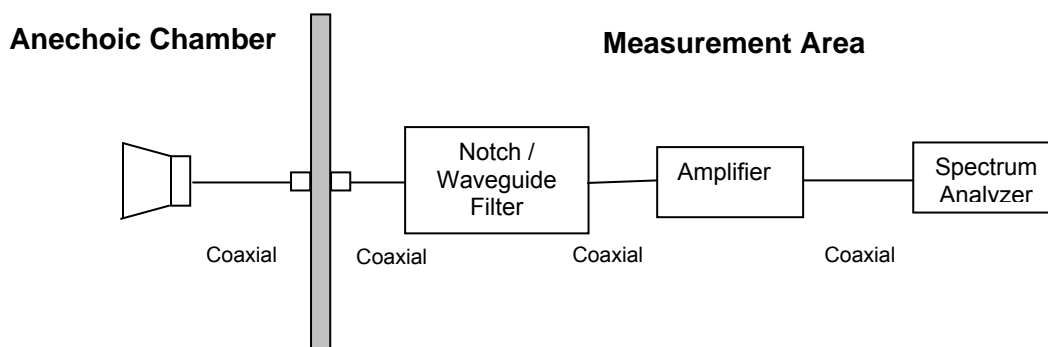

Measurement set up for Radiated Emission Test

Field Strength Calculation

The field strength is calculated by adding the Antenna Factor and Cable Loss, and subtracting Amplifier Gain from the measured reading. All factors are included in the reported data.

$$FS = R + AF + CORR - FO$$

where: FS = Field Strength

R = Measured Spectrum analyzer Input Amplitude

AF = Antenna Factor

CORR = Correction Factor = CL – AG + NFL

CL = Cable Loss

AG = Amplifier Gain

FO = Distance Falloff Factor

NFL = Notch Filter Loss or Waveguide Loss



Title: WhereTrack WTK-5000
To: FCC 47 CFR Part 15.247 & IC RSS-210
Serial #: ETSD15-A2 Rev A
Issue Date: 6th February '09
Page: 83 of 97

For example:

Given receiver input reading of 51.5 dB μ V; Antenna Factor of 8.5 dB; Cable Loss of 1.3 dB; Falloff Factor of 0 dB, an Amplifier Gain of 26 dB and Notch Filter Loss of 1 dB. The Field Strength of the measured emission is:

$$FS = 51.5 + 8.5 + 1.3 - 26.0 + 1 = 36.3 \text{ dB}\mu\text{V/m}$$

Conversion between dB μ V/m (or dB μ V) and μ V/m (or μ V) are done as:

$$\text{Level (dB}\mu\text{V/m)} = 20 * \text{Log (level (\mu\text{V/m}))}$$

$$40 \text{ dB}\mu\text{V/m} = 100 \mu\text{V/m}$$

$$48 \text{ dB}\mu\text{V/m} = 250 \mu\text{V/m}$$

During the radiated emission test a linear power supply was used to power the device under test. Voltage delivered to the device was +12 Vdc.

This test report may be reproduced in full only. The document may only be updated by MiCOM Labs personnel. Any changes will be noted in the Document History section of the report.



Receiver Radiated Spurious Emissions above 1 GHz

Receiver results cover all variants

TABLE OF RESULTS

802.11bg Channel 2437 MHz Antenna Gain 5 dBi

TABLE OF RESULTS

Frequency MHz	Raw dBuV	Cable Loss	AF dB	Level dBuV	Measurement Type	Pol	Hgt cm	Azt Deg	Limit dBuV	Margin dB	Pass /Fail	Comments
98.036	-52.93	4.14	-9.18	-57.97	Max Average	H	150	0	-57	-0.97	Pass	
500.421	-65.06	6.00	0.09	-58.97	Max Average	H	150	0	-57	-1.97	Pass	
105.812	-57.9	4.21	-7.09	-60.78	Max Average	H	150	0	-57	-3.78	Pass	
33.888	-71.43	3.46	-0.37	-68.34	Max Average	V	150	0	-57	-11.34	Pass	
249.659	-67.69	4.99	-6.22	-68.92	Max Average	V	150	0	-57	-11.92	Pass	
624.83	-77.62	6.47	1.76	-57.39	Max Average	H	150	0	-57	-12.39	Pass	

802.11bg Channel 2437 MHz Receiver Radiated Emissions

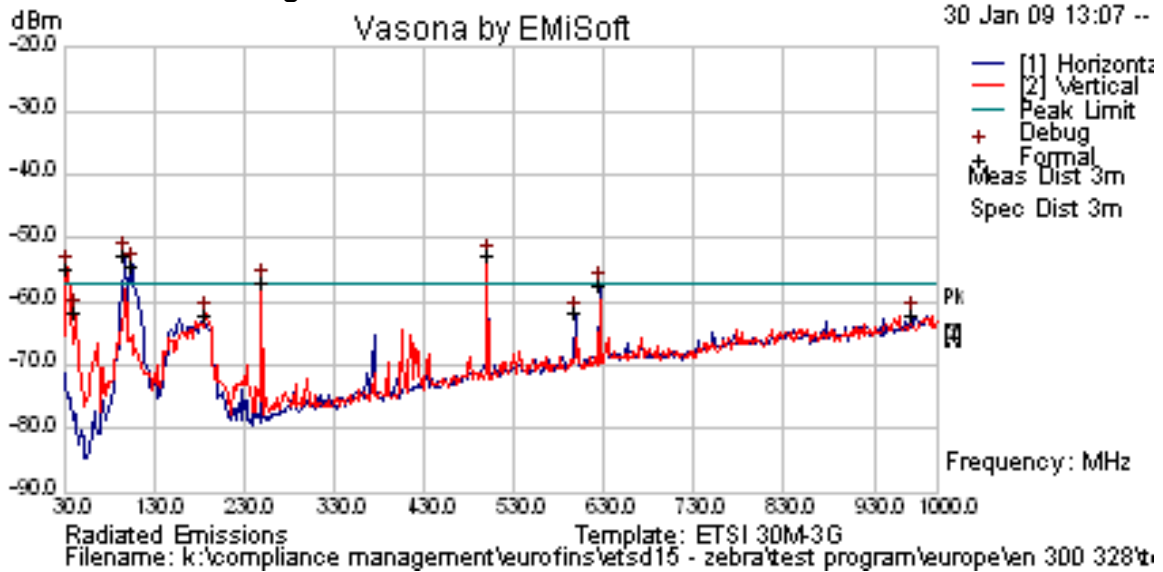

This test report may be reproduced in full only. The document may only be updated by MiCOM Labs personnel. Any changes will be noted in the Document History section of the report.



Title: WhereTrack WTK-5000
To: FCC 47 CFR Part 15.247 & IC RSS-210
Serial #: ETSD15-A2 Rev A
Issue Date: 6th February '09
Page: 85 of 97

Specification

Receiver Radiated Spurious Emissions

Industry Canada RSS-Gen §4.8,

The search for spurious emissions shall be from the lowest frequency internally generated or used in the receiver (e.g. local oscillator, intermediate or carrier frequency), or 30 MHz, whichever is the higher, to at least 3 times the highest tunable or local oscillator frequency, whichever is the higher, without exceeding 40 GHz.

RSS-Gen §6

The following receiver spurious emission limits shall be complied with;

- a. If a radiated measurement is made, all spurious emissions shall comply with the limits of Table 1.

Frequency (MHz)	Field Strength ($\mu\text{V/m}$)	Field Strength ($\text{dB}\mu\text{V/m}$)	Measurement Distance (meters)
30-88	100	40.0	3
88-216	150	43.5	3
216-960	200	46.0	3
Above 960	500	54.0	3

Laboratory Measurement Uncertainty for Radiated Emissions

Measurement uncertainty	+5.6/ -4.5 dB
-------------------------	---------------

Traceability

Method	Test Equipment Used
Measurements were made per work instruction WI-03 'Measurement of Radiated Emissions'	0088, 0158, 0134, 0304, 0311, 0315, 0310, 0312

This test report may be reproduced in full only. The document may only be updated by MiCOM Labs personnel. Any changes will be noted in the Document History section of the report.

5.1.6.3. Radiated Spurious Emissions (30M - 1GHz)

FCC, Part 15 Subpart C §15.205/ §15.209
Industry Canada RSS-210 §2.2

Test Procedure

Preliminary radiated emissions are measured in the anechoic chamber at a 3-meter distance on every azimuth in both horizontal and vertical polarity. The emissions are recorded with a spectrum analyzer in peak hold mode. Emissions closest to the limits are measured in the quasi-peak mode. Only the highest emissions relative to the limit are listed.

Test Measurement Set up

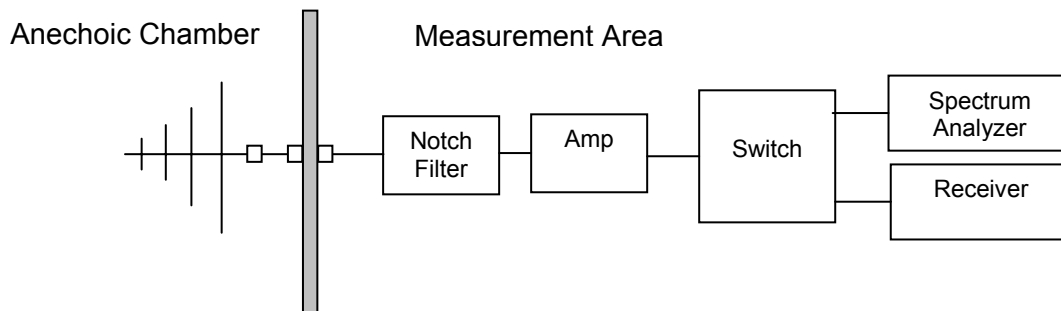

This test report may be reproduced in full only. The document may only be updated by MiCOM Labs personnel. Any changes will be noted in the Document History section of the report.



Title: WhereTrack WTK-5000
To: FCC 47 CFR Part 15.247 & IC RSS-210
Serial #: ETSD15-A2 Rev A
Issue Date: 6th February '09
Page: 87 of 97

Field Strength Calculation

The field strength is calculated by adding the Antenna Factor and Cable Loss, and subtracting Amplifier Gain from the measured reading. In this test facility, the Antenna Factor, Cable Loss, and Amplifier Gains are loaded into the Rohde & Schwarz Receiver and the corrected field strength can be read directly on the receiver.

where: $FS = R + AF + CORR$

FS = Field Strength
R = Measured Receiver Input Amplitude
AF = Antenna Factor
CORR = Correction Factor = CL – AG + NFL
CL = Cable Loss
AG = Amplifier Gain

For example:

Given a Receiver input reading of 51.5dB μ V; Antenna Factor of 8.5dB; Cable Loss of 1.3dB; Falloff Factor of 0dB, an Amplifier Gain of 26dB and Notch Filter Loss of 1dB. The Field Strength of the measured emission is:

$$FS = 51.5 + 8.5 + 1.3 - 26.0 + 1 = 36.3\text{dB}\mu\text{V/m}$$

Conversion between dB μ V/m (or dB μ V) and μ V/m (or μ V) are done as:

$$\text{Level (dB}\mu\text{V/m)} = 20 * \text{Log (level (\mu\text{V/m}))}$$

$$40 \text{ dB}\mu\text{V/m} = 100\mu\text{V/m}$$

$$48 \text{ dB}\mu\text{V/m} = 250\mu\text{V/m}$$

During the radiated emission test a linear power supply was used to power the device under test. Voltage delivered to the device was +12 Vdc.

Measurement Results for Spurious Emissions (30 MHz – 1 GHz)

Ambient conditions.

Temperature: 17 to 23 °C Relative humidity: 31 to 57 % Pressure: 999 to 1012 mbar

EUT parameters:

Frequency: 2412 MHz

Power Level: Maximum

This test report may be reproduced in full only. The document may only be updated by MiCOM Labs personnel. Any changes will be noted in the Document History section of the report.



TABLE OF RESULTS – +12 Vdc

Frequency MHz	Raw dBuV	Cable Loss	AF dB	Level dBuV	Measurement Type	Pol	Hgt cm	Azt Deg	Limit dBuV	Margin dB
39.459	57.53	3.56	-16.98	44.11	Quasi Max	V	98	180	50.5	-6.39
30.63	50.37	3.38	-10.12	43.63	Quasi Max	V	119	229	50.5	-6.87
500.01	53.82	6	-12.62	47.2	Quasi Max	H	181	125	57.5	-10.30
249.992	59.97	4.99	-18.92	46.04	Quasi Max	H	133	265	57.5	-11.46
56.003	57.56	3.79	-23.85	37.5	Quasi Max	V	114	354	50.5	-13.00
104.742	52.29	4.2	-19.60	36.88	Quasi Max	H	169	149	50.5	-13.62

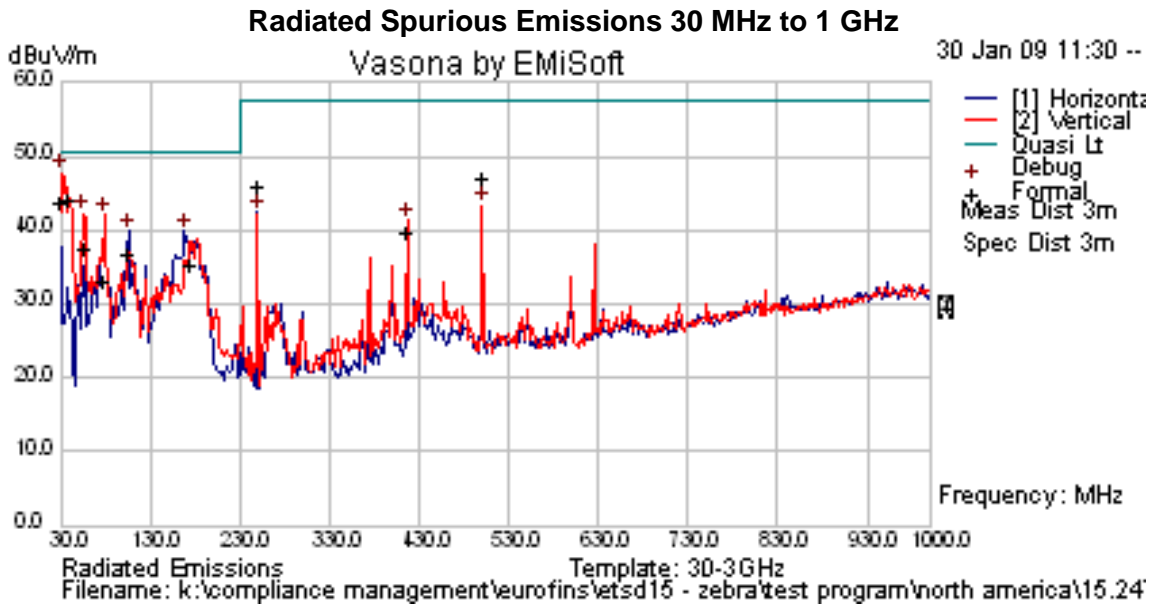

This test report may be reproduced in full only. The document may only be updated by MiCOM Labs personnel. Any changes will be noted in the Document History section of the report.



Title: WhereTrack WTK-5000
To: FCC 47 CFR Part 15.247 & IC RSS-210
Serial #: ETSD15-A2 Rev A
Issue Date: 6th February '09
Page: 89 of 97

Specification

Limits

§15.205 (a) Except as shown in paragraph (d) of 15.205 (a), only spurious emissions are permitted in any of the frequency bands listed.

§15.205 (a) Except as shown in paragraphs (d) and (e) of this section, the field strength of emissions appearing within these frequency bands shall not exceed the limits shown in Section §15.209. At frequencies equal to or less than 1000 MHz, compliance with the limits in Section 15.209 shall be demonstrated using measurement instrumentation employing a CISPR quasi-peak detector. Above 1000 MHz, compliance with the emission limits in Section 15.209 shall be demonstrated based on the average value of the measured emissions. The provisions in Section 15.35 apply to these measurements.

§15.209 (a) Except as provided elsewhere in this subpart, the emissions from an intentional radiator shall not exceed the field strength levels specified in the following table.

§15.209 (a) and RSS-Gen §2.2 Limit Matrix

Frequency(MHz)	Field Strength ($\mu\text{V}/\text{m}$)	Field Strength ($\text{dB}\mu\text{V}/\text{m}$)	Measurement Distance (meters)
30-88	100	40.0	3
88-216	150	43.5	3
216-960	200	46.0	3
Above 960	500	54.0	3

Laboratory Measurement Uncertainty for Radiated Emissions

Measurement uncertainty	+5.6/ -4.5 dB
-------------------------	---------------

Traceability

Method	Test Equipment Used
Measurements were made per work instruction WI-03 'Measurement of Radiated Emissions'	0088, 0158, 0134, 0304, 0311, 0315, 0310, 0312

This test report may be reproduced in full only. The document may only be updated by MiCOM Labs personnel. Any changes will be noted in the Document History section of the report.

5.1.7. AC Wireline Conducted Emissions (150 kHz – 30 MHz)

FCC, Part 15 Subpart C §15.207
Industry Canada RSS-Gen §7.2.2

Test Procedure

The EUT is configured in accordance with ANSI C63.4. The conducted emissions are measured in a shielded room with a spectrum analyzer in peak hold in the first instance. Emissions closest to the limit are measured in the quasi-peak mode (QP) with the tuned receiver using a bandwidth of 9 kHz. The emissions are maximized further by cable manipulation. The highest emissions relative to the limit are listed.

All six transmitters were operational and terminated in a 50Ω load.

Test Measurement Set up

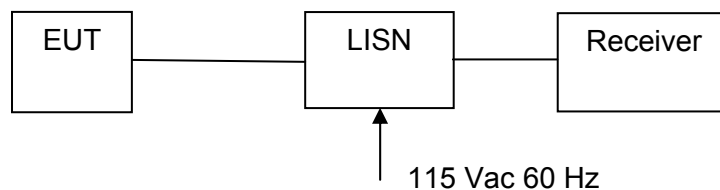

Measurement set up for AC Wireline Conducted Emissions Test

Measurement Results for AC Wireline Conducted Emissions (150 kHz – 30 MHz)

No test required the device was dc operated



Specification

Limit

§15.207 (a) Except as shown in paragraphs (b) and (c) of this section, for an intentional radiator that is designed to be connected to the public utility (AC) power line, the radio frequency voltage that is conducted back onto the AC power line on any frequency or frequencies within the band 150 kHz to 30 MHz shall not exceed the limits in the following table, as measured using a 50 $\mu\Omega$ line impedance stabilization network (LISN), see §15.207 (a) matrix below. Compliance with the provisions of this paragraph shall be based on the measurement of the radio frequency voltage between each power line and ground at the power terminal.

RSS-Gen §7.2.2

The radio frequency voltage that is conducted back into the AC power lines in the frequency range of 0.15 MHz to 30 MHz shall not exceed the limits shown in the table below. The tighter limit applies at the frequency range boundaries.

§15.207 (a) and **RSS-Gen §7.2.2** Limit Matrix

The lower limit applies at the boundary between frequency ranges

Frequency of Emission (MHz)	Conducted Limit (dB μ V)	
	Quasi-peak	Average
0.15-0.5	66 to 56*	56 to 46*
0.5-5	56	46
5-30	60	50

* Decreases with the logarithm of the frequency

Laboratory Measurement Uncertainty for Conducted Emissions

Measurement uncertainty	± 2.64 dB
-------------------------	---------------

Traceability

Method	Test Equipment Used
Measurements were made per work instruction WI-EMC-01 'Measurement of Conducted Emissions'	0158, 0184, 0193, 0190, 0293, 0307

This test report may be reproduced in full only. The document may only be updated by MiCOM Labs personnel. Any changes will be noted in the Document History section of the report.

6. PHOTOGRAPHS

6.1. Radiated Emissions \leq 1 GHz



This test report may be reproduced in full only. The document may only be updated by MiCOM Labs personnel. Any changes will be noted in the Document History section of the report.

6.2. Radiated Emissions ≥ 1 GHz

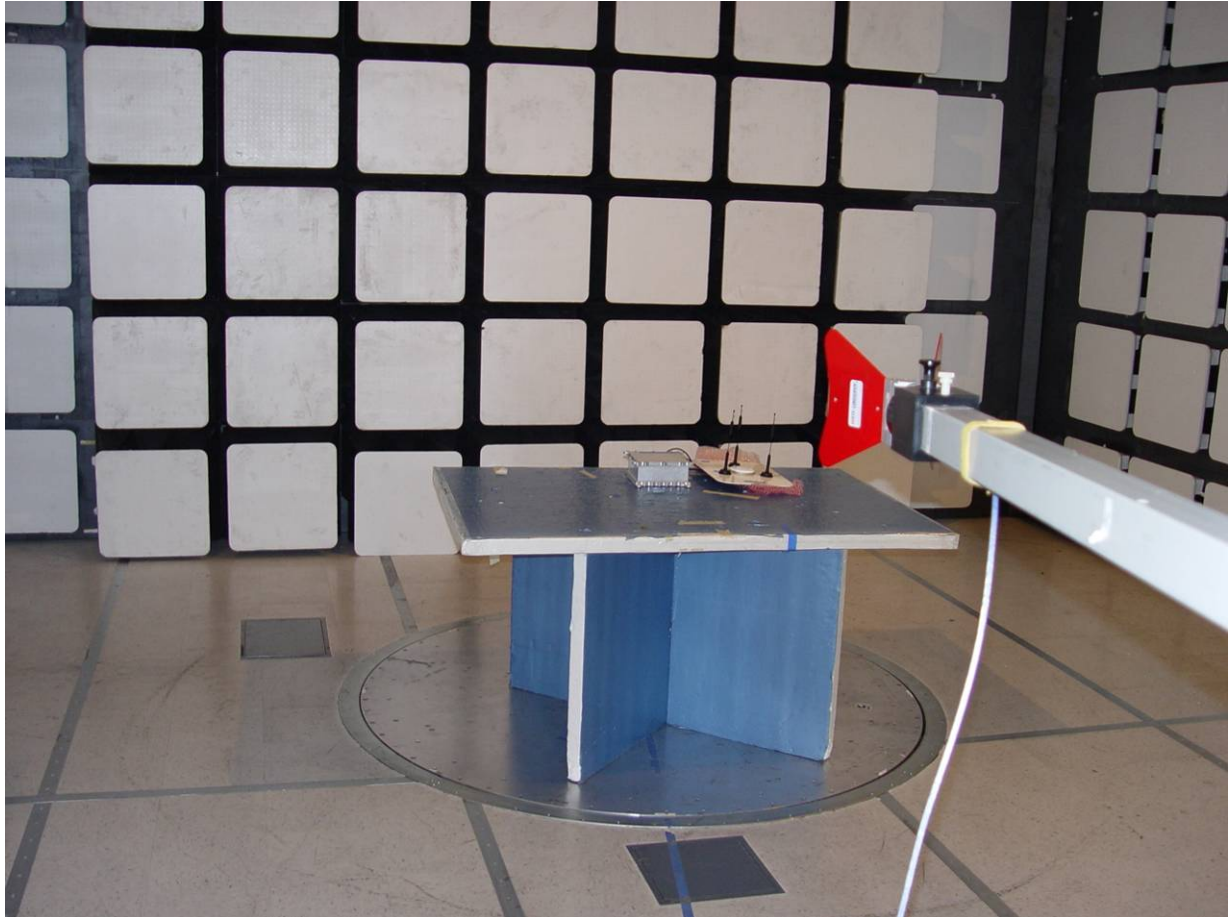

This test report may be reproduced in full only. The document may only be updated by MiCOM Labs personnel. Any changes will be noted in the Document History section of the report.

6.3. General Measurement Test Set-Up



This test report may be reproduced in full only. The document may only be updated by MiCOM Labs personnel. Any changes will be noted in the Document History section of the report.

6.4. Measurement Instrumentation



This test report may be reproduced in full only. The document may only be updated by MiCOM Labs personnel. Any changes will be noted in the Document History section of the report.



Title: WhereTrack WTK-5000
To: FCC 47 CFR Part 15.247 & IC RSS-210
Serial #: ETSD15-A2 Rev A
Issue Date: 6th February '09
Page: 96 of 97

7. TEST EQUIPMENT DETAILS

Asset #	Instrument	Manufacturer	Part #	Serial #
0088	Spectrum Analyzer	Hewlett Packard	8564E	3410A00141
0104	1-18GHz Horn Antenna	The Electro-Mechanics Company	3115	9205-3882
0134	Amplifier	Com Power	PA 122	181910
0158	Barometer /Thermometer	Control Co.	4196	E2846
0193	EMI Receiver	Rhode & Schwartz	ESI 7	838496/007
0252	SMA Cable	Megaphase	Sucoflex 104	None
0304	2.4GHzHz Notch Filter	Micro-Tronics	--	001
0310	2m SMA Cable	Micro-Coax	UFA210A-0-0787-3G03G0	209089-001
0312	3m SMA Cable	Micro-Coax	UFA210A-1-1181-3G0300	209092-001
0313	Coupler	Hewlett Packard	86205A	3140A01285
0314	30dB N-Type Attenuator	ARRA	N9444-30	1623
0070	Power Meter	Hewlett Packard	437B	3125U11552
0116	Power Sensor	Hewlett Packard	8485A	3318A19694
0117	Power Sensor	Hewlett Packard	8487D	3318A00371
0184	Pulse Limiter	Rhode & Schwartz	ESH3Z2	357.8810.52
0190	LISN	Rhode & Schwartz	ESH3Z5	836679/006
0293	BNC Cable	Megaphase	1689 1GVT4	15F50B001
0307	BNC Cable	Megaphase	1689 1GVT4	15F50B002

This test report may be reproduced in full only. The document may only be updated by MiCOM Labs personnel. Any changes will be noted in the Document History section of the report.



400 Boulder Court, Suite 200
Pleasanton, CA 94566, USA
Tel: 1.925.462.0304
Fax: 1.925.462.0306
www.micomlabs.com