

NOTES (UNLESS OTHERWISE SPECIFIED):

- THIS DRAWING REPRESENTS ASSEMBLY PART NUMBER WPT-3400, WHEREPORT IV REMOTE WHERETAG EXCITER.
- MAXIMUM WEIGHT 2.4 POUNDS (1.1 KG).

REVISION (REFER TO AGILE FOR PRIOR REVISIONS AND DATES)		
REV	ECO	DESCRIPTION
B	C01562	VIEWS UPDATED TO SHOW CORRECT LABELS

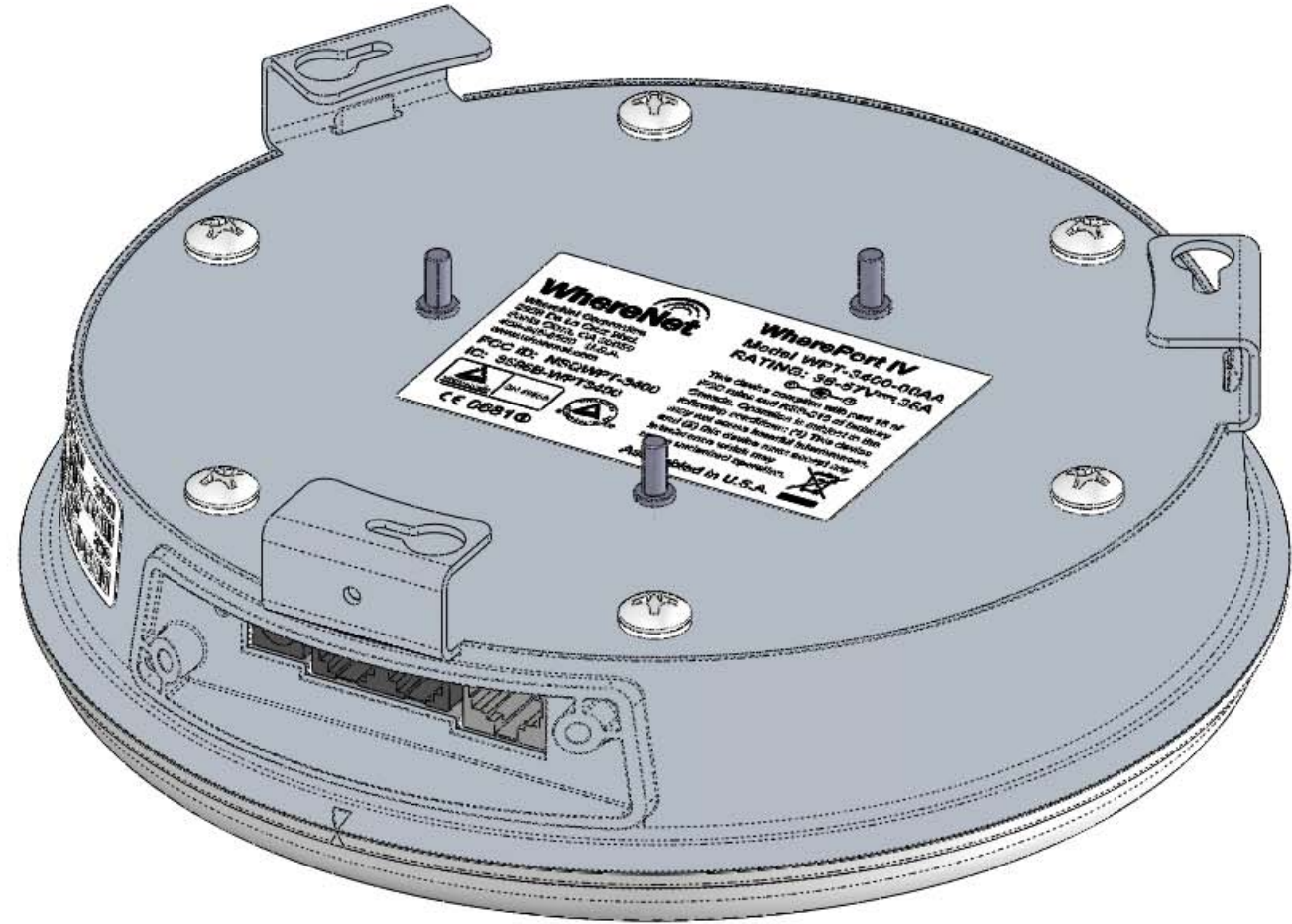
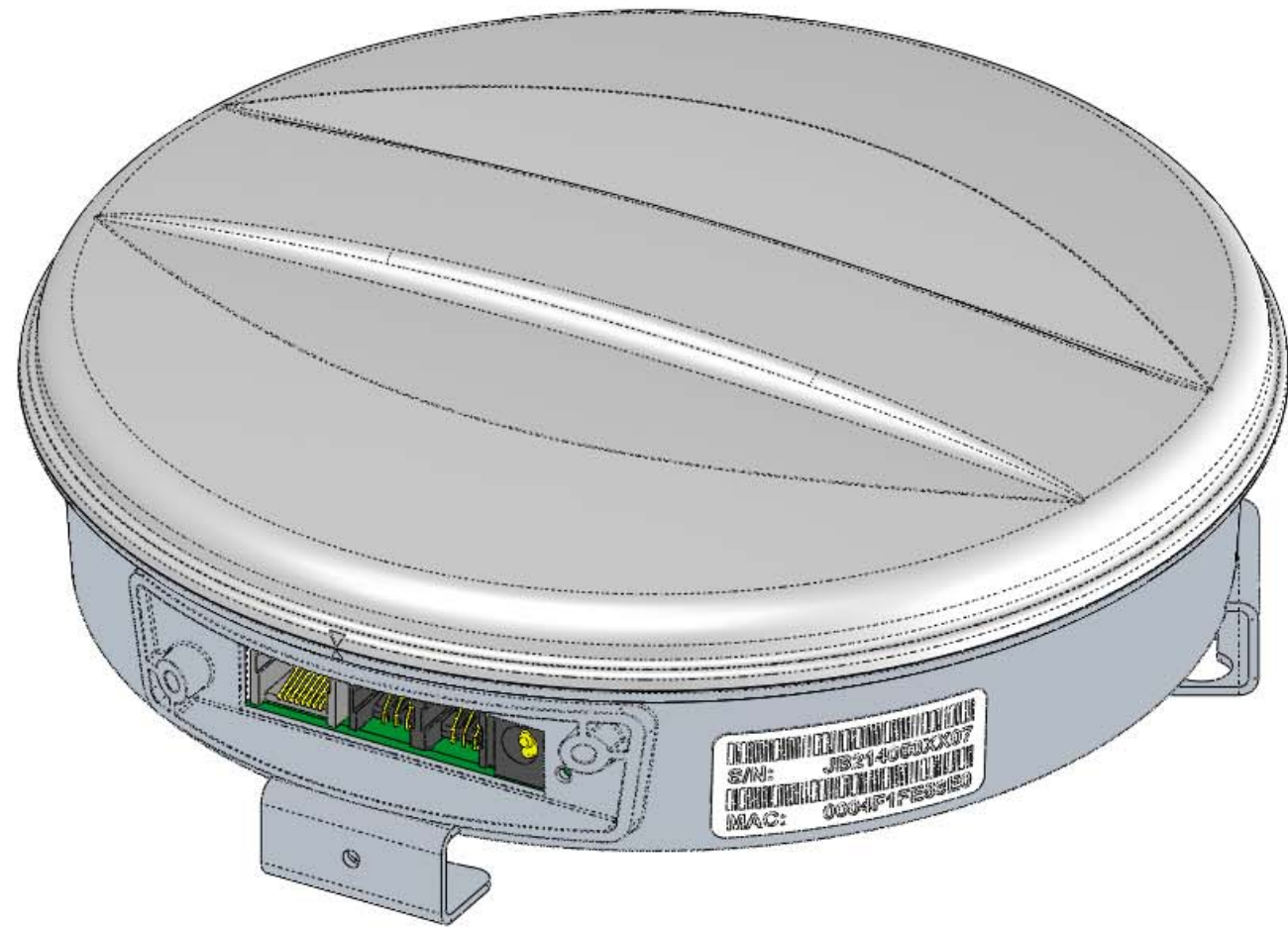

UNLESS OTHERWISE SPECIFIED:
 DIMENSIONS ARE IN INCHES
 DIMENSIONS IN [] ARE IN MM
 INTERPRET GEOMETRIC
 TOLERANCING PER ANSI Y14.5M
 TOLERANCES:
 ±X.X° = ±3.0°
 ±.XX = ±.05
 ±.XXX = ±.020

MATERIAL:
 SEE NOTES
 FINISH:
 SEE NOTES

DO NOT SCALE DRAWING

	NAME	DATE
DRAWN	JAW	9/16/07
RESP ENG	JAW	9/19/07
APPR.		
APPR.		
APPR.		

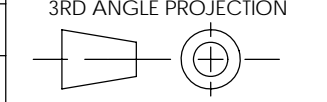

SW FILE: D1297

WhereNet 2858 DE LA CRUZ BLVD.
 SANTA CLARA, CA 95050
 408-845-8500 FAX 845-8501

TITLE:
**OUTLINE DRAWING,
 WHEREPORT IV**

SIZE	CAGE CODE	DWG. NO.	REV
B	1PQP8	D1297	B

SCALE: NONE SHEET 1 OF 4

PROPRIETARY AND CONFIDENTIAL
 THE INFORMATION CONTAINED IN THIS DRAWING IS THE SOLE PROPERTY OF
 WHERENET CORPORATION. ANY REPRODUCTION IN PART OR AS A WHOLE
 WITHOUT THE WRITTEN PERMISSION OF WHERENET CORPORATION IS PROHIBITED.

8 7 6 5 4 3 2 1

D
C
B
A

D
C
B
A

OPTIONAL MOUNTING BRACKET
(SUPPLIED WITH WPT-3400)

$\phi 7.62 [193.5]$

LOCKING SCREW FOR
MOUNTING BRACKET
(SUPPLIED WITH WPT-3400)

2.78 [70.7]
WITH
MOUNTING
BRACKET

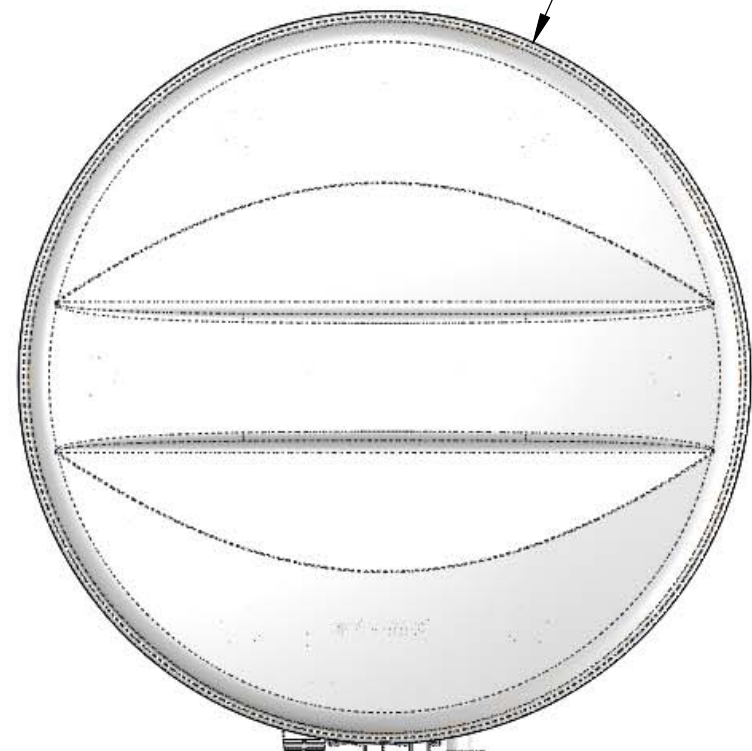
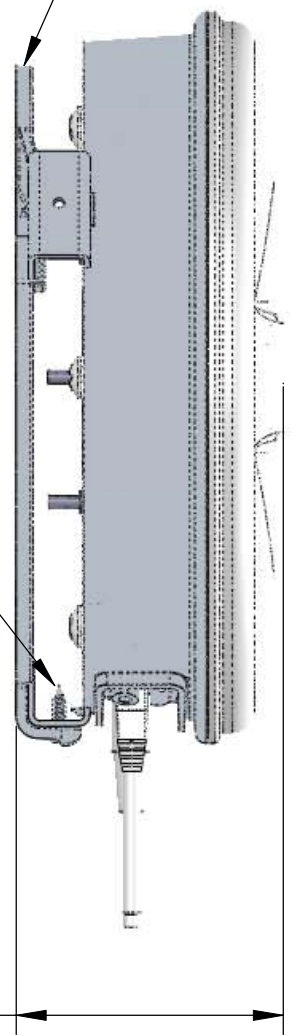

MOUNT WPT-3400
WITH CONNECTORS
FACING DOWN

CABLES NOT SUPPLIED WITH WPT-3400
SHOWN FOR REFERENCE ONLY

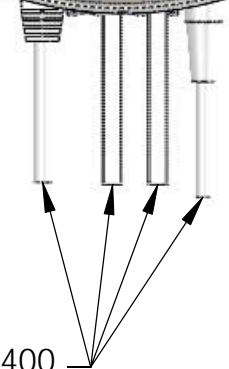

A
A

3X WPT-3400
MOUNTING
TABS

.57 [14.6]

2.66 [67.5]
WITHOUT
MOUNTING
BRACKET

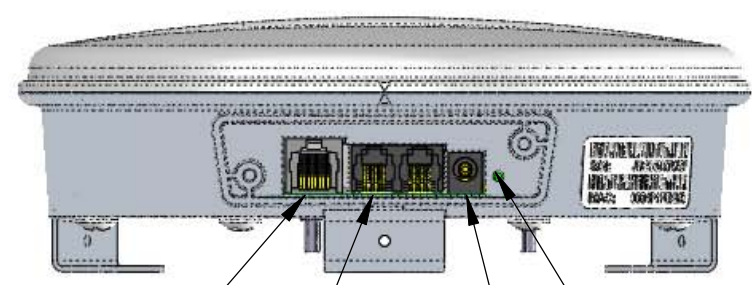
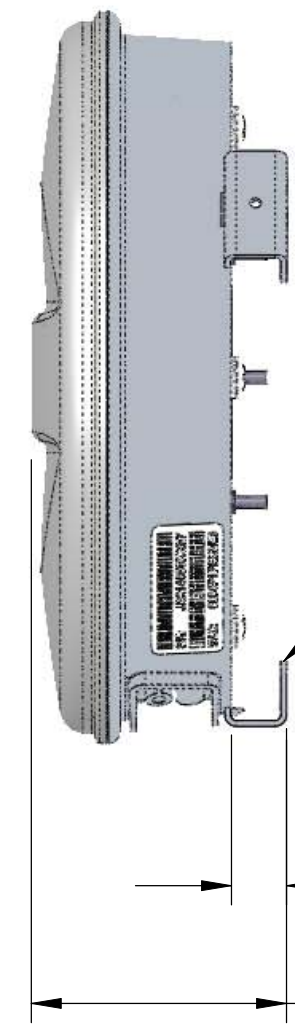

RJ-45 CONNECTOR

2X RJ-11 CONNECTORS

POWER LED

2.5 MM BARREL POWER CONNECTOR

SIZE	CAGE CODE	DWG. NO.	REV
B	1PQP8	D1297	B
SCALE: NONE		SHEET 2 OF 4	

8 7 6 5 4 3 2 1

KEYHOLE SLOT MOUNTING

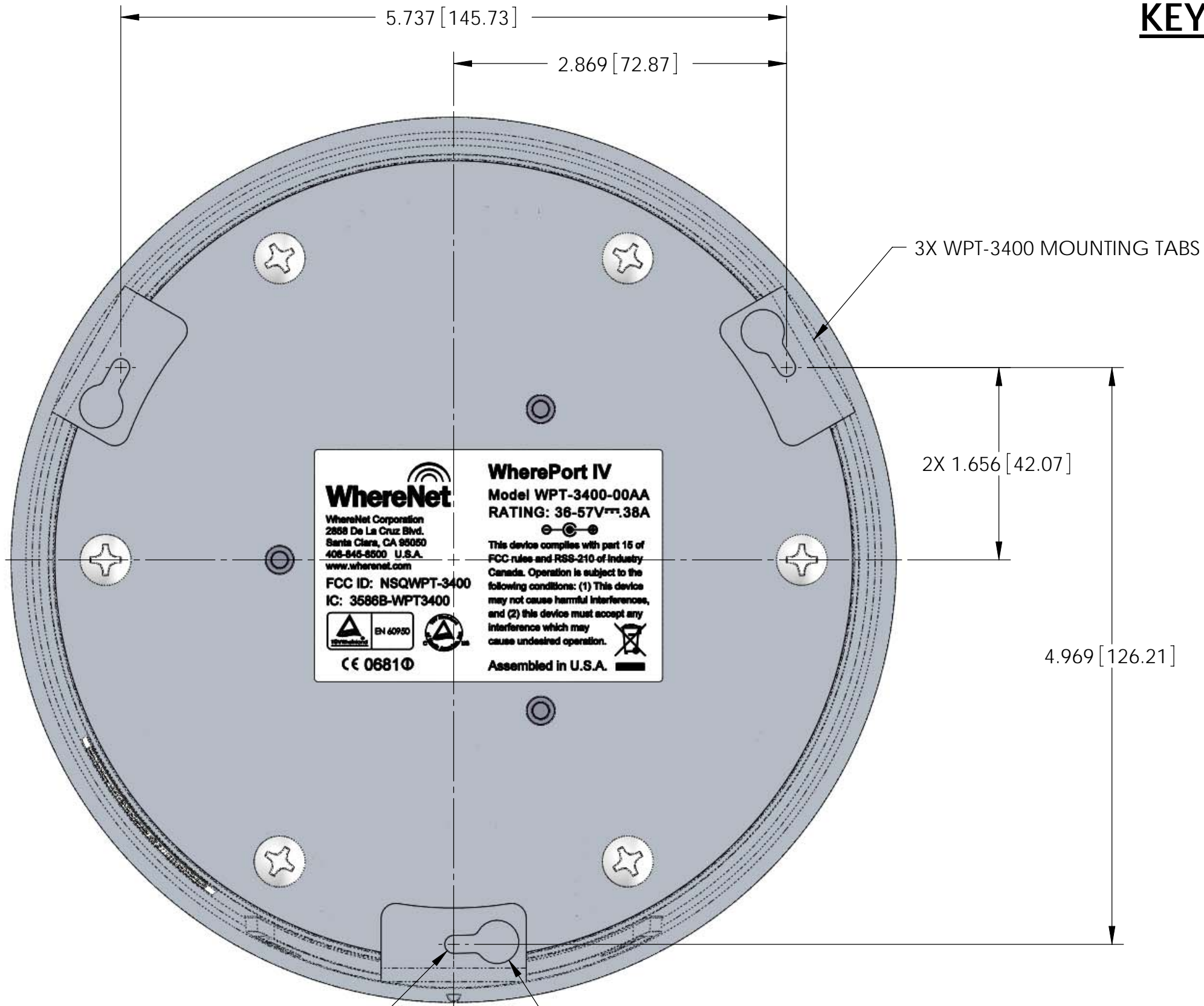

3X ϕ .156 [3.96]
MOUNTING LOCATIONS

3X ϕ .375 [9.53]

VIEW A-A

SIZE	CAGE CODE	DWG. NO.	REV
B	1PQP8	D1297	B
SCALE: 1:1		SHEET 3 OF 4	

MOUNTING BRACKET INSTALLATION

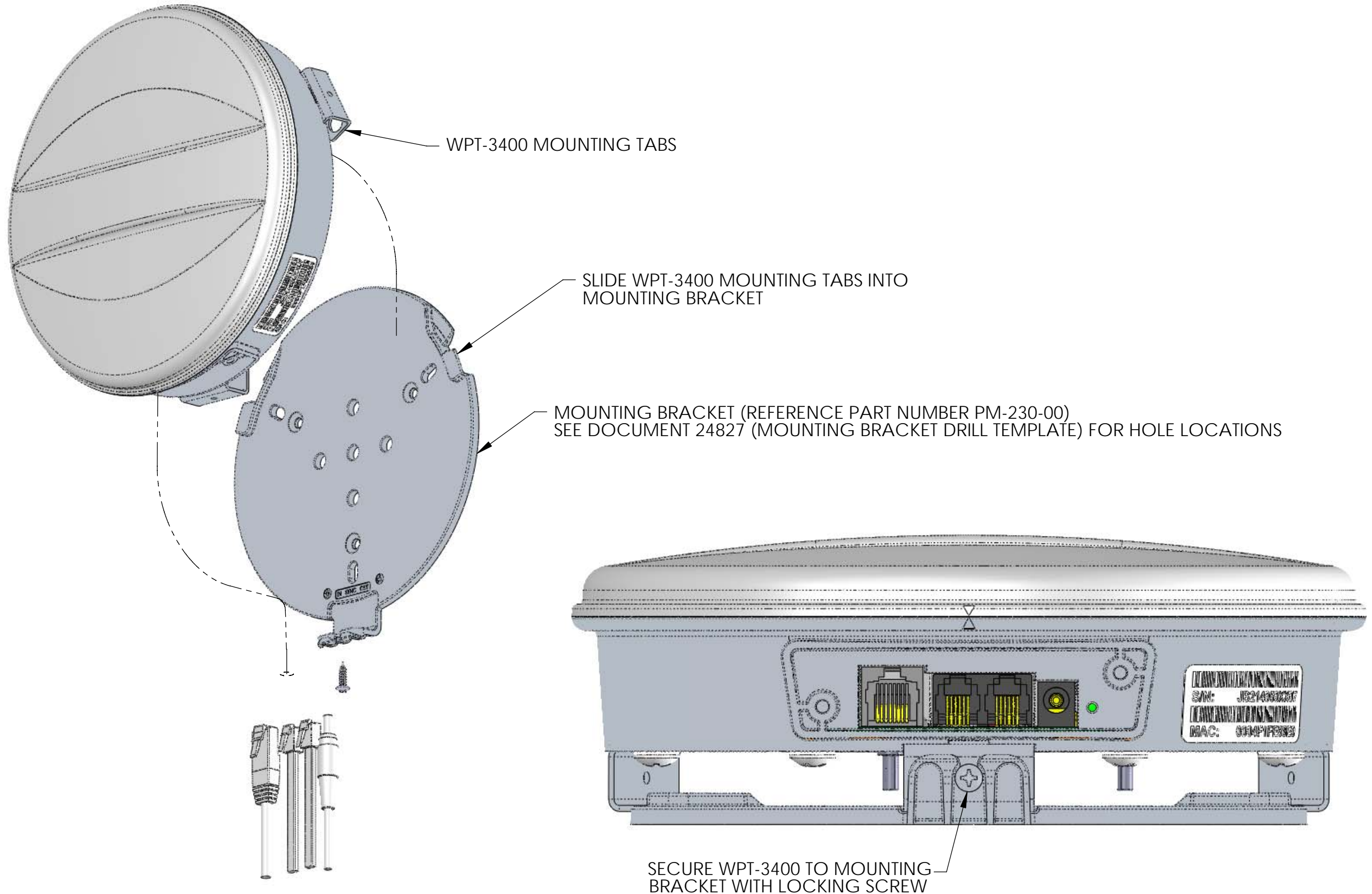

SIZE	CAGE CODE	DWG. NO.	REV
B	1PQP8	D1297	B
SCALE: NONE		SHEET 4 OF 4	