

# ENGINEERING TEST REPORT

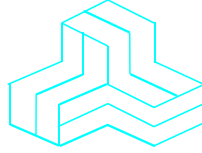

**OEM 900 MHz Spread Spectrum Wireless Module**  
**Model: HP900**  
**FCC ID: NS9HP900**

*Applicant:*

**Microhard Systems Inc.**  
150 Country Hills Landing NW  
Calgary, Alberta  
Canada T3K 5P3

*In Accordance With*

**Federal Communications Commission (FCC)**  
**Part 15, Subpart C, Section 15.247 Frequency Hopping Spread Spectrum (FHSS)**

**UltraTech's File No.: 19MCRS108\_FCC15C247**

This Test report is Issued under the Authority of  
Tri M. Luu  
Vice President of Engineering  
UltraTech Group of Labs

Date: February 27, 2019

Report Prepared by: Dan Huynh

Tested by: Hung Trinh

Issued Date: February 27, 2019

Test Dates:  
November 2 - 3, 2018  
December 1 - 14, 2018  
February 22, 2019

- *The results in this Test Report apply only to the sample(s) tested, and the sample tested is randomly selected.*
- *This report must not be used by the client to claim product endorsement by NVLAP or any agency of the US Government.*
- *This test report shall not be reproduced, except in full, without a written approval from UltraTech*

## UltraTech

3000 Bristol Circle, Oakville, Ontario, Canada L6H 6G4  
Tel.: (905) 829-1570 Fax.: (905) 829-8050

Website: [www.ultratech-labs.com](http://www.ultratech-labs.com), Email: [vic@ultratech-labs.com](mailto:vic@ultratech-labs.com), Email: [tri@ultratech-labs.com](mailto:tri@ultratech-labs.com)



APEC TEL CA0001



1309



CA 0001/2049



AT-1945



SL2-IN-E-1119R



Korea KCC-RRR  
CA2049

**TABLE OF CONTENTS**

**EXHIBIT 1. INTRODUCTION..... 1**

1.1. SCOPE ..... 1

1.2. RELATED SUBMITTAL(S)/GRANT(S) ..... 1

1.3. NORMATIVE REFERENCES ..... 1

**EXHIBIT 2. PERFORMANCE ASSESSMENT ..... 2**

2.1. CLIENT INFORMATION ..... 2

2.2. EQUIPMENT UNDER TEST (EUT) INFORMATION ..... 2

2.3. EUT'S TECHNICAL SPECIFICATIONS..... 3

2.4. ASSOCIATED ANTENNA DESCRIPTIONS ..... 3

2.5. LIST OF EUT'S PORTS..... 3

2.6. ANCILLARY EQUIPMENT ..... 4

**EXHIBIT 3. EUT OPERATING CONDITIONS AND CONFIGURATIONS DURING TESTS ..... 5**

3.1. CLIMATE TEST CONDITIONS ..... 5

3.2. OPERATIONAL TEST CONDITIONS & ARRANGEMENT FOR TESTS..... 5

**EXHIBIT 4. SUMMARY OF TEST RESULTS..... 6**

4.1. LOCATION OF TESTS ..... 6

4.2. APPLICABILITY & SUMMARY OF EMC EMISSION TEST RESULTS ..... 6

4.3. MODIFICATIONS INCORPORATED IN THE EUT FOR COMPLIANCE PURPOSES ..... 6

**EXHIBIT 5. TEST DATA ..... 7**

5.1. POWER LINE CONDUCTED EMISSIONS [§15.207(a)]..... 7

5.2. COMPLIANCE WITH FCC PART 15 – GENERAL TECHNICAL REQUIREMENTS ..... 12

5.3. PROVISIONS FOR FREQUENCY HOPPING SYSTEMS [§ 15.247(a)(1)]..... 14

5.4. PEAK CONDUCTED OUTPUT POWER [§ 15.247(b)(2)]..... 38

5.5. TRANSMITTER SPURIOUS RADIATED EMISSIONS AT 3 METERS [§§ 15.247(d), 15.209 & 15.205] ..... 42

5.6. RF EXPOSURE REQUIRMENTS [§§ 15.247(i), 1.1310 & 2.1091]..... 77

**EXHIBIT 6. TEST EQUIPMENT LIST ..... 79**

**EXHIBIT 7. MEASUREMENT UNCERTAINTY ..... 80**

7.1. LINE CONDUCTED EMISSION MEASUREMENT UNCERTAINTY..... 80

7.2. RADIATED EMISSION MEASUREMENT UNCERTAINTY ..... 80

**EXHIBIT 1. INTRODUCTION**

**1.1. SCOPE**

<b>Reference:</b>	FCC Part 15, Subpart C, Section 15.247
<b>Title:</b>	Code of Federal Regulations (CFR), Title 47 – Telecommunication, Part 15
<b>Purpose of Test:</b>	Equipment Certification for Part 15C Spread Spectrum Transmitter
<b>Test Procedures:</b>	<ul style="list-style-type: none"> <li>▪ ANSI C63.4</li> <li>▪ ANSI C63.10</li> <li>▪ FCC Public Notice DA 00-705</li> </ul>
<b>Environmental Classification:</b>	<input checked="" type="checkbox"/> Commercial, industrial or business environment <input checked="" type="checkbox"/> Residential environment

**1.2. RELATED SUBMITTAL(S)/GRANT(S)**

None.

**1.3. NORMATIVE REFERENCES**

Publication	Year	Title
47 CFR Parts 0-19	2018	Code of Federal Regulations (CFR), Title 47 – Telecommunication
ANSI C63.4	2014	American National Standard for Methods of Measurement of Radio-Noise Emissions from Low-Voltage Electrical and Electronic Equipment in the Range of 9 KHz to 40 GHz
ANSI C63.10	2013	American National Standard of Procedures for Compliance Testing of Unlicensed Wireless Devices
FCC Public Notice DA 00-705	2000	Filing and Measurement Guidelines for Frequency Hopping Spread Spectrum Systems
FCC ET Docket No. 99-231	2002	Amendment to FCC Part 15 of the Commission's Rules Regarding to Spread Spectrum Devices

## EXHIBIT 2. PERFORMANCE ASSESSMENT

### 2.1. CLIENT INFORMATION

APPLICANT	
<b>Name:</b>	Microhard Systems Inc.
<b>Address:</b>	150 Country Hills Landing NW Calgary, Alberta Canada T3K 5P3
<b>Contact Person:</b>	Mr. Hany Shenouda Phone #: 403 248-0028 Fax #: 403 248 2762 Email Address: shenouda@microhardcorp.com

MANUFACTURER	
<b>Name:</b>	Microhard Systems Inc.
<b>Address:</b>	150 Country Hills Landing NW Calgary, Alberta Canada T3K 5P3
<b>Contact Person:</b>	Mr. Hany Shenouda Phone #: 403 248-0028 Fax #: 403 248-2762 Email Address: shenouda@microhardcorp.com

### 2.2. EQUIPMENT UNDER TEST (EUT) INFORMATION

The following information (with the exception of the Date of Receipt) has been supplied by the applicant.

<b>Brand Name:</b>	Microhard Systems Inc.
<b>Product Name:</b>	OEM 900 MHz Spread Spectrum Wireless Module
<b>Model Name or Number:</b>	HP900
<b>Serial Number:</b>	Test Sample
<b>Type of Equipment:</b>	Spread Spectrum Transmitter
<b>Input Power Supply Type:</b>	External Regulated DC Sources
<b>Primary User Functions of EUT:</b>	Wireless data communication Ethernet and serial

**2.3. EUT'S TECHNICAL SPECIFICATIONS**

<b>Transmitter</b>	
<b>Equipment Type:</b>	<ul style="list-style-type: none"> <li>▪ Mobile</li> <li>▪ Base Station (fixed use)</li> </ul>
<b>Intended Operating Environment:</b>	Residential Commercial, industrial or business environment
<b>Power Supply Requirement:</b>	3.3 VDC
<b>RF Output Power Rating:</b>	19 - 30 dBm typical
<b>Operating Frequency Range:</b>	902.4 – 927.65 MHz
<b>RF Output Impedance:</b>	50 Ω
<b>Duty Cycle:</b>	Continuous
<b>Modulation Type:</b>	GFSK
<b>Antenna Connector Type:</b>	PAD on the HP900 module

**2.4. ASSOCIATED ANTENNA DESCRIPTIONS**

<b>Antenna Type</b>	<b>Maximum Gain (dBi)</b>
Rubber Duck Antenna	3
Yagi Antenna	13.15
Patch Antenna	8
Omni Directional Antenna	8.15
Puck Antenna	4

**2.5. LIST OF EUT'S PORTS**

<b>Port Number</b>	<b>EUT's Port Description</b>	<b>Number of Identical Ports</b>	<b>Connector Type</b>	<b>Cable Type (Shielded/Non-shielded)</b>
1	RF IN/OUT Port	1	PAD	No cable, direct connection
2	DC Supply & I/O Port	1	Pin Header	No cable, direct connection

**2.6. ANCILLARY EQUIPMENT**

The EUT was tested while connected to the following representative configuration of ancillary equipment necessary to exercise the ports during tests:

<b>Ancillary Equipment # 1</b>	
Description:	Test Jig
Brand name:	Microhard Systems Inc.
Model Name or Number:	N/A
Connected to EUT's Port:	I/O Port

<b>Ancillary Equipment # 2</b>	
Description:	AC/DC Adapter
Brand name:	BIRon Switching Power Supply
Model Name or Number:	BI24-120200-AdU
Connected to EUT's Port:	Test Jig of the EUT

**EXHIBIT 3. EUT OPERATING CONDITIONS AND CONFIGURATIONS DURING TESTS**

**3.1. CLIMATE TEST CONDITIONS**

The climate conditions of the test environment are as follows:

Temperature:	21 to 23 °C
Humidity:	45 to 58%
Pressure:	102 kPa
Power Input Source:	3.3 VDC via test jig

**3.2. OPERATIONAL TEST CONDITIONS & ARRANGEMENT FOR TESTS**

<b>Operating Modes:</b>	<ul style="list-style-type: none"> <li>▪ Each of lowest, middle and highest channel frequencies transmits continuously for emissions measurements.</li> <li>▪ The EUT operates in normal Frequency Hopping mode for occupancy duration, and frequency separation.</li> </ul>
<b>Special Test Software &amp; Hardware:</b>	Test software provided by the Applicant is installed to allow the EUT to operate in hopping mode or at each channel frequency continuously. For example, the transmitter will be operated at each of lowest, middle and highest frequencies individually continuously during testing.
<b>Transmitter Test Antenna:</b>	The EUT is tested with the antenna fitted in a manner typical of normal intended use as non-integral antenna equipment as described with the test results.

<b>Transmitter Test Signals</b>	
<b>Frequency Band(s):</b>	902.4 – 927.65 MHz
<b>Frequency(ies) Tested:</b> (Near lowest, near middle & near highest frequencies in the frequency range of operation.)	902.4 MHz, 903.0 MHz, 914.9 MHz, 915.0 MHz 927.5 MHz, 927.6 MHz, 927.65 MHz
<b>RF Power Output:</b> (measured maximum output power at antenna terminals)	30 dBm, 1 W (conducted)
<b>Normal Test Modulation:</b>	GFSK
<b>Modulating Signal Source:</b>	Internal

## EXHIBIT 4. SUMMARY OF TEST RESULTS

### 4.1. LOCATION OF TESTS

All of the measurements described in this report were performed at Ultratech Group of Labs located in the city of Oakville, Province of Ontario, Canada.

- AC Power Line Conducted Emissions were performed in UltraTech's shielded room, 24'(L) by 16'(W) by 8'(H).
- Radiated Emissions were performed at the Ultratech's 3-10 TDK Semi-Anechoic Chamber situated in the Town of Oakville, province of Ontario. This test site been calibrated in accordance with ANSI C63.4, and found to be in compliance with the requirements of Sec. 2.948 of the FCC Rules. The descriptions and site measurement data of the Oakville 3-10 TDK Semi-Anechoic Chamber has been filed with ANAB File No.: AT-1945.

### 4.2. APPLICABILITY & SUMMARY OF EMC EMISSION TEST RESULTS

FCC Section(s)	Test Requirements	Compliance (Yes/No)
15.203	Antenna requirements	Yes
15.207(a)	AC Power Line Conducted Emissions	Yes
15.247(a)	Provisions for Frequency Hopping Systems	Yes
15.247(b)(2)	Peak Conducted Output Power	Yes
15.247(d), 15.209 & 15.205	Transmitter Spurious Radiated Emissions	Yes
15.247(i), 1.1307, 1.1310, 2.1091	RF Exposure	Yes

### 4.3. MODIFICATIONS INCORPORATED IN THE EUT FOR COMPLIANCE PURPOSES

None.



**EXHIBIT 5. TEST DATA**

**5.1. POWER LINE CONDUCTED EMISSIONS [§15.207(a)]**

**5.1.1. Limit(s)**

The equipment shall meet the limits of the following table:

Frequency of emission (MHz)	Conducted Limits (dB $\mu$ V)	
	Quasi-peak	Average
0.15–0.5 .....	66 to 56* .....	56 to 46*
0.5–5 .....	56 .....	46
5–30 .....	60 .....	50

\*Decreases linearly with the logarithm of the frequency

**5.1.2. Method of Measurements**

ANSI C63.4

**5.1.3. Test Arrangement**

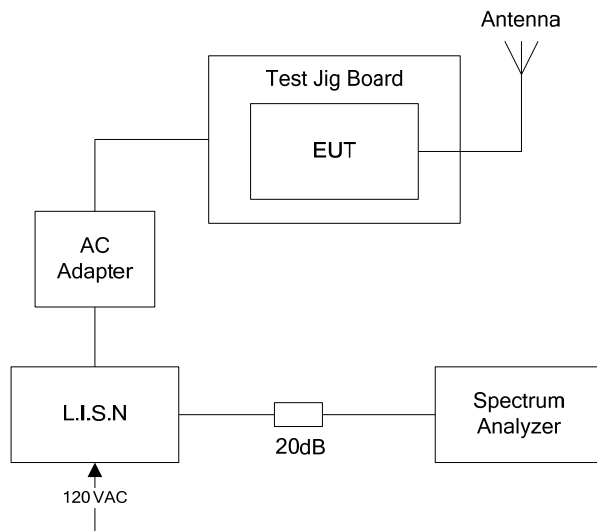

5.1.4. Test Data

Plot 5.1.4.1. Power Line Conducted Emissions (Tx Mode)  
 Line Voltage: 120 VAC; Line Tested: Hot

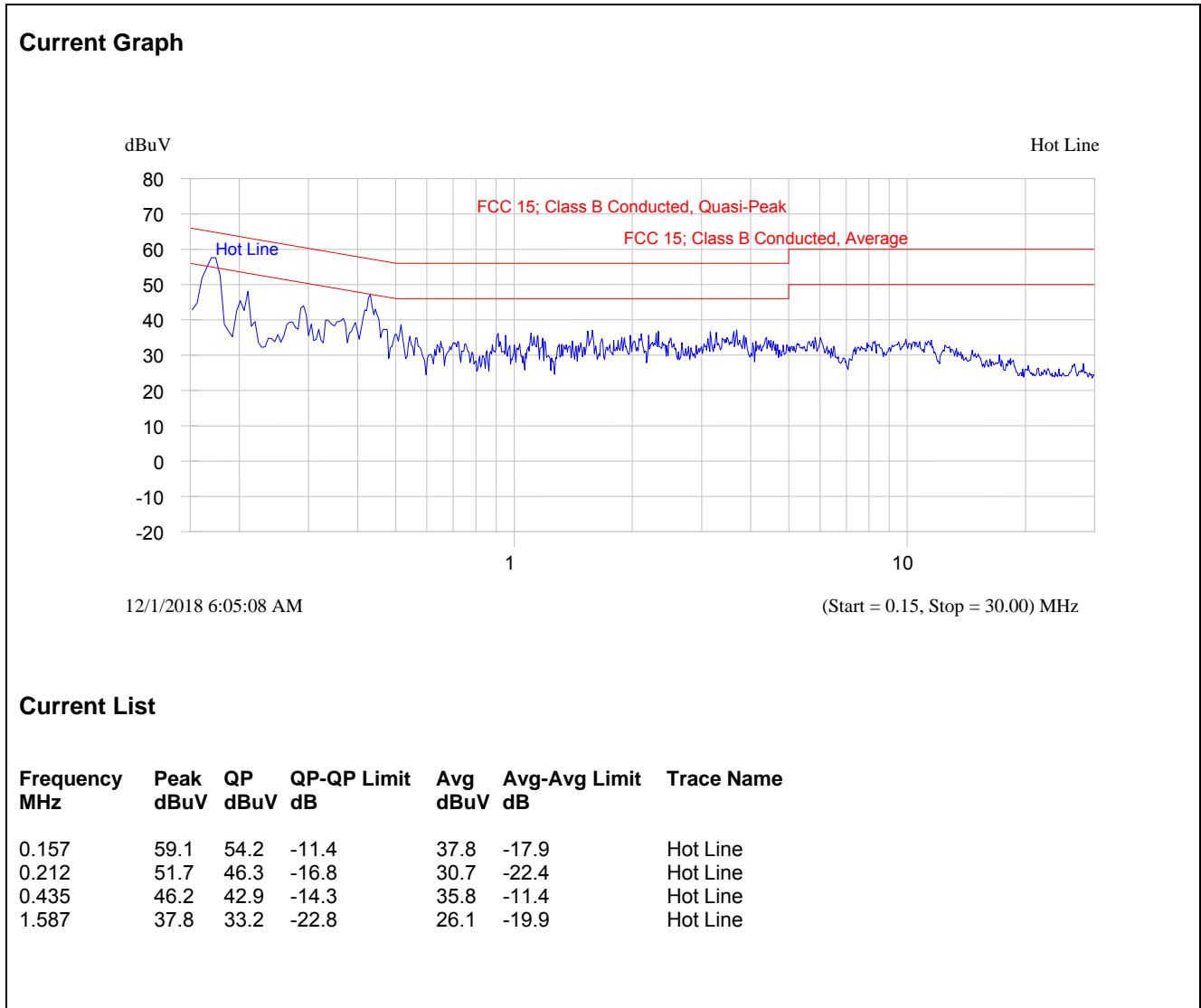

Plot 5.1.4.2. Power Line Conducted Emissions (Tx Mode)  
 Line Voltage: 120 VAC; Line Tested: Neutral

**Current Graph**

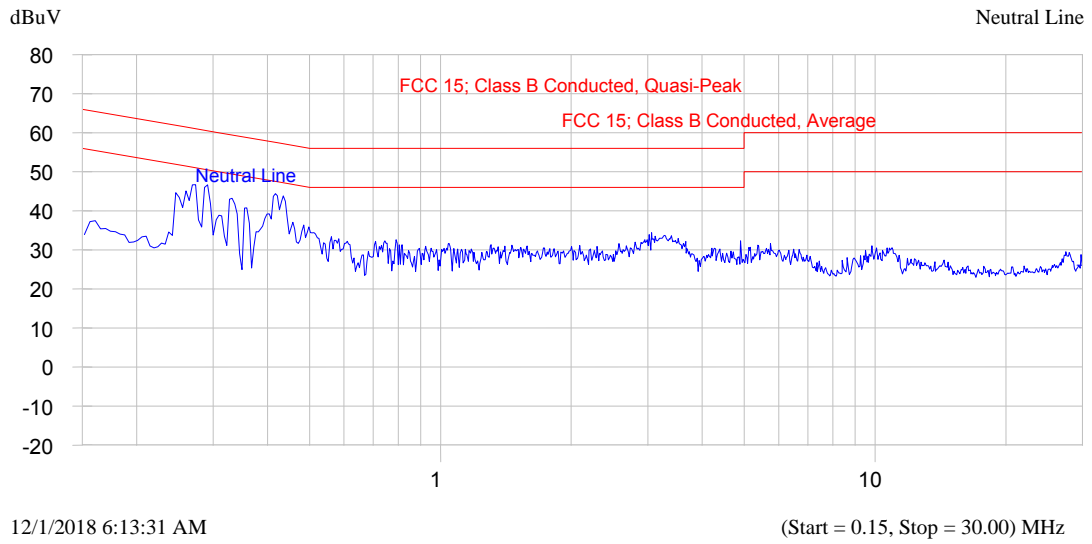

**Current List**

Frequency MHz	Peak dBuV	QP dBuV	QP-QP Limit dB	Avg dBuV	Avg-Avg Limit dB	Trace Name
0.269	47.2	41.7	-19.4	31.6	-19.5	Neutral Line
0.285	47.1	43.9	-16.7	35.2	-15.5	Neutral Line
0.330	44.7	40.2	-19.2	33.5	-15.9	Neutral Line
0.422	47.9	45.8	-11.6	37.4	-10.0	Neutral Line
3.057	38.3	33.1	-22.9	27.4	-18.6	Neutral Line

**Plot 5.1.4.3. Power Line Conducted Emissions (Rx Mode)**  
 Line Voltage: 120 VAC; Line Tested: Hot

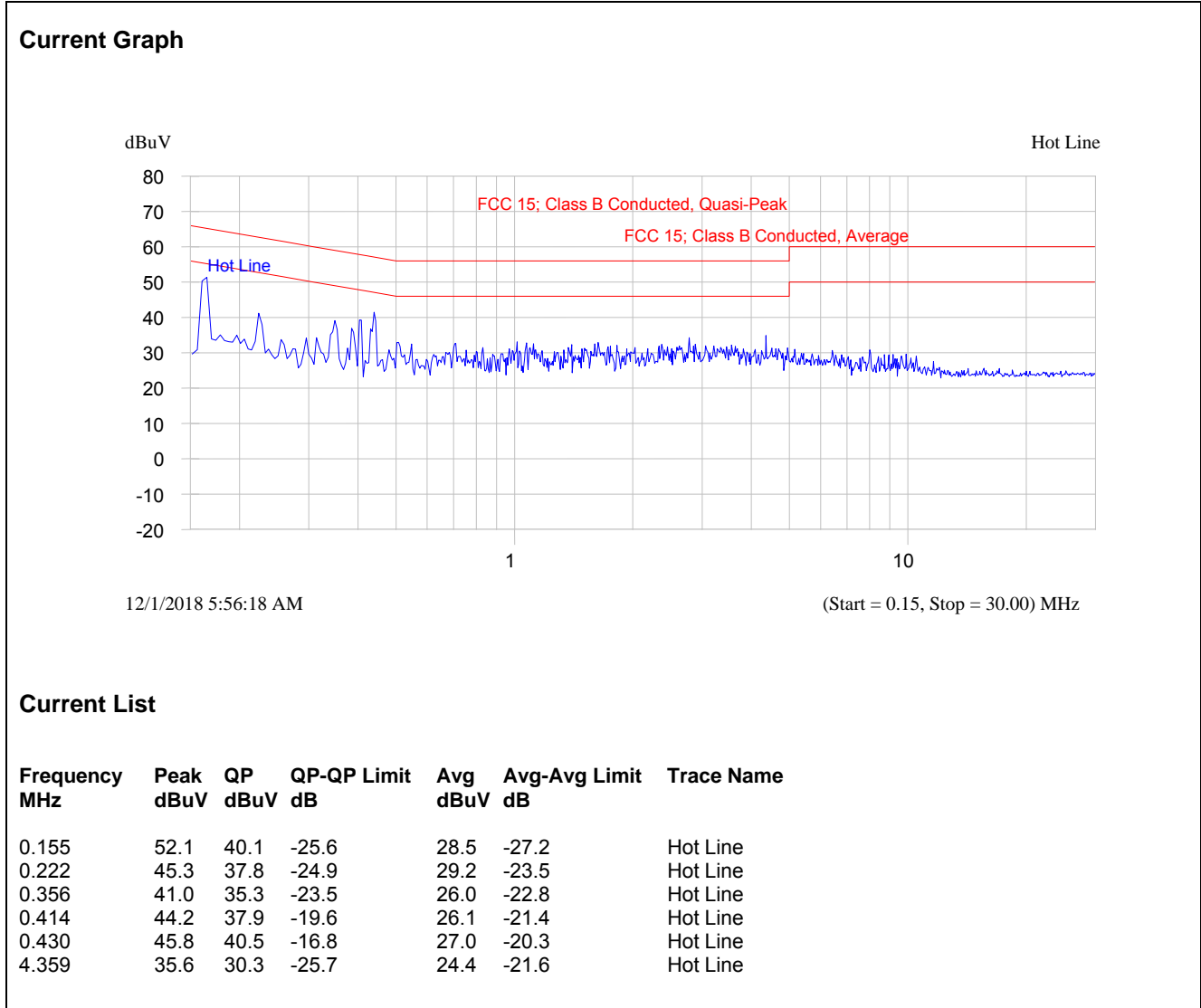

**Plot 5.1.4.4. Power Line Conducted Emissions (Rx Mode)**  
 Line Voltage: 120 VAC; Line Tested: Neutral

**Current Graph**

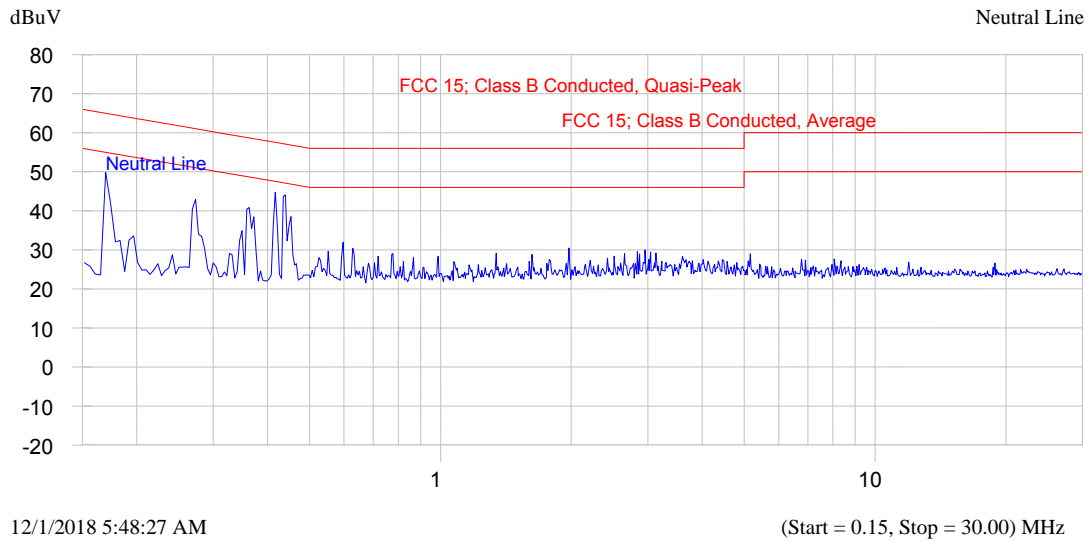

**Current List**

Frequency MHz	Peak dBuV	QP dBuV	QP-QP Limit dB	Avg dBuV	Avg-Avg Limit dB	Trace Name
0.171	38.9	38.1	-26.8	28.8	-26.1	Neutral Line
0.270	44.7	31.9	-29.3	25.2	-26.0	Neutral Line
0.357	42.9	37.2	-21.6	25.7	-23.1	Neutral Line
0.424	49.4	44.2	-13.2	27.9	-19.5	Neutral Line
0.430	48.9	43.0	-14.2	27.4	-19.9	Neutral Line

**5.2. COMPLIANCE WITH FCC PART 15 – GENERAL TECHNICAL REQUIREMENTS**

FCC Section	FCC Rules	Manufacturer’s Clarification
15.203	<p>Described how the EUT complies with the requirement that either its antenna is permanently attached, or that it employs a unique antenna connector, for every antenna proposed for use with the EUT.</p> <p>The exception is in those cases where EUT must be professionally installed. In order to demonstrate that professional installation is required, the following 3 points must be addressed:</p> <ul style="list-style-type: none"> <li>➤ The application (or intended use) of the EUT</li> <li>➤ The installation requirements of the EUT</li> <li>➤ The method by which the EUT will be marketed</li> </ul>	The antenna employs a unique antenna connector.
15.204	<p>Provided the information for every antenna proposed for use with the EUT:</p> <ul style="list-style-type: none"> <li>➤ type (e.g. Yagi, patch, grid, dish, etc...),</li> <li>➤ manufacturer and model number</li> <li>➤ gain with reference to an isotropic radiator</li> </ul>	See proposed antenna listed in user manual.
15.247(a)	Description of how the EUT meets the definition of a frequency hopping spread spectrum, found in Section 2.1. Based on the technical description.	See Operational Description
15.247(a)	Pseudo Frequency Hopping Sequence: Describe how the hopping sequence is generated. Provide an example of the hopping sequence channels, in order to demonstrate that the sequence meets the requirements specified in the definition of a frequency hopping spread spectrum system, found in Section 2.1	See Operational Description
15.247(a)	Equal Hopping Frequency Use: Describe how each individual EUT meets the requirement that each of its hopping channels is used equally on average (e.g. that each new transmission event begins on the next channel in the hopping sequence after final channel used in the previous transmission events).	See Operational Description
15.247(a)	System Receiver Input Bandwidth: Describe how the associated receiver(s) complies with the requirement that its input bandwidth (either RF or IF) matches the bandwidth of the transmitted signal.	See Operational Description

FCC Section	FCC Rules	Manufacturer's Clarification
15.247(a)	<u>System Receiver Hopping Capability:</u> Describe how the associated receiver(s) has the ability to shift frequencies in synchronization with the transmitted signals	See Operational Description
15.247(g)	Describe how the EUT complies with the requirement that it be designed to be capable of operating as a true frequency hopping system	See Operational Description
15.247(h)	Describe how the EUT complies with the requirement that it not have the ability to coordinated with other FHSS is an effort to avoid the simultaneous occupancy of individual hopping frequencies by multiple transmitters	See Operational Description

### 5.3. PROVISIONS FOR FREQUENCY HOPPING SYSTEMS [§ 15.247(a)(1)]

#### 5.3.1. Limits

§ 15.247(a)(1): Frequency hopping systems shall have hopping channel carrier frequencies separated by a minimum of 25 kHz or the 20 dB bandwidth of the hopping channel, whichever is greater. Alternatively, frequency hopping systems operating in the 2400-2483.5 MHz band may have hopping channel carrier frequencies that are separated by 25 kHz or two-thirds of the 20 dB bandwidth of the hopping channel, whichever is greater, provided the systems operate with an output power no greater than 125 mW. The system shall hop to channel frequencies that are selected at the system hopping rate from a pseudo randomly ordered list of hopping frequencies. Each frequency must be used equally on the average by each transmitter. The system receivers shall have input bandwidths that match the hopping channel bandwidths of their corresponding transmitters and shall shift frequencies in synchronization with the transmitted signals.

§ 15.247(a)(1)(i) For frequency hopping systems operating in the 902-928 MHz band: if the 20 dB bandwidth of the hopping channel is less than 250 kHz, the system shall use at least 50 hopping frequencies and the average time of occupancy on any frequency shall not be greater than 0.4 seconds within a 20 second period; if the 20 dB bandwidth of the hopping channel is 250 kHz or greater, the system shall use at least 25 hopping frequencies and the average time of occupancy on any frequency shall not be greater than 0.4 seconds within a 10 second period. The maximum allowed 20 dB bandwidth of the hopping channel is 500 kHz.

#### 5.3.2. Method of Measurements

ANSI C63.10-2013, Sections 6.9.2, 7.8.2, 7.8.3 and 7.8.4

#### 5.3.3. Test Arrangement

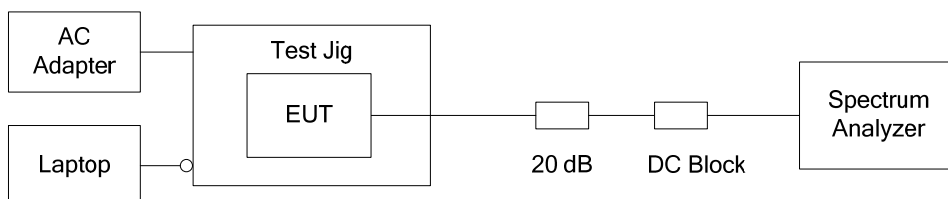



5.3.4. Test Data

Test Description	FCC Specification	Measured Values		Comments
Frequency Hopping Systems Requirements	The system shall hop to channel frequencies that are selected at the system hopping rate from a pseudo randomly ordered list of hopping frequencies. Each frequency must be used equally on the average by each transmitter. The system receivers shall have input bandwidths that match the hopping channel bandwidths of their corresponding transmitters and shall shift frequencies in synchronization with the transmitted signals.	--		See Note 1
BW of the hopping channel	The maximum allowed 20 dB bandwidth of the hopping channel is 500 kHz.	<b>Channel Spacing</b>	<b>20 dB BW</b>	See Note 2
		100 kHz	44.23 kHz	
		250 kHz	210.74 kHz	
500 kHz	483.97 kHz			
Channel Hopping Frequency Separation	Frequency hopping systems shall have hopping channel carrier frequencies separated by a minimum of 25 kHz or the 20 dB bandwidth of the hopping channel, whichever is greater.	100 kHz for 100 kHz CS 250 kHz for 250 kHz CS 500 kHz for 500 kHz CS		See Note 2
Number of hopping frequencies	If the 20 dB bandwidth of the hopping channel is less than 250 kHz, the system shall use at least 50 hopping frequencies; if the 20 dB bandwidth of the hopping channel is 250 kHz or greater, the system shall use at least 25 hopping frequencies	50 hopping frequencies		See Note 1 and 2
Average Time of Occupancy	if the 20 dB bandwidth of the hopping channel is less than 250 kHz, the system shall use at least 50 hopping frequencies and the average time of occupancy on any frequency shall not be greater than 0.4 seconds within a 20 second period; if the 20 dB bandwidth of the hopping channel is 250 kHz or greater, the system shall use at least 25 hopping frequencies and the average time of occupancy on any frequency shall not be greater than 0.4 seconds within a 10 second period	<b>Channel Spacing</b>	<b>Dwell Time</b>	See Note 2
		100 kHz	79.45 ms in 20s period	
		250 kHz	5.56 ms in 10s period	
500 kHz	3.19 ms in 10s period			
<p><b>Note 1:</b> See operational description exhibit for details.  <b>Note 2:</b> See the following plots for details.</p>				

Plot 5.3.4.1. 20 dB Bandwidth, 902.4 MHz, Low Data Rate, 100 kHz CS, High Power, Raw Power Setting at 10

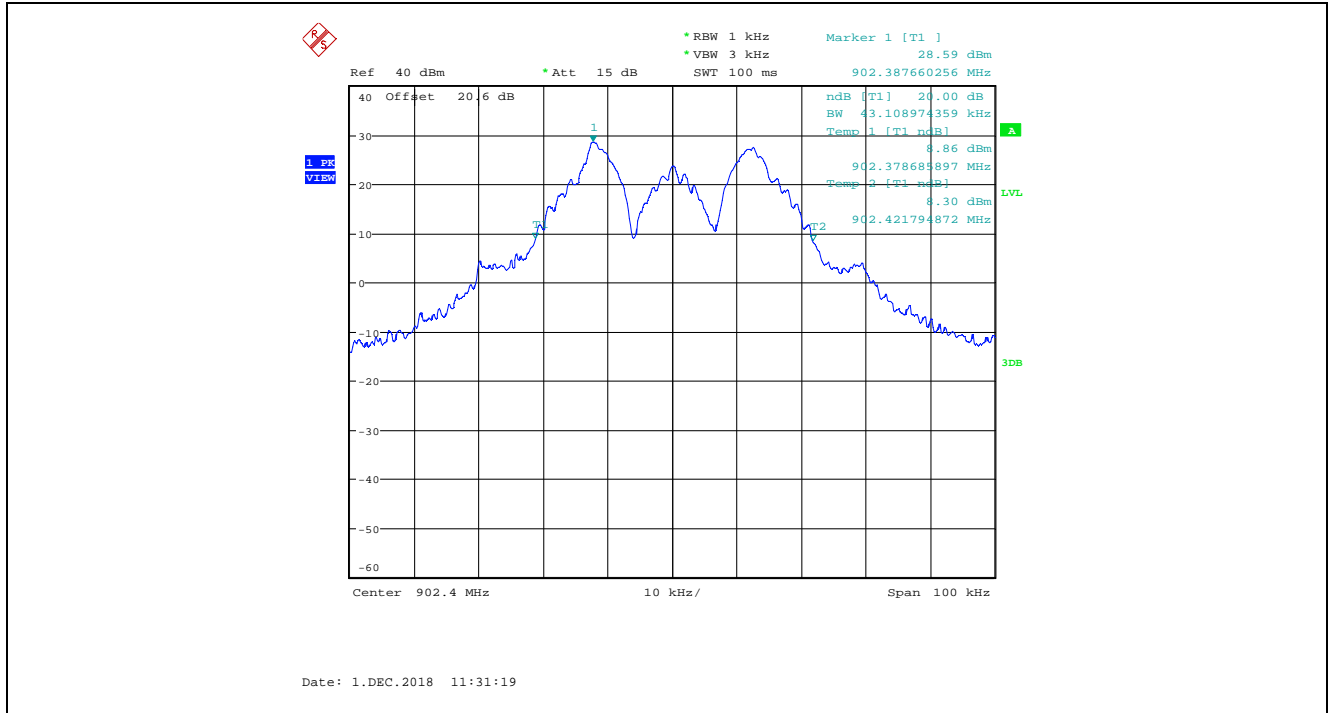

Plot 5.3.4.2. 20 dB Bandwidth, 915 MHz, Low Data Rate, 100 kHz CS, High Power, Raw Power Setting at 10

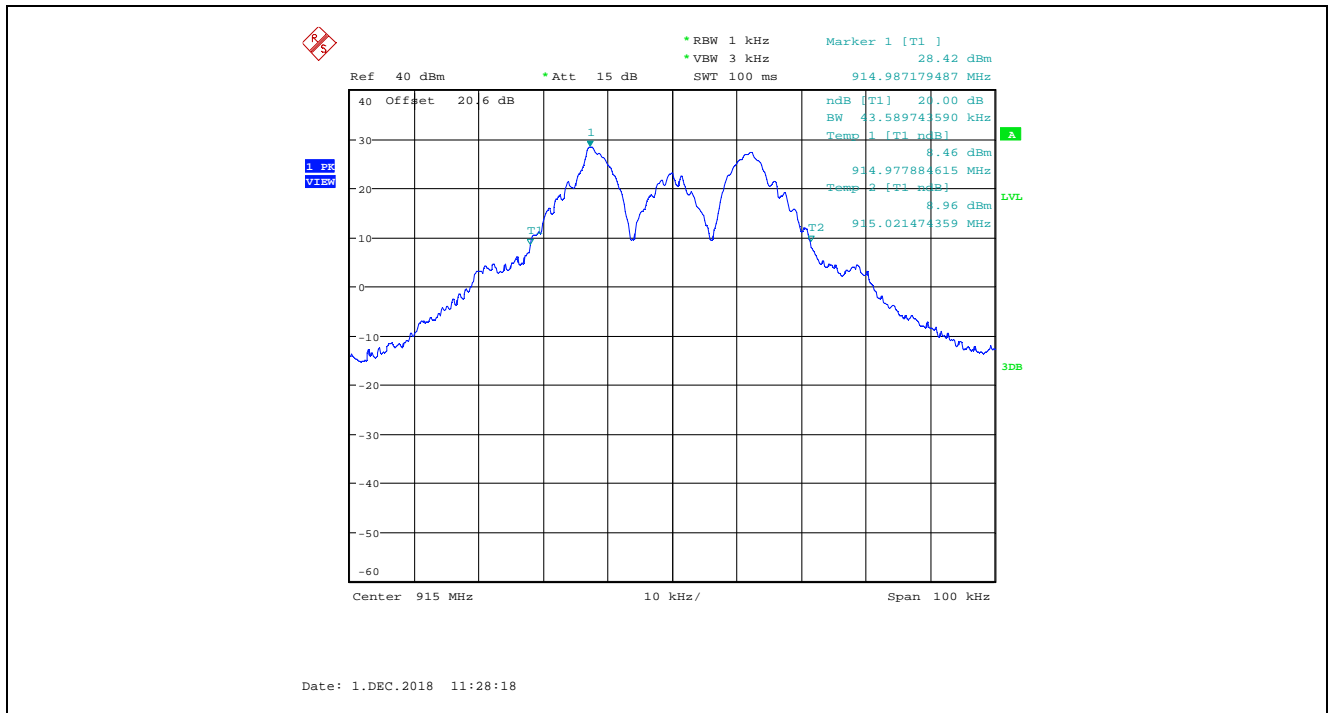



Plot 5.3.4.5. 20 dB Bandwidth, 914.9 MHz, Middle Data Rate, 250 kHz CS, High Power, Raw Power Setting at 10

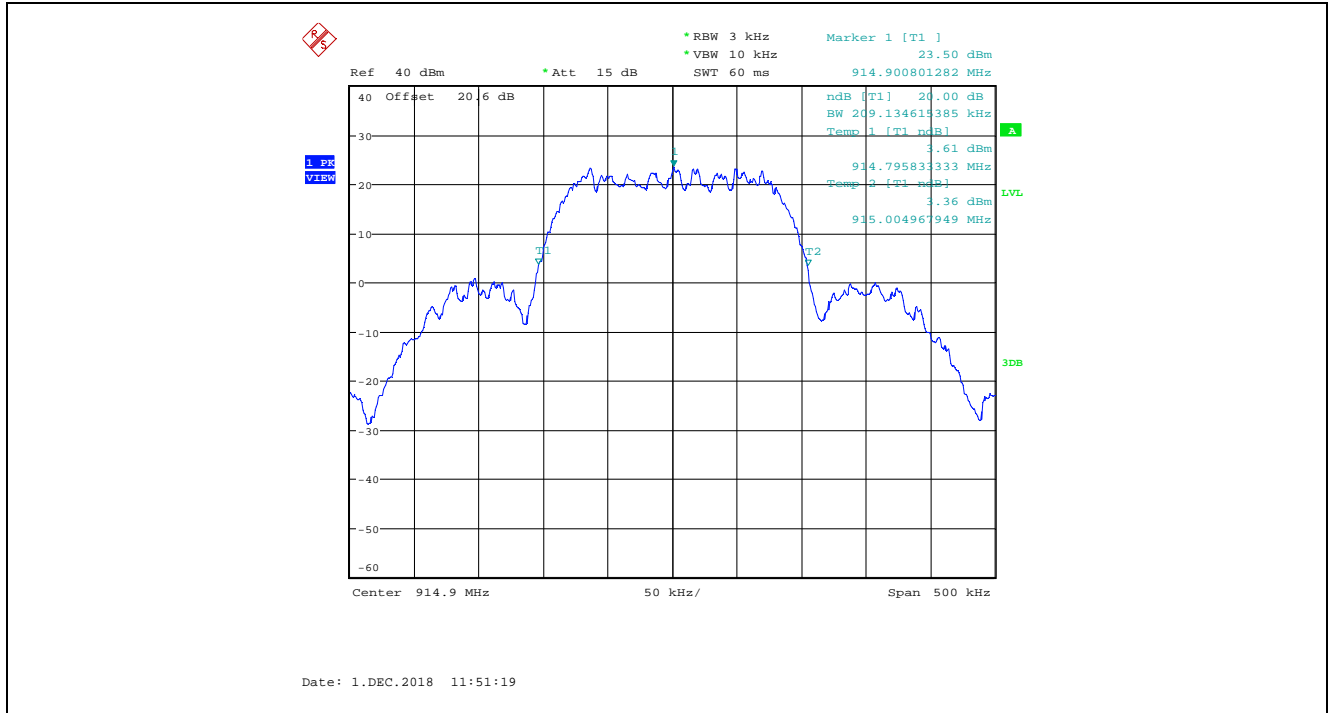

Plot 5.3.4.6. 20 dB Bandwidth, 927.65 MHz, Middle Data Rate, 250 kHz CS, High Power, Raw Power Setting at 10

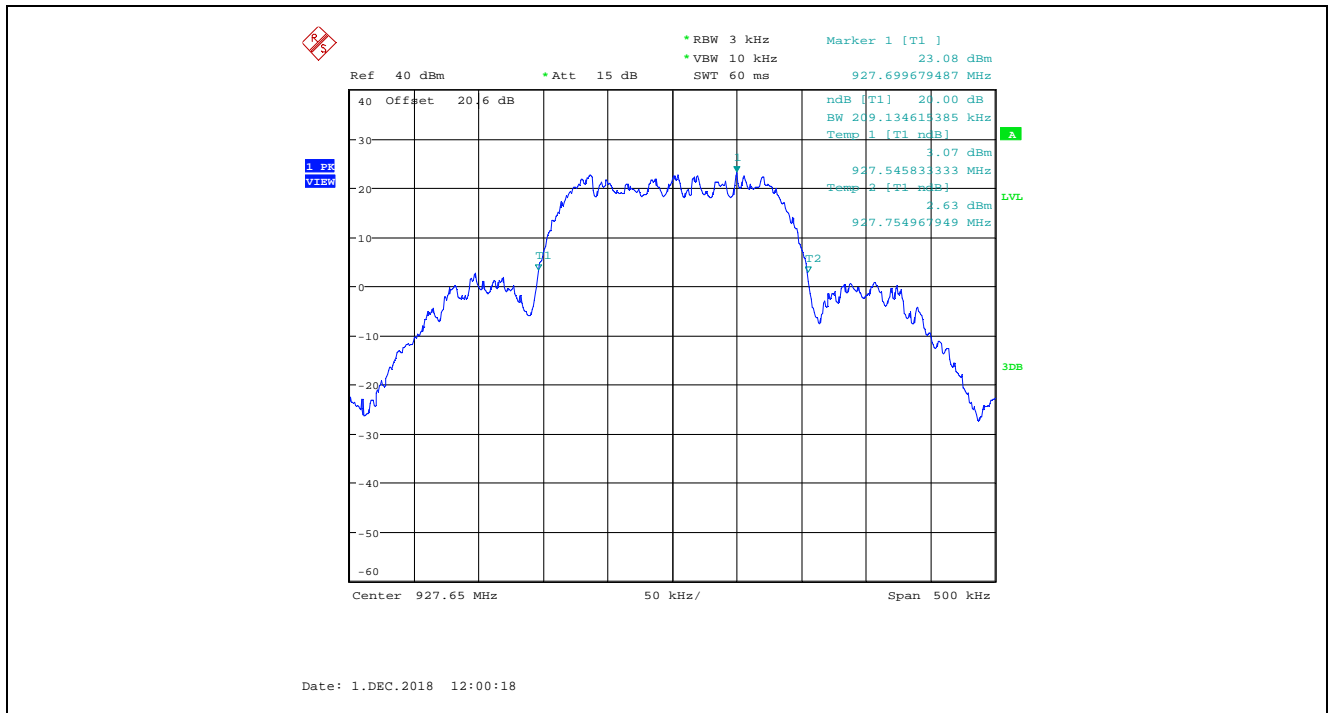

Plot 5.3.4.7. 20 dB Bandwidth, 903.0 MHz, High Data Rate, 500 kHz CS, High Power, Raw Power Setting at 10

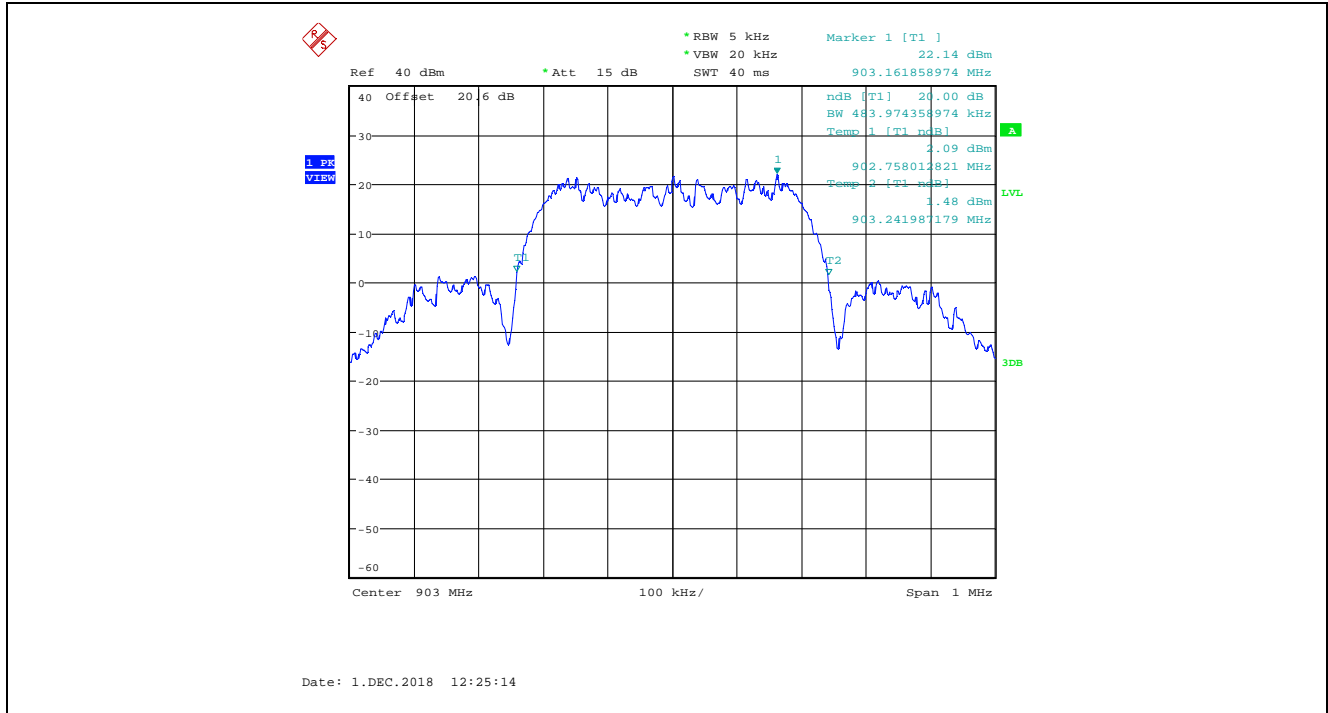

Plot 5.3.4.8. 20 dB Bandwidth, 915.0 MHz, High Data Rate, 500 kHz CS, High Power, Raw Power Setting at 10

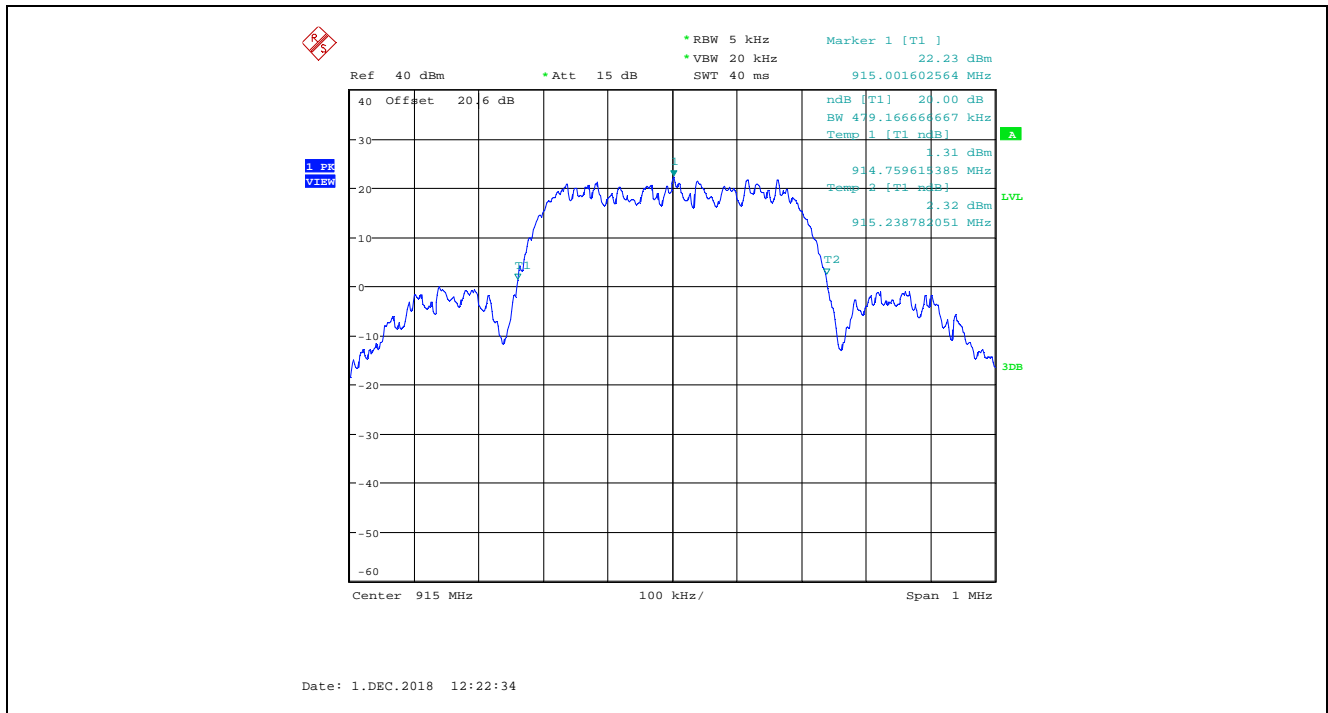

Plot 5.3.4.9. 20 dB Bandwidth, 927.5 MHz, High Data Rate, 500 kHz CS, High Power, Raw Power Setting at 10

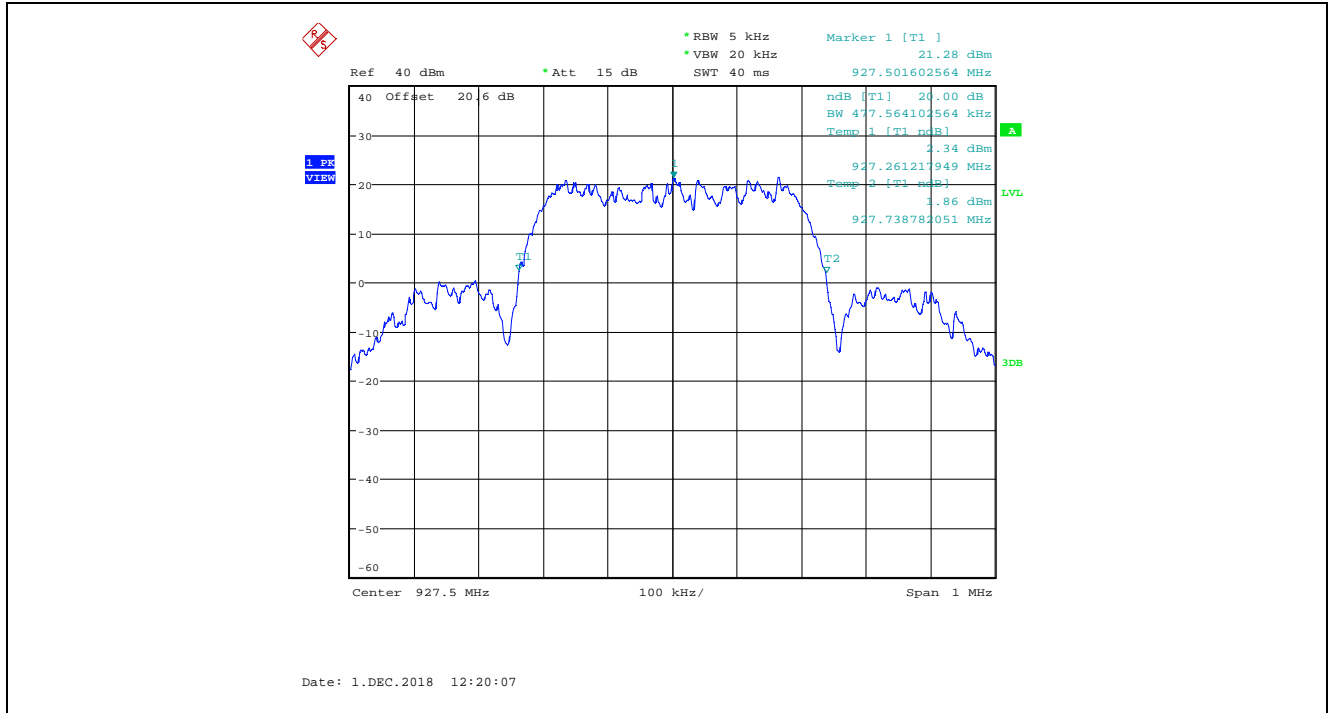

Plot 5.3.4.10. Carrier Frequency Separation, Low Data Rate, 100 kHz CS

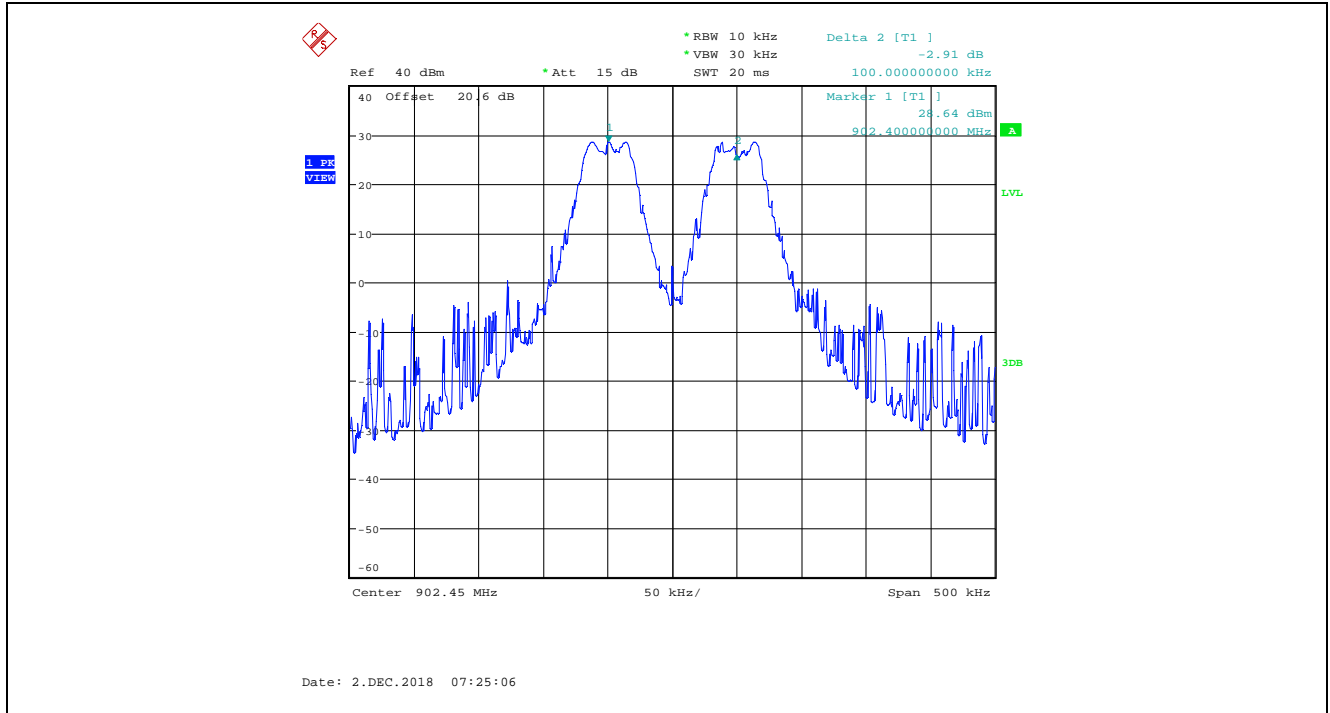

Plot 5.3.4.11. Carrier Frequency Separation, Middle Data Rate, 250 kHz CS

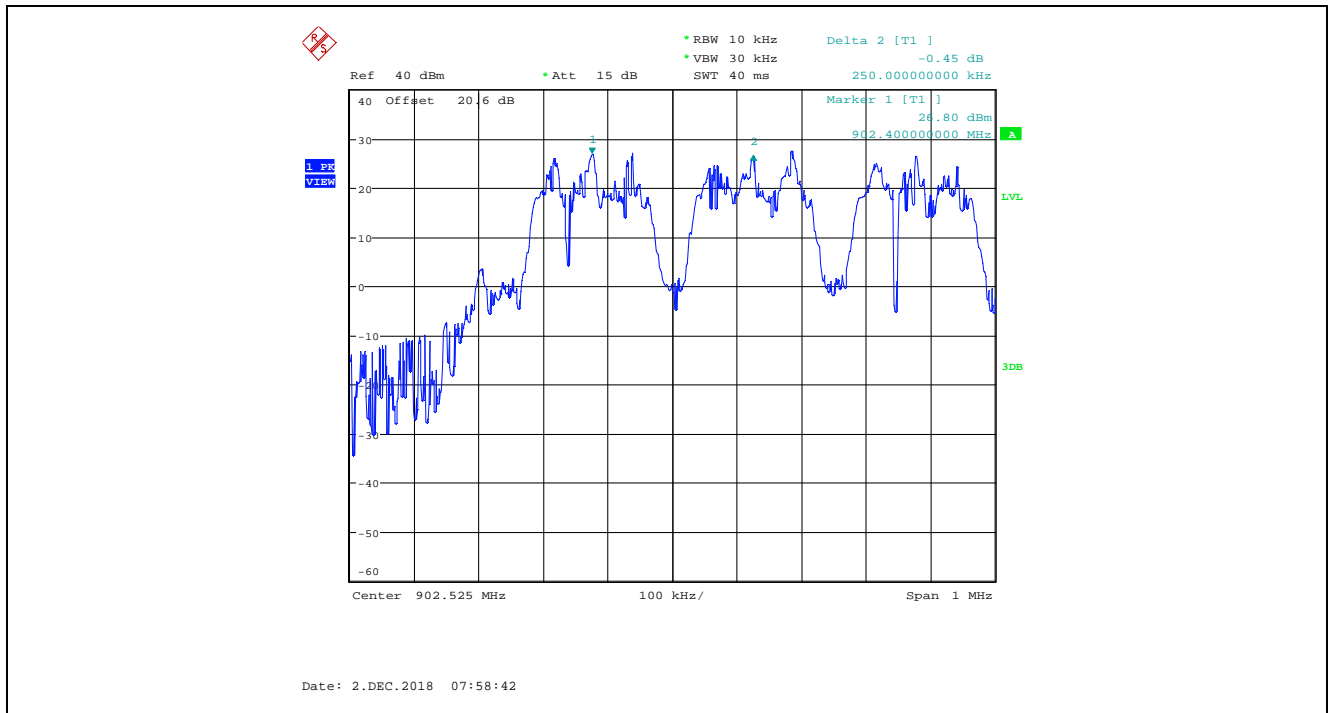

Plot 5.3.4.12. Carrier Frequency Separation, High Data Rate, 500 kHz CS

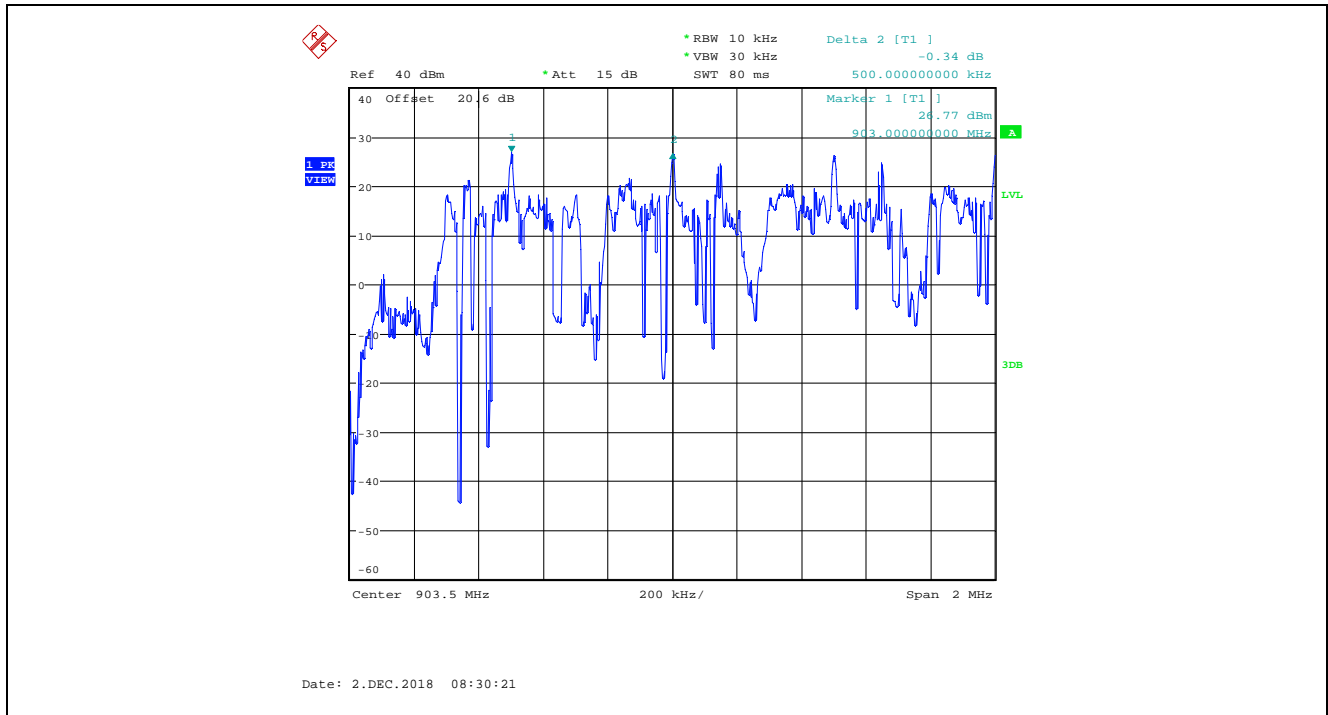



Plot 5.3.4.13. Number of Hopping Frequencies, Low Data Rate, 100 kHz CS  
13 Hopping Channels from 902 - 910 MHz

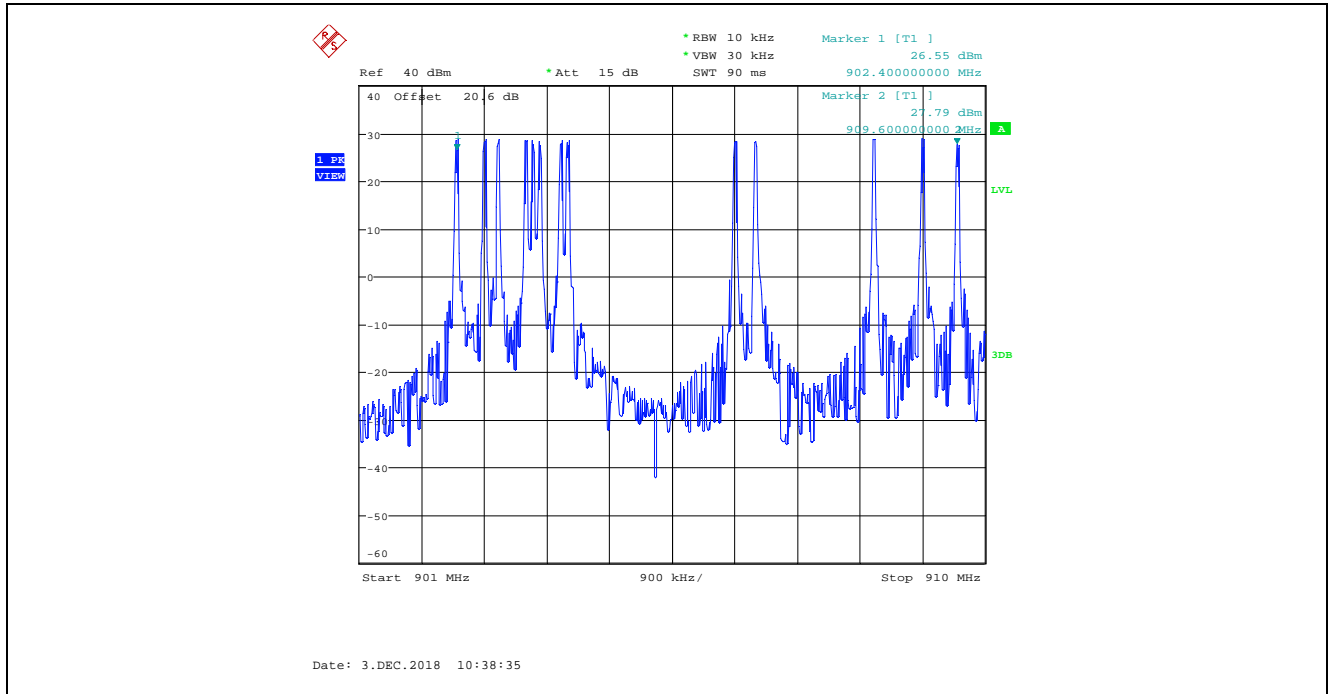

Plot 5.3.4.14. Number of Hopping Frequencies, Low Data Rate, 100 kHz CS  
19 Hopping Channel from 910 - 920 MHz

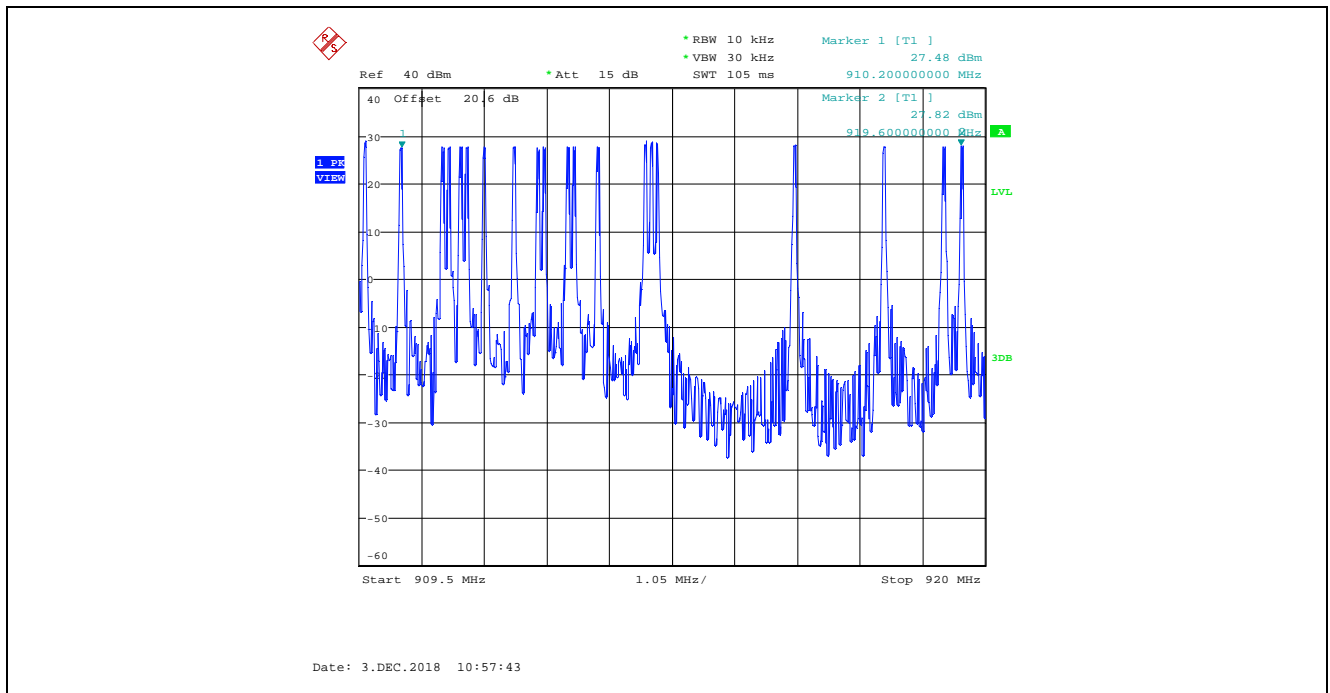

**Plot 5.3.4.15.** Number of Hopping Frequencies, Low Data Rate, 100 kHz CS  
 18 Hopping Channels from 920 - 928 MHz

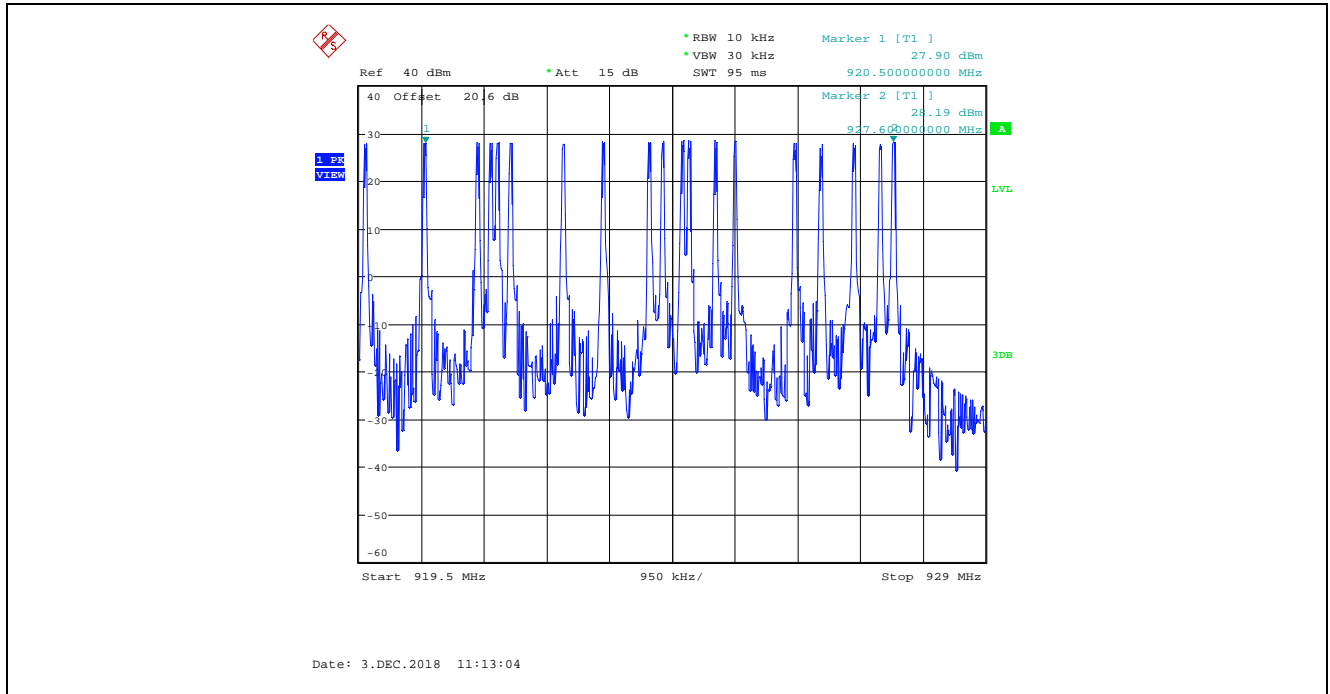

**Plot 5.3.4.16.** Number of Hopping Frequencies, Low Data Rate, 100 kHz CS  
 The Total Number of Hopping Channel in 902 – 928 MHz Band is 50 (13 + 19 + 18)

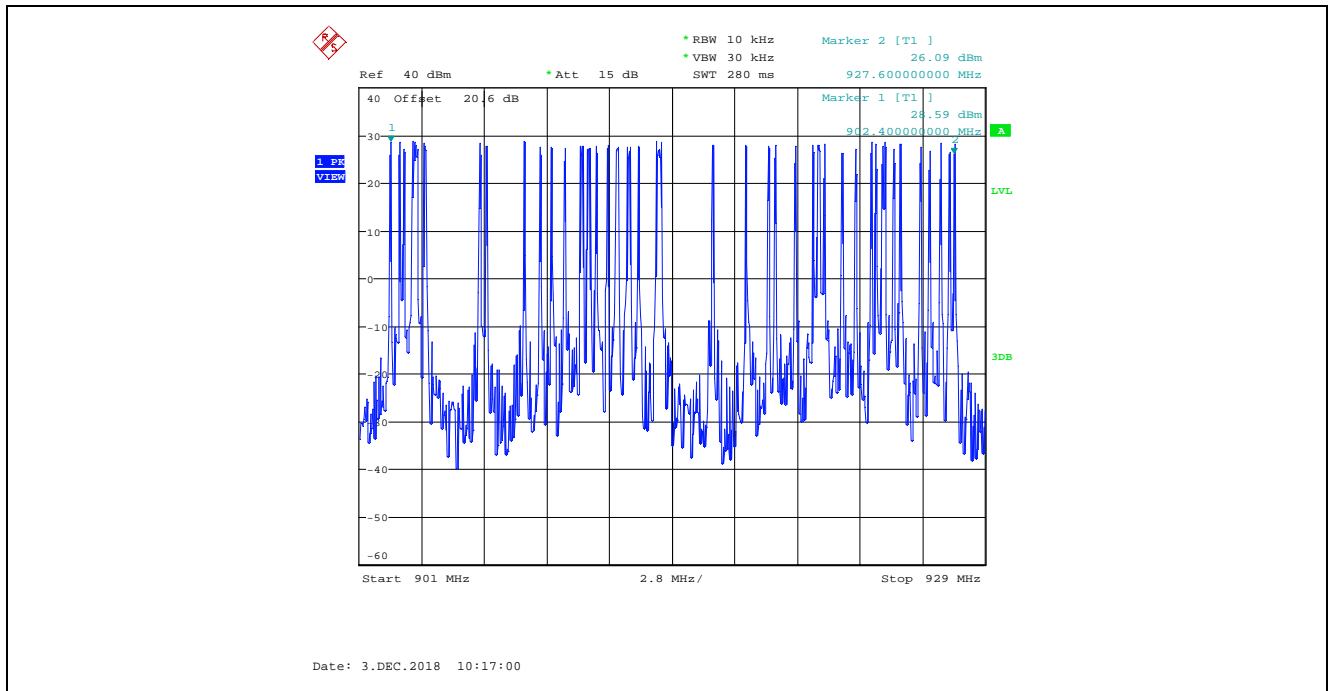

Plot 5.3.4.17. Number of Hopping Frequencies, Middle Data Rate, 250 kHz CS  
 11 Hopping Channels from 902 – 910 MHz

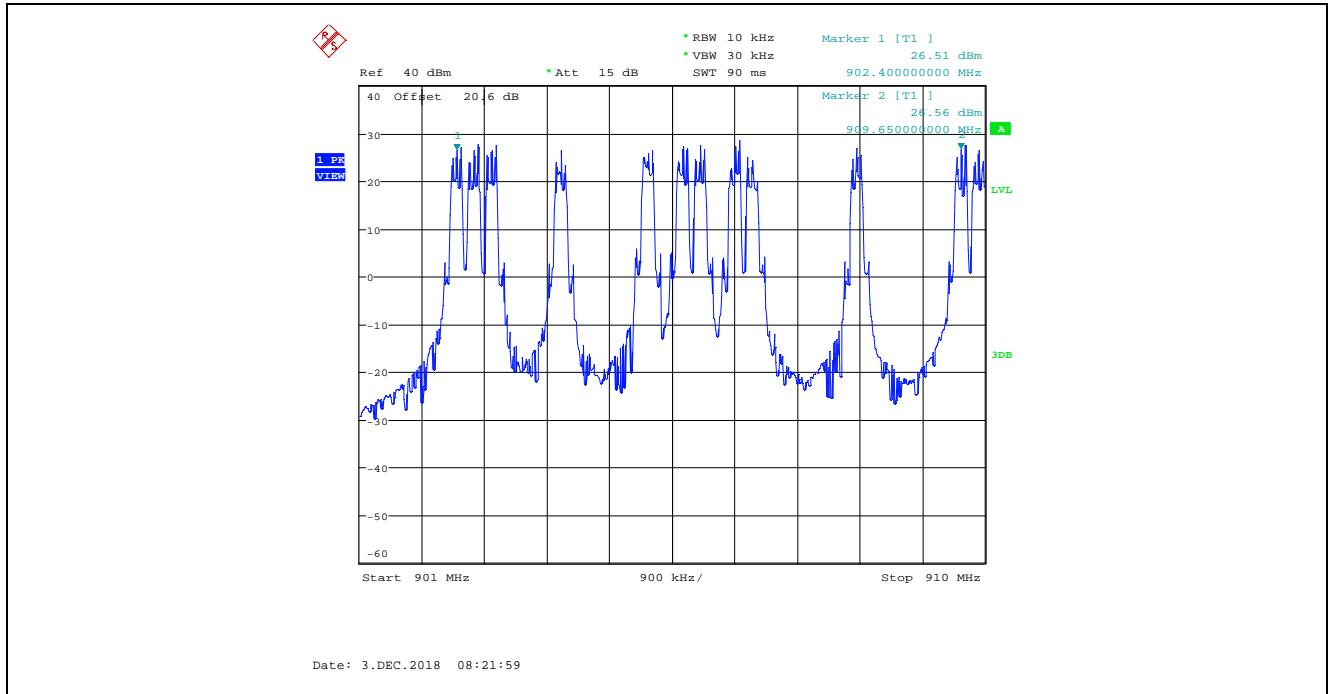

Plot 5.3.4.18. Number of Hopping Frequencies, Middle Data Rate, 250 kHz CS  
 22 Hopping Channels from 910 – 920 MHz

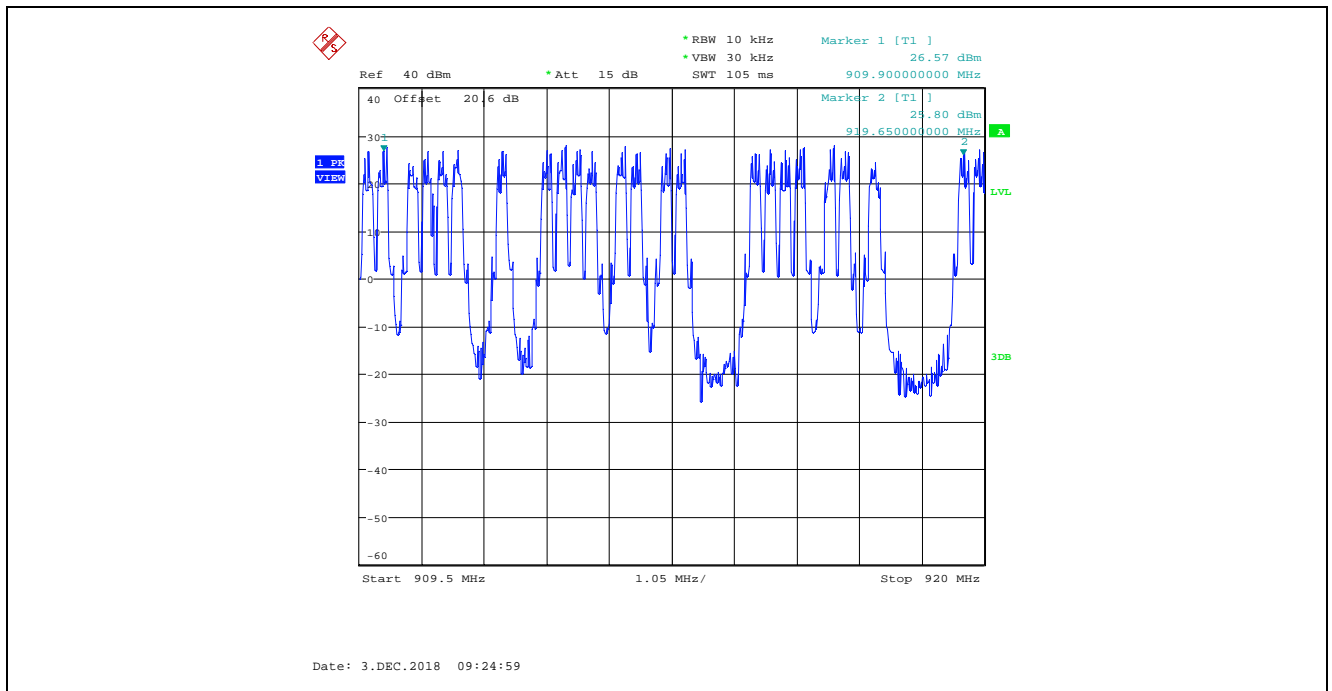

**Plot 5.3.4.19.** Number of Hopping Frequencies, Middle Data Rate, 250 kHz CS  
 17 Hopping Channels from 920 - 928 MHz

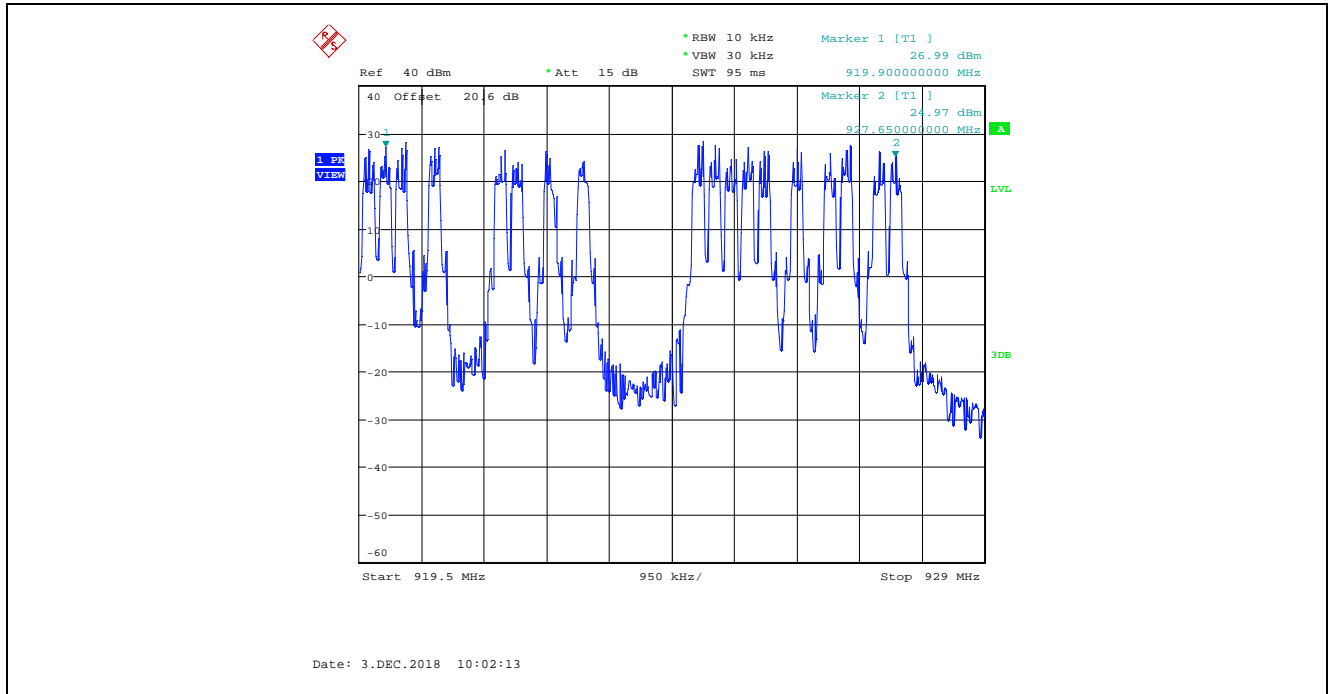

**Plot 5.3.4.20.** Number of Hopping Frequencies, Middle Data Rate, 250 kHz CS  
 The Total Number of Hopping Channel in 902 – 928 MHz Band is 50 (11 + 22 + 17)

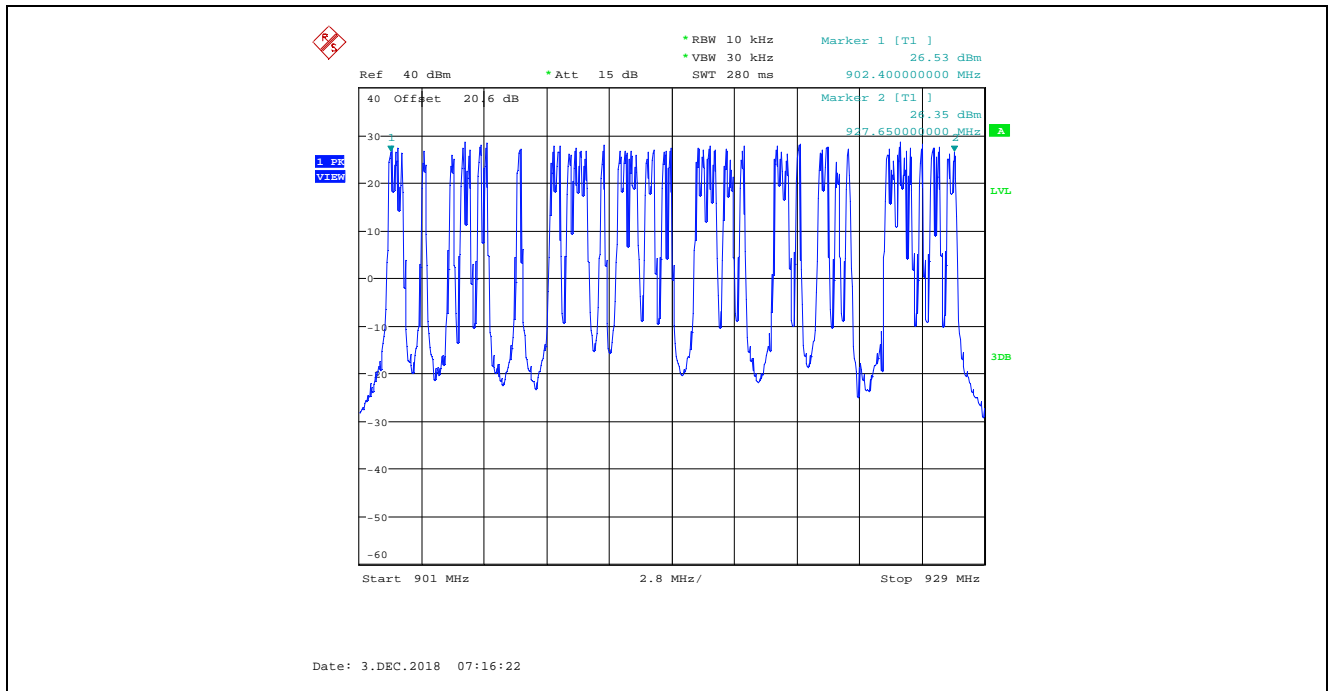

Plot 5.3.4.21. Number of Hopping Frequencies, High Data Rate, 500 kHz CS  
14 Hopping Channels from 902 - 910 MHz

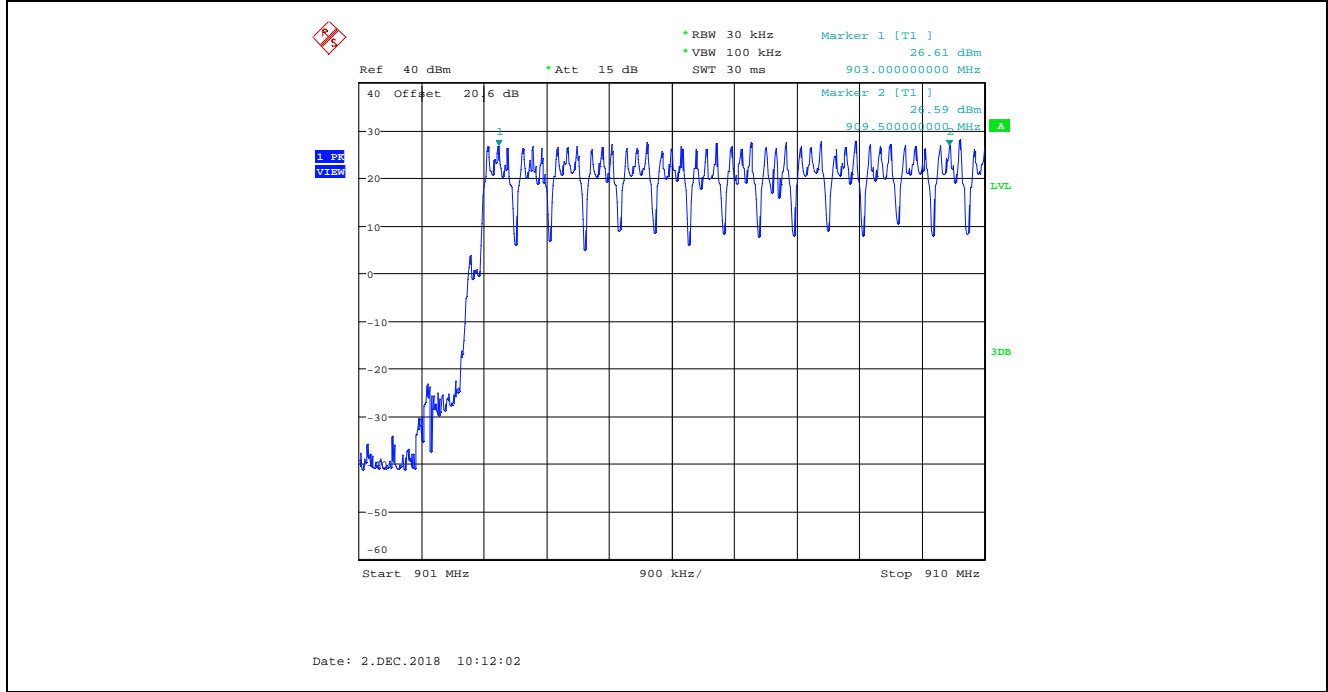

Plot 5.3.4.22. Number of Hopping Frequencies, High Data Rate, 500 kHz CS  
20 Hopping Channels from 910 - 920 MHz

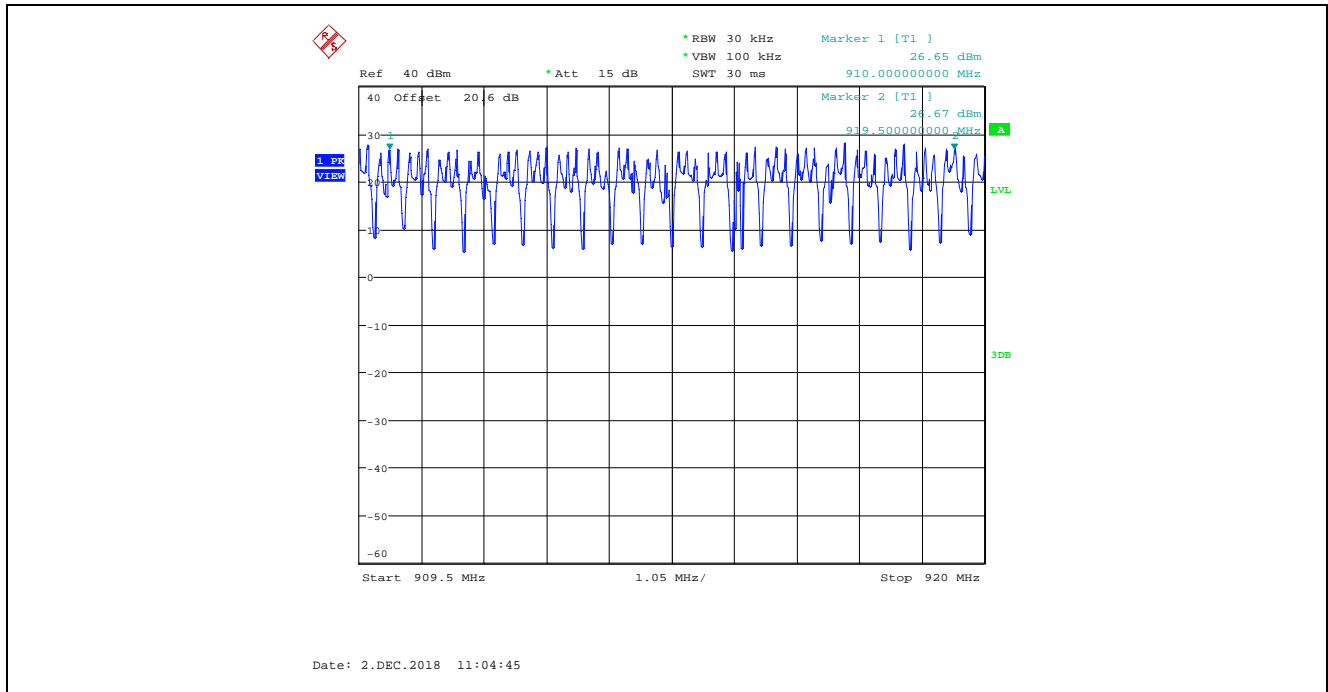

**Plot 5.3.4.23.** Number of Hopping Frequencies, High Data Rate, 500 kHz CS  
 16 Hopping Channels from 920 - 928 MHz

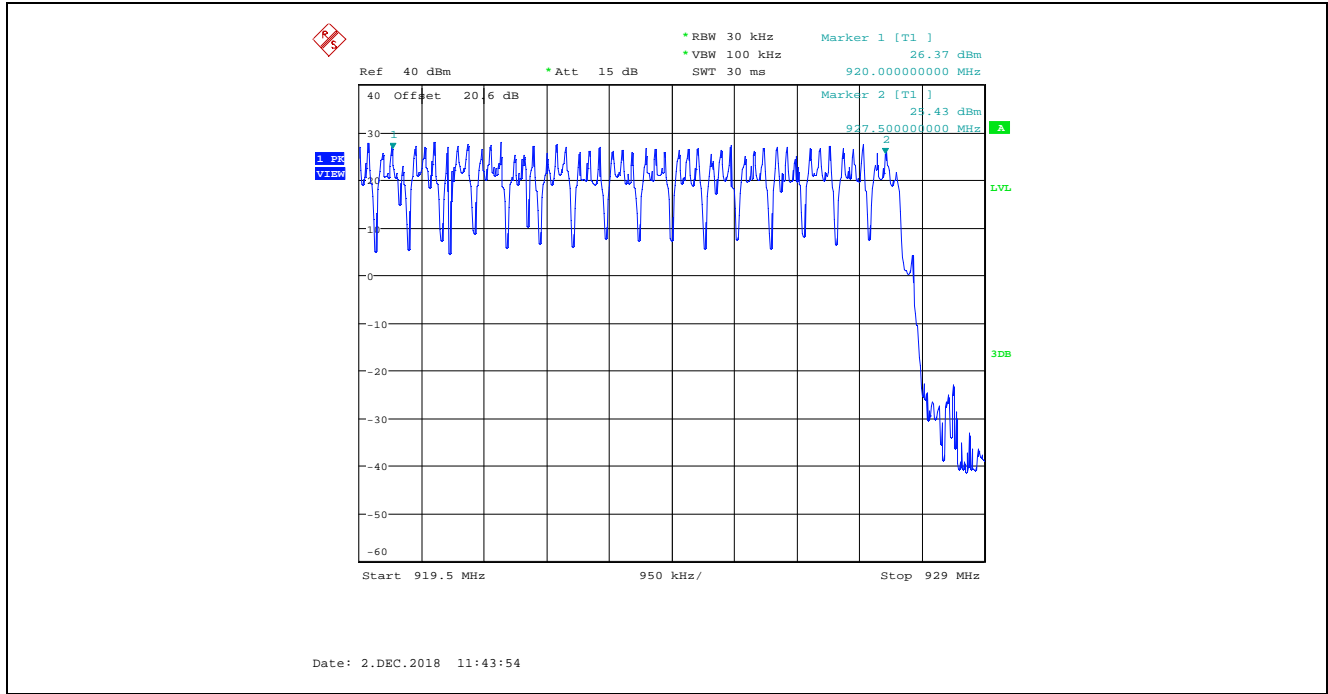

**Plot 5.3.4.24.** Number of Hopping Frequencies, High Data Rate, 500 kHz CS  
 The Total Number of Hopping Channel in 902 – 928 MHz Band is 50 (14 + 20 + 16)



**Plot 5.3.4.25.** Time of Occupancy, 902.4 MHz, Low Data Rate, 100 kHz CS  
 Dwell Time at 902.4 MHz = 11.35 ms

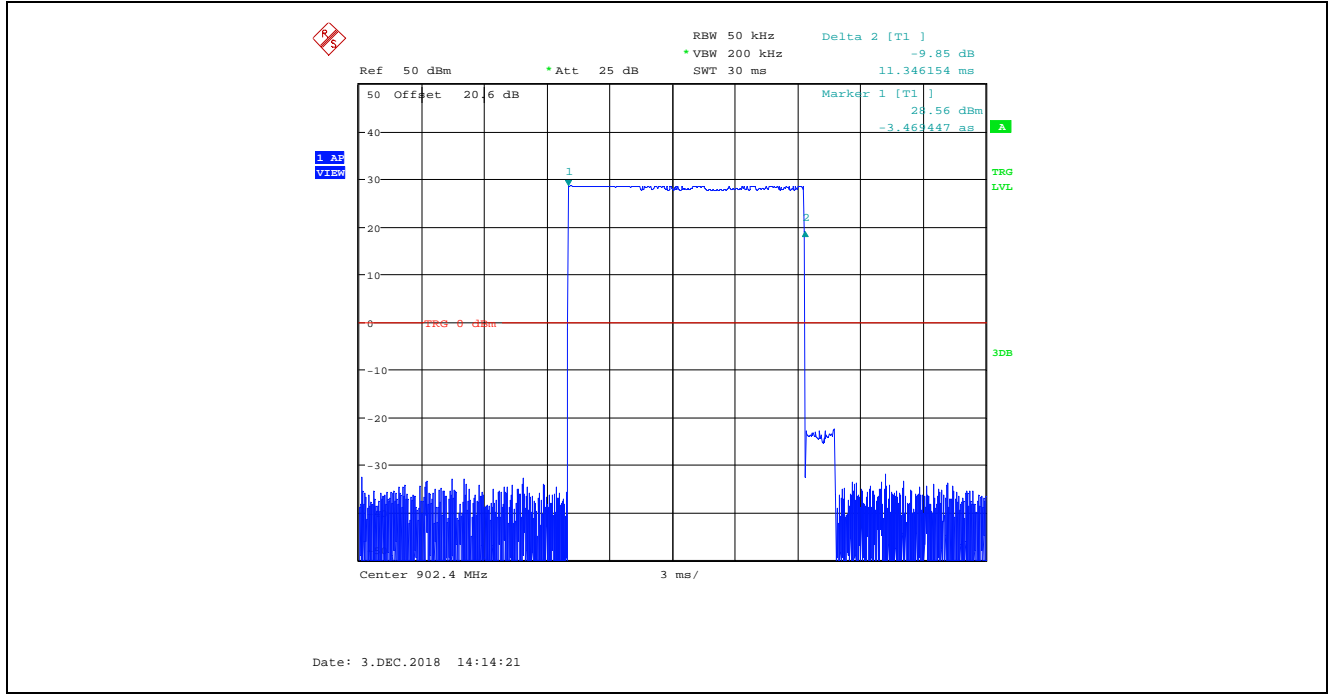

**Plot 5.3.4.26.** Time of Occupancy, 902.4 MHz, Low Data Rate, 100 kHz CS  
 Average time of occupancy = (Dwell Time) x (number of hops within a 20s period) = 11.35 ms x 7 = 79.45 ms

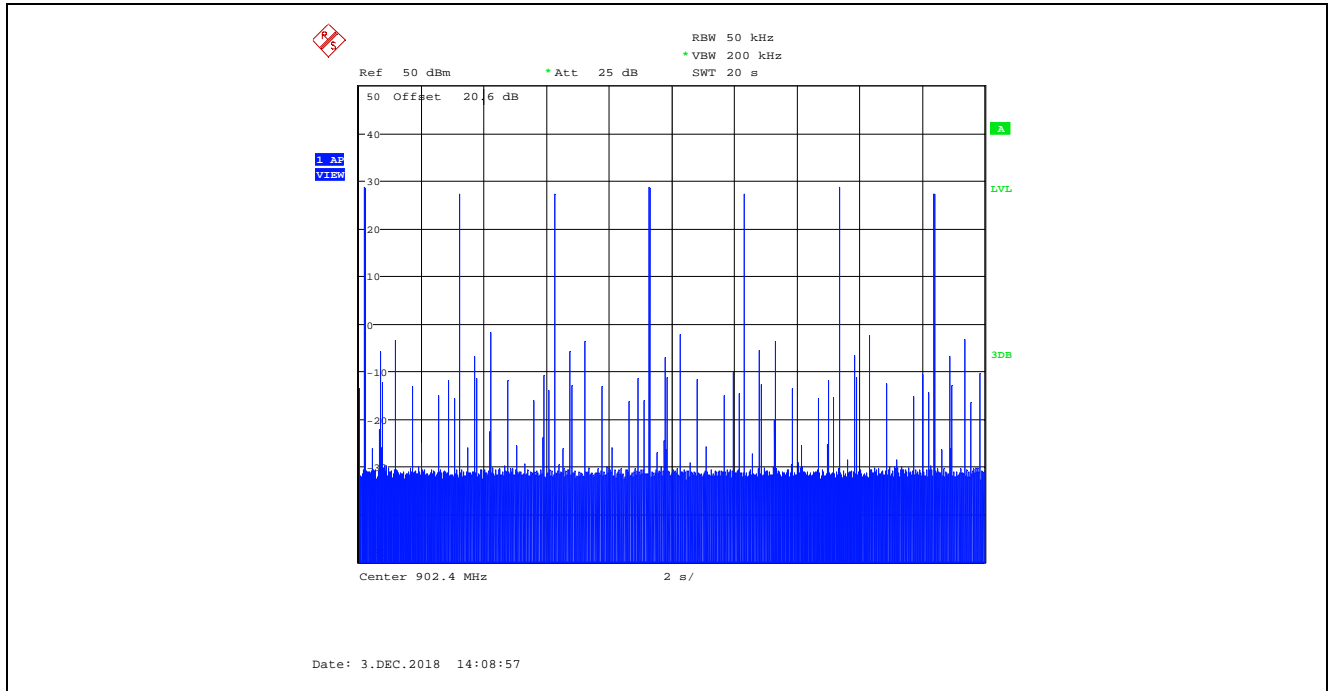

**Plot 5.3.4.27.** Time of Occupancy, 915.0 MHz, Low Data Rate, 100 kHz CS  
 Dwell Time at 915.0 MHz = 11.35 ms

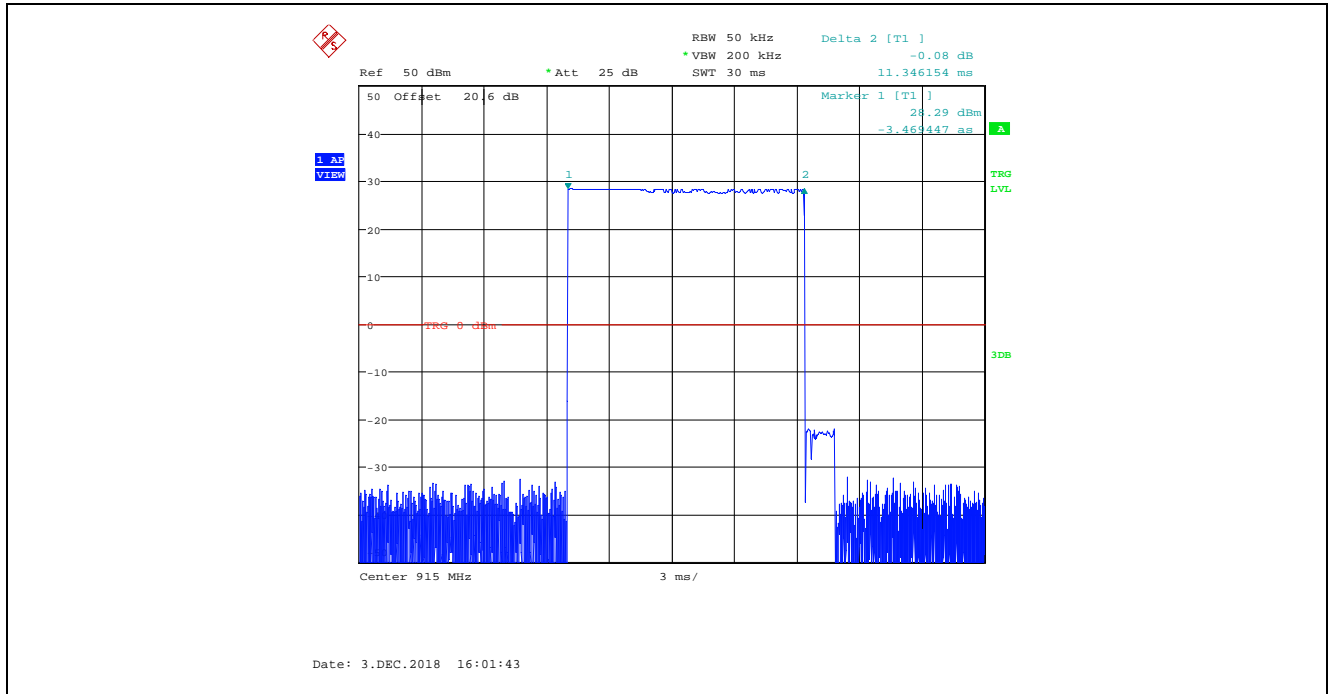

**Plot 5.3.4.28.** Time of Occupancy, 915.0 MHz, Low Data Rate, 100 kHz CS  
 Average time of occupancy = (Dwell Time) x (number of hops within a 20s period) = 11.35 ms x 7 = 79.45 ms

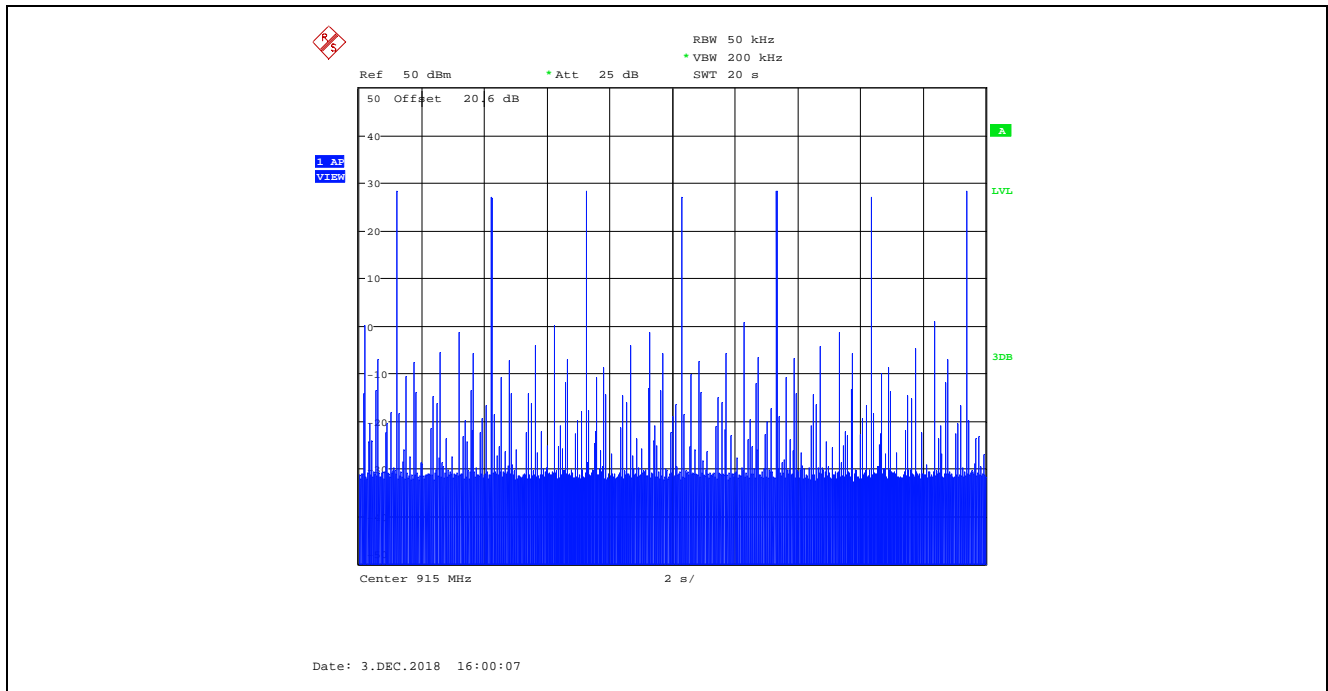



**Plot 5.3.4.29.** Time of Occupancy, 927.6 MHz, Low Data Rate, 100 kHz CS  
Dwell Time at 927.6 MHz = 11.35 ms

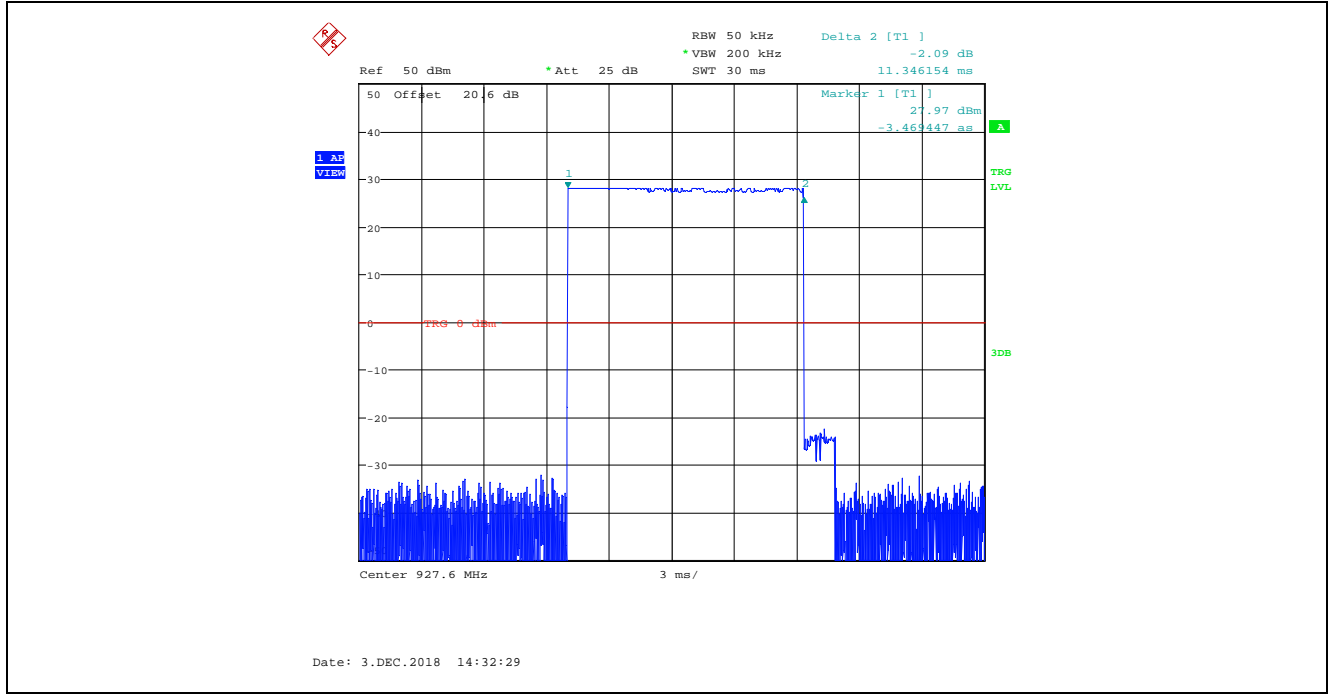

**Plot 5.3.4.30.** Time of Occupancy, 927.6 MHz, Low Data Rate, 100 kHz CS  
Average time of occupancy = (Dwell Time) x (number of hops within a 20s period) = 11.35 ms x 7 = 79.45 ms

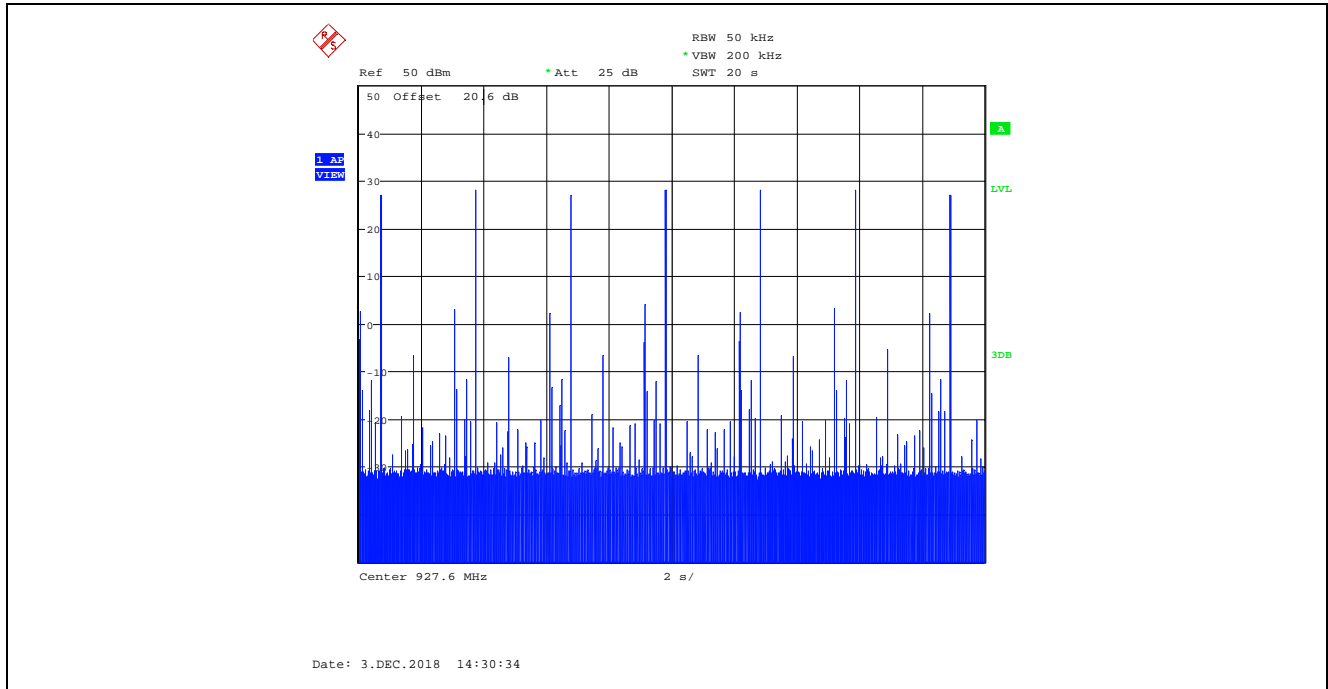

**Plot 5.3.4.31.** Time of Occupancy, 902.4 MHz, Middle Data Rate, 250 kHz CS  
 Dwell Time at 902.4 MHz = 1.39 ms

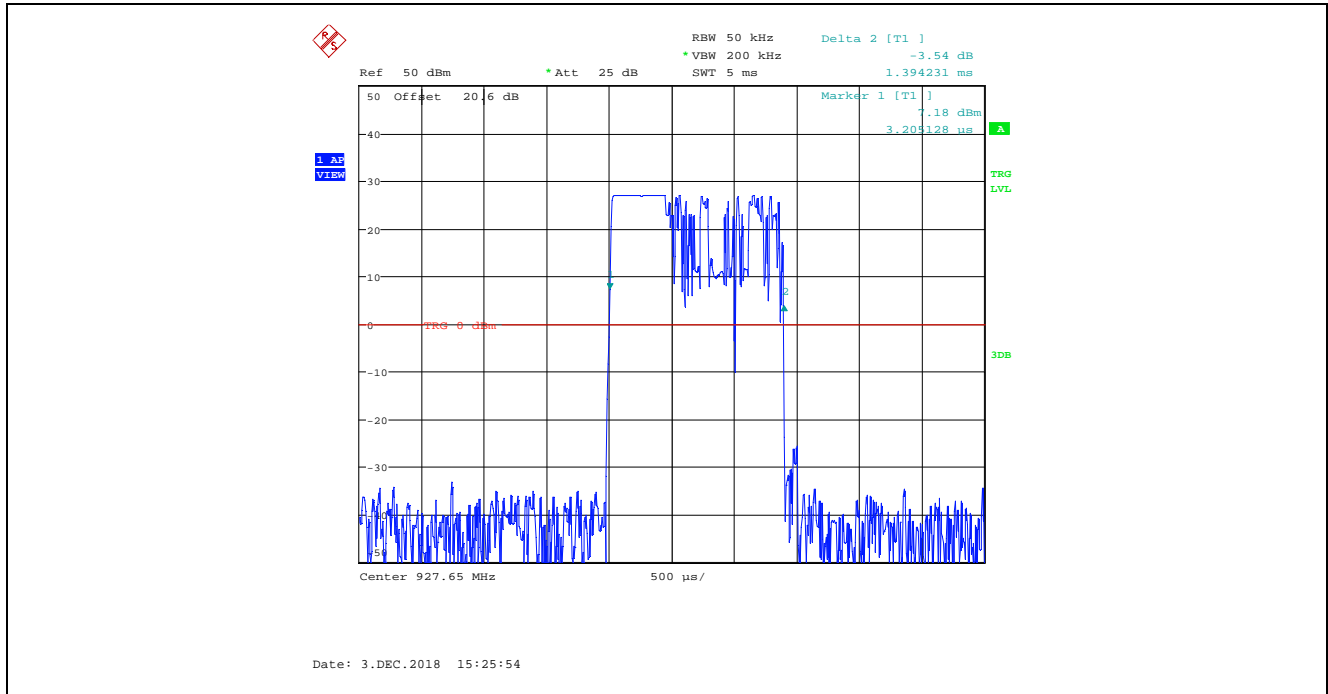

**Plot 5.3.4.32.** Time of Occupancy, 902.4 MHz, Middle Data Rate, 250 kHz CS  
 Average time of occupancy = (Dwell Time) x (number of hops within a 10s period) = 1.39 ms x 4 = 5.56 ms

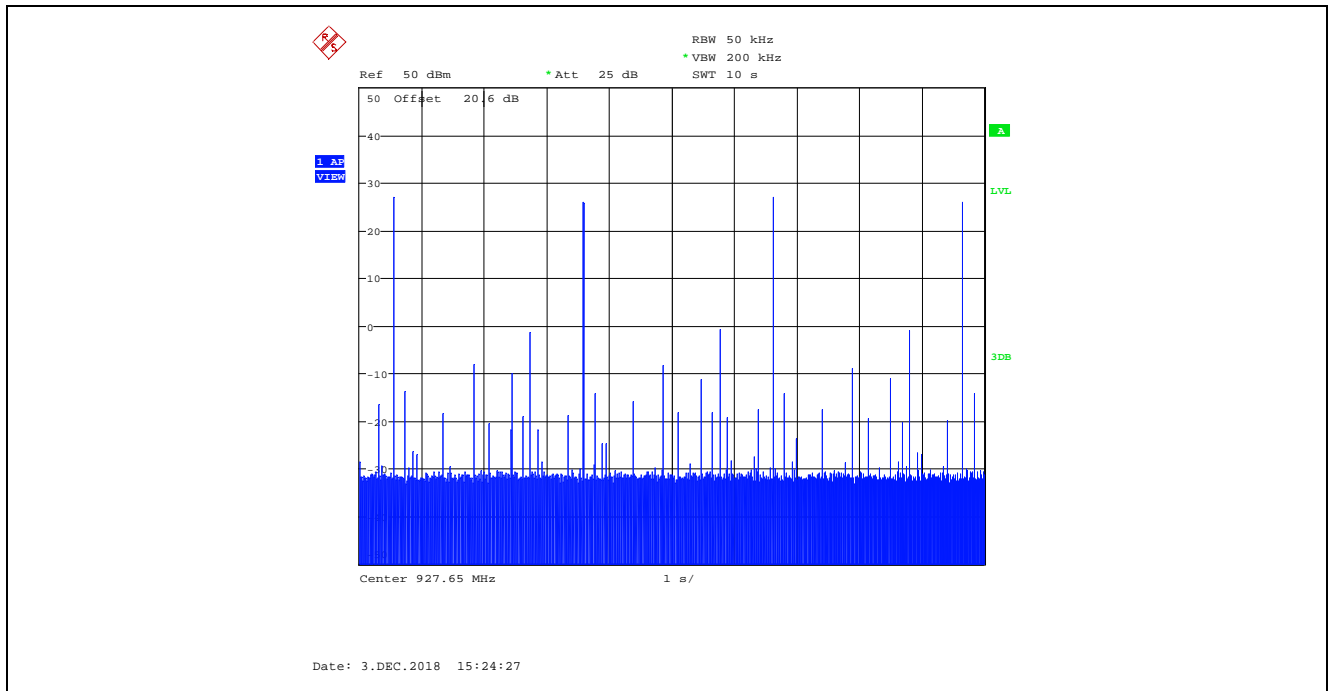

Plot 5.3.4.33. Time of Occupancy, 914.9 MHz, Middle Data Rate, 250 kHz CS  
Dwell Time at 914.9 MHz = 1.39 ms

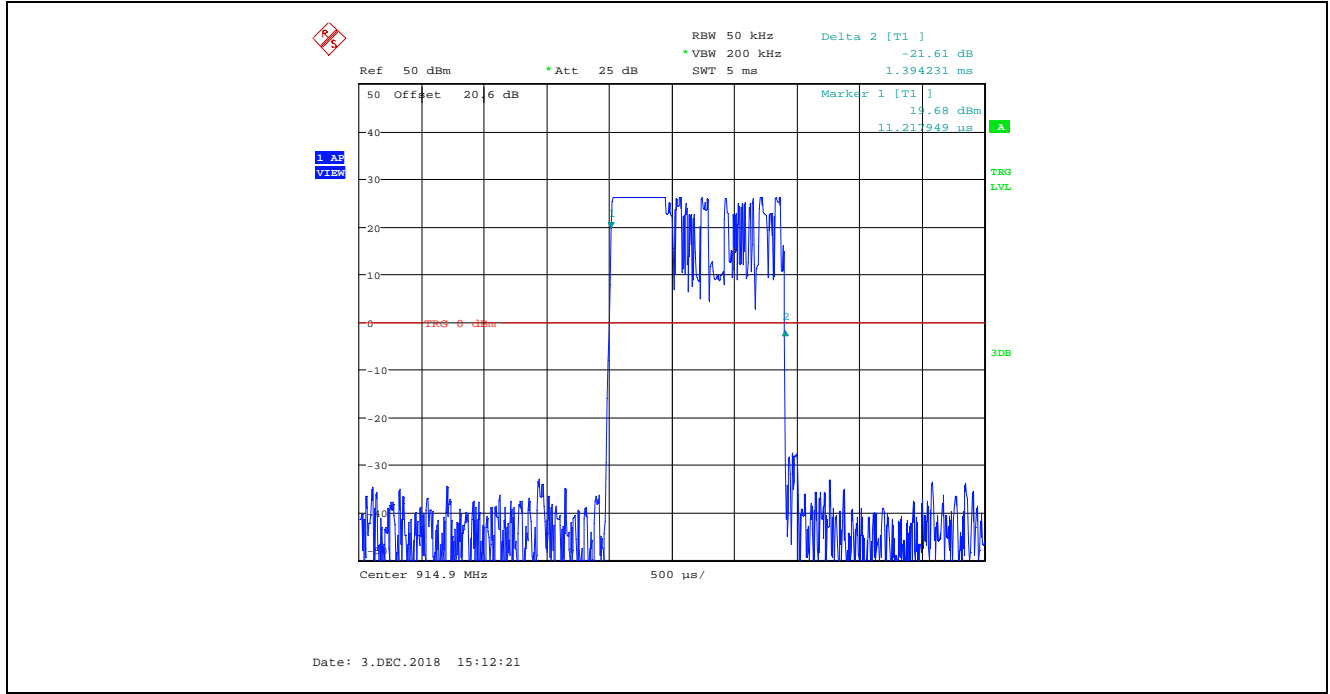

Plot 5.3.4.34. Time of Occupancy, 914.9 MHz, Middle Data Rate, 250 kHz CS  
Average time of occupancy = (Dwell Time) x (number of hops within a 10s period) = 1.39 ms x 4 = 5.56 ms

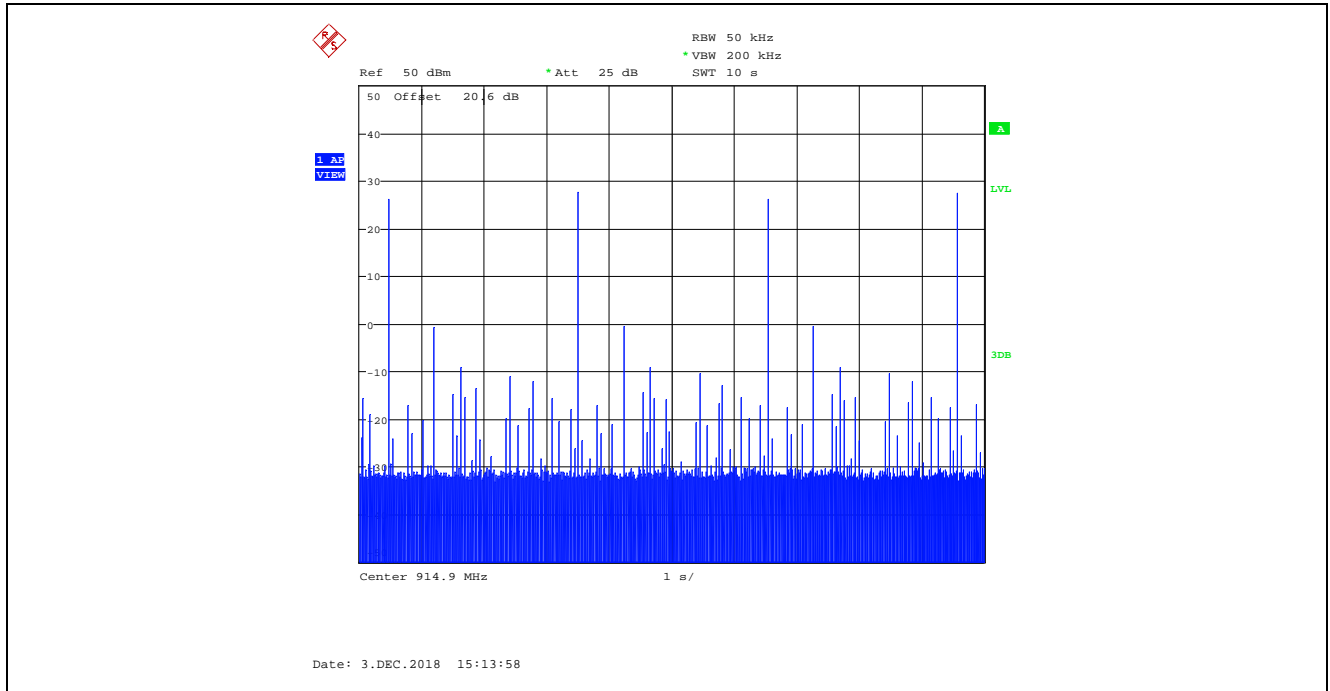

**Plot 5.3.4.35.** Time of Occupancy, 927.65 MHz, Middle Data Rate, 250 kHz CS  
 Dwell Time at 927.65 MHz = 1.39 ms

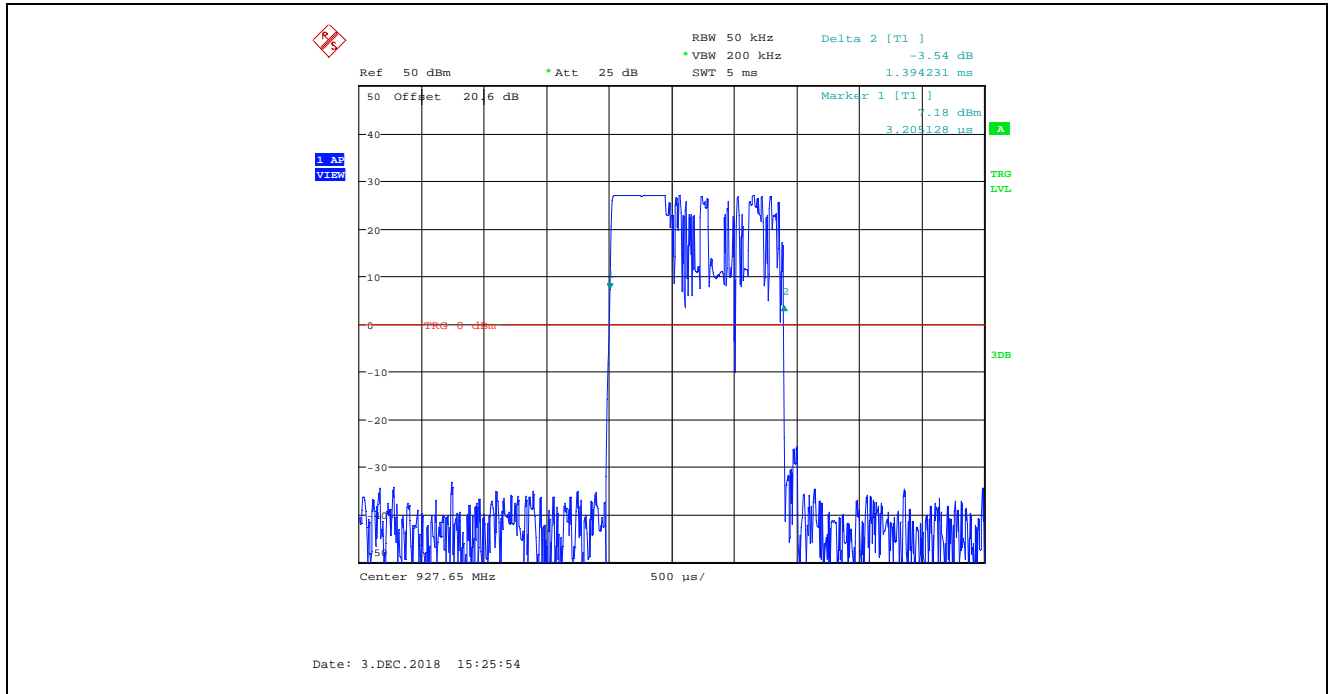

**Plot 5.3.4.36.** Time of Occupancy, 927.65 MHz, Middle Data Rate, 250 kHz CS  
 Average time of occupancy = (Dwell Time) x (number of hops within a 10s period) = 1.39 ms x 4 = 5.56 ms

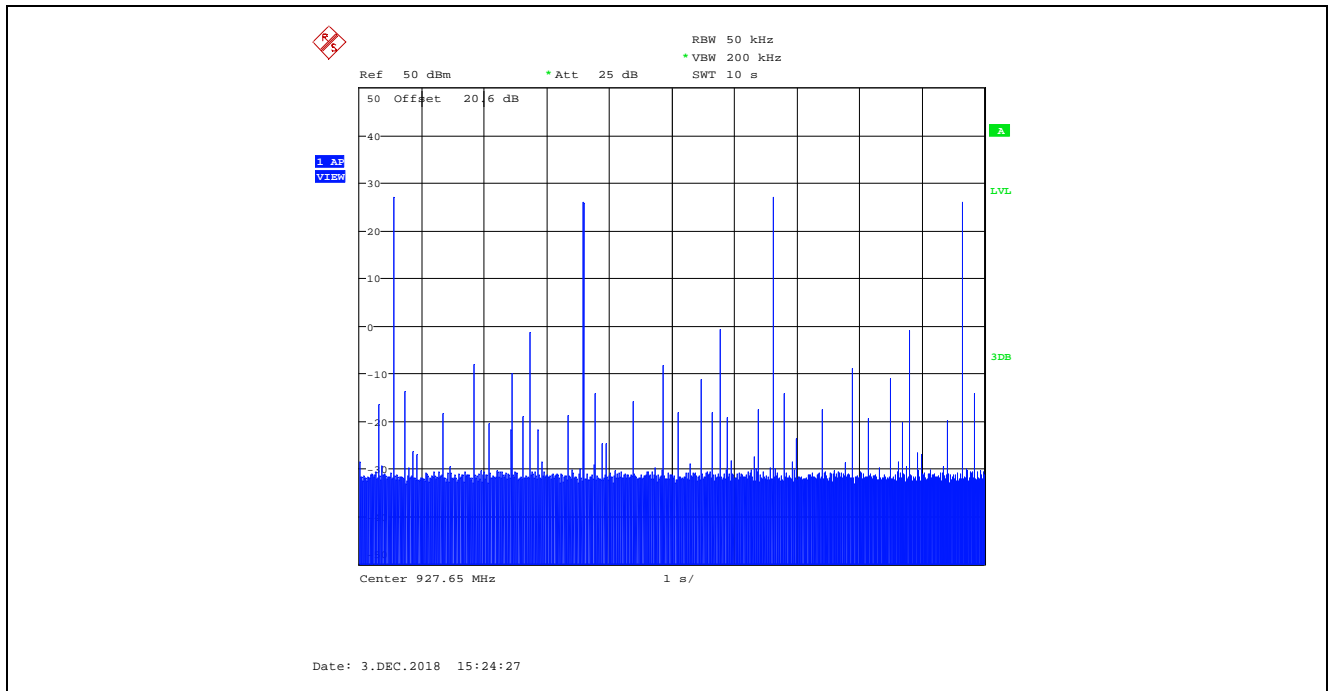

**Plot 5.3.4.37.** Time of Occupancy, 903.0 MHz, High Data Rate, 500 kHz CS  
 Dwell Time at 903.0 MHz = 798.08 μs

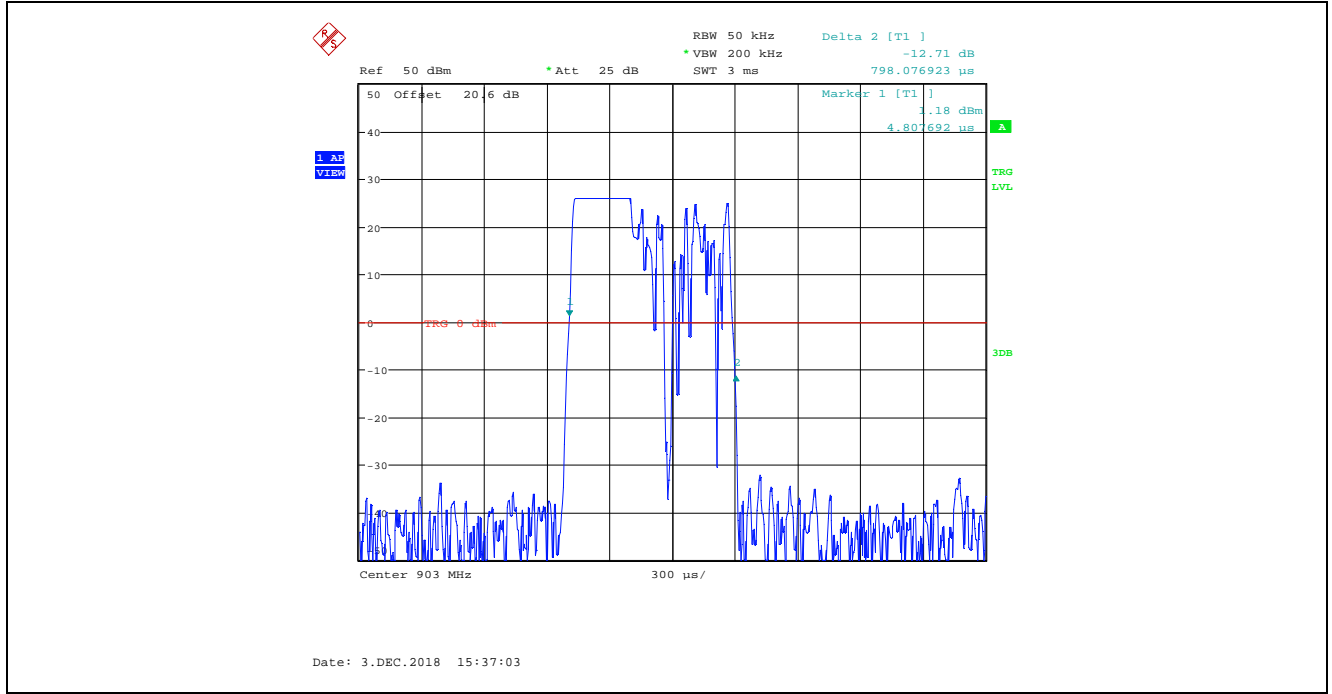

**Plot 5.3.4.38.** Time of Occupancy, 903.0 MHz, High Data Rate, 500 kHz CS  
 Average time of occupancy = (Dwell Time) x (number of hops within a 10s period) = 798.08 μs x 4 = 3.19 ms

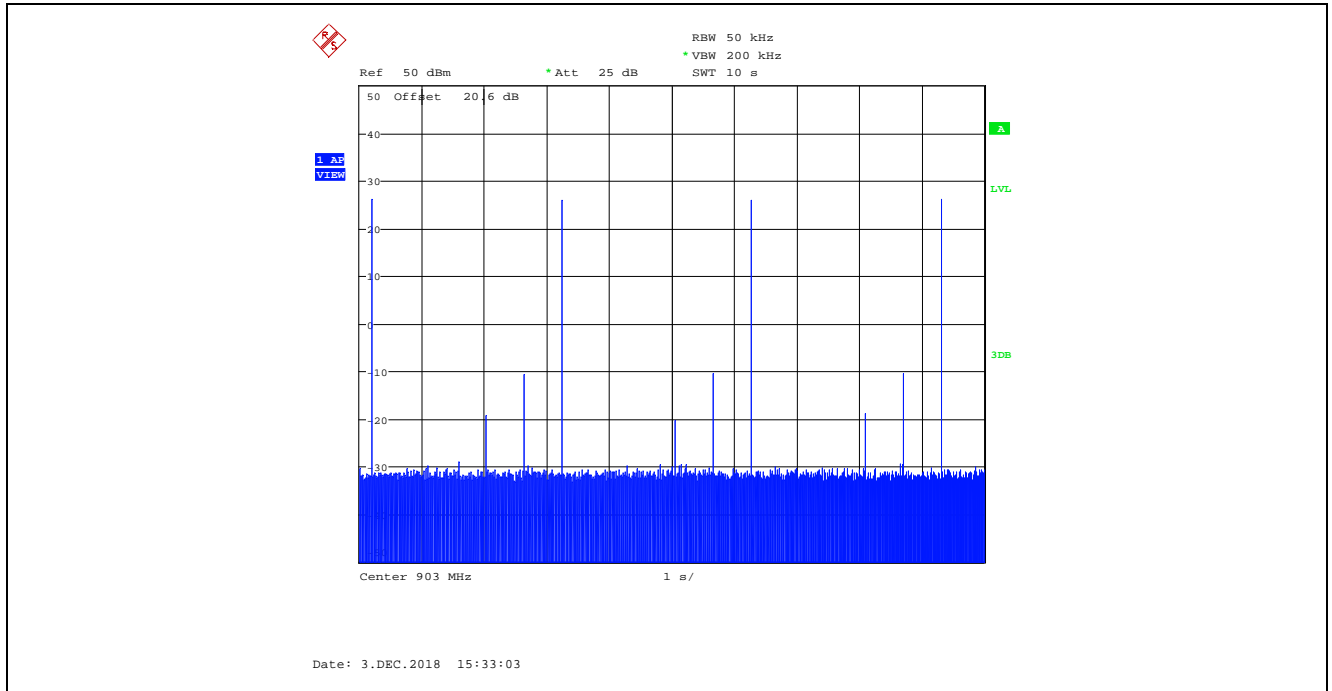

Plot 5.3.4.39. Time of Occupancy, 915.0 MHz, High Data Rate, 500 kHz CS  
Dwell Time at 915.0 MHz = 798.08  $\mu$ s

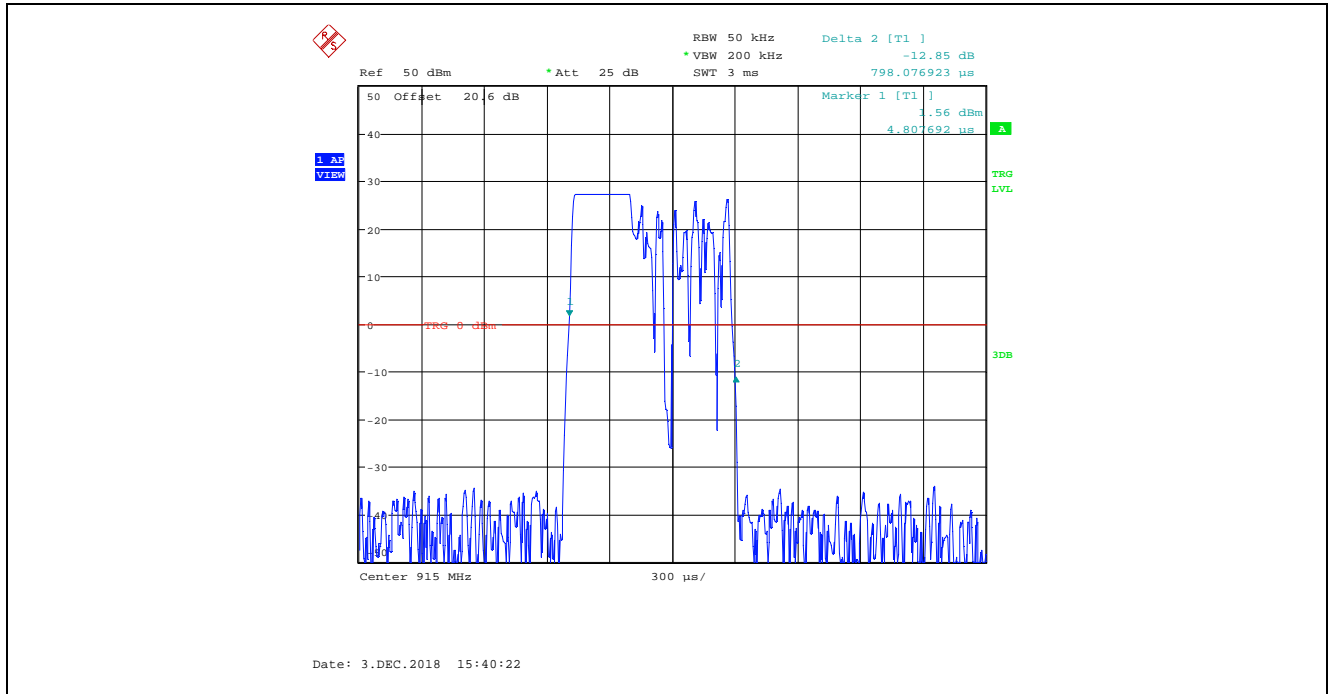

Plot 5.3.4.40. Time of Occupancy, 915.0 MHz, High Data Rate, 500 kHz CS  
Average time of occupancy = (Dwell Time) x (number of hops within a 10s period) = 798.08  $\mu$ s x 4 = 3.19 ms

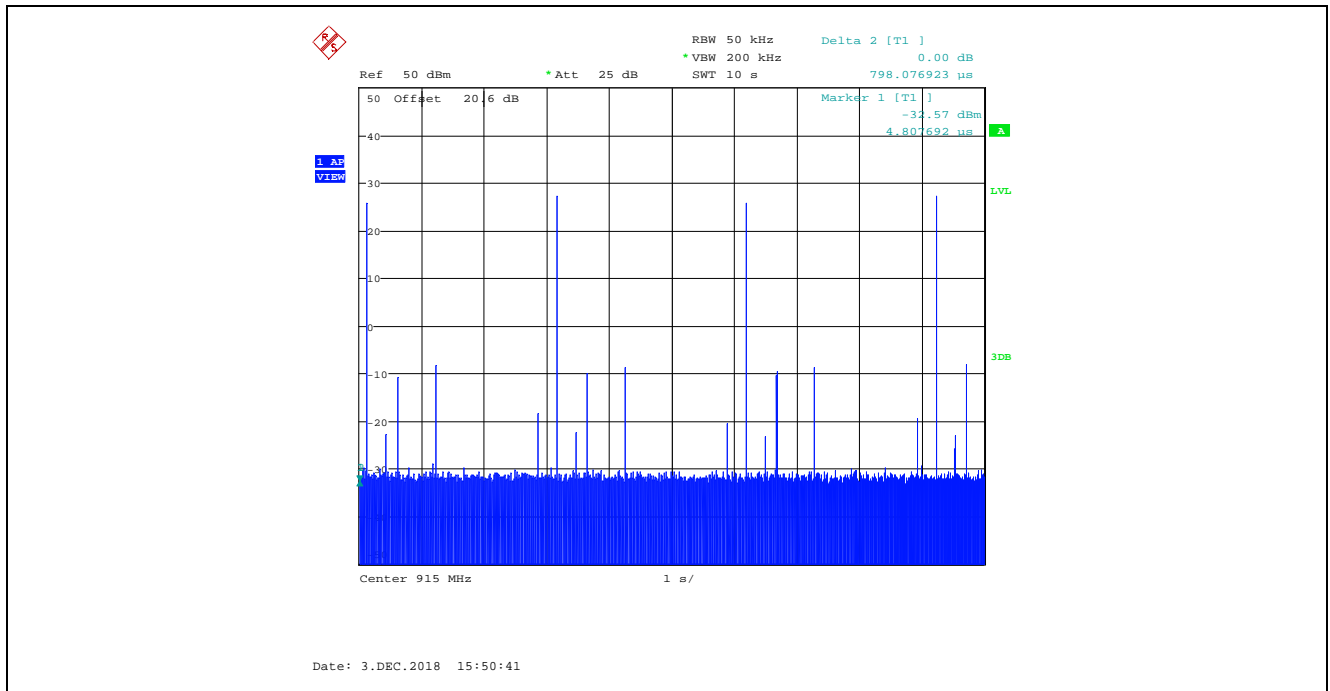

**Plot 5.3.4.41.** Time of Occupancy, 927.5 MHz, High Data Rate, 500 kHz CS  
 Dwell Time at 927.5 MHz = 798.08  $\mu$ s

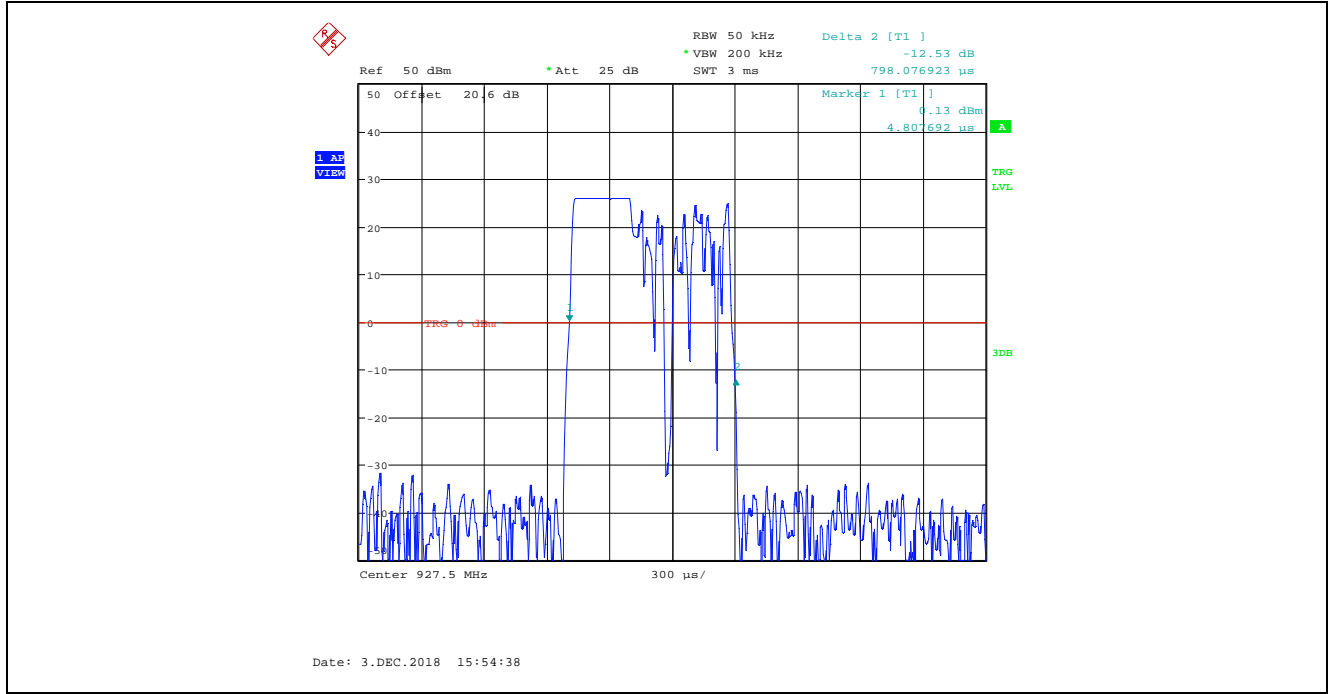

**Plot 5.3.4.42.** Time of Occupancy, 927.5 MHz, High Data Rate, 500 kHz CS  
 Average time of occupancy = (Dwell Time) x (number of hops within a 10s period) = 798.08  $\mu$ s x 4 = 3.19 ms

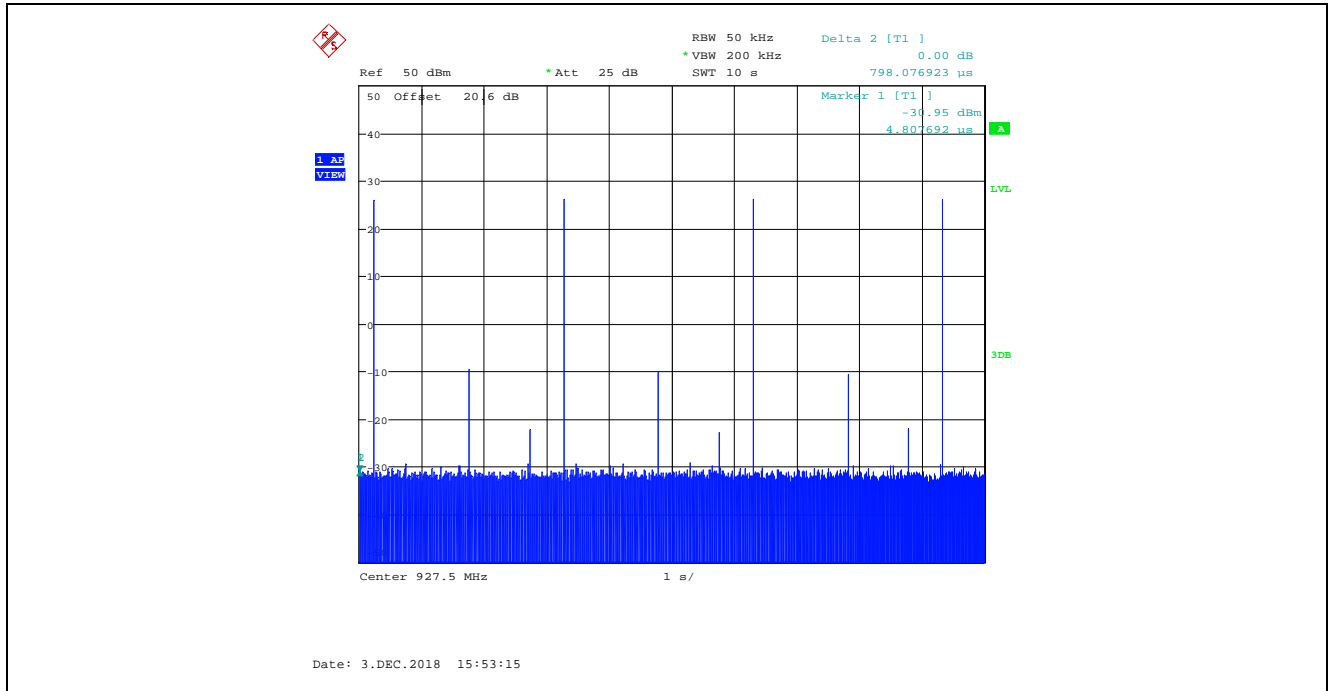

**5.4. PEAK CONDUCTED OUTPUT POWER [§ 15.247(b)(2)]**

**5.4.1. Limits**

**§15.247(b)(2):** For frequency hopping systems operating in the 902-928 MHz band: 1 watt for systems employing at least 50 hopping channels; and, 0.25 watts for systems employing less than 50 hopping channels, but at least 25 hopping channels, as permitted under paragraph (a)(1)(i) of this section.

**§15.247(b)(4):** The conducted output power limit specified in paragraph (b) of this section is based on the use of antennas with directional gains that do not exceed 6 dBi. Except as shown in paragraph (c) of this section, if transmitting antennas of directional gain greater than 6 dBi are used, the conducted output power from the intentional radiator shall be reduced below the stated values in paragraphs (b)(1), (b)(2), and (b)(3) of this section, as appropriate, by the amount in dB that the directional gain of the antenna exceeds 6 dBi.

**5.4.2. Method of Measurements**

ANSI C63.10-2013, section 7.8.5

**5.4.3. Test Arrangement**

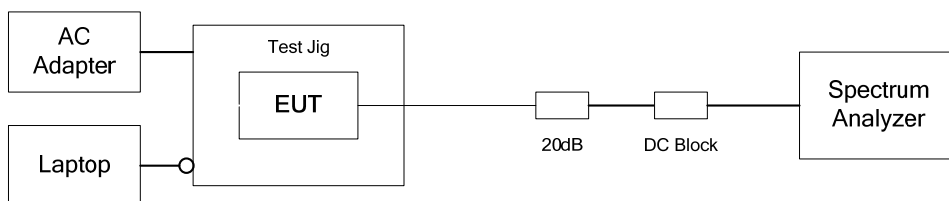

**5.4.4. Test Data**

Power Setting 1: High Power Setting for 3 dBi Rubber Duck Antenna with 3 dBi Antenna Assembly Gain								
Raw Power Setting (0 – 13)	Data Rate	Frequency (MHz)	Peak Output Power at Antenna Terminal		Antenna Assembly Gain (dBi)	EIRP (dBm)	Peak Conducted Output Power Limit (dBm)	EIRP Limit (dBm)
			(dBm)	(W)				
10	Low	902.40	29.96	0.9908	3	32.96	30	36
10	Low	915.00	29.99	0.9977	3	32.99	30	36
10	Low	927.60	29.94	0.9863	3	32.94	30	36
10	Middle	902.40	29.98	0.9954	3	32.98	30	36
10	Middle	914.90	29.95	0.9886	3	32.95	30	36
10	Middle	927.65	29.85	0.9661	3	32.85	30	36
10	High	903.00	29.99	0.9977	3	32.99	30	36
10	High	915.00	29.96	0.9908	3	32.96	30	36
10	High	927.50	29.97	0.9931	3	32.97	30	36



Power Setting 2: High Power Setting for 13.15 dBi Yagi Antenna with 12.67 dBi Antenna Assembly Gain								
Raw Power Setting (0 – 13)	Data Rate	Frequency (MHz)	Peak Output Power at Antenna Terminal		Antenna Assembly Gain (dBi)	EIRP (dBm)	Peak Conducted Output Power Limit (dBm)	EIRP Limit (dBm)
			(dBm)	(W)				
3	Low	902.40	23.32	0.2148	12.67	35.99	30	36
3	Low	915.00	23.30	0.2138	12.67	35.97	30	36
3	Low	927.60	21.81	0.1517	12.67	34.48	30	36
3	Middle	902.40	23.32	0.2148	12.67	35.99	30	36
3	Middle	914.90	23.30	0.2138	12.67	35.97	30	36
3	Middle	927.65	21.92	0.1556	12.67	34.59	30	36
3	High	903.00	23.31	0.2143	12.67	35.98	30	36
3	High	915.00	23.31	0.2143	12.67	35.98	30	36
3	High	927.50	21.75	0.1496	12.67	34.42	30	36

Power Setting 3: High Power Setting for 8 dBi Patch Antenna with 8 dBi Antenna Assembly Gain								
Raw Power Setting (0 – 13)	Data Rate	Frequency (MHz)	Peak Output Power at Antenna Terminal		Antenna Assembly Gain (dBi)	EIRP (dBm)	Peak Conducted Output Power Limit (dBm)	EIRP Limit (dBm)
			(dBm)	(W)				
4	Low	902.40	25.12	0.3251	8	33.12	30	36
4	Low	915.00	25.17	0.3289	8	33.17	30	36
4	Low	927.60	23.85	0.2427	8	31.85	30	36
4	Middle	902.40	25.21	0.3319	8	33.21	30	36
4	Middle	914.90	25.18	0.3296	8	33.18	30	36
4	Middle	927.65	23.73	0.2360	8	31.73	30	36
4	High	903.00	25.46	0.3516	8	33.46	30	36
4	High	915.00	25.24	0.3342	8	33.24	30	36
4	High	927.50	23.78	0.2388	8	31.78	30	36

Power Setting 4: High Power Setting for 8.15 dBi Omni Directional Antenna with 7.67 dBi Antenna Assembly Gain								
Raw Power Setting (0 – 13)	Data Rate	Frequency (MHz)	Peak Output Power at Antenna Terminal		Antenna Assembly Gain (dBi)	EIRP (dBm)	Peak Conducted Output Power Limit (dBm)	EIRP Limit (dBm)
			(dBm)	(W)				
7	Low	902.40	27.99	0.6295	7.67	35.66	30	36
7	Low	915.00	27.99	0.6295	7.67	35.66	30	36
7	Low	927.60	27.29	0.5358	7.67	34.96	30	36
7	Middle	902.40	27.92	0.6194	7.67	35.59	30	36
7	Middle	914.90	27.98	0.6281	7.67	35.65	30	36
7	Middle	927.65	27.34	0.5420	7.67	35.01	30	36
7	High	903.00	27.99	0.6295	7.67	35.66	30	36
7	High	915.00	27.96	0.6252	7.67	35.63	30	36
7	High	927.50	27.30	0.5370	7.67	34.97	30	36

Power Setting 5: High Power Setting for 4 dBi Puck Antenna with 4 dBi Antenna Assembly Gain								
Raw Power Setting (0 – 13)	Data Rate	Frequency (MHz)	Peak Output Power at Antenna Terminal		Antenna Assembly Gain (dBi)	EIRP (dBm)	Peak Conducted Output Power Limit (dBm)	EIRP Limit (dBm)
			(dBm)	(W)				
10	Low	902.40	29.96	0.9908	4	33.96	30	36
10	Low	915.00	29.99	0.9977	4	33.99	30	36
10	Low	927.60	29.94	0.9863	4	33.94	30	36
10	Middle	902.40	29.98	0.9954	4	33.98	30	36
10	Middle	914.90	29.95	0.9886	4	33.95	30	36
10	Middle	927.65	29.85	0.9661	4	33.85	30	36
10	High	903.00	29.99	0.9977	4	33.99	30	36
10	High	915.00	29.96	0.9908	4	33.96	30	36
10	High	927.50	29.97	0.9931	4	33.97	30	36

Power Setting 6: Low Power Setting for All Antenna Types				
Raw Power Setting (0 – 13)	Data Rate	Frequency (MHz)	Peak Output Power at Antenna Terminal	
			(dBm)	(W)
0	Low	902.40	21.30	0.1349
0	Low	915.00	21.19	0.1315
0	Low	927.60	18.90	0.0776
0	Middle	902.40	21.78	0.1507
0	Middle	914.90	21.30	0.1349
0	Middle	927.65	19.57	0.0906
0	High	903.00	21.77	0.1503
0	High	915.00	21.46	0.1400
0	High	927.50	19.50	0.0891

**5.5. TRANSMITTER SPURIOUS RADIATED EMISSIONS AT 3 METERS [§§ 15.247(d), 15.209 & 15.205]**

**5.5.1. Limit**

§ 15.247 (d): In any 100 kHz bandwidth outside the frequency band in which the spread spectrum or digitally modulated intentional radiator is operating, the radio frequency power that is produced by the intentional radiator shall be at least 20 dB below that in the 100 kHz bandwidth within the band that contains the highest level of the desired power, based on either an RF conducted or a radiated measurement, provided the transmitter demonstrates compliance with the peak conducted power limits. If the transmitter complies with the conducted power limits based on the use of RMS averaging over a time interval, as permitted under paragraph (b)(3) of this section, the attenuation required under this paragraph shall be 30 dB instead of 20 dB. Attenuation below the general limits specified in §15.209(a) is not required. In addition, radiated emissions which fall in the restricted bands, as defined in §15.205(a), must also comply with the radiated emission limits specified in §15.209(a) (see §15.205(c)).

**Section 15.205(a) - Restricted Bands of Operation**

MHz	MHz	MHz	GHz
0.090–0.110 .....	16.42–16.423	399.9–410	4.5–5.15
<sup>1</sup> 0.495–0.505 .....	16.69475–16.69525	608–614	5.35–5.46
2.1735–2.1905 .....	16.80425–16.80475	960–1240	7.25–7.75
4.125–4.128 .....	25.5–25.67	1300–1427	8.025–8.5
4.17725–4.17775 .....	37.5–38.25	1435–1626.5	9.0–9.2
4.20725–4.20775 .....	73–74.6	1645.5–1646.5	9.3–9.5
6.215–6.218 .....	74.8–75.2	1660–1710	10.6–12.7
6.26775–6.26825 .....	108–121.94	1718.8–1722.2	13.25–13.4
6.31175–6.31225 .....	123–138	2200–2300	14.47–14.5
8.291–8.294 .....	149.9–150.05	2310–2390	15.35–16.2
8.362–8.366 .....	156.52475–156.52525	2483.5–2500	17.7–21.4
8.37625–8.38675 .....	156.7–156.9	2655–2900	22.01–23.12
8.41425–8.41475 .....	162.0125–167.17	3260–3267	23.6–24.0
12.29–12.293 .....	167.72–173.2	3332–3339	31.2–31.8
12.51975–12.52025 .....	240–285	3345.8–3358	36.43–36.5
12.57675–12.57725 .....	322–335.4	3600–4400	( <sup>2</sup> )
13.36–13.41.			

<sup>1</sup> Until February 1, 1999, this restricted band shall be 0.490–0.510 MHz.

<sup>2</sup> Above 38.6

**Section 15.209(a) - Field Strength Limits within Restricted Frequency Bands**

Frequency (MHz)	Field Strength (microvolts/meter)	Measurement Distance (meters)
0.009 - 0.490	2,400 / F (kHz)	300
0.490 - 1.705	24,000 / F (kHz)	30
1.705 - 30.0	30	30
30 - 88	100	3
88 - 216	150	3
216 - 960	200	3
Above 960	500	3

5.5.2. Method of Measurements

ANSI C63.10 and ANSI 63.4 procedures.

5.5.3. Test Arrangement

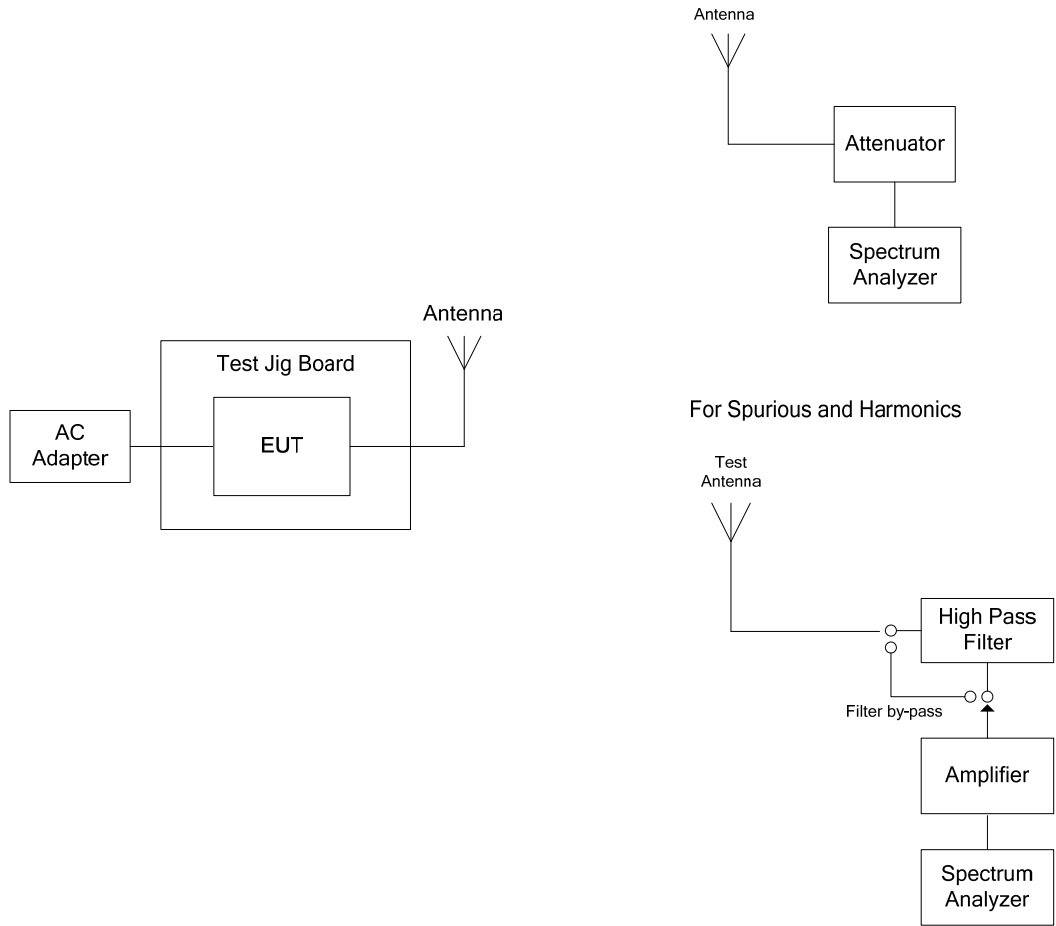

**5.5.4. Test Data**

**Remark(s):**

- All spurious emissions that are in excess of 20 dB below the specified limit shall be recorded.
- EUT shall be tested in three orthogonal positions.
- The following test data represent the worst-case derived from exploratory tests.

**5.5.4.1. EUT with 3 dBi Rubber Duck Antenna, 3 dBi Antenna Assembly Gain, Low Data Rate**

**5.5.4.1.1. Spurious Radiated Emission**

Fundamental Frequency:		902.4 MHz					
Raw Power Setting:		10					
Measured Conducted Power:		29.96 dBm					
Frequency Test Range:		30 MHz – 10 GHz					
Frequency (MHz)	RF Peak Level (dBµV/m)	RF Avg Level (dBµV/m)	Antenna Plane (H/V)	Limit 15.209 (dBµV/m)	Limit 15.247 (dBµV/m)	Margin (dB)	Pass/Fail
902.4	130.90	--	V	--	--	--	--
902.4	128.13	--	H	--	--	--	--
2707.2	50.79	46.51	V	54.0	110.9	-7.5	Pass*
2707.2	49.45	43.92	H	54.0	110.9	-10.1	Pass*
3609.6	47.15	36.15	V	54.0	110.9	-17.9	Pass*
3609.6	48.93	40.63	H	54.0	110.9	-13.4	Pass*
4512.0	48.63	34.69	V	54.0	110.9	-19.3	Pass*
4512.0	49.96	35.43	H	54.0	110.9	-18.6	Pass*
8121.6	55.34	42.03	V	54.0	110.9	-12.0	Pass*
8121.6	54.69	43.51	H	54.0	110.9	-10.5	Pass*
9024.0	56.23	43.73	V	54.0	110.9	-10.3	Pass*
9024.0	57.07	46.78	H	54.0	110.9	-7.2	Pass*
All other spurious emissions and harmonics are more than 20 dB below the applicable limit.							

\*Field strength of emissions appearing within restricted frequency bands shall not exceed the limits in § 15.209.

Fundamental Frequency:		915.0 MHz					
Raw Power Setting:		10					
Measured Conducted Power:		29.99 dBm					
Frequency Test Range:		30 MHz – 10 GHz					
Frequency (MHz)	RF Peak Level (dBµV/m)	RF Avg Level (dBµV/m)	Antenna Plane (H/V)	Limit 15.209 (dBµV/m)	Limit 15.247 (dBµV/m)	Margin (dB)	Pass/Fail
915.0	129.55	--	V	--	--	--	--
915.0	129.47	--	H	--	--	--	--
2745.0	52.60	49.41	V	54.0	109.6	-4.6	Pass*
2745.0	48.80	42.41	H	54.0	109.6	-11.6	Pass*
3660.0	47.63	36.07	V	54.0	109.6	-17.9	Pass*
3660.0	49.39	41.62	H	54.0	109.6	-12.4	Pass*
4575.0	49.46	38.18	V	54.0	109.6	-15.8	Pass*
4575.0	49.52	37.49	H	54.0	109.6	-16.5	Pass*
7320.0	54.06	41.90	V	54.0	109.6	-12.1	Pass*
7320.0	54.74	43.60	H	54.0	109.6	-10.4	Pass*
8235.0	54.22	42.60	V	54.0	109.6	-11.4	Pass*
8235.0	56.58	47.68	H	54.0	109.6	-6.3	Pass*
9150.0	56.14	43.11	V	54.0	109.6	-10.9	Pass*
9150.0	56.86	43.25	H	54.0	109.6	-10.8	Pass*
All other spurious emissions and harmonics are more than 20 dB below the applicable limit.							

\*Field strength of emissions appearing within restricted frequency bands shall not exceed the limits in § 15.209.

Fundamental Frequency:		927.6 MHz					
Raw Power Setting:		10					
Measured Conducted Power:		29.94 dBm					
Frequency Test Range:		30 MHz – 10 GHz					
Frequency (MHz)	RF Peak Level (dB $\mu$ V/m)	RF Avg Level (dB $\mu$ V/m)	Antenna Plane (H/V)	Limit 15.209 (dB $\mu$ V/m)	Limit 15.247 (dB $\mu$ V/m)	Margin (dB)	Pass/Fail
927.6	128.28	--	V	--	--	--	--
927.6	130.09	--	H	--	--	--	--
2782.8	51.43	46.90	V	54.0	110.1	-7.1	Pass*
2782.8	48.89	43.39	H	54.0	110.1	-10.6	Pass*
3710.4	46.80	34.71	V	54.0	110.1	-19.3	Pass*
3710.4	47.29	36.71	H	54.0	110.1	-17.3	Pass*
4638.0	48.55	35.06	V	54.0	110.1	-18.9	Pass*
4638.0	48.88	35.58	H	54.0	110.1	-18.4	Pass*
7420.8	53.51	42.53	V	54.0	110.1	-11.5	Pass*
7420.8	54.01	42.89	H	54.0	110.1	-11.1	Pass*
8348.4	55.16	41.04	V	54.0	110.1	-13.0	Pass*
8348.4	54.80	41.94	H	54.0	110.1	-12.1	Pass*
All other spurious emissions and harmonics are more than 20 dB below the applicable limit.							

\*Field strength of emissions appearing within restricted frequency bands shall not exceed the limits in § 15.209.



5.5.4.1.2. Band –Edge RF Radiated Emissions

Plot 5.5.4.1.2.1. Band-Edge RF Radiated Emissions at 3 m, Horizontal Polarization  
Single Frequency Mode, Low End of Frequency Band

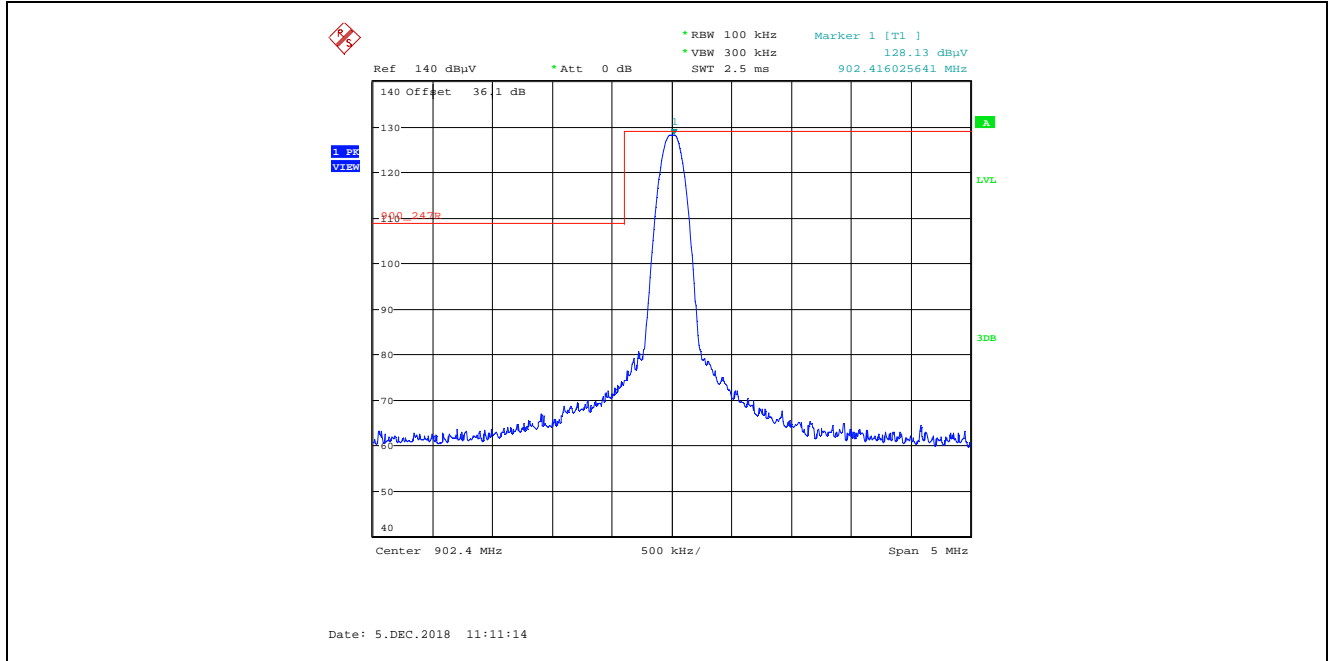

Plot 5.5.4.1.2.2. Band-Edge RF Radiated Emissions at 3 m, Horizontal Polarization  
Pseudorandom Channel Hopping Mode, Low End of Frequency Band

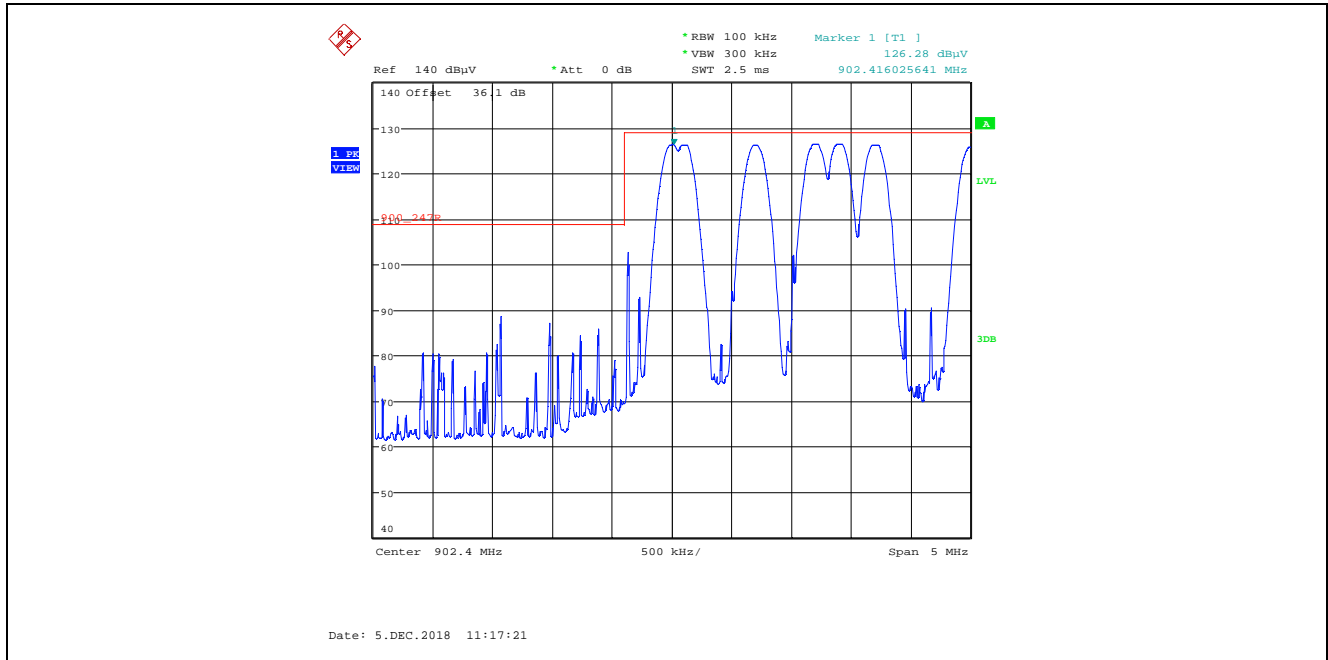

**Plot 5.5.4.1.2.3.** Band-Edge RF Radiated Emissions at 3 m, Vertical Polarization  
 Single Frequency Mode, Low End of Frequency Band

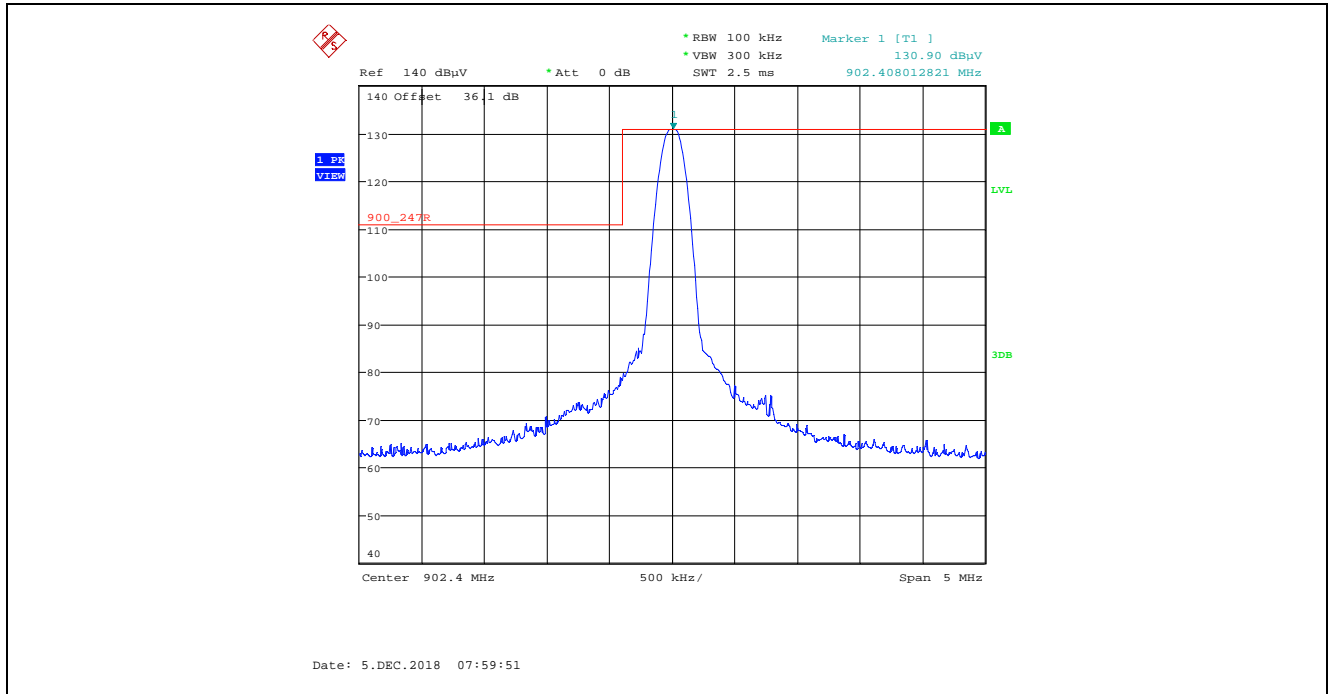

**Plot 5.5.4.1.2.4.** Band-Edge RF Radiated Emissions at 3 m, Vertical Polarization  
 Pseudorandom Channel Hopping Mode, Low End of Frequency Band

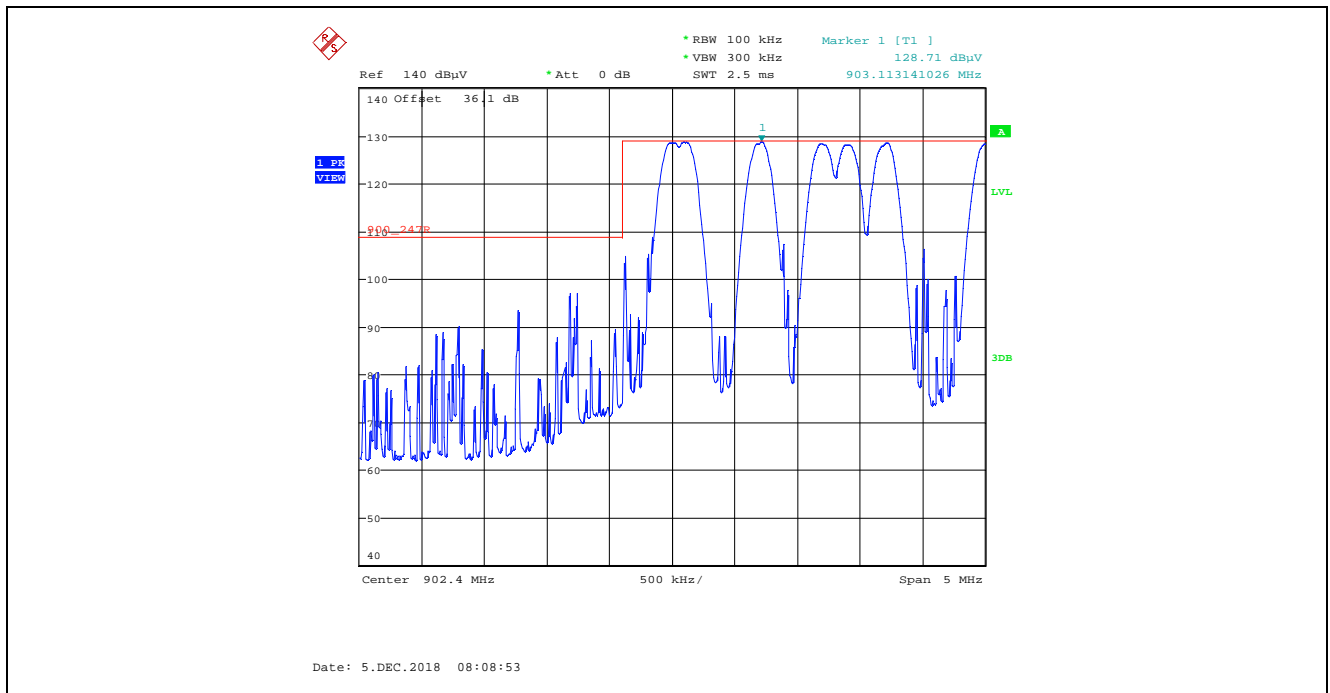

Plot 5.5.4.1.2.5. Band-Edge RF Radiated Emissions at 3 m, Horizontal Polarization  
Single Frequency Mode, High End of Frequency Band

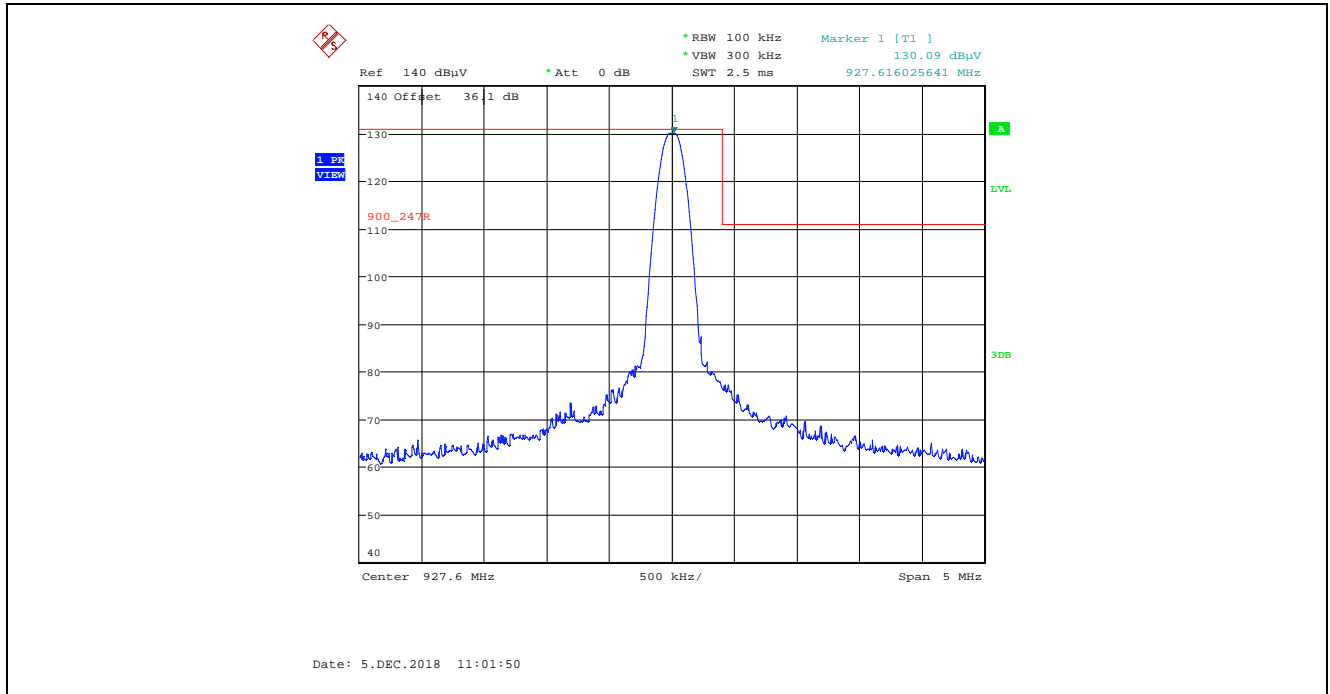

Plot 5.5.4.1.2.6. Band-Edge RF Radiated Emissions at 3 m, Horizontal Polarization  
Pseudorandom Channel Hopping Mode, High End of Frequency Band

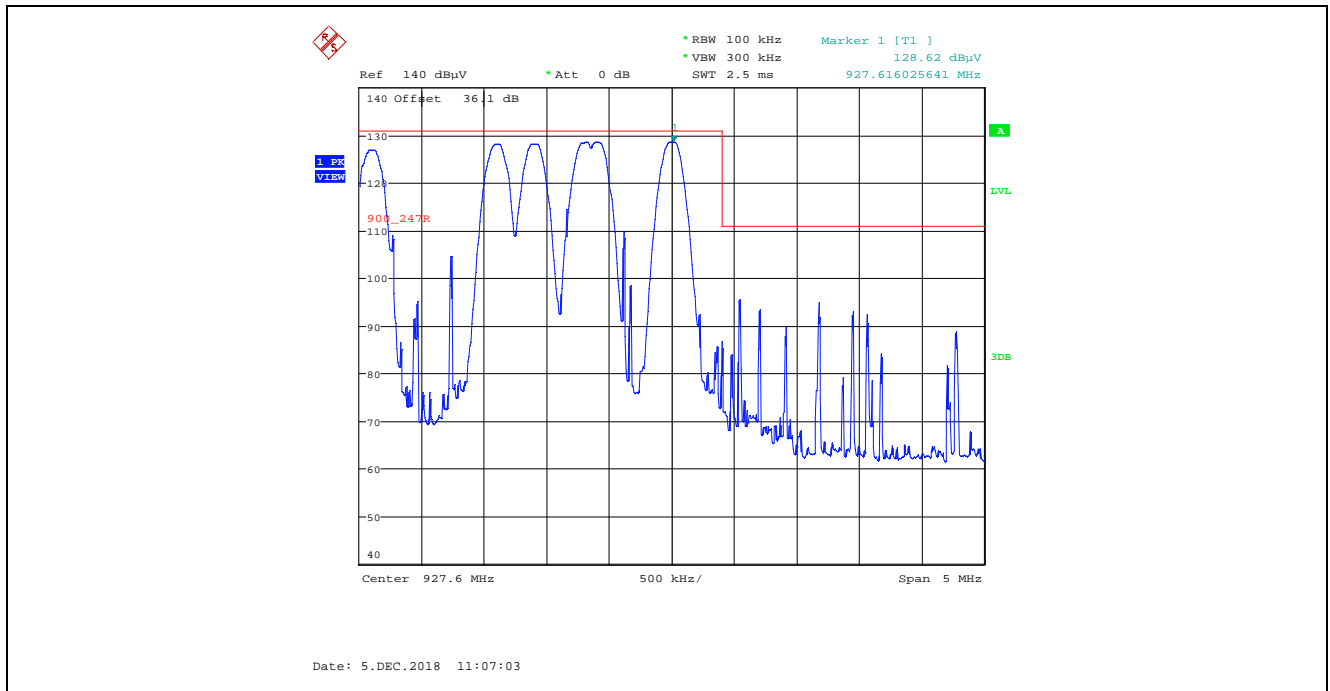

Plot 5.5.4.1.2.7. Band-Edge RF Radiated Emissions at 3 m, Vertical Polarization  
Single Frequency Mode, High of Frequency Band

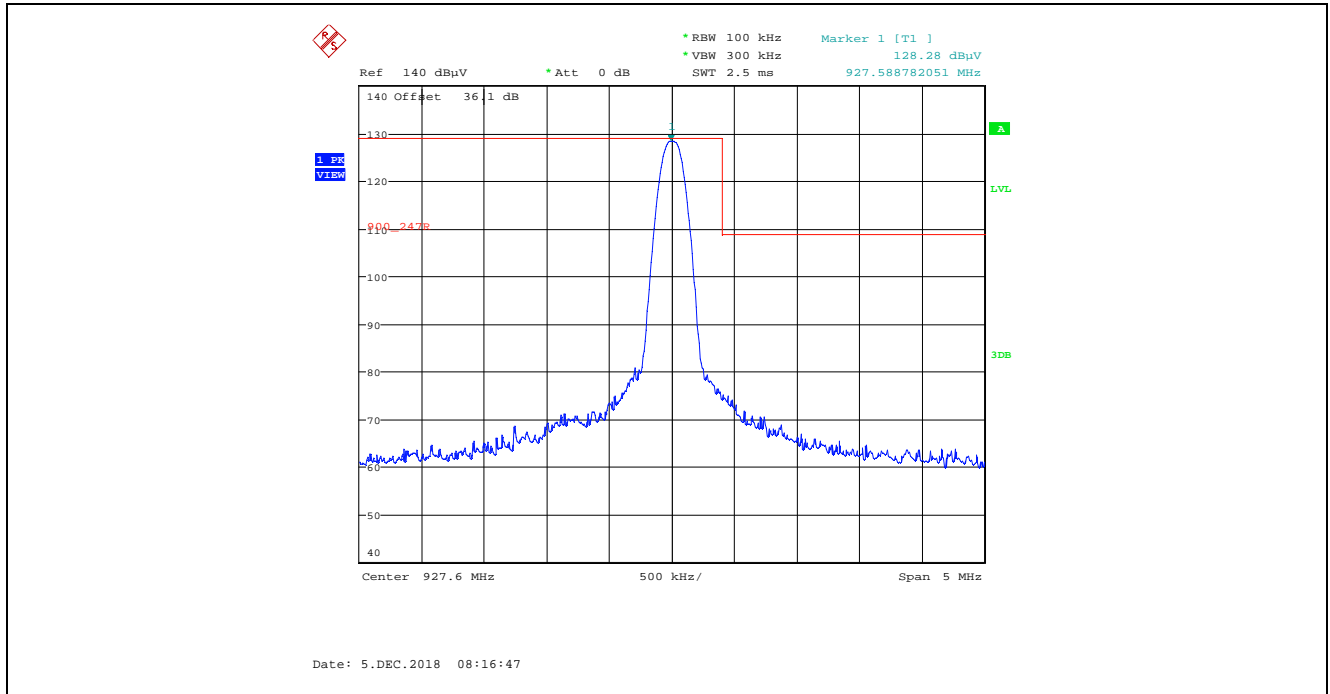

Plot 5.5.4.1.2.8. Band-Edge RF Radiated Emissions at 3 m, Vertical Polarization  
Pseudorandom Channel Hopping Mode, High End of Frequency Band

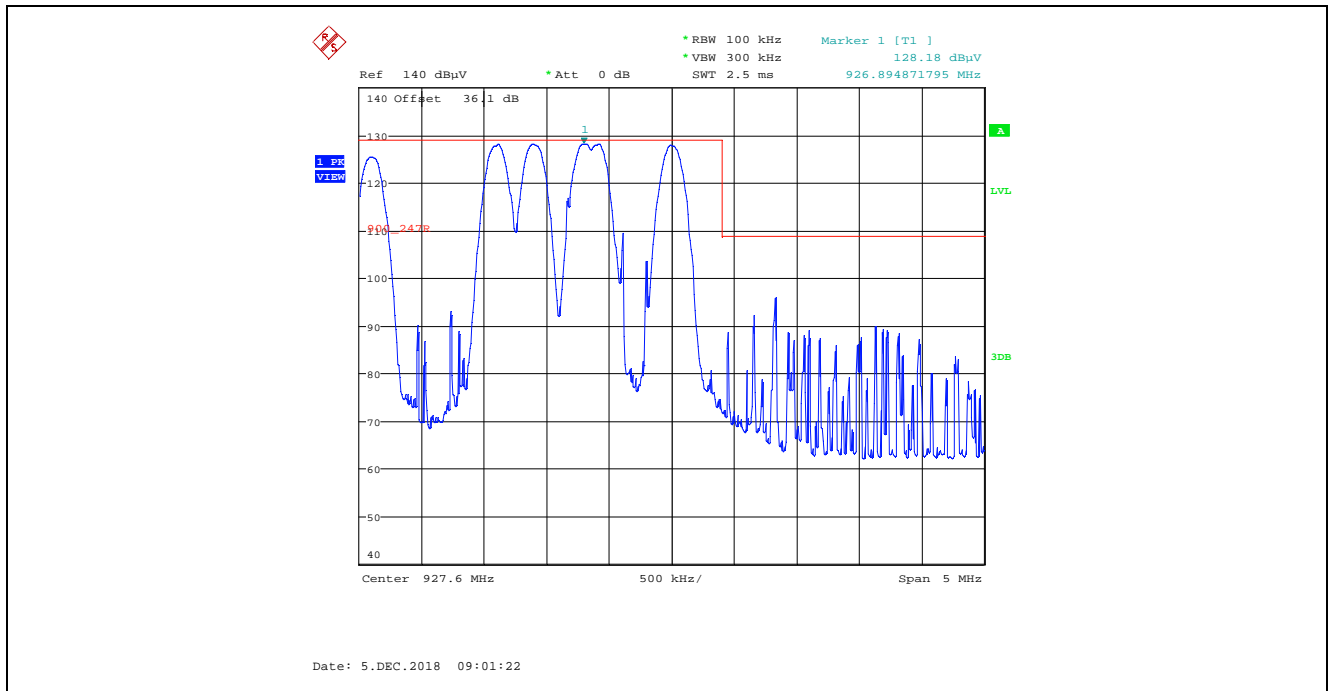

**5.5.4.2. EUT with 13.15 dBi Yagi Antenna, 12.67 dBi Antenna Assembly Gain, Low Data Rate**

**5.5.4.2.1. Spurious Radiated Emissions**

Fundamental Frequency:		902.4 MHz					
Raw Power Setting:		3					
Measured Conducted Power:		23.32 dBm					
Frequency Test Range:		30 MHz – 10 GHz					
Frequency (MHz)	RF Peak Level (dBµV/m)	RF Avg Level (dBµV/m)	Antenna Plane (H/V)	Limit 15.209 (dBµV/m)	Limit 15.247 (dBµV/m)	Margin (dB)	Pass/Fail
902.4	124.09	--	V	--	--	--	--
902.4	123.28	--	H	--	--	--	--
2707.2	45.37	38.96	H	54.0	104.1	-15.0	Pass*
3609.6	46.08	38.41	H	54.0	104.1	-15.6	Pass*
All other spurious emissions and harmonics are more than 20 dB below the applicable limit.							

\*Field strength of emissions appearing within restricted frequency bands shall not exceed the limits in § 15.209.

Fundamental Frequency:		915 MHz					
Raw Power Setting:		3					
Measured Conducted Power:		23.30 dBm					
Frequency Test Range:		30 MHz – 10 GHz					
Frequency (MHz)	RF Peak Level (dBµV/m)	RF Avg Level (dBµV/m)	Antenna Plane (H/V)	Limit 15.209 (dBµV/m)	Limit 15.247 (dBµV/m)	Margin (dB)	Pass/Fail
915.0	124.33	--	V	--	--	--	--
915.0	124.55	--	H	--	--	--	--
2745.0	45.28	35.17	V	54.0	104.6	-18.8	Pass*
2745.0	48.15	42.48	H	54.0	104.6	-11.5	Pass*
3660.0	47.81	36.66	H	54.0	104.6	-17.3	Pass*
All other spurious emissions and harmonics are more than 20 dB below the applicable limit.							

\*Field strength of emissions appearing within restricted frequency bands shall not exceed the limits in § 15.209.

Fundamental Frequency:		927.6 MHz					
Raw Power Setting:		3					
Measured Conducted Power:		21.81 dBm					
Frequency Test Range:		30 MHz – 10 GHz					
Frequency (MHz)	RF Peak Level (dB $\mu$ V/m)	RF Avg Level (dB $\mu$ V/m)	Antenna Plane (H/V)	Limit 15.209 (dB $\mu$ V/m)	Limit 15.247 (dB $\mu$ V/m)	Margin (dB)	Pass/Fail
927.6	124.98	--	V	--	--	--	--
927.6	126.60	--	H	--	--	--	--
2782.8	47.87	40.65	H	54.0	106.6	-13.4	Pass*
All other spurious emissions and harmonics are more than 20 dB below the applicable limit.							

\*Field strength of emissions appearing within restricted frequency bands shall not exceed the limits in § 15.209.

5.5.4.2.2. Band –Edge RF Radiated Emissions

Plot 5.5.4.2.2.1. Band-Edge RF Radiated Emissions at 3 m, Horizontal Polarization  
Single Frequency Mode, Low End of Frequency Band

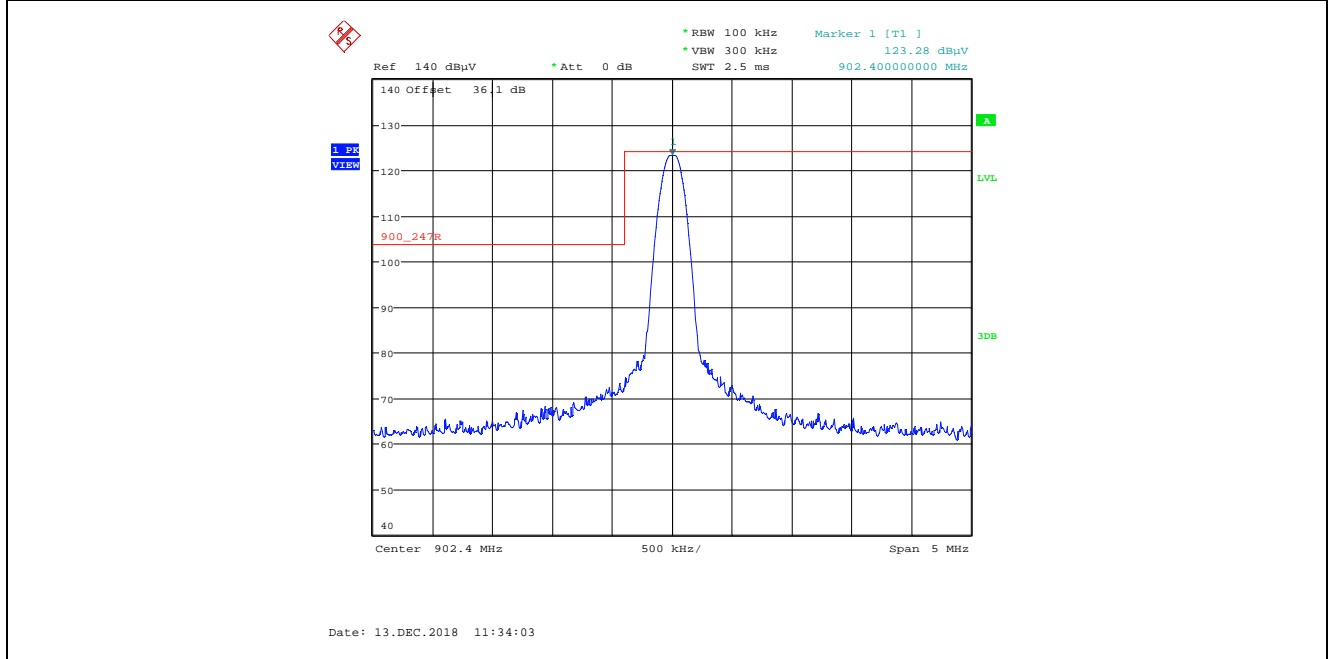

Plot 5.5.4.2.2.2. Band-Edge RF Radiated Emissions at 3 m, Horizontal Polarization  
Pseudorandom Channel Hopping Mode, Low End of Frequency Band

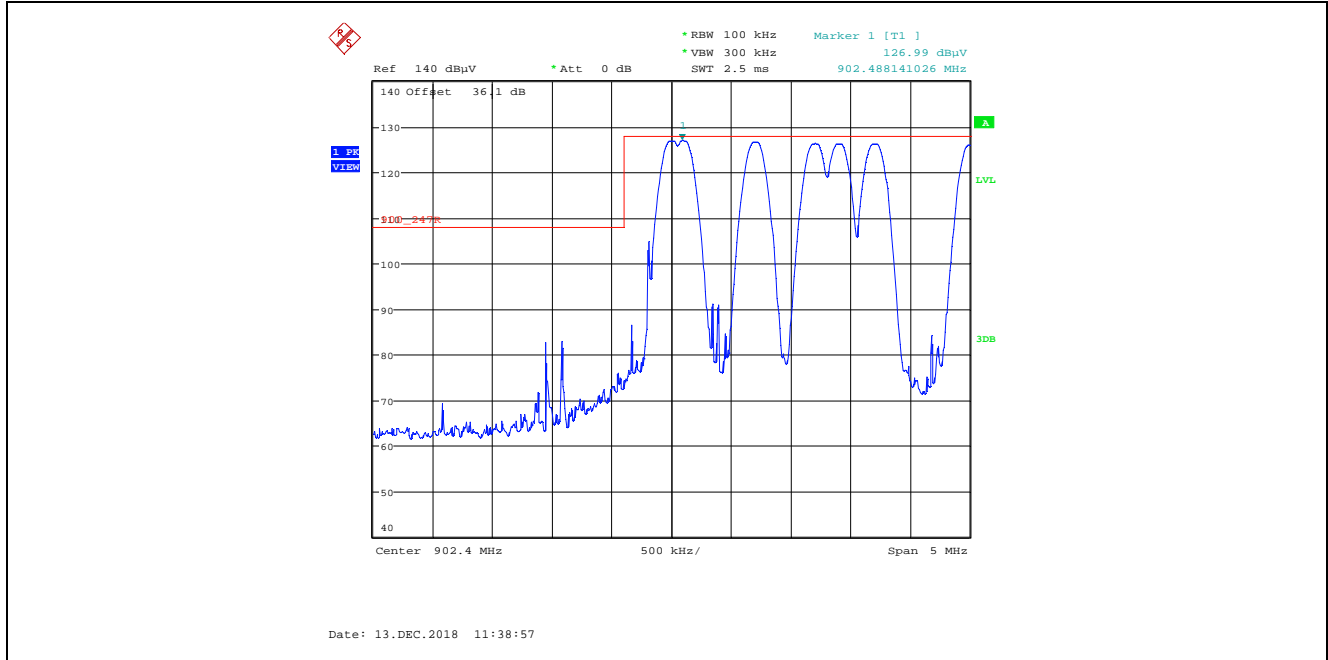

Plot 5.5.4.2.2.3. Band-Edge RF Radiated Emissions at 3 m, Vertical Polarization  
Single Frequency Mode, Low End of Frequency Band

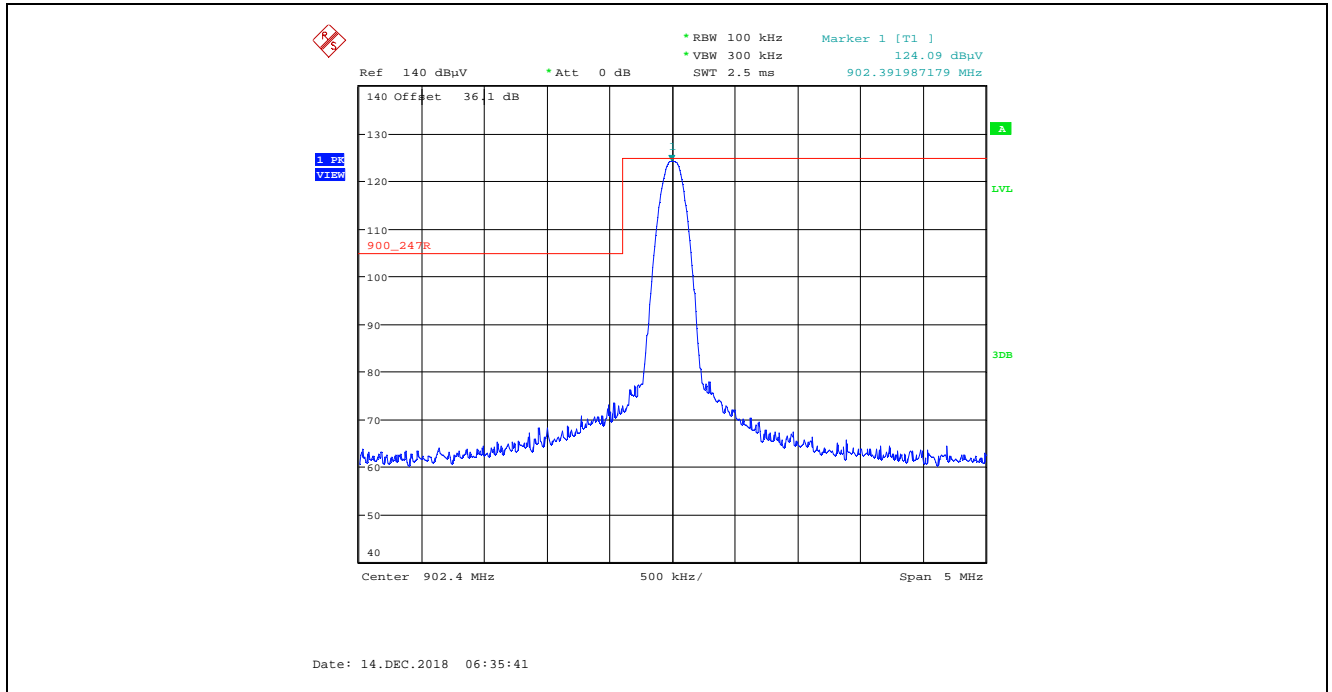

Plot 5.5.4.2.2.4. Band-Edge RF Radiated Emissions at 3 m, Vertical Polarization  
Pseudorandom Channel Hopping Mode, Low End of Frequency Band

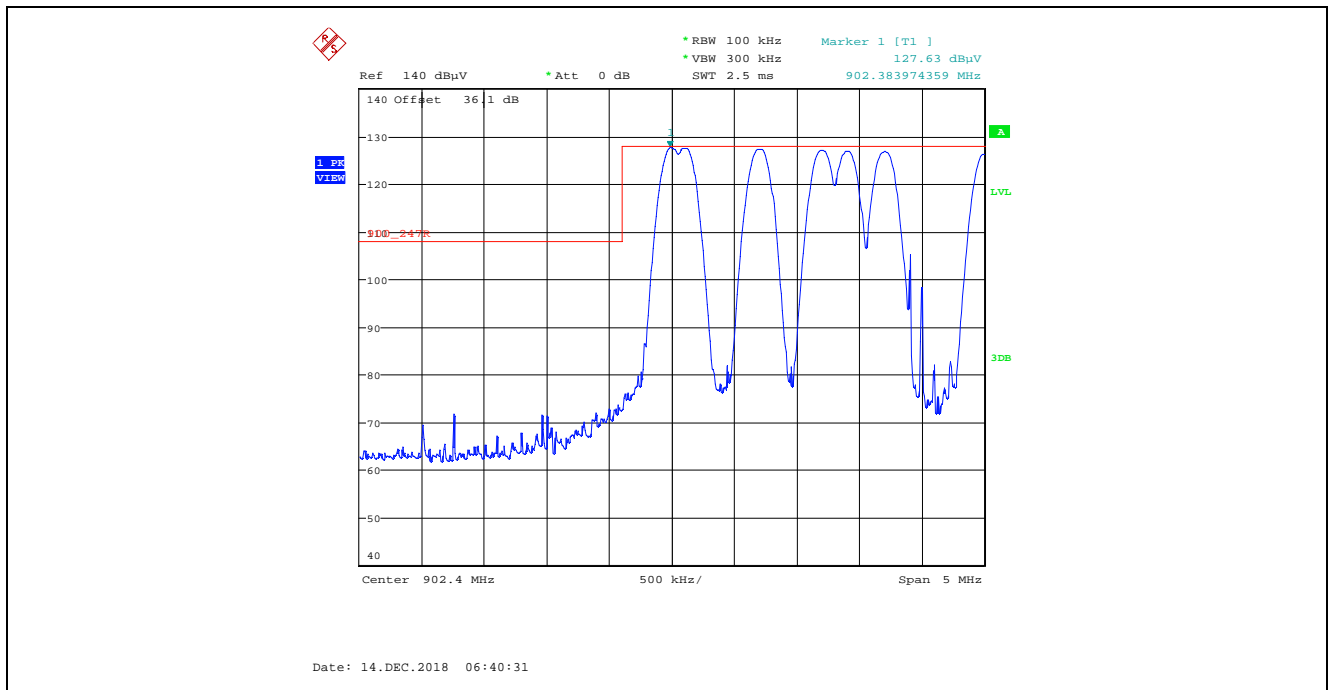



**Plot 5.5.4.2.2.5. Band-Edge RF Radiated Emissions at 3 m, Horizontal Polarization  
 Single Frequency Mode, High End of Frequency Band**

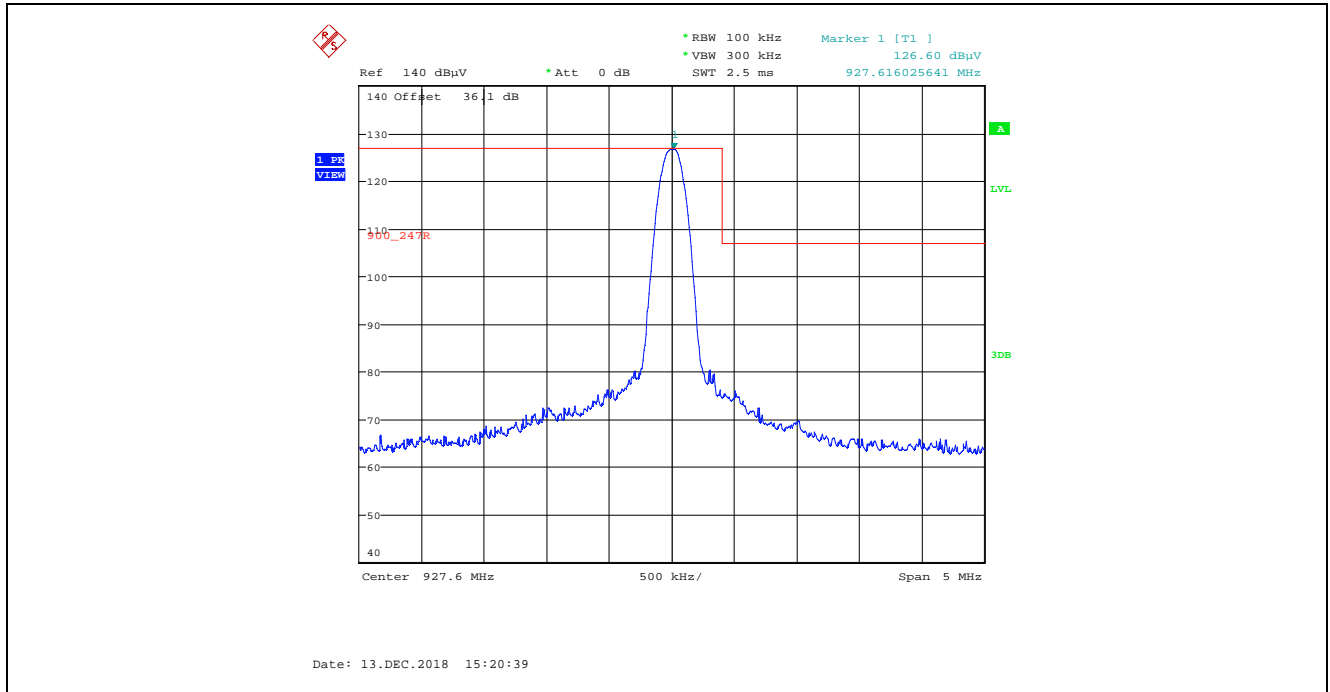

**Plot 5.5.4.2.2.6. Band-Edge RF Radiated Emissions at 3 m, Horizontal Polarization  
 Pseudorandom Channel Hopping Mode, High End of Frequency Band**

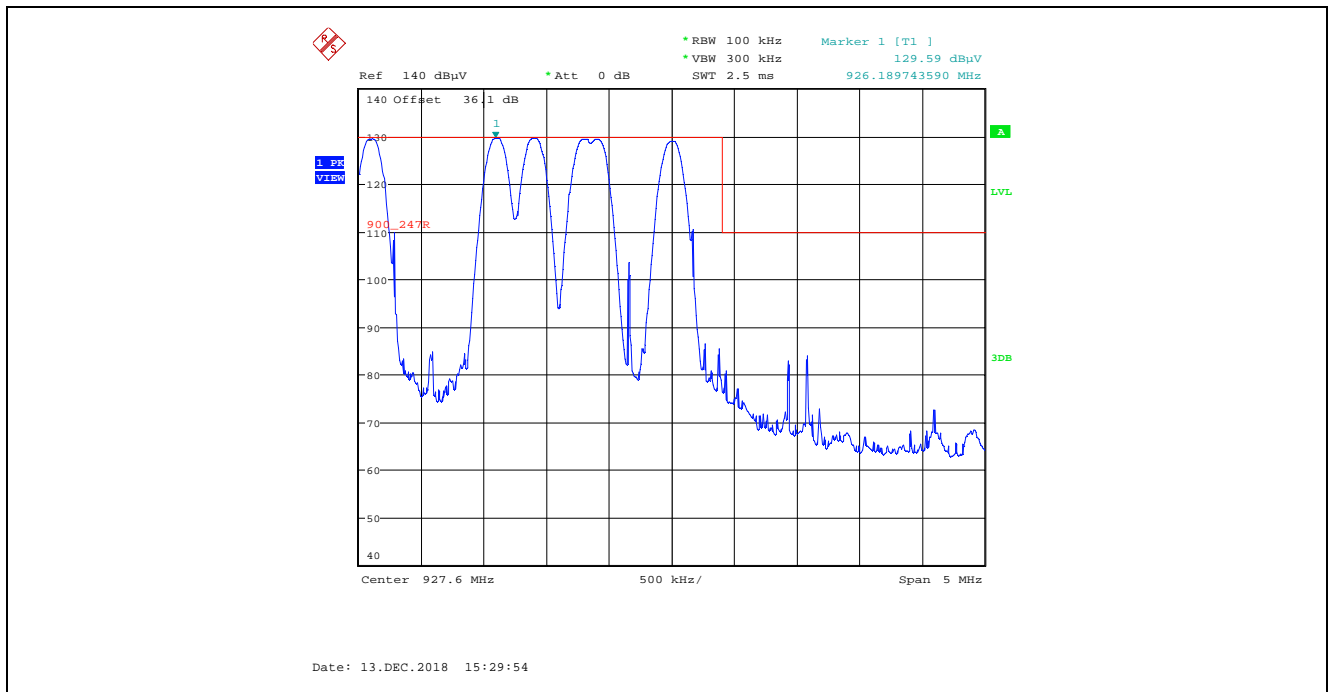

Plot 5.5.4.2.2.7. Band-Edge RF Radiated Emissions at 3 m, Vertical Polarization  
Single Frequency Mode, High of Frequency Band

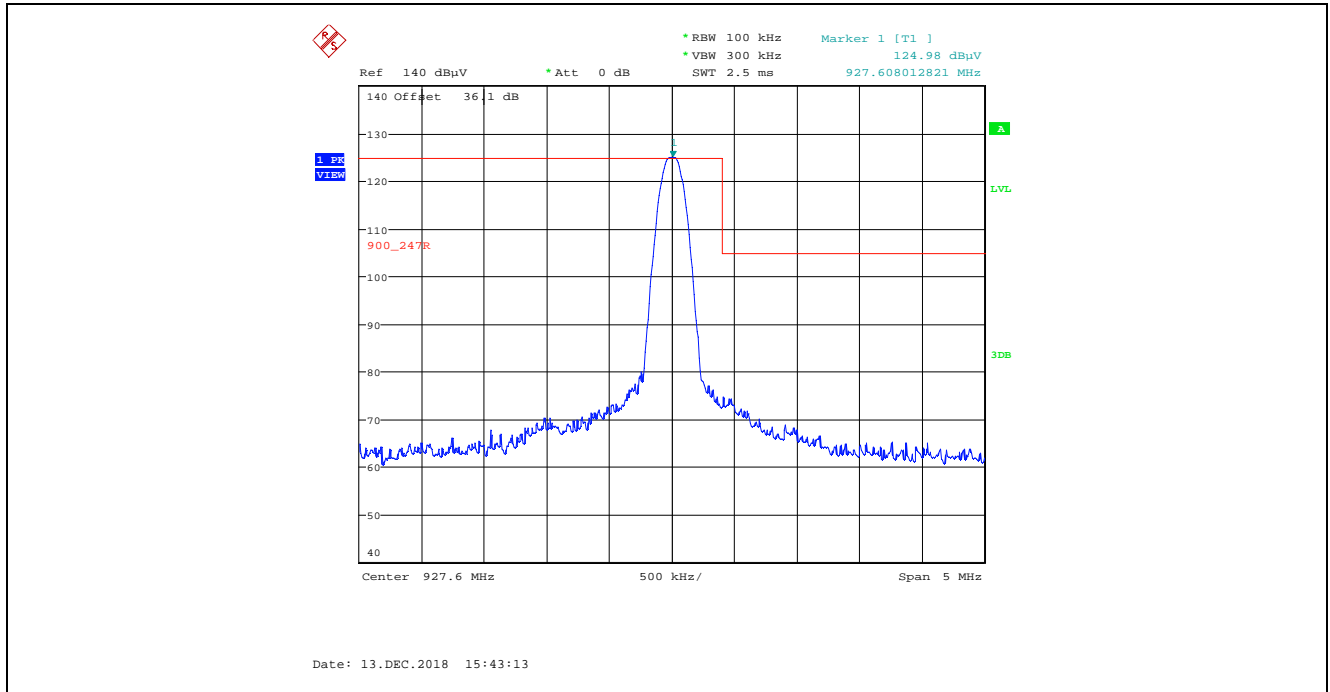

Plot 5.5.4.2.2.8. Band-Edge RF Radiated Emissions at 3 m, Vertical Polarization  
Pseudorandom Channel Hopping Mode, High End of Frequency Band

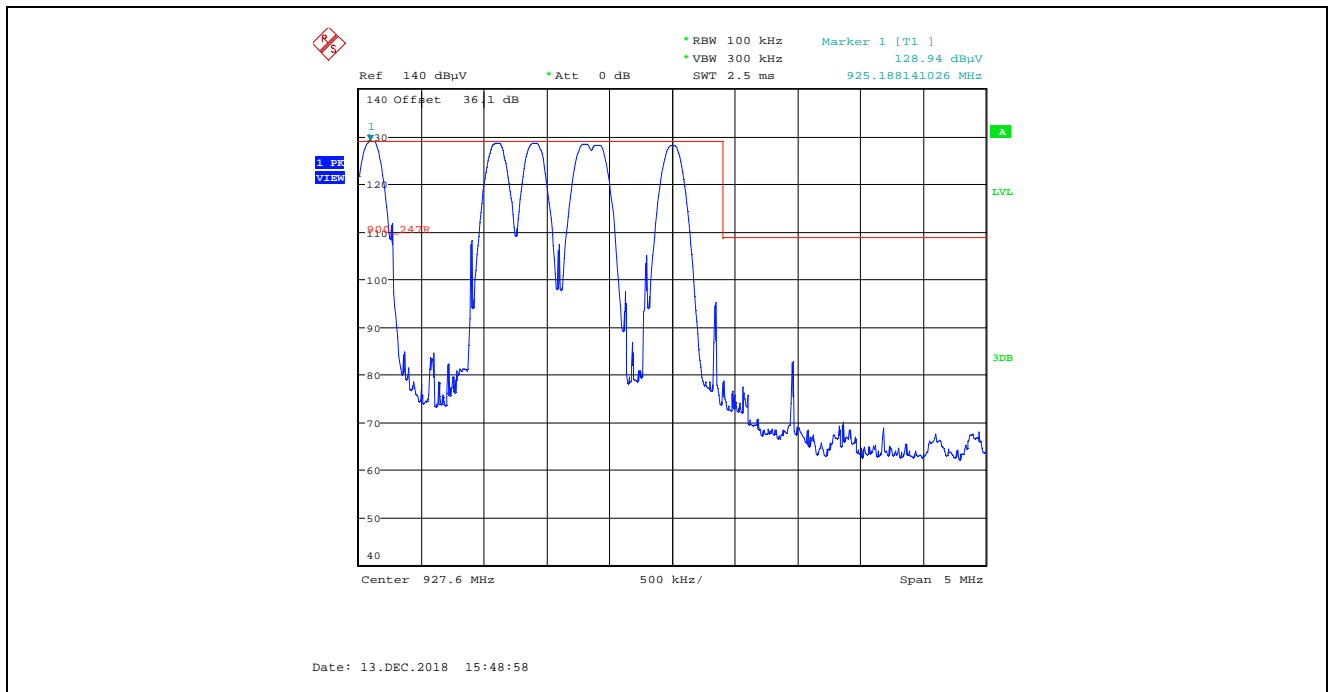

**5.5.4.3. EUT with 8 dBi Patch Antenna, 8 dBi Antenna Assembly Gain, Low Data Rate**

**5.5.4.3.1. Spurious Radiated Emissions**

Fundamental Frequency:		902.4 MHz					
Raw Power Setting:		4					
Measured Conducted Power:		25.12 dBm					
Frequency Test Range:		30 MHz – 10 GHz					
Frequency (MHz)	RF Peak Level (dBµV/m)	RF Avg Level (dBµV/m)	Antenna Plane (H/V)	Limit 15.209 (dBµV/m)	Limit 15.247 (dBµV/m)	Margin (dB)	Pass/Fail
902.4	126.70	--	V	--	--	--	--
902.4	125.17	--	H	--	--	--	--
2707.2	46.45	34.26	V	54.0	106.7	-19.7	Pass*
2707.2	47.84	40.55	H	54.0	106.7	-13.5	Pass*
3609.6	47.36	37.63	V	54.0	106.7	-16.4	Pass*
3609.6	49.04	41.54	H	54.0	106.7	-12.5	Pass*
8121.6	53.64	40.65	V	54.0	106.7	-13.4	Pass*
8121.6	54.42	41.92	H	54.0	106.7	-12.1	Pass*
9024.0	56.02	41.12	V	54.0	106.7	-12.9	Pass*
9024.0	57.06	46.12	H	54.0	106.7	-7.9	Pass*
All other spurious emissions and harmonics are more than 20 dB below the applicable limit.							

\*Field strength of emissions appearing within restricted frequency bands shall not exceed the limits in § 15.209.

Fundamental Frequency:		915.0 MHz					
Raw Power Setting:		4					
Measured Conducted Power:		25.17 dBm					
Frequency Test Range:		30 MHz – 10 GHz					
Frequency (MHz)	RF Peak Level (dBµV/m)	RF Avg Level (dBµV/m)	Antenna Plane (H/V)	Limit 15.209 (dBµV/m)	Limit 15.247 (dBµV/m)	Margin (dB)	Pass/Fail
915.0	127.71	--	V	--	--	--	--
915.0	127.11	--	H	--	--	--	--
2745.0	46.51	36.39	V	54.0	107.7	-17.6	Pass*
2745.0	47.25	41.38	H	54.0	107.7	-12.6	Pass*
3660.0	49.44	39.35	V	54.0	107.7	-14.7	Pass*
3660.0	48.76	41.17	H	54.0	107.7	-12.8	Pass*
4575.0	48.74	35.91	V	54.0	107.7	-18.1	Pass*
4575.0	49.37	38.35	H	54.0	107.7	-15.7	Pass*
7320.0	53.77	40.83	V	54.0	107.7	-13.2	Pass*
7320.0	52.99	40.1	H	54.0	107.7	-13.9	Pass*
8235.0	54.38	40.18	V	54.0	107.7	-13.8	Pass*
8235.0	55.23	44.69	H	54.0	107.7	-9.3	Pass*
9150.0	56.31	43.21	V	54.0	107.7	-10.8	Pass*
9150.0	58.57	48.43	H	54.0	107.7	-5.6	Pass*
All other spurious emissions and harmonics are more than 20 dB below the applicable limit.							

\*Field strength of emissions appearing within restricted frequency bands shall not exceed the limits in § 15.209.

Fundamental Frequency:		927.6 MHz					
Raw Power Setting:		4					
Measured Conducted Power:		23.85 dBm					
Frequency Test Range:		30 MHz – 10 GHz					
Frequency (MHz)	RF Peak Level (dBµV/m)	RF Avg Level (dBµV/m)	Antenna Plane (H/V)	Limit 15.209 (dBµV/m)	Limit 15.247 (dBµV/m)	Margin (dB)	Pass/Fail
927.6	128.68	--	V	--	--	--	--
927.6	129.86	--	H	--	--	--	--
2782.8	46.94	36.65	V	54.0	109.9	-17.4	Pass*
2782.8	50.31	45.66	H	54.0	109.9	-8.3	Pass*
3710.4	47.28	34.41	V	54.0	109.9	-19.6	Pass*
3710.4	47.69	39.42	H	54.0	109.9	-14.6	Pass*
4638.0	48.22	34.11	V	54.0	109.9	-19.9	Pass*
4638.0	48.51	36.26	H	54.0	109.9	-17.7	Pass*
7420.8	53.14	41.48	V	54.0	109.9	-12.5	Pass*
7420.8	53.26	40.90	H	54.0	109.9	-13.1	Pass*
8348.4	53.93	40.46	V	54.0	109.9	-13.5	Pass*
8348.4	54.73	44.00	H	54.0	109.9	-10.0	Pass*
All other spurious emissions and harmonics are more than 20 dB below the applicable limit.							

\*Field strength of emissions appearing within restricted frequency bands shall not exceed the limits in § 15.209.

5.5.4.3.2. Band –Edge RF Radiated Emissions

Plot 5.5.4.3.2.1. Band-Edge RF Radiated Emissions at 3 m, Horizontal Polarization  
Single Frequency Mode, Low End of Frequency Band

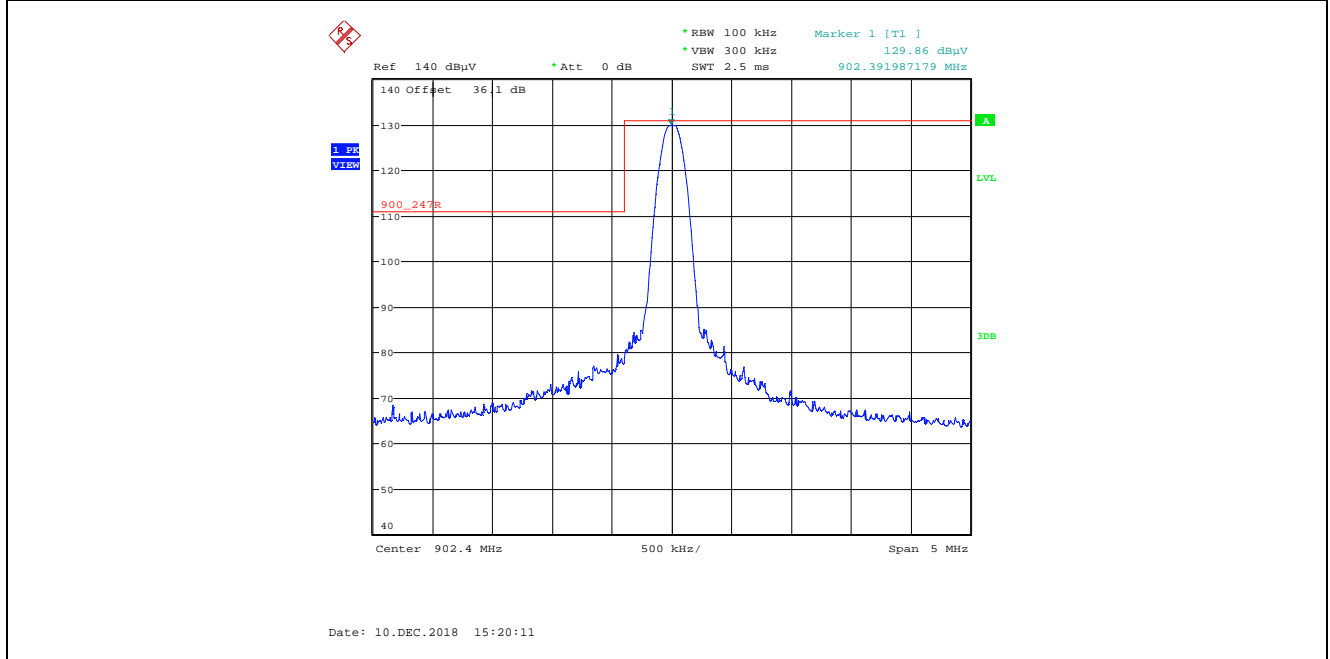

Plot 5.5.4.3.2.2. Band-Edge RF Radiated Emissions at 3 m, Horizontal Polarization  
Pseudorandom Channel Hopping Mode, Low End of Frequency Band

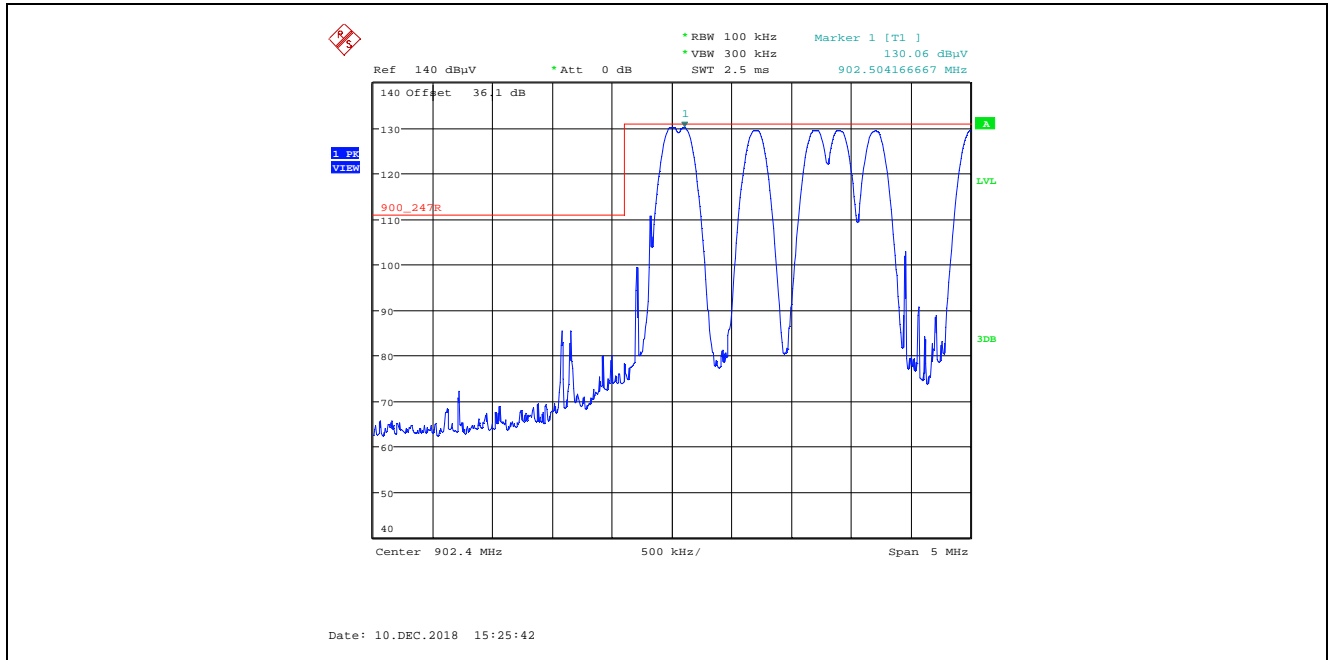

Plot 5.5.4.3.2.3. Band-Edge RF Radiated Emissions at 3 m, Vertical Polarization  
Single Frequency Mode, Low End of Frequency Band

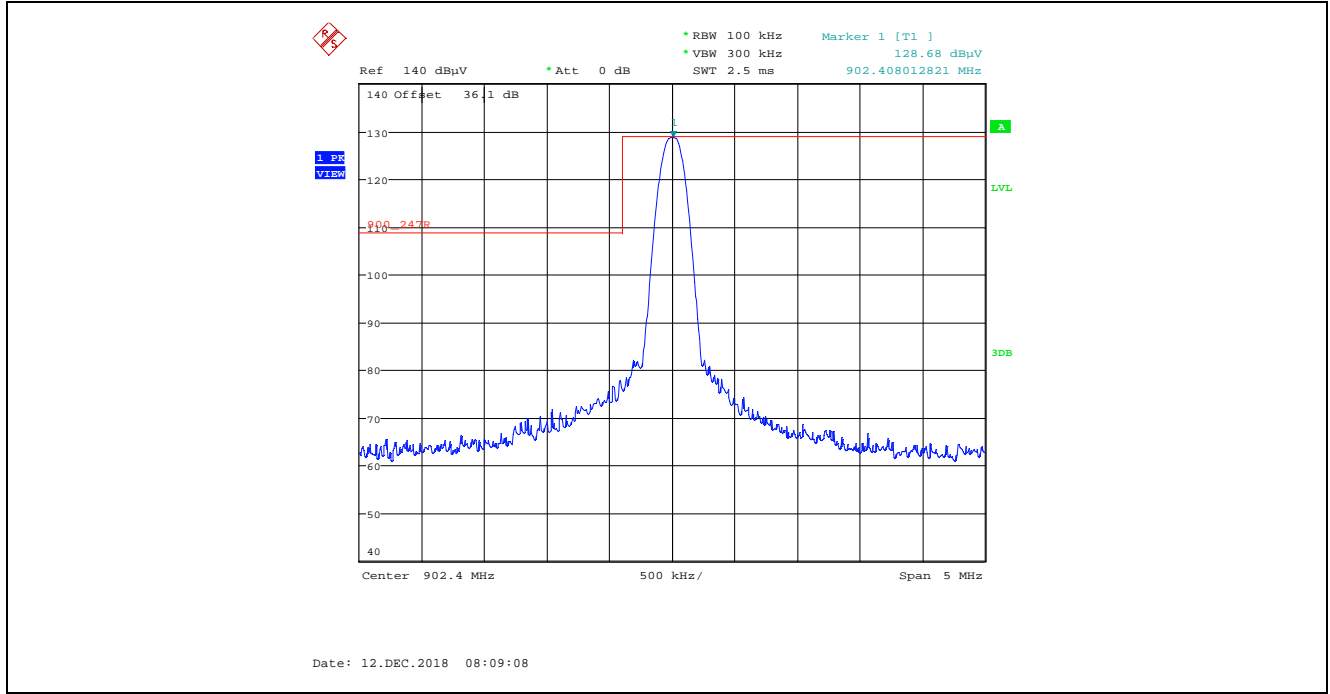

Plot 5.5.4.3.2.4. Band-Edge RF Radiated Emissions at 3 m, Vertical Polarization  
Pseudorandom Channel Hopping Mode, Low End of Frequency Band

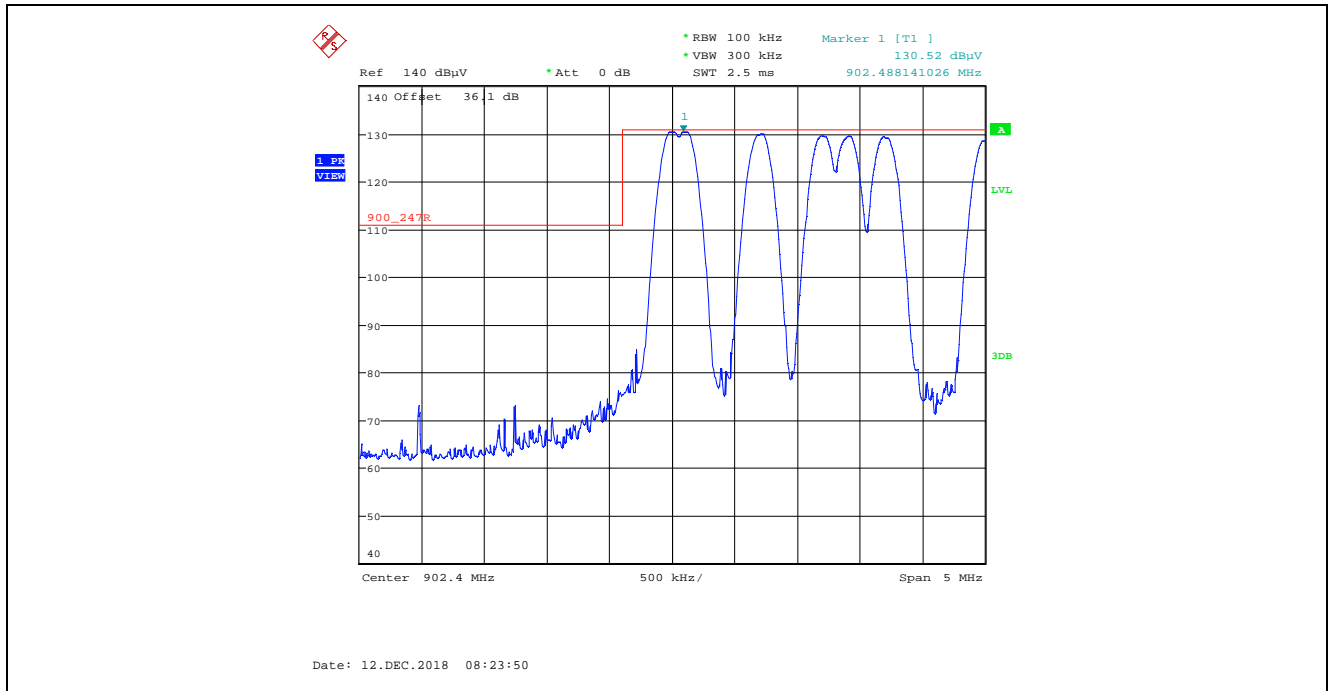

Plot 5.5.4.3.2.5. Band-Edge RF Radiated Emissions at 3 m, Horizontal Polarization  
Single Frequency Mode, High End of Frequency Band

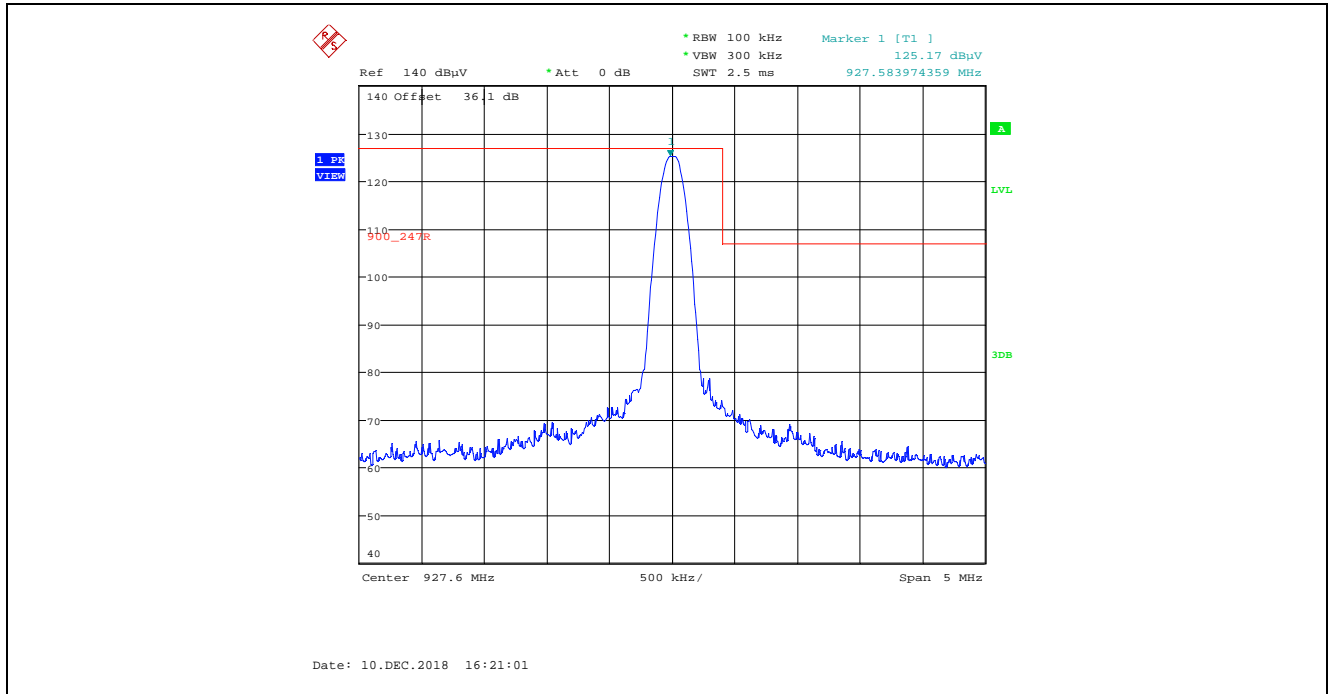

Plot 5.5.4.3.2.6. Band-Edge RF Radiated Emissions at 3 m, Horizontal Polarization  
Pseudorandom Channel Hopping Mode, High End of Frequency Band

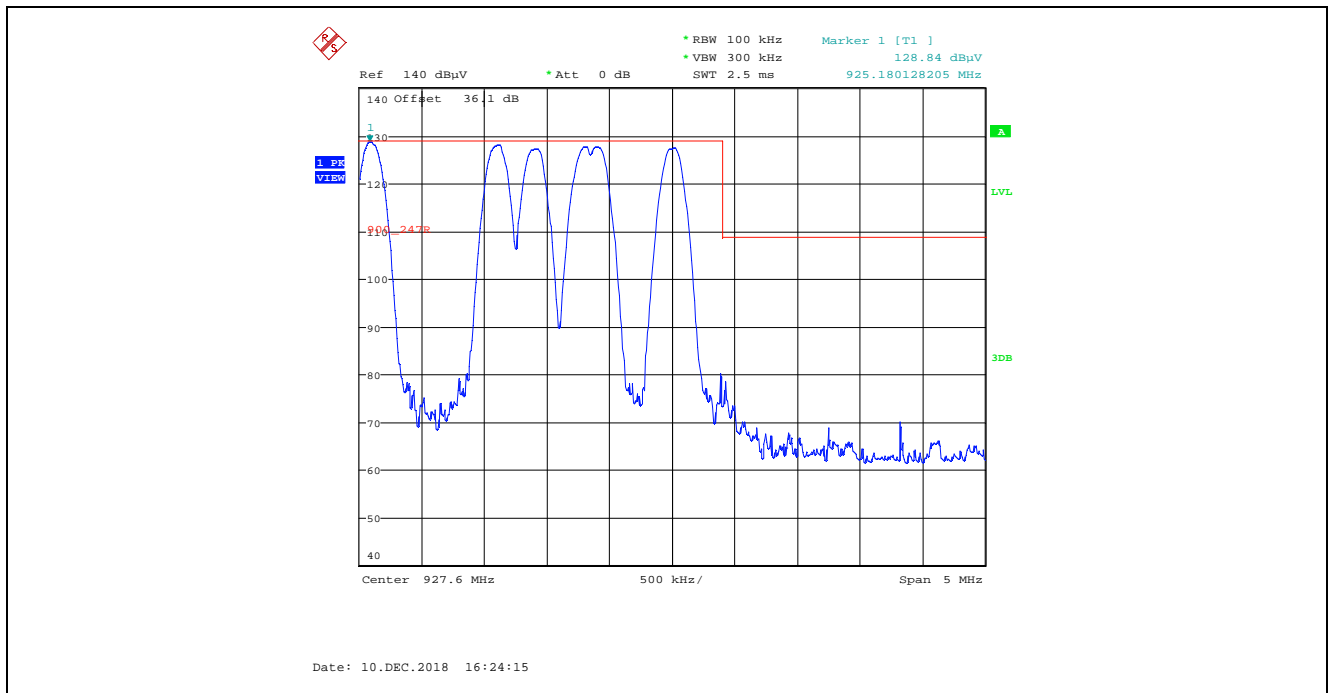



Plot 5.5.4.3.2.7. Band-Edge RF Radiated Emissions at 3 m, Vertical Polarization  
Single Frequency Mode, High of Frequency Band

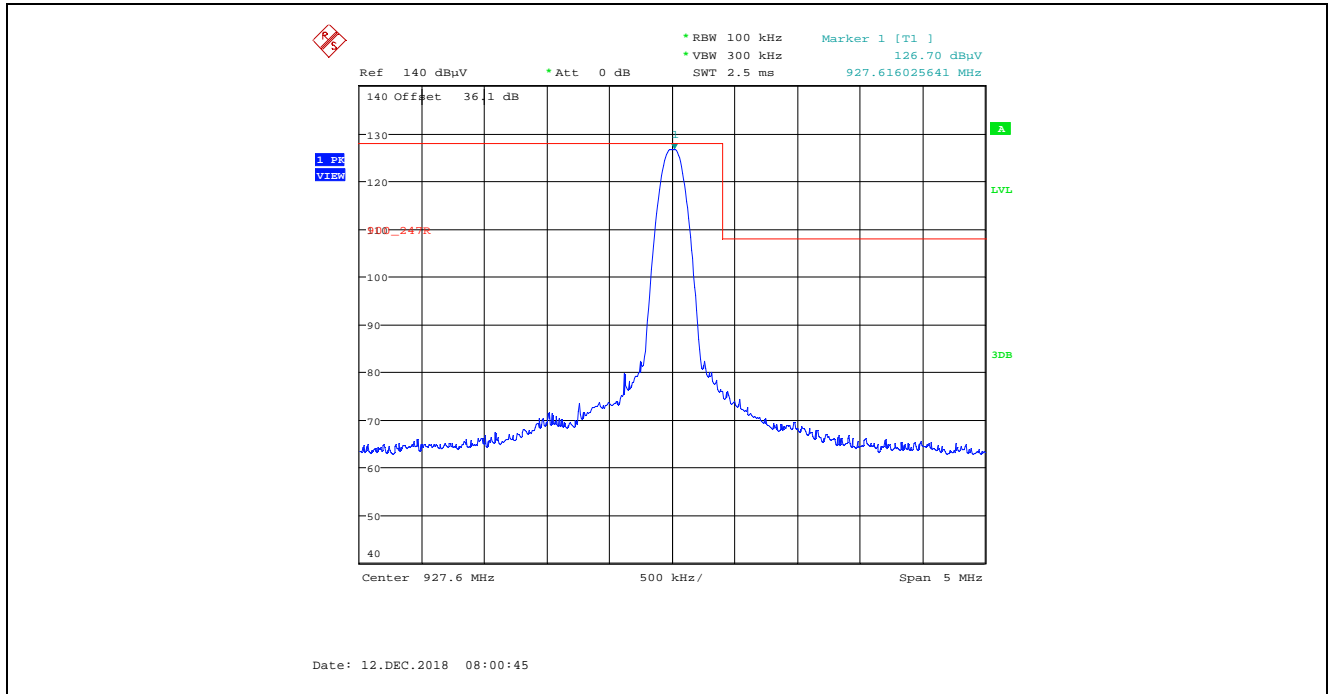

Plot 5.5.4.3.2.8. Band-Edge RF Radiated Emissions at 3 m, Vertical Polarization  
Pseudorandom Channel Hopping Mode, High End of Frequency Band

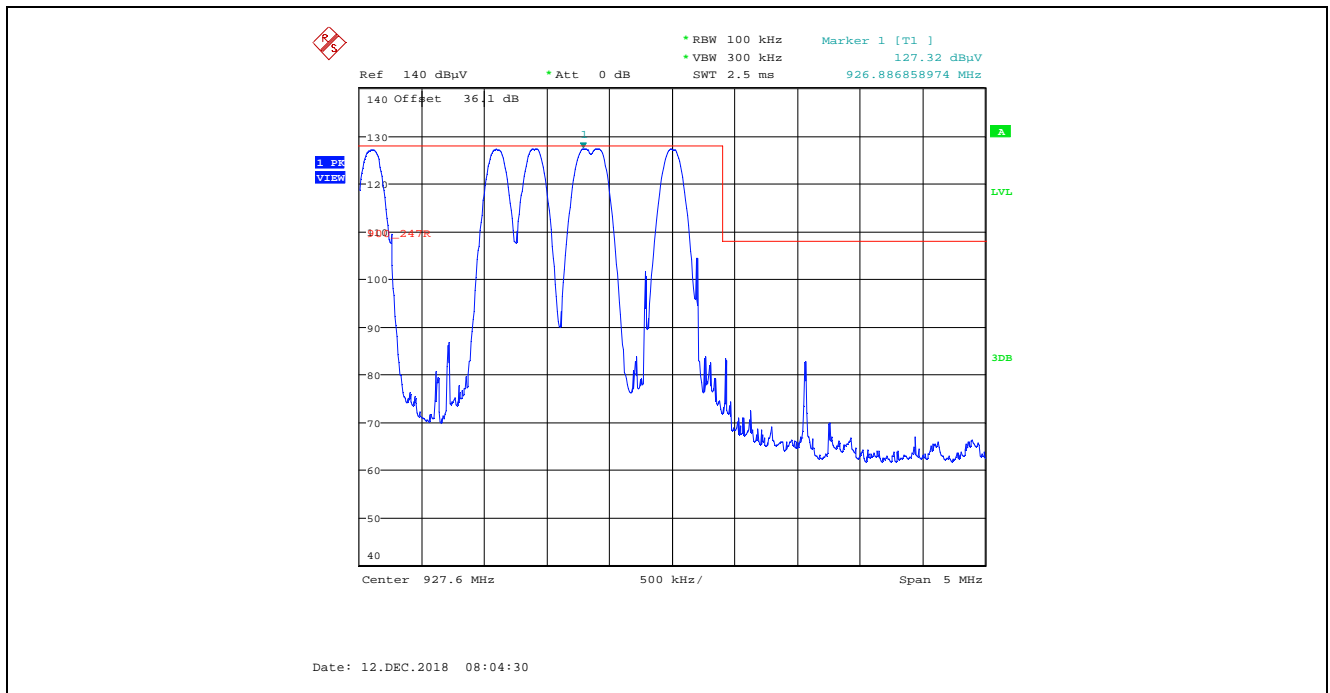

**5.5.4.4. EUT with 8.15 dBi Omni Directional Antenna, 7.67 dBi Antenna Assembly Gain, Low Data Rate**

**5.5.4.4.1. Spurious Radiated Emissions**

Fundamental Frequency:		902.4 MHz					
Raw Power Setting:		7					
Measured Conducted Power:		27.99 dBm					
Frequency Test Range:		30 MHz – 10 GHz					
Frequency (MHz)	RF Peak Level (dBµV/m)	RF Avg Level (dBµV/m)	Antenna Plane (H/V)	Limit 15.209 (dBµV/m)	Limit 15.247 (dBµV/m)	Margin (dB)	Pass/Fail
902.4	123.34	--	V	--	--	--	--
902.4	123.54	--	H	--	--	--	--
2707.2	45.64	34.26	V	54.0	103.5	-19.7	Pass*
2707.2	49.14	34.82	H	54.0	103.5	-19.2	Pass*
3609.6	47.09	36.74	H	54.0	103.5	-17.3	Pass*
All other spurious emissions and harmonics are more than 20 dB below the applicable limit.							

\*Field strength of emissions appearing within restricted frequency bands shall not exceed the limits in § 15.209.

Fundamental Frequency:		915.0 MHz					
Raw Power Setting:		7					
Measured Conducted Power:		27.99 dBm					
Frequency Test Range:		30 MHz – 10 GHz					
Frequency (MHz)	RF Peak Level (dBµV/m)	RF Avg Level (dBµV/m)	Antenna Plane (H/V)	Limit 15.209 (dBµV/m)	Limit 15.247 (dBµV/m)	Margin (dB)	Pass/Fail
915.0	122.19	--	V	--	--	--	--
915.0	123.08	--	H	--	--	--	--
2745.0	45.32	46.83	V	54.0	103.1	-7.2	Pass*
3660.0	46.81	47.35	V	54.0	103.1	-6.7	Pass*
2745.0	35.40	37.10	H	54.0	103.1	-16.9	Pass*
3660.0	33.83	35.60	H	54.0	103.1	-18.4	Pass*
All other spurious emissions and harmonics are more than 20 dB below the applicable limit.							

\*Field strength of emissions appearing within restricted frequency bands shall not exceed the limits in § 15.209.

Fundamental Frequency:		927.6 MHz					
Raw Power Setting:		7					
Measured Conducted Power:		27.29 dBm					
Frequency Test Range:		30 MHz – 10 GHz					
Frequency (MHz)	RF Peak Level (dB $\mu$ V/m)	RF Avg Level (dB $\mu$ V/m)	Antenna Plane (H/V)	Limit 15.209 (dB $\mu$ V/m)	Limit 15.247 (dB $\mu$ V/m)	Margin (dB)	Pass/Fail
927.6	121.16	--	V	--	--	--	--
927.6	123.04	--	H	--	--	--	--
2782.8	45.89	35.38	H	54.0	103.0	-18.6	Pass*
3710.4	46.74	38.32	H	54.0	103.0	-15.7	Pass*
All other spurious emissions and harmonics are more than 20 dB below the applicable limit.							

\*Field strength of emissions appearing within restricted frequency bands shall not exceed the limits in § 15.209.

5.5.4.4.2. Band –Edge RF Radiated Emissions

Plot 5.5.4.4.2.1. Band-Edge RF Radiated Emissions at 3 m, Horizontal Polarization  
Single Frequency Mode, Low End of Frequency Band

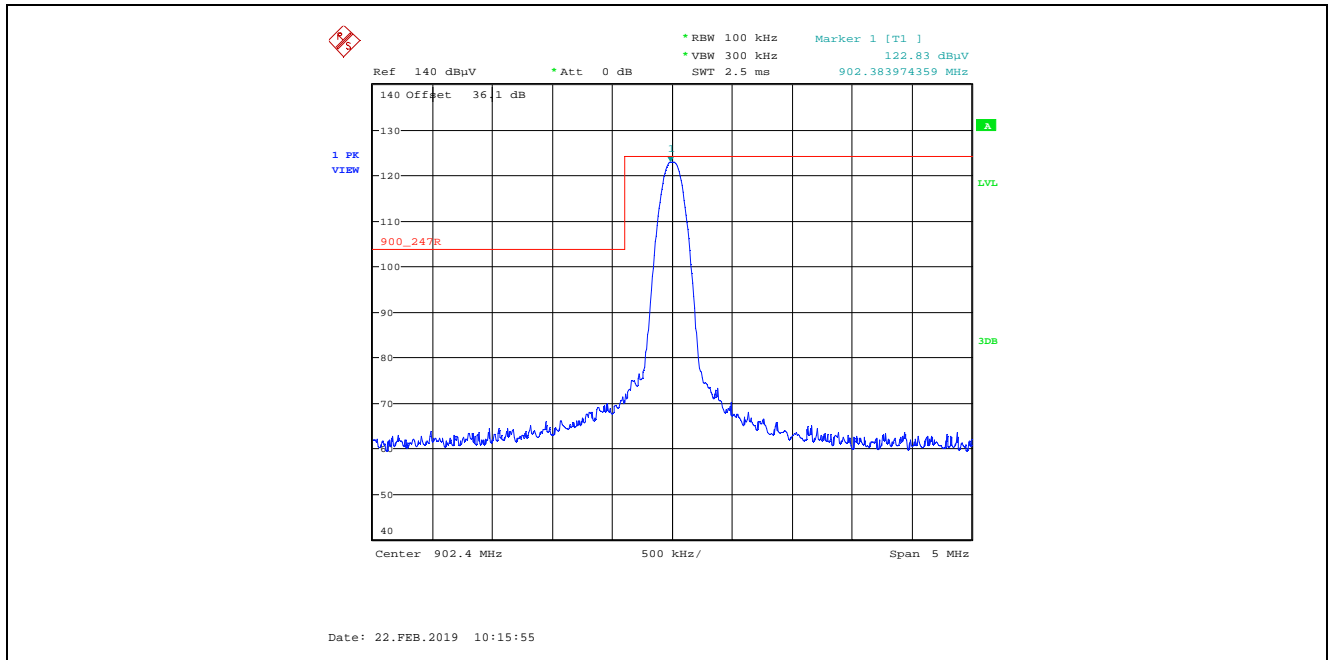

Plot 5.5.4.4.2.2. Band-Edge RF Radiated Emissions at 3 m, Horizontal Polarization  
Pseudorandom Channel Hopping Mode, Low End of Frequency Band

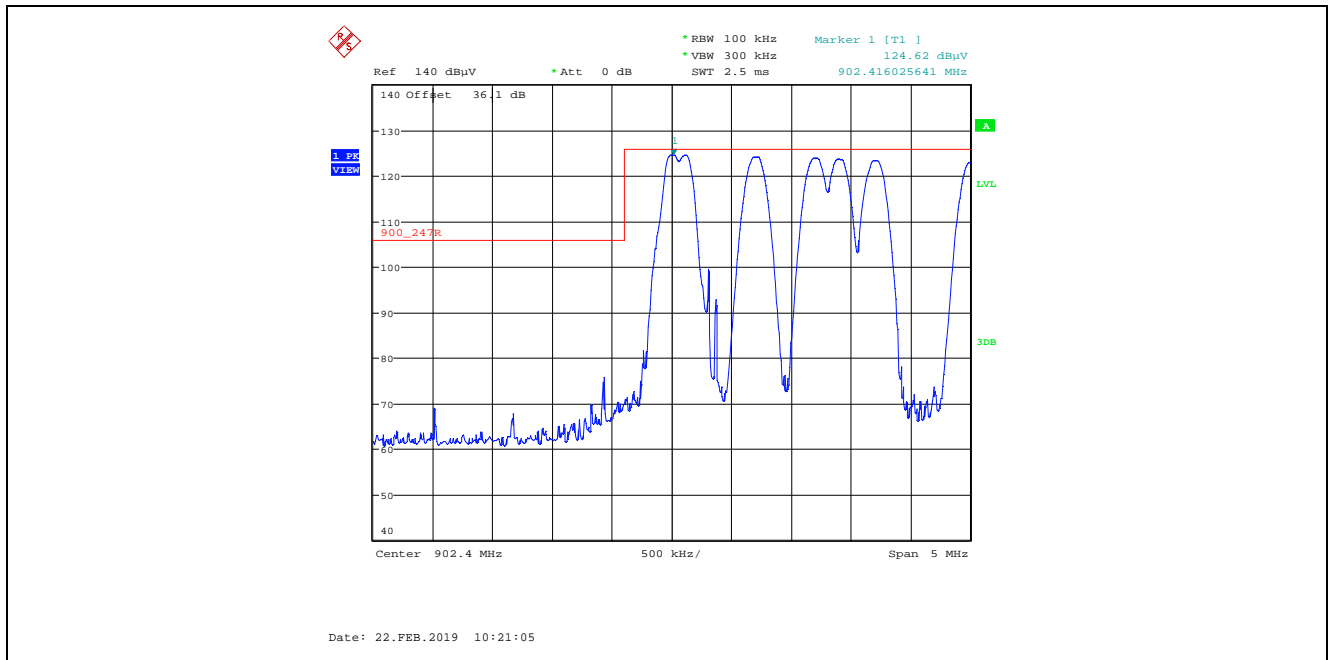

Plot 5.5.4.4.2.3. Band-Edge RF Radiated Emissions at 3 m, Vertical Polarization  
Single Frequency Mode, Low End of Frequency Band

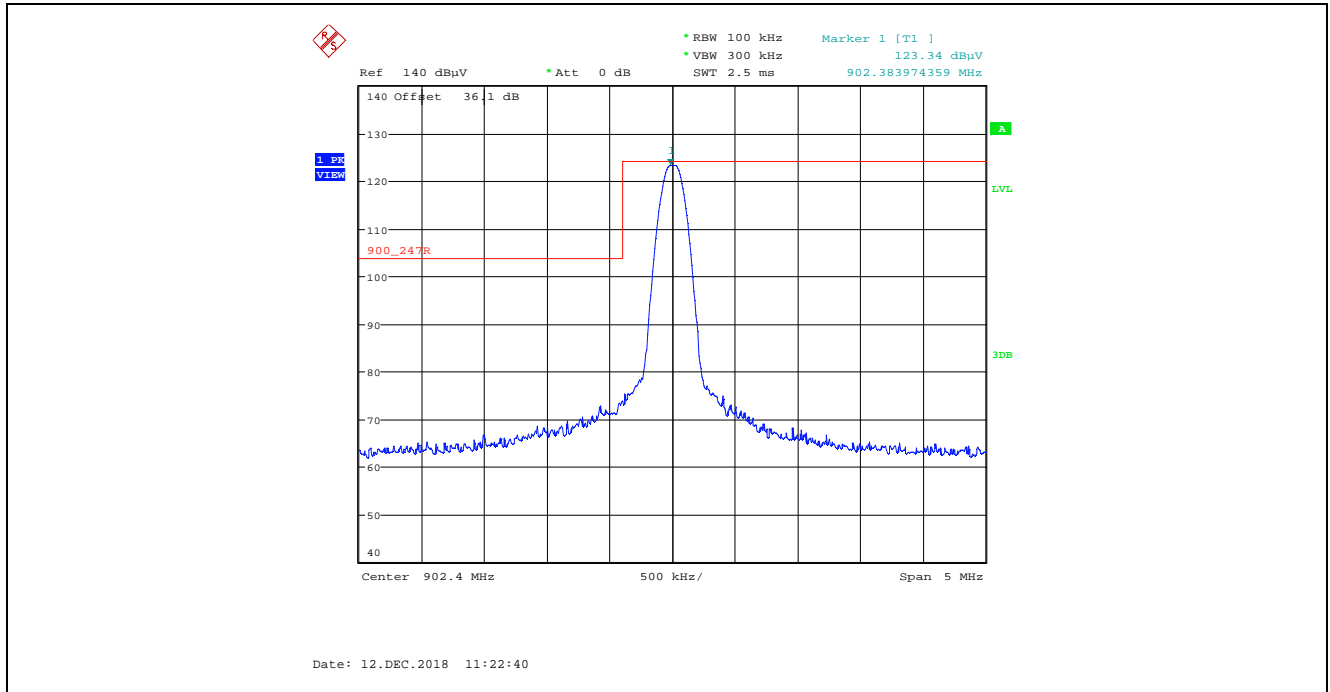

Plot 5.5.4.4.2.4. Band-Edge RF Radiated Emissions at 3 m, Vertical Polarization  
Pseudorandom Channel Hopping Mode, Low End of Frequency Band

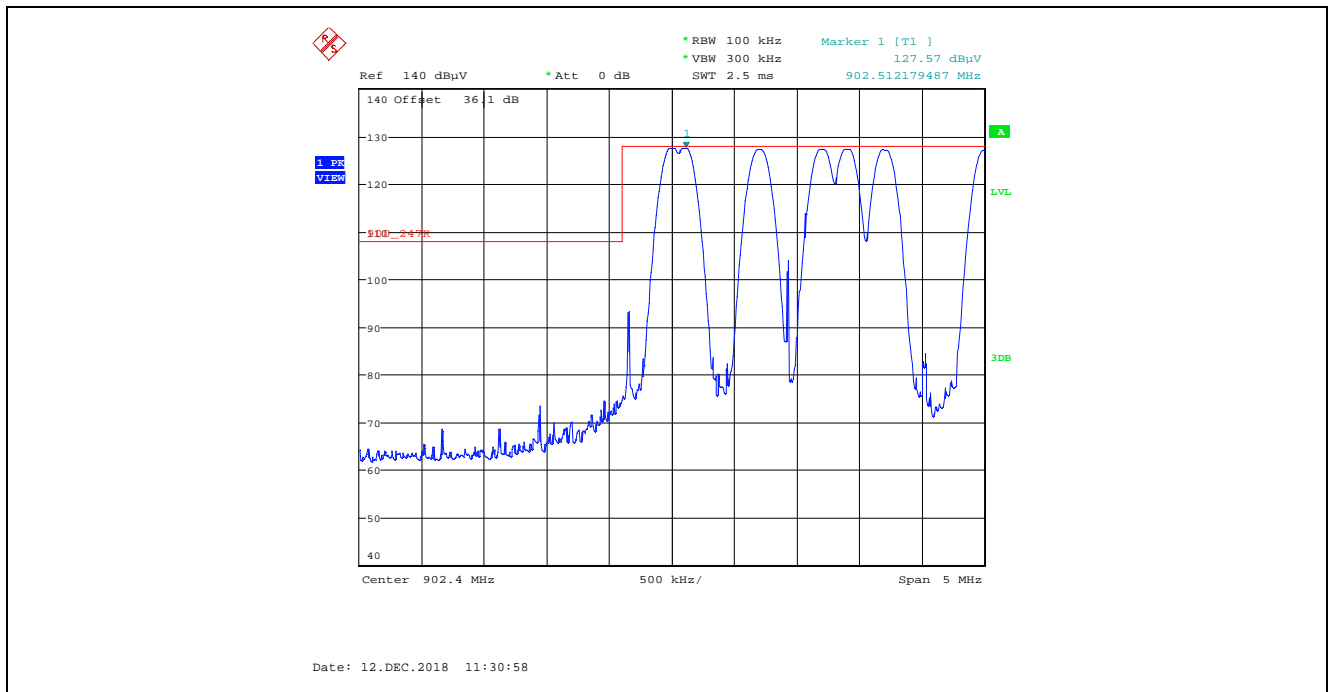

Plot 5.5.4.4.2.5. Band-Edge RF Radiated Emissions at 3 m, Horizontal Polarization  
Single Frequency Mode, High End of Frequency Band

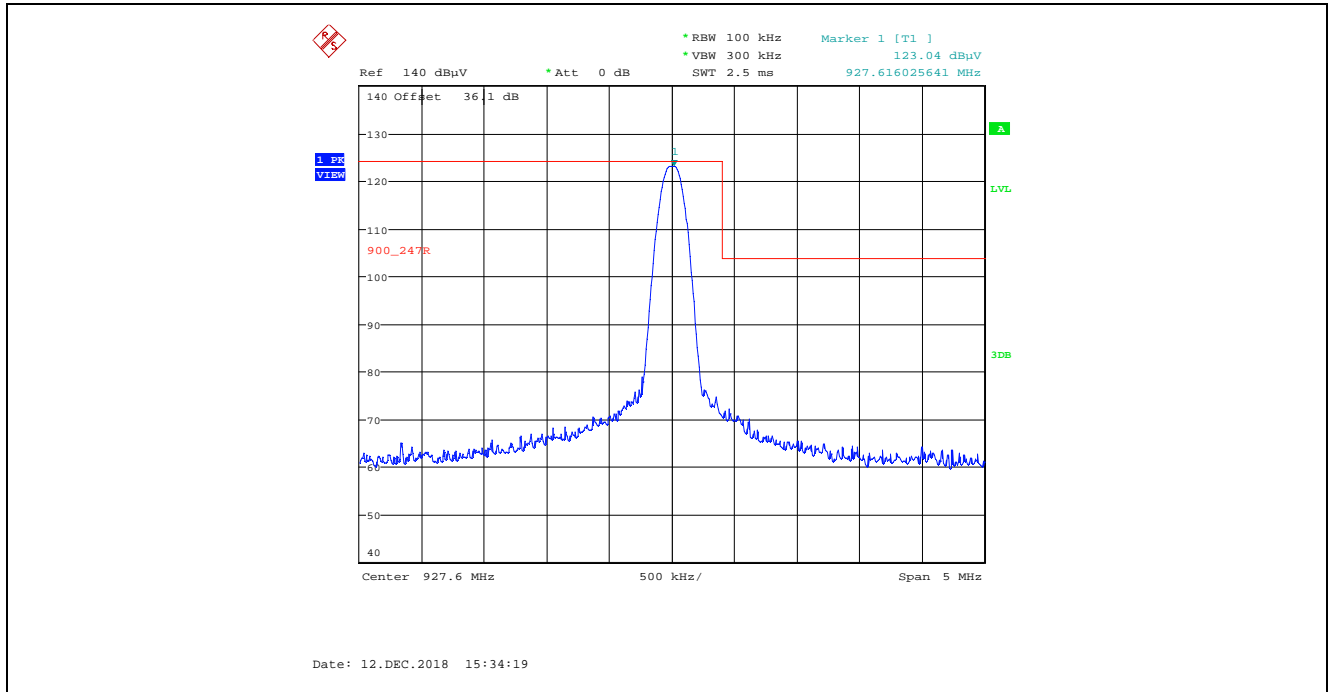

Plot 5.5.4.4.2.6. Band-Edge RF Radiated Emissions at 3 m, Horizontal Polarization  
Pseudorandom Channel Hopping Mode, High End of Frequency Band

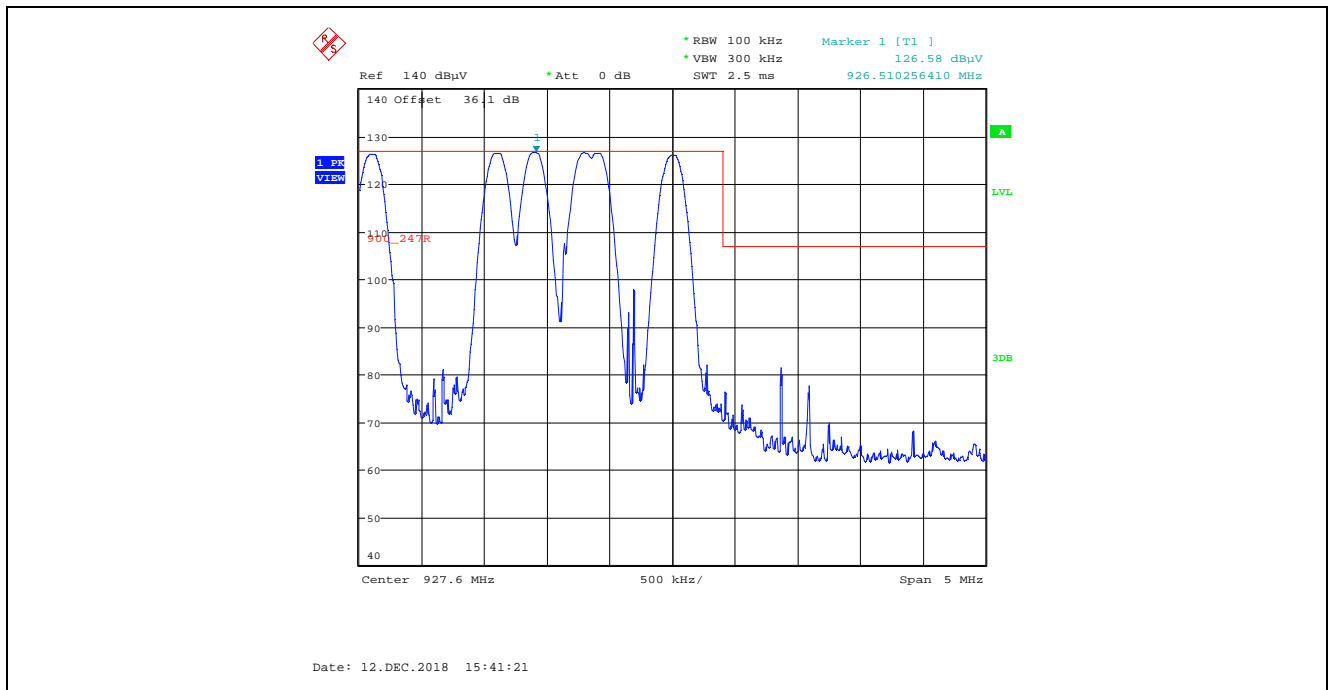

Plot 5.5.4.4.2.7. Band-Edge RF Radiated Emissions at 3 m, Vertical Polarization  
Single Frequency Mode, High of Frequency Band

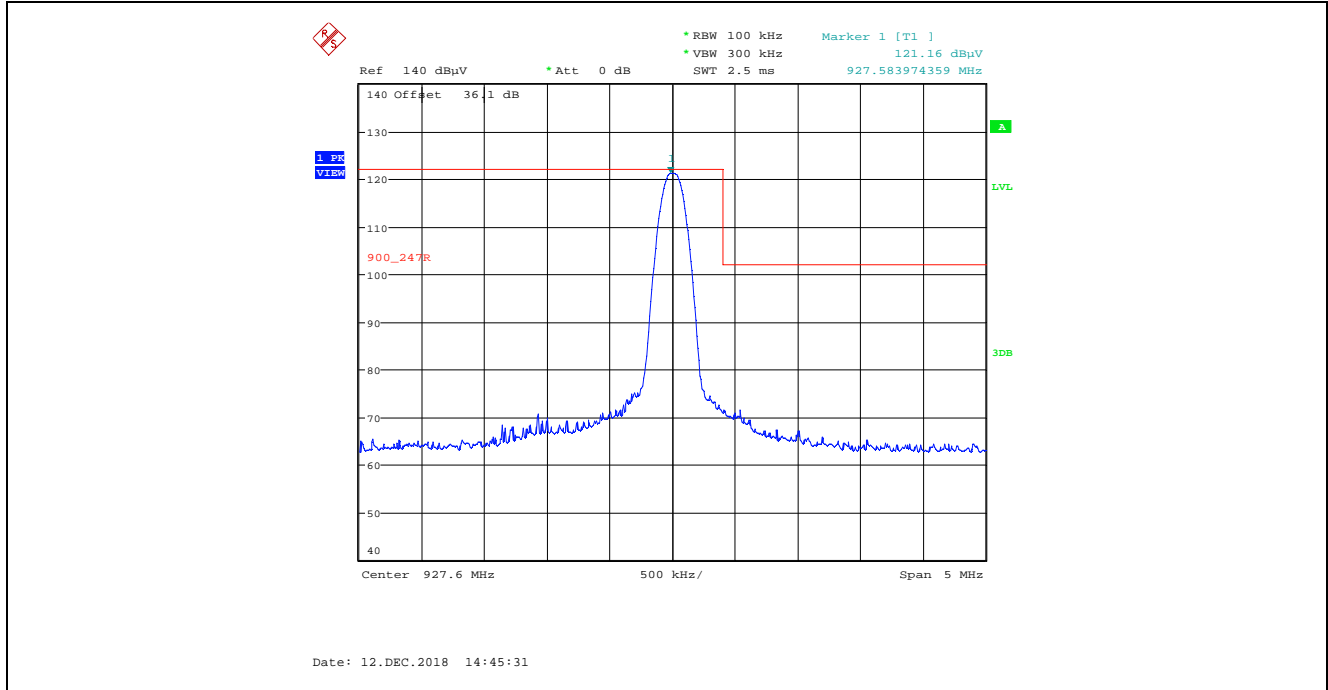

Plot 5.5.4.4.2.8. Band-Edge RF Radiated Emissions at 3 m, Vertical Polarization  
Pseudorandom Channel Hopping Mode, High End of Frequency Band

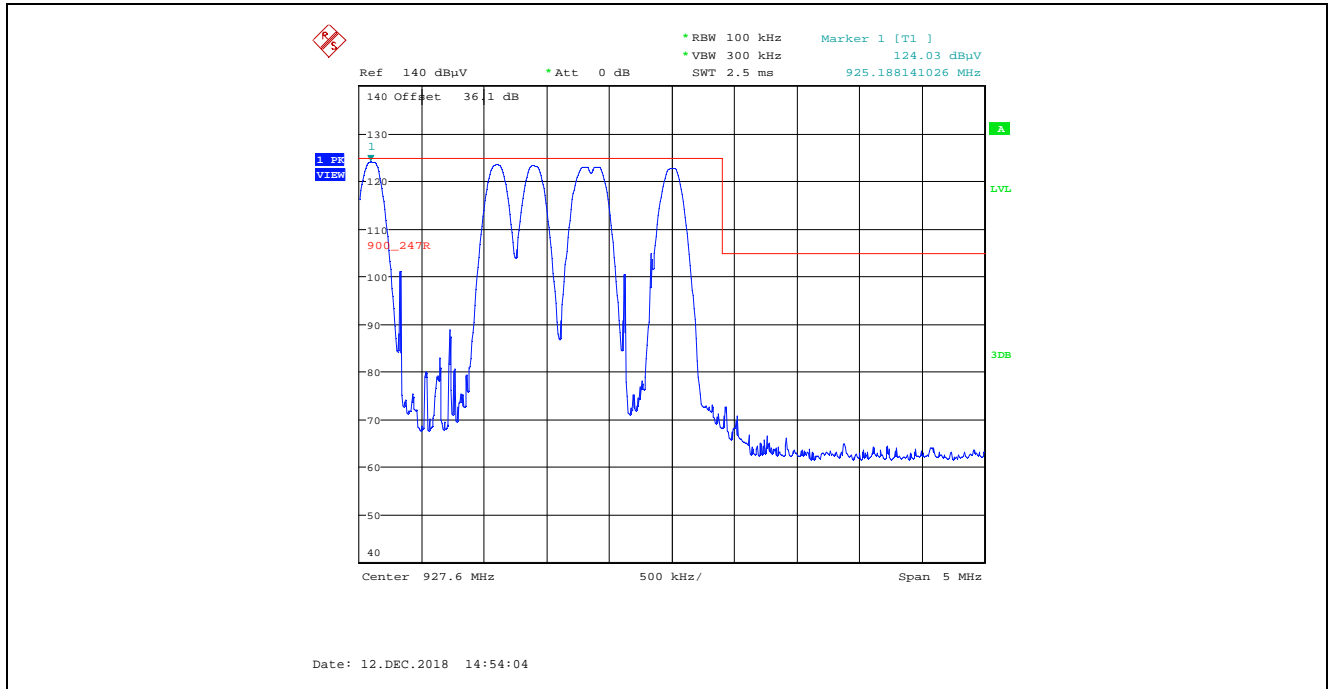

**5.5.4.5. EUT with 4 dBi Puck Antenna, 4 dBi Antenna Assembly Gain, Low Data Rate**

**5.5.4.5.1. Spurious Radiated Emissions**

Fundamental Frequency:		902.4 MHz					
Raw Power Setting:		10					
Measured Conducted Power:		29.96 dBm					
Frequency Test Range:		30 MHz – 10 GHz					
Frequency (MHz)	RF Peak Level (dBµV/m)	RF Avg Level (dBµV/m)	Antenna Plane (H/V)	Limit 15.209 (dBµV/m)	Limit 15.247 (dBµV/m)	Margin (dB)	Pass/Fail
902.4	126.65	--	V	--	--	--	--
902.4	124.01	--	H	--	--	--	--
2707.2	48.29	41.61	V	54.0	106.7	-12.4	Pass*
2707.2	47.97	40.09	H	54.0	106.7	-13.9	Pass*
3609.6	47.94	37.96	V	54.0	106.7	-16.0	Pass*
3609.6	47.56	37.41	H	54.0	106.7	-16.6	Pass*
4512.0	48.20	35.20	V	54.0	106.7	-18.8	Pass*
4512.0	48.68	35.33	H	54.0	106.7	-18.7	Pass*
8121.6	54.38	42.61	V	54.0	106.7	-11.4	Pass*
8121.6	55.85	42.93	H	54.0	106.7	-11.1	Pass*
9024.0	55.63	42.82	V	54.0	106.7	-11.2	Pass*
9024.0	57.39	43.58	H	54.0	106.7	-10.4	Pass*
All other spurious emissions and harmonics are more than 20 dB below the applicable limit.							

\*Field strength of emissions appearing within restricted frequency bands shall not exceed the limits in § 15.209.



Fundamental Frequency:		915.0 MHz					
Raw Power Setting:		10					
Measured Conducted Power:		29.99 dBm					
Frequency Test Range:		30 MHz – 10 GHz					
Frequency (MHz)	RF Peak Level (dBµV/m)	RF Avg Level (dBµV/m)	Antenna Plane (H/V)	Limit 15.209 (dBµV/m)	Limit 15.247 (dBµV/m)	Margin (dB)	Pass/Fail
915.0	125.66	--	V	--	--	--	--
915.0	123.44	--	H	--	--	--	--
2745.0	50.72	45.11	V	54.0	105.7	-8.9	Pass*
2745.0	51.64	46.93	H	54.0	105.7	-7.1	Pass*
3660.0	49.44	40.06	V	54.0	105.7	-13.9	Pass*
3660.0	51.24	42.25	H	54.0	105.7	-11.8	Pass*
4575.0	49.45	36.02	V	54.0	105.7	-18.0	Pass*
4575.0	49.43	35.87	H	54.0	105.7	-18.1	Pass*
7320.0	55.33	44.83	V	54.0	105.7	-9.2	Pass*
7320.0	54.70	43.84	H	54.0	105.7	-10.2	Pass*
8235.0	54.60	41.68	V	54.0	105.7	-12.3	Pass*
8235.0	55.56	43.00	H	54.0	105.7	-11.0	Pass*
9150.0	58.00	46.14	V	54.0	105.7	-7.9	Pass*
9150.0	59.17	50.31	H	54.0	105.7	-3.7	Pass*
All other spurious emissions and harmonics are more than 20 dB below the applicable limit.							

\*Field strength of emissions appearing within restricted frequency bands shall not exceed the limits in § 15.209.

Fundamental Frequency:		927.6 MHz					
Raw Power Setting:		10					
Measured Conducted Power:		29.94 dBm					
Frequency Test Range:		30 MHz – 10 GHz					
Frequency (MHz)	RF Peak Level (dBµV/m)	RF Avg Level (dBµV/m)	Antenna Plane (H/V)	Limit 15.209 (dBµV/m)	Limit 15.247 (dBµV/m)	Margin (dB)	Pass/Fail
927.6	124.72	--	V	--	--	--	--
927.6	116.07	--	H	--	--	--	--
2782.8	48.85	42.79	V	54.0	104.7	-11.2	Pass*
2782.8	50.40	44.55	H	54.0	104.7	-9.5	Pass*
3710.4	48.33	36.78	V	54.0	104.7	-17.2	Pass*
3710.4	48.33	36.83	H	54.0	104.7	-17.2	Pass*
4638.0	49.04	35.80	V	54.0	104.7	-18.2	Pass*
4638.0	50.36	38.78	H	54.0	104.7	-15.2	Pass*
7420.8	55.72	45.13	V	54.0	104.7	-8.9	Pass*
7420.8	55.19	43.71	H	54.0	104.7	-10.3	Pass*
8348.4	54.89	42.20	V	54.0	104.7	-11.8	Pass*
8348.4	55.25	42.80	H	54.0	104.7	-11.2	Pass*
All other spurious emissions and harmonics are more than 20 dB below the applicable limit.							

\*Field strength of emissions appearing within restricted frequency bands shall not exceed the limits in § 15.209.

5.5.4.5.2. Band –Edge RF Radiated Emissions

Plot 5.5.4.5.2.1. Band-Edge RF Radiated Emissions at 3 m, Horizontal Polarization  
Single Frequency Mode, Low End of Frequency Band

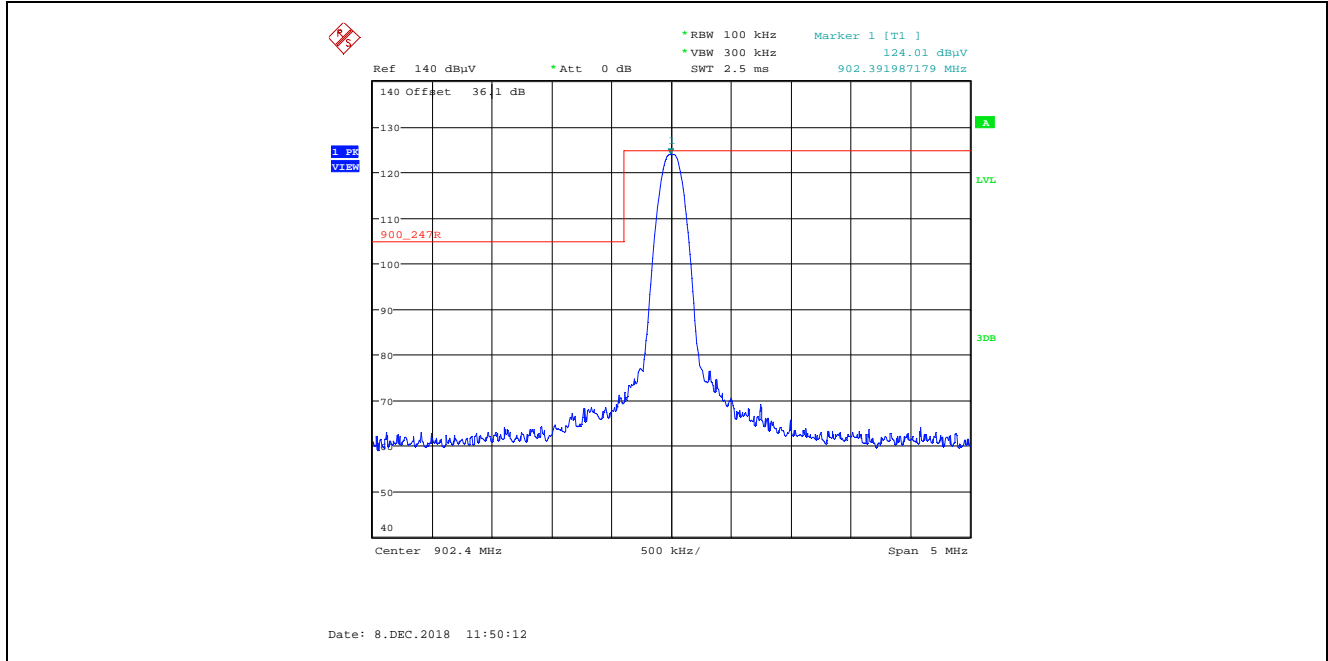

Plot 5.5.4.5.2.2. Band-Edge RF Radiated Emissions at 3 m, Horizontal Polarization  
Pseudorandom Channel Hopping Mode, Low End of Frequency Band

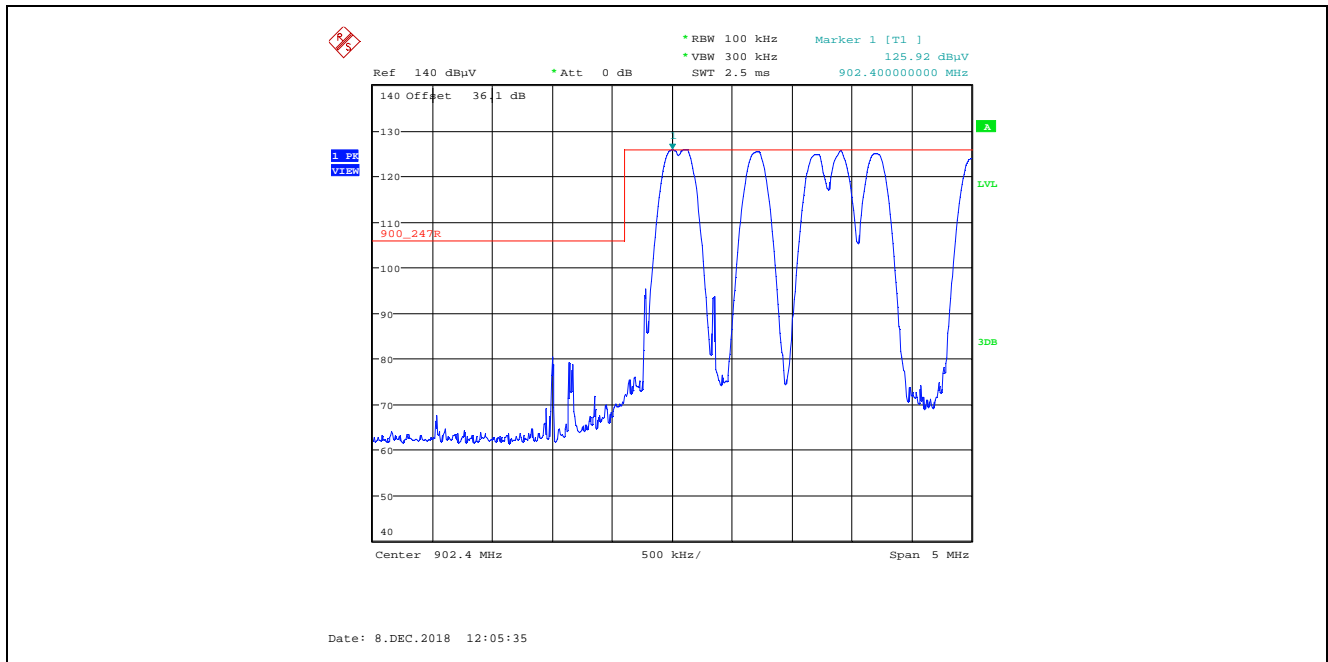

Plot 5.5.4.5.2.3. Band-Edge RF Radiated Emissions at 3 m, Vertical Polarization  
Single Frequency Mode, Low End of Frequency Band

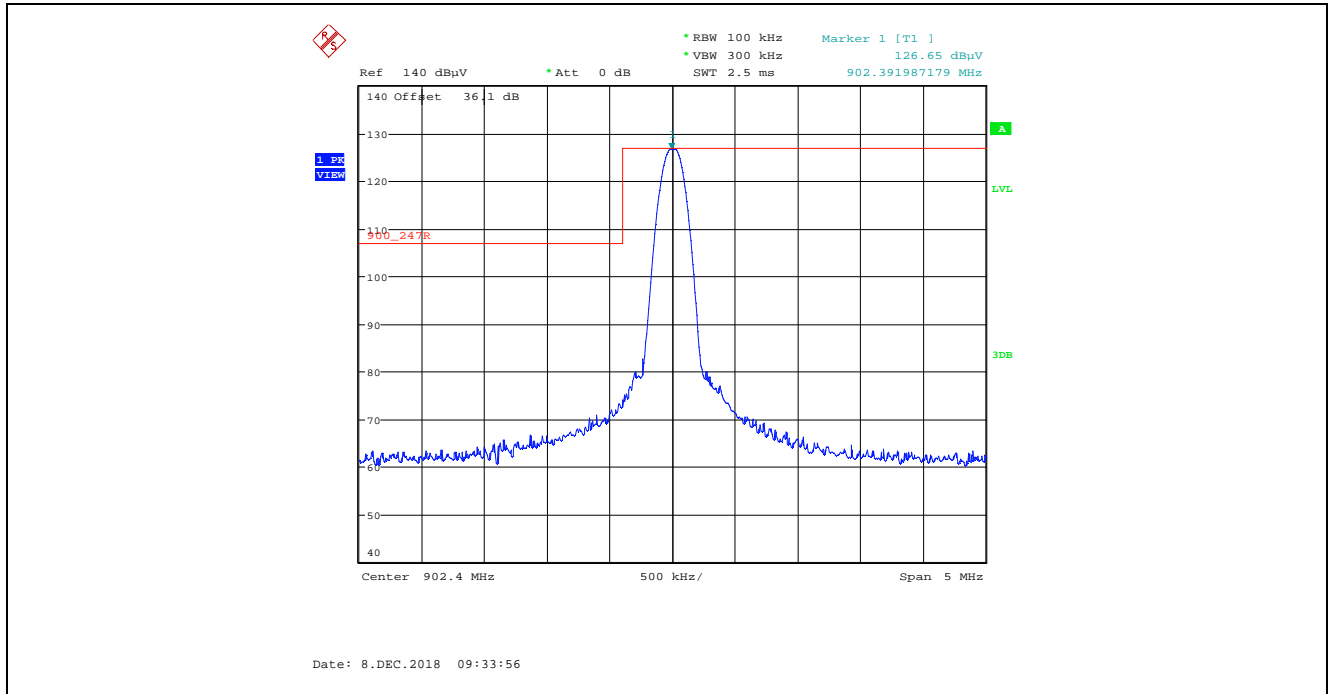

Plot 5.5.4.5.2.4. Band-Edge RF Radiated Emissions at 3 m, Vertical Polarization  
Pseudorandom Channel Hopping Mode, Low End of Frequency Band

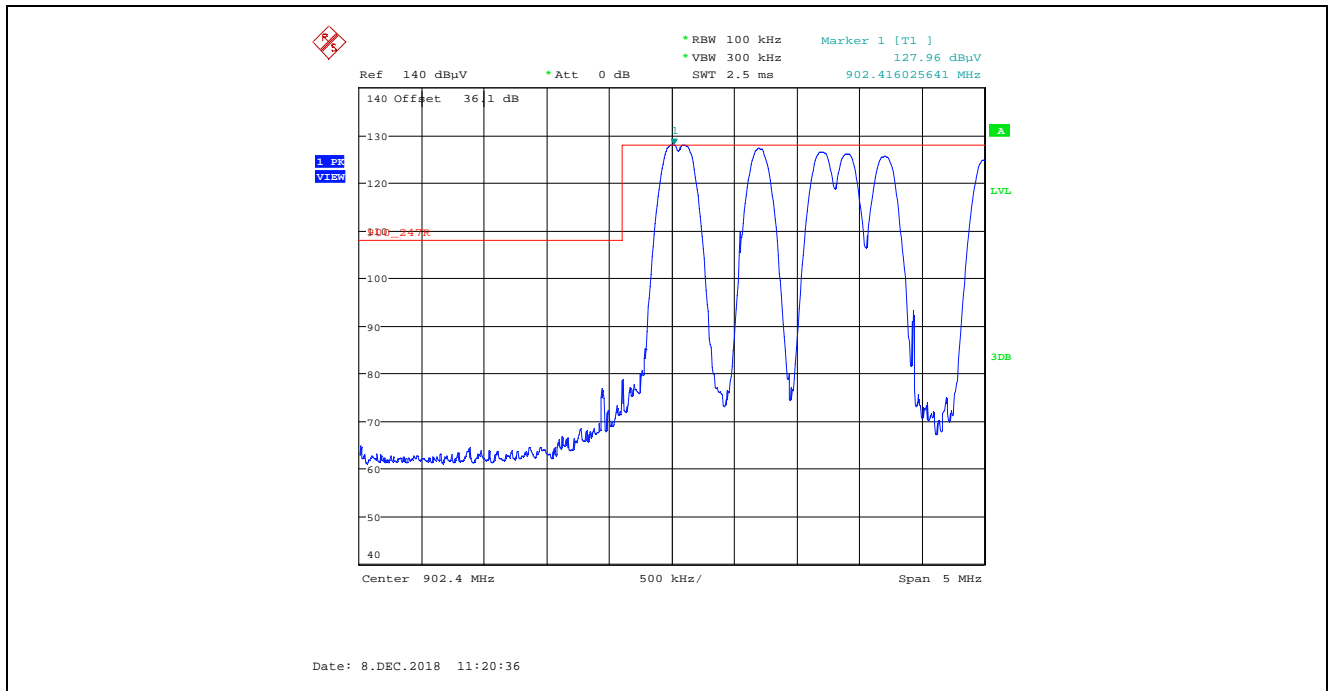

**Plot 5.5.4.5.2.5.** Band-Edge RF Radiated Emissions at 3 m, Horizontal Polarization  
 Single Frequency Mode, High End of Frequency Band

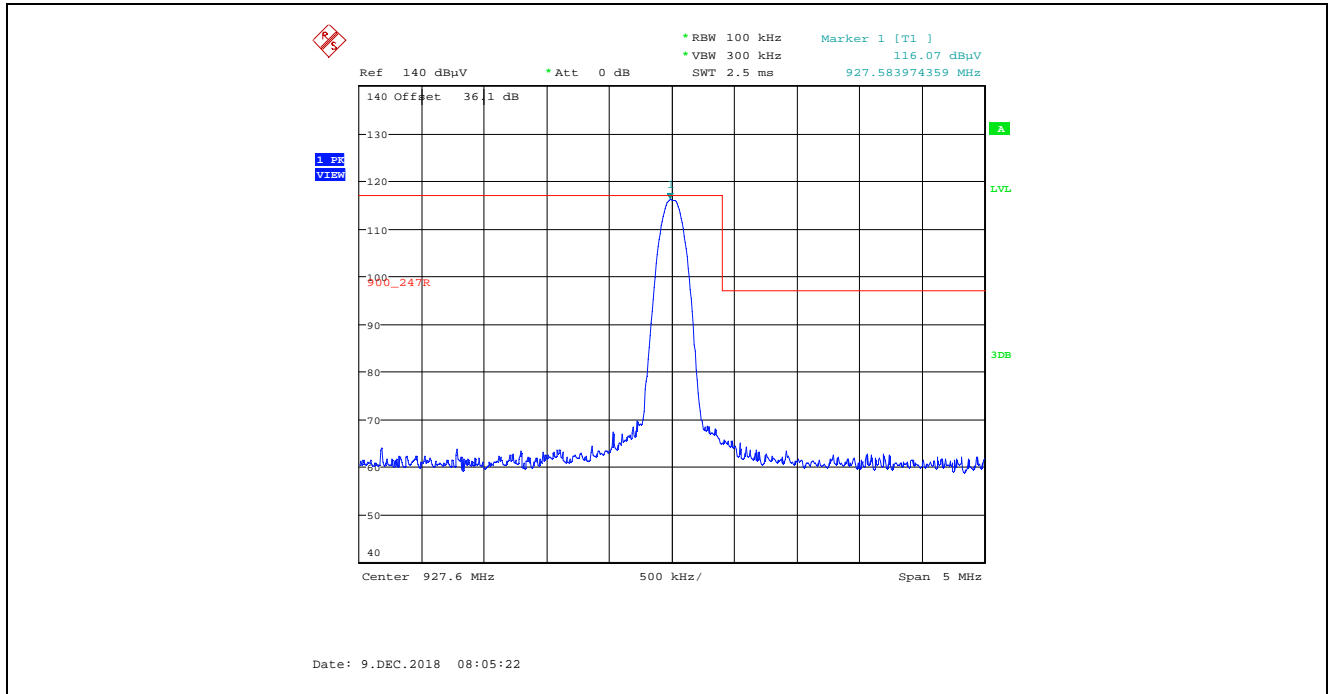

**Plot 5.5.4.5.2.6.** Band-Edge RF Radiated Emissions at 3 m, Horizontal Polarization  
 Pseudorandom Channel Hopping Mode, High End of Frequency Band

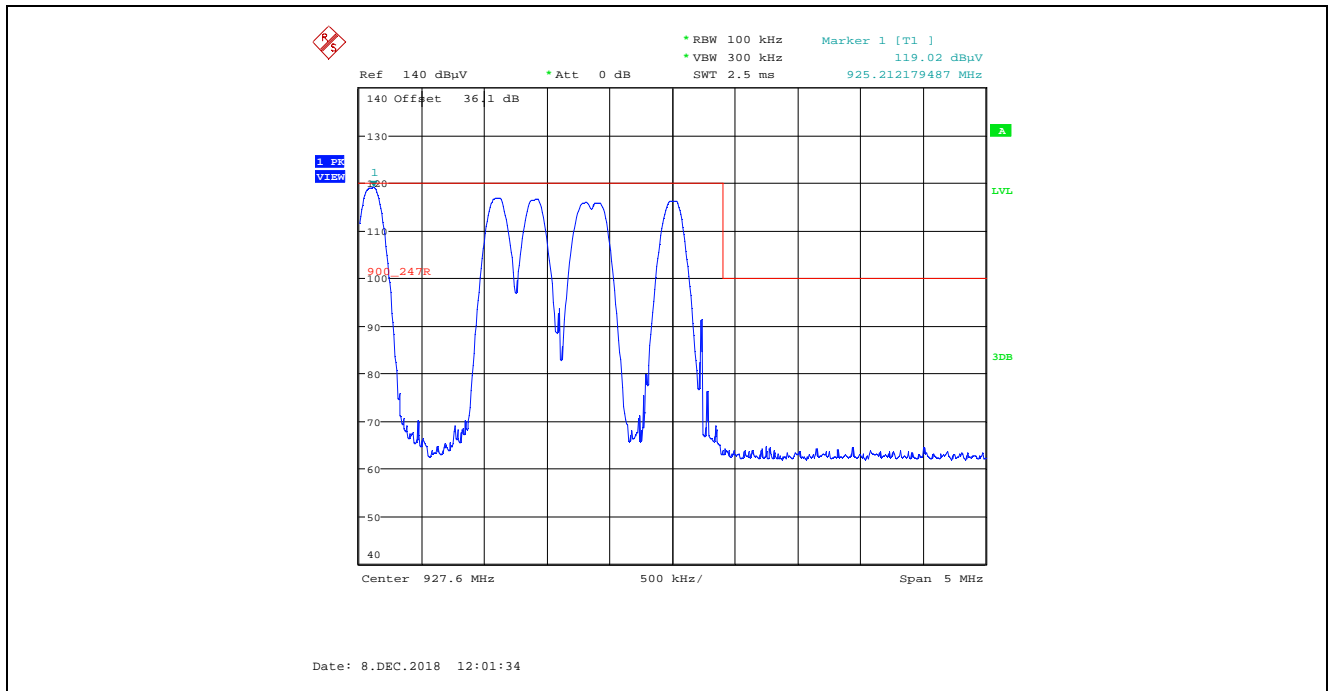

Plot 5.5.4.5.2.7. Band-Edge RF Radiated Emissions at 3 m, Vertical Polarization  
Single Frequency Mode, High of Frequency Band

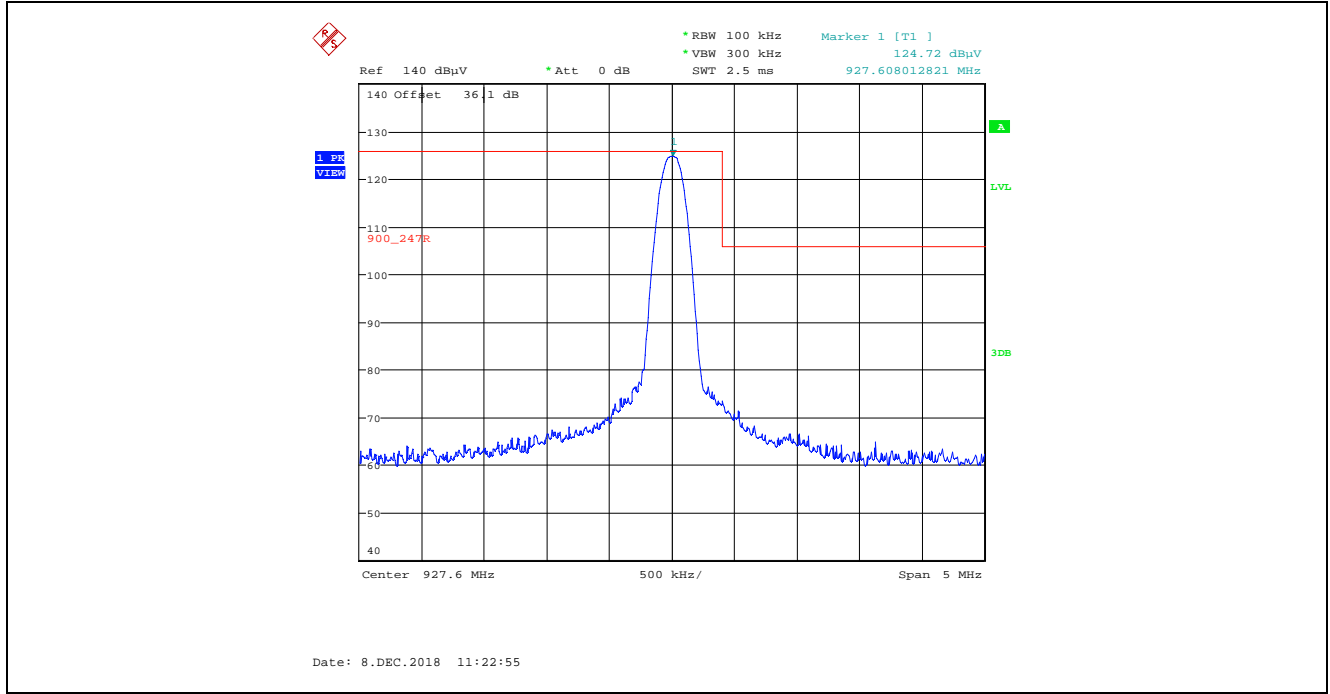

Plot 5.5.4.5.2.8. Band-Edge RF Radiated Emissions at 3 m, Vertical Polarization  
Pseudorandom Channel Hopping Mode, High End of Frequency Band

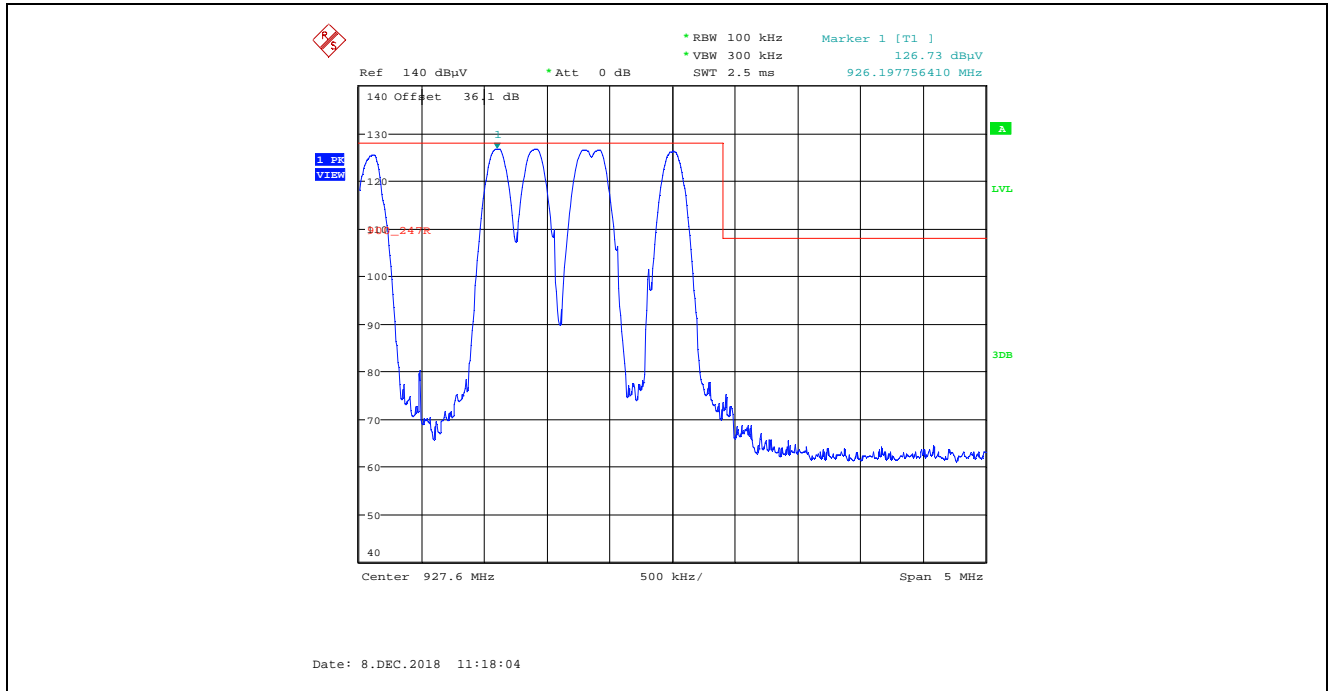

**5.6. RF EXPOSURE REQUIRMENTS [§§ 15.247(i), 1.1310 & 2.1091]**

§ 1.1310: The criteria listed in the following table shall be used to evaluate the environmental impact of human exposure to radio-frequency (RF) radiation as specified in 1.1307(b).

**Limits for Maximum Permissible Exposure (MPE)**

Frequency range (MHz)	Electric field strength (V/m)	Magnetic field strength (A/m)	Power density (mW/cm <sup>2</sup> )	Averaging time (minutes)
<b>(A) Limits for Occupational/Controlled Exposures</b>				
0.3-3.0	614	1.63	*(100)	6
3.0-30	1842/f	4.89/f	*(900/f <sup>2</sup> )	6
30-300	61.4	0.163	1.0	6
300-1500			f/300	6
1500-100,000			5	6
<b>(B) Limits for General Population/Uncontrolled Exposure</b>				
0.3-1.34	614	1.63	*(100)	30
1.34-30	824/f	2.19/f	*(180/f <sup>2</sup> )	30
30-300	27.5	0.073	0.2	30
300-1500			f/1500	30
1500-100,000			1.0	30

f = frequency in MHz

\* = Plane-wave equivalent power density

Note 1: Occupational/controlled limits apply in situations in which persons are exposed as a consequence of their employment provided those persons are fully aware of the potential for exposure and can exercise control over their exposure. Limits for occupational/controlled exposure also apply in situations when an individual is transient through a location where occupational/controlled limits apply provided he or she is made aware of the potential for exposure.

Note 2: General population/uncontrolled exposures apply in situations in which the general public may be exposed, or in which persons that are exposed as a consequence of their employment may not be fully aware of the potential for exposure or can not exercise control over their exposure.

**5.6.1. Method of Measurements**

Calculation Method of Power Density/RF Safety Distance:

$$S = \frac{PG}{4\pi \cdot r^2} = \frac{EIRP}{4\pi \cdot r^2}$$

Where,  
 P: power input to the antenna in mW  
 EIRP: Equivalent (effective) isotropic radiated power.  
 S: power density mW/cm<sup>2</sup>  
 G: numeric gain of antenna relative to isotropic radiator  
 r: distance to centre of radiation in cm

**5.6.2. RF Evaluation**

**5.6.2.1. Standalone**

Frequency (MHz)	EIRP (dBm)	EIRP (mW)	Evaluation Distance, r (cm)	Power Density, S (mW/cm <sup>2</sup> )	MPE Limit (mW/cm <sup>2</sup> )	Margin (mW/cm <sup>2</sup> )
902.4	36	3981.072	35	0.259	0.602	-0.343

**5.6.2.2. Co-location**

Pursuant to KDB 447498 D01 General RF Exposure Guidance v06, Section 7.2:

*Simultaneous transmission MPE test exclusion applies when the sum of the MPE ratios for all simultaneously transmitting antennas incorporated in a host device is ≤ 1.0, according to calculated/estimated, numerically modeled, or measured field strengths or power density.*

Co-location will only apply to EUT with 3 dBi dipole antenna, worst case EIRP of 33 dBm will be used in co-location at the minimum 35 cm evaluation separation distance required by the operating configurations and exposure conditions of the host device.

**The maximum calculated MPE ratio of the EUT with 3 dBi dipole antenna (rubber ducky antenna)**

Frequency (MHz)	EUT EIRP (dBm)	EUT EIRP (mW)	Evaluation Distance (cm)	Power Density (mW/cm <sup>2</sup> )	FCC MPE Limit (mW/cm <sup>2</sup> )	MPE Ratio
902.4	33	1995.262	35	0.130	0.602	0.216

The maximum calculated MPE ratio for the EUT with 3 dBi dipole antenna is 0.216, this configuration can be co-located with other antennas provided the sum of the MPE ratios for all the other simultaneous transmitting antennas incorporated in a host device is ≤ 1.0 - 0.216 ≤ 0.784.

The following table addresses the co-location of the EUT with 3 dBi antenna with the specified radio modules.

**EUT with 3 dBi dipole antenna co-location with radio module identified in this table**

*Radio Module	Frequency (MHz)	EIRP (dBm)	EIRP (mW)	Evaluation Distance (cm)	Power Density (mW/cm <sup>2</sup> )	FCC MPE Limit (mW/cm <sup>2</sup> )	MPE Ratio	MPE Ratio of EUT with 2.5 dBi antenna	Sum of MPE Ratio	Verdict
LE910NA V2 LTE/3G Module (FCC ID: RI7LE910NAV2, IC: 5131A-LE910NAV2)	699.0	30.63	1156.112	35	0.075	0.466	0.161	0.216	0.377	Compliant
LM940 Module (FCC ID: RI7LM940 IC: 5131A-LM940)	2307.5	34.00	2511.886	35	0.163	1.000	0.163	0.216	0.379	Compliant
SARA-R410M LTE Cat-M1 Module (FCC ID: XPY2AGQN4NNN, IC: 8595A-2AGQN4NNN)	1850.0	32.12	1629.296	35	0.106	1.000	0.106	0.216	0.322	Compliant
L850 LTE Module (FCC ID: ZMOL850GL, IC: 21374-L850GL)	826.4	--	501.19	35	0.033	0.551	0.060	0.216	0.276	Compliant

\* The test data of the radio modules represented in this table is the worst-case configuration (maximum MPE ratio) derived from the original radio modules MPE reports. Refer to these reports for detail.



**EXHIBIT 6. TEST EQUIPMENT LIST**

Test Instruments	Manufacturer	Model No.	Serial No.	Frequency Range	Cal. Due Date
Spectrum Analyzer	Hewlett Packard	HP 8593EM	3412A00103	9 kHz–26.5 GHz	22 May 2019
Attenuator	Pasternack	PE7010-20	ATT13	DC–2 GHz	21 Mar 2019
LISN Used	EMCO	3825/2R	1165	10 kHz–30 MHz	18 Oct 2019
Attenuator	Pasternack	PE7024-20	6	DC–26.5 GHz	See Note 1
DC Block	Hewlett Packard	11742A	12460	0.045–26.5 GHz	See Note 1
Spectrum Analyzer	Rohde & Schwarz	FSU26	200946	20Hz–26.5 GHz	25 Jul 2020
EMI Receiver	Rohde & Schwarz	ESU40	100037	20Hz–40 GHz	04 May 2019
RF Amplifier	Com-Power	PAM-0118A	551052	0.5 – 18 GHz	26 Jun 2019
RF Amplifier	Hewlett Packard	84498	3008A00769	1 – 26.5 GHz	01 Oct 2019
Biconilog	EMCO	3142C	00026873	26-3000 MHz	27 Apr 2020
Horn Antenna	EMCO	3155	6570	1 – 18 GHz	11 Oct 2020
High Pass Filter	K & L	11SH10-1500/T8000	2	Cut off 900 MHz	See Note 1
Log Periodic	ETS-Lindgren	3148	23845	200-2000 MHz	02 Aug 2020
Attenuator	Hewlett Packard	8493C	0465	DC–18 GHz	See Note 1
Note 1: Internal Verification/Calibration Check					

**EXHIBIT 7. MEASUREMENT UNCERTAINTY**

The measurement uncertainties stated were calculated in accordance with the requirements of CISPR 16-4-2 @ IEC:2003 and JCGM 100:2008 (GUM 1995) – Guide to the Expression of Uncertainty in Measurement.

**7.1. LINE CONDUCTED EMISSION MEASUREMENT UNCERTAINTY**

	Line Conducted Emission Measurement Uncertainty (9 kHz – 30 MHz):	Measured	Limit
<b>u<sub>c</sub></b>	<b>Combined standard uncertainty:</b> $u_c(y) = \sqrt{\sum_{i=1}^m u_i^2(y)}$	<b>± 1.44</b>	<b>± 1.8</b>
<b>U</b>	<b>Expanded uncertainty U:</b> $U = 2u_c(y)$	<b>± 2.89</b>	<b>± 3.6</b>

**7.2. RADIATED EMISSION MEASUREMENT UNCERTAINTY**

	Radiated Emission Measurement Uncertainty @ 3m, Horizontal (30-1000 MHz):	Measured (dB)	Limit (dB)
<b>u<sub>c</sub></b>	<b>Combined standard uncertainty:</b> $u_c(y) = \sqrt{\sum_{i=1}^m u_i^2(y)}$	<b>± 2.39</b>	<b>± 2.6</b>
<b>U</b>	<b>Expanded uncertainty U:</b> $U = 2u_c(y)$	<b>± 4.79</b>	<b>± 5.2</b>

	Radiated Emission Measurement Uncertainty @ 3m, Vertical (30-1000 MHz):	Measured (dB)	Limit (dB)
<b>u<sub>c</sub></b>	<b>Combined standard uncertainty:</b> $u_c(y) = \sqrt{\sum_{i=1}^m u_i^2(y)}$	<b>± 2.39</b>	<b>± 2.6</b>
<b>U</b>	<b>Expanded uncertainty U:</b> $U = 2u_c(y)$	<b>± 4.78</b>	<b>± 5.2</b>

	Radiated Emission Measurement Uncertainty @ 3 m, Horizontal & Vertical (1 – 18 GHz):	Measured (dB)	Limit (dB)
<b>u<sub>c</sub></b>	<b>Combined standard uncertainty:</b> $u_c(y) = \sqrt{\sum_{i=1}^m u_i^2(y)}$	<b>± 1.87</b>	<b>Under consideration</b>
<b>U</b>	<b>Expanded uncertainty U:</b> $U = 2u_c(y)$	<b>± 3.75</b>	<b>Under consideration</b>