

NATIONAL CERTIFICATION LABORATORY
8370 Court Avenue, Suite B-1
Ellicott City MD 21043
(410) 461-5548

FCC REPORT OF RADIO INTERFERENCE

for

Microhard Systems Inc
#209 - 12 Manning Close N.E.
Calgary, Alberta Canada

FCC ID: NS998P001X01

July 16, 1998

TABLE OF CONTENTS

Application Form 731
FCC Label Drawing and Location

- 1.0** Introduction
- 1.1** Summary
- 2.0** Description of Equipment Under Test (EUT)
- 3.0** Test Program
- 4.0** Test Configuration
- 5.0** Conducted Emissions Scheme
- 6.0** Radiated Emissions Scheme

TABLES

- Table 1. Support Equipment
- Table 2. Interface Cables
- Table 3. Measurement Equipment

EXHIBITS

- Exhibit 1. EUT Photographs
- Exhibit 2. Schematic Diagram
- Exhibit 3. User Manual
- Exhibit 4. Explanation of 15.247(1)/(1)i

FCC PART 15.247(c) - CONDUCTED SPURIOUS EMISSIONS

Frequency of Carrier = 902.5 MHz

Limit = 20 dBc

Condition: Transmitter is set to a single FM modulated channel.

TEST RESULTS

LIMIT: -20 dB FROM PEAK CARRIER

<u>COMPONENT</u>	<u>FREQUENCY (MHZ)</u>	<u>RESULT (dB FROM PEAK)</u>
HARMONIC	1805.00	- 54.0
HARMONIC	2707.50	- 58.0
HARMONIC	3610.00	- 70.0
HARMONIC	4512.50	- 73.0
HARMONIC	5415.00	- 74.0
HARMONIC	6317.50	- 74.0
HARMONIC	7220.00	- 74.0
HARMONIC	8122.50	- 74.0
HARMONIC	9025.00	- 74.0

FCC PART 15.247(c) - CONDUCTED SPURIOUS EMISSIONS

Frequency of Carrier = 927.8 MHz

Limit = 20 dBc

Condition: Transmitter is set to a single FM modulated channel.

TEST RESULTS

LIMIT: -20 dB FROM PEAK CARRIER

<u>COMPONENT</u>	<u>FREQUENCY (MHZ)</u>	<u>RESULT (dB FROM PEAK)</u>
HARMONIC	1855.60	- 50.0
HARMONIC	2783.40	- 60.0
HARMONIC	3711.20	- 69.0
HARMONIC	4639.00	- 74.0
HARMONIC	5566.80	- 74.0
HARMONIC	6494.60	- 74.0
HARMONIC	7422.40	- 74.0
HARMONIC	8350.20	- 74.0
HARMONIC	9278.00	- 74.0

CONDUCTED RF SPURS AND HARMONICS AT ANTENNA TERMINAL - SET CHANNEL 1

MODULATED

4.0 GHZ SPAN

100 KHZ RES. BW

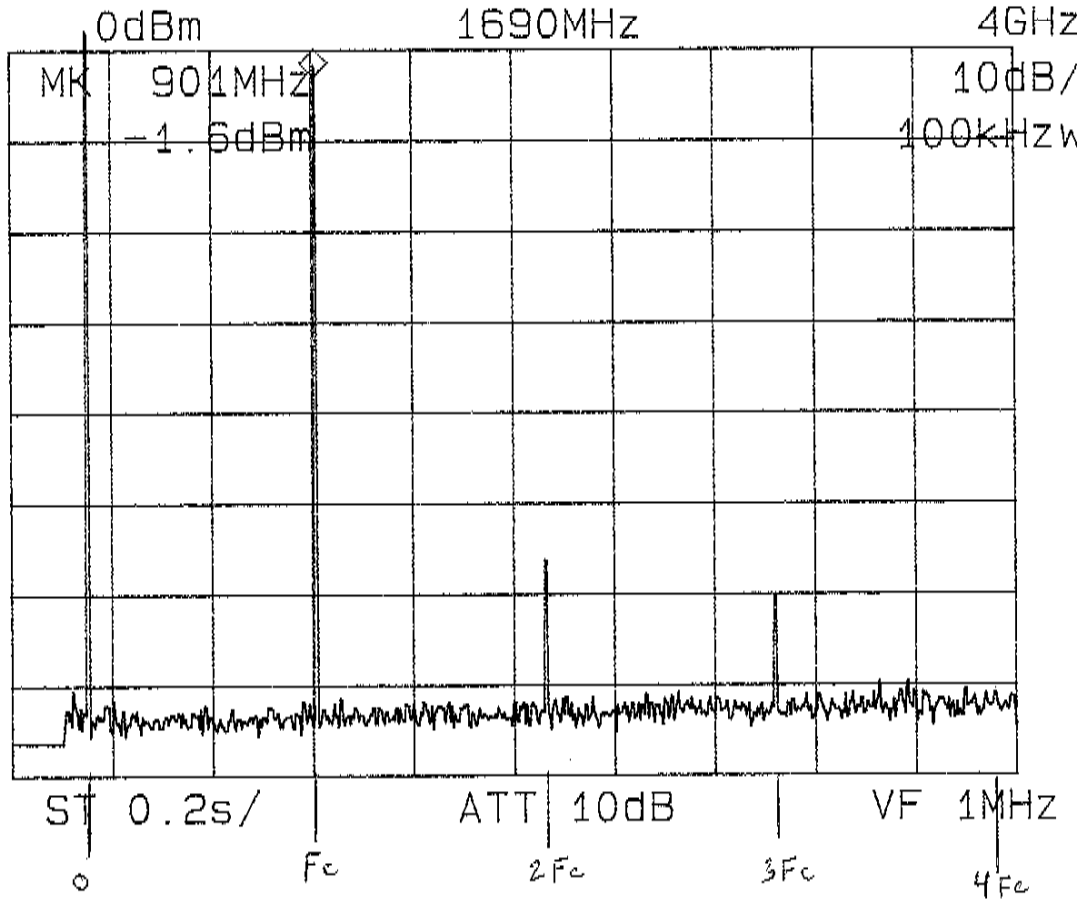

NOTE: 30 dB
XT. ATTN.

CONDUCTED RF SPURS AND HARMONICS AT ANTENNA TERMINAL - SET CHANNEL

MODULATED

4.0 GHZ SPAN

100 KHZ RES. BW

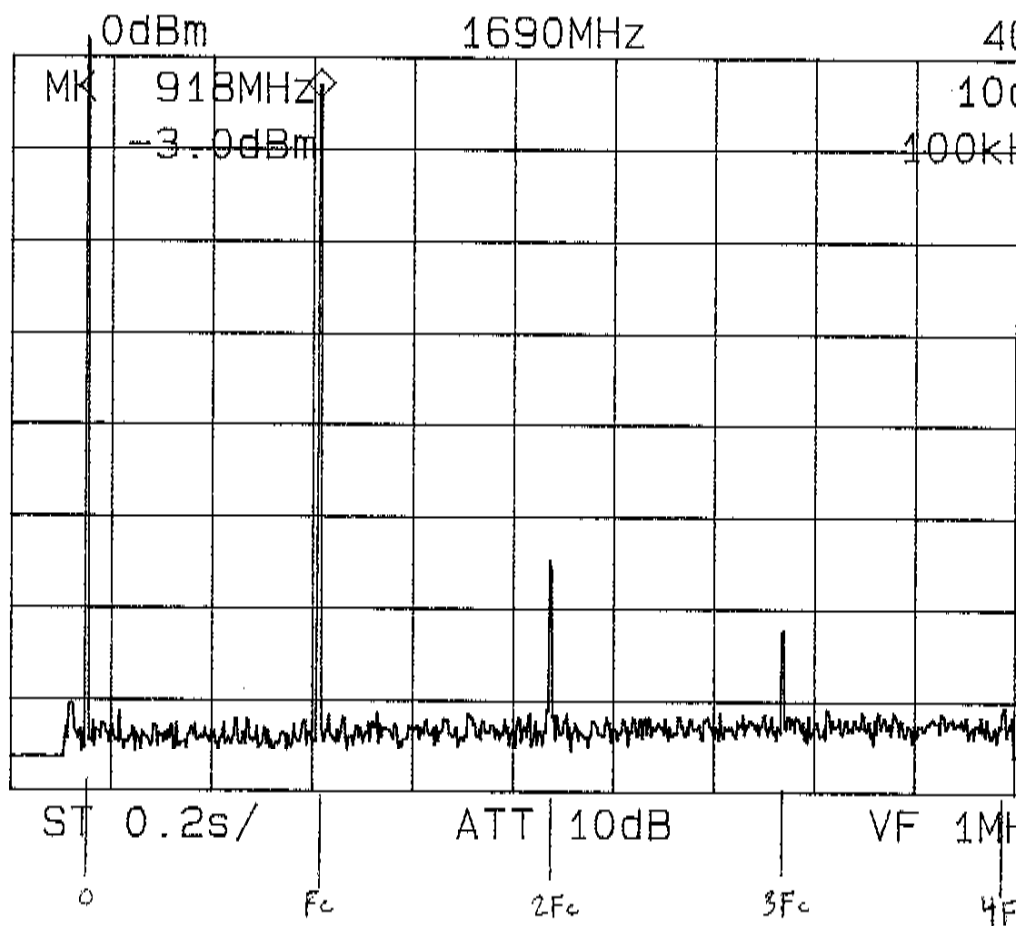

NOTE: 30 dB
EXT. ATTN.

CONDUCTED RF SPURS AND HARMONICS AT ANTENNA TERMINAL - SET CHANNEL

MODULATED

4.0 GHZ SPAN

100 KHZ RES. BW

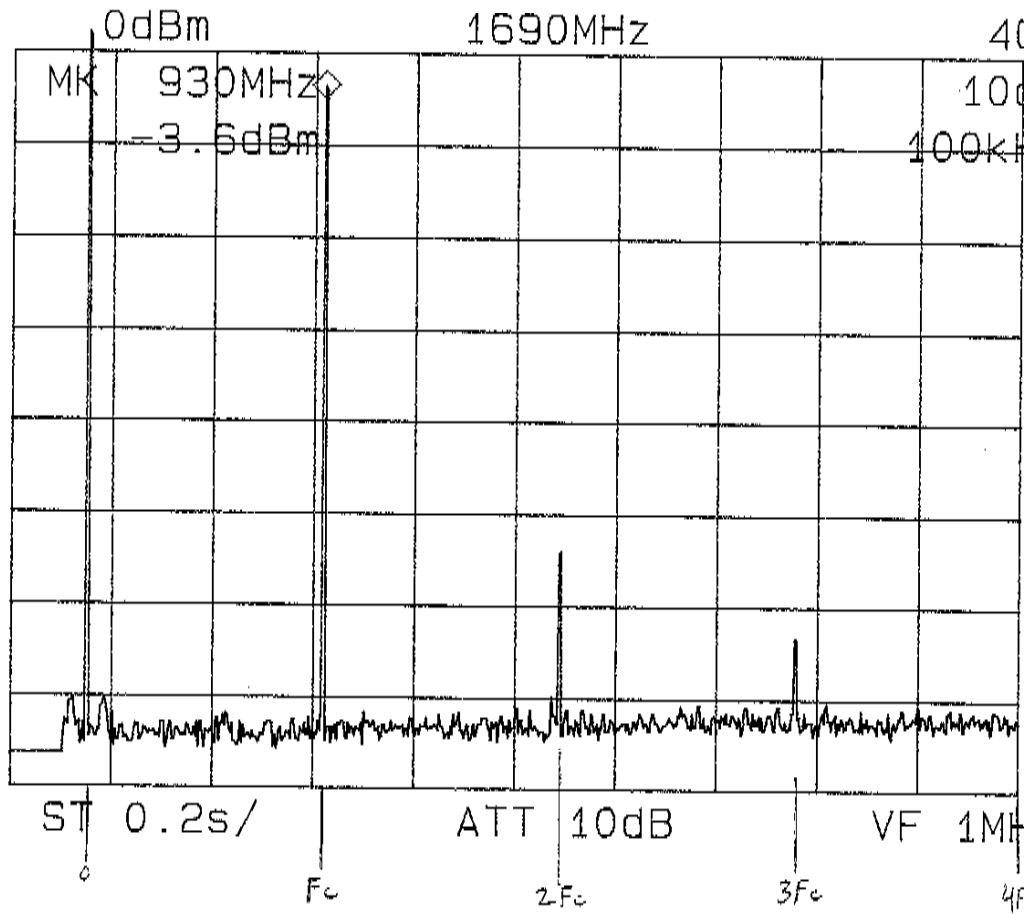

NOTE: 30 dB
EXT. ATTN.

4.0 Test Configuration

RADIATED EMISSIONS

The EUT was set up on the center of the test table, in a manner which follows the general guidelines of ANSI C63.4, Section 6 "General Operating Conditions and Configurations".

This is described below:

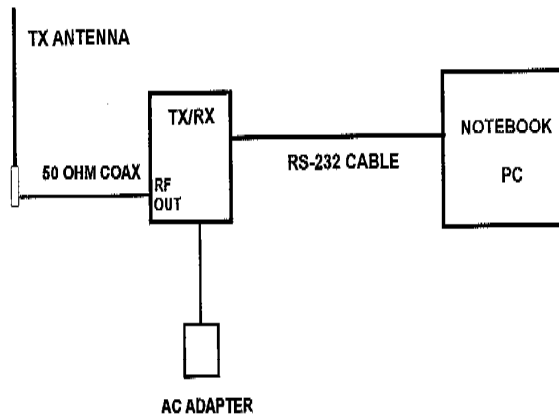

Conducted Emissions Scheme

The EUT is placed on an 80 cm high 1 X 1.5 m non-conductive table. Power to the RF modem is provided through a Solar Corporation 50 Ω /50 μ H Line Impedance Stabilization Network bonded to a 2.2 X 2 meter horizontal ground plane, and a 2.2 X 2 meter vertical ground plane. The LISN has its AC input supplied from a filtered AC power source. A separate LISN provides AC power to the peripheral

equipment. I/O cables are moved about to obtain maximum emissions.

The 50 Ω output of the LISN is connected to the input of the spectrum analyzer and emissions in the frequency range of 450 kHz to 30 MHz are searched. The detector function is set to quasi-peak and the resolution bandwidth is set at 9 kHz, with all post-detector filtering no less than 10 times the resolution bandwidth for final measurements. All emissions within 20 dB of the limit are recorded in the data tables.

FCC CLASS B CONDUCTED EMISSIONS DATA

FCC ID: NS998P001X01

CLIENT: MICROHARD
EUT: MRX-900

FREQ.: 902.5 MHZ

LINE 1 - NEUTRAL

FREQ MHz	VOLTAGE dBuV	QP LEVEL VOLTAGE uV	FCC LIMIT uV	MARGIN dB
0.504	45.6	190.5	250	-2.4
16.6	32.4	41.7	250	-15.6
22.3	40.6	107.2	250	-7.4
27.8	37.6	75.9	250	-10.4

LINE 2 - PHASE

FREQ MHz	VOLTAGE dBuV	QP LEVEL VOLTAGE uV	FCC LIMIT uV	MARGIN dB
0.504	44.8	173.8	250	-3.2
16.6	31.4	37.2	250	-16.6
22.3	42.2	128.8	250	-5.8
27.8	36.4	66.1	250	-11.6

A.C. Line-Conducted Emissions - Line 2

MODULATED

50 MHz SPAN

10 KHZ RES, BW

Conducted L2
70dBuV

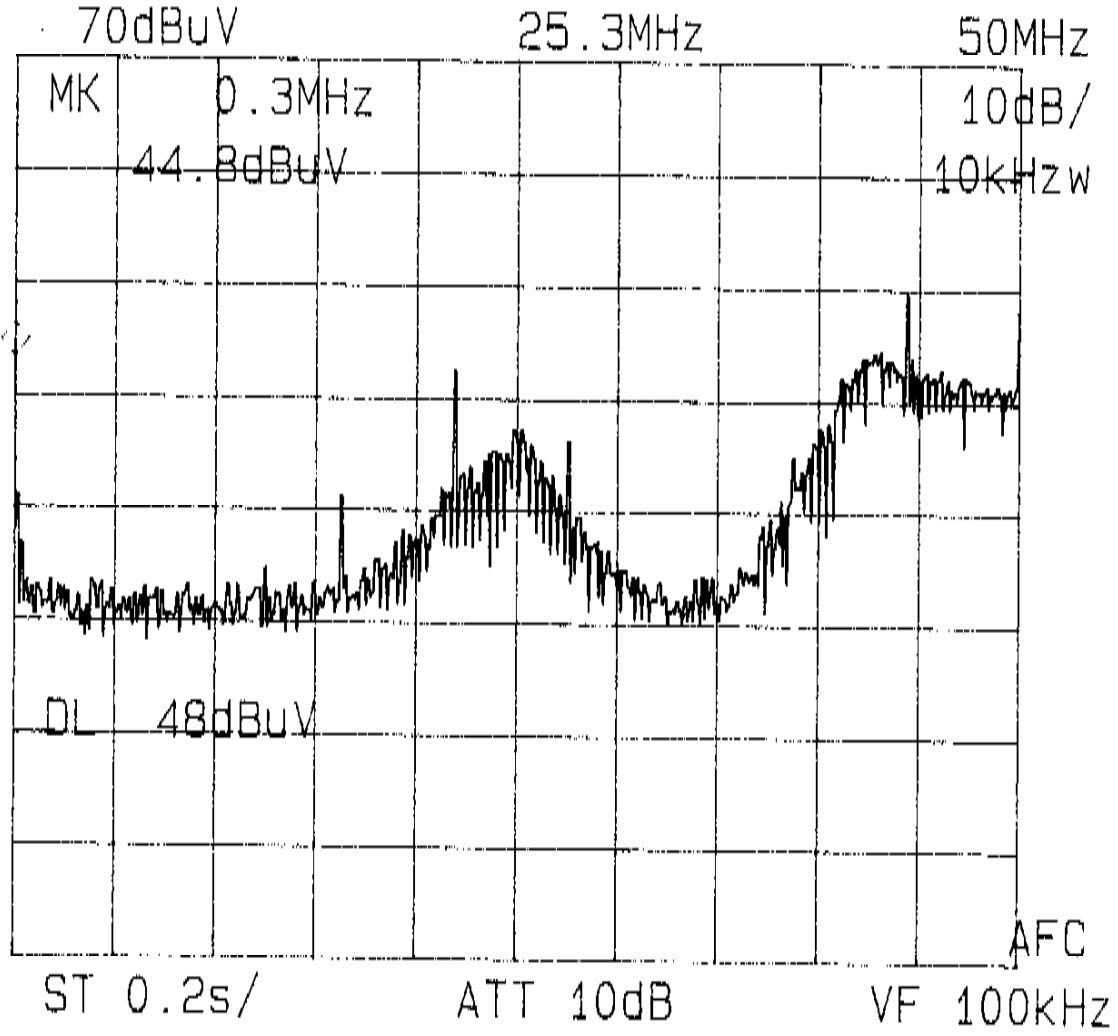

A.C. Line-Conducted Emissions - Line 1

MODULATED

50 MHz SPAN

10 KHZ RES. BW

Conducted - L1
70dBuV

25.3MHz

50MHz

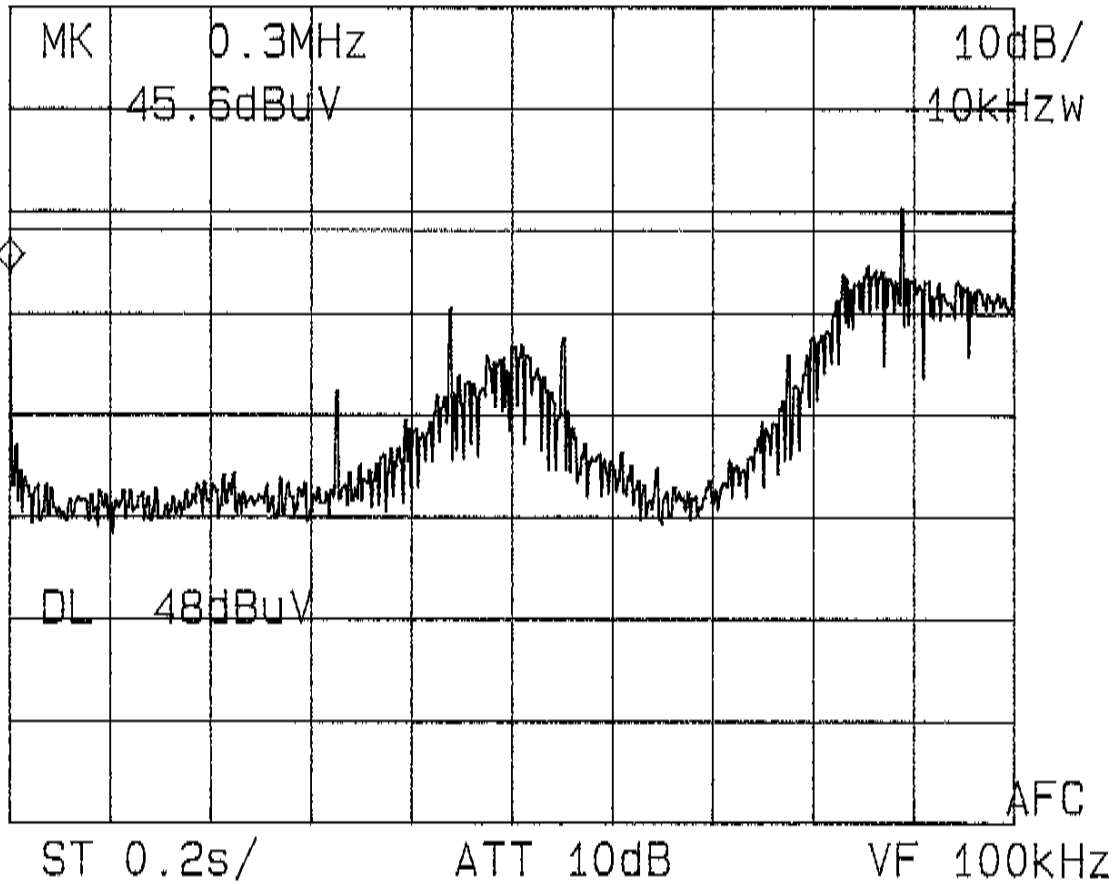

6.0 Radiated Emissions Scheme

The EUT is placed on an 80 cm high 1 X 1.5 meter non-conductive motorized turntable for radiated testing on the 3-meter open area test site. The emissions from the EUT are measured continuously at every azimuth by rotating the turntable. Guided horn and log periodic broadband antennas are mounted on an antenna mast to determine the height of maximum emissions. The height of the antenna is varied between 1 and 4 meters. Both the horizontal and vertical field components are measured.

The RF spectrum is searched from 30 MHz - 9.280 GHz.

The output from the antenna is connected to the input of the preamplifier. The preamp out is connected to the spectrum analyzer. The detector function is set to **Peak**. The resolution bandwidth of the spectrum analyzer is set at 120 kHz, for the frequency range of 30-1000 MHz, and 1 MHz for the range of 1 GHz-9 GHz. A 10 Hz video BW setting is used to average readings above 1 GHz. All emissions within 20 dB of the limit are recorded in the data tables.

To convert the spectrum analyzer reading into a quantified E-field level to allow comparison with the FCC limits, it is necessary to account for various calibration factors. These factors include cable loss (CL) and antenna factors (AF). The AF/CL in dB/m is algebraically added to the Spectrum Analyzer Voltage in dB μ V to obtain the Radiated Electric Field in dB μ V/m. This level is then compared with the FCC limit.

Example:

Spectrum Analyzer Volt: VdB μ V

Composite Factor: AF/CLdB/m

Electric Field: EdB μ V/m = VdB μ V + AF/CLdB/m

Linear Conversion: EuV/m = Antilog (EdB μ V/m/20)

FCC 15.209 RADIATED EMISSIONS DATA

FCC ID: NS998P001X01

CLIENT: MICROHARD
 EUT: MRX-900

CARRIER: 902.5 MHz @ 1000 mW
 ANTENNA: 5 DB OMNI

FREQ MHz	POL. H/V	AVRG				AVRG		
		SPEC A dBuV	AF/C dB/m	PREAM GAIN	E-FIELD dBuV/m	E-FIELD uV/m	LIMIT uV/m	MARG dB
2707.50	V	40.0	35.0	-25	50.0	316.2	500.0	-4.0
3610.00	H	35.0	36.0	-25	46.0	199.5	500.0	-8.0
4512.50	V	33.0	39.0	-25	47.0	223.9	500.0	-7.0
5415.00	H	32.0	37.0	-25	44.0	158.5	500.0	-10.0
8122.50	V	29.0	38.0	-25	42.0	125.9	500.0	-12.0
9025.00	V	29.0	39.0	-25	43.0	141.3	500.0	-11.0

TEST ENGINEER

SD
 _____ DATE 7/2/11
 STEVE DAYHOFF

FCC 15.209 RADIATED EMISSIONS DATA

FCC ID: NS998P001X01

CLIENT: MICROHARD

EUT: MRX-900

CARRIER: 915 MHZ @ 1000 mW

ANTENNA: 5 DB OMNI

FREQ MHz	POL H/V	AVRG			E-FIELD dBuV/m	E-FIELD uV/m	AVRG	
		SPL/C A dBuV	AF/C dB/m	PREAM GAIN			LIMIT uV/m	MARG dB
2745.00	V	38.0	35.0	-25	48.0	251.2	500.0	-6.0
3660.00	H	34.0	36.0	-25	45.0	177.8	500.0	-9.0
4575.00	V	32.0	39.0	-25	46.0	199.5	500.0	-8.0
7320.00	H	34.0	37.0	-25	46.0	199.5	500.0	-8.0
8235.00	V	32.0	38.0	-25	45.0	177.8	500.0	-9.0
9150.00	V	29.0	39.0	-25	43.0	141.3	500.0	-11.0

TEST ENGINEER

SD DATE *11/1/08*
STEVE DAYHOFF

FCC 15.209 RADIATED EMISSIONS DATA

FCC ID: NS998P001X01

CLIENT: MICROTIARD
EUT: MRX-900

CARRIER: 927.8 MHZ @ 1000 mW
ANTENNA: 5 DB OMNI

FREQ MHz	POL H/V	AVRG			E-FIELD dBuV/m	E-FIELD uV/m	AVRG	
		SPEC A dBuV	AF/C dB/m	PREAM GAIN			LIMIT uV/m	MARG dB
2783.40	V	41.0	35.0	-25	51.0	354.8	500.0	-3.0
3711.20	H	37.0	36.0	-25	48.0	251.2	500.0	-6.0
4639.00	V	34.0	39.0	-25	48.0	251.2	500.0	-6.0
7422.40	H	31.0	37.0	-25	43.0	141.3	500.0	-11.0
8350.20	V	28.0	38.0	-25	41.0	112.2	500.0	-13.0

TEST ENGINEER

 SD DATE *7/16/05*
STEVE DAYHOFF

FCC 15.209 RADIATED EMISSIONS DATA

FCC ID: NS998P001X01

CLIENT: MICROHARD
EUT: MRX-900

CARRIER: 902.5 MHz @ 100 mW
ANTENNA: 14 DB YAGI

FREQ MHz	POL H/V	AVRG			E-FIELD dBuV/m	E-FIELD uV/m	AVRG	
		SPEC A dBuV	AF/C dB/m	PREAM GAIN			LIMIT uV/m	MRG dB
2707.50	V	41.0	35.0	-25	51.0	354.8	500.0	-3.0
3610.00	H	37.0	36.0	-25	48.0	251.2	500.0	-6.0
4512.50	H	36.0	39.0	-25	50.0	316.2	500.0	-4.0
5415.00	H	31.0	37.0	-25	43.0	141.3	500.0	-11.0
8122.50	H	31.0	38.0	-25	44.0	158.5	500.0	-10.0
9025.00	V	27.0	39.0	-25	41.0	112.2	500.0	-13.0

TEST ENGINEER

 DATE 7/26/14
STEVE DAYHOFF

FCC 15.209 RADIATED EMISSIONS DATA



FCC ID: NS998P001X01

CLIENT: MICROHARD
 EUI: MRX-900

CARRIER: 915 MHz @ 100 mW
 ANTENNA: 14 DB YAGI

FREQ MHz	POL H/V	AVRG			E-FIELD dBuV/m	E-FIELD uV/m	AVRG	
		SPEC A dBuV	AF/C dB/m	PREAM GAIN			LIMIT uV/m	MRC dB
2745.00	V	39.0	35.0	-25	49.0	281.8	500.0	-5.0
3660.00	H	36.0	36.0	-25	47.0	223.9	500.0	-7.0
4575.00	H	36.0	39.0	-25	50.0	316.2	500.0	-4.0
7320.00	H	31.0	37.0	-25	43.0	141.3	500.0	-11.0
8235.00	H	32.0	38.0	-25	45.0	177.8	500.0	-9.0
9150.00	V	29.0	39.0	-25	43.0	141.3	500.0	-11.0

TEST ENGINEER

 DATE: 
 STEVE DAYHOFF

FCC 15.209 RADIATED EMISSIONS DATA

FCC ID: NS998P001X01

CLIENT: MICROHARD

EUT: MRX-900

CARRIER: 927.8 MHz @ 100 mW

ANTENNA: 14 DB YAGI

FREQ MHz	POL H/V	AVRG			E-FIELD dBuV/m	AVRG		
		SPEC A dBuV	AI/C dB/m	PREAM GAIN		E-FIELD uV/m	LIMIT uV/m	MARG dB
2783.40	V	38.0	35.0	-25	48.0	251.2	500.0	-6.0
3711.20	H	36.0	36.0	-25	47.0	223.9	500.0	-7.0
4639.00	H	30.0	39.0	-25	44.0	158.5	500.0	-10.0
7422.40	H	30.0	37.0	-25	42.0	125.9	500.0	-12.0
8350.20	V	29.0	38.0	-25	42.0	125.9	500.0	-12.0

TEST ENGINEER

(Signature)

DATE *4/2/08*

STEVE DAYHOFF

Table 1
Support Equipment

14 dB Yagi Antenna - Sinclabs - SUY-90213

12 dB Yagi Antenna - Sinclabs - SUY-90211

8 dB Yagi Antenna - Sinclabs - SUY-90207

2.5 dB Omni Antenna - 900 MHz Rubber Ducky

5 dB Omni Antenna - Sinclabs

Host PC - Toshiba 740C Pentium Notebook

Table 2

Interface Cables Used

1. A 1.2 meter RS-232 serial shielded cable is used to connect the EUT to the Host computer.
2. 2 feet of low-loss coaxial cable used to connect the EUT to the TX antenna.

Table 3

Measurement Equipment Used

The following equipment is used to perform measurements:

HP 435A RF Peak Power Meter	- Serial No. 1362016
EMCO Model 3110 Biconical Antenna	- Serial No. 1619
Antenna Research MWH-1825B Horn Antenna	- Serial No. 1005
EMCO Model 3115 Ridged Horn Antenna	- Serial No. 3007
HP 8348A Preamplifier	- Serial No. 197-2564A
Solar 8012-50-R-24-BNC LISN	- Serial No. 924867
Bird 8306-300-N 30dB Attenuator	- S/N: 29198391515
Tektronix R3272 Spectrum Analyzer	- Serial No. 6-95-1124
4 Meter Antenna Mast	
Motorized Turntable	
Heliac FSJ1-50A 1/4" Superflex Coax Cable (12 Ft.)	

EXHIBIT 1

EUT PHOTOGRAPHS

See Confidential Sealed Envelope

EXHIBIT 2

SCHEMATIC DIAGRAM

See Confidential Sealed Envelope

EXHIBIT 3

USER MANUAL

EXHIBIT 4

EXPLANATION OF SECTION 15.247(1)/(1)i

The MRX-900 is a wireless spread spectrum modem which uses frequency hopping complying with section 15.247. The receiver and transmitter bandwidths are fixed at 350kHz.

Each modem can be configured to use one of 20 hopping patterns. The hopping patterns are stored in non-volatile memory, and were generated with a piece of MATLAB code which includes a random number generator but also ensures equal channel usage within patterns. Channel frequencies start at 902.4 MHz and increment by 400 kHz up to 927.6 MHz, for a total of 64 different channels. Each hopping pattern consists of 128 values, such that each channel is visited twice. The code used to generate the patterns, along with a sample hopping pattern are provided below:

```
% This file generates pseudorandom hopping patterns
% Then it writes them to an output file
%
%   Date: Dec. 12, 1997
%   Author: Hany Shenouda
%   Microhard Systems Inc.

%   VARIABLES
%   *****
PatMax = 128;           %Size of Pattern
NumPat = 20;           %Number of Hopping Patterns
ChMin = 1;             %Minimum Channel
ChMax = 64;           %Maximum Channel
ChMat = zeros(PatMax,NumPat);

for j=1:PatMax
for j=1:NumPat
repeat = 1;

while(repeat);
repeat = 0;
usage = 0;
ChNum = getchn(ChMin,ChMax);
% for jj = 1:j
% if ChNum :- ChMat(i,jj)
%     repeat = 1;
% end
% end
for kk = 1:i
m == ChMat(kk,j);
usage = usage + 1;
end
if usage >= 2
```



```

        end
        end
        end
        ChNum
        ChMat(i,j)=ChNum;

        end
        end

%      WRITE S Parameter File
%      *****
%      save hoppat.dat ChMat -ascii -tabs
%      fid = fopen(filename,'w');
%      fwrite(fid,ChMat,'integer*2',1);
%      fclose(fid);

fid=fopen('Hoppat128.dat','w');
for i = 1:NumPat
fprintf(fid,'\r\n\r\nTable%02i\r\n',i);
fprintf(fid,'\tdb\t%02i,%02i,%02i,%02i,%02i,%02i,%02i,%02i\r\n',ChMat(1:PatMax,i));
end
fclose(fid)

function [ChNum] = getchn(ChMin,ChMax);
% This function assigns a random channel number

ChNum = 0;
while(ChNum<ChMin | ChNum > ChMax)
    ChNum = round(rand*100);
end
return;

```

Table05

```

db 47,04,16,04,16,13,63,06
db 21,01,09,13,07,55,23,12
db 51,26,64,39,63,40,14,54
db 12,53,07,15,37,26,64,22
db 09,36,53,51,35,62,03,06
db 24,61,43,25,56,24,38,46
db 40,32,47,17,61,59,33,52
db 25,17,38,48,15,10,19,42
db 54,01,46,52,44,55,05,57
db 35,57,41,45,58,19,20,42
db 44,36,41,62,50,34,21,43
db 50,30,45,29,18,59,08,20
db 28,11,56,14,30,32,18,02
db 31,49,02,29,37,60,23,27
db 10,08,39,28,49,58,22,11
db 48,34,33,60,27,05,31,03

```

Each modem can be configured as either a Master or a Slave. A Master transmits for a fixed time interval of 100 ms before hopping to the next channel in the hopping table. Once configured, a Master never deviates from the hopping pattern or hop duration. It will continually cycle through the hopping pattern indefinitely at the fixed time interval of 100 ms. Slaves acquire synchronization by listening on a channel which occasionally changes until synchronizing information has been received from the Master. At which point, the Slave begins to hop according to the same table as the Master, and at the same fixed time interval. If a packet of data needs to be repeated, it will be repeated after the next hop. Multiple packets of data will be sent on one hop as long as there is enough time in the fixed time interval to do so.

The Master transmits a control packet on every hop, even if there is no data to be transmitted. When the Master does have data to transmit, this transmission will commence at the position in the hop table that the Master happens to be at, which may be any of the 64 channels. This ensures that the transmission does not always start on the same channel.

To ensure that the transmitter cannot coordinate its hopping sequence with the hopping sequence of other transmitters, each transmitter has no ability to deviate in hop time or hopping pattern position once normal operation commences.

