

ENGINEERING TEST REPORT

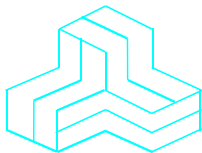

900 MHz OEM Frequency Hopping / DTS Module

Model: n920BT

FCC ID: NS908P25

Applicant:

Microhard Systems Inc.
150 Country Hills Landing NW
Calgary, Alberta
Canada T3K 5P3

In Accordance With

**Federal Communications Commission (FCC)
Part 15, Subpart C, Section 15.247 Frequency Hopping Spread Spectrum (FHSS) / Digital
Modulation Systems (DTS) Operating in 902 - 928 MHz Band**

UltraTech's File No.: MCRS-066F15C247

This Test report is Issued under the Authority of
Tri M. Luu
Vice President of Engineering
UltraTech Group of Labs

Date: September 11, 2013

Report Prepared by: Dan Huynh

Tested by: Mr. Hung Trinh

Issued Date: September 11, 2013

Test Dates: June 28, August 8, 2013

- *The results in this Test Report apply only to the sample(s) tested, and the sample tested is randomly selected.*
- *This report must not be used by the client to claim product endorsement by NVLAP or any agency of the US Government.*

UltraTech

3000 Bristol Circle, Oakville, Ontario, Canada, L6H 6G4
Tel.: (905) 829-1570 Fax.: (905) 829-8050
Website: www.ultratech-labs.com, Email: vic@ultratech-labs.com, Email: tri@ultratech-labs.com

FCC

91038



1309



46390-2049



NVLAP LAB CODE 200093-0



SL2-IN-E-1119R



Korea KCC-RRL
CA2049

TABLE OF CONTENTS

EXHIBIT 1. INTRODUCTION..... 1

1.1. SCOPE 1

1.2. RELATED SUBMITTAL(S)/GRANT(S) 1

1.3. NORMATIVE REFERENCES 1

EXHIBIT 2. PERFORMANCE ASSESSMENT..... 2

2.1. CLIENT INFORMATION 2

2.2. EQUIPMENT UNDER TEST (EUT) INFORMATION 2

2.3. EUT’S TECHNICAL SPECIFICATIONS..... 3

2.4. ASSOCIATED ANTENNA DESCRIPTIONS 4

2.5. LIST OF EUT’S PORTS..... 4

2.6. ANCILLARY EQUIPMENT 4

EXHIBIT 3. EUT OPERATING CONDITIONS AND CONFIGURATIONS DURING TESTS..... 5

3.1. CLIMATE TEST CONDITIONS 5

3.2. OPERATIONAL TEST CONDITIONS & ARRANGEMENT FOR TESTS..... 5

EXHIBIT 4. SUMMARY OF TEST RESULTS 6

4.1. LOCATION OF TESTS 6

4.2. APPLICABILITY & SUMMARY OF EMC EMISSION TEST RESULTS 6

4.3. MODIFICATIONS INCORPORATED IN THE EUT FOR COMPLIANCE PURPOSES..... 6

EXHIBIT 5. TEST DATA 7

5.1. POWER LINE CONDUCTED EMISSIONS [§15.207(a)]..... 7

5.2. PEAK CONDUCTED OUTPUT POWER [§§ 15.247(b)(2) & (3), FHSS and DTS] 12

5.3. TRANSMITTER SPURIOUS RADIATED EMISSIONS AT 3 METERS [§§ 15.247(d), 15.209 & 15.205] 14

5.4. RF EXPOSURE REQUIRMENTS [§§ 15.247(i), 1.1310 & 2.1091]..... 23

EXHIBIT 6. TEST EQUIPMENT LIST 25

EXHIBIT 7. MEASUREMENT UNCERTAINTY 26

7.1. LINE CONDUCTED EMISSION MEASUREMENT UNCERTAINTY 26

7.2. RADIATED EMISSION MEASUREMENT UNCERTAINTY 26

EXHIBIT 1. INTRODUCTION

1.1. SCOPE

Reference:	FCC Part 15, Subpart C, Section 15.247
Title:	Code of Federal Regulations (CFR), Title 47 – Telecommunication, Part 15 – Radio Frequency Devices
Purpose of Test:	Class II Permissive Change
Test Procedures:	<ul style="list-style-type: none"> ▪ ANSI C63.4 ▪ ANSI C63.10
Environmental Classification:	<input checked="" type="checkbox"/> Commercial, industrial or business environment <input checked="" type="checkbox"/> Residential environment

1.2. RELATED SUBMITTAL(S)/GRANT(S)

None.

1.3. NORMATIVE REFERENCES

Publication	Year	Title
47 CFR Parts 0-19	2013	Code of Federal Regulations (CFR), Title 47 – Telecommunication
ANSI C63.4	2009	American National Standard for Methods of Measurement of Radio-Noise Emissions from Low-Voltage Electrical and Electronic Equipment in the Range of 9 KHz to 40 GHz
ANSI C63.10	2009	American National Standard for Testing Unlicensed Wireless Devices
CISPR 22 & EN 55022	2008-09, Edition 6.0 2006	Information Technology Equipment - Radio Disturbance Characteristics - Limits and Methods of Measurement
CISPR 16-1-1 +A1 +A2	2006 2006 2007	Specification for radio disturbance and immunity measuring apparatus and methods. Part 1-1: Measuring Apparatus
FCC Public Notice DA 00-705	2000	Filing and Measurement Guidelines for Frequency Hopping Spread Spectrum Systems
FCC Public Notice DA 00-1407	2000	Part 15 Unlicensed Modular Transmitter Approval
FCC ET Docket No. 99-231	2002	Amendment to FCC Part 15 of the Commission's Rules Regarding to Spread Spectrum Devices
D01 DTS Meas Guidance v03r01	2013	Guidance for Performing Compliance Measurements on Digital Transmission Systems (DTS) Operating Under §15.247

ULTRATECH GROUP OF LABS

3000 Bristol Circle, Oakville, Ontario, Canada L6H 6G4
 Tel. #: 905-829-1570, Fax. #: 905-829-8050, Email: vic@ultratech-labs.com, Website: <http://www.ultratech-labs.com>

File #: MCRS-066F15C247
 September 11, 2013

All test results contained in this engineering test report are traceable to National Institute of Standards and Technology (NIST)

EXHIBIT 2. PERFORMANCE ASSESSMENT

2.1. CLIENT INFORMATION

APPLICANT	
Name:	Microhard Systems Inc.
Address:	150 Country Hills Landing NW Calgary, Alberta Canada T3K 5P3
Contact Person:	Mr. Hany Shenouda Phone #: 403 248-0028 Fax #: 403 248 2762 Email Address: shenouda@microhardcorp.com

MANUFACTURER	
Name:	Microhard Systems Inc.
Address:	150 Country Hills Landing NW Calgary, Alberta Canada T3K 5P3
Contact Person:	Mr. Hany Shenouda Phone #: 403 248-0028 Fax #: 403 248-2762 Email Address: shenouda@microhardcorp.com

2.2. EQUIPMENT UNDER TEST (EUT) INFORMATION

The following information (with the exception of the Date of Receipt) has been supplied by the applicant.

Brand Name:	Microhard Systems Inc.
Product Name:	900 MHz OEM Frequency Hopping / DTS Module
Model Name or Number:	n920BT
Serial Number:	Test Sample
Type of Equipment:	Spread Spectrum Transmitter / Digital Transmission System
Input Power Supply Type:	External Regulated DC Sources
Primary User Functions of EUT:	Spread Spectrum OEM Transceiver.

ULTRATECH GROUP OF LABS

3000 Bristol Circle, Oakville, Ontario, Canada L6H 6G4
Tel. #: 905-829-1570, Fax. #: 905-829-8050, Email: vic@ultratech-labs.com, Website: <http://www.ultratech-labs.com>

File #: MCRS-066F15C247
September 11, 2013

All test results contained in this engineering test report are traceable to National Institute of Standards and Technology (NIST)

2.3. EUT’S TECHNICAL SPECIFICATIONS

TRANSMITTER	
Equipment Type:	<ul style="list-style-type: none"> ▪ Mobile ▪ Base Station (fixed use)
Intended Operating Environment:	<ul style="list-style-type: none"> ▪ Commercial, industrial or business environment ▪ Residential environment
Power Supply Requirement:	3.3 VDC
RF Output Power Rating:	0.001 to 1 W
Operating Frequency Range:	FHSS: 902.4 - 927.6 MHz DTS: 903.75 - 926.25 MHz 904 - 926 MHz 905 - 925 MHz 907 - 923 MHz
RF Output Impedance:	50 Ω
*Channel Spacing:	400kHz Frequency hopping / DTS mode different Channelization
Duty Cycle:	Continuous
20 dB Bandwidth (FHSS):	400.80 kHz
6 dB Bandwidth (DTS):	1.03 MHz (903.75 - 926.25 MHz) 1.28 MHz (904 - 926 MHz) 1.73 MHz (905 - 925 MHz) 2.68 MHz (907 - 923 MHz)
Modulation Type:	2-level FSK
Emission Designation:	401KF1D (FHSS, 902.4 – 927.6 MHz) 1M03F1D (DTS, 903.75 - 926.25 MHz) 1M28F1D (DTS, 904 – 926 MHz) 1M73F1D (DTS, 905 – 925 MHz) 2M68F1D (DTS, 907 – 923 MHz)
Power Spectral Density in 3kHz Band:	4.66 dBm Max.
Antenna Connector Type:	MMCX

* See original filing Operational Description exhibit for details.

2.4. ASSOCIATED ANTENNA DESCRIPTIONS

There are six antenna families:

1. Quarter Wave
2. Rubber Ducky
3. Transit
4. Omni Directional
5. Patch
6. Yagi

The highest gain antenna from each of the above antenna families were selected for testing to represents the worst-case. Refer to antennas list exhibit for detailed specifications.

2.5. LIST OF EUT’S PORTS

Port Number	EUT’s Port Description	Number of Identical Ports	Connector Type	Cable Type (Shielded/Non-shielded)
1	RF IN/OUT Port	1	MMCX	Shielded coaxial cable with unique coupling connectors
2	DC Supply & I/O Port	1	Pin Header	No cable, direct connection

2.6. ANCILLARY EQUIPMENT

The EUT was tested while connected to the following representative configuration of ancillary equipment necessary to exercise the ports during tests:

Ancillary Equipment # 1	
Description:	Test Jig
Brand name:	Microhard Systems Inc.
Model Name or Number:	Test sample
Connected to EUT’s Port:	I/O Port

Ancillary Equipment # 2	
Description:	Switching AC/DC Power Adaptor
Brand name:	BI
Model Name or Number:	BI30-120200-AdU
Connected to EUT’s Port:	Test Jig of the EUT

EXHIBIT 3. EUT OPERATING CONDITIONS AND CONFIGURATIONS DURING TESTS

3.1. CLIMATE TEST CONDITIONS

The climate conditions of the test environment are as follows:

Temperature:	21°C
Humidity:	51%
Pressure:	102 kPa
Power Input Source:	3.3 VDC

3.2. OPERATIONAL TEST CONDITIONS & ARRANGEMENT FOR TESTS

Operating Modes:	<ul style="list-style-type: none"> ▪ Each of lowest, middle and highest channel frequencies transmits continuously for emissions measurements. ▪ The EUT operates in normal Frequency Hopping mode for occupancy duration, and frequency separation.
Special Test Software & Hardware:	Special software provided by the applicant was installed to allow the EUT to operate in hopping mode or at each channel frequency continuously. For example, the transmitter will be operated at each of lowest, middle and highest frequencies individually continuously during testing.
Transmitter Test Antenna:	The EUT is tested with the antenna fitted in a manner typical of normal intended use as a non-integral antenna equipment as described with the test results.

Transmitter Test Signals	
Frequency Band(s):	FHSS: 902.4 – 927.6 MHz DTS: 903.75 - 926.25 MHz, 904 -926 MHz 905 - 925 MHz, 907 - 923 MHz
Frequency(ies) Tested: (Near lowest, near middle & near highest frequencies in the frequency range of operation.)	FHSS: 902.4, 915 and 927.6 MHz DTS: 903.75, 915 and 926.25 MHz 904, 915 and 926 MHz 905, 915 and 925 MHz 907, 915 and 923 MHz
RF Power Output: (measured maximum output power at antenna terminals)	1 Watt (conducted)
*Normal Test Modulation:	FHSS: 2-level FSK at data rate 5 DTS: 2-level FSK at data rate 8, 9, 10 and 11
Modulating Signal Source:	Internal

*See Operational Description exhibit supplied by the manufacturer for details of the data rates for FHSS/DTS.

EXHIBIT 4. SUMMARY OF TEST RESULTS

4.1. LOCATION OF TESTS

All of the measurements described in this report were performed at Ultratech Group of Labs located in the city of Oakville, Province of Ontario, Canada.

- AC Power Line Conducted Emissions were performed in UltraTech's shielded room, 24'(L) by 16'(W) by 8'(H).
- Radiated Emissions were performed at the Ultratech's 3-10 TDK Semi-Anechoic Chamber situated in the Town of Oakville, province of Ontario. This test site been calibrated in accordance with ANSI C63.4, and found to be in compliance with the requirements of Sec. 2.948 of the FCC Rules. The descriptions and site measurement data of the Oakville 3-10 TDK Semi-Anechoic Chamber has been filed with FCC office (FCC File No.: 91038) and Industry Canada office (Industry Canada File No.: 2049A-3). Expiry Date: 2014-04-04.

4.2. APPLICABILITY & SUMMARY OF EMC EMISSION TEST RESULTS

FCC Section(s)	Test Requirements	Compliance (Yes/No)
15.203	Antenna requirements	Yes*
15.207(a)	Power Line Conducted Emissions	Yes
15.247(a)(1)	Provisions for Frequency Hopping Systems	N/A
15.247(a)(2)	6 dB Bandwidth	N/A
15.247(b)(2)	Peak Conducted Output Power - FHSS	Yes
15.247(b)(3)	Peak Conducted Output Power - DTS	Yes
15.247(d)	Band-Edge and RF Conducted Spurious Emissions at the Transmitter Antenna Terminal	Yes
15.247(d), 15.209 & 15.205	Transmitter Spurious Radiated Emissions	Yes
15.247(e), (f)	Power Spectral Density	N/A
15.247(i), 1.1307, 1.1310, 2.1091	RF Exposure	Yes

* The EUT complies with the requirement; it employs a unique (non-standard) antenna.

4.3. MODIFICATIONS INCORPORATED IN THE EUT FOR COMPLIANCE PURPOSES

None.

ULTRATECH GROUP OF LABS

3000 Bristol Circle, Oakville, Ontario, Canada L6H 6G4
Tel. #: 905-829-1570, Fax. #: 905-829-8050, Email: vic@ultratech-labs.com, Website: <http://www.ultratech-labs.com>

File #: MCRS-066F15C247
September 11, 2013

All test results contained in this engineering test report are traceable to National Institute of Standards and Technology (NIST)

EXHIBIT 5. TEST DATA

5.1. POWER LINE CONDUCTED EMISSIONS [§15.207(a)]

5.1.1. Limit(s)

The equipment shall meet the limits of the following table:

Frequency of emission (MHz)	Conducted Limits (dBµV)	
	Quasi-peak	Average
0.15–0.5	66 to 56*	56 to 46*
0.5–5	56	46
5–30	60	50

*Decreases linearly with the logarithm of the frequency

5.1.2. Method of Measurements

ANSI C63.4-2009

5.1.3. Test Arrangement

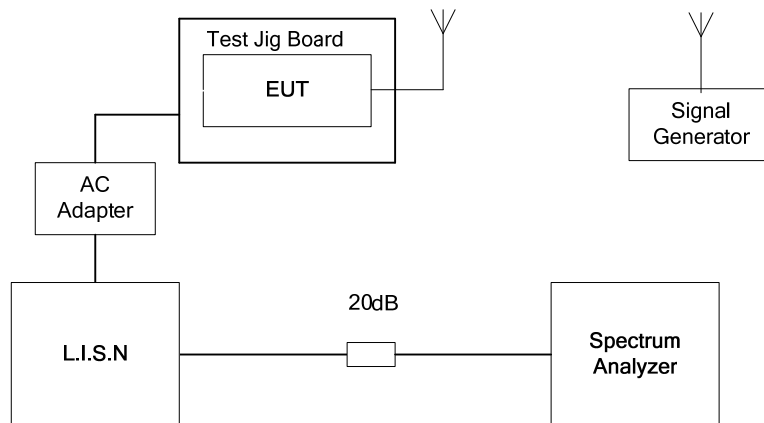

5.1.4. Test Data

Plot 5.1.4.1. Power Line Conducted Emissions; Line Voltage: 120 VAC; Line Tested: Hot; Tx Mode

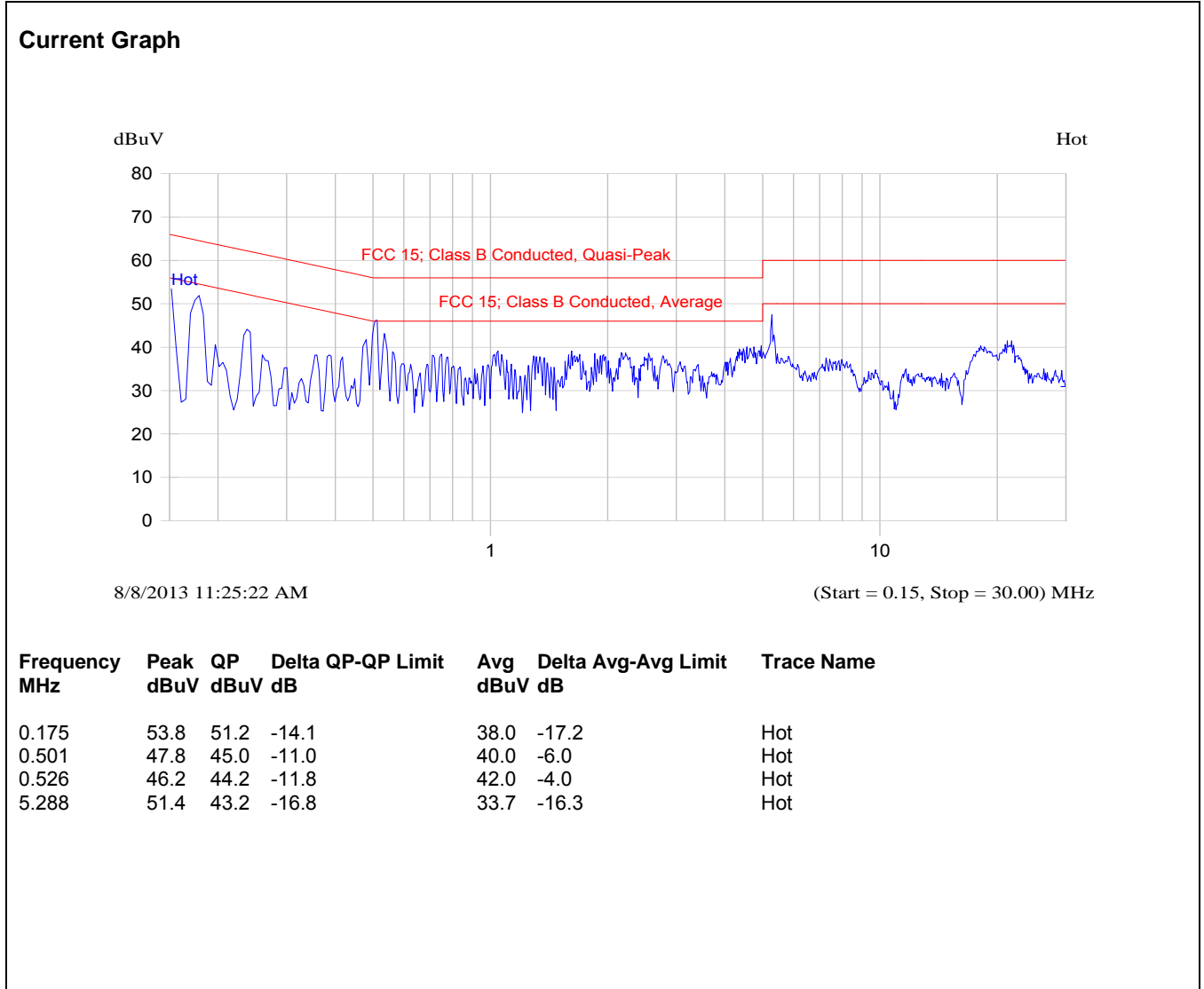

Plot 5.1.4.2. Power Line Conducted Emissions; Line Voltage: 120 VAC; Line Tested: Neutral; Tx Mode

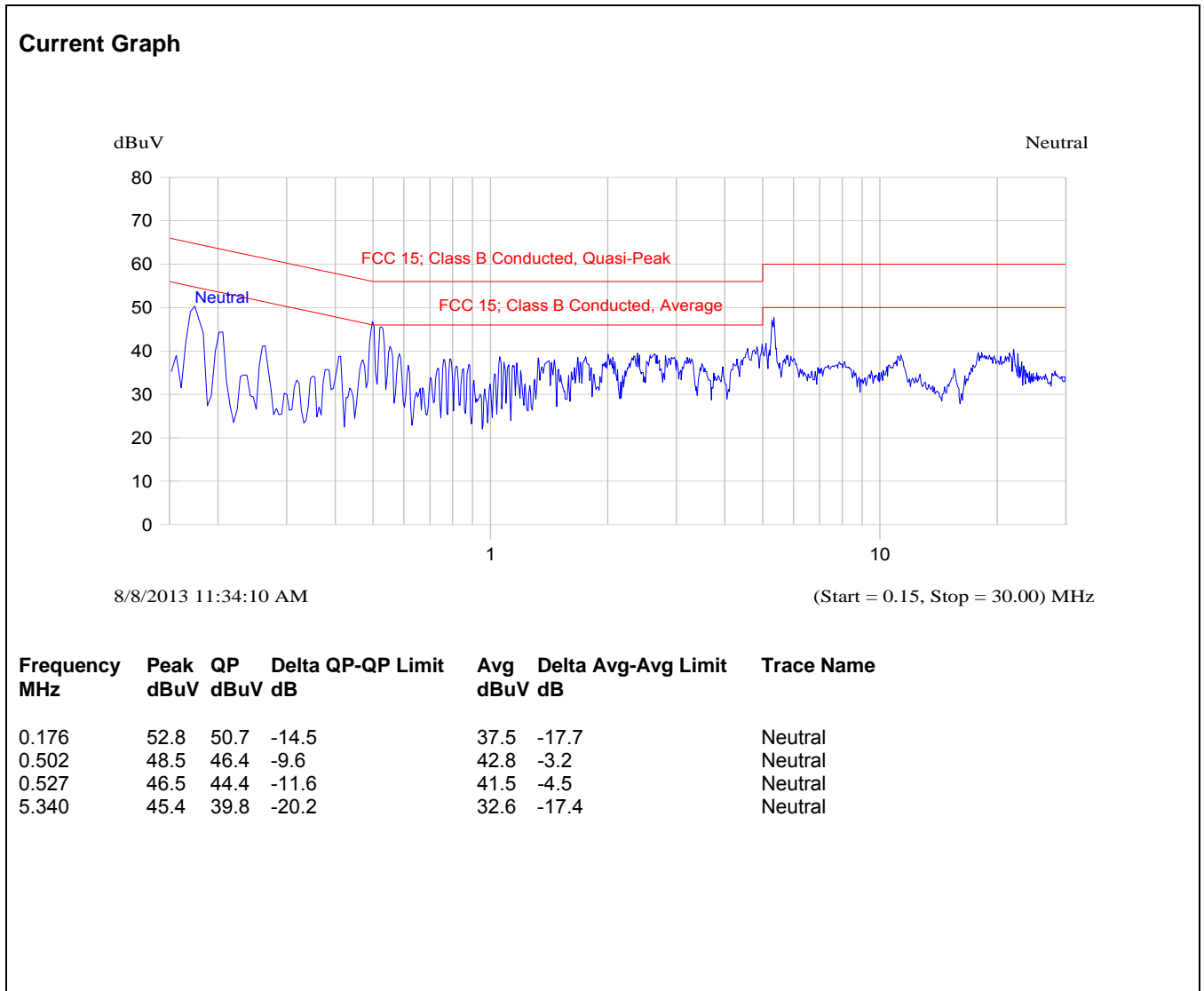

Plot 5.1.4.3. Power Line Conducted Emissions; Line Voltage: 120 VAC; Line Tested: Hot; Rx Mode

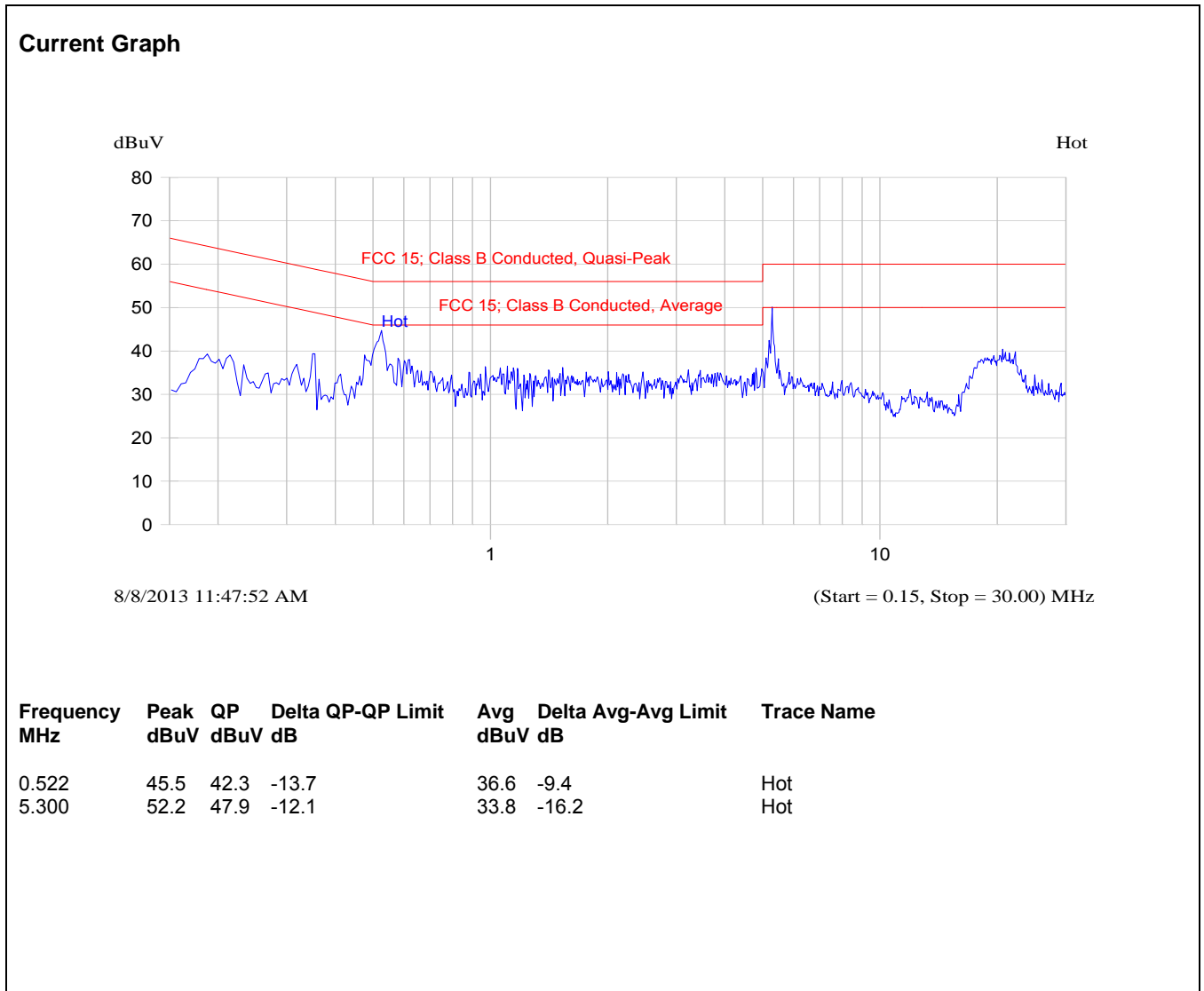

Plot 5.1.4.4. Power Line Conducted Emissions; Line Voltage: 120 VAC; Line Tested: Neutral; Rx Mode

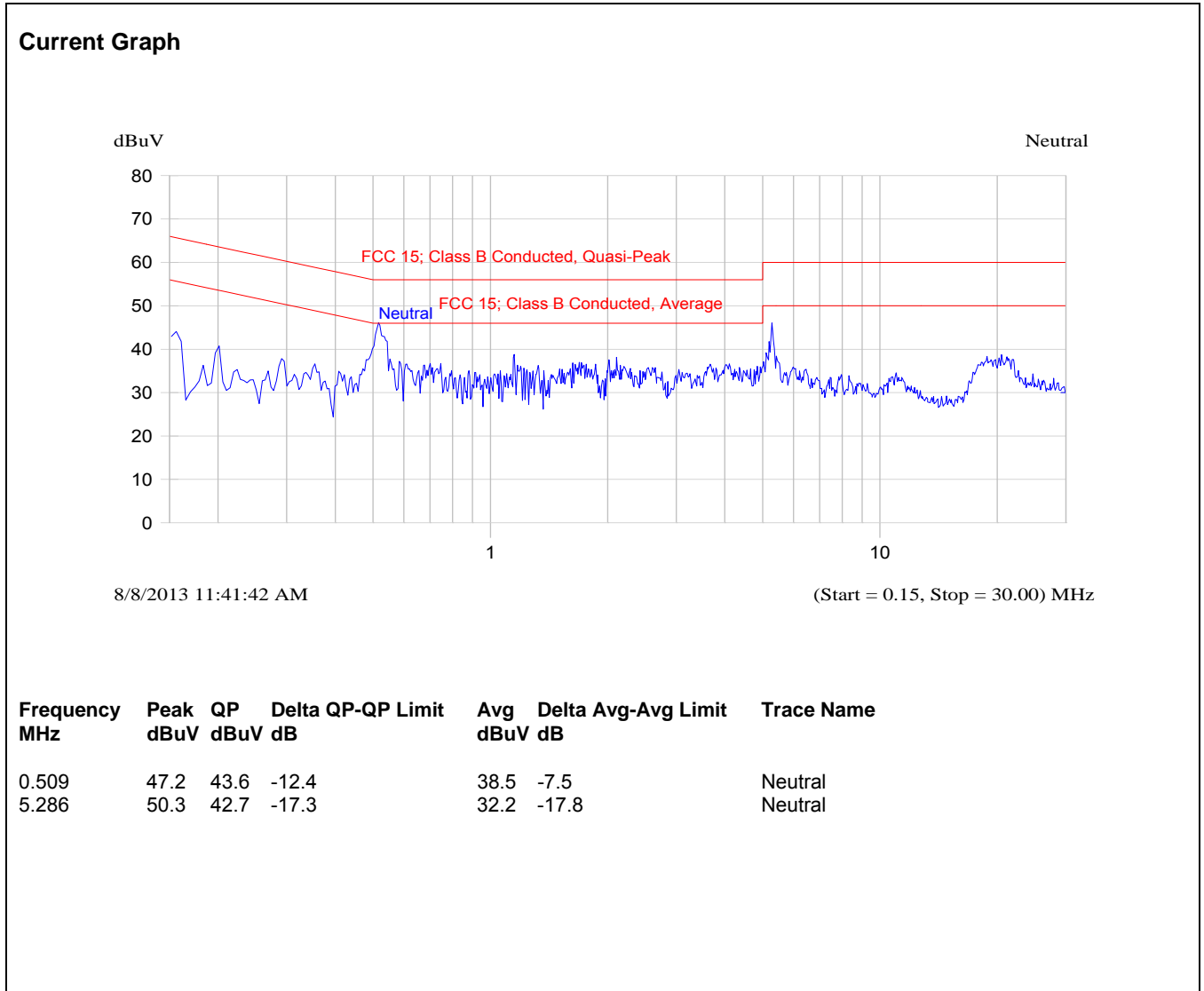

5.2. PEAK CONDUCTED OUTPUT POWER [§§ 15.247(b)(2) & (3), FHSS and DTS]

5.2.1. Limit(s)

§15.247(b)(2): For frequency hopping systems operating in the 902-928 MHz band: 1 watt for systems employing at least 50 hopping channels; and, 0.25 watts for systems employing less than 50 hopping channels, but at least 25 hopping channels.

§ 15.247(b)(3): For systems using digital modulation in the 902-928 MHz, 2400-2483.5 MHz, and 5725-5850 MHz bands: 1 Watt. As an alternative to a peak power measurement, compliance with the one Watt limit can be based on a measurement of the maximum conducted output power. Maximum Conducted Output Power is defined as the total transmit power delivered to all antennas and antenna elements averaged across all symbols in the signaling alphabet when the transmitter is operating at its maximum power control level. Power must be summed across all antennas and antenna elements. The average must not include any time intervals during which the transmitter is off or is transmitting at a reduced power level. If multiple modes of operation are possible (e.g., alternative modulation methods), the *maximum conducted output power* is the highest total transmit power occurring in any mode.

§15.247(b)(4): The conducted output power limit specified in paragraph (b) of this section is based on the use of antennas with directional gains that do not exceed 6 dBi. Except as shown in paragraph (c) of this section, if transmitting antennas of directional gain greater than 6 dBi are used, the conducted output power from the intentional radiator shall be reduced below the stated values in paragraphs (b)(1), (b)(2), and (b)(3) of this section, as appropriate, by the amount in dB that the directional gain of the antenna exceeds 6 dBi.

5.2.2. Method of Measurements

FCC Public Notice DA 00-705, D01 DTS Meas Guidance v03r01 and ANSI C63.10.

5.2.3. Test Arrangement

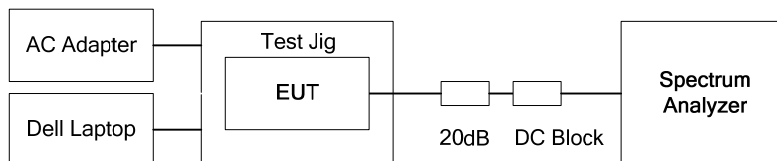

5.2.4. Test Data

Mode of Operation	Modulation Data Rate	Frequency (MHz)	Peak Conducted Power (dBm)	Peak EIRP (dBm)	Peak Conducted Power Limit (dBm)	EIRP Limit (dBm)
FHSS	Data Rate 5	902.4	29.95	See Notes 1 & 2	30	36
		915.0	29.95	See Notes 1 & 2	30	36
		927.6	29.95	See Notes 1 & 2	30	36
DTS	Data Rate 8	903.75	29.84	See Notes 1 & 2	30	36
		915	29.60	See Notes 1 & 2	30	36
		926.25	29.38	See Notes 1 & 2	30	36
	Data Rate 9	904	29.96	See Notes 1 & 2	30	36
		915	29.44	See Notes 1 & 2	30	36
		926	28.99	See Notes 1 & 2	30	36
	Data Rate 10	905	29.98	See Notes 1 & 2	30	36
		915	29.55	See Notes 1 & 2	30	36
		925	28.30	See Notes 1 & 2	30	36
	Data Rate 11	907	29.96	See Notes 1 & 2	30	36
		915	29.95	See Notes 1 & 2	30	36
		923	29.40	See Notes 1 & 2	30	36

Notes:

1. The EIRP shall be calculated based on the transmitter antenna gain (G_{dBi}), cable loss (CL_{dB}) and peak output power at antenna terminal (P_{dBm}). Calculated EIRP = $P_{dBm} + G_{dBi} - CL_{dB}$
2. EIRP shall not exceed 36 dBm limit (Power Setting = $36 \text{ dBm} - G_{dBi} + CL_{dB}$). See Operating Manual for instruction of power setting.

5.3. TRANSMITTER SPURIOUS RADIATED EMISSIONS AT 3 METERS [§§ 15.247(d), 15.209 & 15.205]

5.3.1. Limit

§ 15.247 (d): In any 100 kHz bandwidth outside the frequency band in which the spread spectrum or digitally modulated intentional radiator is operating, the radio frequency power that is produced by the intentional radiator shall be at least 20 dB below that in the 100 kHz bandwidth within the band that contains the highest level of the desired power, based on either an RF conducted or a radiated measurement, provided the transmitter demonstrates compliance with the peak conducted power limits. If the transmitter complies with the conducted power limits based on the use of RMS averaging over a time interval, as permitted under paragraph (b)(3) of this section, the attenuation required under this paragraph shall be 30 dB instead of 20 dB. Attenuation below the general limits specified in Section 15.209(a) is not required. In addition, radiated emissions which fall in the restricted bands, as defined in Section 15.205(a), must also comply with the radiated emission limits specified in Section 15.209(a) (see Section 15.205(c)).

Section 15.205(a) - Restricted Bands of Operation

MHz	MHz	MHz	GHz
0.090–0.110	16.42–16.423	399.9–410	4.5–5.15
¹ 0.495–0.505	16.69475–16.69525	608–614	5.35–5.46
2.1735–2.1905	16.80425–16.80475	960–1240	7.25–7.75
4.125–4.128	25.5–25.67	1300–1427	8.025–8.5
4.17725–4.17775	37.5–38.25	1435–1626.5	9.0–9.2
4.20725–4.20775	73–74.6	1645.5–1646.5	9.3–9.5
6.215–6.218	74.8–75.2	1660–1710	10.6–12.7
6.26775–6.26825	108–121.94	1718.8–1722.2	13.25–13.4
6.31175–6.31225	123–138	2200–2300	14.47–14.5
8.291–8.294	149.9–150.05	2310–2390	15.35–16.2
8.362–8.366	156.52475–156.52525	2483.5–2500	17.7–21.4
8.37625–8.38675	156.7–156.9	2655–2900	22.01–23.12
8.41425–8.41475	162.0125–167.17	3260–3267	23.6–24.0
12.29–12.293	167.72–173.2	3332–3339	31.2–31.8
12.51975–12.52025	240–285	3345.8–3358	36.43–36.5
12.57675–12.57725	322–335.4	3600–4400	(²)
13.36–13.41.			

¹ Until February 1, 1999, this restricted band shall be 0.490–0.510 MHz.

² Above 38.6

Section 15.209(a) - Field Strength Limits within Restricted Frequency Bands

Frequency (MHz)	Field Strength (microvolts/meter)	Measurement Distance (meters)
0.009 - 0.490	2,400 / F (kHz)	300
0.490 - 1.705	24,000 / F (kHz)	30
1.705 - 30.0	30	30
30 – 88	100	3
88 – 216	150	3
216 – 960	200	3
Above 960	500	3

5.3.2. Method of Measurements

ANSI C63.10 and ANSI 63.4 procedures.

5.3.3. Test Arrangement

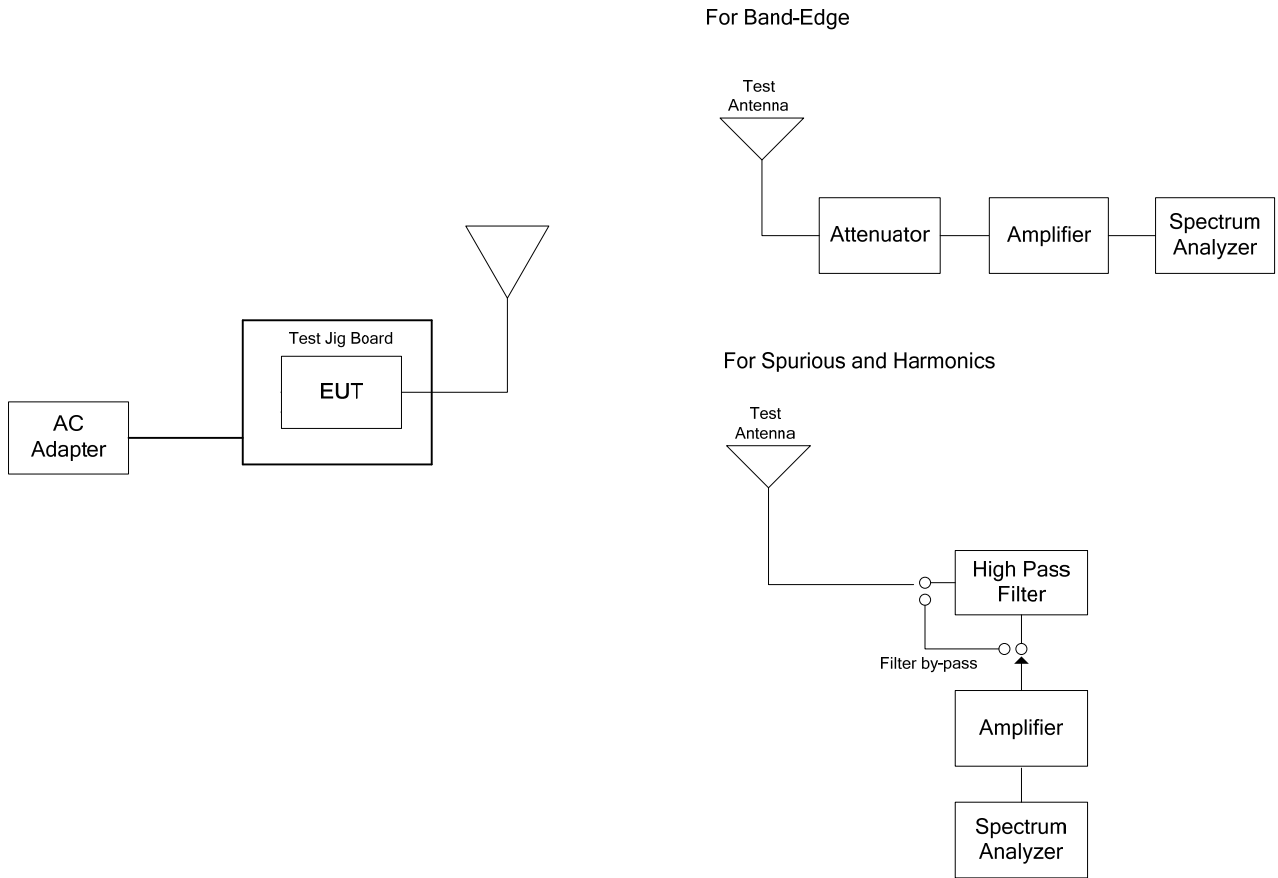

5.3.4. Test Data

Remark(s):

- All spurious emissions that are in excess of 20 dB below the specified limit shall be recorded.
- EUT shall be tested in three orthogonal positions.
- Exploratory tests were performed to determine the worst case and final test configuration, the following test results is the final test configuration with the device operating in FHSS mode at data rate 5.

5.3.4.1. EUT with 8.15 dBi Omni Directional Antenna and 2.49 dB Cable Loss

5.3.4.1.1. Spurious Radiated Emissions

Fundamental Frequency:		902.4 MHz					
Power Setting:		29.95 dBm					
Frequency Test Range:		30 MHz – 10 GHz					
Frequency (MHz)	RF Peak Level (dBµV/m)	RF Avg Level (dBµV/m)	Antenna Plane (H/V)	Limit 15.209 (dBµV/m)	Limit 15.247 (dBµV/m)	Margin (dB)	Pass/Fail
902.4	130.84	--	V	--	--	--	--
902.4	131.11	--	H	--	--	--	--
2707.2	52.33	48.34	V	54.0	111.1	-5.7	Pass*
2707.2	52.65	48.68	H	54.0	111.1	-5.3	Pass*
3609.6	52.80	47.51	V	54.0	111.1	-6.5	Pass*
3609.6	51.75	44.88	H	54.0	111.1	-9.1	Pass*
4512.0	50.27	41.09	V	54.0	111.1	-12.9	Pass*
4512.0	48.72	39.59	H	54.0	111.1	-14.4	Pass*
5414.4	51.03	38.95	V	54.0	111.1	-15.1	Pass*
5414.4	50.38	38.34	H	54.0	111.1	-15.7	Pass*
8121.6	53.69	42.84	V	54.0	111.1	-11.2	Pass*
8121.6	56.33	43.64	H	54.0	111.1	-10.4	Pass*
9024.0	57.76	47.95	V	54.0	111.1	-6.1	Pass*
9024.0	60.75	49.14	H	54.0	111.1	-4.9	Pass*

All other spurious emissions and harmonics are more than 20 dB below the applicable limit.

*Field strength of emissions appearing within restricted frequency bands shall not exceed the limits in § 15.209.

Fundamental Frequency:		915.0 MHz					
Power Setting:		29.95 dBm					
Frequency Test Range:		30 MHz – 10 GHz					
Frequency (MHz)	RF Peak Level (dBµV/m)	RF Avg Level (dBµV/m)	Antenna Plane (H/V)	Limit 15.209 (dBµV/m)	Limit 15.247 (dBµV/m)	Margin (dB)	Pass/Fail
915.0	128.72	--	V	--	--	--	--
915.0	128.21	--	H	--	--	--	--
2745.0	51.35	47.19	V	54.00	108.7	-6.81	Pass*
2745.0	51.51	46.74	H	54.00	108.7	-7.26	Pass*
3660.0	52.09	45.42	V	54.00	108.7	-8.58	Pass*
3660.0	50.57	42.46	H	54.00	108.7	-11.54	Pass*
4575.0	49.84	38.65	V	54.00	108.7	-15.35	Pass*
4575.0	49.41	38.73	H	54.00	108.7	-15.27	Pass*
7320.0	56.48	45.02	V	54.0	108.7	-9.0	Pass*
7320.0	54.87	43.53	H	54.0	108.7	-10.5	Pass*
8235.0	54.26	43.66	V	54.0	108.7	-10.3	Pass*
8235.0	55.65	44.16	H	54.0	108.7	-9.8	Pass*
9150.0	57.87	45.81	V	54.0	108.7	-8.2	Pass*
9150.0	60.47	48.28	H	54.0	108.7	-5.7	Pass*
All other spurious emissions and harmonics are more than 20 dB below the applicable limit.							

*Field strength of emissions appearing within restricted frequency bands shall not exceed the limits in § 15.209.

Fundamental Frequency:		927.6 MHz					
Power Setting:		29.95 dBm					
Frequency Test Range:		30 MHz – 10 GHz					
Frequency (MHz)	RF Peak Level (dBµV/m)	RF Avg Level (dBµV/m)	Antenna Plane (H/V)	Limit 15.209 (dBµV/m)	Limit 15.247 (dBµV/m)	Margin (dB)	Pass/Fail
927.6	130.84	--	V	--	--	--	--
927.6	125.16	--	H	--	--	--	--
2782.8	51.34	46.38	V	54.0	110.8	-7.6	Pass*
2782.8	47.33	40.30	H	54.0	110.8	-13.7	Pass*
3710.4	50.86	42.43	V	54.0	110.8	-11.6	Pass*
3710.4	48.22	40.10	H	54.0	110.8	-13.9	Pass*
4638.0	49.14	37.84	V	54.0	110.8	-16.2	Pass*
4638.0	48.93	37.51	H	54.0	110.8	-16.5	Pass*
7420.8	54.90	42.53	V	54.0	110.8	-11.5	Pass*
7420.8	56.47	44.64	H	54.0	110.8	-9.4	Pass*
8348.4	55.16	43.74	V	54.0	110.8	-10.3	Pass*
8348.4	54.27	43.22	H	54.0	110.8	-10.8	Pass*
All other spurious emissions and harmonics are more than 20 dB below the applicable limit.							

*Field strength of emissions appearing within restricted frequency bands shall not exceed the limits in § 15.209.

5.3.4.1.2. Band-Edge RF Radiated Emissions

Plot 5.3.4.1.2.1. Band-Edge RF Radiated Emissions at 3 m, Horizontal Polarization
Low End of Frequency Band, Single Channel Mode

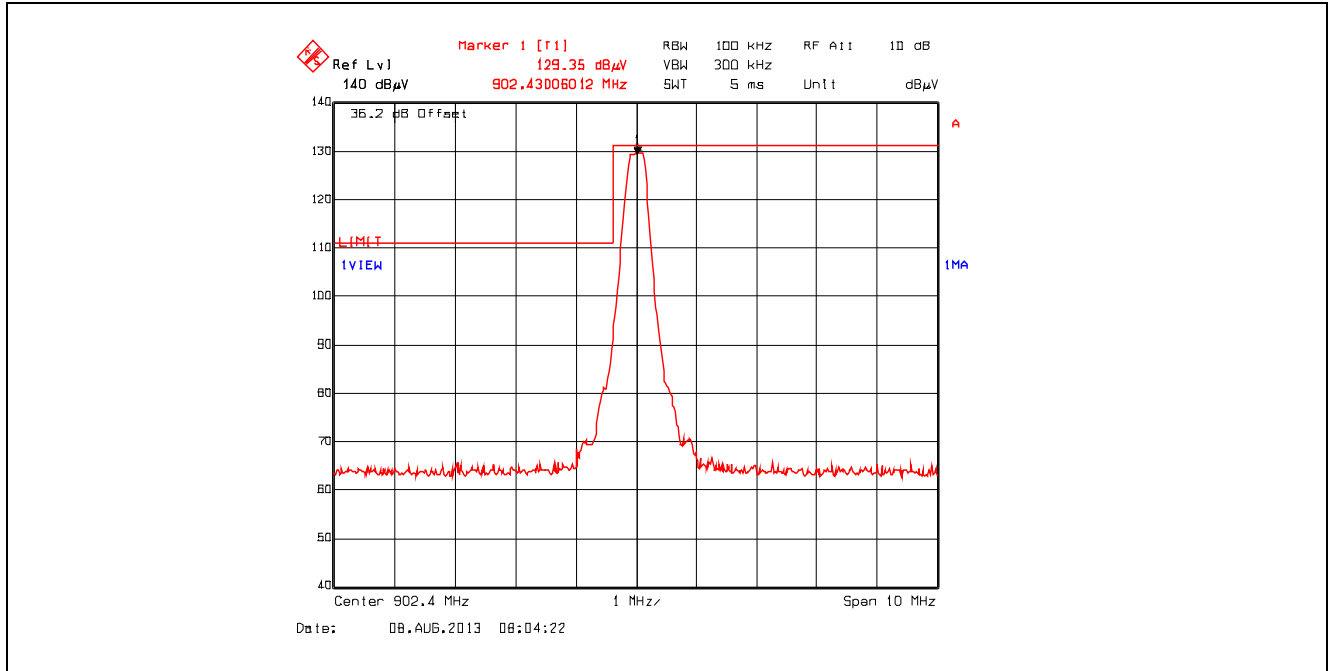

Plot 5.3.4.1.2.2. Band-Edge RF Radiated Emissions at 3 m, Horizontal Polarization
Low End of Frequency Band, Pseudorandom Channel Hopping Mode

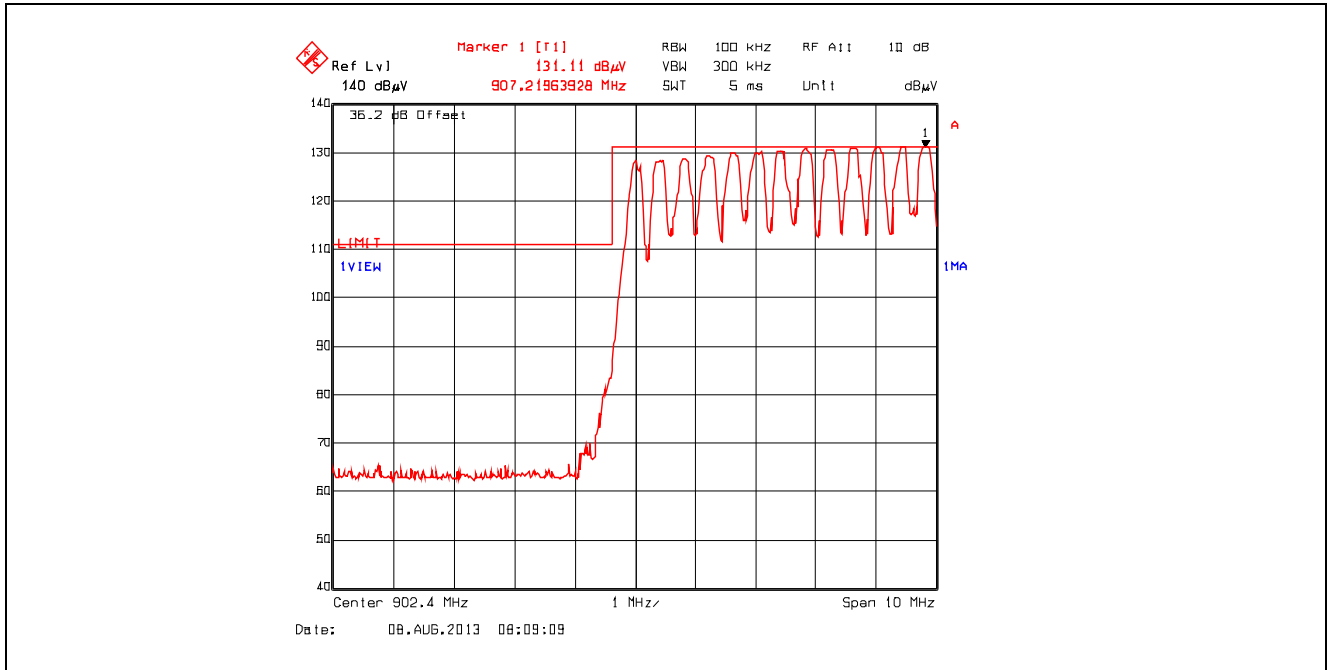

Plot 5.3.4.1.2.3. Band-Edge RF Radiated Emissions at 3 m, Horizontal Polarization
 High End of Frequency Band, Single Channel Mode

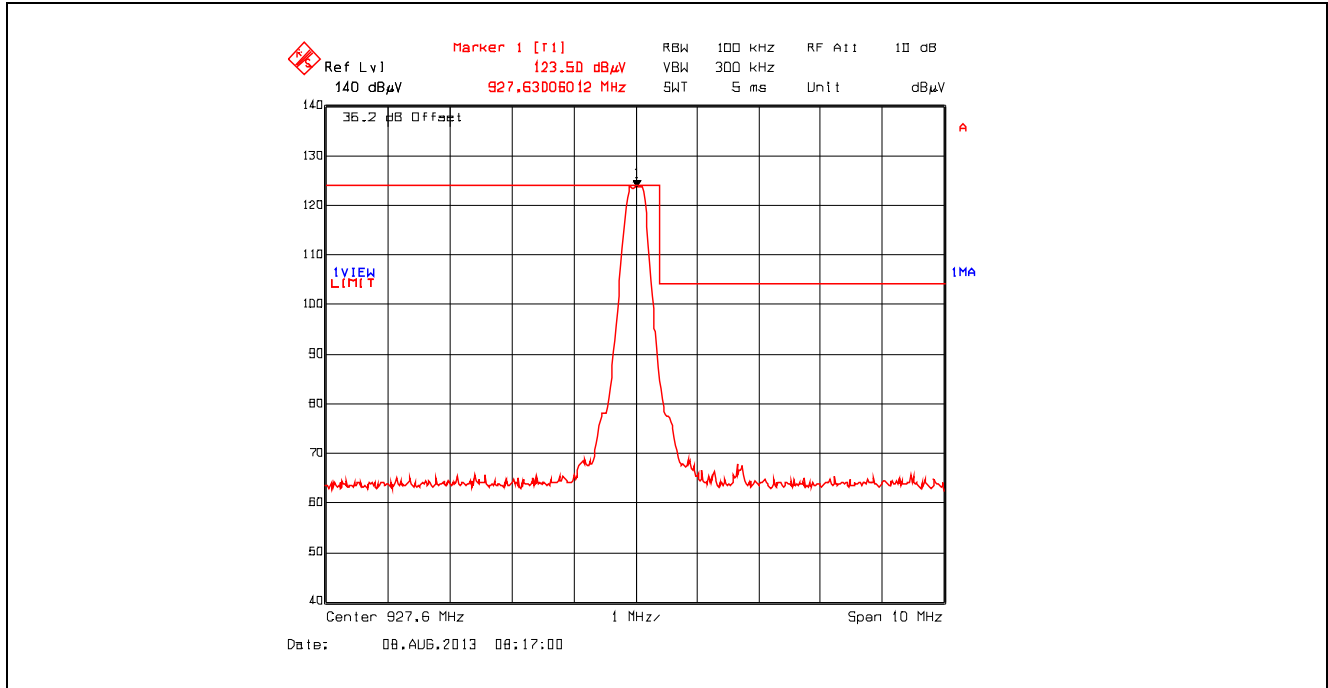

Plot 5.3.4.1.2.4. Band-Edge RF Radiated Emissions at 3 m, Horizontal Polarization
 High End of Frequency Band, Pseudorandom Channel Hopping Mode

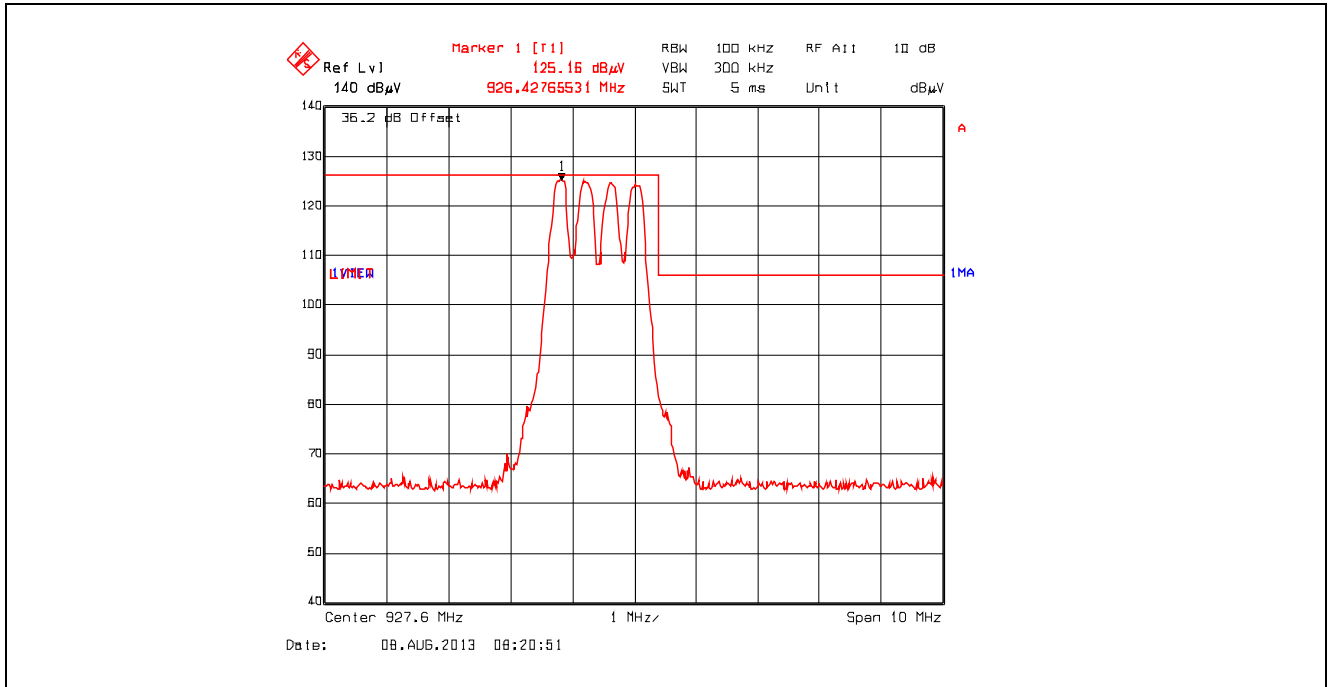

Plot 5.3.4.1.2.5. Band-Edge RF Radiated Emissions at 3 m, Vertical Polarization
 Low End of Frequency Band, Single Channel Mode

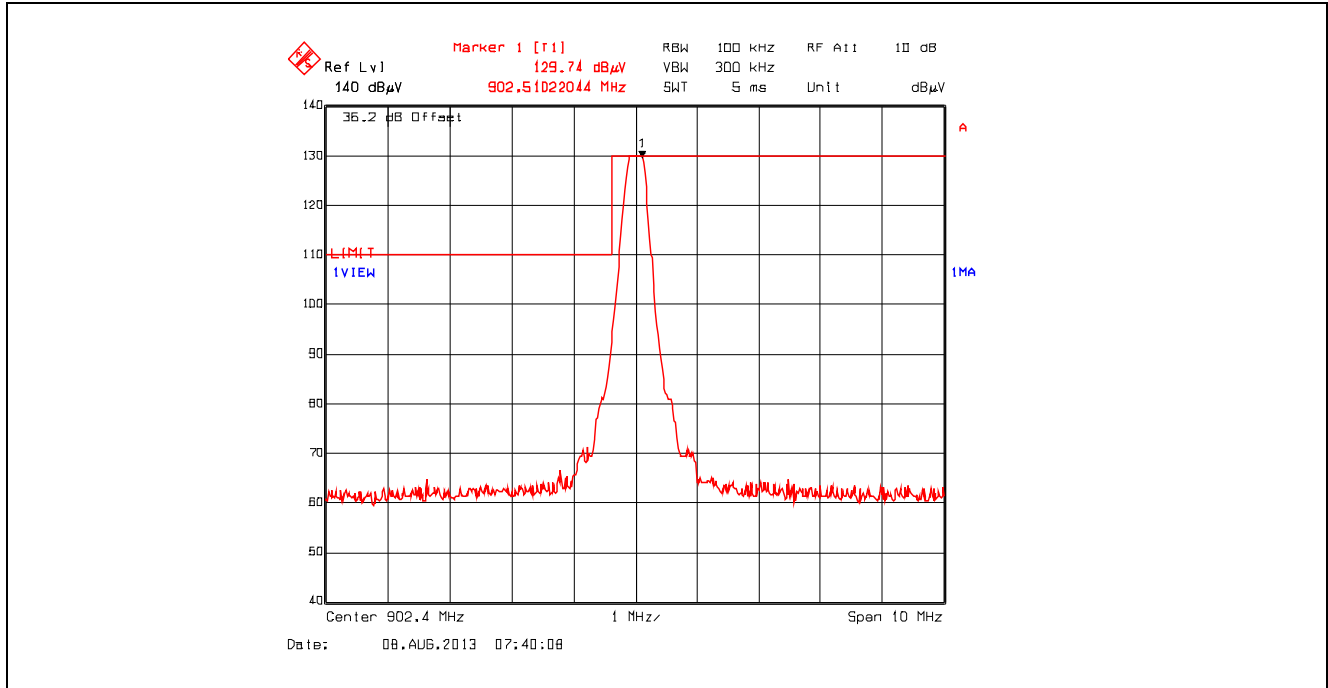

Plot 5.3.4.1.2.6. Band-Edge RF Radiated Emissions at 3 m, Vertical Polarization
 Low End of Frequency Band, Pseudorandom Channel Hopping Mode

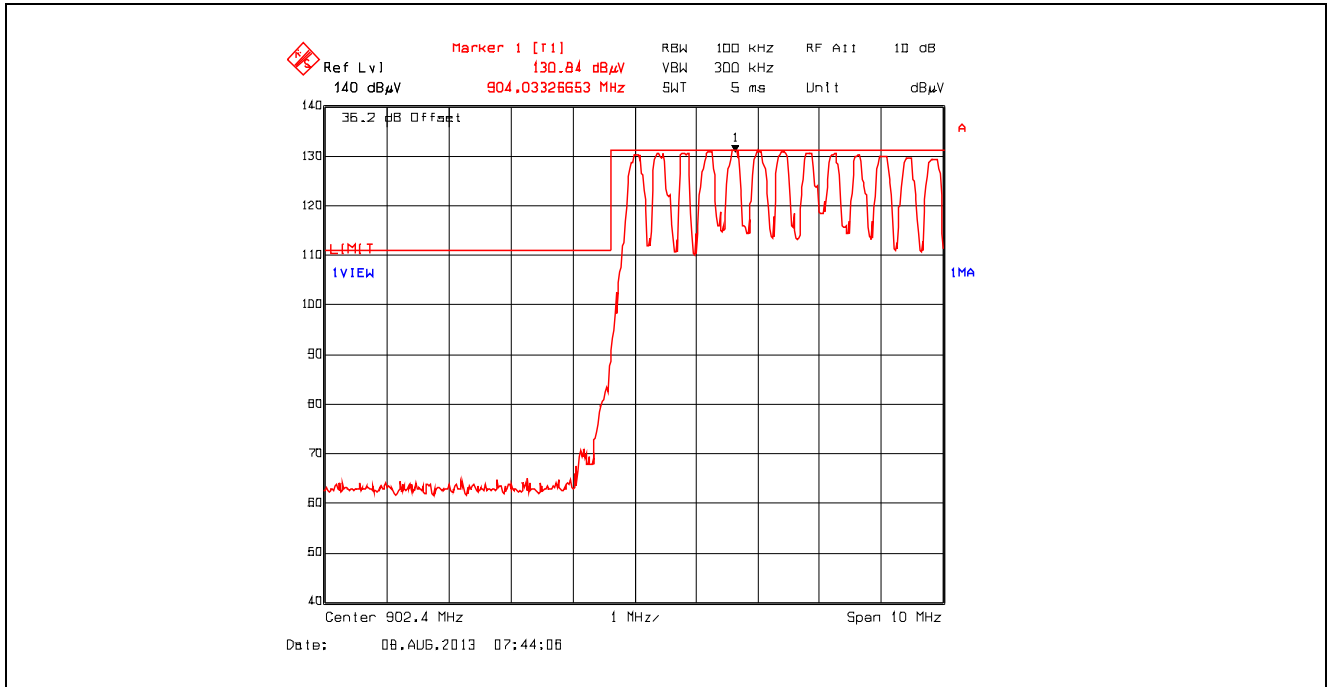

Plot 5.3.4.1.2.7. Band-Edge RF Radiated Emissions at 3 m, Vertical Polarization
 High End of Frequency Band, Single Channel Mode

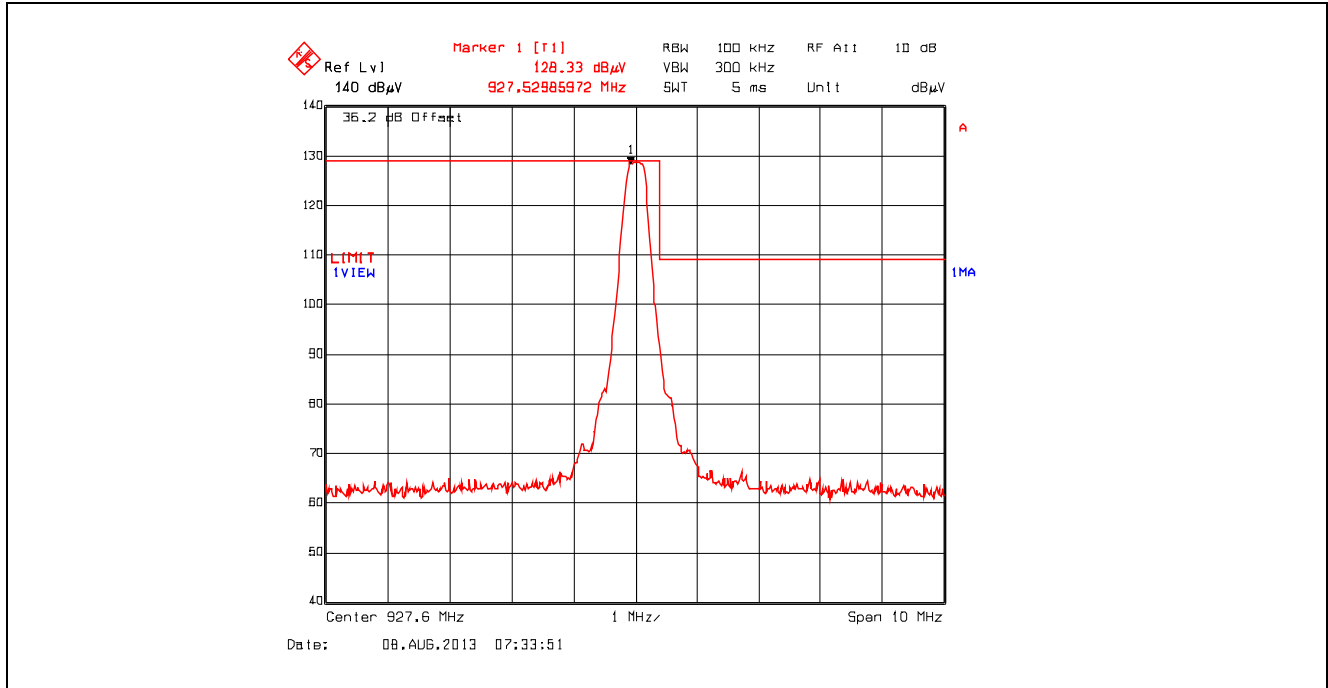

Plot 5.3.4.1.2.8. Band-Edge RF Radiated Emissions at 3 m, Vertical Polarization
 High End of Frequency Band, Pseudorandom Channel Hopping Mode

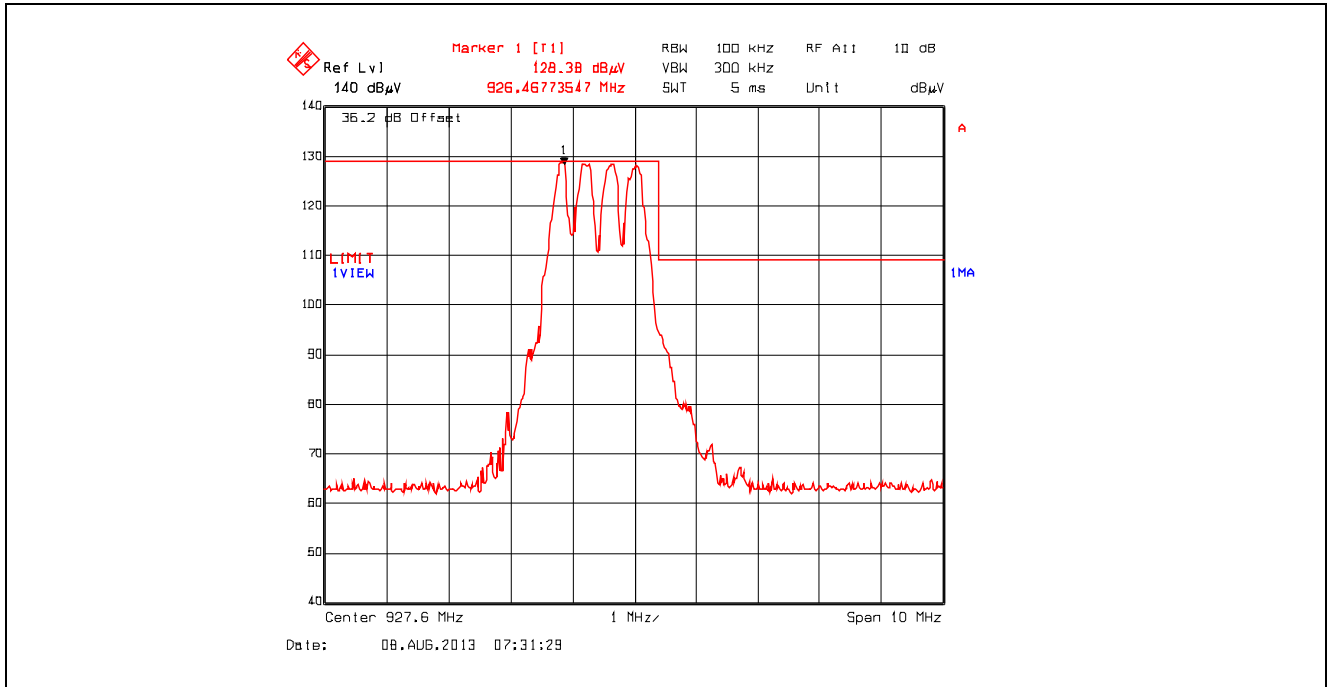

5.4. RF EXPOSURE REQUIRMENTS [§§ 15.247(i), 1.1310 & 2.1091]

The criteria listed in the following table shall be used to evaluate the environmental impact of human exposure to radio-frequency (RF) radiation.

FCC 47 CFR § 1.1310:

TABLE 1—LIMITS FOR MAXIMUM PERMISSIBLE EXPOSURE (MPE)

Frequency range (MHz)	Electric field strength (V/m)	Magnetic field strength (A/m)	Power density (mW/cm ²)	Averaging time (minutes)
(A) Limits for Occupational/Controlled Exposures				
0.3–3.0	614	1.63	*(100)	6
3.0–30	1842/f	4.89/f	*(900/f ²)	6
30–300	61.4	0.163	1.0	6
300–1500	f/300	6
1500–100,000	5	6
(B) Limits for General Population/Uncontrolled Exposure				
0.3–1.34	614	1.63	*(100)	30
1.34–30	824/f	2.19/f	*(180/f ²)	30
30–300	27.5	0.073	0.2	30
300–1500	f/1500	30
1500–100,000	1.0	30

f = frequency in MHz

* = Plane-wave equivalent power density

NOTE 1 TO TABLE 1: Occupational/controlled limits apply in situations in which persons are exposed as a consequence of their employment provided those persons are fully aware of the potential for exposure and can exercise control over their exposure. Limits for occupational/controlled exposure also apply in situations when an individual is transient through a location where occupational/controlled limits apply provided he or she is made aware of the potential for exposure.

NOTE 2 TO TABLE 1: General population/uncontrolled exposures apply in situations in which the general public may be exposed, or in which persons that are exposed as a consequence of their employment may not be fully aware of the potential for exposure or can not exercise control over their exposure.

5.4.1. Method of Measurements

Refer to Sections 1.1310, 2.1091

In order to demonstrate compliance with MPE requirements (see Section 2.1091), the following information is typically needed:

- (1) Calculation that estimates the minimum separation distance (20 cm or more) between an antenna and persons required to satisfy power density limits defined for free space.
- (2) Antenna installation and device operating instructions for installers (professional/unskilled users), and the parties responsible for ensuring compliance with the RF exposure requirement
- (3) Any caution statements and/or warning labels that are necessary in order to comply with the exposure limits
- (4) Any other RF exposure related issues that may affect MPE compliance

Calculation Method of RF Safety Distance:

$$S = \frac{P \cdot G}{4 \cdot \pi \cdot r^2} = \frac{EIRP}{4 \cdot \pi \cdot r^2}$$

Where: P: power input to the antenna in mW
 EIRP: Equivalent (effective) isotropic radiated power
 S: power density mW/cm²
 G: numeric gain of antenna relative to isotropic radiator
 r: distance to centre of radiation in cm

5.4.2. RF Evaluation

Evaluation of RF Exposure Compliance Requirements	
RF Exposure Requirements	Compliance with FCC Rules
Minimum calculated separation distance between antenna and persons required: *23 cm	Manufacturer’ instruction for separation distance between antenna and persons required: 23 cm.
Antenna installation and device operating instructions for installers (professional/unskilled users), and the parties responsible for ensuring compliance with the RF exposure requirement	Antenna installation and device operating instructions shall be provided to installers to maintain and ensure compliance with RF exposure requirements.
Caution statements and/or warning labels that are necessary in order to comply with the exposure limits	Refer to User’s Manual for RF Exposure Information.
Any other RF exposure related issues that may affect MPE compliance	None.

*The minimum separation distance between the antenna and bodies of users are calculated using the following formula:

RF EXPOSURE DISTANCE LIMITS

$$r = \sqrt{\frac{P \cdot G}{4 \cdot \pi \cdot S}} = \sqrt{\frac{EIRP}{4 \cdot \pi \cdot S}}$$

S = 902.4/1500 mW/cm²
 EIRP = 36.0 dBm = 10^{36/10} mW = 3981 mW (Worst Case)

$$\text{(Minimum Safe Distance, r)} = \sqrt{\frac{EIRP}{4 \cdot \pi \cdot S}} = \sqrt{\frac{3981}{4 \cdot \pi \cdot (902.4/1500)}} \approx 23\text{cm}$$

EXHIBIT 6. TEST EQUIPMENT LIST

Test Instruments	Manufacturer	Model No.	Serial No.	Frequency Range	Cal. Due Date
Spectrum Analyzer	Hewlett Packard	HP 8593EM	3412A00103	9 kHz–26.5 GHz	06 Feb 2014
Attenuator	Pasternack	PE7010-20	-	DC–2 GHz	11 Jan 2014
L.I.S.N	EMCO	3825/2	8907-1531	0.01 -100 MHz	14 May 2014
Spectrum Analyzer	Rohde & Schwarz	FSEK30	100077	20Hz–40 GHz	02 Nov 2013
Attenuator	Pasternack	PE7024-20	6	DC–26.5 GHz	Cal on use
DC Block	Hewlett Packard	11742A	12460	0.045–26.5 GHz	Cal on use
Spectrum Analyzer	Rohde & Schwarz	ESU40	100033	20 Hz – 40 GHz	07 Mar 2014
RF Amplifier	Hewlett Packard	84498	3008A00769	1 – 26.5 GHz	25 Jun 2014
RF Amplifier	AH System	PAM-0118	225	20 MHz – 18 GHz	25 Mar 2014
High Pass Filter	K & L	11SH10-4000/T12000	4	Cut off 2.4 GHz	Cal on use
Horn Antenna	EMCO	3155	6570	1 – 18 GHz	07 Jun 2014
Horn Antenna	EMCO	3160-09	118385	18 – 26.5 GHz	30 Jul 2014
Attenuator	Pasternack	PE7024-10	4	DC–26.5 GHz	Cal on use
Horn Antenna	EMCO	3155	5955	1 – 18 GHz	07 Mar 2014
Spectrum Analyzer	Rohde & Schwarz	ESU40	100033	20 Hz – 40 GHz	07 Mar 2014
RF Amplifier	Hewlett Packard	84498	3008A00769	1 – 26.5 GHz	25 Jun 2014
Biconi-Log Antenna	ETS Lindgren	3142B	1575	26 – 3000 MHz	26 Jun 2014

ULTRATECH GROUP OF LABS

3000 Bristol Circle, Oakville, Ontario, Canada L6H 6G4
 Tel. #: 905-829-1570, Fax. #: 905-829-8050, Email: vic@ultratech-labs.com, Website: <http://www.ultratech-labs.com>

File #: MCRS-066F15C247
 September 11, 2013

All test results contained in this engineering test report are traceable to National Institute of Standards and Technology (NIST)

EXHIBIT 7. MEASUREMENT UNCERTAINTY

The measurement uncertainties stated were calculated in accordance with the requirements of CISPR 16-4-2 @ IEC:2003 and JCGM 100:2008 (GUM 1995) – Guide to the Expression of Uncertainty in Measurement.

7.1. LINE CONDUCTED EMISSION MEASUREMENT UNCERTAINTY

	Line Conducted Emission Measurement Uncertainty (9 kHz – 30 MHz):	Measured	Limit
u_c	Combined standard uncertainty: $u_c(y) = \sqrt{\sum_{i=1}^m u_i^2(y)}$	± 1.44	± 1.8
U	Expanded uncertainty U: $U = 2u_c(y)$	± 2.89	± 3.6

7.2. RADIATED EMISSION MEASUREMENT UNCERTAINTY

	Radiated Emission Measurement Uncertainty @ 3m, Horizontal (30-1000 MHz):	Measured (dB)	Limit (dB)
u_c	Combined standard uncertainty: $u_c(y) = \sqrt{\sum_{i=1}^m u_i^2(y)}$	± 2.39	± 2.6
U	Expanded uncertainty U: $U = 2u_c(y)$	± 4.79	± 5.2

	Radiated Emission Measurement Uncertainty @ 3m, Vertical (30-1000 MHz):	Measured (dB)	Limit (dB)
u_c	Combined standard uncertainty: $u_c(y) = \sqrt{\sum_{i=1}^m u_i^2(y)}$	± 2.39	± 2.6
U	Expanded uncertainty U: $U = 2u_c(y)$	± 4.78	± 5.2

	Radiated Emission Measurement Uncertainty @ 3 m, Horizontal & Vertical (1 – 18 GHz):	Measured (dB)	Limit (dB)
u_c	Combined standard uncertainty: $u_c(y) = \sqrt{\sum_{i=1}^m u_i^2(y)}$	± 1.87	Under consideration
U	Expanded uncertainty U: $U = 2u_c(y)$	± 3.75	Under consideration