

**MICROHARD SYSTEMS, INC.
FCC INFORMATION**

RF Measurement Report

Prepared by:

National Certification Laboratory

**8370 Court Avenue, Suite B-1
Ellicott City, Maryland 21043
(410) 461-5548**

In Support of:

FCC APPLICATION FOR CERTIFICATION

For:

**Microhard Systems, Inc.
#110, 1144-29th Avenue, NE
Calgary
Alberta, Canada T2E 7P1**

Model: MHX-920E

FCCID: NS901P6

Demonstration of Compliance with FCC Rules Part 15.247

No part of this report may be reproduced without written approval of National Certification Laboratory

February 22, 2001

TABLE OF CONTENTS

1.0 General Information	5
1.1 Summary	
1.2 Test Methodology.....	5
1.3 Test Facility.....	5
2.0 Description of Equipment Under Test (EUT)	6
2.1 EMI Countermeasure	7
3.0 Test Program	
4.0 Test Configuration For Antenna Terminal Conducted	8
4.1 Peak Power Test Results.....	9
4.1.1 Peak Power Modulated Carrier (1 MHz Res. BW) Low Channel Plot.....	10
4.1.2 Peak Power Modulated Carrier (1 MHz Res. BW) Mid Channel Plot.....	11
4.1.3 Peak Power Modulated Carrier (1 MHz Res. BW) High Channel Plot.....	12
4.2 20 dB Emission Bandwidth Test Results.....	13
4.2.1 20 dB Bandwidth Emissions (3 kHz Res. BW) Low Channel Plot	14
4.2.2 20 dB Bandwidth Emissions (3 kHz Res. BW) Mid Channel Plot.....	15
4.2.3 20 dB Bandwidth Emissions (3 kHz Res. BW) High Channel Plot.....	16
4.3 RF Antenna Conducted Spurious/Harmonics Emissions.....	17
4.3.1 FCC Part 15.247(c) Conducted Spurious, 902.47 MHz Frequency Of Carrier	18
4.3.2 FCC Part 15.247(c) Conducted Spurious, 914.8 MHz Frequency of Carrier	19
4.3.3 FCC Part 15.247(c) Conducted Spurious,927.6 MHz Frequency of Carrier	20
4.3.4 Conducted Harmonics Emissions (100kHz Res. BW) Low Cannel Plot.....	21
4.3.5 Conducted Harmonics Emissions (100kHz Res. BW) Mid Cannel Plot	22
4.3.6 Conducted Harmonics Emissions (100kHz Res. BW) High Cannel Plot.....	23
4.4 Conducted Bandedge Emissions Test Results	24
4.4.1 Low Channel Conducted Bandedge Emissions Plot.....	24
4.4.2 High Channel Conducted Bandedge Emissions Plot	25
4.5 Channel Occupancy Test Results.....	26

4.6	UT Average Time of Channel Occupancy and Dwell Time.....	27
4.7	Hopping Dwell Time.....	28
5.0	Test Configuration For Conducted And Radiated Emissions	29
6.0	A.C. Conducted Emissions Scheme	29
6.1	AC Conducted Emissions Data Table	30
7.0	Radiated Emissions Scheme	31
7.1	Yagi Antenna, 902.8 MHz, 100mW Radiated Emissions Data Table	32
7.2	Yagi Antenna, 914.7 MHz, 100mW Radiated Emissions Data Table	33
7.3	Yagi Antenna, 927.1 MHz,100mW Radiated Emissions Data Table	34
7.4	6 dBi Omni Antenna, 902.8 MHz, 1000mW Radiated Emissions Data Table.....	35
7.5	6 dBi Omni Antenna, 914.7 MHz, 1000mW Radiated Emissions Data Table.....	36
7.6	6 dBi Omni Antenna, 927.1 MHz, 1000mW Radiated Emissions Data Table.....	37
7.7	Receiver, 915 MHz Radiated Emissions Data Table	38
8.0	RF Exposure Statement.....	39

TABLES

Table 1	EUT Accessories.....	41
Table 2	Support Equipment.....	42
Table 3	Measurement Equipment Used.....	43

EXHIBITS

Exhibit 1	Measurement Photographs	44
Exhibit 1.1	AC Conducted Emissions Measurement Photographs.....	44
Exhibit 1.2	Radiated Emissions Measurement Photographs	46
Exhibit 2	Schematic	47
Exhibit 3	User’s Manual.....	48

NCL PROJ.# MICROHARD-576

1.0 General Information:

This report has been prepared on behalf of **Microhard Systems, Inc.**, to support the attached Application for a Certification of a Part 15 Spread Spectrum Transmitter module. The Equipment Under Test (EUT) was the **Model: MHX-920E Wireless Modem Transceiver OEM Module**. The EUT configuration consisted of an Omni directional antenna, one twelve volt AC-DC power supply, and 50 ohm low loss cable. The test results reported in this document relate only to the item that was tested.

Radio-Noise Emissions tests were performed according to *FCC Public Notice 54797, titled "Guidance on Measurement for Direct Sequence SST"*. The measuring equipment conforms to ANSI C63.2 Specifications for Electromagnetic Noise and Field Strength Instrumentation.

1.1 Summary:

The Microhard Systems, Inc., **MHX-920E Wireless Modem Transceiver OEM Module**, and a suite of specific antennas complies with the FCC limits (15.247) for a Frequency Hopping SST. Tests were performed on radio channels 1, 27, and 54. These are referred to in the report as the low, mid and high channels respectively.

1.2 Test Methodology:

Both conducted and radiated testing were performed according to the procedures in ANSI C63.4 1992. Radiated testing was performed at an antenna to EUT distance of three (3) meters.

1.3 Test Facility:

The open area test site and conducted measurement facility used to collect the radiated data is located on the parking lot of National Certification Laboratory 8370 Court Avenue, Suite B-1, Ellicott City, Maryland 21043. This site has been fully described in a report dated May 26, 1993, submitted to and approved by the Federal Communications Commission to perform AC line conducted and radiated emissions testing.

2.0 Description of Equipment Under Test (EUT):

The EUT features:

MCX Antenna Connector per 15.203

+30 dBm Peak RF Output

902 to 928 MHz Frequency Range

350 kHz, 20 dB Emission Bandwidth

50 Hopping Channels

400 kHz Channel Separation

172.8 kbps Data Rate (Radio Link)

115.2 kbps Max Data Rate (DCE)

2.1 EMI Countermeasure:

The following modifications were made to the EUT, by the project engineer to assure compliance to specifications:

None.

3.0 Test Program:

This report contains measurement charts and data as evidence for the following tests performed:

1. (15.247b) Peak RF output power.
2. (15.247a) 20 dB Emission Bandwidth.
3. (15.247c) RF Antenna Conducted output of harmonics and spurious out-of-band emissions.
4. (15.247c) Field Strength of harmonics and spurious out-of-band emissions.
5. (15.207) AC Power Line Conducted emissions.
6. (15.247c) Band Edge emissions.
7. (15.247b) Average Channel Dwell Time.

4.0 Test Configuration for Antenna Terminal Conducted:

RF antenna conducted output tests such as Bandwidth, Spurious/Harmonics, and Power output were taken with the antenna connector feeding directly into the spectrum analyzer via external **20 dB attenuator**. The analyzer's internal attenuator was adjusted to prevent overloading of the front end. The transmitter is modulated at 115.2 kbps which is the highest available data rate..

Field strength measurements were taken with the transmitter feeding a Yagi or Omni antenna aimed at the receiving antenna. Testing was performed using the highest gain antenna from each design family (Yagi, Omni) with the power setting at 1 Watt for the Omni antenna, and 100 mW for the higher gain Yagi.

A list of all antennas that will be sold with the EUT is provided in Table 1.

4.1 Peak Power Test Results:

Limit: 1 watt (30 dBm)

Condition: Transmitter is set to a single modulated channel at full power.

Readings from spectrum analyzer with 1MHz Resolution Bandwidth setting:

Low Channel:	902.47 MHz	(+29.8 dBm)
Mid Channel:	914.83 MHz	(+30.0 dBm)
High Channel:	927.61 MHz	(+29.8 dBm)

SEE FOLLOWING THREE (3) PLOTS OF MODULATED CARRIER

4.1.1 Peak Power Modulated Carrier (1 MHz Res. BW) Low Channel Plot:

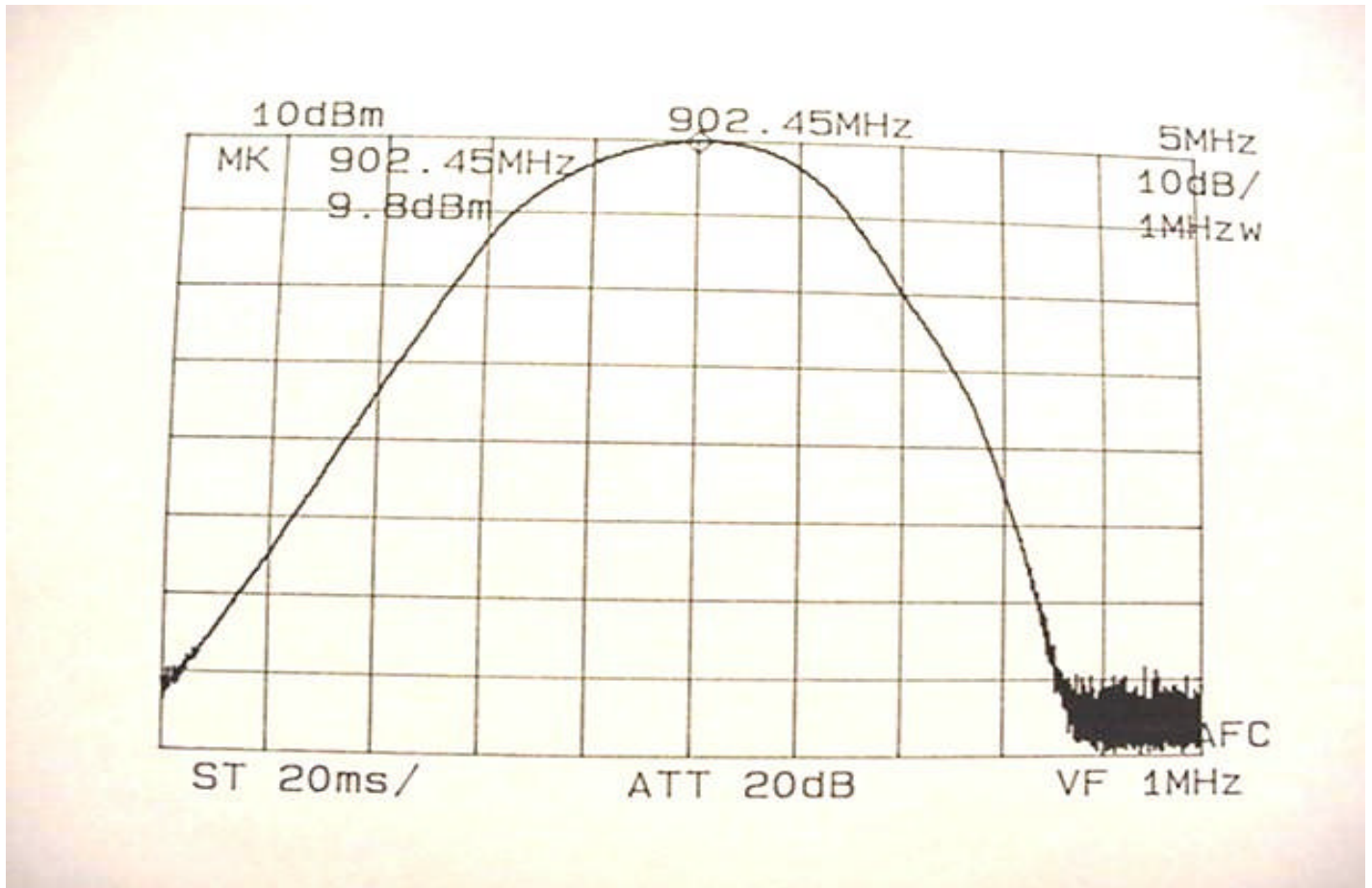

4.1.2 Peak Power Modulated Carrier (1 MHz Res. BW) Mid Channel Plot:

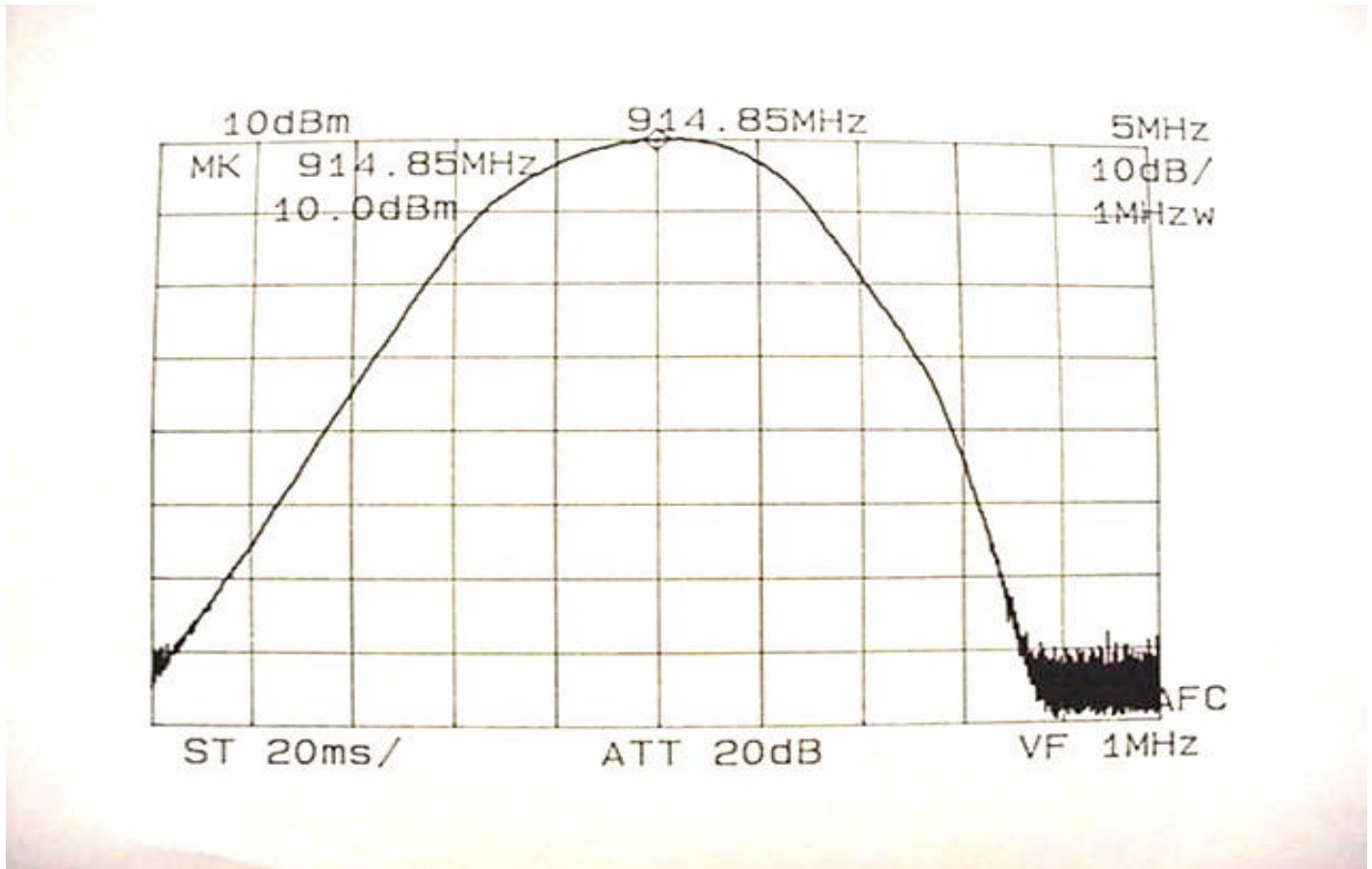

4.1.3 Peak Power Modulated Carrier (1 MHz Res. BW) High Channel Plot:

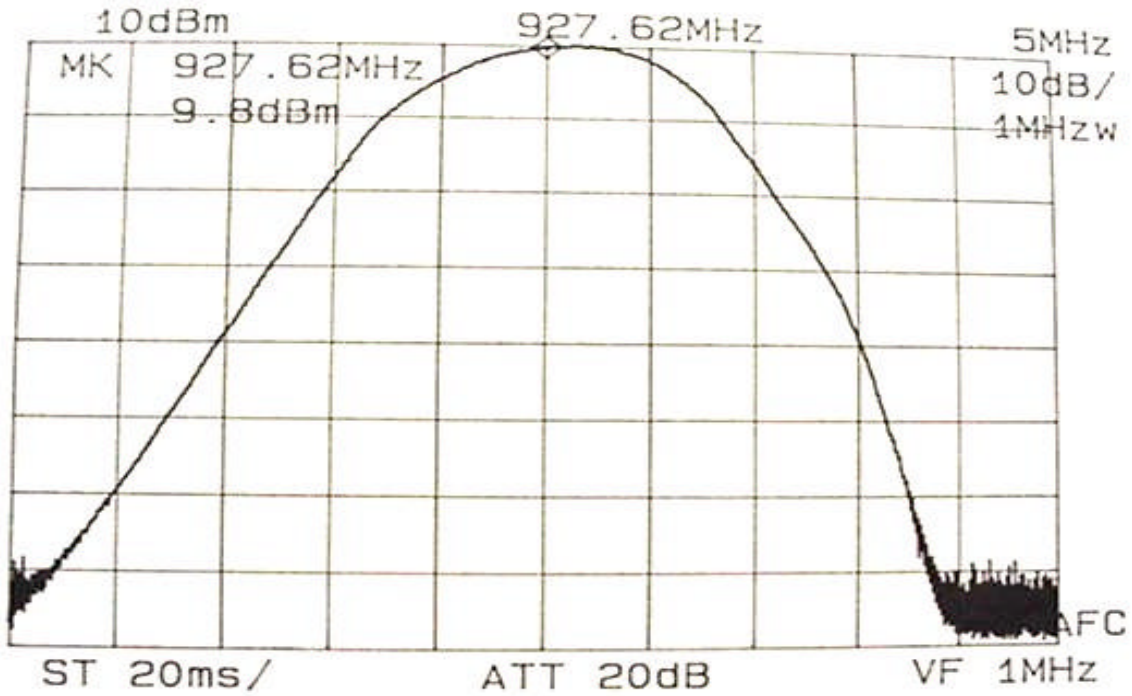

4.2 20 dB Emission Bandwidth Test Results:

Minimum 20 dB BW: 0.500 MHz
RBW Setting on S.A.: 3 kHz

Condition: Transmitter is set to a single modulated channel at 115.2 kbps.

Readings from Spectrum Analyzer:

Channel 1:	902.47 MHz	348 kHz
Channel 25:	914.83 MHz	349 kHz
Channel 50:	927.61 MHz	350 kHz

SEE FOLLOWING THREE (3) PLOTS OF MODULATED CARRIER

4.2.1 20 dB Bandwidth Emissions (3 kHz Res. BW) Low Channel Bandwidth Plot:

20 dB EMISSION BANDWIDTH – MODULATED CARRIER
Low Channel

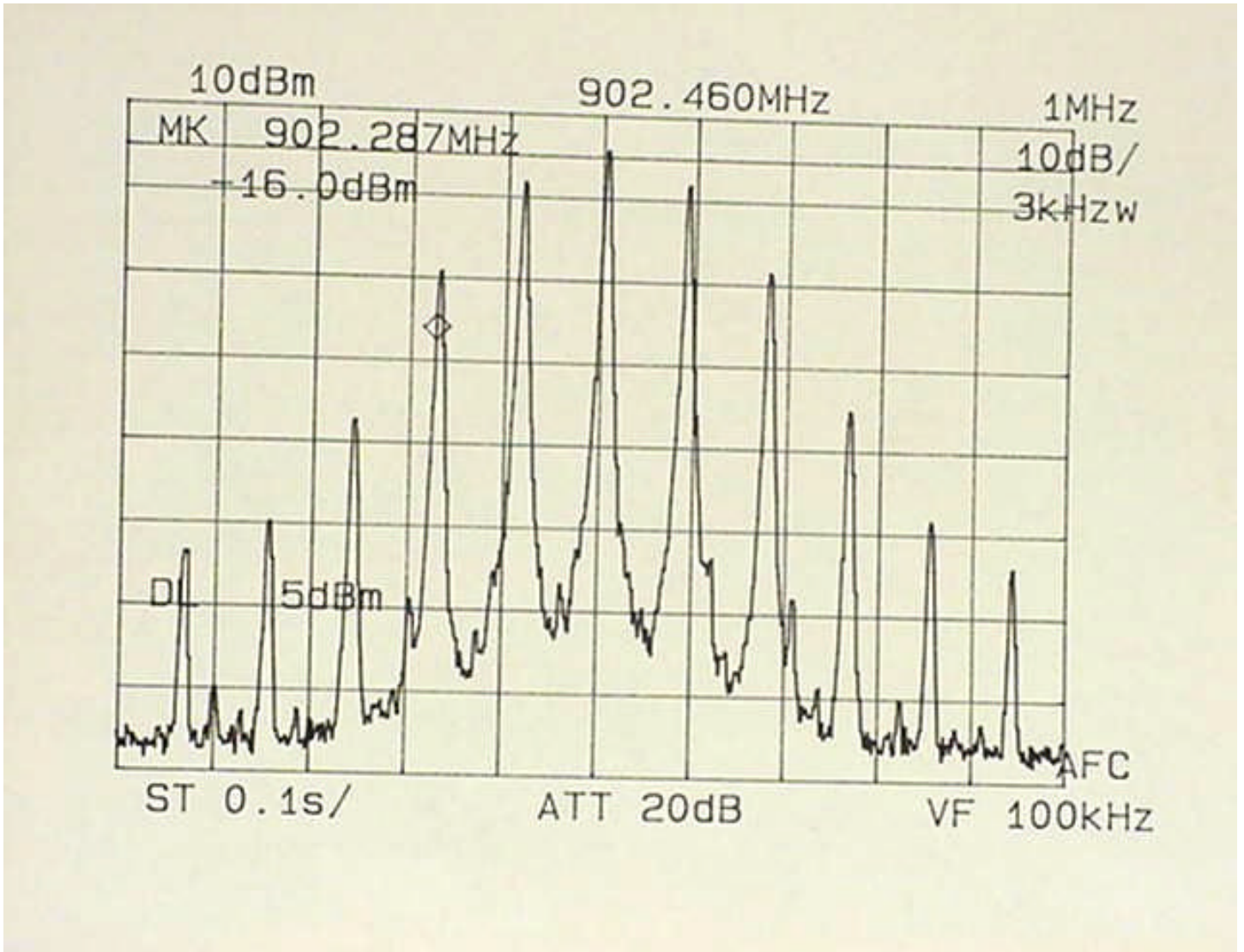

4.2.2 20 dB Bandwidth Emissions (3 kHz Res. BW) Mid Channel Bandwidth Plot:

20 dB EMISSION BANDWIDTH – MODULATED CARRIER
Mid Channel

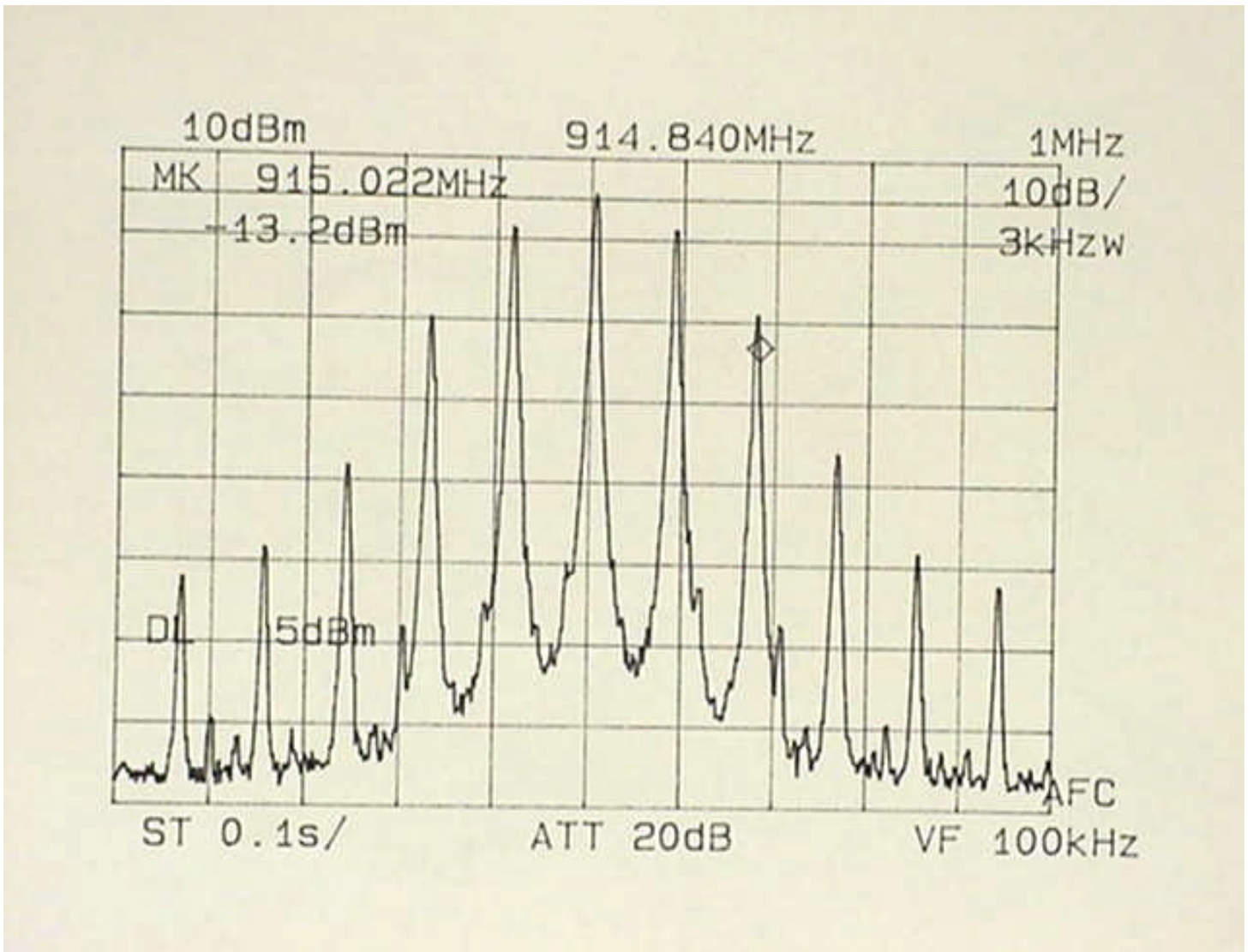

4.2.3 20 dB Bandwidth Emissions (3 kHz Res. BW) High Channel Bandwidth Plot:

20 dB EMISSION BANDWIDTH – MODULATED CARRIER
High Channel

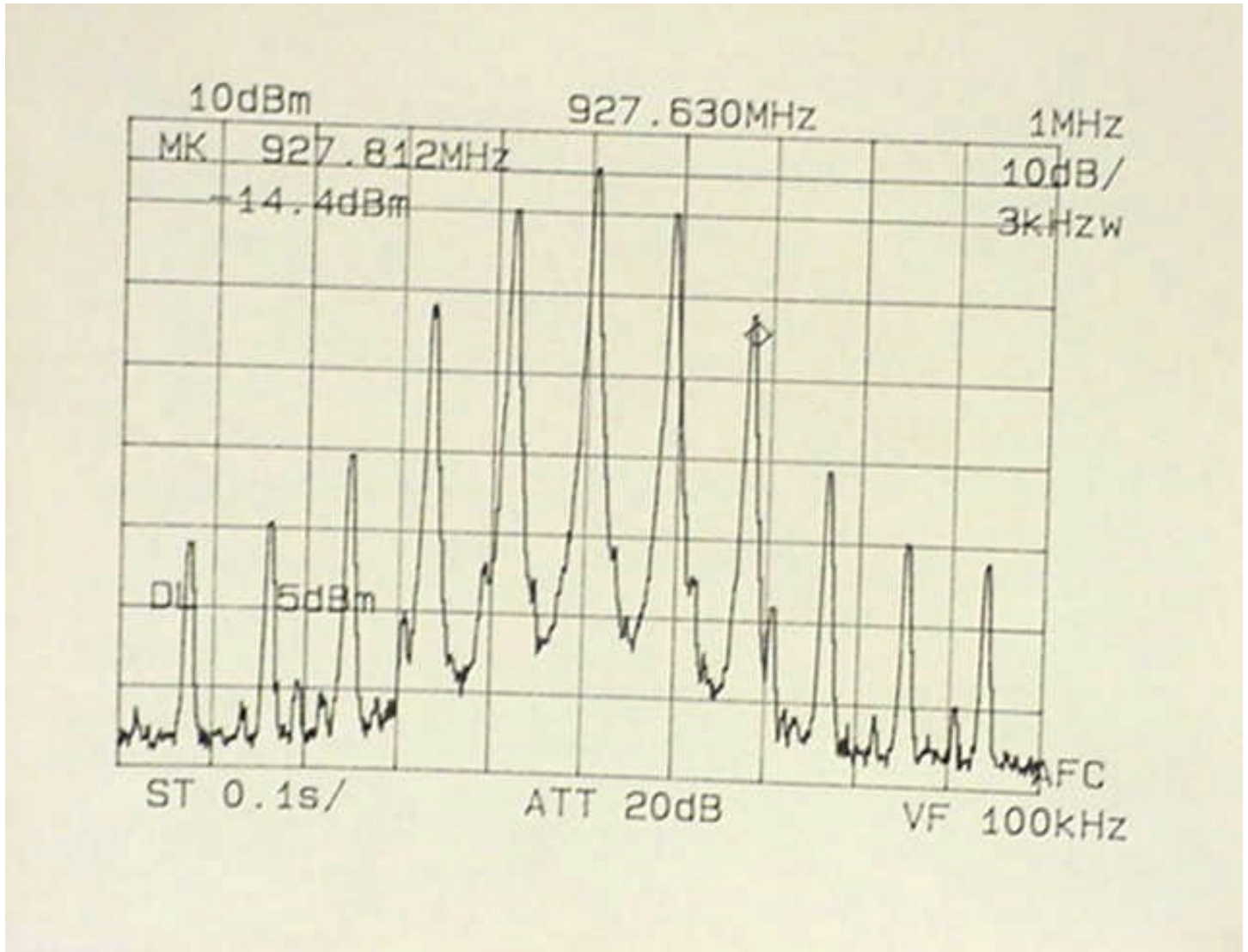

4.3 RF Antenna Conducted Spurious/Harmonics Emissions:

Limit: 20 dB below Carrier Level Measured with 100 kHz RBW
RBW Setting on S.A.: 100 kHz

Condition: Transmitter is set to a single modulated channel.
RF Power = 30 dBm

Three separate measurements are performed to show harmonic and spurious emissions generated with the transmitter tuned to low, middle, and high parts of the spectral range.

SEE FOLLOWING THREE (3) PLOTS & DATA TABLES

4.3.1 FCC Part 15.247(c) Conducted Spurious, 902.47 MHz Frequency Of Carrier:

Frequency of Carrier = 902.47 MHz

Limit = 20 dBc

Condition: Transmitter is set to a single FM modulated channel.

TEST RESULTS

LIMIT: -20 dB FROM PEAK CARRIER

<u>Component</u>	<u>Frequency (MHz)</u>	<u>Result (dBc)</u>
Harmonic	1805.60	-52.0
Harmonic	2708.40	-63.0
Harmonic	3611.20	-66.0
Harmonic	4514.00	-70.0
Harmonic	5416.80	-70.0
Harmonic	6319.60	-72.0
Harmonic	7222.40	-75.0
Harmonic	8125.20	-75.0
Harmonic	9028.00	-75.0

4.3.2 FCC Part 15.247(c) Conducted Spurious, 914.8 MHz Frequency of Carrier:

Frequency of Carrier = 914.8 MHz

Limit = 20 dBc

Condition: Transmitter is set to a single FM modulated channel.

TEST RESULTS

LIMIT: -20 dB FROM PEAK CARRIER

<u>Component</u>	<u>Frequency (MHz)</u>	<u>Result (dBc)</u>
Harmonic	1829.40	-50.0
Harmonic	2744.10	-61.0
Harmonic	3658.80	-66.0
Harmonic	4573.50	-71.0
Harmonic	5488.20	-71.0
Harmonic	6402.90	-73.0
Harmonic	7317.6	-75.0
Harmonic	8232.30	-75.0
Harmonic	9147.00	-75.0

4.3.3 FCC Part 15.247(c) Conducted Spurious, 927.6 MHz Frequency of Carrier:

Frequency of Carrier = 927.6 MHz

Limit = 20 dBc

Condition: Transmitter is set to a single FM modulated channel.

TEST RESULTS

LIMIT: -20 dB FROM PEAK CARRIER

<u>Component</u>	<u>Frequency (MHz)</u>	<u>Result (dBc)</u>
Harmonic	1854.20	-52.0
Harmonic	2781.30	-61.0
Harmonic	3708.40	-65.0
Harmonic	4635.50	-67.0
Harmonic	5562.60	-71.0
Harmonic	6489.70	-74.0
Harmonic	7416.80	-74.0
Harmonic	8343.90	-75.0
Harmonic	9271.00	-75.0

4.3.4 Conducted Harmonic Emissions (100 kHz Res. BW) Low Channel Plot:

MODULATED CARRIER (100 kHz RES. BW)
LOW CHANNEL

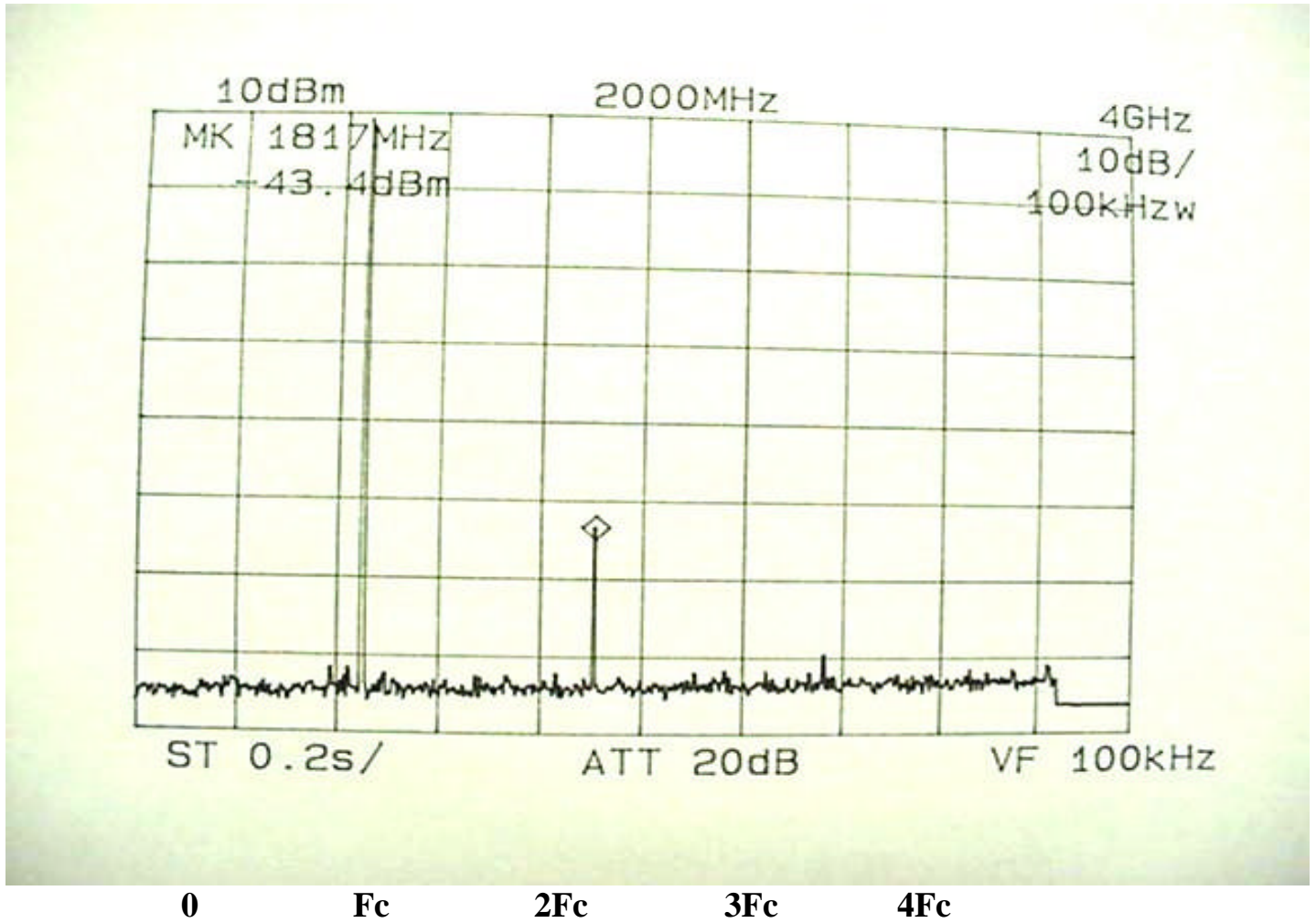

4.3.5 Conducted Harmonic Emissions (100 kHz Res. BW) Mid Channel Plot:

MODULATED CARRIER (100 kHz RES. BW)
MID CHANNEL

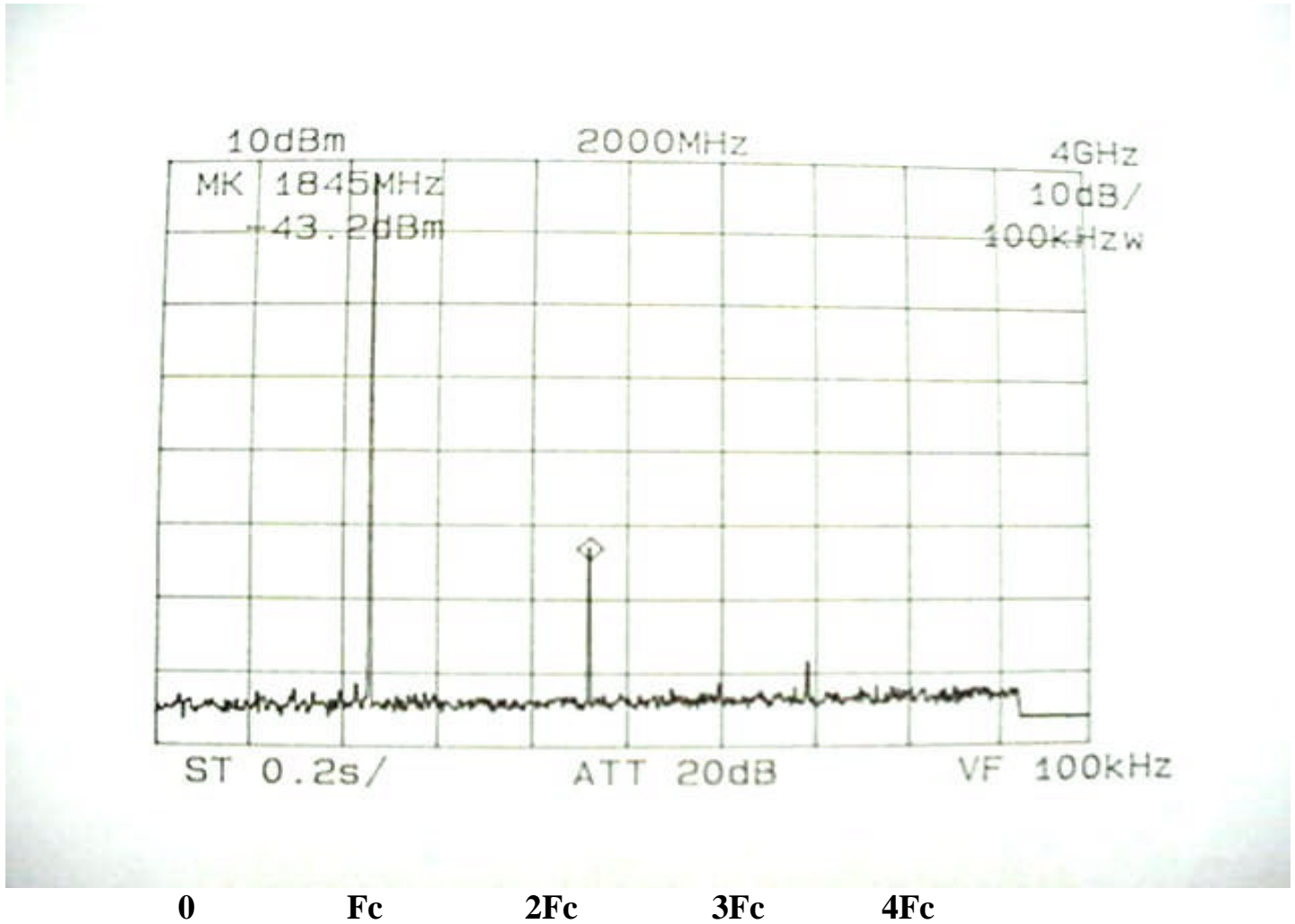

4.3.6 Conducted Harmonic Emissions (100 kHz Res. BW) High Channel Plot:

MODULATED CARRIER (100 kHz RES. BW)
HIGH CHANNEL

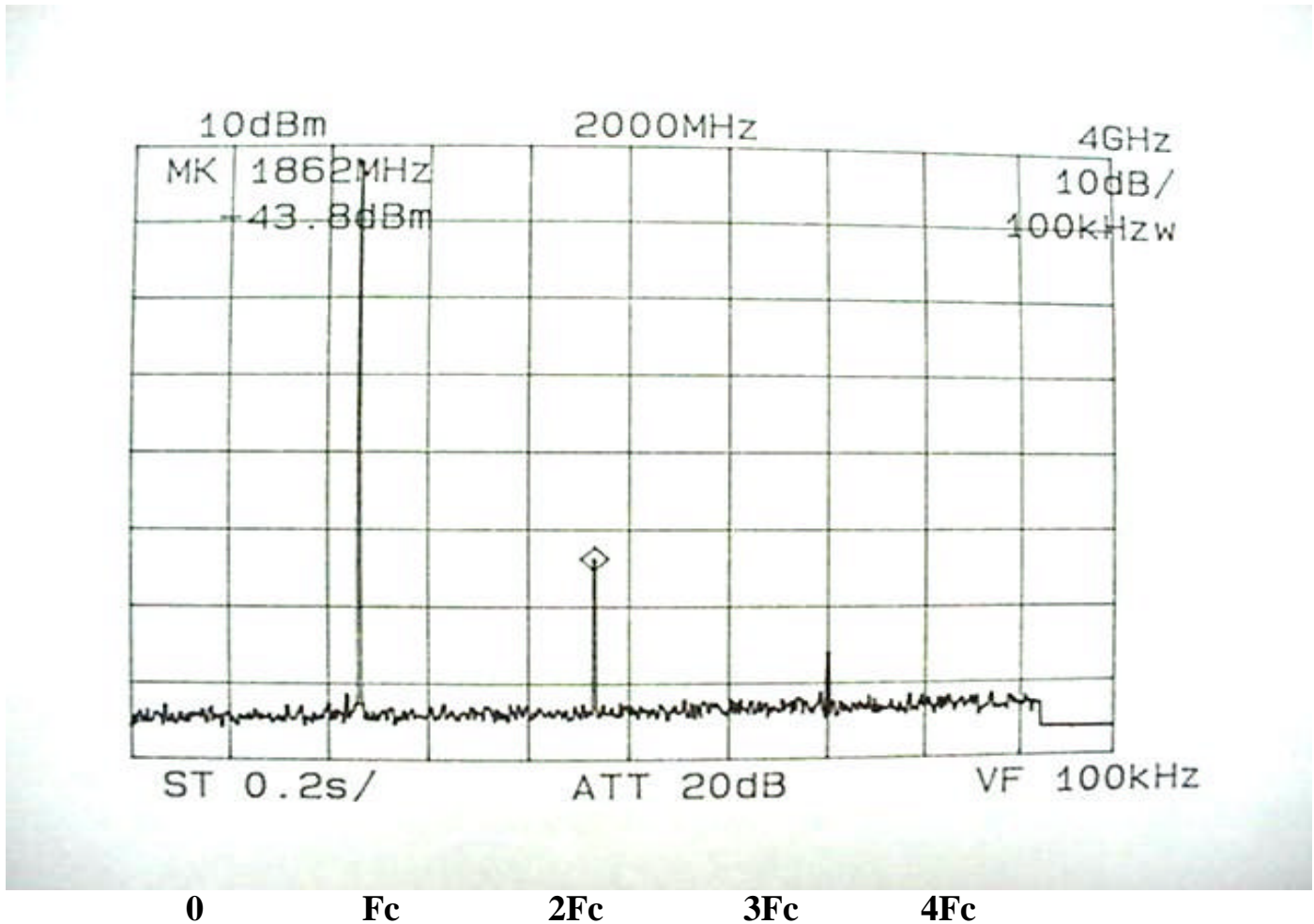

4.4 Conducted Bandedge Emissions Test Results:

MODULATED CARRIER: (100 kHz RES. BW)

4.4.1 Low Channel Conducted Bandedge Emissions Plot:

CONDUCTED BAND EDGE EMISSIONS – MODULATED CARRIER (100 kHz RES. BW)

LOW CHANNEL

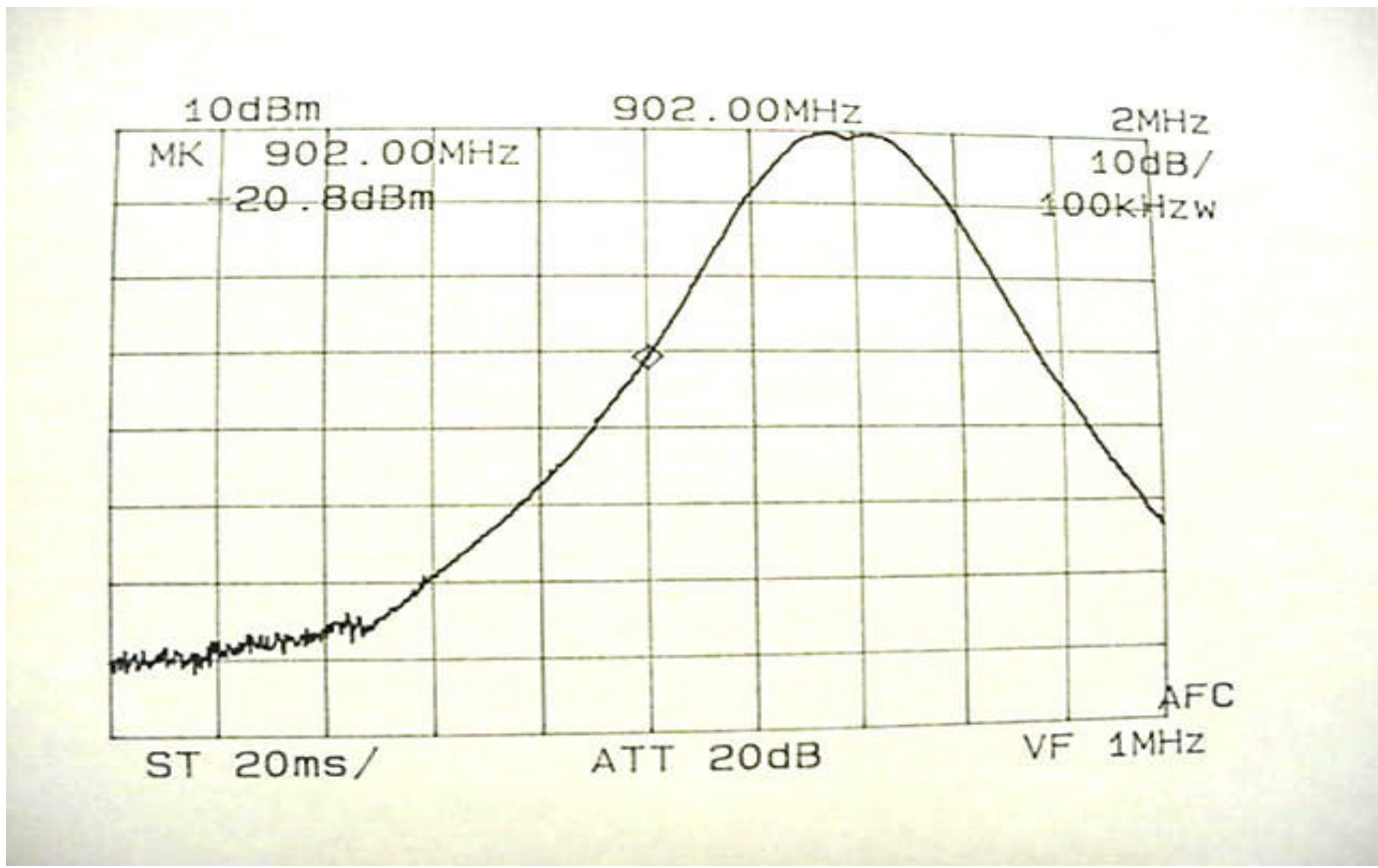

4.4.2 High Channel Conducted Bandedge Emissions Plot:

CONDUCTED BAND EDGE EMISSIONS – MODULATED CARRIER (100 kHz RES. BW)

HIGH CHANNEL

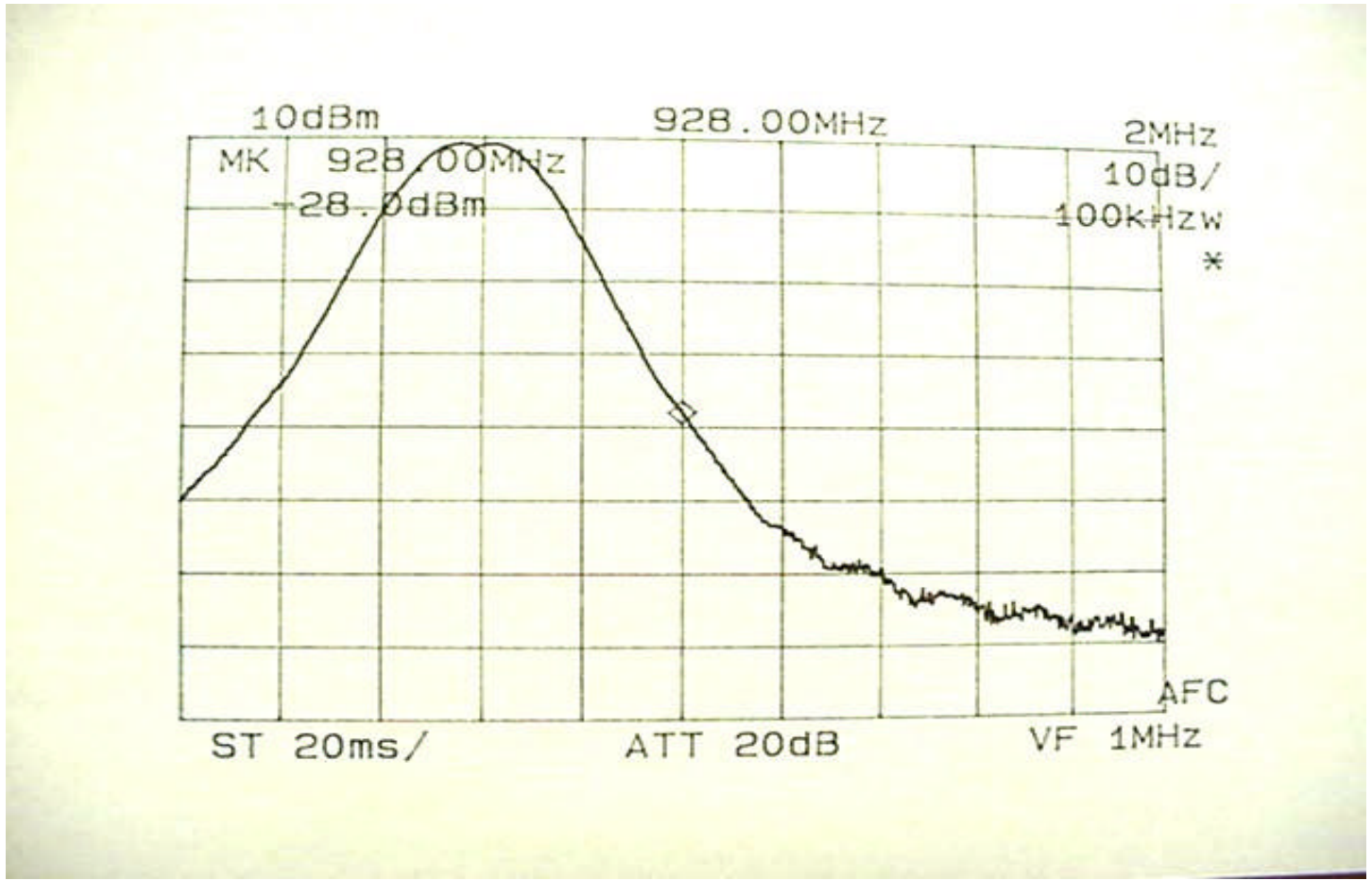

4.5 Channel Occupancy Test Results:

The EUT uses 50 hopping channels with each channel 400 kHz wide selected from a pseudo randomly ordered list. On the average, each channel is used equally. The number of frequency hopping channels was verified by counting the number of channel frequencies. See the following plots.

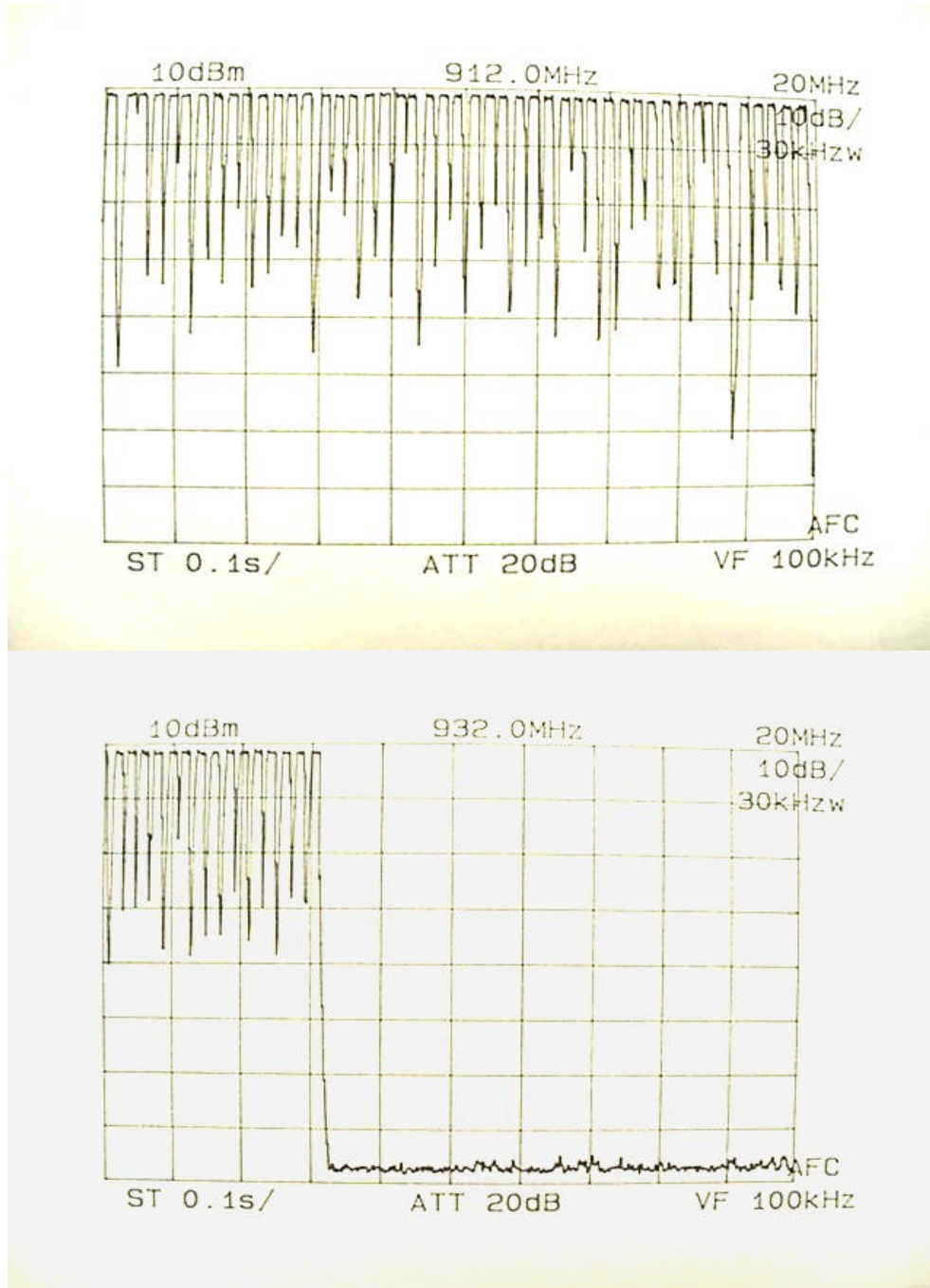

4.6 EUT Average Time of Channel Occupancy and Dwell Time:

The EUT average occupancy time and dwell time was checked for compliance. The selected channel frequency for dwell time measurement was 914.8 MHz with highest available data rate. The channel occupancy time was found to be 26.8 msec. See plot.

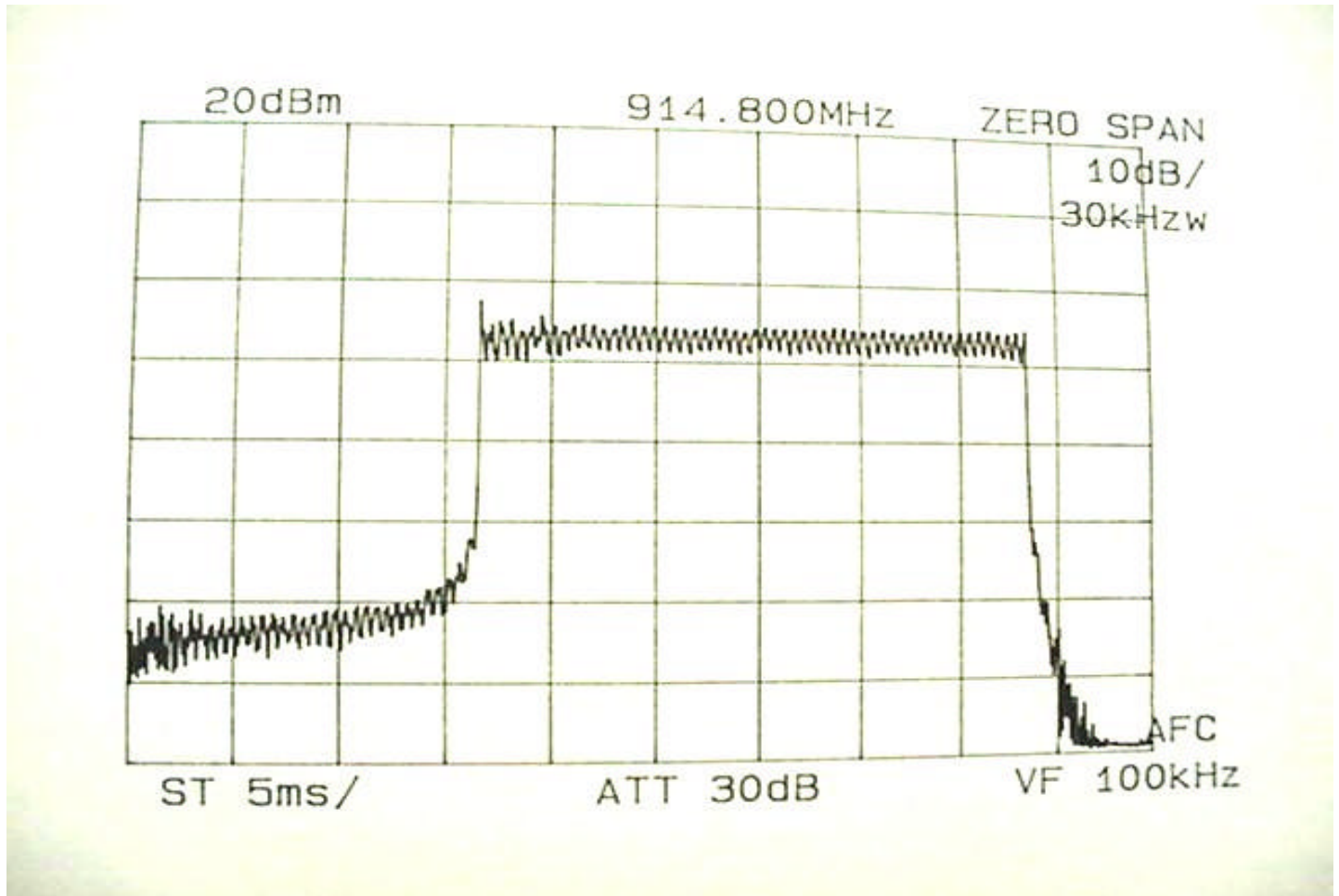

4.7 Hopping Dwell Time:

The EUT channel occupancy time was verified to be 26.8 ms as demonstrated in previous plot. Each frequency is used 7 times on average within a 30 sec period. The average dwell time on any frequency within 30 sec period is $.0268 \text{ sec} \times 7 = 0.188 \text{ sec}$ (less than 0.4 sec). The number of hops on 914.8 MHz was verified at 7 per 30 sec period (see plot). The dwell time was measured by setting the spectrum analyzer to 0 span, RSW/VID = 30 kHz/ 100 kHz. The analyzer was set to 50 sec sweep time for average occupancy time. (see plot)

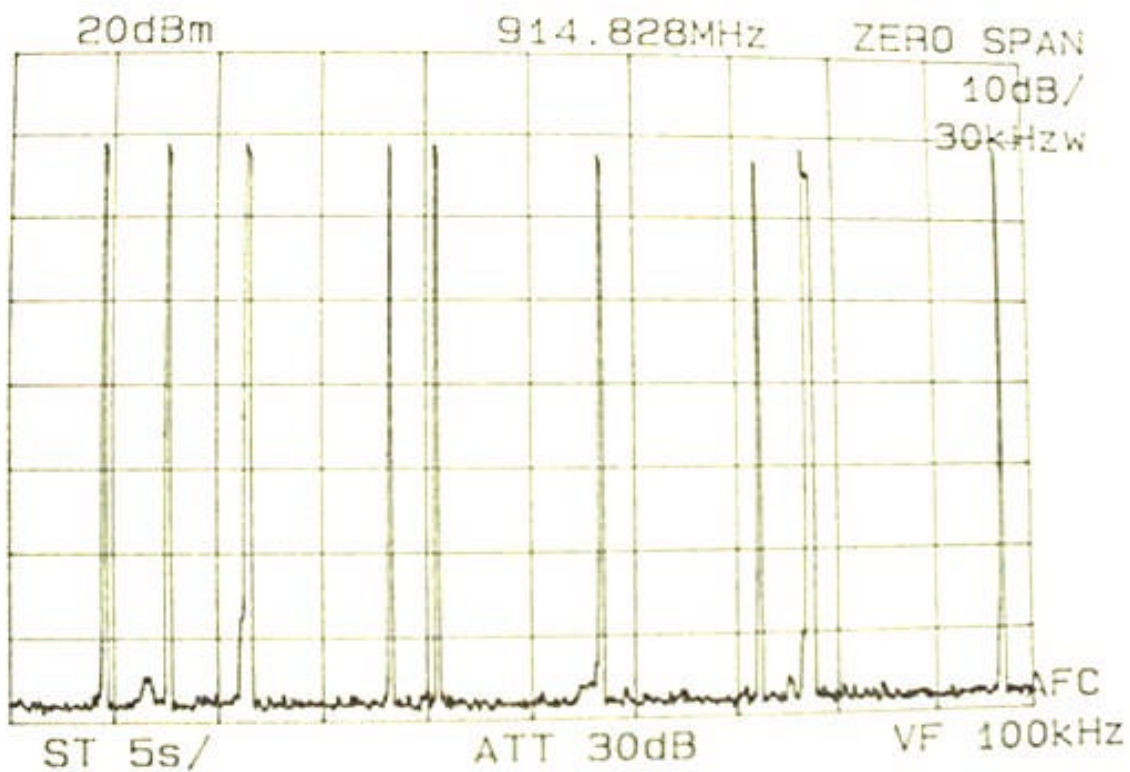

5.0 Test Configuration for Conducted and Radiated Emissions:

The EUT was set up on the center of the test table, in a manner which follows the general guidelines of ANSI C63.4, Section 6 “**General Operating Conditions and Configurations**”.

This is described below:

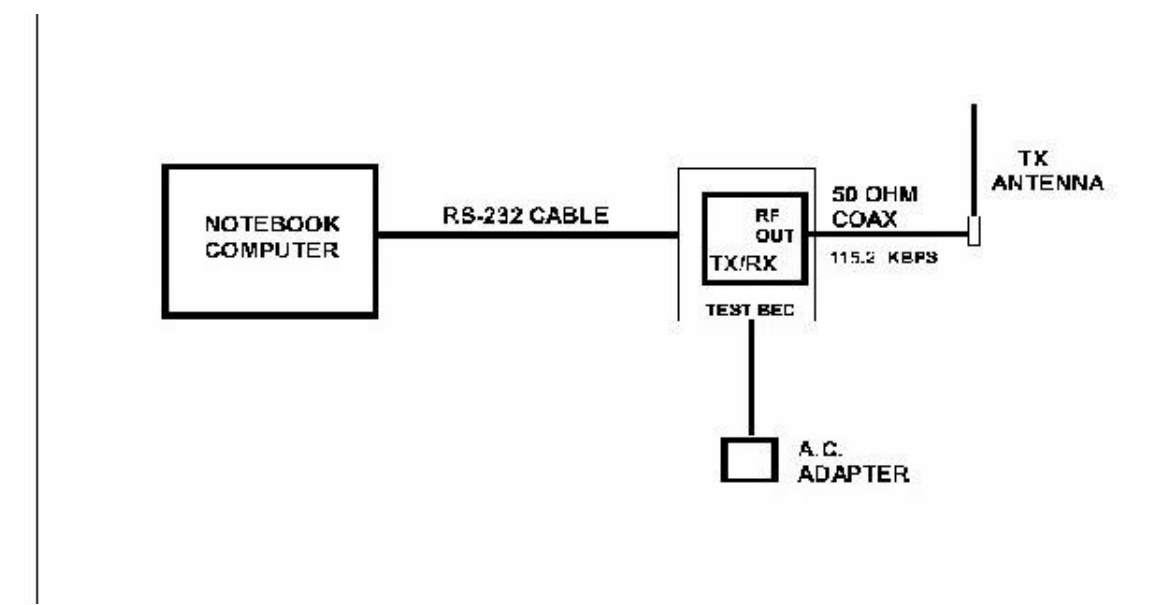

6.0 A.C. Conducted Emissions Scheme:

The EUT is placed on an 80 cm high 1 X 1.5 m non-conductive table. Power to the RF amplifier is provided through a Solar Corporation 50 Ω / 50 μ H Line Impedance Stabilization Network bonded to a 2.2 X 2 meter horizontal ground plane, and a 2.2 X 2 meter vertical ground plane. The LISN has its AC input supplied from a filtered AC power source. A separate LISN provides AC power to the peripheral equipment. I/O cables are moved about to obtain maximum emissions.

The 50 Ω output of the LISN is connected to the input of the spectrum analyzer and emissions in the frequency range of 450 kHz to 30 MHz are searched. The detector function is set to Quasi-Peak and the resolution bandwidth is set at 9 kHz, with all post detector filtering no less than 10 times the resolution bandwidth for final measurements. All emissions within 20 dB of the limit are recorded in the data tables.

6.1 AC Conducted Emissions Data Table

FCC CLASS "B" CONDUCTED EMISSIONS DATA

CLIENT: MICROHARD
EUT: MHX-920E

MODE: TRANSMIT

LINE 1- Quasi-Peak Date:

FREQUENCY MHz	SPEC. Ana dBuV	Calc. Volt uV	FCC LIMIT uV	MARGIN dB	CONDITION
0.47	36.00	63.10	250.00	11.96	PASS
6.20	35.00	56.23	250.00	12.96	PASS
7.20	38.20	81.28	250.00	9.76	PASS
27.50	30.80	34.67	250.00	17.16	PASS

LINE 2- Quasi-Peak

FREQUENCY MHz	SPEC. Ana dBuV	Calc. Volt uV	FCC LIMIT uV	MARGIN dB	CONDITION
0.52	35.60	60.26	250.00	12.36	PASS
4.80	34.60	53.70	250.00	13.36	PASS
6.20	34.80	54.95	250.00	13.16	PASS
23.90	33.40	46.77	250.00	14.56	PASS
28.40	32.00	39.81	250.00	15.96	PASS

TEST ENGINEER:

Brian Hahtalah

7.0 Radiated Emissions Scheme:

The EUT is placed on an 80 cm high 1 X 1.5 meter non-conductive motorized turntable for radiated testing on the 3 meter open area test site. The emissions from the EUT are measured continuously at every azimuth by rotating the turntable. Guided horn and log periodic broadband antennas are mounted on an antenna mast to determine the height of the maximum emissions. The heights of the antennas are varied between 1 and 4 meters. Both the horizontal and vertical field components are measured.

The RF spectrum is searched from 30 MHz to 9.28 GHz.

The output from the antenna is connected to the input of the preamplifier. The pre-amp out is connected to the spectrum analyzer. The detector function is set to PEAK. The resolution bandwidth of the spectrum analyzer is set at 120 kHz for the frequency range of 30-1000 MHz, and 1 MHz for the frequency range of 1-9 GHz. A 10Hz video BW setting is used to average readings above 1 GHz when applicable. All emissions within 20 dB of the limit are recorded in the data tables.

To convert the spectrum analyzer reading into a quantified E-field level to allow comparison with the FCC limits, it is necessary to account for various calibration factors. These factors include cable loss (CL) and antenna factors (AF). The AF/CL in dB/m is algebraically added to the Spectrum Analyzer Voltage in dBμV/m. This level is then compared to the FCC limit.

EXAMPLE

Spectrum Analyzer Voltage:	VdBmV
Composite Factor:	AF/CL dB/m
Electric Field:	E dBmV/m = V dBmV + AF/CL dB/m
Linear Conversion:	E mV/m = Antilog (E dBmV/m /20)

7.1 Yagi Antenna, 902.8 MHz, 100mW Radiated Emissions Data Table

FCC RADIATED EMISSIONS DATA

CLIENT: MICROHARD SYSTEMS
 EUT: MHX-920E
 ANTENNA: YAGI
 FREQ.: 902.8 MHZ
 POWER: 100 mW

3 METER TEST

DATE: 02/17/01

FREQUENCY MHz	POLARITY		SPEC A dBuV	AF/C dB/m	AMP Gain dB	Average Factor dB	Peak E-Field dbuV/m	Average Limit dBuV/m	MARGIN dB	CONDITION
	H	V								
2,708.40	H		42.00	35.00	25.00	0.00	52.00	54.00	2.00	PASS
3,611.20	H		40.00	36.00	25.00	0.00	51.00	54.00	3.00	PASS
4,514.00	H		33.00	39.00	25.00	0.00	47.00	54.00	7.00	PASS
5,416.80		V	29.00	37.00	25.00	0.00	41.00	54.00	13.00	PASS
8,125.20		V	30.00	38.00	25.00	0.00	43.00	54.00	11.00	PASS
9,028.00	H		26.00	39.00	25.00	0.00	40.00	54.00	14.00	PASS

TEST ENGINEER:

Brian Haqhtalab



7.2 Yagi Antenna, 914.7 MHz, 100mW, Radiated Emissions Data Table

FCC RADIATED EMISSIONS DATA

CLIENT: MICROHARD SYSTEMS
 EUT: MHX-920E
 ANTENNA: YAGI
 FREQ.: 914.7 MHz
 POWER: 100 mW

3 METER TEST

DATE: 02/16/01

FREQUENCY MHz	POLARITY		SPEC A dBuV	AF/C dB/m	AMP Gain dB	Average Factor dB	Peak E-Field dbuV/m	Average Limit dBuV/m	MARGIN dB	CONDITION
	H	V								
2,744.10	H		41.00	35.00	25.00	0.00	51.00	54.00	3.00	PASS
3,658.80	H		39.00	36.00	25.00	0.00	50.00	54.00	4.00	PASS
4,573.50	H		33.00	39.00	25.00	0.00	47.00	54.00	7.00	PASS
7,317.60		V	30.00	37.00	25.00	0.00	42.00	54.00	12.00	PASS
8,232.30		V	32.00	38.00	25.00	0.00	45.00	54.00	9.00	PASS
9,147.00	H		27.00	39.00	25.00	0.00	41.00	54.00	13.00	PASS

TEST ENGINEER:

Brian Haghtalab

7.3 Yagi Antenna, 927.1 MHz, 100mW Radiated Emissions Data Table

FCC RADIATED EMISSIONS DATA

CLIENT: MICROHARD SYSTEMS
 EUT: MHX-920E
 ANTENNA: YAGI
 FREQ.: 927.1 MHZ
 POWER: 100 mW

3 METER TEST

DATE: 02/17/01

FREQUENCY MHz	POLARITY		SPEC A dBuV	AF/C dB/m	AMP Gain dB	Average Factor dB	Peak E-Field dbuV/m	Average Limit dBuV/m	MARGIN dB	CONDITION
	H	V								
2,781.30	H		41.00	35.00	25.00	0.00	51.00	54.00	3.00	PASS
3,708.40	H		39.00	36.00	25.00	0.00	50.00	54.00	4.00	PASS
4,635.50	H		36.00	39.00	25.00	0.00	50.00	54.00	4.00	PASS
7,416.80	H		30.00	37.00	25.00	0.00	42.00	54.00	12.00	PASS
8,343.90	H		27.00	38.00	25.00	0.00	40.00	54.00	14.00	PASS

TEST ENGINEER:

Brian Haghtalab



7.4 6 dBi Omni Antenna, 902.8 MHz, 1000mW Radiated Emissions Data Table

FCC RADIATED EMISSIONS DATA

CLIENT: MICROHARD SYSTEMS
 EUT: MHX-920E
 ANTENNA: 6 dBi OMNI
 FREQ.: 902.8 MHZ
 POWER: 1000 mW

3 METER TEST PEAK DETECT DATE: 02/17/01

FREQUENCY MHz	POLARITY		SPEC A dBuV	AF/C dB/m	AMP Gain dB	Average Factor dB	Peak E-Field dbuV/m	Average Limit dBuV/m	MARGIN dB	CONDITION
	H	V								
2,708.40	H		38.00	35.00	25.00	0.00	48.00	54.00	6.00	PASS
3,611.20	H		34.00	36.00	25.00	0.00	45.00	54.00	9.00	PASS
4,514.00	H		30.00	39.00	25.00	0.00	44.00	54.00	10.00	PASS
5,416.80		V	31.00	37.00	25.00	0.00	43.00	54.00	11.00	PASS
8,125.20		V	29.00	38.00	25.00	0.00	42.00	54.00	12.00	PASS
9,028.00	H		24.00	39.00	25.00	0.00	38.00	54.00	16.00	PASS

TEST ENGINEER:

Brian Haghtalab



7.5 6 dBi Omni Antenna, 914.7 MHz, 1000mW Radiated Emissions Data Table

FCC RADIATED EMISSIONS DATA

CLIENT: MICROHARD SYSTEMS
 EUT: MHX-920E
 ANTENNA: 6dBi OMNI
 FREQ.: 914.7 MHZ
 POWER: 1000 mW

3 METER TEST PEAK DETECT DATE: 02/16/01

FREQUENCY MHz	POLARITY		SPEC A dBuV	AF/C dB/m	AMP Gain dB	Average Factor dB	Peak E-Field dbuV/m	Average Limit dBuV/m	MARGIN dB	CONDITION
	H	V								
2,744.10	H		37.00	35.00	25.00	0.00	47.00	54.00	7.00	PASS
3,658.80	H		35.00	36.00	25.00	0.00	46.00	54.00	8.00	PASS
4,573.50	H		35.00	39.00	25.00	0.00	49.00	54.00	5.00	PASS
7,317.60		V	30.00	37.00	25.00	0.00	42.00	54.00	12.00	PASS
8,232.30		V	29.00	38.00	25.00	0.00	42.00	54.00	12.00	PASS
9,147.00	H		24.00	39.00	25.00	0.00	38.00	54.00	16.00	PASS

TEST ENGINEER:

Brian Haghtalab



7.6 6 dBi Omni Antenna, 927.1 MHz, 1000mW Radiated Emissions Data Table

FCC RADIATED EMISSIONS DATA

CLIENT: MICROHARD SYSTEMS
 EUT: MHX-920E
 ANTENNA: 6dBi OMNI
 FREQ.: 927.1 MHZ
 POWER: 1000 mW

3 METER TEST PEAK DETECT DATE: 02/16/01

FREQUENCY MHz	POLARITY		SPEC A dBuV	AF/C dB/m	AMP Gain dB	Average Factor dB	Peak E-Field dbuV/m	Average Limit dBuV/m	MARGIN dB	CONDITION
	H	V								
2,781.30	H		37.00	35.00	25.00	0.00	47.00	54.00	7.00	PASS
3,708.40	H		36.00	36.00	25.00	0.00	47.00	54.00	7.00	PASS
4,635.50	H		31.00	39.00	25.00	0.00	45.00	54.00	9.00	PASS
7,416.80	H		32.00	37.00	25.00	0.00	44.00	54.00	10.00	PASS
8,343.90	H		27.00	38.00	25.00	0.00	40.00	54.00	14.00	PASS

TEST ENGINEER:

Brian Haqhtalab



7.7 Receiver, 915 MHz Radiated Emissions Data Table

FCC CLASS "B" RADIATED EMISSIONS DATA

CLIENT: Microhard
EUT: MHX-920E

MODE: Receive

3 METER TEST Quasi-Peak

DATE:

FREQUENCY MHz	POLARITY		SPEC A dBuV	AF/CL dB/m	E-FIELD dBuV/m	E-FIELD uV/m	LIMIT uV/m	MARGIN dB	CONDITION
	HORIZ.	VERT.							
36.93		V	22.00	15.67	37.67	76.47	100.00	2.33	PASS
49.21	H		24.00	12.05	36.05	63.46	100.00	3.95	PASS
73.90	H		30.00	6.39	36.39	65.99	100.00	3.61	PASS
175.40	H		23.00	16.19	39.19	91.10	150.00	4.33	PASS
196.70	H		21.00	17.33	38.33	82.51	150.00	5.19	PASS
208.95	H		22.00	17.50	39.50	94.41	150.00	4.02	PASS
233.60		V	23.00	18.64	41.64	120.78	200.00	4.38	PASS
245.80		V	20.00	18.93	38.93	88.41	200.00	7.09	PASS
270.40	H		22.00	20.34	42.34	130.92	200.00	3.68	PASS
344.10		V	25.00	14.80	39.80	97.72	200.00	6.22	PASS
393.30		V	22.00	15.90	37.90	78.52	200.00	8.12	PASS
553.10	H		23.00	19.00	42.00	125.89	200.00	4.02	PASS
614.50		V	20.00	19.60	39.60	95.50	200.00	6.42	PASS

TEST ENGINEER:



Brian Hashtalah

8.0 RF Exposure Statement:

Notice in Installation Manual:

FCC Radiation Exposure Statement

This equipment complies with FCC radiation exposure limits set forth for an uncontrolled environment, when installed as directed. This equipment should be installed and operated with fix-mounted antennas that are installed with a minimum of 2 meters of separation distance between the antenna and all persons' body during normal operation.

RF Exposure Calculations:

The following information provides the **minimum** separation distance for the highest gain antenna provided with the EUT, as calculated from **FCC OET 65 Appendix B, Table 1B** Guidelines for General Population/Uncontrolled Exposure. This calculation is based on the highest EIRP possible from the system, considering maximum power and antenna gain, and considering a 0.6 mW/cm² uncontrolled exposure limit. The Friss formula used was:

$$S = (P_o * G) / (4 * \pi * r^2) \quad \text{or} \quad r = \sqrt{(P_o * G) / (4 * \pi * S)}$$

Where **S = 0.6 mW/cm² for 902 MHz (902 / 1500)**

Where **P_o = 100 mW Peak for Yagi antennas, and 1000 mW for Omni Antennas**

Where **G= Isotropic antenna gain (numeric)**

Where **r= Minimum Safe Distance from antenna (cm)**

For: 12 dB Yagi Antenna r = 14 cm

2.5dB Omni Antenna r = 15 cm

6 dB Omni Antenna r = 23 cm

RF Exposure Table For Antennas Used With This Equipment

Antenna Type	Gain (dBi)	Numeric Gain	Channel	Peak Output Power (mW)	Calculated Distance (cm)	Minimum RF Exposure Separation Distance (cm)
Yagi	12	16	1	100	14	20
Yagi	11	13	1	100	13	20
Omni	6	4	1	1000	23	23
Omni	2.5	1.8	1	1000	16	20

TABLE 1 – EUT ACCESSORIES

Authorized Antennas

Antenna Type	Gain	Make	Model
Yagi	12 dBi	Antenex	Y89612
Yagi	11 dBi	Bluewave	BW9411Y-2
Omni	6 dBi	Antenex	FG9026
Omni	2.5 dBi	Microhard	Rubber Ducky

TABLE 2
SUPPORT EQUIPMENT

MANUFACTURER	FCC ID #	SERIAL #
Host PC - Pakon Pentium III Tower PC		
Microhard OEM Testing Platform		

**TABLE 3
 MEASUREMENT EQUIPMENT USED**

The following equipment is used to perform measurements:

EQUIPMENT	SERIAL #
HP 434A RF Peak Power Meter	1362016
EMCO Model 3110 Biconical Antenna	1619
Antenna Research MWH-1825B Horn Antenna	1005
EMCO Model 3115 Ridged Horn Antenna	3007
HP 8348A Pre-Amplifier	197-2564A
Solar 8012-50-R-24-BNC LISN	924867
Bird 8306-300-N-30dB Attenuator	29198391515
HP 14IT w/8555A Spectrum Analyzer	6-95-1124
4 Meter Antenna Mast	
Motorized Turntable	
Heliac FSJ1-50A ¼" Superflex Coax Cable	
4 Meter Antenna Mast	

EXHIBIT 1.1
AC CONDUCTED EMISSIONS PHOTOGRAPHS





EXHIBIT 1.2
RADIATED EMISSIONS PHOTOGRAPHS



**EXHIBIT 2
SCHEMATICS**

EXHIBIT 3
USER'S MANUAL