

CIRCUIT DESCRIPTION

1. HANDSET

1.1 RECEPTION

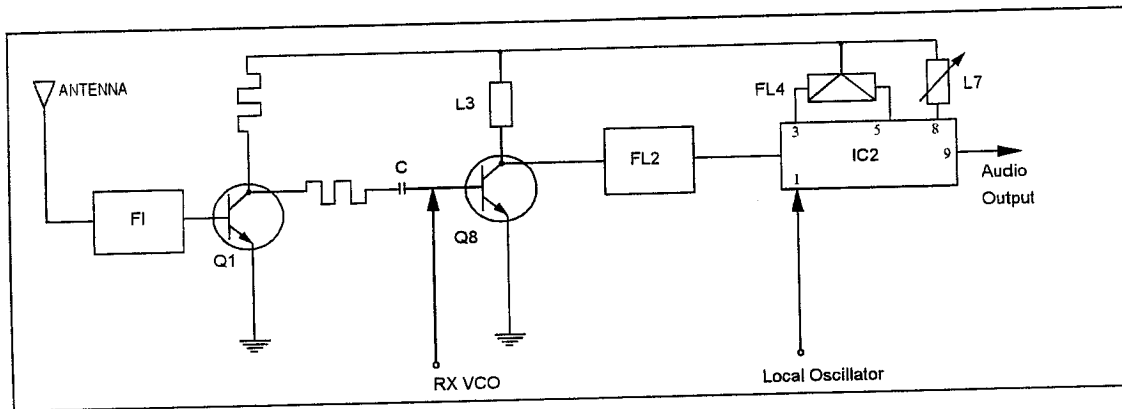

Figure 1

As shown in figure 1, the received signal from the base unit passes through 927 MHz Filter and amplified by RF Amplifier (Q8). The amplified input signal is mixed with RX VCO (Q11, Q7, L6, D1) signal.

The VCO oscillation is controlled by error signals from PLL IC3 pin no. 10. The channel information to PLL IC is provided by Microprocessor IC (IC100) pin nos. 11,12 and 13. (Serial data outputs).

The Mixer output from Q9 passes through 10.7 MHz Ceramic Filter (F3) and enters to FM Demodulator IC1 pin no. 16. This signal mixes with 11.15 MHz signal from PLL IC3 pin no. 11, which is connected to IC1 pin no.1. The mixed signal is filtered by 450 KHz Filter (F4).

1.2 RINGER OUTPUT

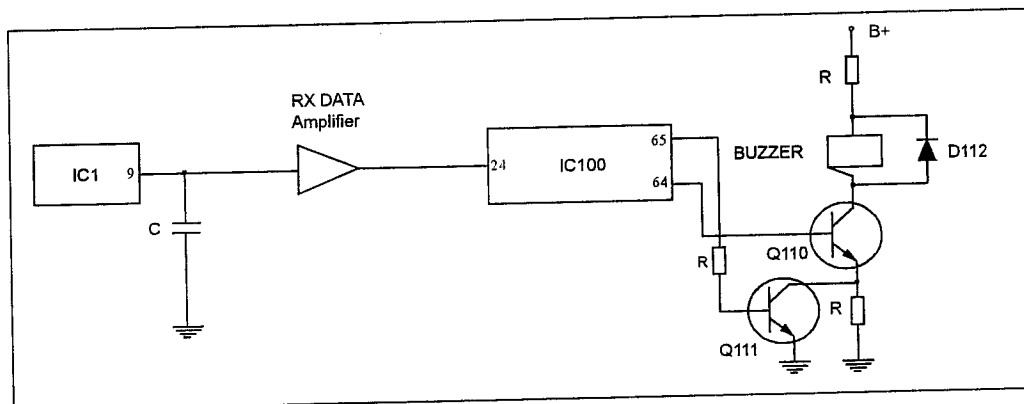

Figure 2

After detection of ring signal, the base unit will transmit the data code signal including security code to handset.

As shown in figure 2, the demodulated ring signal from pin no. 9 of FM Demodulator IC1 is fed to low pass filter and amplified by RX Data Amplifier and its output is connected to RX Data port of Microprocessor IC (IC100).

The ring signal output from pin no. 65,64 of Microprocessor IC (IC100) goes to buzzer driver Q110 and Q111 to activate the buzzer.

1.3 VOICE OUTPUT

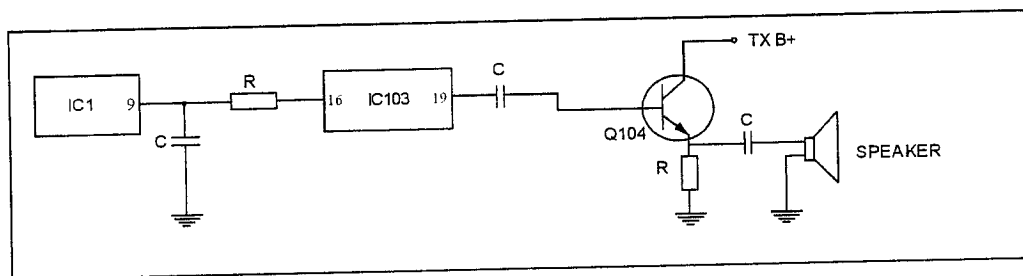

Figure 3

The demodulated signal, resulting from Double Super Heterodyne system, which appears at output pin no. 9 of IC1 is connected to pin no. 16 Expander input of Compaider IC (IC103) for expansion. The expanded audio output from IC103 pin no. 19 is finally amplified by Q104 and A.C. coupled to the receiver unit with Hearing Aid Compatibility (HAC).

1.4 DATA TRANSMISSION

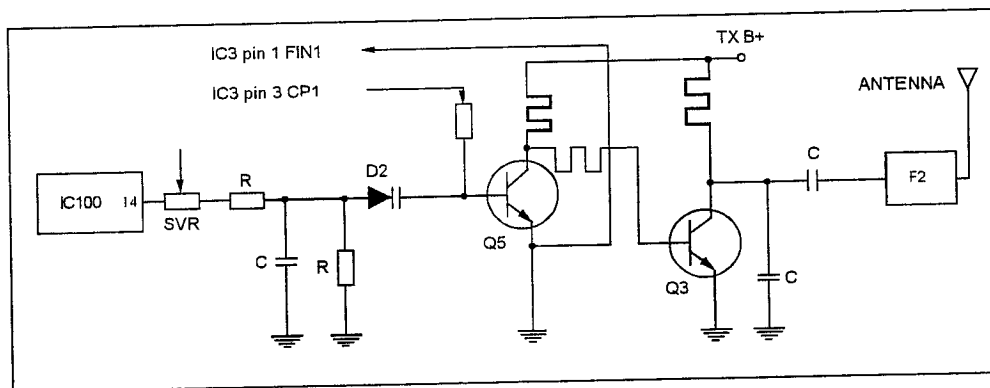

Figure 4

As shown in figure 4, the TX data code output including security code from IC1 pin no. 14 is connected to TX VCO for modulation. The data code signal is modulated with the carrier frequency generated by the RFoscillator (Q5). The oscillator frequency is controlled by the error signal from pin no.3 of PLL IC (IC3). The modulated signal is amplified by RF amplifier stage (Q3) and then passes through 927MHz filter stage (F2). The FM modulated signal is radiated by the handset Rubberized Antenna.

1.5 VOICE TRANSMISSION

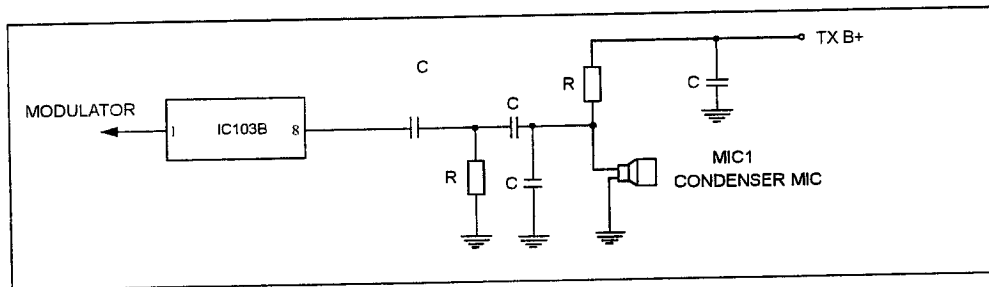

Figure 5

Voice signal from condenser mic is coupled to pin no. 8 of Compaander IC (IC103B). The voice signal is compressed by IC103B and then connected to TX VCO stage for modulation.

1.6 RECEIVER POWER CONTROL

- When at STANDBY mode and RING ON mode the handset has 50 ms power on and 800ms power off on receiver section.
- When at STANDBY mode and SAVE ON mode, the handset have no power on receiver section.
- The power saving is controlled by Microprocessor IC (IC100) pin no. 27 (RX power control) and Q100.

1.7 TRANSMITTER POWER CONTROL

- When at TALK mode, the handset transmitter should be working.
- The transmitter power is controlled by Microprocessor IC (IC100) pin no. 28 (TX power control) and Q101.

1.8 BATTERY LOW DETECTOR

- When the battery voltage goes down until 3.3 to 0.1 Vdc, the LED1 will flash with warning sound "Bi, Bi".

1.9 BATTERY CHARGING

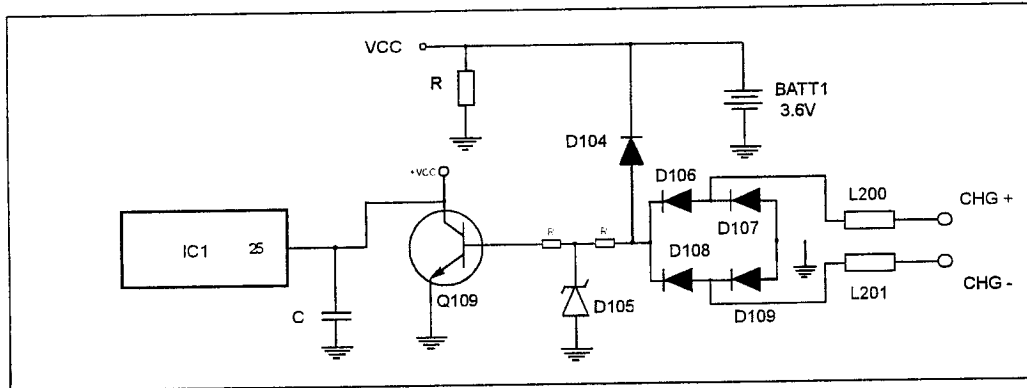

Figure 6

- When the handset is placed on the base unit cradle, the battery will be charging and will be detected by Microprocessor IC (IC100) pin no.25.
- Microprocessor IC will exchange security code randomly.

1.10 SQUELCH

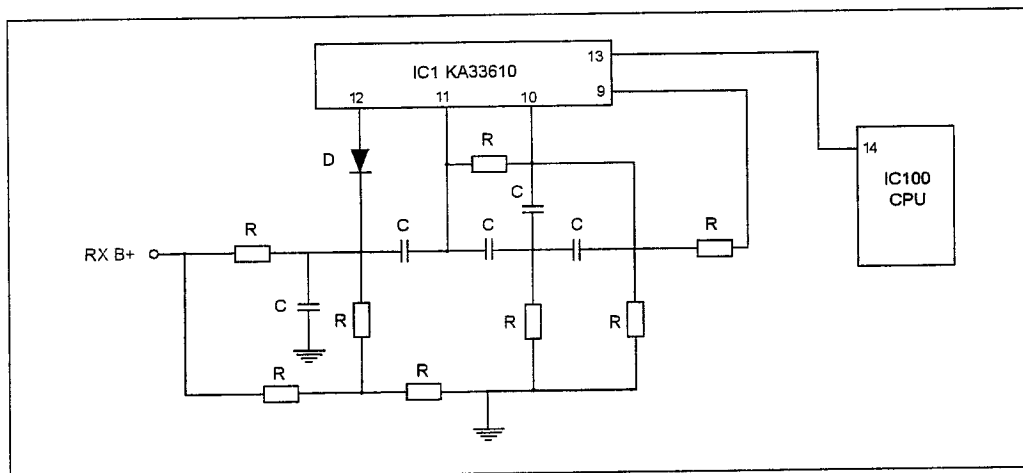

Figure 7

As shown in figure 7, the audio output (noise output) from FM Demodulator IC (IC1) pin no.9 goes to pin no. 10 (Noise filter input) and the output from pin no. 11 will enter to pin no. 12 to activate the squelch control of IC1. The output from pin no. 11 is connected to the Microprocessor IC (IC100) for RSSI Detection.

NOTE:

- When the handset is far away from the base unit, squelch circuit of IC1 operates and pin no. 13 of IC1 goes 'HI'. This will be detected by Microprocessor and after 10 seconds, it goes to standby mode.

2. BASE UNIT

2.1 RECEPTION

Base receiver circuit is similar to handset receiver circuit description as shown in figure 1. The difference with section 1.1 are local frequency and receiving frequency as describe below.

The received signal from the handset unit passes through 927 MHz filter and amplified by RF RF Amplifier (Q8). The amplified signal is mixed with RX VCO (Q11, Q7, L6, D1).

The mixer output from Q9 passes through 10.7 MHz filter and enters to FM Demodulator IC (IC1) pin no. 16. This signal is mixed with 11.15 MHz signal from PLL IC (IC3) pin no.9, which is connected to IC1 pin no. 1. The mixed signal is filtered by 450 KHz Filter (F4).

2.2 DATA INPUT

The demodulated data code from FM Demodulator IC (IC1) pin no. 9 is fed to Lowpass filter and its output is connected to code input of Microprocessor IC (IC200).

2.3 AUDIO OUTPUT

As shown in figure 8, the demodulated signal which appears at output pin of FM Demodulator IC (IC1) pin no. 9 is sent through lowpass filter to Compander IC (IC100A) pin no. 16 (Expander input) for expansion. The expanded audio signal output from IC100A pin no. 19 is coupled to Buffer Amplifier (Q202,Q201) during the CONVERSATION mode. The audio is sent to telephone line via Hybrid X'former (HYB1).

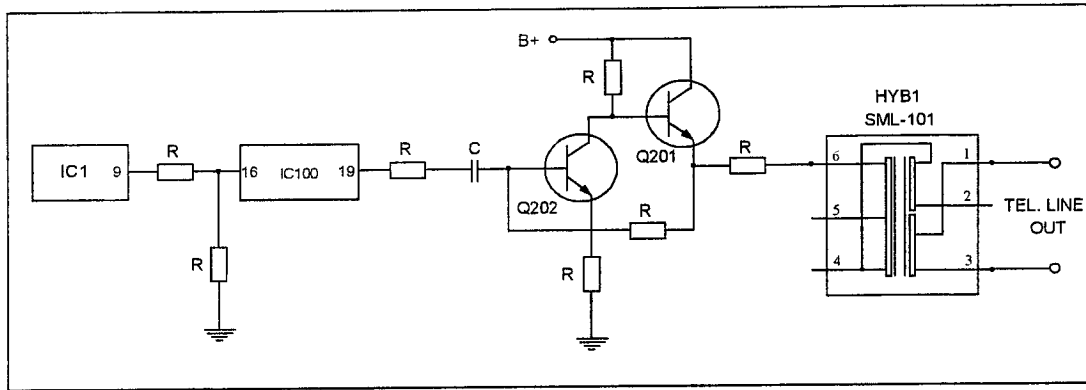

Figure 8

2.4 DATA TRANSMISSION

Refer to figure 4., the difference is that the TX Data is transmitted from pin 10 of Microprocessor IC (IC200).

2.5 VOICE TRANSMISSION

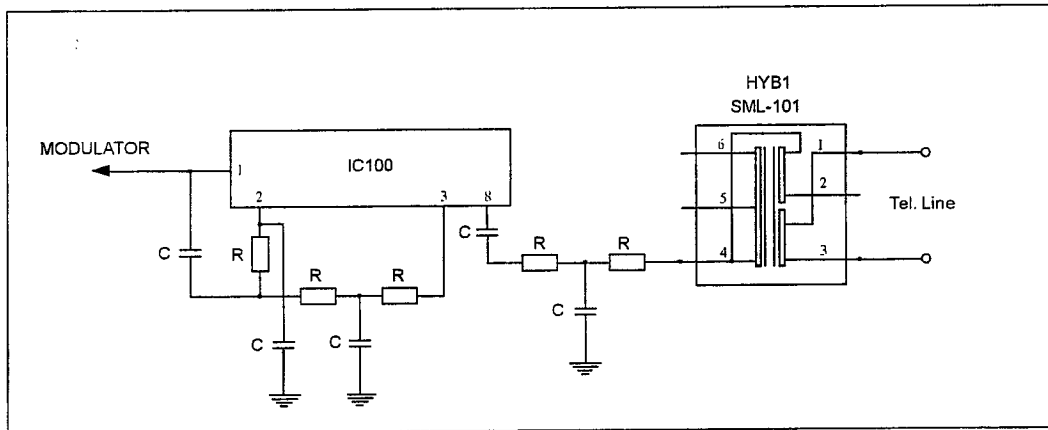

Figure 9

The audio signal receiving from telephone line is input to Componder IC (IC100B) pin no. 8 for compression. The compressed audio signal from pin no.1of IC100B is connected to TX VCO for modulation. The signal is modulated with the carrier frequency of the oscillator (Q5), the oscillator frequency is controlled by the error signal from pin 3 of PLL IC. The modulated signal is amplified by RF Amplifier stage (Q3) and then passes through 903 MHz filter stage (F2). The FM modulated signal is radiated by the base unit antenna.

2.6 DTMF OUT

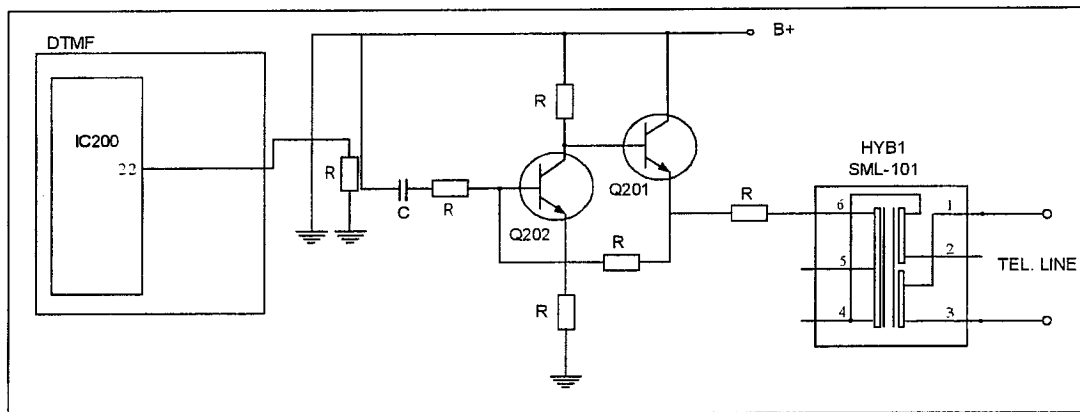

Figure 10

DTMF dialing is generated in pin no. 22 of Microprocessor IC (IC200) .

2.7 TRANSMITTER POWER CONTROL

Transmit power is controlled by IC200 pin 5 and Q100 .

2.8 RINGER DETECT

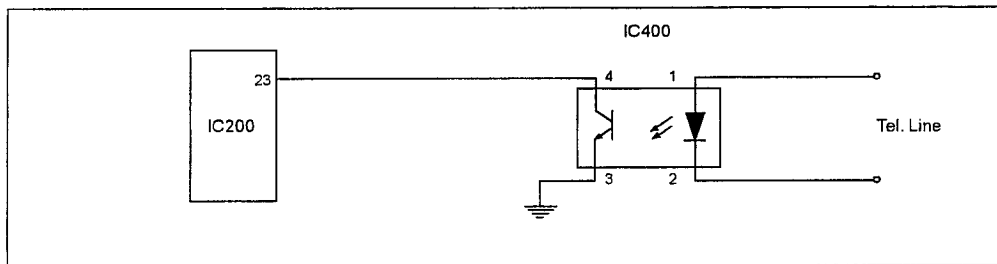

Figure 11

The ring signal from the telephone line is detected by Photocoupler (IC400) and the output from IC400 will be coupled to Microprocessor IC (IC200) pin no. 23. After detection of ring signal, the microprocessor will send the data code to handset.

2.9 PULSE DIAL

During pulse dialing, IC200 CPU pin 224 will be sending pulse dial signal to Relay trigger (Q203) then goes to telephone line.

2.10 CHARGE DETECT

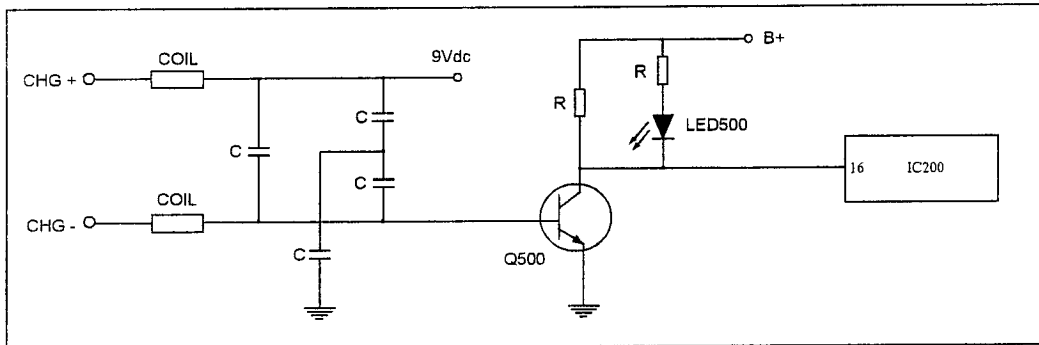

Figure 12

When the handset is on cradle, Q500 is activated and Microprocessor IC (IC200) pin 16 will detect the charging then it will exchange security code randomly.

2.11 SQUELCH

Refer to section 1.10. Squelch operation is same as handset as shown in figure 7.

2.12 PAGE FUNCTION

The Microprocessor IC (IC200) will detect page signal when IC200 pin no. 17 goes low (press SW500), IC200 will transmit paging signal from pin no. 10 (TX Data port).

2.13 RESET

When handset is place on cradle (charge) or insert the power plug into the socket, Base will reset automatically.

40 CHANNEL - AUTOMATIC CHANNEL SELECTION MECHANISM
MODEL: MH9919

During the activation of Talk, the Handset receiver scans for free channel from its last linked receiver channel (about 50ms per channel). Once a free channel is found, the Handset transmits the Talk instruction to Base together with the receiver's free channel information for the Base to use this free channel as the Transmit channel.

Likewise, the Base receiver continuously scans each channel (25ms per channel) and stores all free channels into its memory. Once the Base receiver received the instruction from its Handset, it will stop from scanning and transmits its acknowledgement data with the Base receiver free channel information. When the Handset receives this Base free channel information, it will transmit the link command to Base and both will link on the clearest channel. The Handset and Base scan and find their receiver's clearest channel separately. If all transmit channels of Handset and Base are occupied (all busy), Handset and Base will link on the default channel (Channel 20).

BASE			HANDSET		BASE			HANDSET	
CH	TX	RX	TX	RX	CH	TX	RX	TX	RX
1	902.250	926.250	926.250	902.250	21	903.000	927.000	927.000	903.000
2	902.287	926.287	926.287	902.287	22	903.037	927.037	927.037	903.037
3	902.325	926.325	926.325	902.325	23	903.075	927.075	927.075	903.075
4	902.362	926.362	926.362	902.362	24	903.112	927.112	927.112	903.112
5	902.400	926.400	926.400	902.400	25	903.150	927.150	927.150	903.150
6	902.437	926.437	926.437	902.437	26	903.187	927.187	927.187	903.187
7	902.475	926.475	926.475	902.475	27	903.225	927.225	927.225	903.225
8	902.512	926.512	926.512	902.512	28	903.262	927.262	927.262	903.262
9	902.550	926.550	926.550	902.550	29	903.300	927.300	927.300	903.300
10	902.587	926.587	926.587	902.587	30	903.337	927.337	927.337	903.337
11	902.625	926.625	926.625	902.625	31	903.375	927.375	927.375	903.375
12	902.662	926.662	926.662	902.662	32	903.412	927.412	927.412	903.412
13	902.700	926.700	926.700	902.700	33	903.450	927.450	927.450	903.450
14	902.737	926.737	926.737	902.737	34	903.487	927.487	927.487	903.487
15	902.775	926.775	926.775	902.775	35	903.525	927.525	927.525	903.525
16	902.812	926.812	926.812	902.812	36	903.562	927.562	927.562	903.562
17	902.850	926.850	926.850	902.850	37	903.600	927.600	927.600	903.600
18	902.887	926.887	926.887	902.887	38	903.637	927.637	927.637	903.637
19	902.925	926.925	926.925	902.925	39	903.675	927.675	927.675	903.675
20	902.962	926.962	926.962	902.962	40	903.712	927.712	927.712	903.712