

*Model MH9012*

**40 CHANNEL - AUTOMATIC CHANNEL SELECTION MECHANISM**  
**MODEL: MH9011/MH9012**

During the activation of Talk, the Handset receiver scans for free channel from its last linked receiver channel (about 50ms per channel). Once a free channel is found, the Handset transmits the Talk instruction to Base together with the receiver's free channel information for the Base to use this free channel as the Transmit channel.

Likewise, the Base receiver continuously scans each channel (25ms per channel) and stores all free channels into its memory. Once the Base receiver received the instruction from its Handset, it will stop from scanning and transmits its acknowledgement data with the Base receiver free channel information. When the Handset receives this Base free channel information, it will transmit the link command to Base and both will link on the clearest channel. The Handset and Base scan and find their receiver's clearest channel separately. If all transmit channels of Handset and Base are occupied (all busy), Handset and Base will link on the default channel (Channel 20).

BASE			HANDSET		BASE			HANDSET	
CH	TX	RX	TX	RX	CH	TX	RX	TX	RX
1	902.121	926.117	926.117	902.121	21	902.722	926.717	926.717	902.722
2	902.152	926.147	926.147	902.152	22	902.752	926.747	926.744	902.752
3	902.182	926.177	926.177	902.182	23	902.782	926.777	926.777	902.782
4	902.212	926.207	926.207	902.212	24	902.812	926.807	926.807	902.812
5	902.242	926.237	926.237	902.242	25	902.842	926.837	926.837	902.842
6	902.272	926.267	926.267	902.272	26	902.872	926.867	926.867	902.872
7	902.302	926.297	926.297	902.302	27	902.902	926.897	926.897	902.902
8	902.332	926.327	926.327	902.332	28	902.932	926.927	926.927	902.932
9	902.362	926.357	926.357	902.362	29	902.962	926.957	926.957	902.962
10	902.392	926.387	926.387	902.392	30	902.992	926.987	926.987	902.992
11	902.422	926.417	926.417	902.422	31	903.022	927.017	927.017	903.022
12	902.452	926.447	926.447	902.452	32	903.052	927.047	927.047	903.052
13	902.482	926.477	926.477	902.482	33	903.082	927.077	927.077	903.082
14	902.512	926.507	926.507	902.512	34	903.112	927.107	927.107	903.112
15	902.542	926.537	926.537	902.542	35	903.142	927.137	927.137	903.142
16	902.572	926.567	926.567	902.572	36	903.172	927.167	927.167	903.172
17	902.602	926.597	926.597	902.602	37	903.202	927.197	927.197	903.202
18	902.632	926.627	926.627	902.632	38	903.232	927.227	927.227	903.232
19	902.662	926.657	926.657	902.662	39	903.262	927.258	927.258	903.262
20	902.692	926.687	926.687	902.692	40	903.292	927.288	927.288	903.292

MH9012

CIRCUIT DESCRIPTION

1. HANDSET

1.1 RECEPTION

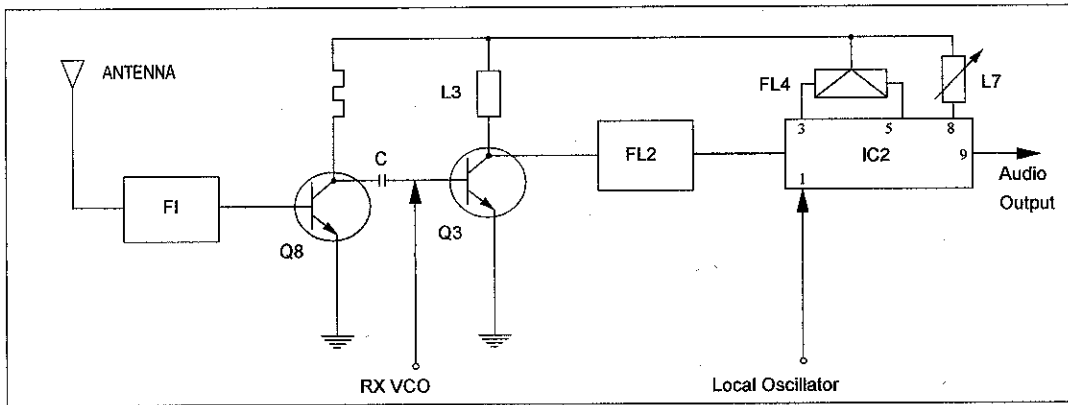

Figure 1

As shown in figure 1, the received signal from the base unit passes through 927 MHz Filter and amplified by RF Amplifier (Q8). The amplified input signal is mixed with RX VCO (Q4,L1,D1) signal.

The VCO oscillation is controlled by error signals from PLL IC pin no. 10. The channel information to PLL IC is provided by Microprocessor IC (IC1) pin nos. 25, 26 and 30. (Serial data outputs).

The Mixer output from Q3 passes through 10.7 MHz Ceramic Filter (FL2) and enters to FM Demodulator IC pin no. 16. This signal mixes with 11.150 MHz signal from PLL IC pin no. 11, which is connected to IC2 pin no.1. The mixed signal is filtered by 450 KHz Filter (FL4).

1.2 RINGER OUTPUT

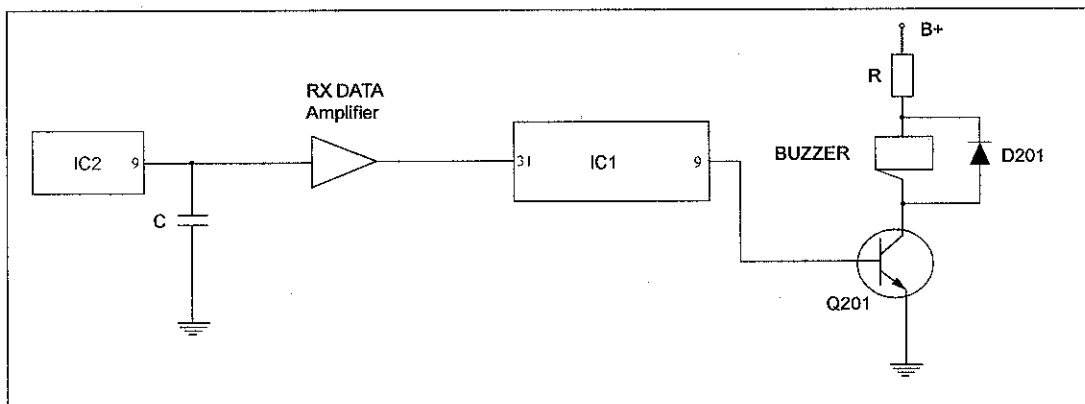

Figure 2

MH9012

After detection of ring signal, the base unit will transmit the data code signal including security code to handset.

As shown in figure 2, the demodulated ring signal from pin no. 9 of FM Demodulator IC2 is fed to low pass filter and amplified by RX Data Amplifier and its output is connected to RX Data port of Microprocessor IC (IC1).

The ring signal output from pin no. 9 of Microprocessor IC (IC1) goes to buzzer driver Q201 to activate the buzzer.

### 1.3 VOICE OUTPUT

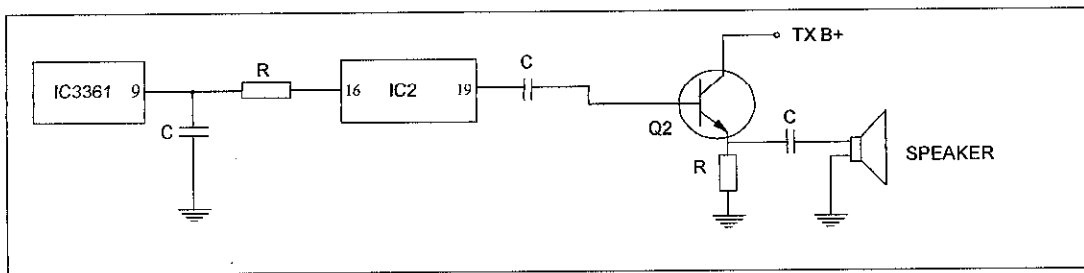

Figure 3

The demodulated signal, resulting from Double Super Heterodyne system, which appears at output pin no. 9 of IC2 is connected to pin no. 16 Expander input of Compander IC (IC2A) for expansion. The expanded audio output from IC2A pin no. 19 is finally amplified by Q2 and A.C. coupled to the receiver unit with Hearing Aid Compatibility (HAC).

### 1.4 DATA TRANSMISSION

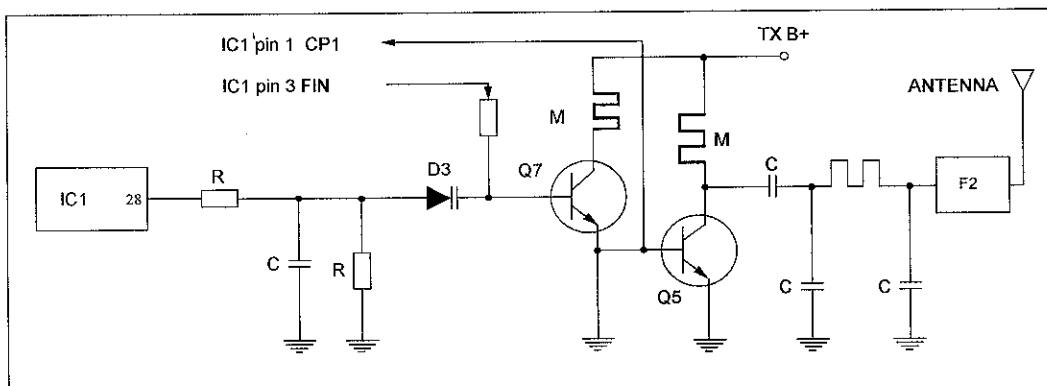

Figure 4

MH9012

As shown in figure 4, the TX data code output including security code from IC1 pin no. 28 is connected to TX VCO for modulation. The data code signal is modulated with the carrier frequency generated by the RF oscillator (Q5). The oscillator frequency is controlled by the error signal from pin no.3 of PLL IC (IC1). The modulated signal is amplified by RF amplifier stage (Q5) and then passes through 927MHz filter stage (F2). The FM modulated signal is radiated by the handset Rubberized Antenna.

### 1.5 VOICE TRANSMISSION

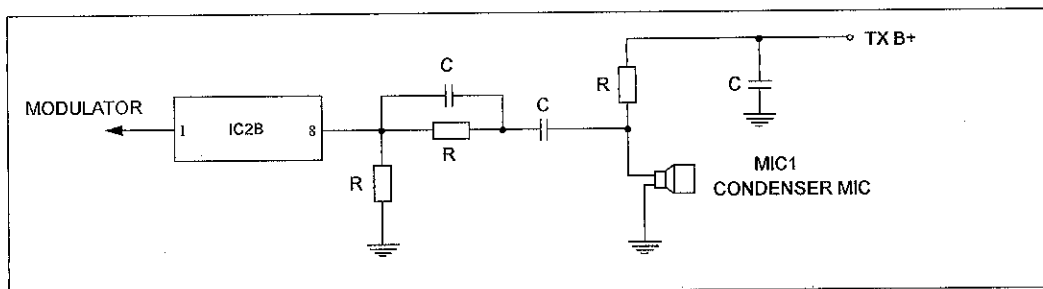

Figure 5

Voice signal from condenser mic is coupled to pin no. 8 of Compaider IC (IC2B). The voice signal is compressed by IC2B and then connected to TX VCO stage for modulation.

### 1.6 RECEIVER POWER CONTROL

- When at STANDBY mode and RING ON mode the handset has 50 ms power on and 800ms power off on receiver section.
- When at STANDBY mode and SAVE ON mode, the handset have no power on receiver section.
- The power saving is controlled by Microprocessor IC (IC1) pin no. 18 (RX power control) and Q1.

### 1.7 TRANSMITTER POWER CONTROL

- When at TALK mode, the handset transmitter should be working.
- The transmitter power is controlled by Microprocessor IC (IC1) pin no. 17 (TX power control) and Q6.

MH9012

### 1.8 BATTERY LOW DETECTOR

- When the battery voltage goes down until 3.3 to 0.1 Vdc, the LED1 will flash with warning sound "Bi, Bi".

### 1.9 BATTERY CHARGING

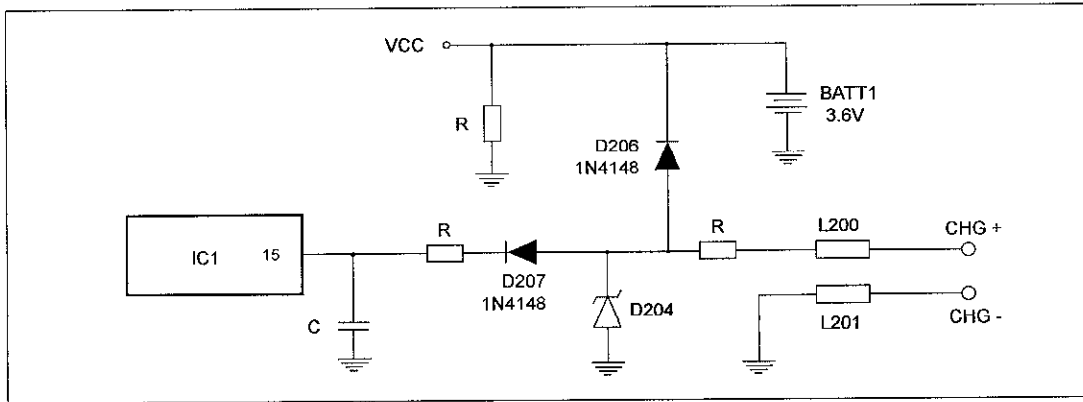

Figure 6

- When the handset is placed on the base unit cradle, the battery will be charging and will be detected by Microprocessor IC (IC1) pin no.15.
- Microprocessor IC will exchange security code randomly.

### 1.10 SQUELCH

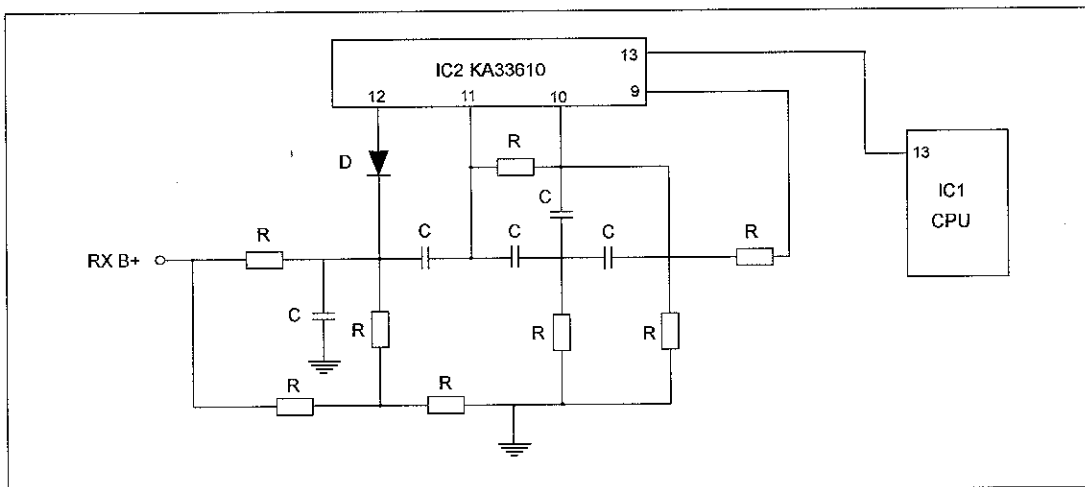

Figure 7

*MH9012*

As shown in figure 7, the audio output (noise output) from FM Demodulator IC (IC2) pin no.9 goes to pin no. 10 (Noise filter input) and the output from pin no. 11 will enter to pin no. 12 to activate the squelch control of IC2. The output from pin no. 13 is connected to the Microprocessor IC (IC1) for RSSI Detection.

**NOTE :**

- When the handset is far away from the base unit, squelch circuit of IC1 operates and pin no. 13 of IC1 goes 'HI'. This will be detected by Microprocessor and after 10 seconds, it goes to standby mode.

## **2. BASE UNIT**

### **2.1 RECEPTION**

Base receiver circuit is similar to handset receiver circuit description as shown in figure 1. The difference with section 1.1 are local frequency and receiving frequency as describe below.

The received signal from the handset unit passes through 927 MHz filter and amplified by RF RF Amplifier (Q8). The amplified signal is mixed with RX VCO (Q4,L1, D1).

The mixer output from Q3 passes through 10.7 MHz filter and enters to FM Demodulator IC (IC2) pin no. 16. This signal is mixed with 11.150 MHz signal from PLL IC (IC1) pin no.9, which is connected to IC2 pin no. 1. The mixed signal is filtered by 450 KHz Filter (FL4).

### **2.2 DATA INPUT**

The demodulated data code from FM Demodulator IC (IC2) pin no. 9 is fed to Lowpass filter and its output is connected to code input of Microprocessor IC (IC5).

### **2.3 AUDIO OUTPUT**

As shown in figure 8, the demodulated signal which appears at output pin of FM Demodulator IC (IC2) pin no. 9 is sent through lowpass filter to Compander IC (IC4A) pin no. 16 (Expander input) for expansion. The expanded audio signal output from IC4A pin no. 19 is coupled to Buffer Amplifier (Q2,Q9) during the CONVERSATION mode. The audio is sent to telephone line via Hybrid X'former (HYB1).

---

MH9012

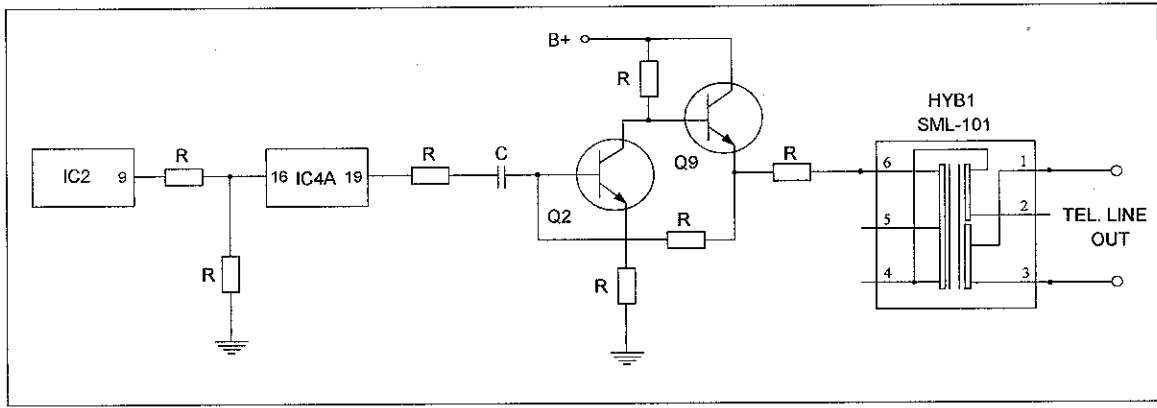

Figure 8

## 2.4 DATA TRANSMISSION

Refer to figure 4., the difference is that the TX Data is transmitted from pin 16 of Microprocessor IC (IC5).

## 2.5 VOICE TRANSMISSION

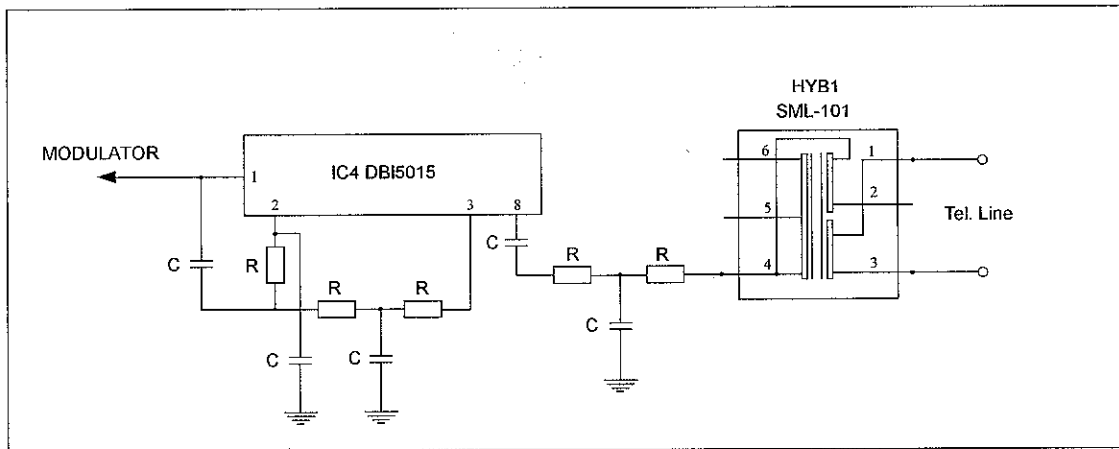

Figure 9

The audio signal receiving from telephone line is input to Componder IC (IC4B) pin no. 8 for compression. The compressed audio signal from pin no.1 of IC4B is connected to TX VCO for modulation. The signal is modulated with the carrier frequency of the oscillator (Q1), the oscillator frequency is controlled by the error signal from pin 3 of PLL IC. The modulated signal is amplified by RF Amplifier stage (Q5) and then passes through 903 MHz filter stage (F2). The FM modulated signal is radiated by the base unit antenna.

MH9012

2.6 DTMF OUT

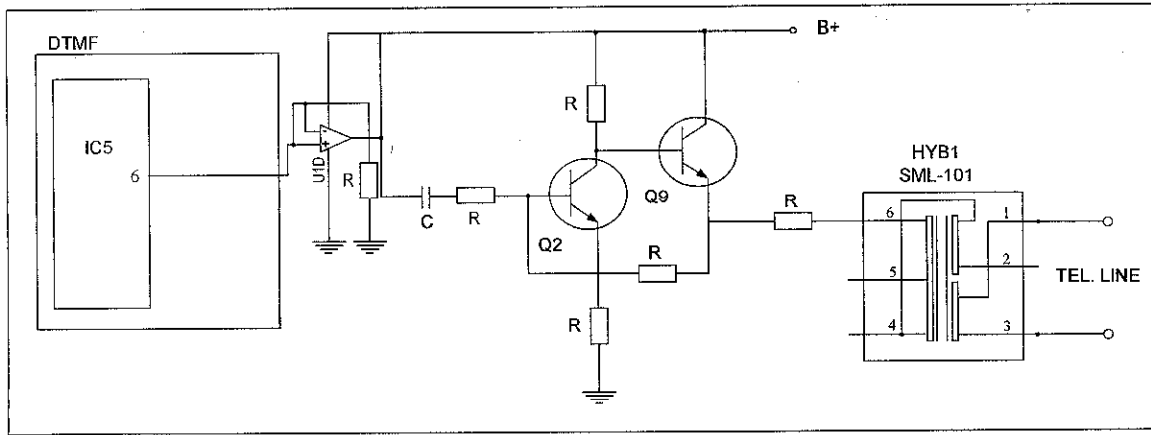

Figure 10

DTMF dialing is generated in pin no. 6 of Microprocessor IC (IC5) and output of U1D DTMF filter. (low pas filter and high pas filter)

2.7 TRANSMITTER POWER CONTROL

Transmit power is controlled by IC5 pin 19 and Q8 .

2.8 RINGER DETECT

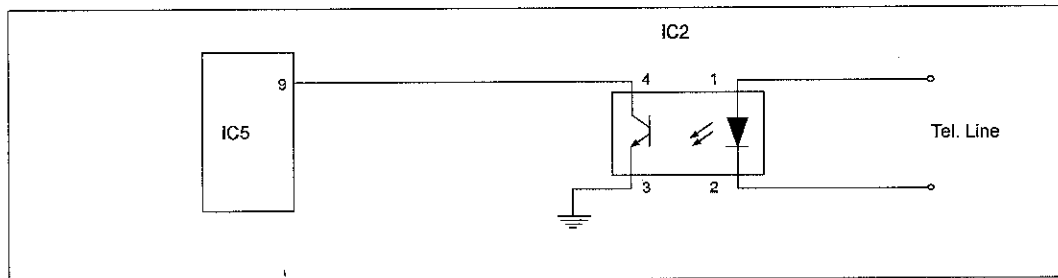

Figure 11

The ring signal from the telephone line is detected by Photocoupler (IC2) and the output from IC2 will be coupled to Microprocessor IC (IC5) pin no.9. After detection of ring signal, the microprocessor will send the data code to handset.

2.9 PULSE DIAL

During pulse dialing, IC5 CPU pin 20 will be sending pulse dial signal to Relay trigger (Q10) then goes to telephone line.



MH9012

## 2.10 CHARGE DETECT

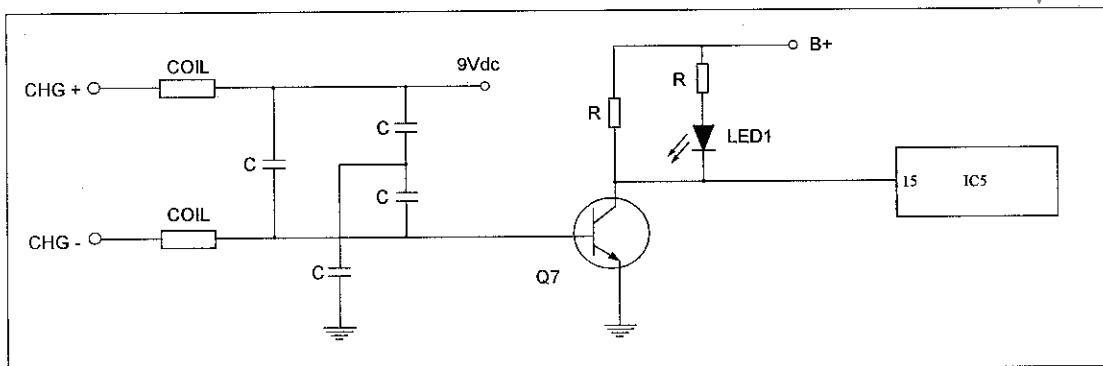

Figure 12

When the handset is on cradle, Q7 is activated and Microprocessor IC (IC5) pin 12 will detect the charging then it will exchange security code randomly.

## 2.11 SQUELCH

Refer to section 1.10. Squelch operation is same as handset as shown in figure 7.

## 2.12 PAGE FUNCTION

The Microprocessor IC (IC5) will detect page signal when IC5 pin no. 5 goes low (press SW2), IC5 will transmit paging signal from pin no. 16 (TX Data port).

## 2.13 RESET

When handset is place on cradle (charge) or insert the power plug into the socket, Base will reset automatically.