

CIRCUIT DESCRIPTION

1. HANDSET

1.1 RECEPTION

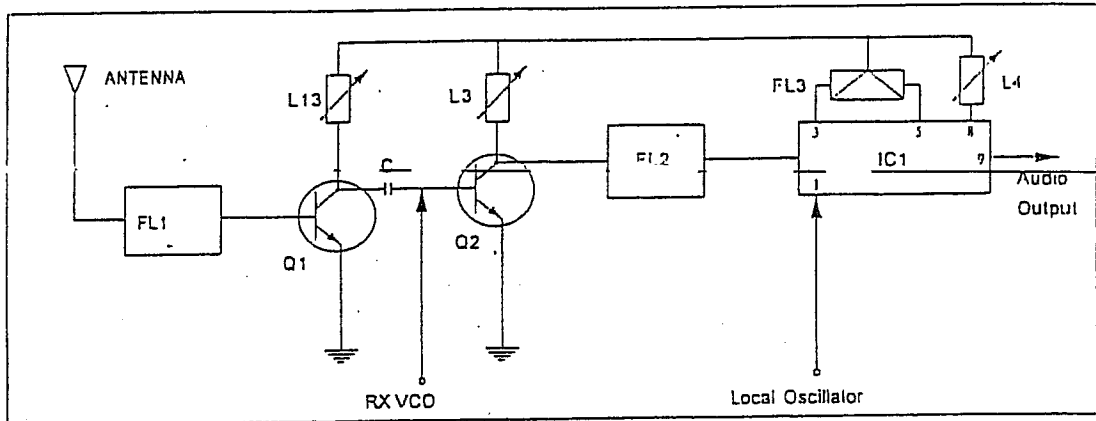

Figure 1

As shown in figure 1, the received signal from the base unit passes through 46 MHz Filter of FL1 and amplified by RF Amplifier (Q1). The amplified input signal is mixed with RX VCO (Q4, L15, D2) signal.

The VCO oscillation is controlled by error signals from PLL IC (IC3) pin no. 10. The channel information to PLL IC is provided by Microprocessor IC (IC4) pin nos. 19, 20 and 22. (Serial data outputs).

The Mixer output from Q2 passes through 10.7 MHz Ceramic Filter (FL2) and enters to FM Demodulator IC (IC1) pin no. 16. This signal mixes with 10.240 MHz signal from PLL IC pin no. 7, which is connected to IC1 pin no.1. The mixed signal is filtered by 455 KHz Filter (FL3).

1.2 RINGER OUTPUT

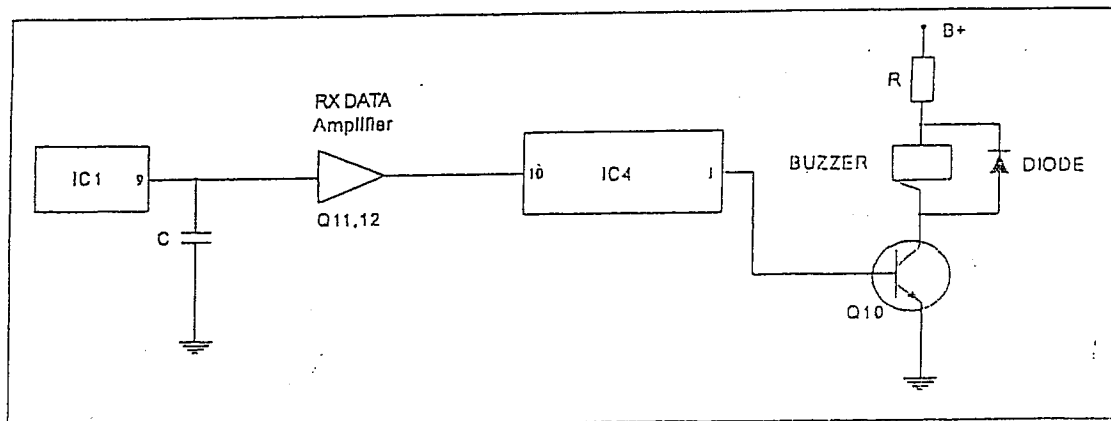

Figure 2

After detection of ring signal, the base unit will transmit the data code signal including security code to handset.

As shown in figure 2, the demodulated ring signal from pin no. 9 of FM Demodulator IC is fed to Low pass filter and amplified by RX Data Amplifier (Q11, 12) and its output is connected to RX Data port of Microprocessor IC (IC4).

The ring signal output from pin no1 of Microprocessor IC (IC4) goes to buzzer driver Q9 to activate the buzzer.

1.3 VOICE OUTPUT

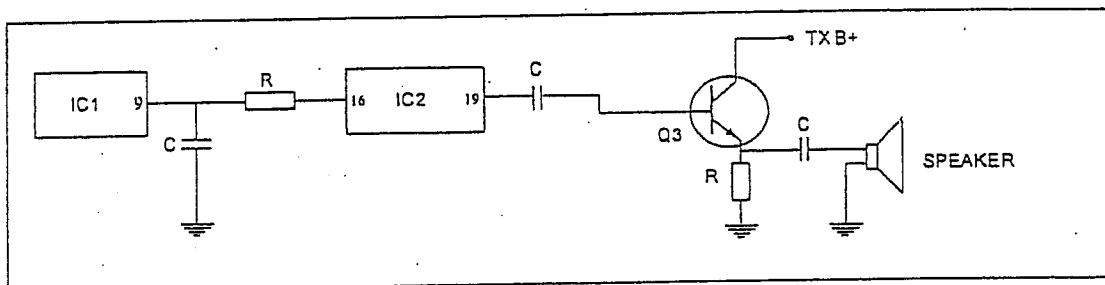

Figure 3

The demodulated signal, resulting from Double Super Heterodyne system, which appears at output pin no. 9 of IC1 is connected to pin no. 16 Expander input of Compañder IC (IC2) for expansion. The expanded audio output from IC2 pin no. 19 is finally amplified by Q4 and A.C. coupled to the receiver unit with Hearing Aid Compatibility (HAC).

1.4 DATA TRANSMISSION

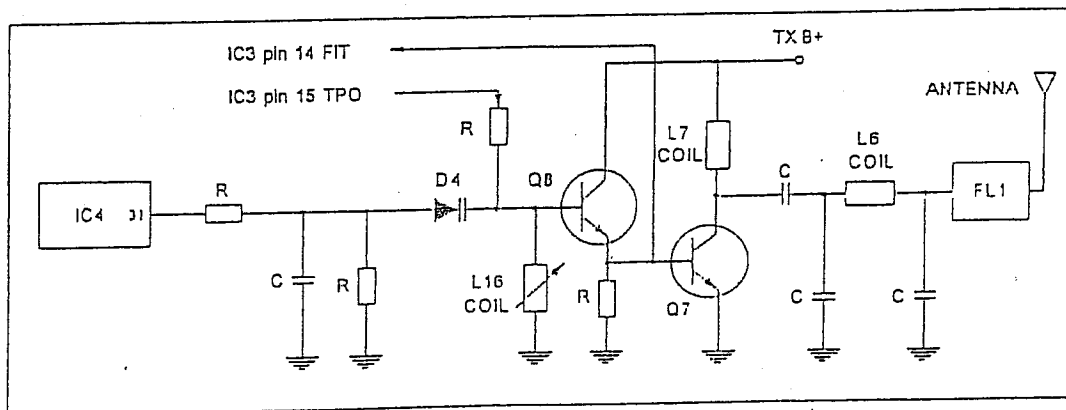

Figure 4

As shown in figure 4, the TX data code output including security code from IC4 pin no. 31 is connected to TX VCO for modulation. The data code signal is modulated with the carrier frequency generated by the RF oscillator (Q8). The oscillator frequency is controlled by the error signal from pin no.15 of PLL IC (IC3). The modulated signal is amplified by RF amplifier stage (Q7) and then passes through 49MHz filter stage (FL1). The FM modulated signal is radiated by the handset Rubberized Antenna.

1.5 VOICE TRANSMISSION

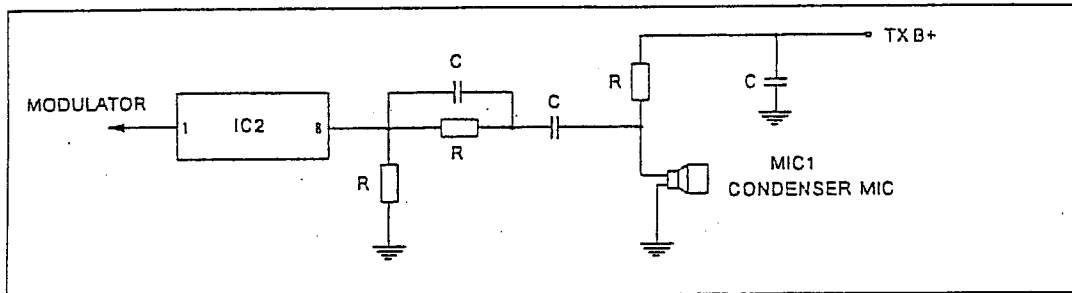

Figure 5

Voice signal from condenser mic is coupled to pin no. 8 of Compander IC (IC2). The voice signal is compressed by IC2 and then connected to TX VCO stage for modulation.

1.6 RECEIVER POWER CONTROL

- When at STANDBY mode and RING ON mode the handset has 50 ms power on and 800ms power off on receiver section.
- When at STANDBY mode and SAVE ON mode, the handset have no power on receiver section.
- The power saving is controlled by Microprocessor IC (IC4) pin no. 24 (RX power control) and Q5.

1.7 TRANSMIT POWER CONTROL

- When at TALK mode, the handset transmitter should be working.
- The transmitter power is controlled by Microprocessor IC (IC4) pin no. 26 (TX power control) and Q6.

1.8 BATTERY LOW DETECTOR

- When the battery voltage goes down until 3.3 to 0.1 Vdc, the LED1 will flash with warning sound "Bi, Bi".

1.9 BATTERY CHARGING

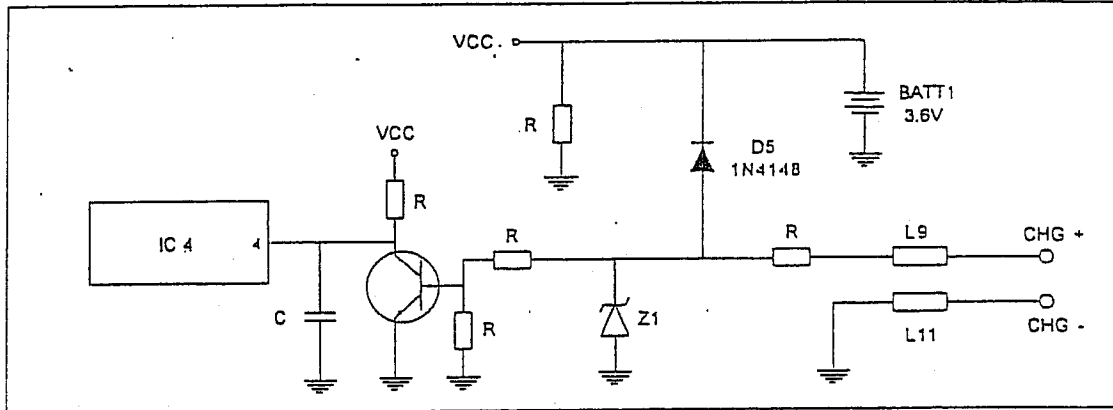

Figure 6

- When the handset is placed on the base unit cradle, the battery will be charging and will be detected by Microprocessor IC (IC4) pin no. 4.
- Microprocessor IC will exchange security code randomly.

1.10 SQUELCH

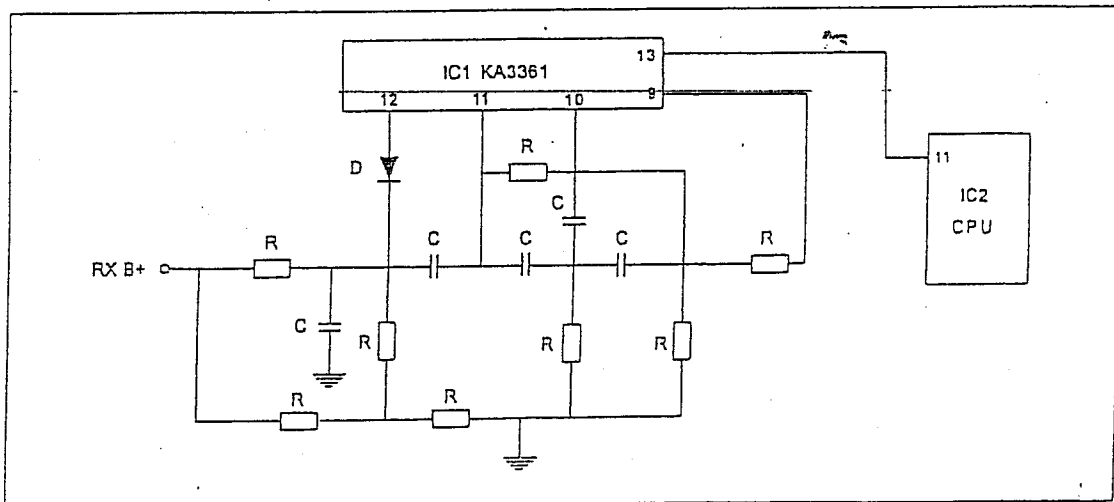

Figure 7

As shown in figure 7, the audio output (noise output) from FM Demodulator IC (IC1) pin no.9 goes to pin no. 10 (Noise filter input) and the output from pin no. 11 will enter to pin no. 12 to activate the squelch control of IC1. The output from pin no. 13 is connected to the Microprocessor IC (IC4) for RSSI Detection.

NOTE :

- When the handset is far away from the base unit, squelch circuit of IC1 operates and pin no. 13 of IC1 goes 'HI'. This will be detected by Microprocessor and after 10 seconds, it goes to standby mode.

2. BASE UNIT

2.1 RECEPTION

Base receiver circuit is similar to handset receiver circuit description as shown in figure 1. The difference with section 1.1 are local frequency and receiving frequency as describe below.

The received signal from the handset unit passes through 49 MHz filter of FL2 and amplified by RF Amplifier (Q1). The amplified signal is mixed with RX VCO (Q3, L4, D1).

The mixer output from Q2 passes through 10.7 MHz filter and enters to FM Demodulator IC (IC1) pin no. 16. This signal is mixed with 11.150 MHz signal from PLL IC (IC2) pin-no.7, which is connected to IC1 pin no. 1. The mixed signal is filtered by 455 KHz Filter (FL1).

2.2 DATA INPUT

The demodulated data code from FM Demodulator IC (IC1) pin no. 9 is fed to Lowpass filter and its output is connected to code input of Microprocessor IC (IC5).

2.3 AUDIO OUTPUT

As shown in figure 8, the demodulated signal which appears at output pin of FM Demodulator IC (IC1) pin no. 9 is sent through lowpass filter to Compaander IC (IC6) pin no. 16 (Expander input) for expansion. The expanded audio signal output from IC6 pin no. 19 is coupled to Buffer Amplifier (Q9, 20) during the CONVERSATION mode. The audio is sent to telephone line via Hybrid X'former (HYR1).

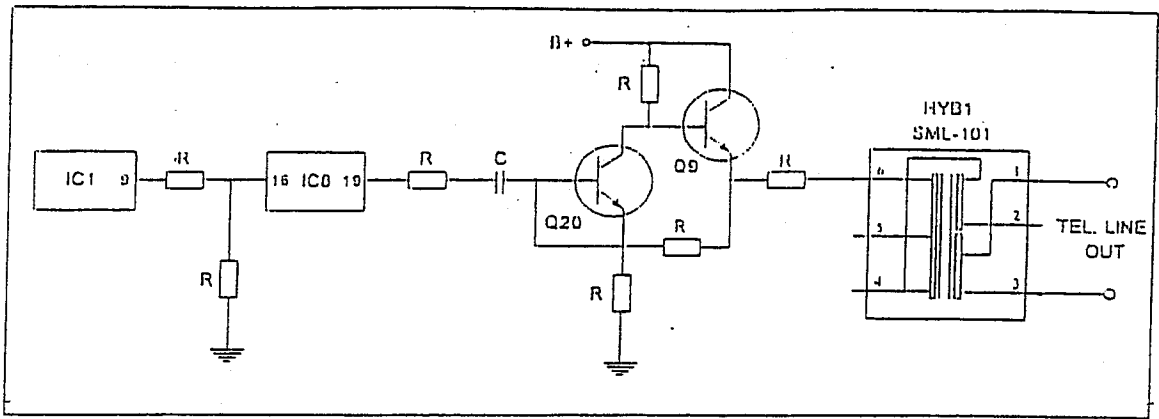

Figure 8

2.4 DATA TRANSMISSION

Refer to figure 4., the difference is that the TX Data is transmitted from pin 25 of Microprocessor IC (IC5).

2.5 VOICE TRANSMISSION

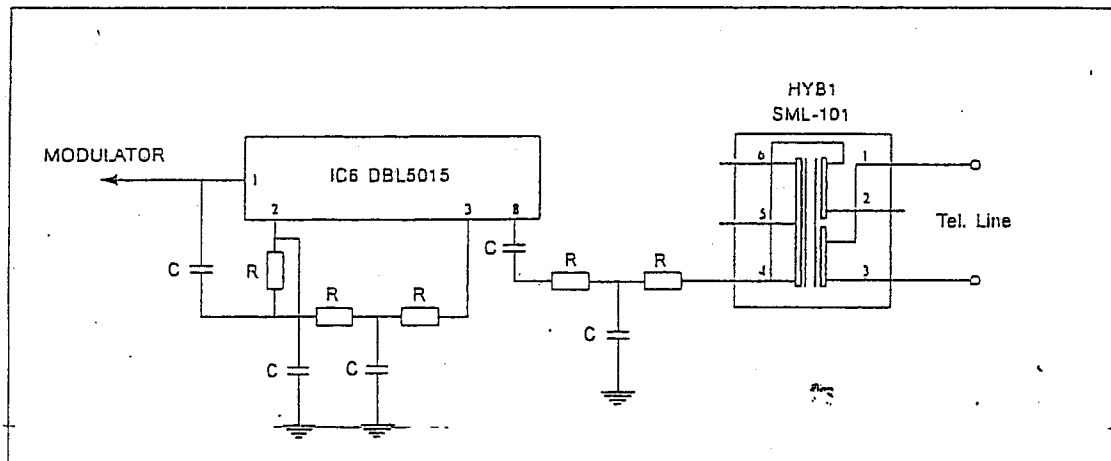

Figure 9

The audio signal receiving from telephone line is input to Comander IC (IC6) pin no. 8 for compression. The compressed audio signal from pin no.1of IC6 is connected to TX VCO for modulation. The signal is modulated with the carrier frequency of the oscillator (Q16), the oscillator frequency is controlled by the error signal from pin 15 of PLL IC. The modulated signal is amplified by RF Amplifier stage (Q17) and then passes through 46 MHz filter stage (FL2). The FM modulated signal is radiated by the base unit antenna.

2.6 DTMF OUT

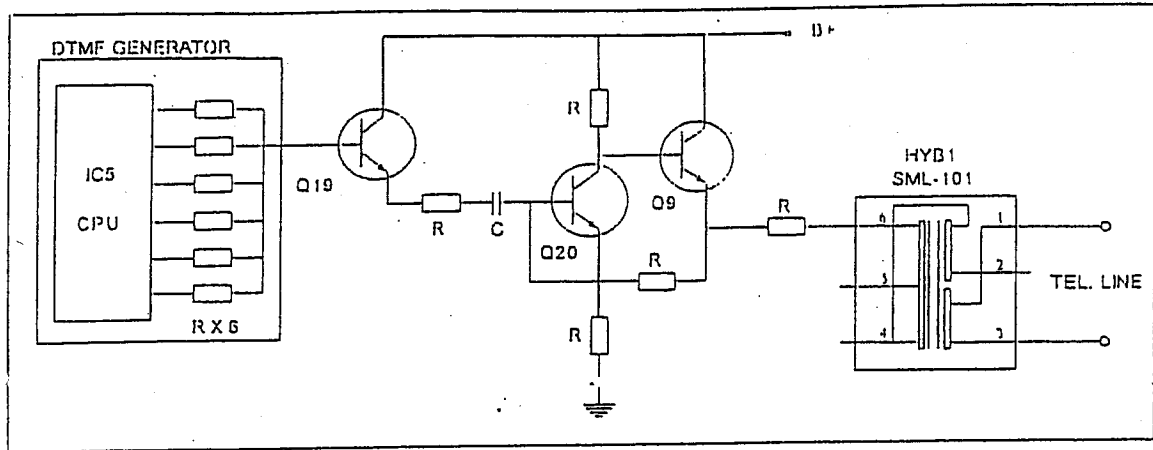

Figure 10

DTMF dialing is generated in pin nos. 18, 19, 20, 21, 22 and 23 of Microprocessor IC (IC5) and Resistors R64-69 and output through the emitter of Q19 (lowpass filter).

2.7 TRANSMIT POWER CONTROL

Transmit power is controlled by IC5 pin 24 and Q8 A539Y.

2.8 RINGER DETECT

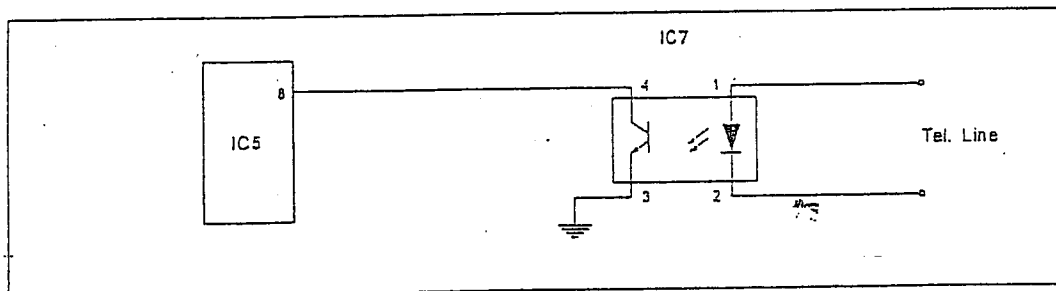

Figure 11

The ring signal from the telephone line is detected by Photocoupler (IC7) and the output from IC7 will be coupled to Microprocessor IC (IC5) pin no.8. After detection of ring signal, the Microprocessor will send data code to handset.

2.9 PULSE DIAL

During pulse dialing, IC3 CPU pin 28 will be sending pulse dial signal to Relay trigger (Q10) then goes to telephone line.

2.10 CHARGE DETECT

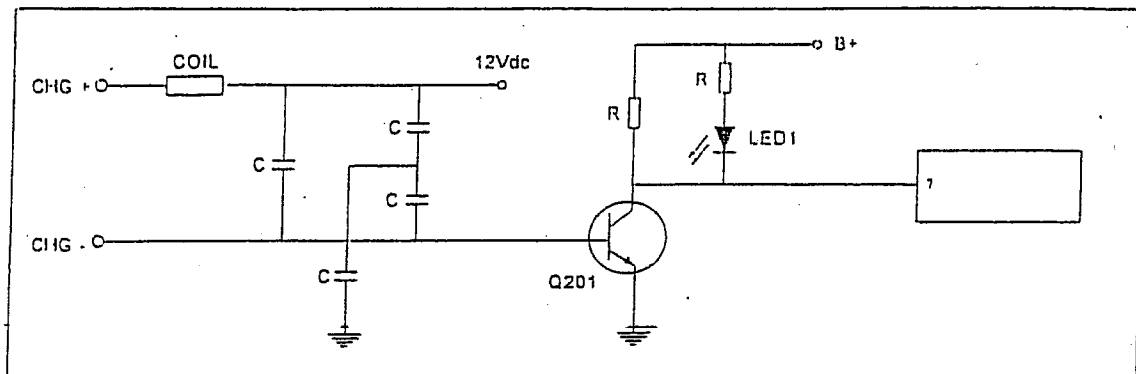

Figure 12

When the handset is on cradle, Q201 is activated and Microprocessor IC (IC5) pin 1 will detect the charging then it will exchange security code randomly.

2.11 SQUELCH

Refer to section 1.10. Squelch operation is same as handset as shown in figure 7.

2.12 PAGE FUNCTION

The Microprocessor IC (IC5) will detect page signal when IC5 pin no. 4 goes low (press SW2), IC5 will transmit paging signal from pin no. 31 (TX Data port).

2.13 RESET

When handset is place on cradle (charge) or insert the power plug into the socket, Base will reset automatically.