

Allflex Worldwide Sales Offices:

Allflex Europe
ZI. de Plagué
Route des Eaux, B.P. 90219
35502 Vitre Cedex, France
Tel 33 (0)2.99.75.77.00
Fax 33 (0)2.99.75.77.29

Allflex USA, Inc.
P.O. Box 612266
Dallas/Ft. Worth Airport
Texas 75261-2266
Tel (972) 456-3686
Fax (972) 456-3882

Allflex Australasia
Private Bag 11003
Palmerston North
New Zealand
Tel 64 (06) 356-7199
Fax 64 (06) 358-5982

<http://www.allflex-boulder.com>

FCC ID: NQY-930040

Note: This equipment has been tested and found to comply with the limits for a Class A digital device pursuant to Part 15 of the FCC Rules. These limits are designed to provide reasonable protection against harmful interference when the equipment is operated in a commercial environment. This equipment generates, uses, and can radiate radio frequency energy, and if not installed and used in accordance with the instruction manual, may cause harmful interference to radio communications. Operation of this equipment in a residential area is likely to cause harmful interference in which case the user will be required to correct the interference at his own expense.

This device has been tested and meets the Electromagnetic Compatibility (EMC) requirements of EMC Directive 2004/108/EC and R&TTE Directive 99/5/EC.

Caution

This equipment has been designed, constructed, and tested for compliance with FCC Rules that regulate intentional and unintentional radiators. The user is not permitted to make any modifications to this equipment or use it in any manner inconsistent with the methods described in this User Manual, without express approval from Allflex. Doing so will void the user's authority to operate this equipment.

Trademark Notices

Hyperterminal® is a registered trademark of Hilgraeve, Inc.
MS-Windows® is a registered trademark of Microsoft, Inc.
Configurator® is a registered trademark of Allflex USA, Inc.

Other Agency Certification Notices

Industry Canada EMC Certification No. 4246A- _____

Allflex ISO Compatible RFID Stick Reader Model RS250-V2 User Manual

(Revision B - June 2006 / Software V3.05+)

Preparing for Use

Unpacking

The Allflex Stick Reader is shipped in a box with this instruction guide, DC power plug pigtail cable (for battery connection), and Configurator® diskette. Information contained in this guide pertains to providing power to the Reader, connecting its serial data port, setting configuration options using the Reader's serial port, and operating the Reader. In order to proceed, it is necessary that the user have a suitable power source (see Page 2 of this guide) and an assortment of ISO transponders.

Stick Reader User Interface

The photograph (Figure 1) below illustrates the Stick Reader's features that comprise the user interface and are pertinent to its operation. Each feature and its corresponding functional description of use are described in Table 1.

Figure 1 - Stick Reader Features and User Interface

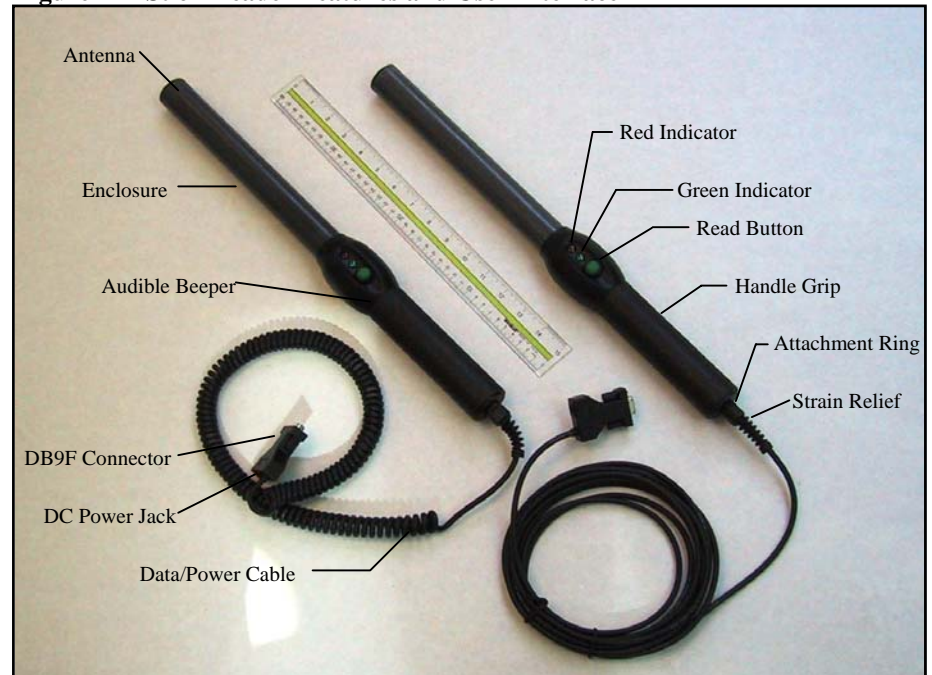

Table 1 - Stick Reader Features and Descriptions of Use

Feature	Description of Use
Antenna Coil ¹	Emits activation signal and receives transponder signal
Red Indicator	Illuminates whenever antenna is emitting activation signal
Green Indicator	Illuminates whenever a transponder has been read
Audible Beeper ¹	Beeps once on first transponder reading and twice for repeat
READ Button	Initiates activation signal for reading transponder
Data/Power Cable	Conveys power to Reader and serial data from Reader
DB9F Connector	Connects serial data to PC or data logger RS232 port
DC Power Jack	Accepts 6 to 12 VDC input as Reader power source
Enclosure	Rugged, fiberglass, watertight case
Attachment Ring	Allows lanyard attachment for hanging
Handle Grip	Rubber anti-slip gripping surface
Strain Relief	Watertight cable entry

¹Item is internal to enclosure and cannot be seen in Figure 1 photograph

Power Source Requirements

The Stick Reader can be powered from a variety of DC power source options, either through the DC power jack or through pin 9 on the DB9F connector. Recommended DC Power sources are the Allflex PW50, PW250, or RFL100 Portable Rechargeable Battery Pack, or PW409 AC Power Supply, which attaches to the DC Power Jack.

Note 1 - Certain weigh scales and other equipment to which the Stick Reader can be attached provide DC power on pin 9 of the DB9 interface connector. Such DC power sources are acceptable as long as the voltage is between 6 and 12 volts DC, and are capable of providing at least 500 milliamperes continuous current, and at least 1.0 ampere peak current. Pin 5 of the DB9 connector is ground. A rechargeable sealed lead acid battery rated at 6 volts and 4.5 ampere-hours or greater is an excellent choice for portable and field applications.

Note 2 - When an external power source is connected to the DC Power Jack, inserting the plug causes electrical continuity to pin 9 of the DB9 connector to be interrupted. Polarity on the DC Power Jack is sleeve + and center pin -. The DC power plug specification is a 2.5mm x 5.5mm DC Coaxial (9.5mm length).

Note 3 - An AC power supply must be a linear regulated type unit rated at 6 to 12 VDC output and 1.0 amperes minimum. Some AC power supplies may exhibit excessive noise that can compromise read range of FDX-B type transponders. Suitable AC power supplies should be rated at 3 millivolts or less output ripple.

Note 4 - The Stick Reader does not contain a power on/off switch. When a power source is connected to either the power jack of pin 9 of the DB9F connector, the Stick Reader will consume an idle current of approximately 25 milliamperes. When powered from a battery source, be sure to disconnect the battery when the Stick Reader is not in use in order to conserve battery life.

Note 5 - The Stick Reader is polarity protected against accidental reverse voltage application and will not be damaged by such.

SPECIFICATIONS:

GENERAL	
RFID Compatibility:	ISO 11784 & 11785 HDX and FDX-B
Form Factor:	Portable Handheld Fiberglass Rod Enclosure w/Rubber Handle Grip
User Interface:	Single "Press to Read" Activation Button Red LED "Exciter Active" Visual Indicator Audible Beeper and Green LED "Good Read" Visual Indicator RS232 Serial Data Port Software upgradeable via RS232 serial port
RS232 Serial Port:	1200 BPS to 57.6 KBPS (9600N81 default setting)
Serial Data Format	Decimal or Hexadecimal Mfr/Country Code + National ID Code
Memory:	Stores up to 1638 transponder codes in non-volatile memory for download
User Options:	Non-volatile mode control options selectable via RS232 serial port interface
Power/Data Interface:	1 meter coiled cable (extends to 3 meters) or 5 meter straight cable w/DB9(f) connector & 2.5mm x 5.5mm coaxial power jack
Battery Power:	6 to 12 VDC External Battery or Mains Powered Supply
Electromagnetic Compatibility (EMC)	FCC Part 15 Class A CISPR 22 (EN55022), and EN50082-1
Certifications:	ETSI 300 330-2 Industry Canada RSS-210
PHYSICAL/ENVIRONMENTAL	
Dimensions:	RS250-45: 45cm L x 32mm diameter (18" x 1.25") RS250-60: 60cm L x 32mm diameter (24" x 1.25")
Weight:	0.62 kg. (22 ounces)
Material:	UL94V0 Fiberglass and ABS UL94 HB Plastic
Color:	Black/Gray
Operate Temperature	-40°C to +55°C (IEC68.2.1/.2)
Storage Temperature	-40°C to +85°C (IEC68.2.1/.2)
Humidity:	0 to 95% (IEC68.2.56)
Altitude:	-100 to +3,000 meters
Mechanical Shock:	Per IEC 68-2-27 (15g/11mS sawtooth) & 1 meter free-fall drop onto concrete)
Vibration:	Per IEC 68-2-6 (10-55 Hz sinusoidal/0.75mm displ./1 oct/min./10 cycles)
Hermeticity:	IP-67 (dust-tight/immersible) per IEC 529
RELIABILITY	
MTBF:	50,000 hours
MTTR:	0.5 hours (not field serviceable)
Expected Life:	5 years, minimum
PERFORMANCE	
Read Distance:	27cm (minimum - Allflex 30mm HDX/HP eartag) (@ 6 VDC) 20cm (minimum - Allflex 31mm FDX-B eartag) (add 5 cm for 12VDC)
Reading Orientation:	0° to 45° with less than 10% range decrease
Read Zone:	360° in radial and axial planes with respect to end of reader enclosure
Interrogation Rate:	~ 9 times/second
Read Error Rate:	Less than 1 in 10 ⁶
Exciter Signal	81 dBuV/m @ 10 meters with 6VDC power input
Field Strength:	87 dBuV/m @ 10 meters with 12VDC power input

ID Code Memory

The Stick Reader contains an internal non-volatile memory capable of storing 1638 ID codes. ID codes are stored automatically upon being read. A transponder ID code will not be stored multiple times if read multiple times successively, but can be stored in memory multiple times if other tags are read in between. All ID codes are retained when power to the Stick Reader is shut off. If more than 1638 ID codes are read, the new ID codes are written over the oldest ID codes in a wrap-around manner.

ID Codes can be retrieved from the Stick Reader via its RS232 serial port by issuing to the Reader a <G> command (see Table 5 on page 9). The <G> command can be issued as many times as desired, and the complete memory contents will be transferred upon each event. ID codes are not erased from the memory until a <C> command is received.

Each ID code is followed by a <CR><LF> (carriage return/line feed) which will cause each ID code to appear on a separate line of a PC display. The Stick Reader contains a configuration option that automatically inserts a null identification code in memory upon application of power to the Reader. This provides a means of establishing partitions in memory between blocks of ID codes that represent separate groups of identified animals, thus facilitating the management of ID code data once downloaded to a PC database. To set this partitioning marker, use the command <M02> (the default state is M00).

Stick Reader Physical Integrity

The Stick Reader has been constructed from rugged and durable materials to provide long periods of service in harsh environments. It is water proof, and can withstand immersion in water in use and for cleaning. The Stick Reader does contain electronic components, however, that can be damaged if subjected to extreme intentional abuse, and such damage can deteriorate or terminate the Reader's functioning. The user should refrain from intentionally striking other surfaces and objects with the Stick Reader. Damage resulting from such is not covered by the Limited Product Warranty describe below.

Limited Product Warranty

Allflex warrants this product against any defects that are due to faulty material or workmanship for a period of one year after date of purchase. This warranty does not apply to any damage to the product resulting from accident, misuse, modification, or application other than that for which it is intended and that is described within this User Manual.

If the product should become defective within the warranty period, Allflex will repair or replace it at no charge. Allflex will return the product, shipping paid, provided it is shipped at customer cost to Allflex. To obtain a return material authorization (RMA) code, please call Allflex at 303/449-4509, or contact your Allflex sales representative.

Serial Data Interface Requirements

The RS232 serial data interface comprises a 3 wire arrangement with a DB9F connector, and consists of transmit (TxD/pin 2), receive (RxD/pin 3), and ground (GND/pin 5). This interface can be configured for a variety of communications parameters, and is factory configured with default settings of 9600 bits/second, no parity, 8 bits/word, and 1 stop bit ("9600N81"). To change these default settings, please see "Configuration Options" on pages 8 and 9 of this guide. Figure 2 illustrates the power and data wiring of the Power Jack and Data Connector.

Note 6 - The Stick Reader RS232 interface is wired as a DCE (data communications equipment) type that connects directly to the serial port of a PC or any other device that is designated as a DTE (data terminal equipment) type. When the Stick Reader is connected to other equipment that is also wired as DCE (such as a PDA), a "null modem" adapter is required in order to properly cross-wire transmit and receive signals so that communications can occur.

Note 7 - The Stick Reader's serial data connection can be extended using the Allflex AY005 (10 meter) or AY006 (20 meter) extension cable. Extensions longer than 20 meters (~65 feet) are not recommended.

Figure 2 - Stick Reader Power Jack and Data Connector Wiring Diagram

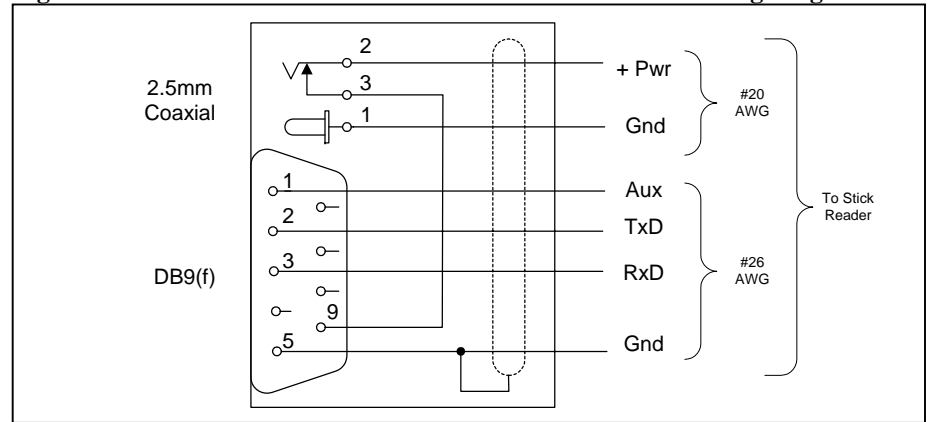

Serial data appears on the Stick Reader's TxD/pin 2 connection in ASCII format, which is compatible with most PC terminal emulator programs, such as Hyperterminal®. Configuration options provide flexible parsing and formatting of transponder ID code information (see "Configuration Options" on pages 8 and 9 of this guide). The default formats for ISO transponder tag types are listed in Table 2.

Table 2 - Default Serial Data ID Code Formats

Tag Type	Default Format
HDX ISO	LA_982_000001088420<CR><LF>
HDX Industrial	LR_0006_0000000018514243<CR><LF>
FDX-B ISO	LA_982_000000255895<CR><LF>

Note: _ = space; <CR> = carriage return; <LF> = line feed

Stick Reader Setup

Basic Operating Procedure

The Stick Reader is configured at the factory with default configuration settings that make it immediately functional upon application of power. These settings are selected for compatibility with most users' applications, and should be changed only once a thorough understanding of options and the effect of each is understood by the user.

Note 8 - In the event configuration options are inadvertently changed, it is possible to lose the ability to communicate with the Reader as a consequence of not knowing the communications parameters that are in effect. Factory default configuration (see page 8) can be restored by holding down the READ button while applying power. After approximately 2 seconds, the Reader will respond with 6 flashes of its green LED indicator (and 6 audible beeps) indicating that default settings have been restored.

Step 1 - Determine the method by which power will be applied to the Stick Reader (see *Power Source Requirements* on page 2 of this guide), and connect power accordingly. Observe a brief flashing by both LED indicators and audible beep.

Step 2 - Press the READ button momentarily, and observe the red LED flashes for approximately 3 seconds, and then extinguishes.

Step 3 - Press the READ button again, and bring a transponder tag within 15 cm (6") of the end of the antenna where antenna is located (see Figure 3). Observe the green LED indicator illuminates simultaneously with the audible beeper, indicating a successful read, and the red LED ceases flashing.

Step 4 - Repeat Step 3 using the same transponder, and observe a double flash/double beep, indicating that the same transponder tag has been read.

Step 5 - Connect the DB9F serial data connector to a PC's COM1 port (usually the port assigned to RS232 serial communications), and launch a terminal emulator program such as Hyperterminal®. Set the PC's communications parameters to 9600 bits/second, no parity, 8 bits/word, 1 stop bit, and no flow control (9600N81).

Step 6 - Using a different transponder tag than first used in Step 3, repeat Steps 3 and 4. Observe that the transponder ID code is sent from the Reader to the PC each time it is read. Also observe that the tag data format conforms with those examples listed in Table 2.

Note 9 - Even if the user's application intends the Stick Reader to be connected to equipment other than a PC, proceeding as described above will confirm the establishment of communications with a PC so that (a) Stick Reader operation is verified, (b) the user becomes familiar with the basic operation, and (c) configuration options can be changed via the PC in the event the user's application requires settings other than the default settings.

Table 5 - Frequently Used Command Language Characters

Command	Application
P	Reader's current settings are sent in command language format
Bnnnnnn	Configures ID code serial data format
Snn	Sets serial data communications parameters
Inn	Sets miscellaneous options
r	Resends the last tag read
G	Retrieves all ID codes stored in memory
M	Sets ID code memory options
C	Clears ID memory (requires <CR>)
? or H	Retrieves list of valid Command Language characters

Note 15 - In Table 5, commands followed with "n" (hexadecimal characters) require the user to press the PC's <Enter> key after typing in all command characters. Single letter commands do not require <Enter> to be pressed, except as noted in Table 5.

Command Language Examples:

Retrieve Current Configuration Settings:

User:	P	
Reader:	Allflex Stick Reader	Product Identity
	*HW V1.00	Hardware Version Number
	*SW V1.06	Software Version Number
	*PR V2.21	Protocol Version Number
	*B-840239	Serial Data Format Setting
	*S-4C	RS232 Settings
	*I-01	Miscellaneous Settings
	*M-00	Memory Options
	*A-3	Read Time Interval
	*L-0000	Memory ID Codes Stored
	*F-1638	Memory ID Codes Vacant

Change Communications Bit Rate to 1200 BPS:

User:	S49<CR><LF>	(<CR><LF> same as 'Enter')
Reader:	*S-49<CR><LF>	Command Confirmed

Change ID Code Transmit Format to Hexadecimal:

User:	B850239<CR><LF>	(<CR><LF> same as 'Enter')
Reader:	*B-850239	Command Confirmed

Start Read Cycle:

User:	R	(<CR><LF> not required)
Reader:	LA_982_000000678234<CR><LF>	(if tag found)

For a complete description of all commands and configuration option variables, please refer to the Stick Reader Serial Command Language Manual.

Configuration Options

The Stick Reader provides a variety of user customization features that allow its operation, behavior, and output data format to be configured for compatibility with the user's application. All of these options are set by sending the Stick Reader certain commands via its RS232 serial communications interface. Once changed, the Stick Reader retains these settings in memory permanently (even when power is disconnected) until they are intentionally changed by the user.

Default Configurations

Table 4 lists the default configuration settings with which the Stick Reader is optioned when shipped.

Table 4 - Default Configuration Options

Option	Default Configuration
Serial Data Format	Per table 2, duplicate tag reads transmitted
Serial Hardware	9600 BPS, no parity, 8 BPW, 1 stop bit, no flow control
Miscellaneous	Beeper/LED = on, push-to-read, wireless sync = off
Read Time	3 seconds

Briefly, Serial Data Format settings determine the presentation of the ID code data to the user's device that is connected to the Stick Reader's serial port. Serial Hardware settings establish the Reader's communications parameters for compatibility with the user's device. Miscellaneous settings control various operational characteristics of the Reader. Read Time is the interval for which the Reader's tag activation signal remains on when the READ button is pressed and released.

Changing Configuration Options

Configuration options are changed by connecting the Stick Reader's data cable to the serial port on a PC, and applying power to the Reader. Once communications have been established (see "Stick Reader Setup" on page 4 of this guide), either of two methods can be used to change the Reader's configuration. The first method uses a terminal emulator program, such as Hyperterminal®, and requires the user to send short alphanumeric coded command instructions to the reader. The second method uses the Allflex *Configurator*® MS-Windows® based PC utility software program, which allows the user to select configuration options from a series of drop-down menu choices.

Serial Command Language Method - Basic Instructions

The following instructions describe some of the basic and more frequently used configuration options, and illustrates how to implement them using the Stick Reader Serial Command Language in conjunction with Hyperterminal®. The Command Language method uses upper and lower case alpha characters combined with hexadecimal characters to establish the Reader's configuration. The most common commands are listed in Table 5.

Reading Transponder Tags

The Stick Reader is always ready to read a transponder tag when power has been applied to it. Initiating a tag reading event requires only a press of the READ button. When the READ button is pressed and released, the tag activation signal is present for a 3 second interval. Alternately, the READ button can be held down, and the activation signal will remain on until the READ button is released or until a tag has been read. The tag activation *on* state is always indicated by the red LED indicator illuminating.

Note 10 - The 3 second tag activation on signal interval can be configured for times ranging between 1 second and 9 seconds, in 1 second increments. The default time interval is 3 seconds.

Note 11 - The Stick Reader can be configured for a continuously *on* activation signal, thus eliminating the need to press the READ button. In this mode the activation signal automatically continues after every tag read. This mode should be used only when (a) powering the Stick Reader from a 6 VDC source, (b) when interference with other tag readers is not likely, and (c) when powering the Reader from a source that can provide sufficient operating time. Use the command <I05> to activate continuous reading (see page 9).

Figure 3 illustrates the read zone of the Stick Reader, within which tags can be successfully detected and read. Optimum read distance occurs when the tag antenna is aligned with the Stick Reader's antenna as shown. When the tag is at the end of the Stick Reader, optimum read distance coincides with a coaxial orientation of the antennas, and when the tag is adjacent to the Stick Reader, optimum read distance coincides with a planar orientation of the antennas.

Figure 3 - Optimum Read Distance Tag Orientation

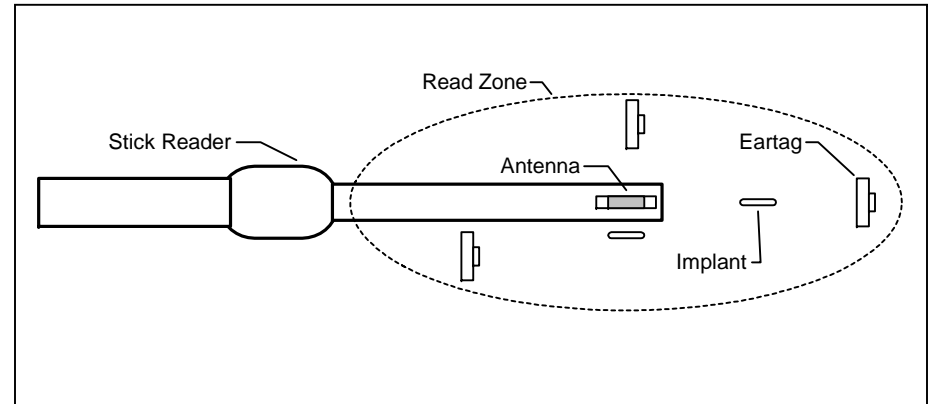

Table 3 lists typical read distances that can be expected when operating the Stick Reader at different power levels and when reading different types of Allflex eartags, in the optimum tag orientation at the end of the Stick Reader (as shown in Figure 3).

Table 3 - Typical Read Distances for Various Allflex Eartags

Tag Type	6 VDC (81 dBuV/m @10m)	12 VDC (87 dBuV/m @10m)
HDX/HP Eartag	28 cm	35 cm
HDX/LW Eartag	22 cm	30 cm
FDX-B/HP Eartag	24 cm	27 cm
FDX-B/LW Eartag	20 cm	24 cm

Note 12 - Figures listed in Table 3 underneath input voltage levels represent field strength levels. It is the user’s responsibility to ensure that the Stick Reader is operated within the legal power limits regulated by the local telecommunications authority.

Read Range Performance

Tag readers are frequently assessed with respect to performance by their reading distance. The read distance performance of the Stick Reader will be affected by the following:

Transponder Orientation - For maximum reading distance, the axes of the transponder and reader antenna coils must be optimally oriented (see Figure 3).

Transponder Quality - Each manufacturer’s transponder differs in (a) the amount of exciter signal energy necessary to sufficiently operate the transponder’s internal circuitry, and (b) the signal level of the ID Code information that is returned to the reader. Consequently, it is normal for transponders of a common type (FDX-B, for example) made by different manufacturers to exhibit different read range performance characteristics.

Transponder Motion - Most portable readers have small antenna geometries, and consequently produce small effective “read zones”. Portable readers are generally designed for reading transponders under quasi-static conditions. Transponders that are moving quickly past the reader may not be present within the reader’s read zone sufficiently long for all the ID Code information to be obtained.

Transponder Size - Physically larger transponders generally contain larger receiving coils which produce longer reading distances than smaller transponders.

Transponder Type - HDX transponders generally exhibit greater reading distances than FDX-B transponders of comparable size.

Proximal Metallic Objects - Metal objects located near the transponder or Reader can attenuate and distort the electromagnetic fields generated in RFID systems, and thus diminish read distance performance.

Electrical Noise Interference - RFID transponders and readers use electromagnetic signals as a premise of operation. Other electromagnetic phenomena – radiated electrical noise from computer displays, for example – can interfere with the transmission and reception of RFID signals, and consequently reduce reading distance.

Transponder/Reader Interference - Multiple transponders within the sensing range of the reader, or other readers emitting excitation energy in the immediate vicinity can adversely affect the reading performance or prevent operation of the Stick Reader.

Interpreting Tag ID Code Information

Table 2 lists the default data formats that are transmitted from the Stick Reader’s serial communications port, in response to reading compatible type tags. For ISO type tags, there is no contextual differentiation between HDX and FDX-B outputs. Both types of tags produce a default format:

LA_982_000001088420<CR><LF>

where the underscore “_” represents a space character, and <CR><LF> is a carriage return /line feed (unprinted control characters which cause a PC’s display cursor to jump to the beginning of the next line prior to displaying the next ID number).

In the above data output, the prefix “LA” represents “Line mode – Animal coded read only tag”, “982” is the Allflex manufacturer number assigned by ICAR, and the last 12 digits comprise a unique number sequence for this particular transponder.

The TIRIS S2000 output format has become a de facto standard for many users, and appends the *reserved field* and *data block* bits contained in the ISO coded eartag to the Stick Reader’s default format, causing the ID code information to appear in the format:

LA_00000_0_982_000001088420<CR><LF>

This output is easily configured using either the *Configurator*® utility, or by issuing the Command “BE40239” to the Stick Reader (See Serial Command Language on page 8).

Note 13 - The manufacturer code “982” will be different for another manufacturer’s tag, and can also be replaced by an ISO country code or abbreviation (“250” or “FRA” = France, for example). When other manufacturer codes or country codes exist, there can exist the same 12 digit ID number.

Note 14 - While HDX and FDX-B type transponders have an identical context, they are guaranteed by Allflex to be unique. That is, HDX tag type ID numbers are never duplicated in FDX-B type tags.

For HDX Industrial coded tags, the output format is:

LR_0006_0000000018514348<CR><LF>

In this tag format, the prefix “LR” represents “Line mode – industrial coded Read only tag”, “0006” is an application code unique to Allflex, and the last 16 digits comprise a unique identifying number sequence.

The above default formats can be changed using the features described in the section “Configuration Options” on pages 8 and 9 of this guide.