

# HPR Lite User Manual

Revision 1



**Biomark**  <sup>®</sup>  
SPECIALISTS IN IDENTIFICATION SOLUTIONS

## Regulatory Information

### USA-Federal Communications Commission (FCC)

This device complies with part 15 of FCC rules. Operation is subject to the following two conditions: (1) This device may not cause interference, and (2) this device must accept any interference, including interference that may cause undesired operation of the device.

This equipment has been tested and found to comply with the limits for a Class B digital device, pursuant to Part 15 of FCC Rules. These limits are designed to provide reasonable protection against harmful interference in a residential installation. This equipment generates, uses, and can radiate radio frequency energy. If not installed and used in accordance with the instructions, it may cause harmful interference to radio communications. However, there is no guarantee that interference will not occur in a particular installation. If this equipment does cause harmful interference to radio or television reception, which can be determined by tuning the equipment off and on, the user is encouraged to try and correct the interference by one or more of the following measures:

- Reorient or relocate the receiving antenna.
- Increase the distance between the equipment and the receiver.
- Connect the equipment to outlet on a circuit different from that to which the receiver is connected.

Consult the dealer or an experienced radio/TV technician for help.

This portable equipment with its antenna complies with FCC's radiation exposure limits set forth for an uncontrolled environment. To maintain compliance, follow the instructions below:

- (1) This transmitter must not be co-located or operating with any other antenna or transmitter;
- (2) Avoid direct contact to the antenna, or keep contact to a minimum while using this equipment.

Notice to consumers:

Any changes or modifications not expressly approved by the party responsible for compliance could void the user's authority to operate the equipment.

### Canada - Industry Canada (IC)

This device complies with Industry Canada's license-exempt RSSs. Operation is subject to the following two conditions:

- (1) This device may not cause interference, and
- (2) this device must accept any interference received, including interference that may cause undesired operation of the device.

Notice to consumers:

Any changes or modifications not expressly approved by the party responsible for compliance could void the user's authority to operate the equipment.

## Miscellaneous Information

Snapshots are according to the latest version at the moment this document was released. Changes may occur without notice.

## Trademarks

Bluetooth® is a registered trademark of Bluetooth SIG, Inc.

Windows is a trademark or registered trademark of Microsoft Corporation in the United States and/or other countries.

All other trademarks are trademarks of their respective owners.

## Apple - Legal Notice

iPhone, iPad are a trademark of Apple Inc., registered in the U.S. and other countries.

“Made for iPhone,” and “Made for iPad” mean that an electronic accessory has been designed to connect specifically to iPhone, or iPad, respectively, and has been certified by the developer to meet Apple performance standards.

Apple is not responsible for the operation of this device or its compliance with safety and regulatory standards.

Please note that the use of this accessory with iPhone or iPad may affect wireless performance.



## Regulatory Compliance

### ISO 11784 & 11785

This device complies with the standards set forward by the International Standardization Organization. Specifically, with standards:

11784: Radio frequency identification of animals -- Code Structure.

11785: Radio frequency identification of animals -- Technical Concept.

### FCC NQY-30012

### IC 4246A-30012

### CE Marking

# Table of Contents

<b>1</b>	<b><u><a href="#">Reader Overview</a></u></b>	<b>6</b>
1.1	<u><a href="#">Product Description</a></u>	6
1.2	<u><a href="#">Reader Front View Diagram</a></u>	7
1.3	<u><a href="#">Reader Back and Bottom View Diagram</a></u>	8
1.4	<u><a href="#">Reader Display Diagram</a></u>	9
1.5	<u><a href="#">Supplied Equipment</a></u>	10
1.6	<u><a href="#">Reader Care and Maintenance</a></u>	11
1.7	<u><a href="#">Updating Reader Firmware</a></u>	11
<b>2</b>	<b><u><a href="#">Getting Started</a></u></b>	<b>12</b>
2.1	<u><a href="#">Turning Reader On and Off</a></u>	12
2.2	<u><a href="#">Charging Reader</a></u>	13
2.2.1	<u><a href="#">Battery Symbols</a></u>	14
<b>3</b>	<b><u><a href="#">Configuring Reader</a></u></b>	<b>15</b>
3.1	<u><a href="#">General Settings</a></u>	15
3.1.1	<u><a href="#">General Settings Diagram Tree</a></u>	16
3.2	<u><a href="#">Memory Settings</a></u>	17
3.2.1	<u><a href="#">Memory Settings Diagram Tree</a></u>	19
3.3	<u><a href="#">Bluetooth Settings</a></u>	20
3.3.1	<u><a href="#">Bluetooth Settings Diagram Tree</a></u>	20
3.4	<u><a href="#">Reader Information</a></u>	21
<b>4</b>	<b><u><a href="#">Reading Tags</a></u></b>	<b>22</b>
4.1	<u><a href="#">Reading RFID Tags</a></u>	22
4.2	<u><a href="#">Testing Reader Performance</a></u>	22

---

<b>5</b>	<b><u><a href="#">Communicating with the Reader</a></u></b>	<b>23</b>
5.1	<u><a href="#">Connecting to PC via USB</a></u>	23
5.2	<u><a href="#">Connecting USB Flash Drive</a></u>	23
5.3	<u><a href="#">Connecting to PC via Bluetooth</a></u>	24
5.3.1	<u><a href="#">Bluetooth Operation</a></u>	24
5.3.2	<u><a href="#">Bluetooth Indicators</a></u>	25
<b>6</b>	<b><u><a href="#">Reader Commands</a></u></b>	<b>26</b>
6.1	<u><a href="#">General Commands</a></u>	26
6.2	<u><a href="#">Settings Commands</a></u>	27
6.3	<u><a href="#">Memory Commands</a></u>	27
6.4	<u><a href="#">Power Commands</a></u>	27
<b>7</b>	<b><u><a href="#">Reader Setting Values and Defaults</a></u></b>	<b>28</b>
<b>8</b>	<b><u><a href="#">Tag Transmission Format</a></u></b>	<b>29</b>
8.1	<u><a href="#">“Streamed” Data</a></u>	29
8.2	<u><a href="#">USB Drive Download</a></u>	30
8.3	<u><a href="#">Memory Download</a></u>	30
<b>9</b>	<b><u><a href="#">Reader Alarms</a></u></b>	<b>31</b>
<b>10</b>	<b><u><a href="#">Reader Technical Specifications</a></u></b>	<b>32</b>
<b>11</b>	<b><u><a href="#">Warranty</a></u></b>	<b>33</b>

---

# 1 Reader Overview

## 1.1 Product Description

The HPR Lite reader is a portable handheld radio frequency identification (RFID) PIT tag reader for intended use with animal tags. The HPR Lite reader has been designed specifically for use in fish and wildlife research applications.

The reader features:

- Rugged drop resistant and waterproof (IP67 rated) housing.
- Tag detection capabilities include: ISO 11784/11785 compliant FDX-B and HDX, FDX-B Fastag, FDX-B BioTherm13 temperature sensing, FDX-A (FECAVA), Avid Encrypted, Trovan and Unique Manchester coded tags.
- Memory for storage of over 50,000 tag IDs, each with a corresponding date/time stamp and temperature (if used with FDX-B BioTherm13 temperature sensing tags).
- Internal 7.2V lithium ion rechargeable battery pack.
- Backlit LCD high-contrast 38 mm x 38 mm screen.
- Visual, audible and vibrating indication of a tag detection.
- Bluetooth wireless communication.
- Micro USB wired communication/charging.

## 1.2 Reader Front View Diagram

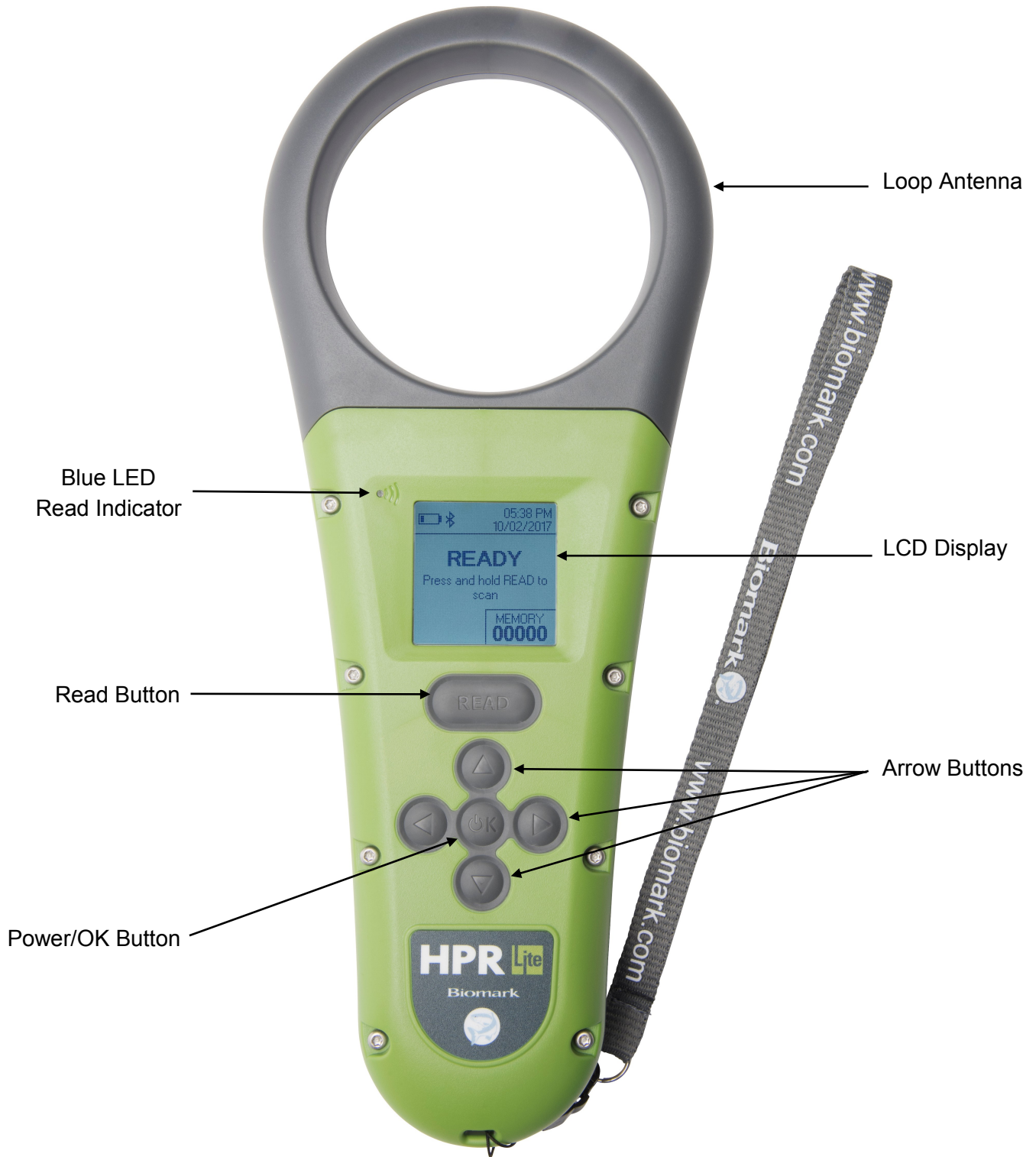

### 1.3 Reader Back and Bottom View Diagram





## 1.4 Reader Display Diagram

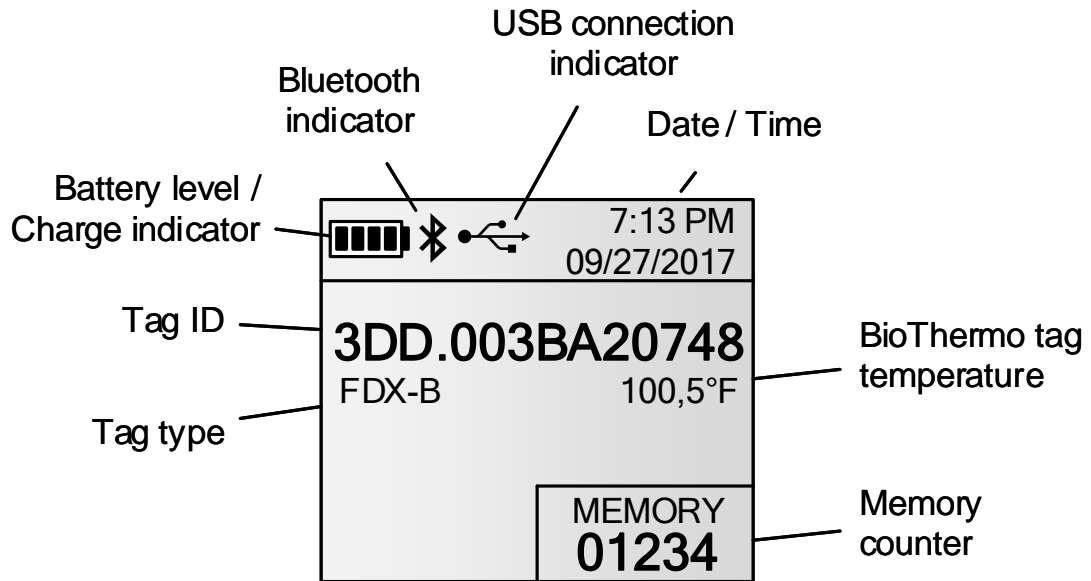

## 1.5 Supplied Equipment

The following items are included with the purchase of HPR Lite reader:

- HPR Lite reader.
- RFID FDX-B Test Tag fish-shaped keychain.
- Power Charger kit (Input: 100-240 V AC; 50-60 Hz, 0.5 A; Output: 5.0 V DC, 2.1 A), including 3 international plug adapters.
- Micro USB to USB cable, 61 cm (3 ft.) long.
- Micro USB OTG Flash drive adapter.
- Biomark hand strap.
- HPR Lite Quick Start Guide.
- Custom hard case.
- Biomark Tag Manager software (1 PC installation). See page 11, section 1.7 for details.

Please ensure you have received all of the above equipment upon receipt of your new reader.



## 1.6 Reader Care and Maintenance

While the HPR Lite reader has been designed to be as rugged and durable as possible, please observe the following points to ensure your reader provides many years of trouble free service:

- Fully charge the battery before first use of the reader or before putting the reader into storage.
- If the reader is exposed to salt water, rinse the entire unit with fresh water and dry it thoroughly before putting into storage.
- Clean and dry the reader before putting it back into its carry case.

The HPR Lite is waterproof up to 1 meter for 30 minutes (IP67 rated). **The reader was not designed or intended to be operated underwater or otherwise intentionally submerged.**

**NOTE:** Water cannot enter into the reader through the connector, but any moisture could damage the terminals in the Micro USB cable if inserted while wet.

**Do not try to access or replace the internal battery. Contact Biomark for battery replacement.**

**Risk of fire if battery is replaced by an incorrect type.**

## 1.7 Updating Reader Firmware

New or updated firmware may periodically become available for the HPR Lite reader. You can check Biomark's web site to see if an update is available. The easiest way to update the firmware is through the Biomark Tag Manager or BioTerm communication software. Biomark Tag Manager requires a product key to run, which is included with each purchase of the reader (1 PC installation only). Please contact the Customer Service Department at Biomark to obtain the key by calling (208) 275-0011 or emailing customerservice@biomark.com.

To check for availability of a firmware update or to download Biomark Tag Manager or BioTerm software please go to [https://www.biomark.com/help/firmware\\_applications/](https://www.biomark.com/help/firmware_applications/).

Please refer to corresponding software's User Manual, available at [https://www.biomark.com/help/manuals\\_instructions/](https://www.biomark.com/help/manuals_instructions/), for the reader's firmware update procedure.

Refer to section **5 Communicating with Reader** for more information on how to establish reader's communication with a PC.

**NOTE:** As a precaution, you should download all tag IDs contained in memory before initiating the update process. All settings may be reset to manufacturer default values during the update process, so it is recommended that you take a note of the present settings prior to updating the reader.

## 2 Getting Started

### 2.1 Turning Reader On and Off

The reader can be powered on by any of the following methods:

- Pressing and holding the OK button for 1 second.
- Connecting the reader to the included AC power supply or USB port of a PC.

Upon powering up, the reader will display a splash screen and emit a short beep. This screen will display the present firmware version in the bottom right corner. After approximately 1.5 seconds, the reader will display the main screen.



Screen during power up

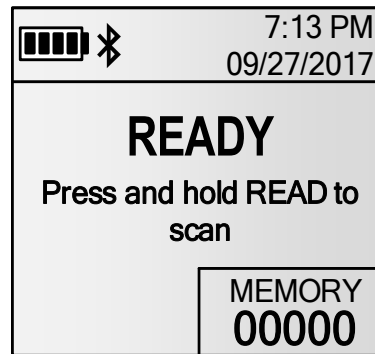

Main Screen

**NOTE:** Operating ambient temperature of the HPR Lite reader must be between  $-20^{\circ}\text{C}$  ( $-4^{\circ}\text{F}$ ) and  $+58^{\circ}\text{C}$  ( $+136.4^{\circ}\text{F}$ ) with relative humidity between 10% and 90%, non-condensing.

The reader can be powered off by any of the following methods:

- Pressing and holding the OK button while in main screen. After approximately one second a shutdown timer will appear. Continue holding the OK button until the reader sounds two beeps and shuts down. The count down can be aborted by releasing the OK button.

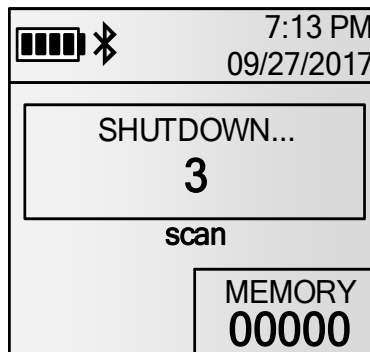

- The reader will automatically power off after certain period of inactivity. The inactivity time is user adjustable and by default is set to 180 seconds (3 minutes). Pressing any button will reset the timer.

The reader will stay powered on while:

- The reader is connected to the AC power supply or USB port of a PC.
- The reader is connected to a PC via Bluetooth in slave mode (remote device has established the connection). The reader will power off automatically after 60 minutes of inactivity.

## 2.2 Charging Reader

The reader has an internal 7.2V lithium ion re-chargeable battery.

To charge the battery, follow these steps:

- **Fast Charge:** Plug the Micro USB cable into the connector at the bottom of the reader, then plug the USB connector into the AC power supply. Charging using this method will take <6 hours with a healthy battery. **Multiple power plug adapters have been provided with the reader, please ensure you are using the correct adapter for your location.**
- **Slow Charge:** Plug the Micro USB connector of the cable into the connector at the bottom of the reader, then plug the USB connector into a USB port of a PC. Charging using this method will take ≤16 hours with a healthy battery.

**NOTE:** Water cannot enter into the reader through the connector, but any moisture could damage the terminals in the Micro USB cable if inserted while wet.

Ambient temperature during battery charging must be between 0°C (+32°F) and +40°C (+104°F) with relative humidity between 35% and 85%, non-condensing.

The HPR Lite reader is not intended to be operated while the battery is charging. Should the reader begin scanning while charging, the charge will be suspended and will restart after the scanning operation is finished.

Please be aware that when using the reader in environments below freezing temperature, the battery's ability to supply power will be reduced. This will reduce the reader's battery run-time and possibly the maximum usable RF transmit power resulting in a reduction of reader performance. Please ensure your reader is set to use power saving mode under these conditions to avoid excessively loading the battery. See page 15, section 3.1 for more details.

**Do not try to access or replace the internal battery. Contact Biomark for battery replacement.**





**Risk of fire if battery is replaced by an incorrect type.**

### 2.2.1 Battery Symbols

While charging, the battery icon becomes animated. The current level of charge is indicated by the location of the flashing bars. For example, if the battery is at 50%, only two bars will be animated.

The animation speed of each bar will change depending on the amount of charge the battery it is currently receiving.

**NOTE:** Charging is internally suspended during tag scanning but the charge icon continues to flash.

Symbol	Battery Charge Level
	80 - 100%
	50 - 80%
	20 - 50%
	10 - 20%
	0 - 10%

If the reader is powered on when the battery level is at or below 10%, the unit will display the message **Battery Low** and will sound three quick beeps.

When the battery voltage become critically low (0%), the reader will display the message **Battery Flat Powering down...**, will sound one long beep and will automatically shut down.

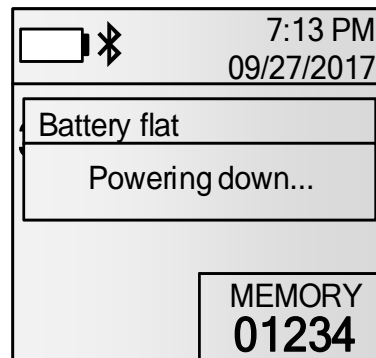
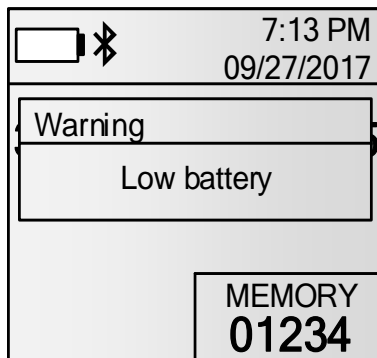

**NOTE:** If the battery level is critically low (0%), the reader will not power up.

## 3 Configuring Reader

The Main Menu can be accessed by briefly pressing down the OK button. From here, pressing the corresponding arrow key allows selecting the desired settings' sub-menu. When in a sub-menu, up and down arrow keys allow scrolling through settings; pressing OK key allows changing the selected setting. To exit a sub-menu back to the Main Menu press the left arrow key. To exit the Main Menu screen press the OK button.

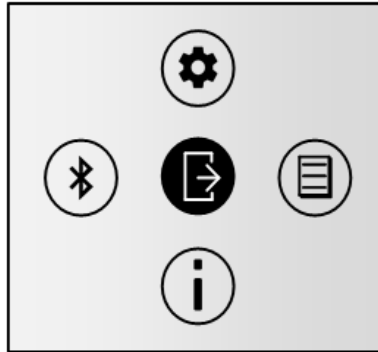

### 3.1 General Settings

Pressing the  (Up) key while in the Main Menu screen will display the General settings menu.

This menu provides access for managing the system settings of the reader.

Parameters that can be adjusted are:

- **Vibration** - Turns the internal vibration on or off. **The default for this setting is enabled.**
- **Beeper** - Turns the audible indicator on or off. The reader emits a beep for many different reasons, but when disabled all instances will be silent. **The default for this setting is enabled.**
- **Power Saving Mode** - When enabled, antenna power output will be reduced by 50% to increase battery life. Enabling this mode will also reduce reader performance by 15-25%. **The default for this setting is disabled.**
- **Tag format** - Switches between hexadecimal (e.g. 3DD.00075BCD15) or decimal (e.g. 989.000123456789) tag ID display. **The default for this setting is HEX.**
- **Temperature unit** - Switches between °C or °F tag temperature display (when FDX-B BioTherm13 temperature sensing tag is detected). **The default for this setting is °F.**
- **Date/Time** - Allows setting the reader's internal clock
- **Language** - Selects the language of the reader. Options are English, French, Spanish, and Portuguese. **The default for this setting is English.**
- **Load default settings** - Will reset all options back to the factory defaults. A confirmation window will appear asking to verify this action. If 'Yes' is pressed, the reader will automatically reset all settings. **Tag data stored in memory will not be erased.**

**NOTE:** More settings are available through reader's USB or Bluetooth connection to a PC.

### 3.1.1 General Settings Diagram Tree

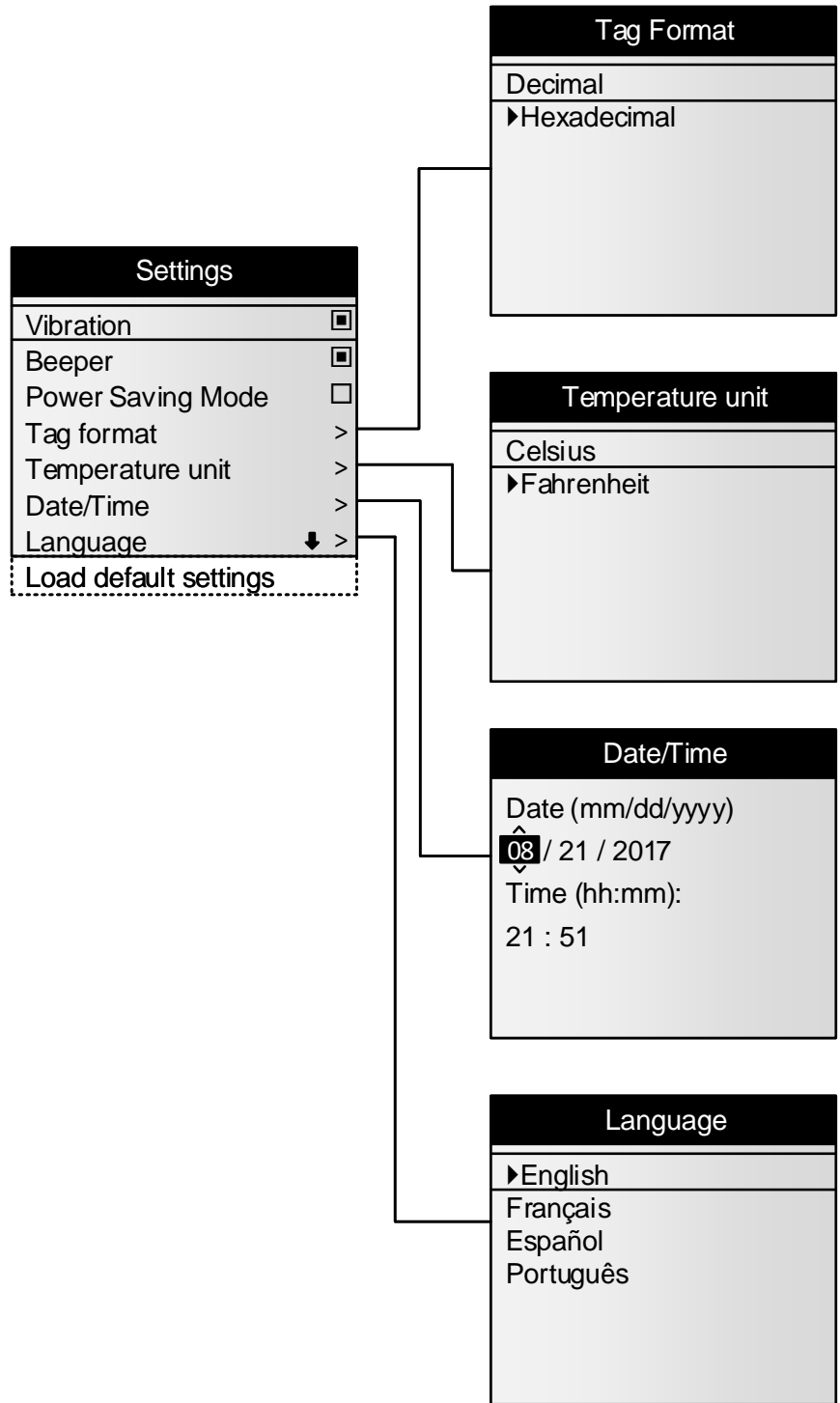



## 3.2 Memory Settings

Pressing the  (Right) key while in the Main Menu Screen will display the Memory settings menu.0

This menu allows you to access information within the reader's memory.

Parameters that can be adjusted are:

- **View tags** - Displays the tag IDs currently stored in the reader's memory from newest to oldest. The numbers in the parenthesis tell you which tag ID you are currently viewing out of the total number of tag IDs stored.
- **Storage mode** - Changes which detected tag IDs are stored in the memory. There are 3 possible options:
  - **Disabled** - Disables the HPR Lite's memory. Detected tag IDs will not be stored in the memory, but will still be transmitted via USB and Bluetooth connections. When disabled, the counter on the main screen is replaced with an '**OFF**' indication.

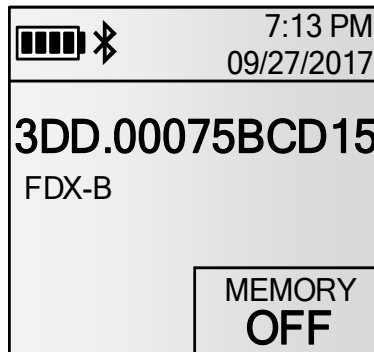

- **On All** - All detected tag IDs will be stored in the memory and transmitted via USB and Bluetooth connections. The memory counter on the main screen will increase after each detection.

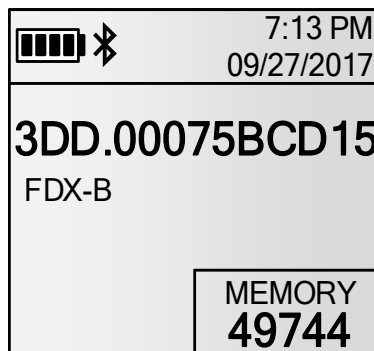

- **On Unique** - A tag ID is stored and transmitted via USB and Bluetooth connections only once when it is detected several times in a row. If another tag is detected after the first tag, and the first tag is detected again, it will be read and stored again. If the reader is powered off and on, the tag ID can be stored and transmitted again. **On Unique is the default Memory setting.** See examples on page 18.

Tags Detected	Stored in Memory
Read tag A	Yes
Read tag A	No
Read tag B	Yes
Read tag A	Yes
Read tag A	Yes
Read tag A	No
Read tag A	No
Read tag A	No
Read tag A	Yes
Read tag A	No
Reader shut down	
Reader powered up	
Read tag A	Yes
Read tag A	No

On Unique Memory Examples

- **Clear memory** - Deletes all stored tag IDs from the reader's memory. A confirmation window will appear asking to verify this action. If 'Yes' is pressed, the reader will perform the deletion.
- **USB Drive** - Exports entire memory content to a connected USB Flash Drive.

**NOTE:** Memory capacity is 50,000 tag IDs. When the memory reaches the 50,000 tag, the 50,001st ID will automatically replace the oldest record in the memory. In other words, the memory is circular and always contains the last detected 50,000 tag IDs.

When the 50,000th tag ID is written into the memory the following message is displayed:

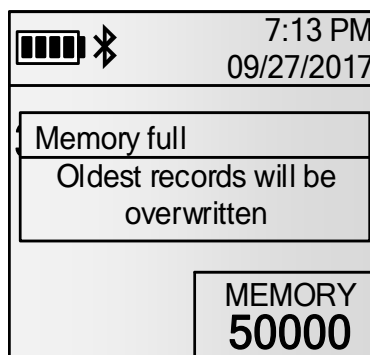

### 3.2.1 Memory Settings Diagram Tree

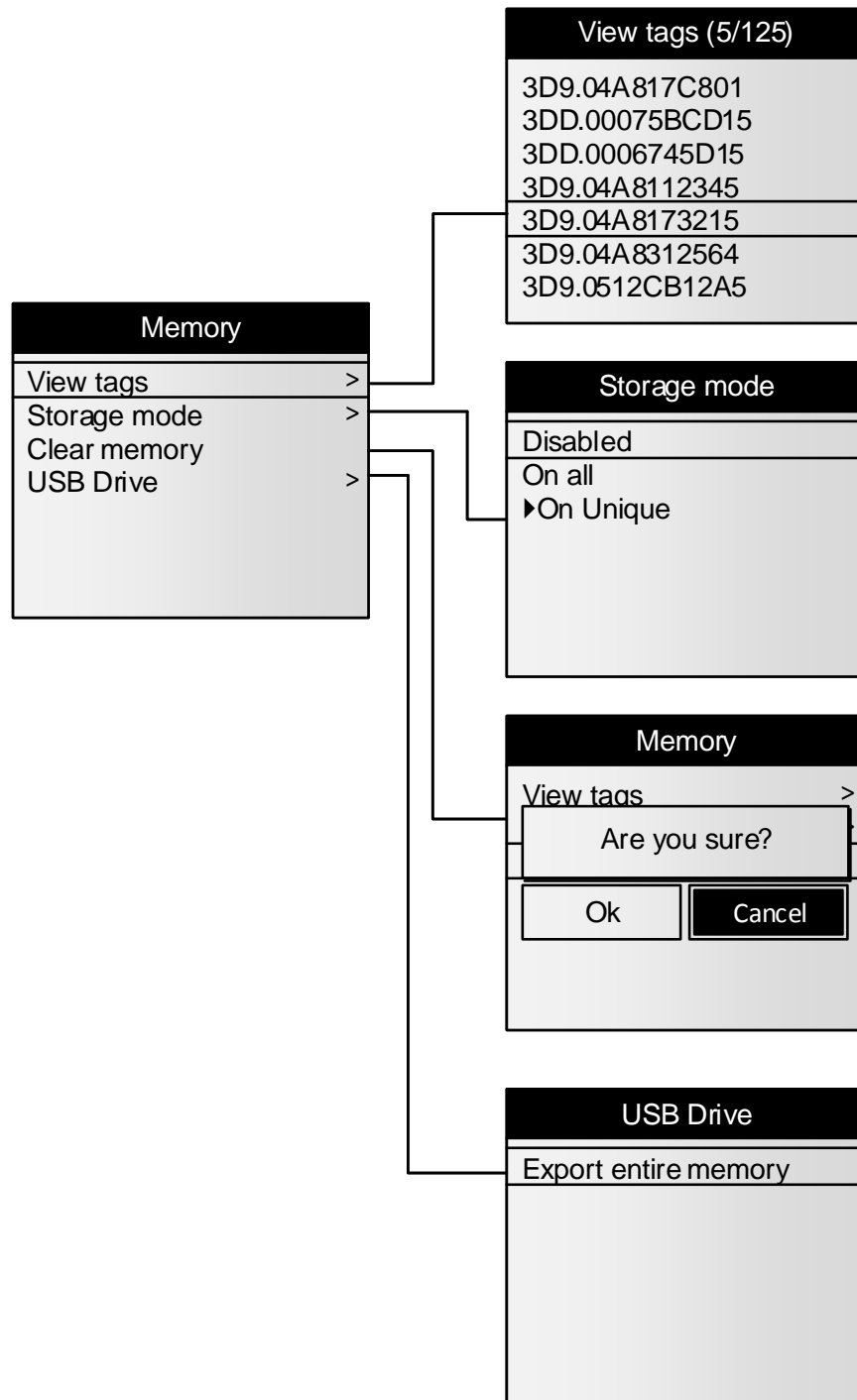

### 3.3 Bluetooth Settings

Pressing the  (Left) key while in the Main Menu Screen will display the Bluetooth settings menu.

This menu allows you to manage all available Bluetooth actions.

Parameters that can be adjusted are:

- **On/Off** - Enables or disables Bluetooth communication of the HPR Lite reader. **The default setting for this option is Enabled.**
- **Select device** - Allows you to switch the reader into Slave mode or scan for available Bluetooth devices in the vicinity to connect to. Establishing Bluetooth connection with any device from the list will switch the reader into Master mode. **The default for this option is Slave.**
- **Authentication** - Enables or disables SSP (Secured Simple Pairing). **The default setting for this option is Enabled. The default PIN is 1234.**
- **About** - Displays the reader's Bluetooth information.

#### 3.3.1 Bluetooth Settings Diagram Tree

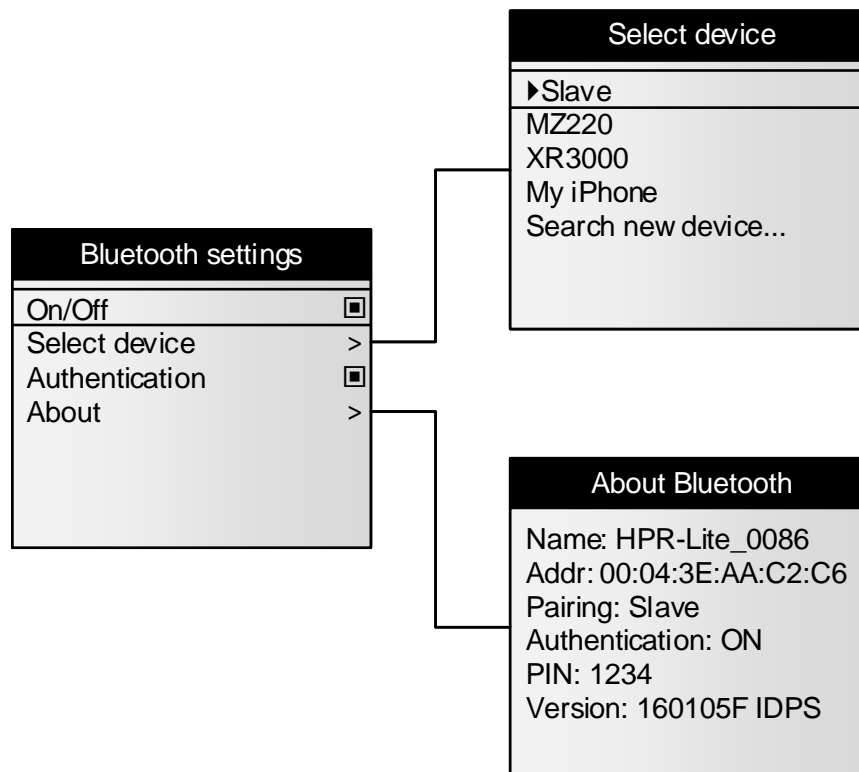

### 3.4 Reader Information

Pressing the  (down) key while in the Main Menu Screen will display the reader information menu. This menu allows you to view general reader information.

Displayed information includes:

- Reader name.
- Reader ID.
- Reader serial number.
- Reader firmware version.
- Reader part number (contains hardware / mechanical revision).
- Memory space used.
- Battery charge percentage.

Reader information
Name: HPR-Lite_0086
Reader ID: 01
S/N: DP0086
FW: 1.01.00 - Sep 25 2017
P/N: 30012-0A2
Memory used: 7%
Batt: 87%

## 4 Reading Tags

### 4.1 Reading RFID Tags

Upon starting up, the main screen of the HPR Lite will display the message **READY - Press and hold READ to scan**. Pressing and holding the READ button will put the reader in scan mode and will display **Reading...** on the main screen. The reader will remain in scan mode as long as the READ button is pressed or until a tag is read.

Bring the reader as close to the likely location of the PIT tag as possible and move slowly over it.

When a PIT tag is read the HPR Lite, depending on how its settings are configured, will flash the blue LED indicator once, generate a longer single beep and vibration, store the tag ID in the memory, exit scan mode, and display the tag ID on the main screen.

When the same tag is read once again the reader will quickly flash the blue LED indicator once, generate a shorter double beep and vibration, store tag ID in the memory, exit scan mode, and display the tag ID on the main screen. The reader's actions in this case also depend on its settings' configuration.

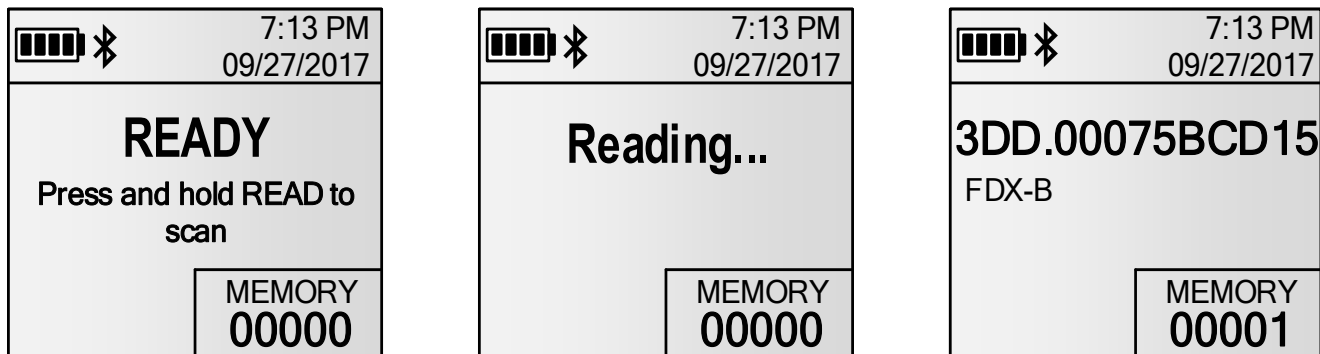

When the READ button is released and no tag has been read, the HPR Lite will generate three short beeps, exit scan mode, and display the message **No tag detected** then return to the last message that was on the main screen.

### 4.2 Testing Reader Performance

The supplied 12mm FDX-B PIT test tag fish keychain should be used to verify operation of the reader. While not in Power Saving mode, and the test tag located at the center of the reader's antenna loop, fish pointing into the loop, the tag should have a read range of approximately 20 cm (8 inches) from the center of the loop.

**NOTE:** The antenna and tag should not be placed on or near any metallic object while reading, as this will significantly reduce the tag read range.

## 5 Communicating with the Reader

Connecting the HPR Lite to a PC via USB or Bluetooth allows downloading tag IDs stored in the reader's memory and adjusting additional settings that are not available via the reader menus. Please refer to section **6 Reader Commands** for more information. It is possible to communicate with the reader using any terminal program on a PC.

Biomark recommends using **BioTerm** or **Tag Manager** programs to securely monitor, maintain, and update the HPR Lite reader. **BioTerm** is a communication and device managing program used to connect a Biomark reader to a computer and perform communication and configuration tasks or update the reader's firmware. **Tag Manager** software is a program designed to quickly and easily access tag data on a Biomark reader. The program allows a user to download the data directly into Microsoft Excel, plus other useful functions, such as convenient graphical user interface for configuring the reader and the reader's automatic firmware verification and update. While **BioTerm** is a free software available to all Biomark customers, **Tag Manager** program requires an activation key to be used. One (1) copy of **Tag Manager** is included with the purchase of your reader. When you open the software for the first time your PC will generate a computer ID number. Please call +1 (208) 275-0011 or email [customerservice@biomark.com](mailto:customerservice@biomark.com) with this ID number to receive your activation code. For more information about these products or to download them, please visit [www.biomark.com](http://www.biomark.com).

### 5.1 Connecting to PC via USB

When the reader is connected to a computer via the USB cable, it will automatically turn on and beep once (if not already on and if beeper is enabled), vibrate for a short time (if vibration is enabled) and the USB icon (  ) will be displayed on the screen. Once connected, Biomark Tag Manager or BioTerm software can be used to access the reader's memory or to configure its settings.

The reader's internal battery will be slowly charging while it is connected to a PC via USB. The rate at which the battery will be charging depends on the PC's USB port specifications.

**NOTE:** The HPR Lite USB driver needs to be installed on the PC in order for the connection to be established successfully. The driver should be installed automatically with installation of Biomark Tag Manager software or upon connection of the reader to a USB port of the PC. If the driver did not install automatically the USB icon will not be displayed on the reader's screen and the connection will not get established. In this case the driver needs to be installed manually. It can be found at [https://www.biomark.com/help/firmware\\_applications/](https://www.biomark.com/help/firmware_applications/).

### 5.2 Connecting USB Flash Drive

A USB flash drive can be connected to the HPR Lite using a micro USB OTG adapter for transferring the content of reader's memory.



Once the adapter is plugged into the reader, the reader will automatically attempt to connect to the drive. Once it is connected, the HPR Lite will automatically create a new CSV file and copy only those tag IDs from the reader's memory that had never been transferred onto a Flash drive. The entire memory content can be transferred onto a Flash drive manually.

All files are automatically created in a dedicated folder named **HPR-Lite**. The name of the CSV file has the following format:

**tag\_[ID]\_[COUNTER].csv**

where:

- ID is the Reader ID (2 HEX characters).
- COUNTER starts from 01 and is automatically incremented based on the existing files detected on the USB Flash drive.

Example: **G:\HPR-Lite>tag\_A0\_01.csv**

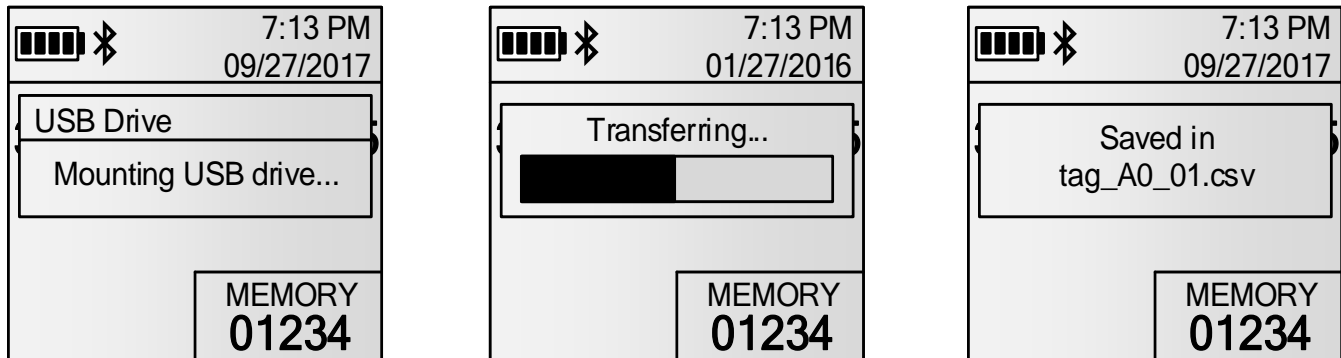

If the USB drive detection fails, the following screen will appear and allow you to retry or cancel the detection:

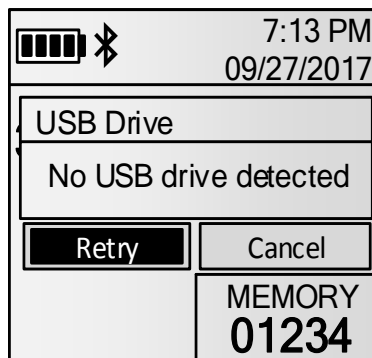

## 5.3 Connecting to PC via Bluetooth

### 5.3.1 Bluetooth Operation

By default, the Bluetooth module is discoverable and connectable (Slave mode or device).

Bluetooth authentication is enabled. When enabled, Bluetooth uses SSP (Secured Simple Pairing) to pair with another remote device. The pairing will be done transparently for the user.

**NOTE:** When Bluetooth authentication is disabled, the default PIN code is 1234. This may be required with older Bluetooth devices.

If the reader must connect by itself to a remote device, the menu allows to search for the devices in the vicinity and pair to the desired device. Once a device is selected, the reader will operate as Master and will constantly try to connect to the associated device. In the Master mode, the reader is not connectable.

**NOTE:** The Connection to an iPhone or an iPad requires the Master mode.



The reader keeps in memory the last 4 devices it connected to for easy re-connection.



### 5.3.2 Bluetooth Indicators

The table below explains the meaning of the Bluetooth symbol seen on the HPR Lite’s top bar of the screen.

Icon	State
Blinking	Disconnected (Visible and connectable, Slave mode)
Fixed	Connected (Slave mode)
Blinking	Disconnected, tries to initiate connection with the selected device (Master mode)
Fixed	Connected (Master mode)

**NOTE:** When the Bluetooth module is disabled, the Bluetooth icon is not displayed.

When a Bluetooth connection is successfully established, the reader will sound a single beep and will display **Bluetooth connected**. When the Bluetooth connection is closed the reader will sound three (3) longer beeps and will display the message **Bluetooth disconnected**.

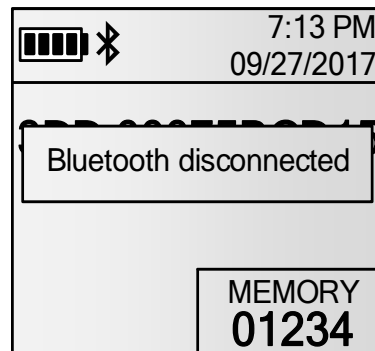
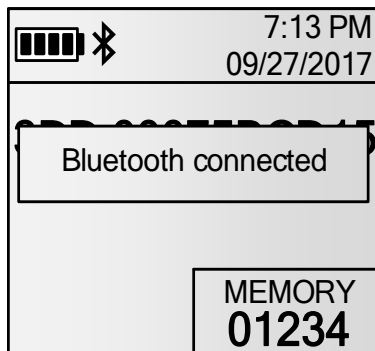

## 6 Reader Commands

**ASCII protocol is used for communication between a HPR Lite reader and a PC.** ASCII (American Standard Code for Information Interchange) is a character-encoding scheme based on the ordering of the English alphabet. This is the simplest communications protocol. It transmits only ASCII characters and uses ASCII control codes. It implies little or no error checking.

The HPR Lite commands are made up of three or more characters followed by a carriage return (Enter key). Generally, the first three letters designate the command and the remaining letters/digits designate the command's parameter. The commands are not case sensitive. Space needs to be inserted between the command and its parameter. The backspace key can be used to correct an improper command. The responses to the commands confirming the requested action or setting parameter change are sent back by the reader.

The following is a list of the available commands.

### 6.1 General Commands

Command	Description	Example Result
RFV	Report Firmware Version	1.01
RHV	Report Hardware Version	A2
RID	Report Reader ID	01
RUT	Report Unit Type	HPR-Lite
RDS <mm/dd/yyyy>	Set Reader Date (mm/dd/yyyy) "." can be used as a separator	Date changed
RTS <hh:mm:ss>	Set Reader Time (hh:mm:ss, 24-hour) "." can be used as a separator	Time changed
RDT	Report Reader Date (mm/dd/yyyy) and Time (hh:mm:ss, 24-hour)	<10/13/2012> <07:58:00>
RDP	Reset to Factory Default Parameters	Are you sure? y/n Default settings loaded
?	List All Commands	

## 6.2 Settings Commands

Command	Description	Example Result
SLA	List All Present Settings	1. Reader ID = 01 2. Unit Name = HPR-Lite_P0156 ... 17. Bluetooth Password = 1234
ST <id>	Report Present Value of a Setting	st 1 1. Reader ID = 01
S <id> <value>	Change Value of a Setting	s 1 ff 1. Reader ID = FF

## 6.3 Memory Commands

Command	Description	Example Result
FDA	Download Entire Memory File	12-13-2016 11:46:28 01 TAG * 3DD.003BA20748 12-13-2016 11:53:45 01 TAG * TR 00-06D1-86E7 ... Entire memory file downloaded
FEA	Erase Entire Memory File	Are you sure? y/n Entire memory file erased
FCD	Copy Entire Memory File to USB Drive	Entire memory file copied to USB drive: tag_01_00.csv

## 6.4 Power Commands

Command	Description	Example Result
POW	Report Power Information	Battery: 68% 7.81 V
RAR	Reset Reader	OK

## 7 Reader Setting Values and Defaults

Setting Number	Setting Name	Description	Factory Default Value	Configurable Values
1	Reader ID	Defines the reader ID (2 HEX characters)	01	2 HEX characters 00-FF
2	Unit Name	Defines the unit name that is used as Bluetooth discoverable name	"HPR-Lite_xxxx" ("xxxx" is the reader)	Up to 16 alphanumeric characters
3	Language	Defines the reader interface language	1 (English)	1=English 2=French 3=Spanish 4=Portuguese
4	Timestamp Format	Defines the date format for timestamping	2 (MDY)	1=DMY 2=MDY 3=ISO 8601
5	Tag Format	Defines the tag ID display format	1 (HEX)	1=DEC 2=HEX
6	Temperature Unit	Defines the BioTherm13 tag temperature display unit	2 (F)	1="C" 2="F"
7	Power Saving Mode	Reduces antenna power output by 50%	No	0=No 1=Yes
8	Auto Shutdown Time	Defines the time before the reader automatically powers off	180	0-7200 (seconds)
9	Backlight Time	Defines the time before the backlight is turned off	20	1-7200 (seconds)
10	Storage Mode	Defines the tag IDs storage mode	3 (On Unique)	1=No storage 2=On All 3=On Unique
11	Vibration Enable	Enables/Disables the vibration	Yes	0=No 1=Yes
12	Beeper Enable	Enables/Disables the beeper	Yes	0=No 1=Yes
13	Bluetooth Enable	Enables/Disables the Bluetooth	Yes	0=No 1=Yes
14	Bluetooth Authentication	Enables/Disables the Bluetooth Authentication	Yes	0=No 1=Yes
15	Bluetooth Connection Mode	Defines whether the reader operates in Slave (discoverable and connectable) or Master mode (automatically connect to a known device)	1 (Slave)	1=Slave 2=Master
16	Bluetooth Remote Address	Defines the Bluetooth address to connect in Master mode to	00:00:00:00:00:00	6 bytes
17	Bluetooth Password	Defines the PIN code for the Bluetooth Authentication	1234	Up to 16 alphanumeric characters

## 8 Tag Transmission Format

Tag information is transmitted in the following format:

**[TIMESTAMP] [READER ID] TAG [\*] [TAG NUMBER] [TAG TEMPERATURE]**

Where:

- **TIMESTAMP** is the date and time of the detection. Date can be represented in 3 different formats depending on the present configuration of the reader. Ex: 12-13-2016 11:46:28.
- **READER ID** is the detecting reader ID (2 HEX characters). Ex: A0.
- **“\*”** is only transmitted when tag ID is downloaded from reader’s memory via Bluetooth or USB communication connection.
- **TAG NUMBER** is the detected tag’s unique ID number. It can be represented in DEC or HEX format depending on the configuration of the reader.
  - ◇ **FDX-B / HDX / Fastag:** 900.074001615913 or 384.113AD70C29
  - ◇ **FDX-A:** 0A115A4D4D
  - ◇ **TROVAN:** TR 00-0724-CEE1
  - ◇ **MANCHESTER:** 0000187828868 or 000B320A84
  - ◇ **AVID Encrypted:** AVID\*068\*834\*609
- **TAG TEMPERATURE** is the temperature reading of the detected FDX-B BioTherm13 tag (BIO13.THERM.03V1).

### 8.1 “Streamed” Data

Each time a new tag is scanned, its ID number is transmitted to both communication links (Bluetooth and USB):

12-13-2016 11:46:28 A0 TAG 3DD.003BA20748

If the same tag is scanned multiple times in a row it’s ID will be transmitted every time it is scanned if Storage Mode is set to 1 (No storage) or 2 (On All). If Storage Mode is set to 3 (On Unique) the ID will only be transmitted once until a different tag is scanned.

## 8.2 USB Drive Download

When a tag ID is downloaded from reader's memory onto USB Flash drive, it is written in a CSV file as a single data string:

```
12-13-2016 11:46:28 A0 TAG 3DD.003BA20748
```

Once the CSV file is opened in Microsoft Excel, data can be sorted in columns using the space delimiter as following:

	A	B	C	D	E
1	12-13-2016	11:46:28	A0	TAG	3DD.003BA20748
2	12-13-2016	11:46:28	A0	TAG	3DD.003BA20749
3	12-13-2016	11:46:28	A0	TAG	3DD.003BA20758
4	12-13-2016	11:46:28	A0	TAG	3DD.003BA20765
5					

## 8.3 Memory Download

When a tag ID is downloaded from reader's memory via Bluetooth or USB communication connection, a "\*" is added to each line to differentiate it from "streamed" data:

```
12-13-2016 11:46:28 A0 TAG * 3DD.003BA20748
```

## 9 Reader Alarms

Whenever a fault event occurs with the reader, an alarm message is displayed and 3 beeps are emitted to make you aware of the condition.

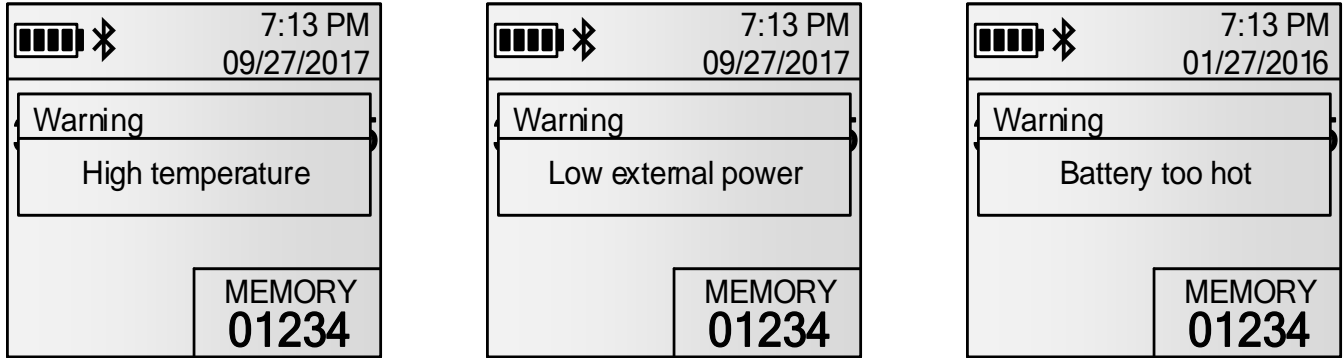

The following table contains the list of possible alarms and their detailed description:

Alarm	Problem
High temperature	The reader internal temperature is over 80°C. <b>The reader will shut down automatically.</b>
Bad battery detected	The reader detected a bad battery and the battery must be replaced. Please contact Biomark customer service for this procedure. <b>Do not attempt to replace the battery yourself as this can damage the reader and will void any existing warranty.</b>
Battery too hot	The battery temperature is over 40°C. <b>Charging is internally suspended.</b>
Battery too cold	The battery temperature is below 0°C. <b>Charging is internally suspended.</b>
Low external power	USB voltage is below 4.5 V. <b>Charging is internally suspended.</b>
Low battery	The battery voltage is below 10%.
Battery flat	The battery voltage is 0% and it must be charged. <b>The reader will shut down automatically.</b>

## 10 Reader Technical Specifications

Specification	Description
Operating Frequencies	134.2 kHz
Tags Detection	FDX-B, HDX, FDX-B Fastag, FDX-B BioTherm13, FDX-A, Avid Encrypted, Trovan, Unique (Manchester Encoded)
Antenna Design	Internal
Antenna Power Adjustable	Yes
External Power Options	5 V DC
Internal Battery Type	Li-ion (Rechargeable)
Tag ID Memory	50,000 IDs
Date & Time Stamp Option	Yes
Communication Options	USB, Bluetooth, USB Flash Drive
GPS Capable	No
Automatic Power Shut-off	Programmable
Continuous Operation Capability	No
Display Type	FSTN B&W, 3.8 cm x 3.8 cm LCD
Display Backlight	Yes
Operating Temperature Range	-20°C – 58°C with relative humidity between 10% and 90%, non-
Storage Temperature Range	-20°C – 58°C with relative humidity between 10% and 90%, non-
Waterproof	Yes (IP67)
Shockproof	Yes (per EN 60068-2)
Dimensions	31 x 12.4 x 4 cm (12.2 x 4.9 x 1.6 in)
Weight	450 g (0.99 lbs)
Regulatory Compliance	ISO 11784 & 11785, FCC, IC, CE



## **11 Warranty**

The HPR Lite reader is warranted against defects in materials and workmanship, under normal use and service for one (1) year from the day of shipment.

This warranty will not apply if adjustment, repair or parts replacement is required because of accident, neglect, damage during transportation or causes other than ordinary use.

Manufacturer's sole responsibility under this warranty shall be at its option, to either repair or replace any product which fails during the warranty period. In no event shall Manufacturer be liable for any indirect or consequential damages or loss of profit.