

Contents

Safety Instructions	3
HANDSET Controls - Location and Function	7
BASE UNIT Controls - Location and Function	11
Getting Started	15
Desk Mounting	17
Wall Mounting	18
Cordless Telephone Operation	19
Preparing for Use	19
Turning the BASE UNIT Ringer ON/OFF	19
Receiving Calls	20
Placing Calls	21
HANDSET Redial Feature	21
Storing Numbers	22
Recalling Stored Numbers from Memory	23
Answering System Operation	24
Setting the Day/Time Stamp	24
Recording Your Outgoing Messages	25
Turning the Answering System ON/OFF	26
Setting to Answer Calls	26
Setting to Announce Only	26
Setting Not to Answer Calls	27



Screening Incoming Calls	27
Message Alert	27
Setting Ring Select	27
Recording a Memo	27
Playing Back of Messages/Memos	28
Saving Messages	29
Erasing Messages	29
When Memory is Full	29
Remote Control Operation	30
Remote Operation through the HANDSET	30
Remote Operation through Tone Telephone	31
Remote Access Codes	31
Changing of Remote Access Codes	31
Using the Remote Voice Instruction Code	32
Security	33
Recharging the Battery Pack	34
Changing the Battery Pack	35
Problem Solving	36
Technical Information	38
FCC Requirements	39
Warranty Information	41
Wall Mount Template	44

IMPORTANT SAFETY INSTRUCTIONS

To reduce the risk of fire, electric shock and/or injury, always follow these basic safety precautions when using your cordless telephone equipment.

1. Read and understand all instructions.
2. Follow all warnings and instructions marked on the telephone.
3. Unplug this telephone from the wall outlet before cleaning or replacing batteries. Do not use liquid cleaners or aerosol cleaners. Use a damp cloth for cleaning. If necessary, use only a mild soap.
4. Do not use this telephone near a bathtub, kitchen sink, wash bowl, laundry tub, swimming pool, in a wet basement, or anywhere else where there is water.
5. Do not place this telephone on an unstable cart, stand or table. A fall could cause serious damage to the phone.
6. This product should never be placed near or over a radiator or heat register. This product should not be placed in a built-in installation unless proper ventilation is provided.
7. Operate this telephone only with the correct electrical voltage shown on the label or in the Owner's Manual. If you are not sure of the voltage in your home, consult your dealer or local power company.
8. Do not allow anything to rest on the power cord. Do not install the phone where people will walk on the cord.
9. Do not overload wall outlets and extension cords. This can increase the risk of fire or electric shock.
10. Never push objects of any kind through slots in the phone. They could touch dangerous voltage points or short out parts that could result in a risk of fire or electric shock. Never spill liquid of any kind on the telephone.
11. To reduce the risk of electric shock, do not take this telephone apart. When service or repair work is required on this telephone, take it to a qualified service representative. Opening or removing covers may expose you to dangerous voltage or other risks. Incorrect re-assembly can cause electric shock when the appliance is used.
12. Unplug this telephone from the wall outlet and consult a qualified service representative in any of the following situations:
 - A. When the power supply cord is frayed or damaged.



- B. If liquid has been spilled into the telephone.
 - C. If the product has been exposed to rain or water.
 - D. If the telephone does not operate normally by following the operating instructions. Adjust only those controls that are covered by the operating instructions. Improper adjustment of other controls may result in damage and will often require extensive work by a qualified technician to restore the telephone to normal operation.
 - E. If the telephone has been dropped or the case has been damaged.
 - F. If the telephone exhibits a distinct change in performance.
13. Avoid using a telephone (other than a cordless type) during an electrical storm. There may be a remote risk of electric shock from lightning.
 14. Do not use the telephone to report a gas leak in the vicinity of the leak.
 15. Never install telephone wiring during a lightning storm.
 16. Never install telephone jacks in wet locations unless the jack is specifically designed for wet locations.
 17. Never touch uninsulated telephone wires or terminals unless the telephone line has been disconnected at the network interface.
 18. Use caution when installing or modifying telephone lines.

Battery Safety

CAUTION:

To reduce the risk of fire or personal injury, read and follow these instructions:

1. Use only the following type and size of battery pack:
 - a. **For HANDSET**
 - Cordless Telephone Battery Pack
 - 3.6V, 600mAh
 - U.S. Electronics Inc.
 - Ni-Cd Battery Pack: model B650
 - (See page 34 for ordering information.)



Safety Instructions

b. For BASE UNIT

1.5V Carbon Zinc or Alkaline AAA size Battery

2. Do not dispose of the battery(ies) in fire. They may explode. Check with local codes for possible special disposal instructions.
3. Do not open or mutilate the battery(ies). Released electrolyte is corrosive and may cause damage to the eyes or skin. It may be toxic if swallowed.
4. Exercise care in handling batteries to prevent shorting the battery with conducting materials such as bracelets and keys. The battery or conductor may overheat and cause burns.

FOR BASE UNIT BATTERIES:

5. Do not attempt to recharge the battery(ies) identified for use with this product. The batteries may leak corrosive electrolyte or explode.
6. Do not attempt to rejuvenate the battery(ies) identified for use with this product by heating them. Sudden release of the battery electrolyte may occur causing burns or irritation to eyes or skin.
7. When replacing batteries, all batteries should be replaced at the same time. Mixing fresh and discharged batteries could increase internal cell pressure and rupture the discharged battery(ies). (Applies to products employing more than one separately replaceable primary battery).
8. When inserting batteries into this product, the proper polarity or direction must be observed. Reverse insertion of batteries can cause charging, which may result in leakage or explosion. (Applies to product employing more than one separately replaceable primary battery).
9. Remove the batteries from this product if the product will not be used for a long period of time (several months or more) since during this time the battery could leak in the product.
10. Discard "dead" batteries as soon as possible since "dead" batteries are more likely to leak in a product.

Safety Instructions



11. Do not store this product, or the battery(ies) identified for use with this product, in high temperature areas. Batteries that are stored in a freezer or refrigerator for the purpose of extending shelf life should be protected from condensation during storage and defrosting. Batteries should be stabilized at room temperature prior to use after cold storage.

FOR HANDSET BATTERY

12. Change the battery pack provided with or identified for use with this product only in accordance with the instructions and limitations specified in this manual.

SAVE THESE INSTRUCTIONS

HANDSET Controls

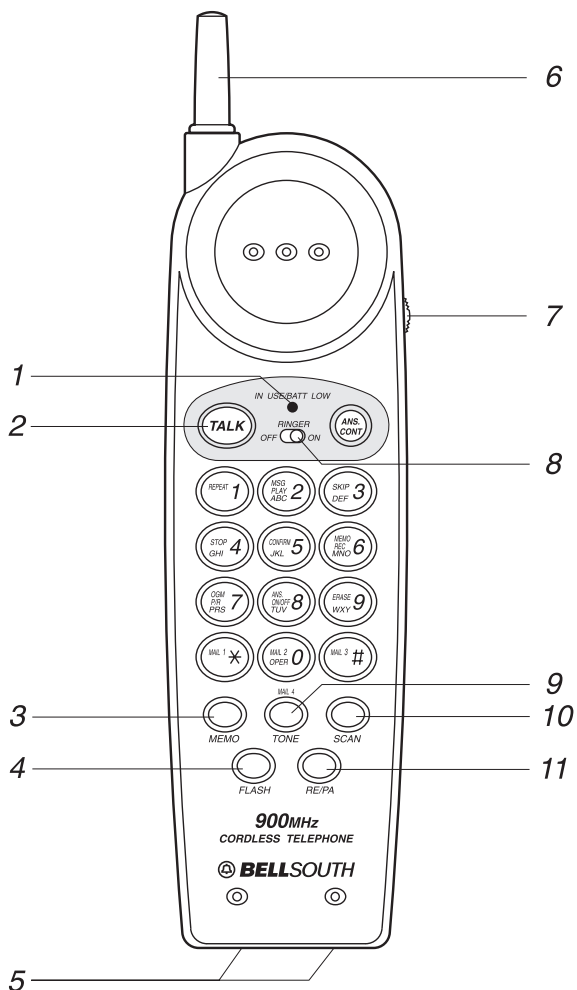



HANDSET Controls

1. **In Use/Batt Low Indicator:** Lights when the HANDSET is in TALK mode. Blinks when battery power is low. (See page 34 for details.)
2. **Talk Button:** Press to answer an incoming call or to place a call. Press to end a call. Press twice to stop paging.
3. **Memo Button:** Press to store phone numbers in memory or to call a number you have stored previously.
4. **Flash Button:** Press to answer a call if you have Call Waiting.
5. **Charge Contacts:** For charging the battery pack in the HANDSET. We recommend cleaning periodically with a damp cloth.
6. **ANTENNA**
7. **Volume Control (HI, LOW) Switch:** Select the volume level (HI, LOW).
8. **Ringer Switch:** Turn to OFF position to disengage the ringer on the HANDSET.
9. **Tone Button:** Press to change the dialing mode temporarily from Pulse to Tone for Rotary Service Users. (Press once before entering numbers to access the answering system or electronic banking services, etc.)
10. **Scan Button:** Press to change the operating channel when you hear interference.
11. **Redial/Pause (RE/PA) Button:** Press to redial the last number called. Press to insert a pause while dialing. (You will need the **RE/PA** button to dial numbers which use an alternative long distance access code.)

IMPORTANT

In order to get maximum life from the HANDSET battery pack, be sure to charge the HANDSET for 12 hours before initial use.

HANDSET Controls

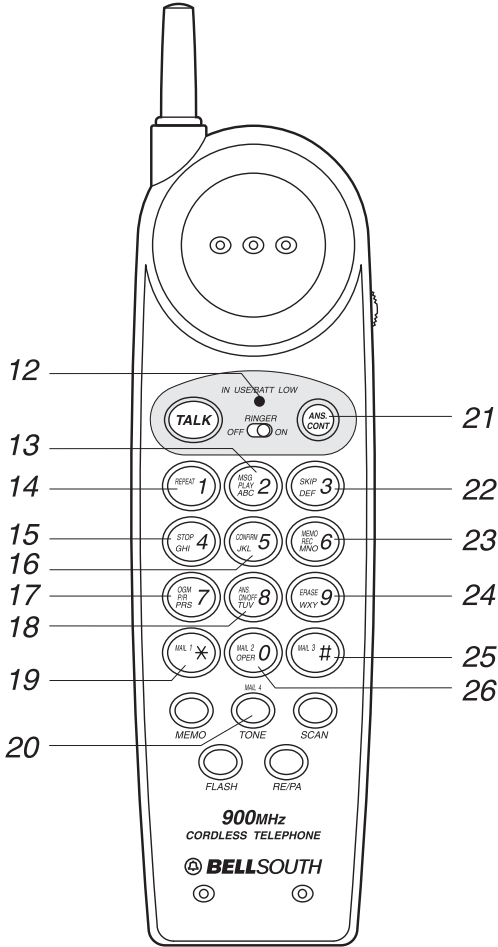



HANDSET Controls - Answering System

12. **Answering Control Indicator:** Blinks when answering functions are controlled by the HANDSET.
13. **Incoming Message (ICM) Play Button:** Press to play messages.
14. **Repeat Button:** Press to repeat the message being played or a previous message.
15. **Stop Button:** Press to stop current activity.
16. **Confirm Button:** Press to play continuously. This prevents the Remote function from being disengaged when no Instruction Code is entered within 3 minutes.
17. **Outgoing Messages (OGM) Play/Record Button:** Press to play or record OGM.
18. **Answer ON/OFF Button:** Press to activate or deactivate answer function.
19. **Mailbox 1 Button:** Press to activate functions for Mailbox 1.
20. **Mailbox 4 Button:** Press to activate functions for Mailbox 4.
21. **Answering Control Button:** Press to activate remote control.
22. **Skip Button:** Press to skip to the next message.
23. **Memo Record Button:** Press to record memo messages.
24. **Erase Button:** Press to erase messages.
25. **Mailbox 3 Button:** Press to activate functions for Mailbox 3.
26. **Mailbox 2 Button:** Press to activate functions for Mailbox 2.

BASE UNIT Controls

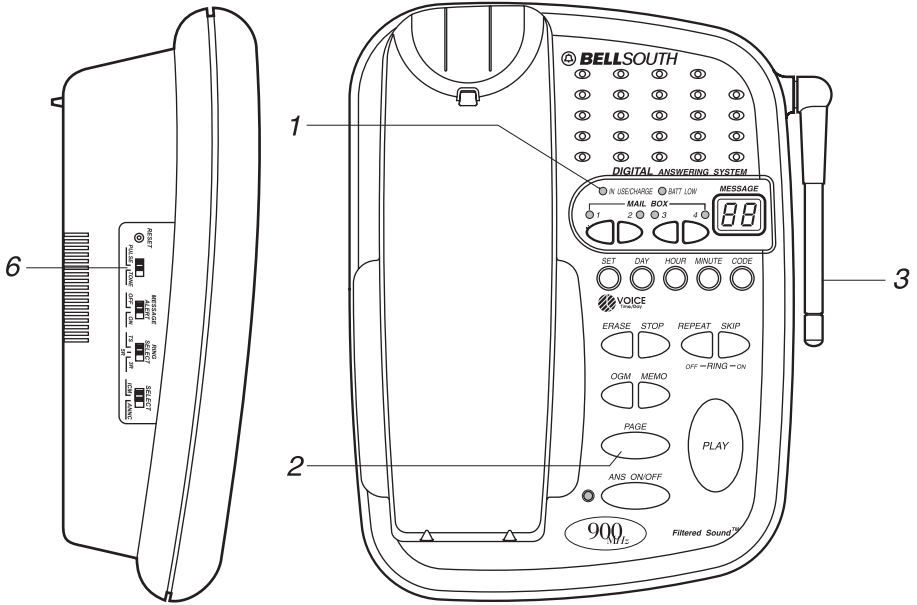
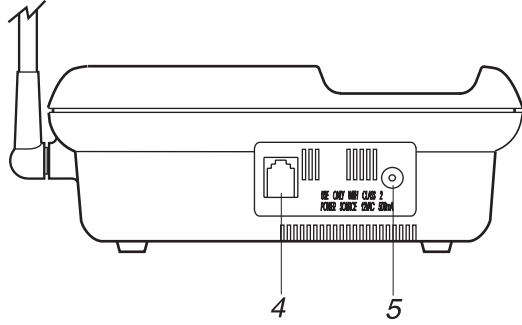



BASE UNIT Controls - Cordless Telephone

- 1. In Use/Charge Indicator:** Lights when line is in use. Lights when HANDSET is placed on the BASE UNIT for charging.
- 2. Page Button:** Press to page the HANDSET. Press again to stop.
- 3. ANTENNA:** Raise for the best reception.
- 4. Modular Line Jack:** Accepts line cord to make connection with modular type telephone outlet.
- 5. Power In Jack:** Accepts 12VAC Power from AC ADAPTOR.
- 6. Tone/Pulse Select Switch**

BASE UNIT Controls

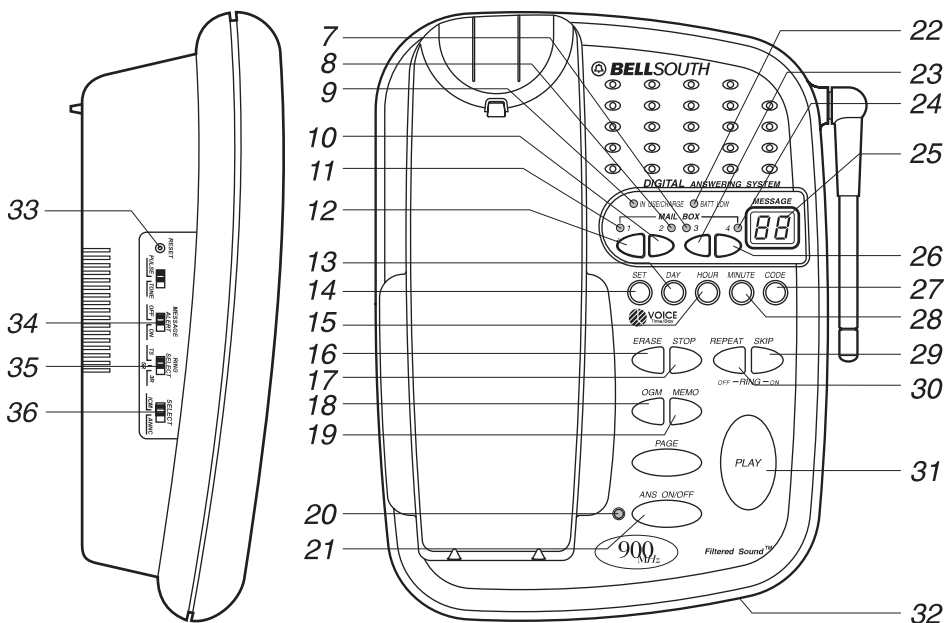

BASE UNIT Controls - Answering System

- 7. Mailbox 3 Indicator:** Lights to indicate the presence of message(s) and blinks to indicate Mailbox 3 is active and ready to operate.
- 8. Mailbox 2 Indicator:** Lights to indicate the presence of message(s) and blinks to indicate Mailbox 2 is active and ready to operate.
- 9. Answer Control Indicator:** Blinks when answering function is controlled by the HANDSET.
- 10. Mailbox 2 Button:** Press to activate functions for Mailbox 2.
- 11. Mailbox 1 Indicator:** Lights to indicate the presence of message(s) and blinks to indicate Mailbox 1 is active and ready to operate.
- 12. Mailbox 1 Button:** Press to activate functions for Mailbox 1.
- 13. Day Button:** Press to set the day during day setting or press to set the first digit of the access code during code setting.
- 14. Set Button:** Used for setting/checking the day and time.
- 15. Hour Button:** Press to set the hour during time setting, or press to set the second digit of the access code during code setting.
- 16. Erase Button:** Press to erase messages.
- 17. Stop Button:** Press to pause playback of memos/messages or to stop current activity.



18. **Outgoing Message (OGM) Button:** Press to play/record an OGM.
19. **Memo Button:** Press to record memo messages.
20. **Answer Function ON/OFF Indicator:** Indicates whether answer function is ON/OFF.
21. **Answer Function ON/OFF Button:** Press to activate or deactivate answer function.
22. **Battery Low Indicator:** Lights when backup battery power is low.
23. **Mailbox 3 Button:** Press to activate functions for Mailbox 3.
24. **Mailbox 4 Indicator:** Lights to indicate the presence of message(s) and blinks to indicate Mailbox 4 is active and ready to operate.
25. **Message Display:** Indicates the number of memos/messages received, status of the system.
ER - Erasing *0153* - No. of memos/messages *OP* - OGM is playing
RO - Announce Only *FU* - Memory is full *PA* - Pause
26. **Mailbox 4 Button:** Press to activate functions for Mailbox 4.
27. **Code Button:** Press to set the 3-digit access code for remote operation.
28. **Minute Button:** Press to set minute during time setting or press to set the third digit of the access code during code setting.
29. **Skip Button:** Press to skip messages. Press and hold down to turn ON the BASE UNIT incoming call ringer sound.
30. **Repeat Button:** Press to repeat messages. Press and hold down to turn OFF the BASE UNIT incoming call ringer sound.
31. **Play Button:** Press to play messages.
32. **Volume Control Switch:** Adjusts speaker volume.
33. **Reset Button:** Press to reset the system and clear all recordings.
34. **Message ALERT:** Switch ON to generate a "beep" sound every 18 seconds when new messages have been received.
35. **Ring Select Switch:** To select the number of rings before the Answering System answers a call.
3R - System answers call on the third ring.
5R - System answers call on the fifth ring.
TS (TOLL Saver) - System answers on the third ring only if you have new messages. Otherwise, the system will answer on the fifth ring.
36. **Announce Only / Incoming Message Switch:**
ICM - System records the incoming messages.
ANNC - System plays your announcement and then hangs up without recording messages.

Connecting Your Phone

This section is a **reference guide** in connecting your cordless telephone for proper operation.

1. Carefully remove your cordless telephone from its shipping carton. If there is any visible damage, do not attempt to operate this equipment. Return it to the place of purchase.
2. Check to be sure you have all items that come with this cordless telephone system. You should have a **HANDSET**, **BASE UNIT**, **AC ADAPTOR**, **TELEPHONE LINE CORD**, **SHORT TELEPHONE LINE CORD**, **WALL MOUNT BRACKET** and **OWNER'S MANUAL**.



HANDSET

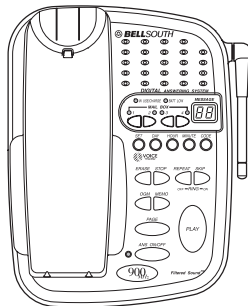

BASE UNIT

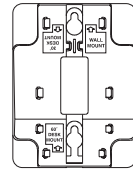

WALL MOUNT BRACKET

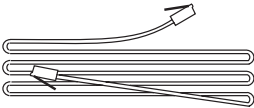

TELEPHONE LINE CORD



SHORT TELEPHONE LINE CORD

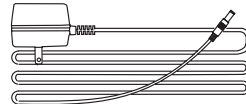

AC ADAPTOR

3. Install batteries which will be used as backup power to retain memory in case of power failure.

- A. Unscrew and open the Battery Cover located on the bottom of the BASE UNIT.
- B. Place 4 AAA size Batteries (1.5 volt) into the compartment, paying attention to the polarity shown in the compartment.
- C. Close the Battery Cover and screw back.

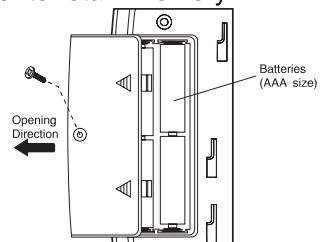

4. Insert one plug of the telephone line cord into the house telephone jack and the other end into the telephone line jack on the back of the BASE UNIT. (If you have an older 4-prong telephone jack, you will need an RJ-11C TELEPHONE JACK ADAPTOR. This adaptor is available at the same place you purchased your telephone.)

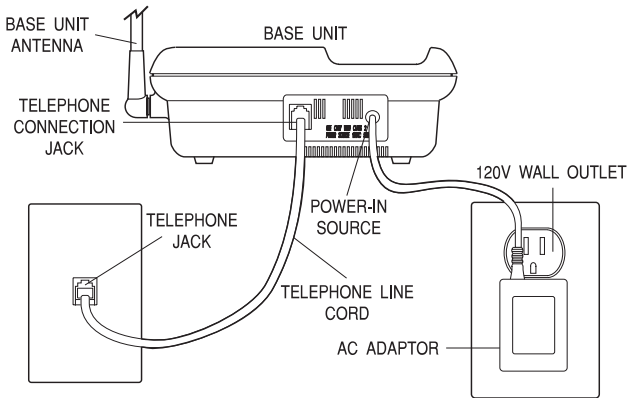

5. Insert the small plug on the end of the AC ADAPTOR into the POWER-IN connection jack on the back of the BASE UNIT.
6. Plug the AC ADAPTOR (output:12VAC, 500mA) into a 120V AC wall outlet.
7. Set the date and time of the BASE UNIT. (See page 24 for details.)
8. Raise the ANTENNA on the BASE UNIT for the best reception.
9. We recommend not placing this unit next to appliances. Doing so may cause interference.
10. TONE/PULSE select switch:
 - A. If your home is equipped with a tone dialing system, set the TONE/PULSE select switch to the TONE position.
 - B. If you have a rotary dialing system, set TONE/PULSE select switch to the PULSE position.
 - C. If you are not sure which system you have, set the TONE/PULSE select switch to the TONE position. Press the **TALK** button on the HANDSET to get a dial tone, and press any button on the keypad except the zero. If the dial tone continues, it means that you do not have tone dialing service. Press the **TALK** button on the HANDSET to hang up. Set the TONE/PULSE select switch to the PULSE mode and then try again.
11. **Before initial use, charge the HANDSET for 12 hours.**

***You are now ready to use your new
BellSouth Cordless Telephone.***

Desk Mounting

One of the special features of your telephone is the unique design of the MOUNTING BRACKET which can hold your phone at an angle of 30° and 60° when desk mounting. There are three positions to choose from:

1. NORMAL POSITION (Mounting Bracket not required)

For Normal Position, as shown in Figure 1, place the BASE UNIT in any desired but suitable location. To charge the batteries, place the HANDSET in its charge cradle.

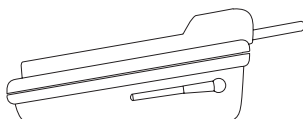

FIGURE 1

2. 30° POSITION (See Figure 2)

With the back of the BASE UNIT facing up, insert the hooks of the MOUNTING BRACKET (marked "30° DESK MOUNT") into the matching slots of the BASE UNIT (as shown in Figure 3). Then slide the MOUNTING BRACKET into place as indicated by the arrow.

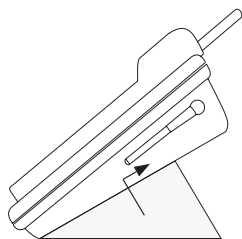

FIGURE 2

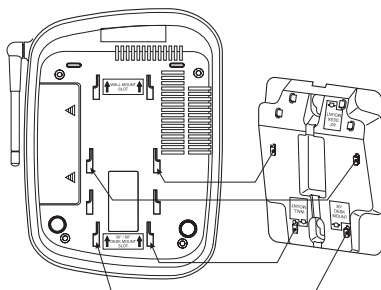

FIGURE 3

3. 60° POSITION (See Figure 4)

With the back of the BASE UNIT facing up, insert the hooks of the MOUNTING BRACKET (marked "60° DESK MOUNT") into the matching slots of the BASE UNIT (as shown in Figure 5). Then slide the MOUNTING BRACKET into place as indicated by the arrow.

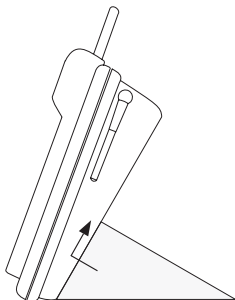

FIGURE 4

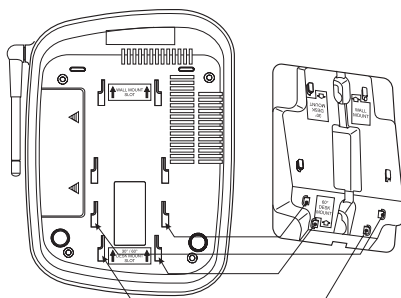
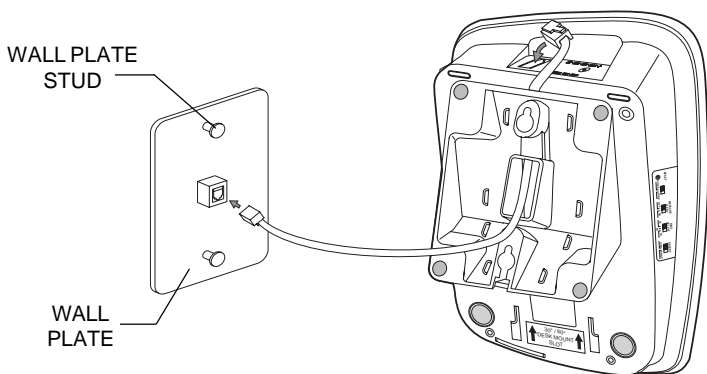
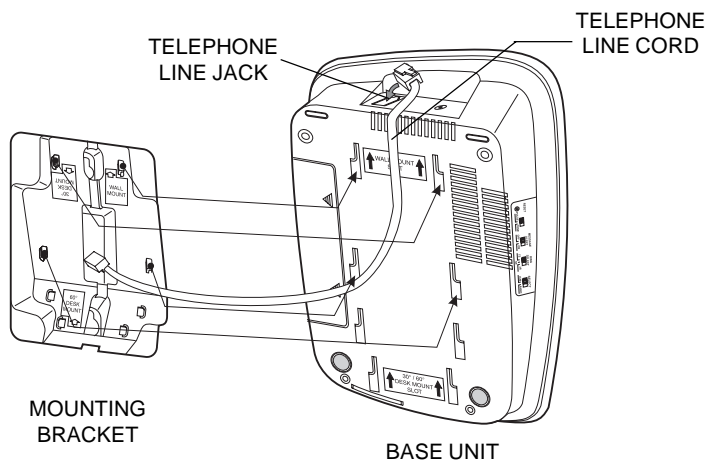

FIGURE 5

Wall Mounting

You may choose to mount the BASE UNIT of your cordless telephone on a wall.

1. With the back of the BASE UNIT facing up, connect the SHORT TELEPHONE LINE CORD to the telephone line jack.
2. Insert the SHORT TELEPHONE LINE CORD through the hole of the MOUNTING BRACKET.
3. Insert the hooks of the MOUNTING BRACKET (marked "WALL MOUNT") into the matching slots of the BASE UNIT (as shown below). Then slide the MOUNTING BRACKET into place as indicated by the arrow. Plug the free end of the SHORT TELEPHONE LINE CORD into the MODULAR WALL JACK.
4. Align the upper keyhole on the MOUNTING BRACKET with the upper STUD of the wall plate, so that the opening end of the MOUNTING BRACKET matches the lower stud, then pull the BASE UNIT down until securely seated.



Cordless Telephone Operation

Preparing for Use

Before you can use your cordless telephone, you must charge the HANDSET for at least 12 hours. Failure to do so will require recharging of the battery pack more often.

1. Place the HANDSET on the BASE UNIT for at least 12 hours.
2. After 12 hours, remove the HANDSET from the BASE UNIT.
3. **RAISE THE ANTENNA FOR BEST RECEPTION.**

Before you can use your cordless telephone, you must charge the HANDSET for 12 hours. Failure to do so will require more frequent charging of the battery pack. See page 34 for more information on the battery pack.

NOTE:

If you are far away from the BASE UNIT, the HANDSET emits beep sound (every 5 seconds) to warn you that the background noise level is too high for proper communication between HANDSET and the BASE UNIT. When you hear this sound, you should move closer to the BASE UNIT to reduce the noise level. Otherwise, the call will **automatically cut off**.

Turning the BASE UNIT Ringer ON/OFF

1. Press and hold down the **SKIP** button until a confirmation "ON" is heard. The Ringer is activated. The BASE UNIT will ring while receiving an incoming call.
2. Press and hold down the **REPEAT** button until a confirmation "OFF" is heard. The Ringer is deactivated. The BASE UNIT will not ring while receiving an incoming call.

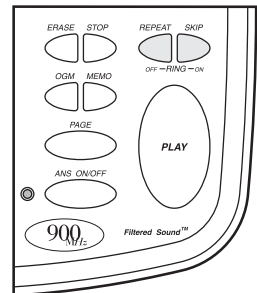



Receiving Calls

1. When the phone rings, lift the HANDSET.
The BASE UNIT IN USE indicator will light up.
2. Start your conversation.
3. To end your conversation, either press the **TALK** button or place the HANDSET on the BASE UNIT. When the HANDSET is placed on the BASE UNIT charge cradle, the automatic STANDBY feature is then activated.

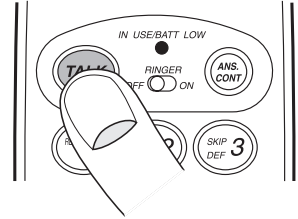

Receiving Calls with the HANDSET off the BASE UNIT

1. When the phone rings, press the **TALK** button. The IN USE indicator will light up.
2. Start your conversation.
3. To end your conversation, either press the **TALK** button or place the HANDSET on the BASE UNIT. If the HANDSET is placed on the BASE UNIT charge cradle, the automatic STANDBY feature is then activated.

NOTE:

Once the HANDSET is fully charged, it is operable for approximately 6 hours of continuous talk use; approximately 5 days when the HANDSET is left off the BASE UNIT in STANDBY mode with the RINGER SWITCH in the "ON" position, depending on frequency of use.

IMPORTANT

The AC ADAPTOR must always be plugged into an electrical outlet.

Cordless Telephone Operation

Placing Calls

1. Press the **TALK** button, the IN USE indicator will light up.
2. Listen for a dial tone.
3. Dial the phone number.
4. When finished with your call, press the **TALK** button again. The IN USE indicator will turn off.

HANDSET Redial Feature

1. If you get a busy tone, press the **TALK** button to hang up.
2. Press the **TALK** button again.
3. Listen for a dial tone.
4. Press the **RE/PA** button. This will automatically redial the last telephone number you called.

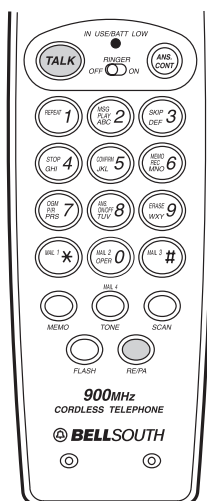

IMPORTANT

When you hear interference, press the **SCAN** button to change the operating channel.



Storing Numbers

1. Be sure the BASE UNIT IN USE indicator is OFF and the HANDSET is in STANDBY mode (See special features section.)
2. Press the **MEMO** button.
3. Dial the number you want to store.
4. Press the **MEMO** button again.
5. Press the index number (0-9) where you want to store that number.
6. Write the name of the person you will be calling with that number next to the index number on the telephone number label.
7. Repeat for other telephone numbers.

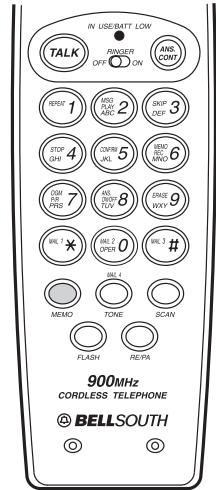

EXAMPLE: To store the number 555-1212 under the index number 1 on the keypad:

- | | |
|---|------------------------------------|
| 1 - Press the MEMO button. | 4 - Press 1 on the keypad. |
| 2 - Dial 555-1212. | 5 - You have stored 555-1212 under |
| 3 - Press the MEMO button again. | key 1 on the keypad. |

A total of 10 telephone numbers can be programmed in memory.

IMPORTANT: The maximum number of digits that can be stored for any phone number is 16 in PULSE or TONE mode. The maximum number of digits for mixed (Tone and Pulse in combination) dialing is 15. If you are using a switchboard system to access an outside line (such as an 8 or 9), press the **MEMO** button RE/PA to store a pause.

Recalling Stored Numbers from Memory

1. Press the **TALK** button.
2. Press the **MEMO** button.
3. Press the index number for the number you have stored. The stored number will be dialed automatically.

EXAMPLE: To recall number 555-1212 stored under key 1 on the keypad:

- Press the **TALK** button.
- Press the **MEMO** button.
- Dial 1.

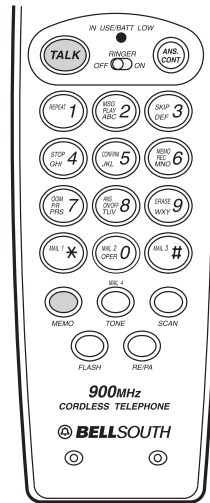

IMPORTANT

To obtain the best reception,
be sure to raise the BASE UNIT antenna.



Setting the Day / Time Stamp

1. Press and hold down the **SET** button until you hear the announcement "Please enter the day and time." Afterwhich, enter the current day and time.
2. **Day Setting**
Press and hold down the **DAY** button. The corresponding number of the day mentioned will be displayed and announced. Release the button when the desired day is mentioned.
3. **Hour Setting**
Press and hold down the **HOUR** button. The corresponding hour mentioned will be displayed and announced. Release the button when the desired hour is mentioned.
4. **Minute Setting**
Press and hold down the **MINUTE** button. The corresponding minute mentioned will be displayed and announced. Release the button when the desired minute is mentioned.

Press the **SET** button to confirm the selected day and time. The system will announce the set day and time.

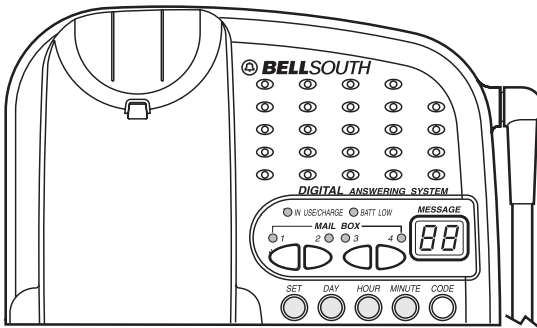

Recording Your Outgoing Messages

Your Answering System provides one primary mailbox and four individual mailboxes (1, 2, 3, 4) which can receive their own incoming messages. Before using your Answering System, it is suggested that you record an Outgoing Message (OGM). This is the announcement callers will hear when the system answers a call.

A pre-recorded system announcement "Hello, please leave a message after the tone." is made available if you choose not to record your own outgoing message.

A. Recording your OGM in Primary Mailbox

1. Press and hold down the **OGM** button to record your message.
2. Begin speaking right after you hear "Please begin speaking after the tone." Do not release the button until you have completed your message. Length of OGM less than 3 seconds will not be accepted.
3. Release the **OGM** button one second after your message is completed. Your recorded message will be played after releasing the button.

If you wish to change your OGM, repeat steps 1 through 3.

It is recommended that you record an OGM on your primary mailbox instructing a caller to leave an incoming message on one of the four mailboxes. If the caller is using a Tone telephone, this will enable the caller to record an incoming message directly on one of the four mailboxes by dialing "11" for mailbox 1, "22" for mailbox 2, "33" for mailbox 3, "44" for mailbox 4.

Example of Primary OGM: "Hello, please leave a message after the tone, or if you are using a Tone telephone, please Dial 11 for Mary, Dial 22 for Tommy, Dial 33 for Peter, Dial 44 for Samson".

Note: To check your OGM, press the **OGM** button. If you did not place any OGM, it will announce "You have no OGM."

B. Recording your OGM for Individual Mailbox 1, 2, 3 or 4

1. Press a mailbox button, the corresponding mailbox indicator will blink.
2. Press and hold down the **OGM** button to record your message.
3. Begin speaking right after you hear "Please begin speaking after the tone." Do not release the button until you have completed your message. Length of OGM less than 3 seconds will not be accepted.
4. Release the **OGM** button one second after your message is completed. Your recorded message will be played after releasing the button.

If you wish to change your OGM, repeat steps 1 through 4.



Note: To check your OGM in a mailbox, press a mailbox button and then press the **OGM** button. If you have no OGM in a mailbox, it will announce "You have no OGM, mailbox X". Once a mailbox is activated, the corresponding light blinks slowly to indicate mailbox is actively ready to perform various functions. You have 10 seconds to carry out the desired function by pressing the appropriate button. Otherwise, the system will automatically switch back to the primary mailbox. To switch immediately back to the primary mailbox, simply press the **STOP** button while a mailbox light is blinking.

Turning the Answering System ON/OFF

1. Press the **ANS. ON/OFF** button to turn ON the system. You will hear the announcing of "Answer functions are ON."
2. Press the **ANS. ON/OFF** button again will turn OFF the Answering System and the statement "Answer functions are OFF" will be announced.

Setting to Answer Calls

The ANSWER ON/OFF indicator must be ON for the system to answer calls. Depending on the setting of the ANNC/ICM switch, the system will either hang up after your announcement (ANNC) or begin to record your caller's messages (ICM). After the caller leaves a message, the time and day will be stamped at the end of each recorded message. The message is stored in memory and the message display shows the total number of messages currently stored.

Note: Messages are limited to a maximum of 3 minutes. If the message is more than 3 minutes, the system beeps three times and hangs up; or if the system's memory runs out, the system announces "Sorry, memory is full" and hangs up.

Setting to Announce Only

1. Set the ANNC/ICM select switch to ANNC.
2. Press and hold down the **OGM** button to record your announcement.
3. Begin speaking right after you hear "Please begin speaking after the tone".
Do not release button until you have completed your message. Length of OGM less than 3 seconds will not be accepted.
4. Release the **OGM** button one second after your announcement is completed, the message display shows "AO".
During ANNC (Announce) mode, your system answers incoming calls with your recorded announcement but will not record any incoming messages.

Note: If you have not recorded any announcement, even if the switch is set to ANNC mode, the system will automatically operate in ICM mode and will record all incoming messages.

Setting Not to Answer Calls

1. Press the **ANS. ON/OFF** button to turn OFF the answer function.
2. The ANSWER ON/OFF indicator should be OFF.
Once turned OFF, the answer function will answer only on the tenth ring, allowing you to turn the system ON from a remote location.

Screening Incoming Calls

The system allows you to listen to a caller leaving a message.

Once the system starts answering a call, either press the **ANS.CONT** button for listening only; system will record continuously or press the **TALK** button for conversation; system will stop recording.

Message Alert

When the message alert switch is "ON", the unit will generate a beep sound every 18 seconds when a new message is recorded. If you do not want to hear the beep, set the switch to "OFF".

Setting Ring Select

To choose the number of times the phone rings before the system answers, set the Ring Select Switch to 3R, 5R or TS (Toll Saver)

- Set to 3R** - System answers call on the third ring.
- Set to 5R** - System answers call on the fifth ring.
- Set to TS** - Use "Toll Saver" (TS) when you will be calling long distance or from a pay phone to check for messages. The system answers after third rings only if you have messages waiting. If there are no messages, the phone will answer on the fifth ring. You can then hang up on the fourth ring to avoid paying for the call.

Recording a Memo

A. To record a memo in Primary Mailbox

1. Press and hold down the **MEMO** button to record your memo.
2. Begin speaking right after you hear the tone. Do not release the button until you have completed your memo.
3. Release the **MEMO** button one second after your memo is completed. The system advances the message count automatically before the actual message recording. Length of message less than 3 seconds will not be counted. Day and time are automatically stamped at the end of the message.



B. To record a memo in individual Mailbox (1, 2, 3, 4)

1. Press a mailbox button, the corresponding mailbox indicator will blink.
2. Press and hold down the **MEMO** button to record your memo.
3. Begin speaking right after you hear the tone. Do not release the button until you have completed your memo.
4. Release the **MEMO** button once your memo is completed.
The system advances the message count automatically before the actual message recording. Length of message less than 3 seconds will not be counted. Day and time are automatically stamped at the end of the message.

Playing Back of Messages/Memos

1. To play messages/memos in primary mailbox.

Press the **PLAY** button, the system will play all NEW messages/memos. Press the **PLAY** button again, the system will play all messages from the first message to the recently recorded one.

2. To play messages/memos in individual mailbox (1, 2, 3, 4).

Press a mailbox button, the corresponding mailbox indicator starts to blink, then press the **PLAY** button. The system will play all NEW messages/memos. Press the **PLAY** button again, the system will play all messages/memos from the first message to the recently recorded one.

Note: Mailbox light ON indicates the existence of message(s).

3. To interrupt a message.

Press the **STOP** button once while playing a message. To continue playing the message where you stopped, press the **PLAY** button.

4. To repeat a message/memo.

Press the **REPEAT** button while playing a message. The system moves back to the beginning of the current message being played.

5. To skip message/memo.

Press the **SKIP** button once. The system stops playing, moves to the next message/memo and resumes playback. The system advances one message/memo each time you press the **SKIP** button.

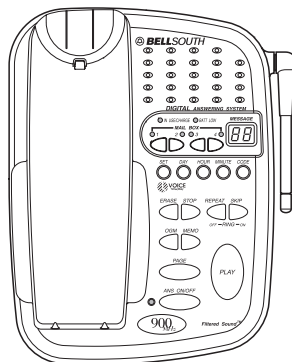

Saving Messages

The system saves your messages automatically. After playing back all your messages, the system announces "End of messages" and the total number of messages stored in memory will be indicated in the Message Display.

NOTE: System has a total memory capacity of 15 minutes which can store up to 63 messages (OGM/ICM/MEMO). If the recorded messages contains high background noise, the total recording capacity of the unit will be less than 15 minutes.

Erasing Messages

1. To erase all messages in primary mailbox

Press and hold down the **ERASE** button until you hear the announcement "Erasing all messages."

2. To erase all messages in individual mailbox (1, 2, 3, 4)

If you want to erase all messages in a mailbox, activate the desired mailbox then press and hold down the **ERASE** button until you hear the announcement of "Erasing all messages, Mailbox X".

3. To erase selected messages/memos

While the unwanted message is playing, press the **ERASE** button. The system announces erasure of the selected message/memo, and the message display shows the symbol of "EA". Numeric order of the remaining messages will be rearranged.

When Memory is Full

When memory is full, the ANSWER ON/OFF indicator will be automatically turned OFF. If no memory is available for messages, the system will answer after 10 rings and the statement "Sorry, memory is full" will be announced. The system answers after 10 rings to allow you to access to your Answering System via remote control but will be turned OFF again after 10 seconds if the caller does not enter the access code. (Refer to Remote Control Operation on page 30.)



Remote Control Operation

The Answering System can be operated through the HANDSET or away from your home through a Tone telephone.

Remote Operation through the HANDSET

You can operate your Answering System via remote control using the HANDSET.

1. Press the **ANS.CONT** button at STANDBY mode, to activate remote control function.
2. Press the corresponding number of the function you wish to activate.
 - A. Press "2" to play messages.
 - B. While playing messages, press "1" to repeat or "3" to skip.
 - C. Press "4" to stop playing messages and go to the primary mailbox.
 - D. Press "5" to play continuously. See NOTE below since maximum time for a remote control operation is 3 minutes.
 - E. Press "6" to record memo messages.
Press "6" again after your memo is completed.
 - F. Press "7" to play your OGM.
Press "77" to change your OGM.
Press "7" again to stop taking your OGM.
 - G. Press "9" to erase messages being played.
Press "99" to erase all messages in mailbox.
 - H. Press "8" to activate or deactivate the answering function.
 - I. Press " * " to activate the remote operation of Mailbox 1.
 - J. Press " 0 " to activate the remote operation of Mailbox 2.
 - K. Press " # " to activate the remote operation of Mailbox 3.
 - L. Press "TONE" to activate the remote operation of Mailbox 4.

NOTE: After the remote control function is activated, instruction code must be entered within 3 minutes. If not, the HANDSET will beep for 10 seconds and then terminate the remote control operation. While the HANDSET is beeping, press 5 (confirm) to continue remote control function.

3. Press the **ANS.CONT** button to deactivate the remote control function or place the HANDSET on the BASE UNIT.

Remote Operation through Tone Telephone

You can use many system features when you are away from home. To protect your privacy, most features can be used only after you enter the three-digit Remote Access Code.

Remote Access Codes

The Remote Access Codes are preset at factory as shown below. You can use the preset codes or choose your own.

Primary Mailbox	:	999
Mailbox 1	:	555
Mailbox 2	:	666
Mailbox 3	:	777
Mailbox 4	:	888

NOTE: If AC power fails and you have no backup battery installed or the backup battery is in low power, the Remote Access Codes return to factory preset codes.

Changing of Remote Access Codes

All digits of Remote Access Codes are the combination of numbers 5, 6, 7, 8, 9, 0. **IMPORTANT:** Digits 1, 2, 3, and 4 cannot be used when changing access codes for any mailbox (including primary).

1. Press a mailbox button for mailbox 1, 2, 3, 4. For primary mailbox, follow steps 2 to 6.
2. Press and hold down the **CODE** button until you hear the announcement "Please enter the code number."
3. Press and hold down the **DAY** button. Release the button when you hear the desired first digit of the code.
4. Press and hold down the **HOUR** button. Release the button when you hear the desired second digit of the code.
5. Press and hold down the **MINUTE** button. Release the button when you hear the desired third digit of the code.
6. Press the **CODE** button, the 3-digits you have selected will be announced.



Using the Remote Voice Instruction Code

1. Dial your telephone number.
2. Listen to or bypass the OGM in primary mailbox.
3. Enter your Remote Access Code. If the announcement does not stop, enter the code again.
4. The system will request that you enter the instruction code or press "0" for help.
 - A. If you do not know the instruction code, press "0" immediately. The system will announce the Group I instruction codes. Otherwise, if a command is not received by the system within 10 seconds, it will signal 3 beeps and hang up.

Group I Instruction Codes

Press "2" to play messages.

While playing messages, press "1" to repeat or "3" to skip.

While playing messages, press "4" to stop.

Press "6" to leave a memo. (To leave a memo on individual mailbox, press "1" for mailbox 1, press "2" for mailbox 2, press "3" for mailbox 3, and press "4" for mailbox 4.)

Press "6" again to stop taking message.

Press "7" to play OGM, press "77" to change OGM, press "7" again to stop.

- B. After the last instruction code of Group I, the system will request that you enter the instruction code number or press "0" for help.
- C. Press "0" to access to Group II Instruction Voice Menu.

Group II Instruction Codes

Press "8" to answer OFF, press "8" again to answer ON.

While playing messages, press "9" to erase message.

Press "99" to erase all messages.

Press "*" to change mailbox.

- D. Press the corresponding number of the instruction code you wish to activate. You don't have to listen to the entire instruction voice help menu before giving a command. You may enter the desired instruction code number at any given time.

NOTE: Pressing "0" while the instruction voice help menu is being announced will prompt the system to repeat Group I instruction voice help menu.

Security System



Your cordless telephone uses a digital coding security system to prevent unauthorized use of your telephone line by another nearby cordless telephone. The system has its own identifying signal created by microcomputers in both the BASE UNIT and HANDSET.

Security Code

This telephone has an internal security code with 65,536 possible combinations. Each time you pick up the HANDSET, the code is randomly set to a new combination.

Resetting Security Code and Channel Information

Communication between HANDSET and BASE UNIT may not be possible in any of the following situations:

1. After a power failure.
2. After relocating the BASE UNIT by disconnecting the AC ADAPTOR.
3. After replacing the HANDSET battery.

To reset, place the HANDSET on the BASE UNIT for 2 to 5 seconds.

Multi-Channel Access

Your cordless telephone lets you select a channel from the 40 frequencies available to transmit signals between the BASE UNIT and HANDSET. When you notice interference from other cordless telephones, change to another channel by pressing the **SCAN** button on the HANDSET.



Battery Type

Use the following type and size battery pack:
Cordless Telephone Battery Pack
3.6V, 600mAh
U.S. Electronics Inc.
Ni-Cd Battery Pack: model B650



This battery pack is available through:
U.S. Electronics Service Center
105 Madison Avenue
New York, NY 10016
1-800-338-1694

Recharging the Battery Pack

The nickel cadmium (Ni-Cd) batteries in the HANDSET can be recharged many times using the built-in charger in the BASE UNIT.

When the battery is low, a "beep" sound will be heard every 12 seconds. This indicates that the battery pack needs to be recharged.

Charge the batteries at least once every 90 days of non-use to avoid battery failure. When the battery pack can no longer be charged, replacement of the battery pack will be necessary.

The battery used in your telephone may develop a condition known as "MEMORY". Once subjected to a regular short discharging routine, the battery assumes the discharging pattern it was subjected to. This is known as a "MEMORY" condition which causes rapid discharging shortening the battery charge span. If you believe your battery has developed a memory condition, do not charge the HANDSET until the battery low warning starts beeping. When it does come on, charge the HANDSET fully for 12 hours.

IMPORTANT

In order to get maximum life from the HANDSET battery pack, be sure to charge the HANDSET for 12 hours before initial use.

Changing the Battery

Changing the Battery Pack

The battery pack provides power for the HANDSET of your cordless telephone.

To Replace the Battery Pack:

1. Remove the HANDSET battery compartment cover by sliding it down.
2. Pull out the battery connector and remove the battery pack.
3. Plug the new battery pack into the battery connector.
4. Slide the HANDSET battery compartment cover firmly into place in its closed position.
5. Before use, charge the new battery pack for 12 hours.

ATTENTION:

The product that you have purchased contains a rechargeable battery. The battery is recyclable. At the end of its useful life, under various state and local laws, it may be illegal to dispose of this battery into the municipal waste stream. Check with your local solid waste officials for details in your area for recycling options or proper disposal.

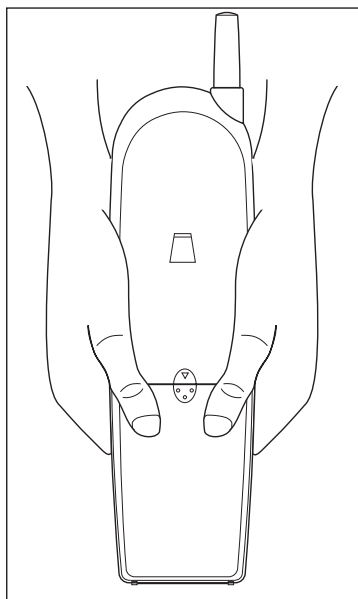

Remove the HANDSET battery compartment cover by sliding it down.

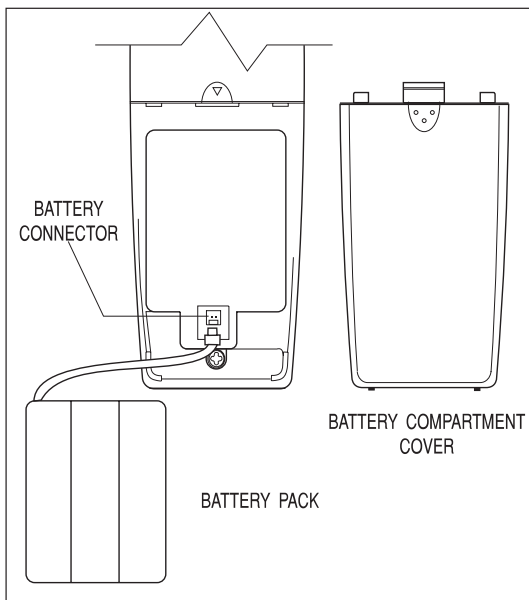



Problem Solving Section

For your assistance, we have listed below a few common problems.

Phone does not work, check the following:

1. BASE UNIT is plugged into power source.
2. HANDSET is charged.
3. TONE/PULSE SWITCH is in the right position.
4. LINE CORD is plugged in the jack.

Range of phone limited, check the following:

1. ANTENNA on the BASE UNIT is raised.
2. BASE UNIT is centrally located in your residence.
3. BASE UNIT is not located near appliances.

No dial tone, check the following:

1. Telephone plug is connected to the telephone line.
2. If you had a power failure or had unplugged the BASE UNIT, replace the HANDSET on the BASE UNIT for 2 to 5 seconds to reset the system.

Received signal flutters or fades, check the following:

1. Battery pack in the HANDSET is fully charged.
2. HANDSET is not too far from the BASE UNIT.
3. ANTENNA on the BASE UNIT is raised.

Interference on reception, check the following:

1. Noise may be picked up from electrical products in the home or electrical storms. Generally, this noise is a minor annoyance and should not be interpreted as a defect in your system. (See Technical Information on page 38.)
2. Choose an alternate channel using the **SCAN** button on the HANDSET.

Excess static, check the following:

1. Check to see that the ANTENNA is not touching another metal object.
Raise the ANTENNA.

If after pressing the TALK button, you receive three beeps and no dial tone, check the following:

1. Reset the HANDSET by placing it on the BASE UNIT for 2 to 5 seconds.

Problem Solving

Answering System does not work, check the following:

1. BASE UNIT is plugged into power source.
2. Reset the system by pressing the **RESET** button at the side of BASE UNIT.

Answering System does not answer calls, check the following:

1. Answer ON/OFF Indicator is lit.

Answers calls only after 10 rings, check the following:

1. Answer ON/OFF Indicator is lit.
2. Message memory is not full.

Battery low indicator lit up, check the following:

1. 4 AAA size Batteries are properly installed.
2. Batteries need to be replaced.

Does not respond to remote commands, ensure the following:

1. Correct Remote Access Code is entered.
2. A Tone telephone is being used.

Messages are incomplete, ensure the following:

1. MESSAGE memory is not full.
2. Caller may be hesitating and pausing for more than 7 seconds.

Answers calls but does not record messages, check the following:

1. ANNC/ICM switch is set to ICM.
2. Memory is not full.
3. Extension telephone was not picked up.

NOTE: If no telephones in the house are working, disconnect one set at a time to verify that none of the telephones are causing the problem. If you still have a problem after doing this and your telephone still does not work, please contact your local phone company.

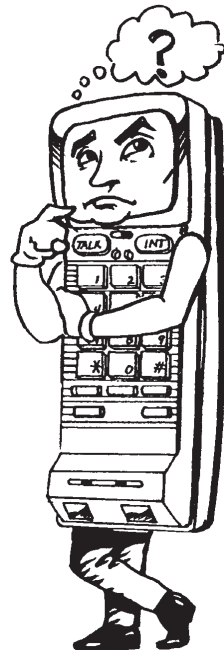

IMPORTANT

When you hear interference,
press the **SCAN** button to change
the operating channel.



Technical Information

This cordless telephone uses radio frequencies to allow mobility. There are certain difficulties in using radio frequencies with a cordless telephone. While these are normal, the following could affect operation of your system.

Noise

Electrical pulse noise is present in most homes at one time or another. This noise is most intense during electrical storms. Certain kinds of electrical equipment such as light dimmers, fluorescent bulbs, motors, and fans also generate noise pulses. Because radio frequencies are susceptible to these noise pulses, you may occasionally hear them in your HANDSET. Generally they are a minor annoyance and should not be interpreted as a defect in your system.

Range

Because radio frequency is used, location of the BASE UNIT can affect operating range. Try several locations in your home or business and pick the one that gives you the clearest signal to the HANDSET.

Interference

Electronic circuits activate a relay to connect the cordless telephone to your telephone line. These electronic circuits operate in the radio frequency spectrum. While several protection circuits are used to prevent unwanted signals, there may be periods when these unwanted signals enter the BASE UNIT. You may hear clicks or hear the relay activate while you are not using the HANDSET. If interference occurs frequently, it can be minimized or eliminated by lowering the height of your base antenna or by relocating the BASE UNIT. You can check for interference before selecting the final BASE UNIT location by plugging in the phone.

NOTICE:

This cordless telephone uses radio communication between the HANDSET and the BASE UNIT and may not ensure privacy of communication. Other devices, including other cordless telephones, may interfere with the operation of this cordless telephone or cause noise during operation. Units not containing coded access may be accessed by other radio communication systems. Cordless telephones must not cause interference to any licensed radio service.

Federal Communications Commission Requirements

This equipment complies with Part 68 of FCC Rules. A label on the BASE UNIT of this equipment contains, among other information, the FCC Registration Number and the Ringer Equivalence Number (REN) for this equipment. You must, upon request, provide this information to your telephone company.

The REN is also useful in determining the quantity of devices that you may connect to your telephone line and still allow these devices to ring when your telephone number is called. In most areas, but not all, the sum of the RENs for all devices connected to one line should not exceed five (5.0). To be certain of the number of devices that you may connect to your line, you should contact your local telephone company.

If your equipment should cause harm to the telephone network, the telephone company may temporarily disconnect your service. If possible, they will notify you in advance that temporary discontinuance of service may be required. However, when advance written notice is not possible, the telephone company may temporarily discontinue service without notice if such action is necessary under the circumstances. The telephone company may make changes in its communication facilities, equipment, operations, or procedures where such action is reasonably required in the operation of its business and is not inconsistent with the rules and regulations of the Federal Communications Commission. **Do not attempt to repair or modify this equipment.**

Warning: Changes or modifications not expressly approved by the party responsible for its compliance could void the user's authority to operate the equipment.

Some cordless telephones operate at frequencies that may cause interference to nearby TVs and VCRs. To minimize or prevent such interference, the base of the cordless telephone should not be placed on or near a TV or VCR. If interference is experienced, moving the cordless telephone farther away from the TV or VCR will often reduce or eliminate the interference.

This equipment should not be used on coin telephone lines. Connection to party line service is subject to state tariffs. If trouble is experienced, disconnect this equipment from the telephone line to determine if it is causing the malfunction. If the equipment is determined to be malfunctioning, its use should be discontinued until the problem has been corrected.

IMPORTANT

In order to get maximum life from the HANDSET battery pack, be sure to charge the HANDSET for 12 hours before initial use.

Federal Communications Commission Requirements (continued)

Note: This equipment has been tested and found to comply with the limits for a class B digital device, pursuant to Part 15 of the FCC Rules. These limits are designed to provide reasonable protection against harmful interference in a residential installation. This equipment generates, uses and can radiate radio frequency energy and, if not installed and used in accordance with the instructions, may cause harmful interference to radio communications.

However, there is no guarantee that interference will not occur in a particular installation. If this equipment does cause harmful interference to radio or television reception, which can be determined by turning the equipment off and on, the user is encouraged to try to correct the interference by one or more of the following measures.

1. Re-orient or relocate the receiving antenna.
2. Increase the distance between the equipment and receiver.
3. Connect the equipment into an outlet on a circuit different from that to which the receiver is connected.
4. Consult the dealer or an experienced radio / TV technician for help.

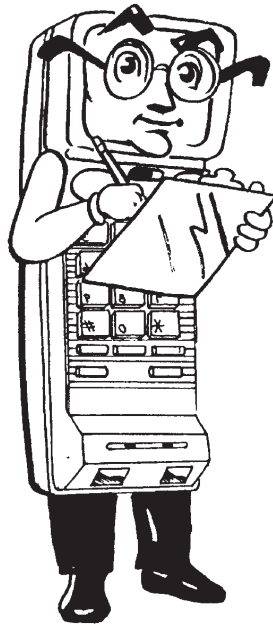

Warranty Information

BellSouth Products

One-Year Limited Warranty

This limited warranty sets forth all **BellSouth Products** responsibilities regarding your product. There are no other expressed or implied warranties from **BellSouth Products**.

Warranty Service Provided

If you purchased the telephone new from a retail vendor, **BellSouth Products** warrants the telephone against defects in material and workmanship for a period of one (1) year from the original date of purchase. This warranty is in lieu of all other expressed warranties. This warranty begins when you purchase the telephone and continues for one (1) year unless you sell or rent the telephone, in which case the warranty stops.

BellSouth Products disclaims any implied warranty, including the warranty of merchantability and the warranty of fitness for a particular purpose, as of the date of one year from your original purchase of the telephone.

BellSouth Products assumes no responsibility for any special, incidental, or consequential damages.

This warranty gives you specific legal rights and you may have other rights which vary from state to state. Some states do not allow the exclusion or limitations of special, incidental or consequential damages, or limitations on how long a warranty lasts, so the above exclusion and limitation may not apply to you.

Warranty Service Not Provided

This warranty does not cover damage resulting from accident, misuse, abuse, improper installation or operation, lack of reasonable care, unauthorized modification, the affixing of any attachment not provided by **BellSouth Products** with the telephone and/or loss of parts. This warranty is voided in the event any unauthorized person opens, alters or repairs the telephone. All **BellSouth** equipment being returned for repair must be suitably packaged. Telephone companies use different types of equipment and offer various types of services to customers. **BellSouth Products** does not warrant that this telephone is compatible with the type of equipment of any particular telephone company or the services provided by it.



What To Do for Warranty Service

During the first thirty (30) days, a defective product is eligible for over-the-counter exchange at the retailer from whom it was purchased. After thirty (30) days, the defective product should be returned to the authorized service center. Please allow 2-3 weeks for the return of your telephone product unless other instructions are provided by U. S. Electronics. The shipping address of the authorized service center is:

U.S. Electronics Service Center
105 Madison Avenue
New York, NY 10016

NOTE: A product received which was not made for **BellSouth Products** or which is not defective as determined by our test procedures will not be repaired and will be returned C.O.D., freight.

To Obtain Warranty Service

- Provide proof of the date of purchase within the package.
- Prepay all shipping costs to the authorized service center.
- Include a return shipping address within the package.

Please retain your sales receipt, the carton, the packing materials, and the printed material. The original carton is the best shipping container for the telephone should you have to return it.

For your reference:

Serial Number _____

Date of Purchase _____

Name of Dealer _____

***Customer Service Telephone Number:
1-800-210-8950***

OUTSIDE THE U.S.A. CALL 1-212-242-6978

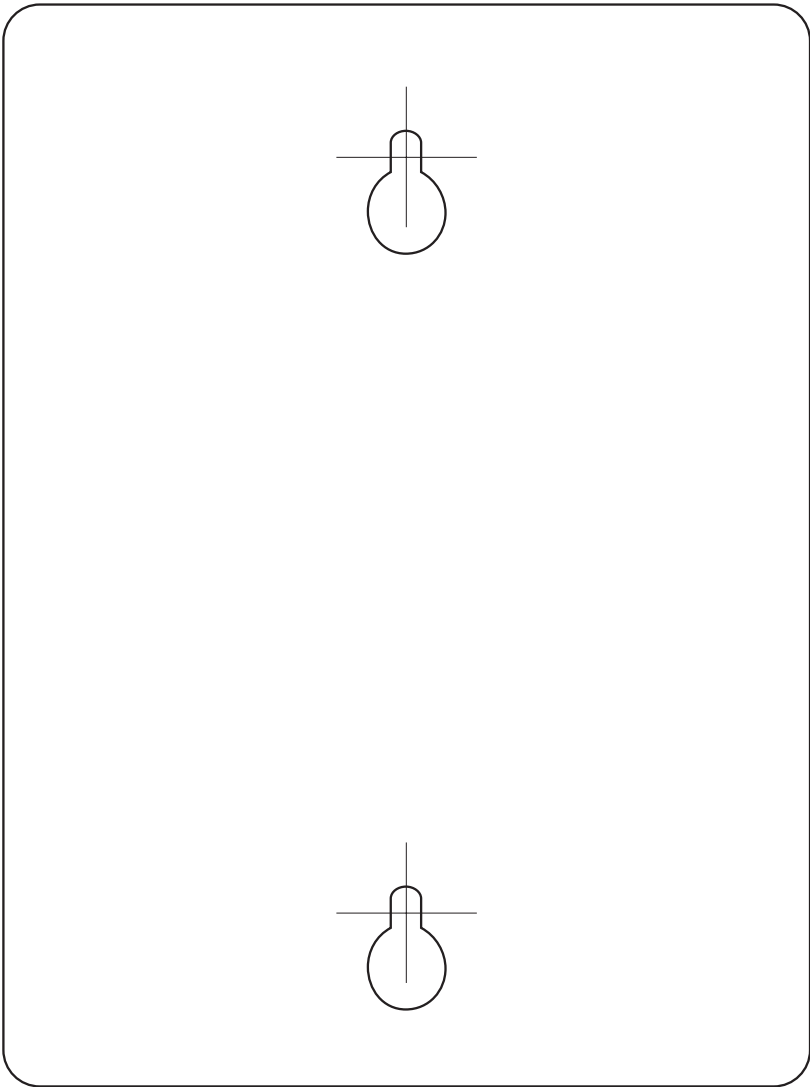

This page serves as a template for attachment of screws to the wall when mounting this telephone on the wall.

1. Cut out this page.
2. Use this template to determine the distance between screws when mounting this phone on the wall.
The two cross hairs identify where to attach the screws.

CORDLESS ALL DIGITAL ANSWERING SYSTEM

900MHz FILTERED SOUND™ 40 CHANNEL AUTOSCAN
WITH 4 INDIVIDUAL MAILBOXES

Model MH9043

OWNER'S MANUAL
INSTALLATION AND
OPERATING
INSTRUCTIONS

***PLEASE READ THIS
MANUAL CAREFULLY
BEFORE USE.
KEEP FOR YOUR
REFERENCE.***

***For Getting Started Information,
please see Installation Instructions
on page 15 or your separate
Quick Start guide.***

