



# Contents

Safety Instructions .....	3
HANDSET Controls - Location and Function .....	5
BASE UNIT Controls - Location and Function .....	7
Getting Started .....	9
Desk Mounting .....	12
Wall Mounting .....	13
Cordless Telephone Operation .....	14
Preparing for Use .....	14
Receiving Calls .....	15
Placing Calls .....	16
HANDSET Redial Feature .....	16
Extension Telephones .....	16
Caller ID System Operation .....	17
Caller ID System .....	17
Viewing Caller Information During Incoming Calls .....	17
Message Waiting .....	17
Call Waiting .....	18
Caller List .....	18
Viewing the Caller List .....	18
Placing a Call from the Caller List .....	19
Editing the Caller List before Dialing .....	19
Saving the Name and Number in the Caller List into the Directory .....	19
Deleting All Records in the Caller List .....	20
Selective Deleting in the Caller List .....	20
Name and Telephone Number Directory .....	20
Viewing the Directory .....	20
Speed Viewing the Directory .....	20
Saving in the Directory .....	21



Preferred Calls .....	21
Blocked Calls .....	21
Editing Name and Number in the Directory .....	22
Editing the Number in the Directory before Dialing .....	23
Placing Calls from the Directory .....	24
Deleting All Records in the Directory .....	24
Selective Deleting in the Directory .....	24
Function Operation .....	25
A. Language .....	26
B. Silent On/Off .....	26
C. Time Set .....	26
D. Ringer Volume .....	27
E. Contrast .....	27
F. PBX Number .....	27
G. PBX Mode .....	28
H. Pause Time .....	28
I. MSG Waiting (Message Waiting) .....	28
Telephone Keypad Characters .....	29
Security .....	30
Recharging the Battery Pack .....	31
Changing the Battery Pack .....	32
Problem Solving .....	33
Technical Information .....	35
FCC Requirements .....	36
Warranty Information .....	38
Wall Mount Template .....	43

# Safety Instructions

## **IMPORTANT SAFETY INSTRUCTIONS**

***To reduce the risk of fire, electric shock and/or injury, always follow these basic safety precautions when using your cordless telephone equipment.***

1. Read and understand all instructions.
2. Follow all warnings and instructions marked on the telephone.
3. Unplug this telephone from the wall outlet before cleaning or replacing batteries. Do not use liquid cleaners or aerosol cleaners. Use a damp cloth for cleaning. If necessary, use only a mild soap.
4. Do not use this telephone near a bathtub, kitchen sink, wash bowl, laundry tub, swimming pool, in a wet basement, or anywhere else where there is water.
5. Do not place this telephone on an unstable cart, stand or table. A fall could cause serious damage to the phone.
6. This product should never be placed near or over a radiator or heat register. This product should not be placed in a built-in installation unless proper ventilation is provided.
7. Operate this telephone only with the correct electrical voltage shown on the label or in the Owner's Manual. If you are not sure of the voltage in your home, consult your dealer or local power company.
8. Do not allow anything to rest on the power cord. Do not install the phone where people will walk on the cord.
9. Do not overload wall outlets and extension cords. This can increase the risk of fire or electric shock.
10. Never push objects of any kind through slots in the phone. They could touch dangerous voltage points or short out parts that could result in a risk of fire or electric shock. Never spill liquid of any kind on the telephone.
11. To reduce the risk of electric shock, do not take this telephone apart. When service or repair work is required on this telephone, take it to a qualified service representative. Opening or removing covers may expose you to dangerous voltage or other risks. Incorrect re-assembly can cause electric shock when the appliance is used.
12. Unplug this telephone from the wall outlet and consult a qualified service representative in any of the following situations:
  - A. When the power supply cord is frayed or damaged.
  - B. If liquid has been spilled into the telephone.
  - C. If the product has been exposed to rain or water.
  - D. If the telephone does not operate normally by following the operating instructions. Adjust only those controls that are covered by the operating instructions. Improper adjustment of other controls may result in damage and will often require extensive work by a qualified technician to restore the telephone to normal operation.
  - E. If the telephone has been dropped or the case has been damaged.

# Safety Instructions

- F. If the telephone exhibits a distinct change in performance.
- 13. Avoid using a telephone (other than a cordless type) during an electrical storm. There may be a remote risk of electric shock from lightning.
- 14. Do not use the telephone to report a gas leak in the vicinity of the leak.
- 15. Never install telephone wiring during a lightning storm.
- 16. Never install telephone jacks in wet locations unless the jack is specifically designed for wet locations.
- 17. Never touch uninsulated telephone wires or terminals unless the telephone line has been disconnected at the network interface.
- 18. Use caution when installing or modifying telephone lines.

## Battery Safety

### CAUTION:

**To reduce the risk of fire or personal injury, read and follow these instructions:**

1. Use only the following type and size battery pack:  
Cordless Telephone Battery Pack  
3.6V, 600mAh  
U.S. Electronics Inc.  
Ni-Cd Battery Pack: model B650  
(See page 35 for ordering information.)
2. Do not dispose of the battery pack in a fire. It may explode. Check with local codes for possible special disposal instructions.
3. Do not open or mutilate the battery pack. Released electrolyte is corrosive and may cause damage to the eyes or skin. It may be toxic if swallowed.
4. Exercise care in handling the battery pack to prevent shorting the battery with conductive materials such as rings, bracelets and keys. The battery or conductor may overheat and cause burns.
5. Charge the battery pack provided with or identified for use with this product only in accordance with the instructions and limitations specified in this manual.



### ATTENTION:

The product that you have purchased contains a rechargeable battery. The battery is recyclable. At the end of its useful life, under various state and local laws, it may be illegal to dispose of this battery into the municipal waste stream. Check with your local solid waste officials for details in your area for recycling options or proper disposal.

**SAVE THESE INSTRUCTIONS.**

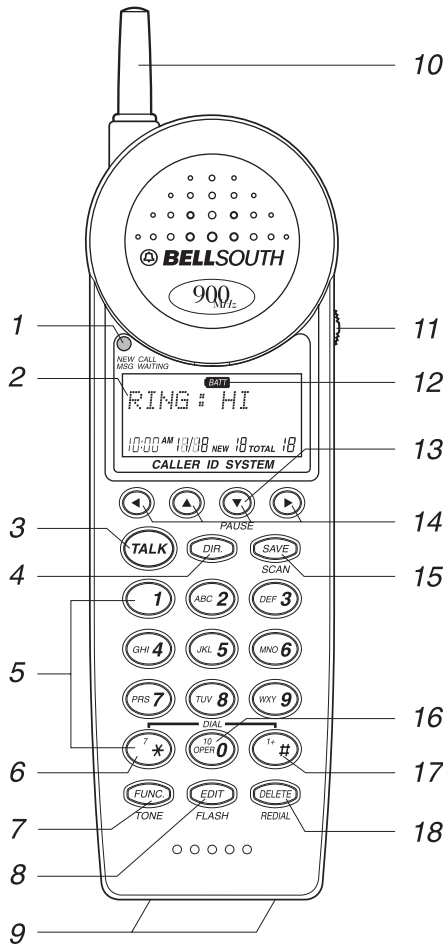

## HANDSET Controls

- 1. New Call/MSG (Message) Waiting LED Indicator:** Blinks in green when recording new incoming call. Blinks in red when receiving Message Waiting signal, if you have subscribed from your local telephone company. (See page 17 for details.)
- 2. Large LCD Screen:** Shows call information, phone status prompts and directory items.
- 3. Talk Button:** Press to answer an incoming call or to place a call. Press to end a call. Press twice to stop paging.



4. **DIR. (Directory) Button:** Press to access names and numbers stored in the DIRECTORY. (See page 20 to 24 for details.)
5. **Telephone Keypad:** Allows you to make a call depending on pressed button. (For letters see page 29.)
6. **7 Digit Button:** Press to place a local call.
7. **Func. (Function)/Tone Button:** Press to access special functions operation in STANDBY mode. (For special functions see page 25.) Press to change the dialing mode temporarily from Pulse to Tone for Rotary Service Users. (Press once before entering numbers to access the answering system or electronic banking services, etc.)
8. **Edit/Flash Button:** Press to edit listed items. Press to answer a call if you have Call Waiting.
9. **Charge Contacts:** For charging battery inside the HANDSET. We recommend cleaning the charge contacts periodically with a damp cloth.
10. **ANTENNA**
11. **Volume Control (HI, LOW) Switch :** Select the volume level (HI, LOW).
12. **Batt Low Indicator:** Lights up when the battery power is low. (See page 31 for details.)
13. **Pause Button:** Press to insert a pause while dialing. (You will need the **PAUSE** button to dial numbers which use an alternative long distance access code.)
14. **Navigation Buttons (▲ ▼ ◀ ▶):** Press to move around the Large LCD Screen.
15. **Save/Scan Button:** Press to save changes on the listed items. Press to change the operating channel when you hear interference.
16. **10 Digit Button:** Press to place a local call with Area Code.
17. **1+ Digit Button:** Press to place a long distance call. (Automatically adds the number 1 at the beginning of the displayed telephone number.)
18. **Delete/Redial Button:** Press to delete items or individual characters. Press to redial the last number called.

## IMPORTANT

In order to get maximum life from the HANDSET battery pack, be sure to charge the HANDSET for 12 hours before initial use.

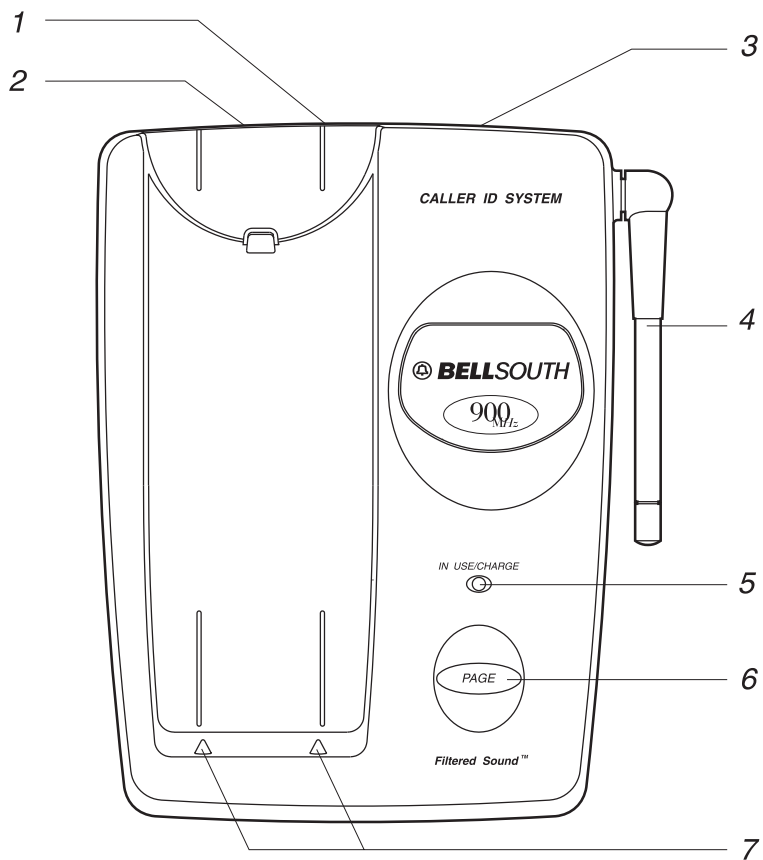

1. **Tone/Pulse Select Switch**
2. **Telephone Line Connection Jack**
3. **Power-In Connection Jack**
4. **ANTENNA:** Raise for the best reception.
5. **In Use/Charge Indicator:** Lights up when the unit is ON or when the HANDSET is placed on the BASE UNIT for charging. It flashes to indicate an incoming call.
6. **Page Button:** Press to page the HANDSET, press again to stop.
7. **Charge Contacts:** We strongly recommend cleaning of the charge contacts periodically with a damp cloth.

## IMPORTANT

Placing your BASE UNIT near appliances such as televisions, refrigerators, radios, or microwave ovens may cause interference.



## Connecting Your Phone

This section is a [reference guide](#) to the basic functions and operations of your cordless telephone. For more detailed descriptions of the operations and features of this telephone, refer to the Contents on page 1.

1. Carefully remove your cordless telephone from its shipping carton. If there is any visible damage, do not attempt to operate this equipment. Return it to the place of purchase.
2. Check to be sure you have all items that come with this cordless telephone system. You should have a HANDSET, BASE UNIT, AC ADAPTOR, MOUNTING BRACKET, TELEPHONE LINE CORD, SHORT TELEPHONE LINE CORD and Owner's Manual.



HANDSET

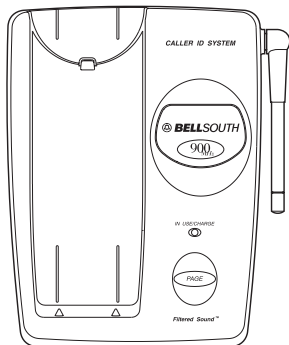

BASE UNIT

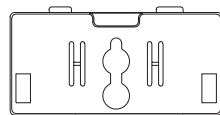

MOUNTING BRACKET

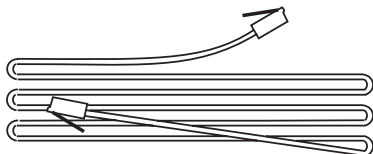

TELEPHONE LINE CORD



AC ADAPTOR



SHORT TELEPHONE LINE CORD

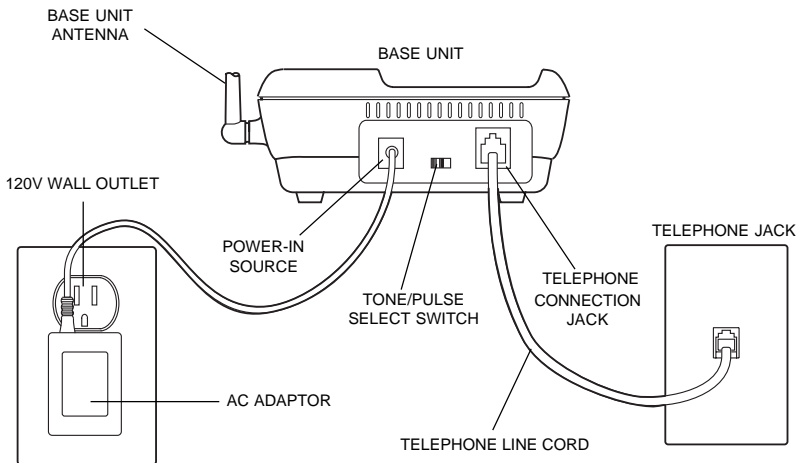

3. Insert the small plug on the end of the AC ADAPTOR into the POWER-IN connection jack on the back of the BASE UNIT.
4. Plug the AC ADAPTOR into a 120V AC wall outlet.
5. Insert one plug of the TELEPHONE LINE CORD into the house TELEPHONE JACK and the other into the telephone line jack on the back of the BASE UNIT. (If you have an older 4-prong telephone jack, you will need an RJ-11C TELEPHONE JACK ADAPTOR. This adaptor is available at the same place you purchased your telephone.)
6. Set the date and time. (See page 26 for details.)
7. Raise the ANTENNA on the BASE UNIT for the best reception.
8. We recommend not placing this unit next to appliances. Doing so may cause interference.
9. TONE/PULSE Select Switch:
  - A. If your home is equipped with a tone dialing system, set the TONE/PULSE select switch to the TONE position.
  - B. If you have a rotary dialing system, set TONE/PULSE select switch to the PULSE position.
  - C. If you are unsure which system you have, set the TONE/PULSE select switch to the TONE position. Press the **TALK** button on the HANDSET to get a dial tone, and press any key on the keypad except the zero. If the dial tone continues, you do not have tone dialing service. Press the **TALK** button on the HANDSET to hang up. Set the TONE/PULSE select switch to the PULSE mode and try again.

# Getting Started

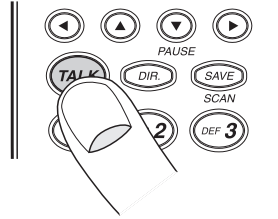
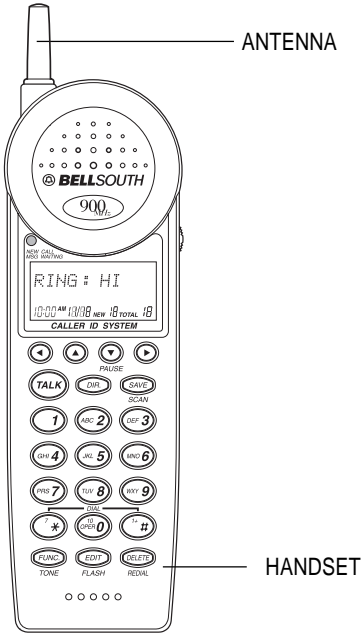

Press the **TALK** button to confirm that you have a dial tone. If you do not get a dial tone, review steps 3 through 9. If you still have no dial tone, refer to the Problem Solving section on page 33.

**10. Before initial use, charge the HANDSET for 12 hours.**

*You are now ready to use your new BellSouth Cordless Telephone.*

## IMPORTANT

In order to utilize the Caller ID feature, you must subscribe to Caller ID service from your local phone company.

## Desk Mounting

One of the special features of your equipment is the unique design of the MOUNTING BRACKET which can hold your phone at an angle of 45° when desk mounting. There are two positions to choose from:

**1. NORMAL POSITION (Mounting Bracket not required)**

For Normal Position, as shown in Figure 1, place the BASE UNIT on any desired but suitable location.

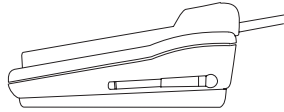

FIGURE 1

**2. 45° POSITION (See Figure 2)**

With the back of the BASE UNIT facing up, insert the bottom hooks of the MOUNTING BRACKET into the matching slots of the BASE UNIT (as specified in Figure 3). Then push the top hooks of the MOUNTING BRACKET into place.

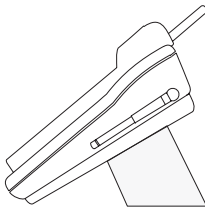

FIGURE 2

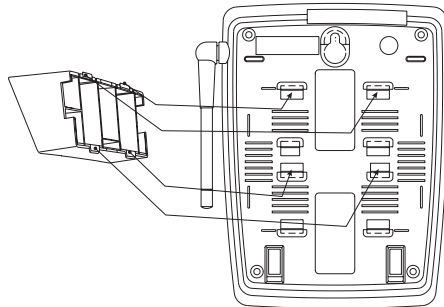
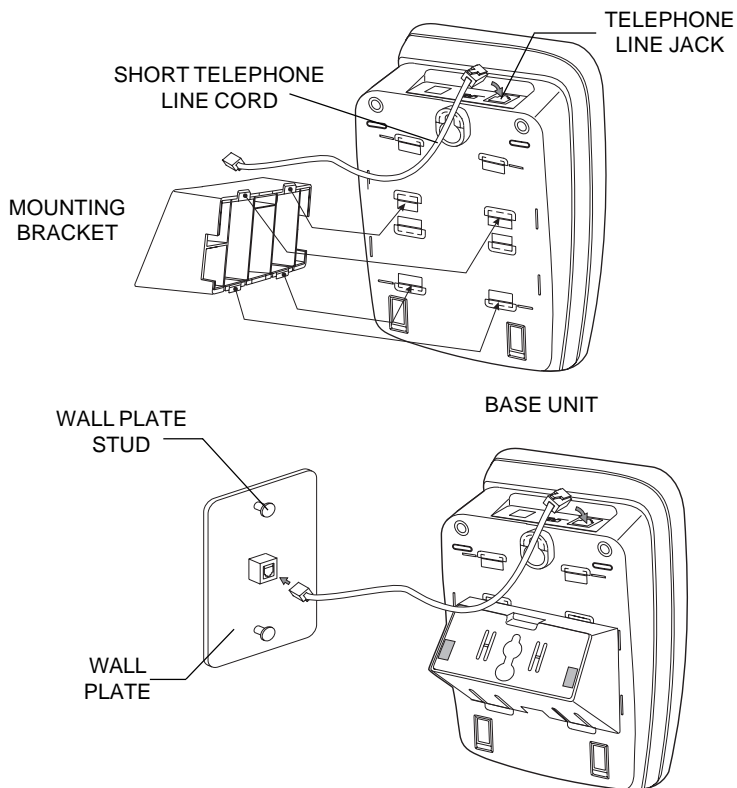

FIGURE 3

## Wall Mounting

You may choose to put the BASE UNIT of your cordless telephone on a wall.

1. With the back of the BASE UNIT facing up, connect the SHORT TELEPHONE LINE CORD to the telephone line jack.
2. Insert the top hooks of the MOUNTING BRACKET into the matching slots of the BASE UNIT (as shown below). Then push the bottom hooks of the MOUNTING BRACKET into place. Plug the free end of the SHORT TELEPHONE LINE CORD into the MODULAR WALL JACK.
3. Align the upper keyhole on the MOUNTING BRACKET with the upper STUD of the wall plate, so that the opening end of the MOUNTING BRACKET matches the lower stud, then pull the BASE UNIT down until securely seated.





## **Preparing for Use**

Before you can use your cordless telephone, you must charge the HANDSET for 12 hours. Failure to do so will require recharging of the battery pack more often.

1. Place the HANDSET on the BASE UNIT for 12 hours.
2. After 12 hours, remove the HANDSET from the BASE UNIT.
3. **RAISE THE BASE UNIT ANTENNA FOR BEST RECEPTION.**

***Before you can use your cordless telephone, you must charge the HANDSET for 12 hours. Failure to do so will require more frequent charging of the battery pack. See page 31 for more information on the battery pack.***

## **NOTE :**

Once the HANDSET is fully charged, it is operable for approximately 6 hours of continuous talk use and approximately 5 days when the HANDSET is left off the BASE UNIT in STANDBY mode, depending on the frequency of use.

### **IMPORTANT**

**The AC ADAPTOR must always be plugged into an electrical outlet.**

# Cordless Telephone Operation

## Receiving Calls

1. When the phone rings, lift the HANDSET and press the **TALK** button. The BASE UNIT IN USE indicator will light up.
2. Start your conversation.
3. To end your conversation, either press the **TALK** button or place the HANDSET on the BASE UNIT. If the HANDSET is placed on the BASE UNIT charge cradle, the automatic STANDBY feature is then activated.



**NOTE:** The Call Timer will start to count once you press the **TALK** button.

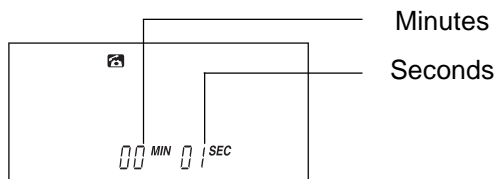

**Call Timer Display**

## IMPORTANT

When you hear interference, press the **SCAN** button to change the operating channel.

## Placing Calls

1. Press the **TALK** button, Call Timer starts to count. The BASE UNIT IN USE indicator will light up.
2. Listen for a dial tone.
3. Dial the phone number.
4. When finished with your call, press the **TALK** button again. The BASE UNIT IN USE indicator will turn off.

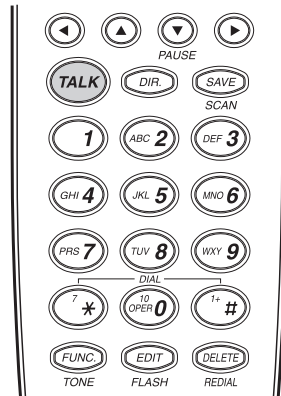

## HANDSET Redial Feature

1. If you get a busy tone, press the **TALK** button to hang up.
2. Press the **TALK** button again.
3. Listen for a dial tone.
4. Press the **REDIAL** button. This will automatically redial the last telephone number you called.
5. When finished with your call, press the **TALK** button again. The BASE UNIT IN USE indicator will turn off.

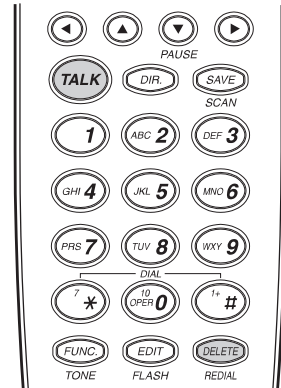

## Extension Telephones

Extension telephones can be connected. When an extension phone is being used, the BASE UNIT IN USE indicator will start to blink and the HANDSET "EXT IN-USE" will be displayed. This means that an extension telephone is in use. You will have to wait until the line is free to make a call.



# Caller ID System Operation

## Caller ID System

This telephone automatically displays incoming caller's name and telephone number together with the date and time of the call. It records up to 80 calls and stores the data in memory.

**IMPORTANT:** You must subscribe to the Caller ID service from your local telephone company to utilize this feature.

## Viewing Caller Information During Incoming Calls

1. When there is an incoming call, the name and the telephone number of the caller will automatically appear after the second ring. Press the ► button to view the name which are more than 11 digits.

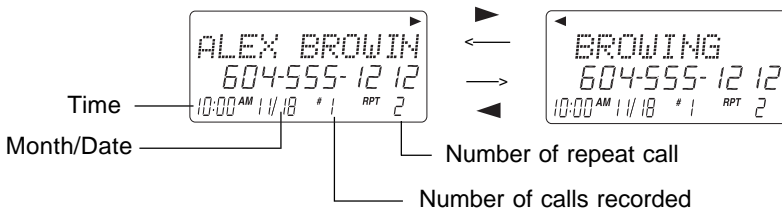

OR

Caller's telephone number will appear if the caller's name is not available.

OR

"OUT OF AREA" will appear if the origin of the incoming call does not support Caller ID system.

e.g.

OR

"UNKNOWN" will appear if the origin of the incoming call has no name and does not support Caller ID system.

e.g. Unknown name  
0 is Out of Area

OR

"PRIVATE NAME" and/or "P-- --- ----" will appear if the caller's name and/or telephone number is blocked.

OR

"EXT IN-USE" will appear when an extension phone is being used.

OR

"DATA ERROR" will appear if wrong data was received from the telephone line.

OR

The name stored in the Directory will appear for an incoming call with matching telephone numbers.

## "MSG" (Message Waiting)

The MSG WAITING LED blink in red when there is a message for you from your telephone company if you have subscribed to Voice Mail message service and if you have requested Visual Message Indication from your local telephone company. "MSG" will appear on the LCD Screen in STANDBY mode.

(To remove the message waiting indicator, see page 28 for details.)

# Caller ID System Operation

## Call Waiting

When you have subscribed to Call Waiting service from your local telephone company, this telephone can indicate the name and number of the second caller while you are having a conversation.

1. When you are having a conversation, this telephone will automatically display the name and number of the second caller.
2. Press the **FLASH** button to answer the second caller. The first caller's name and number will be displayed.
3. When you have finished, press the **FLASH** button to continue your conversation with your first caller.

e.g. 

2nd Caller

e.g. 

1st Caller

## "C-F" (Forwarded Call)

Appears on the upper left hand side, when the incoming call has been assigned to your telephone number.

## "L-D-C" (Long Distance)

Appears on the upper left hand side, when the incoming call is a long distance call and the service is provided by your local telephone company.

## Caller List

Records call information for up to 80 incoming calls such as caller's name and telephone number together with the date and time of the call. After recording a new incoming call, the NEW CALL LED indicator will blink in green and the display will look as shown below:



No. of new calls.  
Maximum calls = 80

## Viewing the Caller List

1. Press the **▼** button to view the latest record, or Press the **▲** button to view the first record, press the **▶** button if the name is more than 11 digits.

e.g.

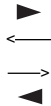

2. Press the **DIR.** button to go back to STANDBY mode.

(If no activate buttons are pressed for 20 seconds or you have viewed the last record in the Caller's List, the LCD Screen will automatically return to STANDBY mode.)

## Placing a Call from the Caller List

1. Press the ▼ button to select from the latest record, or  
Press the ▲ button to select from the first record.
2. Press the **7** button for local call, or  
press the **10** button for local call with area code, or  
press the **1+** button for long distance call.
3. To end your conversation, either press the **TALK** button or  
place the HANDSET on the BASE UNIT.

**NOTE :** You can edit the number before dialing, but you cannot save any changes in the Caller List.

## Editing the Caller List before Dialing

1. Press the ▲ or ▼ button to find the caller.
2. Press the **EDIT** button.
3. Move the cursor by pressing the ◀ or ▶ button to the digit  
you want to change.  
To erase digits, press the **DELETE** button.  
To add digits, use the TELEPHONE KEYPAD (0~9) buttons.
4. Press the **EDIT** button.
5. Press the **7** button for local call, or  
press the **10** button for local call with area code, or  
press the **1+** button for long distance call.
6. To end your conversation, either press the **TALK** button or place  
the HANDSET on the BASE UNIT.

**NOTE :** The name of the caller and time called cannot be edited.

## Saving the Name and Number in the Caller List into the Directory

1. Press the ▲ or ▼ button to find the caller.
2. Press the **SAVE** button.

**NOTE :** It is not advisable to save a telephone number without the corresponding name. This will lead to improper displays of name information.

## Deleting All Records in the Caller List

1. Press and hold down the **DELETE** button at STANDBY mode.
2. The LCD screen will automatically return to STANDBY mode.

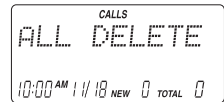

## Selective Deleting in the Caller List

1. Press the **▲** or **▼** button to find the caller at STANDBY mode.
2. Press and hold down the **DELETE** button, then the LCD screen will display the next item in the directory.
3. Press the **DIR.** button to return to STANDBY mode.

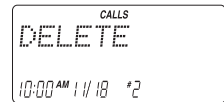

## Name and Telephone Number Directory

This Directory lets you scroll through the list to find the person you need for one touch dialing. You can store up to 40 names and telephone numbers in the memory.

### Viewing the Directory

1. Press the **DIR.** button.

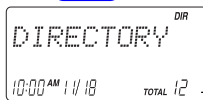

No. of memory stored

2. Press the **▲** or **▼** button to find the one you need, press the **▶** button if the name or telephone number is more than 11 digits.

e.g.



**NOTE:** To exit the Directory List at anytime, press the **DIR.** button.

### Speed Viewing the Directory

1. Press the **DIR.** button.
2. Enter the first letter of a name.  
(See page 29 for details of entering a letter.)
3. Press the **▼** button to find all names with the same first letter.

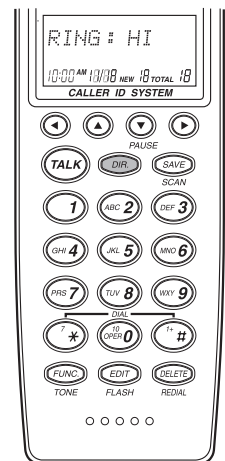

## Saving in the Directory

1. Press the **DIR.** button at STANDBY mode.
2. Press the **EDIT** button.
3. Use the TELEPHONE KEYPAD button (0~9) to enter the name, (see page 29 for details) you can store up to 15 characters.
4. Press the ▼ button once.
5. Enter the telephone number using the TELEPHONE KEYPAD button (0~9). You can store up to 16 digits.
6. Press the **SAVE** button.
7. Press the **DIR.** button to go back to STANDBY mode.

(If no activate buttons are pressed for 20 seconds, the LCD Screen will automatically return to STANDBY mode.)

**NOTE :** It will not save a duplicate telephone number or a name without the corresponding telephone number in the Directory.

## Preferred Calls

You can assign Preferred Call which will generate a special ringer sound at the start of the second ring to any welcome caller in the DIRECTORY.

When you are saving the name and number into the DIRECTORY, add "#" mark at the beginning of the name by pressing the **#** button.

## Blocked Calls

You can assign a Blocked Call which will disable the ringer sound from the second ring, to any caller in the DIRECTORY.

When you are saving the name and number into the DIRECTORY, add " \* " mark at the beginning of the name by pressing the **\*** button.



## Editing Name and Number in the Directory

1. Press the **DIR.** button.
2. Press the **▲** or **▼** button to find the one you want to edit.

e.g.



3. Press the **EDIT** button to edit the name.

e.g.



■ cursor is blinking

4. Press the **◀** or **▶** button to move the cursor to the letter or number you want to change.

To erase, press the **DELETE** button.

To add, use the TELEPHONE KEYPAD buttons (0~9).  
(see page 29 for details.)

5. Press the **▲** or **▼** button to edit the number.

6. Press the **◀** or **▶** button to move the cursor to the number you want to change.

To erase, press the **DELETE** button.

To add, use the TELEPHONE KEYPAD buttons (0~9).  
(See page 29 for details.)

e.g.

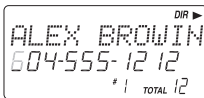

— cursor is blinking

7. Press the **SAVE** button to confirm.

**IMPORTANT:** It is not advisable to save a telephone number without the corresponding name. This will lead to improper displays of name information.

**NOTE:** When no activate buttons are pressed for 20 seconds, the LCD Screen will automatically return to STANDBY mode.

## Editing the Number in the Directory before Dialing

1. Press the **DIR.** button.
2. Press the **▲** and **▼** button to find the caller.
3. Press the **EDIT** button.
4. Press the **▼** button.  
e.g.



— cursor is blinking

5. Press the **◀** or **▶** button to move the cursor to the number you want to change.  
To erase, press the **DELETE** button.  
To add, use the TELEPHONE KEYPAD buttons.
6. Press the **EDIT** button.
7. Press the **7** button for local call, or  
press the **10** button for local call with area code, or  
press the **1+** button for long distance call.
8. To end your conversation, either press the **TALK** button or place the HANDSET on the BASE UNIT.

**NOTE:** If you want to save the edited number in the Directory, follow steps 1 through 5 and then press the **SAVE** button.



## Placing Calls from the Directory

1. Press the **DIR.** button.
2. Press the **▲** or **▼** button to find the one you want to call.
3. Press the **7** button for local call, or  
press the **10** button for local call with area code, or  
press the **1+** button for long distance call.
4. To end your conversation, either press the **TALK** button or place the HANDSET on the BASE UNIT.

## Deleting All Records in the Directory

1. Press the **DIR.** button.
2. Press and hold down the **DELETE** button at STANDBY mode.

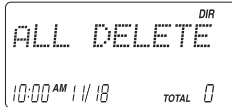

3. Press the **DIR.** button to return to STANDBY mode.

## Selective Deleting in the Directory

1. Press the **DIR.** button.
2. Press the **▲** or **▼** button to find the one you want to delete.
3. Press and hold down the **DELETE** button, then the LCD screen will display the next item in the directory.

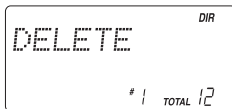

4. Press the **DIR.** button to return to STANDBY mode.



# Caller ID System Operation

## Function Operation

This unit contains the following special functions:

- A. LANGUAGE
- B. SILENT ON/OFF
- C. TIME SET
- D. RINGER VOLUME
- E. CONTRAST
- F. PBX NUMBER
- G. PBX ON/OFF
- H. PAUSE TIME
- I. MSG WAITING

To access, press the **FUNC.** button at STANDBY mode, then press the TELEPHONE KEYPAD (1~9) or the ▲ or ▼ buttons.

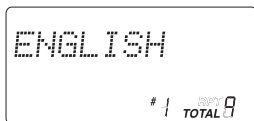

KEYPAD Button # 1

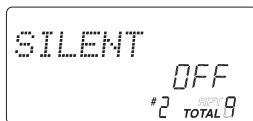

KEYPAD Button # 2



KEYPAD Button # 3

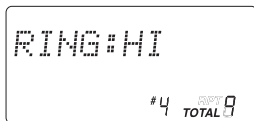

KEYPAD Button # 4

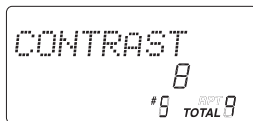

KEYPAD Button # 5

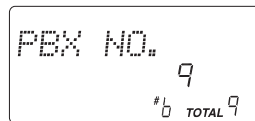

KEYPAD Button # 6

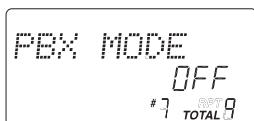

KEYPAD Button # 7

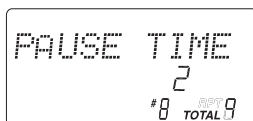

KEYPAD Button # 8

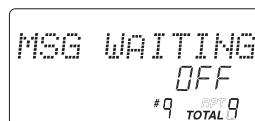

KEYPAD Button # 9

## IMPORTANT

In order to utilize the Caller ID feature,  
you must subscribe to Caller ID service from  
your local telephone company.



## A. Language

This telephone offers English, Spanish and French languages for your convenience.

1. Press the **FUNC.** button.
2. Press the TELEPHONE KEYPAD #1 button.
3. Press the **EDIT** button.
4. Press the ▲ or ▼ button to select the type of language you desire. English is the preset language.
5. Press the **SAVE** button.
6. Press the **FUNC.** button to go back to STANDBY mode.

## B. Silent On/Off

This telephone will generate the first ring sound even in the Blocked Call mode to indicate that you have an incoming call. To keep silent in BLOCKED CALL mode you can turn off the first ring sound.

1. Press the **FUNC.** button.
2. Press the TELEPHONE KEYPAD #2 button.
3. Press the **EDIT** button.
4. Press the ▲ or ▼ button. Silent Off is the preset mode.
5. Press the **SAVE** button.
6. Press the **FUNC.** button to go back to STANDBY mode.

## C. Time Set

Set the date and time.

1. Press the **FUNC.** button.
2. Press the TELEPHONE KEYPAD #3 button.
3. Press the **EDIT** button.
4. Use the TELEPHONE KEYPAD button to enter the month, date, hour and minute. The cursor moves automatically after entering each item.  
Press the TELEPHONE KEYPAD #1 for AM setting, or press the TELEPHONE KEYPAD #2 for PM setting.
5. Press the **FUNC.** button to go back to STANDBY mode.

**NOTE:** The date and time will automatically set, if you have subscribed to the Caller ID service from your local telephone company.

## D. Ringer Volume

This unit enables you to adjust the ringer volume from HI, LOW and OFF as desired.

1. Press the **FUNC.** button.
2. Press the TELEPHONE KEYPAD #4 button.
3. Press the **EDIT** button.
4. Press the ▲ or ▼ button to adjust the ringer volume suitable for your convenience. (HI is the preset ringer volume.)
5. Press the **SAVE** button.
6. Press the **FUNC.** button to go back to STANDBY mode.

## E. Contrast

This unit enables you to select 8 brightness levels for the Large LCD display.

1. Press the **FUNC.** button.
2. Press the TELEPHONE KEYPAD #5 button.
3. Press the **EDIT** button.
4. Press the ▲ or ▼ button to adjust the brightness of the display. Level 4 is the preset brightness.
5. Press the **SAVE** button.
6. Press the **FUNC.** button to go back to STANDBY mode.

## F. PBX Number

This unit enables you to preset the PBX number (such as an 8 or 9) while you are using a switchboard system.

1. Press the **FUNC.** button.
2. Press the TELEPHONE KEYPAD #6 button.
3. Press the **EDIT** button.
4. Press the ▲ or ▼ button. (9 is the preset PBX number.)
5. Press the **SAVE** button.
6. Press the **FUNC.** button to go back to STANDBY mode.



## G. PBX Mode

This unit enables you to turn ON/OFF the PBX system depending on the telephone system you are using.

1. Press the **FUNC.** button.
2. Press the TELEPHONE KEYPAD #7 button.
3. Press the **EDIT** button.
4. Press the ▲ or ▼ button.  
PBX MODE OFF - Set for direct line access. The preset PBX mode is OFF.  
PBX MODE ON - When connected to a switchboard system.
5. Press the **SAVE** button.
6. Press the **FUNC.** button to go back to STANDBY mode.

**NOTE:** When placing a call in PBX mode ON, this telephone will automatically add the PBX number and a pause time before the dialed telephone numbers.

## H. Pause Time

This unit enables you to adjust the pause time for dialing on switchboard system or long distance calls.

1. Press the **FUNC.** button.
2. Press the TELEPHONE KEYPAD #8 button.
3. Press the **EDIT** button.
4. Press the ▲ or ▼ button to adjust the pausing time.  
2 seconds is the preset pause time.
5. Press the **SAVE** button.
6. Press the **FUNC.** button to go back to STANDBY mode.

## I. MSG Waiting (Message Waiting)

To turn off the Message Waiting LCD indicator.

1. Press the **FUNC.** button.
2. Press the TELEPHONE KEYPAD #9 button.
3. Press the **EDIT** button.
4. Press the ▲ or ▼ button.
5. Press the **SAVE** button.
6. Press the **FUNC.** button to go back to STANDBY mode.

**IMPORTANT:** Message Waiting LCD indicator will automatically turn on, if you have subscribed to Voice Mail message service and if you have Visual Message Indication from your local telephone company.

## Telephone Keypad Characters

The Telephone Keypad buttons (1–9) are used to enter the characters when entering names. Press the appropriate keypad button to get the following characters.

KEYPAD BUTTONS	CHARACTERS
1	SPACE & ' ( ) * . 1
2	A B C 2
3	D E F 3
4	G H I 4
5	J K L 5
6	M N O 6
7	P Q R S 7
8	T U V 8
9	W X Y Z 9
*	*
0	0
#	#

For example, if you want to enter the character "S", press the "7" key, the first character displayed will be "P". Press the "7" key again to display "Q", and twice more to display the letter "S".

To enter the next character, press the appropriate key. If, however, the next character is on the same key as the previous character, you will first need to press the ► key. Pressing the ► a second time will produce a space. If you want to change any character, you can go back to the incorrect character by pressing ◀ button. To delete the character inside the cursor "■", press the **DELETE** button.

## Security System



Your cordless telephone uses a digital coding security system to prevent unauthorized use of your telephone line by another nearby cordless telephone. The system has its own identifying signal created by microcomputers in both the BASE UNIT and HANDSET.

### **Security Code**

This telephone has an internal security code with 65,536 possible combinations. Each time you pick up the HANDSET, the code is randomly set to a new combination.

### **Resetting Security Code and Channel Information**

Communication between HANDSET and BASE UNIT may not be possible in any of the following situations:

1. After a power failure.
2. After relocating the BASE UNIT by disconnecting the AC ADAPTOR.
3. After replacing the HANDSET battery.

To reset, place the HANDSET on the BASE UNIT for 2 to 5 seconds.

### **Multi-Channel Access**

Your cordless telephone lets you select a channel from the 40 frequencies available to transmit signals between the BASE UNIT and HANDSET. When you notice interference from other cordless telephones, change to another channel by pressing the **SCAN** button on the HANDSET.

# Recharging the Battery Pack

## Battery Type

Use the following type and size battery pack:

Cordless Telephone Battery Pack

3.6V, 600mAh

U.S. Electronics Inc.

Ni-Cd Battery Pack: model B650



Ni-Cd

This battery pack is available through:

U.S. Electronics Service Center

105 Madison Avenue

New York, NY 10016

1-800-338-1694

## Recharging the Battery Pack

The nickel cadmium (Ni-Cd) batteries in the HANDSET can be recharged many times using the built-in charger in the BASE UNIT.

When the battery is low, a "beep" sound will be heard every 12 seconds. This indicates that the battery pack needs to be recharged.

Charge the batteries at least once every 90 days of non-use to avoid battery failure. When the battery pack can no longer be charged, replacement of the battery pack will be necessary.

The battery used in your telephone may develop a condition known as "MEMORY". Once subjected to a regular short discharging routine, the battery assumes the discharging pattern it was subjected to. This is known as a "MEMORY" condition which causes rapid discharging shortening the battery charge span. If you believe your battery has developed a memory condition, do not charge the HANDSET until the battery low warning starts beeping. When it does come on, charge the HANDSET fully for 12 hours.

### IMPORTANT

In order to get maximum life from the HANDSET battery pack, be sure to charge the HANDSET for 12 hours before initial use.

# Changing the Battery Pack

## Changing the Battery Pack

The battery pack provides power for the HANDSET of your cordless telephone.

### To Replace the Battery Pack:

1. Remove the HANDSET battery compartment cover by sliding it down.
2. Pull out the battery connector and remove the battery pack.
3. Plug the new battery pack into the battery connector.
4. Slide the HANDSET battery compartment cover firmly into place in its closed position.
5. Before use, charge the new battery pack for 12 hours.

### ATTENTION:

The product that you have purchased contains a rechargeable battery. The battery is recyclable. At the end of its useful life, under various state and local laws, it may be illegal to dispose of this battery into the municipal waste stream. Check with your local solid waste officials for details in your area for recycling options or proper disposal.

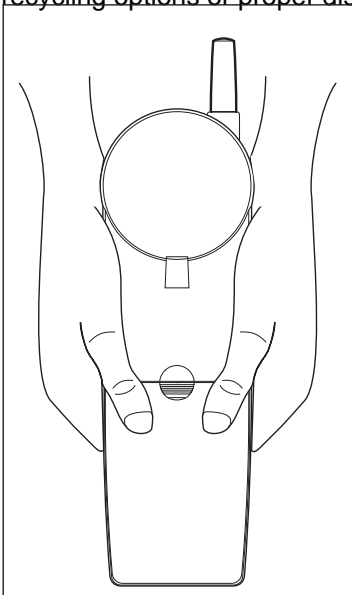

Remove the HANDSET battery compartment cover by sliding it down.

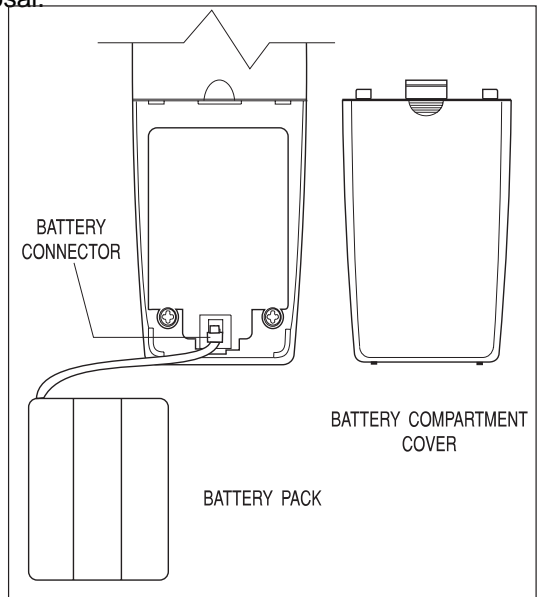



## Problem Solving Section

For your assistance, we have listed below a few common problems.

### *Phone does not work, check the following:*

1. BASE UNIT is plugged into power source.
2. HANDSET is charged.
3. TONE/PULSE SWITCH is in the right position.
4. LINE CORD is plugged in the jack.

### *Range of phone limited, check the following:*

1. ANTENNA on BASE UNIT is raised.
2. BASE UNIT is centrally located in your residence.
3. BASE UNIT is not located near appliances.

### *No dial tone, check the following:*

1. Telephone plug is connected to the telephone line.
2. If you had a power failure or had unplugged the BASE UNIT, replace the HANDSET on the BASE UNIT for 2 to 5 seconds to reset the system.

### *Received signal flutters or fades, check the following:*

1. Battery pack in HANDSET is fully charged.
2. HANDSET is not too far from the BASE UNIT.
3. ANTENNA on BASE UNIT is raised.

### *Interference on reception, check the following:*

1. Noise may be picked up from electrical products in the home or electrical storms. Generally, this noise is a minor annoyance and should not be interpreted as a defect in your system. (See Technical Information on page 35.)
2. Choose an alternate channel using the **SCAN** button on the HANDSET.

### *Long Distance "L-D-C" indicator is not ON when receiving long distance call, check the following:*

1. Your local telephone company can provide the Area Code on an incoming long distance call.

# Problem Solving

## *Excess static, check the following:*

1. Check to see that the ANTENNA is not touching another metal object.  
Raise the ANTENNA.

## *If after pressing the TALK button, you receive three beeps and no dial tone, check the following:*

1. Reset the HANDSET by placing it on the BASE UNIT for 2 to 5 seconds.

**NOTE:** If no telephones in the house are working, disconnect one set at a time to verify that none of the phones are causing the problem. If you still have a problem after doing this and your telephone still does not work, please contact your local phone company.

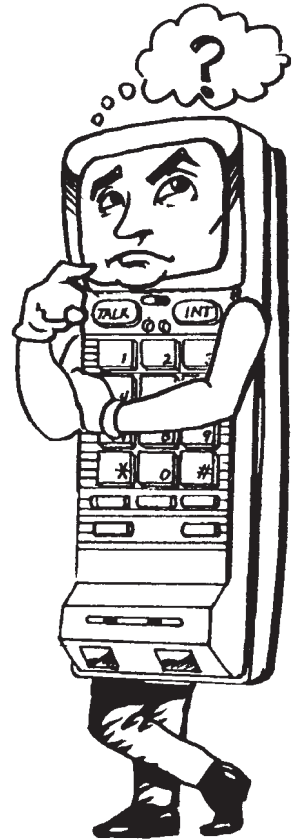

## **IMPORTANT**

When you hear interference,  
press the SCAN button to change  
the operating channel.

### **Technical Information**

This cordless telephone uses radio frequencies to allow mobility. There are certain difficulties in using radio frequencies with a cordless telephone. While these are normal, the following could affect operation of your system.

#### **Noise**

Electrical pulse noise is present in most homes at one time or another. This noise is most intense during electrical storms. Certain kinds of electrical equipment such as light dimmers, fluorescent bulbs, motors, and fans also generate noise pulses. Because radio frequencies are susceptible to these noise pulses, you may occasionally hear them in your HANDSET. Generally they are a minor annoyance and should not be interpreted as a defect in your system.

#### **Range**

Because radio frequency is used, location of the BASE UNIT can affect operating range. Try several locations in your home or business and pick the one that gives you the clearest signal to the HANDSET.

#### **Interference**

Electronic circuits activate a relay to connect the cordless telephone to your telephone line. These electronic circuits operate in the radio frequency spectrum. While several protection circuits are used to prevent unwanted signals, there may be periods when these unwanted signals enter the BASE UNIT. You may hear clicks or hear the relay activate while you are not using the HANDSET. If interference occurs frequently, it can be minimized or eliminated by lowering the height of your base antenna or by relocating the BASE UNIT. You can check for interference before selecting the final BASE UNIT location by plugging in the phone.

#### **NOTICE:**

This cordless telephone uses radio communication between the HANDSET and the BASE UNIT and may not ensure privacy of communication. Other devices, including other cordless telephones, may interfere with the operation of this cordless telephone or cause noise during operation. Units not containing coded access may be accessed by other radio communication systems. Cordless telephones must not cause interference to any licensed radio service.



## Federal Communications Commission Requirements

This equipment complies with Part 68 of FCC Rules. A label on the BASE UNIT of this equipment contains, among other information, the FCC Registration Number and the Ringer Equivalence Number (REN) for this equipment. You must, upon request, provide this information to your telephone company.

The REN is also useful in determining the quantity of devices that you may connect to your telephone line and still allow these devices to ring when your telephone number is called. In most areas, but not all, the sum of the RENs for all devices connected to one line should not exceed five (5.0). To be certain of the number of devices that you may connect to your line, you should contact your local telephone company.

If your equipment should cause harm to the telephone network, the telephone company may temporarily disconnect your service. If possible, they will notify you in advance that temporary discontinuance of service may be required. However, when advance written notice is not possible, the telephone company may temporarily discontinue service without notice if such action is necessary under the circumstances. The telephone company may make changes in its communication facilities, equipment, operations, or procedures where such action is reasonably required in the operation of its business and is not inconsistent with the rules and regulations of the Federal Communications Commission. **Do not attempt to repair or modify this equipment.**

**Warning:** Changes or modifications not expressly approved by the party responsible for its compliance could void the user's authority to operate the equipment.

Some cordless telephones operate at frequencies that may cause interference to nearby TVs and VCRs. To minimize or prevent such interference, the base of the cordless telephone should not be placed on or near a TV or VCR. If interference is experienced, moving the cordless telephone farther away from the TV or VCR will often reduce or eliminate the interference.

This equipment should not be used on coin telephone lines. Connection to party line service is subject to state tariffs. If trouble is experienced, disconnect this equipment from the telephone line to determine if it is causing the malfunction. If the equipment is determined to be malfunctioning, its use should be discontinued until the problem has been corrected.

### IMPORTANT

In order to get maximum life from the HANDSET battery pack, be sure to charge the HANDSET for 12 hours before initial use.

## *Federal Communications Commission Requirements (continued)*

**Note:** This equipment has been tested and found to comply with the limits for a class B digital device, pursuant to Part 15 of the FCC Rules. These limits are designed to provide reasonable protection against harmful interference in a residential installation. This equipment generates, uses and can radiate radio frequency energy and, if not installed and used in accordance with the instructions, may cause harmful interference to radio communications.

However, there is no guarantee that interference will not occur in a particular installation. If this equipment does cause harmful interference to radio or television reception, which can be determined by turning the equipment off and on, the user is encouraged to try to correct the interference by one or more of the following measures.

1. Re-orient or relocate the receiving antenna.
2. Increase the distance between the equipment and receiver.
3. Connect the equipment into an outlet on a circuit different from that to which the receiver is connected.
4. Consult the dealer or an experienced radio / TV technician for help.

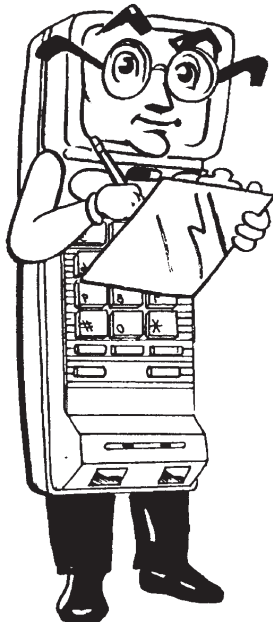

## Warranty Information

### BellSouth Products

#### One-Year Limited Warranty

This limited warranty sets forth all **BellSouth Products** responsibilities regarding your product. There are no other expressed or implied warranties from **BellSouth Products**.

### Warranty Service Provided

If you purchased the telephone new from a retail vendor, **BellSouth Products** warrants the telephone against defects in material and workmanship for a period of one (1) year from the original date of purchase. This warranty is in lieu of all other expressed warranties. This warranty begins when you purchase the telephone and continues for one (1) year unless you sell or rent the telephone, in which case the warranty stops.

**BellSouth Products** disclaims any implied warranty, including the warranty of merchantability and the warranty of fitness for a particular purpose, as of the date of one year from your original purchase of the telephone.

**BellSouth Products** assumes no responsibility for any special, incidental, or consequential damages.

This warranty gives you specific legal rights and you may have other rights which vary from state to state. Some states do not allow the exclusion or limitations of special, incidental or consequential damages, or limitations on how long a warranty lasts, so the above exclusion and limitation may not apply to you.

### Warranty Service Not Provided

This warranty does not cover damage resulting from accident, misuse, abuse, improper installation or operation, lack of reasonable care, unauthorized modification, the affixing of any attachment not provided by **BellSouth Products** with the telephone and/or loss of parts. This warranty is voided in the event any unauthorized person opens, alters or repairs the telephone. All **BellSouth** equipment being returned for repair must be suitably packaged. Telephone companies use different types of equipment and offer various types of services to customers. **BellSouth Products** does not warrant that this telephone is compatible with the type of equipment of any particular telephone company or the services provided by it.

## **What To Do for Warranty Service**

During the first thirty (30) days, a defective product is eligible for over-the-counter exchange at the retailer from whom it was purchased. After thirty (30) days, the defective product should be returned to the authorized service center. Please allow a minimum of 3 weeks for the return of your product unless other instructions are provided by U. S. Electronics. The shipping address of the authorized service center is:

U.S. Electronics Service Center  
105 Madison Avenue  
New York, NY 10016

**NOTE:** A product received which was not made for **BellSouth Products** or which is not defective as determined by our test procedures will not be repaired and will be returned C.O.D., freight.

## **To Obtain Warranty Service**

- . Provide proof of the date of purchase within the package.
- . Prepay all shipping costs to the authorized service center.
- . Include a return shipping address within the package.

Please retain your sales receipt, the carton, the packing materials, and the printed material. The original carton is the best shipping container for the telephone should you have to return it.

For your reference:

Serial Number \_\_\_\_\_

Date of Purchase \_\_\_\_\_

Name of Dealer \_\_\_\_\_

**Customer Service Telephone Number:  
1-800-210-8950**

**OUTSIDE THE U.S.A. CALL 1-212-242-6978**





## Wall Mount Template

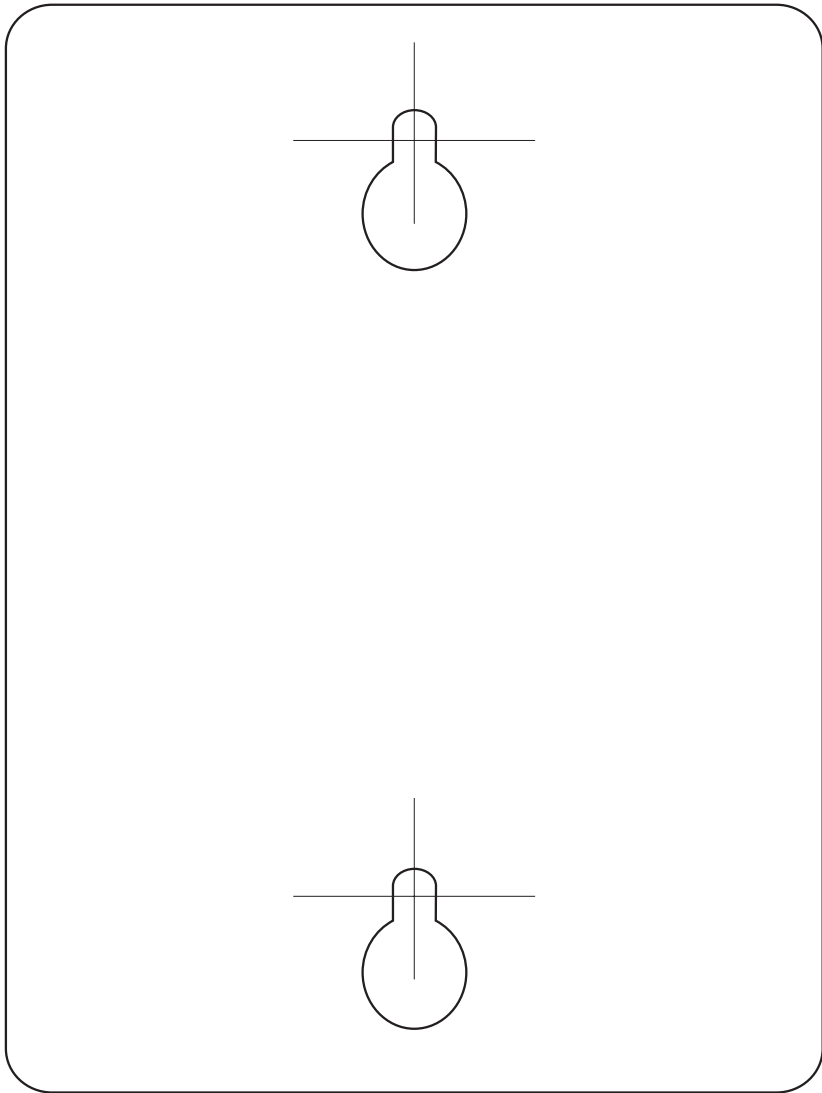

This page serves as a template for attachment of screws to the wall when mounting this telephone on the wall.

1. Cut out this page.
2. Use this template to determine the distance between screws when mounting this phone on the wall.  
The two cross hairs identify where to attach the screws.

# CORDLESS CALLER ID TELEPHONE WITH CALL WAITING

900MHz FILTERED SOUND™ WITH 40 CHANNEL AUTOSCAN

## Model MH9910

OWNER'S MANUAL  
INSTALLATION AND  
OPERATING  
INSTRUCTIONS

***PLEASE READ THIS  
MANUAL CAREFULLY  
BEFORE USE.  
KEEP FOR YOUR  
REFERENCE.***

***For Getting Started Information,  
please see Installation Instructions  
on page 9 or your separate  
Quick Start guide.***

