

## MODEL NUMBER ALLOCATION

Presently, we have a large number of models within each of our various model number series of cordless telephones.

Our clients continually request slightly different cosmetic variations of each registered model such as a different case color .

In order to control all of these permutations, it is constantly necessary to assign and file, with the FCC, new model numbers to cover these cosmetic variations.

**Since all models, within a series of cordless telephones, are electrically and functionally identical, varying only in cosmetic detail** and to avoid the need to constantly file, with the FCC, to register additional model numbers for cosmetic purposes, we request to register our models as listed tradenames and model numbers:

TRADENAMES		MODEL NUMBERS
BELLSOUTH	}	D(HAC) MH9003(0)(Y)      D(HAC) MH9014(0)(Y)
AMERITECH		D(HAC) MH9004(0)(Y)      D(HAC) MH9015(0)(Y)
BELL ATLANTIC		D(HAC) MH9101(0)(Y)      D(HAC) MH9016(0)(Y)
PACIFIC BELL		D(HAC) MH9011(0)(Y)      D(HAC) MH9017(0)(Y)
UNISONIC		D(HAC) MH9012(0)(Y)      D(HAC) MH9018(0)(Y)
		D(HAC) MH9013(0)(Y)      D(HAC) MH9019(0)(Y)

NOTE: (0) Zero = Additional charger base  
 suffix "Y" can be added to the model number to represent color variation, can be any letter/s of the alphabet as follows  
 (but not limited to this list) such as :

"No suffix"	=	Gray case
B/BK	=	Black case
HG/VHG	=	Green case
W	=	White case
R	=	Red case
RB	=	Red/Black case
PL	=	Pearl white case

such that :

MH9003	-	Model MH9003 is the standard model in gray case
MH9003B	-	Model MH9003 in black case
MH9003HG	-	Model MH9003 in green case

# FREQUENCY OF 1602 P.L.L

- \* CHANNEL SPACE : 25KHz
- \* 1st I.F. : 10.7 MHz
- \* 2nd I.F. : 450KHz
- \* TCXO(X-TAL) : 11.15MHz

CH	BASE(MHz)		PORTABLE(MHz)	
	TX	LOCAL(10.7)	TX	LOCAL(10.7)
1	902.125	936.825	926.125	891.425
2	902.150	936.850	926.150	891.450
3	902.175	936.875	926.175	891.475
4	902.200	936.900	926.200	891.500
5	902.225	936.925	926.225	891.525
6	902.250	936.950	926.250	891.550
7	902.275	936.975	926.275	891.575
8	902.300	937.000	926.300	891.600
9	902.325	937.025	926.325	891.625
10	902.350	937.050	926.350	891.650
11	902.375	937.075	926.375	891.675
12	902.400	937.100	926.400	891.700
13	902.425	937.125	926.425	891.725
14	902.450	937.150	926.450	891.750
15	902.475	937.175	926.475	891.775
16	902.500	937.200	926.500	891.800
17	902.525	937.225	926.525	891.825
18	902.550	937.250	926.550	891.850
19	902.575	937.275	926.575	891.875
20	902.600	937.300	926.600	891.900
21	902.625	937.325	926.625	891.925
22	902.650	937.350	926.650	891.950
23	902.675	937.375	926.675	891.975
24	902.700	937.400	926.700	892.000
25	902.725	937.425	926.725	892.025
26	902.750	937.450	926.750	892.050
27	902.775	937.475	926.775	892.075
28	902.800	937.500	926.800	892.100
29	902.825	937.525	926.825	892.125
30	902.850	937.550	926.850	892.150
31	902.875	937.575	926.875	892.175
32	902.900	937.600	926.900	892.200
33	902.925	937.625	926.925	892.225
34	902.950	937.650	926.950	892.250
35	902.975	937.675	926.975	892.275
36	903.000	937.700	927.000	892.300
37	903.025	937.725	927.025	892.325
38	903.050	937.750	927.050	892.350
39	903.075	937.775	927.075	892.375
40	903.100	937.800	927.100	892.400

# MH-9003 (V4) CIRCUIT DESCRIPTION

## **A. BASE UNIT**

1. TEL-LINE INTERFACE
2. RING DETECT
3. POWER SUPPLY
4. AUDIO AMPLIFIER AND COMPANDOR
5. DTMF GENERATOR
6. 20dB/30dB CONTROL
7. DATA COMMUNICATION INTERFACE
8. INTERCOM FUNCTION
9. BASE RF MODULE

## **B. PORTABLE UNIT**

1. LOW BATTERY DETECTION CIRCUIT
2. BUZZER
3. INDICATOR CATEGORY
4. AUDIO AMPLIFIER AND COMPANDOR
5. PORTABLE RF MODULE

## A. BASE SET

### 1. TEL-LINE INTERFACE

TEL-LINE INTERFACE CIRCUIT CONSISTS OF A RELAY, DIODE BRIDGE (D1~D4), TRANSFORMER (T1), AND SPEECH NETWORK CIRCUIT AS FOLLOWS FIG.1  
A DC LOOP IS CONFIGURED WHEN CPU PIN 41 ARE SET HIGH  
THE LOOP CURRENT FLOWS AS FOLLOWS :  
TIP1(1)->FUSE1->R35->T1->D2, D1/D3, D4->RING1(1)  
THE PULSE SIGNAL FROM CPU PIN 41 ARE TRANSMITTED THROUGH LS1 TO TURN ON AND OFF THE TEL LINE.

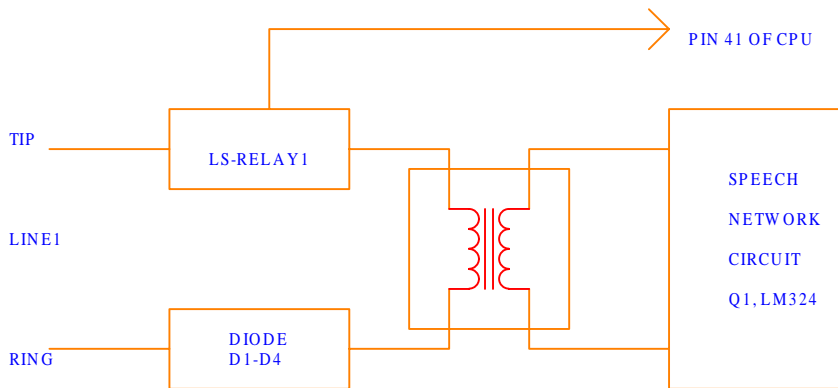

FIG.1

## 2. RING DETECT

THE RING SIGNAL SUPPLIED BETWEEN T AND R PASSES THROUGH THE FOLLOWING PROCEDURES AND IS DETECTED BY THE CPU.

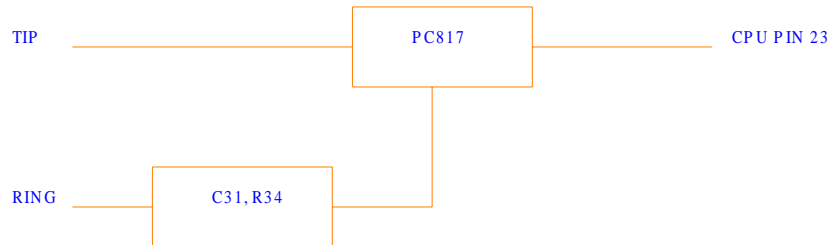

FIG.2

## 3. POWER SUPPLY

3-1 THE OUTPUT VOLTAGE OF IC6 IS REGULATED 5V AND THIS VOLTAGE IS USED BY MAIN SUPPLYING VOLTAGE OF CPU AND TX,RX POWER.

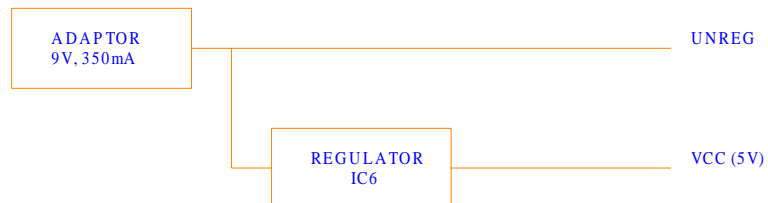

FIG.3

#### 4. AUDIO AMPLIFIER AND COMPANDOR

##### 4-1 TX PART:

THE TRANSMITTED SIGNALS FROM TELEPHONE LINE ARE FEED TO COMPANDOR IC(IC2) THROUGH THE AUDIO AMPLIFIER AND THE RECEIVED SIGNALS FROM TELEPHONE LINE ARE ALSO FEED TO AUDIO AMPLIFIER THROUGH THE SPEECH NETWORK NETWORK CIRCUIT.

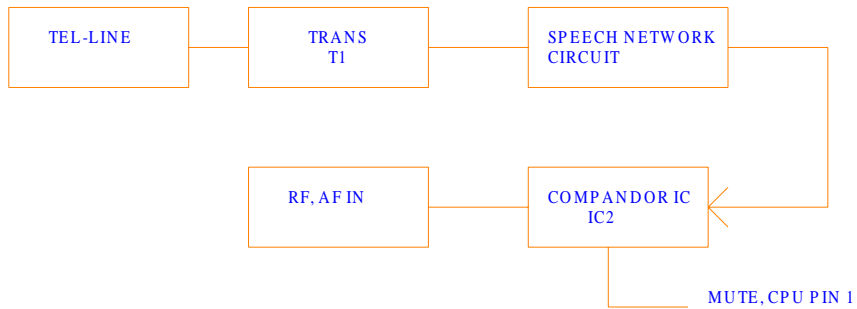

FIG.4

##### 4-2 RX PART:

THE RECEIVED SIGNALS FROM AF OUT OF RF MODULE, FEED TO COMPANDOR FOR NOISE ELIMINATION. THIS SIGNAL THROUGH MATCHING TRANS T1, ALSO FEED TO TELEPHONE LINE THROUGH THE SPEECH NETWORK CIRCUIT TO TRANSFER TO OTHER PARTY.

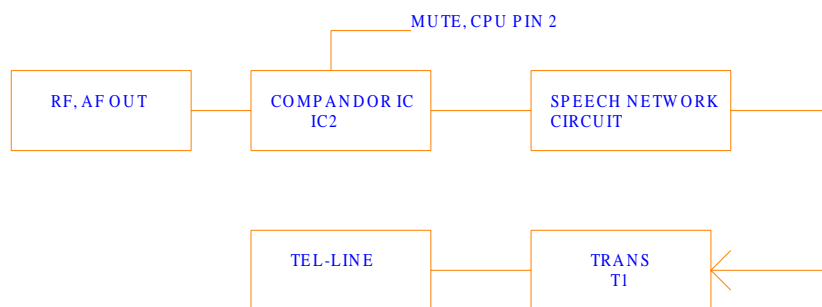

FIG.5

## 5. DTMF GENARATOR

THE CPU DTMF GENARATOR IS INTENDED TO PROVIDE DUAL-TONE MULTI-FREQUENCY (DTMF) FOR TONE DIALLING SYSTEM. THE DTMF SIGNAL THROUGH SPEECH NETWORK CIRCUIT OUTPUT TEL-LINE. DTMF CONTROL PIN 6,7,8,9,10,11 OF CPU



FIG.6

## 6. 20dB CONTROL

RSSI LEVEL (20 dB) OUTPUT FROM THE IF CIRCUIT THROUGH IC5D OPAMP OUT OF IS DETECTING BY PIN 42 OF CPU.



FIG.7

## 7. DATA COMMUNICATION INTERFACE.

\* DATA COMMUNICATION IS OPERATED SERIAL OUTPUT

7-1 PIN 26 (SI) OF CPU :

DATA SIGNAL WILL RECEIVE FROM THE PORTABLE UNIT AS THROUGH FILTER CIRCUIT IC5A, IC5B AND DATA SIGNAL INPUT PIN 26 (SI) OF CPU



7-2 PIN 27 (SO) OF CPU :

DATA SIGNAL WILL SEND TO THE PORTABLE UNIT AS THROUGH PIN 27 (SO) OF CPU



FIG.8

## 8. PAGING FUNCTION

PAGING FUNCTION CAN BE SELECTED EITHER FROM BASE TO PORTABLE UNIT. THE INTERCOM FUNCTION CAN BE ENABLED BY PRESSING THE PAGING KEY IN THE BASE SET.

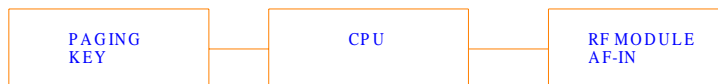

FIG.9



## 9. BASE RF MODULE

### 9-1. RX PART

THE RECEIVER FRONT-END CONTAINS A BAND PASS FILTER, AN RF LOW NOISE AMPLIFIER, A BAND PASS FILTER, A ACTIVE TRANSISTOR MIXER, A MONOLITHIC CRYSTAL FILTER AND 10.7MHz IF AMPLIFIER.

ALSO IT INCLUDES

BUFFER AMPLIFIERS FOR THE GENERATION OF LOCAL OSCILATOR POWER.

THIS FRONT-END RECEIVER RECEIVES AN RF SIGNAL FROM THE ANTENNA. AND RF SIGNALS WITHIN THIS FREQUENCY RANGE IS 926.125MHz-927.100MHz PASS THROUGH RF AMP (Q303,Q306) AND BAND PASS FILTER.

AFTER PASSING THROUGH THE BAND PASS FILTER, THE SIGNAL IS MIXED WITHIN 1<sup>ST</sup> LOCAL FREQUENCY FROM VOLTAGE CONTROLLED OSCILLATOR.

THE SIGNAL IS AMPLIFIED ON THE IF AMP TRANSISTOR (Q305) AND THE SIGNAL PASS THROUGH THE MONOLITHIC CRYSTAL FILTER (10.7MHz). AFTER THE IF SIGNAL PASS THE MCF FILTER, THE SIGNAL ENTER BY THE FM IF (INTERMEDIATE FREQUENCY) IC.

AND THE SIGNAL IS MIXED IN THE FM IF IC (DBL5018).

THE SIGNAL PASS THROUGH THE CERAMIC FILTER (450KHz).

THE OUTPUT SIGNAL IN THE FM IF IC STREAMS FROM THE AF-OUT TEMINAL OF THE CONNECTOR TO THE BASE.

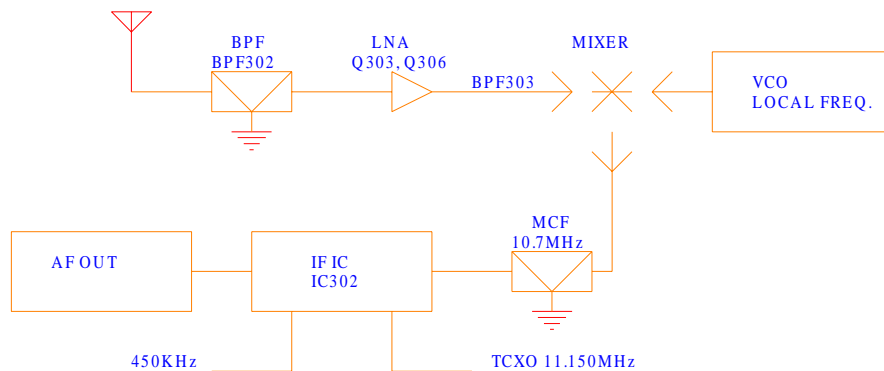

FIG. 10

## 9-2. TX PART

THE SIGNAL IS MADE TO THE PORTABLE, ENTER BY THE AF-IN  
TERMINAL OF THE CONNECTOR.  
THE SIGNAL SEND THE MOD TERMINAL OF THE TX VCO.  
THE SIGNAL IS MIXED IN THE TX VCO  
MIXING THE RF SIGNAL, THE RF SIGNAL ADJUST THE  
TRIMMER CAPACITOR (VC301).  
THE RF SIGNAL ENTER BY THE TRANSMISSION POWER  
AMP TRANSISTOR (Q301,Q302)  
THE SIGNAL IS AMPLITUDE IN THE TR Q301,302.  
ENTER BY THE BAND PASS FILTER.  
THE RF SIGNAL PASS THROUGH THE BAND PASS FILTER, TOWARDS THE ANT.  
THE LAST TRANSMISSION RF SIGNAL IS 902.125MHz□□903.100MHz

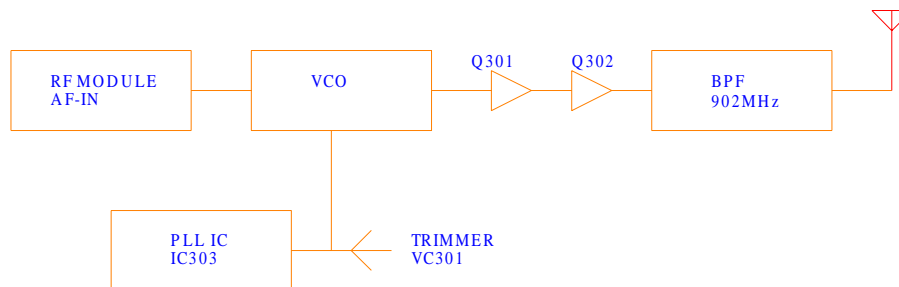

FIG. 11

## B. PORTABLE UNIT

### 1. LOW BATTERY DETECTION CIRCUIT

TRANSISTOR Q7,Q8 IS CONTROLLED BY BATTERY VOLTAGE.  
IF THE VOLTAGE OF BATTERY PACK IS BELOW 3.3V, CHANGED FROM HIGH TO LOW AT PIN 19 OF CPU THEN CPU BECOMES TO RECOGNIZE TO LOW VOLTAGE OF BATTERY PACK

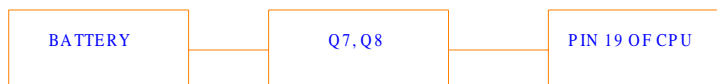

FIG.12

### 2. BUZZER

BUZZER IS CONTROLLED BY PIN 21, 22 OF CPU DURING RECEIVED RING SIGNAL AND KEY INPUT

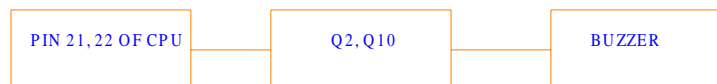

FIG.13

### 3. INDICATOR CATEGORY

IN USE/BATT LOW LED  
INUSE LED DRIVED BY PIN 40 OF CPU

#### 4. AUDIO AMPLIFIER AND COMPANDOR

##### 4-1 TX PART

THE TRANSMITTED SIGNALS FROM MIC ARE FEED TO COMPANDOR IC3 THROUGH AUDIO AMPLIFIER IC4B AND SIGNALS INPUT RF MODULE AF-IN

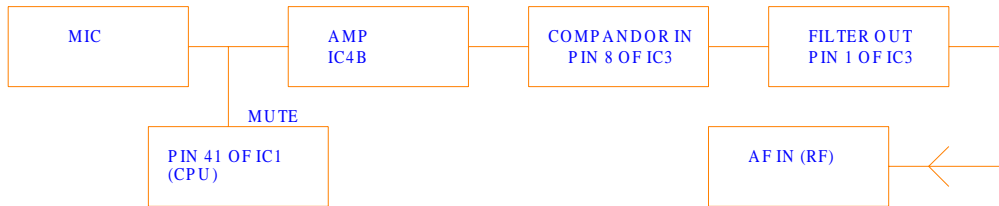

FIG. 14

##### 4-2 RX PART

THE RECEIVED SIGNALS FROM AF OUT CONTAIN SIGNALS AND PASS ONLY THROUGH COMPANDOR FOR NOISE ELIMINATION AND SIGNAL INPUT AUDIO AMPOLIFIER.

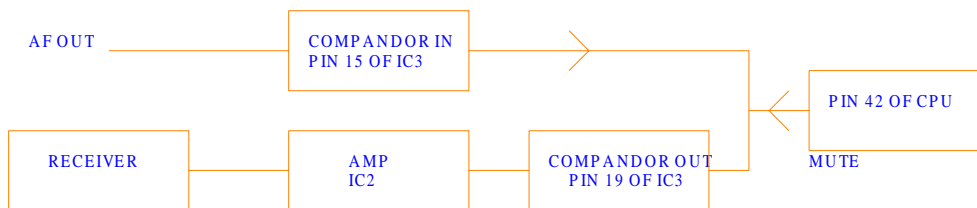

FIG. 15

## 5. PORTABLE RF MODULE

### 5-1. RX PART

THE RECEIVER FRONT-END CONTAINS A BAND PASS FILTER, AND RF LOW NOISE AMPLIFIER, A ACTIVE TRANSISTOR MIXER, A MONOLITHIC CRYSTAL FILTER AND 10.7MHz IF AMPLIFIER. ALSO IT INCLUDES BUFFER AMPLIFIERS OR THE GENERATION OF LOCAL OSCILATOR POWER.

THIS FRONT-END RECEIVES AN RF SIGNAL FROM THE ANTENNA.

AND RF SIGNALS WITHIN THIS FREQUENCY RANGE IS 902.125MHz-903.100MHz PASS THROUGH RF AMP (Q306,Q303) AND BAND PASS FILTER.

AFTER PASSING THROUGH THE BAND PASS FILTER, THE SIGNAL IS MIXED WITHIN 1ST LOCAL FREQUENCY FROM VOLTAGE CONTROLLED OSCILLATOR.

THE SIGNAL IS AMPLIFIED ON THE IF AMP TRANSISTOR (Q305)

AND THE SIGNAL PASS THROUGH THE MONOLITHIC CRYSTAL FITER (10.7MHz)

AFTER THE IF SIGNAL PASS THE MCF FILTER, THE SIGNAL ENTER BY THE FM IF (INTERMEDIATE FREQUENCY) IC.

AND THE SIGNAL IS MIXED IN THE FMIF IC (DBL5018).

THE SIGNAL PASS THROUGH THE CERAMIC FILTER (450KHz).

THE OUTPUT SIGNAL IN THE FMIF IC STREAMS FROM THE AF-OUT TERMINAL OF THE CONNECTOR 1 TO THE PORTABLE MAIN.

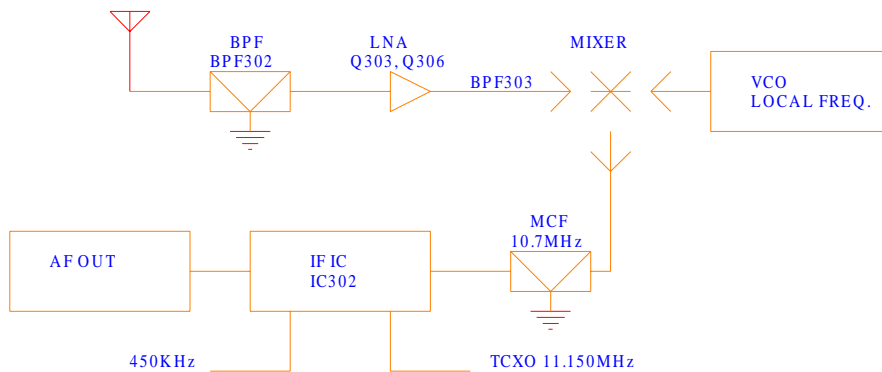

FIG. 16

## 5-2. TX PART

THE SIGNAL IS MADE TO THE PORTABLE, ENTER BY THE AF-IN TERMINAL.

THE SIGNAL SEND THE MOD TERMINAL OF THE TX VCO.

THE SIGNAL IS MIXED IN THE TX VCO

MIXING THE RF SIGNAL, THE RF SIGNAL ADJUST THE TRIMMER CAPACITOR (VC301).

THE RF SIGNAL ENTER BY THE TRANSMISSION POWER AMP TRANSISTOR (Q301,Q302)

THE SIGNAL IS AMPLITUDE IN THE Q301,Q302.

ENTER BY THE BAND PASS FILTER.

THE RF SIGNAL PASS THROUGH THE BAND PASS FILTER, TOWARDS THE ANT.

THE LAST TRANSMISSION RF SIGNAL IS 926.125MHz□□927.100MHz.

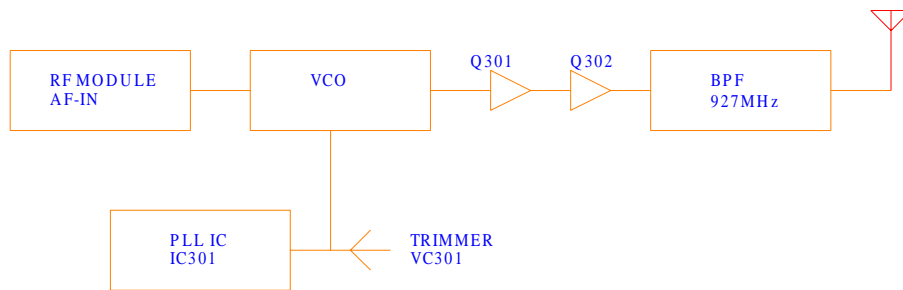

FIG. 17