

Exhibit 6: Test Report

TEST REPORT FROM:

COMMUNICATION CERTIFICATION LABORATORY
1940 W. Alexander Street
Salt Lake City, Utah
84119-2039

Type of Report: Certification

TEST OF: NQE1005

FCC ID: NQE1005

To FCC PART 15.247, Subpart C

Test Report Serial No: 73-6560

Applicant:

World Wireless Communications Inc.
150 Wright Brothers Drive, Suite 560
Salt Lake City, UT 84116

Date(s) of Test: March 17, 1998

Issue Date: July 7, 1998

Equipment Receipt Date: March 17, 1998

CERTIFICATION OF ENGINEERING REPORT

This report has been prepared by Communication Certification Laboratory to determine compliance of the device described below with the requirements of FCC PART 15.247, Subpart C. This report may be reproduced in full, partial reproduction may only be made with the written consent of the laboratory. The results in this report apply only to the sample tested.

- Applicant: World Wireless Communications Inc.
- Manufacturer: World Wireless Communications Inc.
- Brand Name: TIM
- Model Number: NQE1005
- FCC ID: NQE1005

On this 7th day of July 1998, I, individually, and for Communication Certification Laboratory, certify that the statements made in this engineering report are true, complete, and correct to the best of my knowledge, and are made in good faith.

COMMUNICATION CERTIFICATION LABORATORY

Checked by: William S. Hurst, P.E.
Vice President

Tested by: Roger J. Midgley
EMC Manager

SECTION 1. CLIENT INFORMATION AND RESPONSIBLE PARTY:

1.1 Client Information:

Company Name: World Wireless Communications Inc.
150 Wright Brothers Drive, Suite 560
Salt Lake City, UT 84116

Contact Name: George Field
Title:
Department:

SECTION 2. EQUIPMENT UNDER TEST (EUT)**2.1 Identification of EUT:**

Trade Name: TIM
Model Name or Number: NQE1005
Serial Number: N/A
Options Fitted: None
Country of Manufacture: U.S.A.

2.2 Description of EUT:

This report covers the transmitter only the receiver is covered under a separate notification report.

The NQE1005 is a frequency hopping transmitter that is installed inside a gas meter or similar device. While in "sleep" mode it monitors the switch closures on pins 1 and 6 of connector JP2 (from the meter). These switch closures will be accumulated after a preprogrammed number of pulses (1 to 10,000 set during installation). A data packet containing the total counts is transmitted to a receiver station using Frequency Shift Keying (FSK) modulation. This transmission will be on 1 of 25 different frequency channels ranging from 902 to 928 MHz and will transmit for approximately 35 msec. After a packet of data has been transmitted, the transmitter will return to "sleep" mode to collect another packet of data.

The above process will then be repeated (at the next frequency in the hop chart) once a complete data packet has been collected. All 25 transmit frequencies will be used before any given frequency is repeated. The amount of time that the NQE1005 will be in "sleep" mode will be at least one second, this will guarantee that any given frequency will not be used again for a minimum of 25 seconds.

The NQE1005 is the companion to the NQE1002 Receiver from World Wireless Communications. This receiver fast scans all twenty five channels listed in the hopping table. If, valid data is detected from one of the Transmitters it stays on that channel long enough to accept an entire packet of data. The on board processor then passes the data out to a data collection system and continues to scan for the next transmitter. After each transmission the transmitters advances to the next frequency in the hopping table. When the input count is reached a new packet is sent. This completes the cycle.

Enclosed below is a system diagram showing how the NQE1005

will be used in the complete World Wireless system.

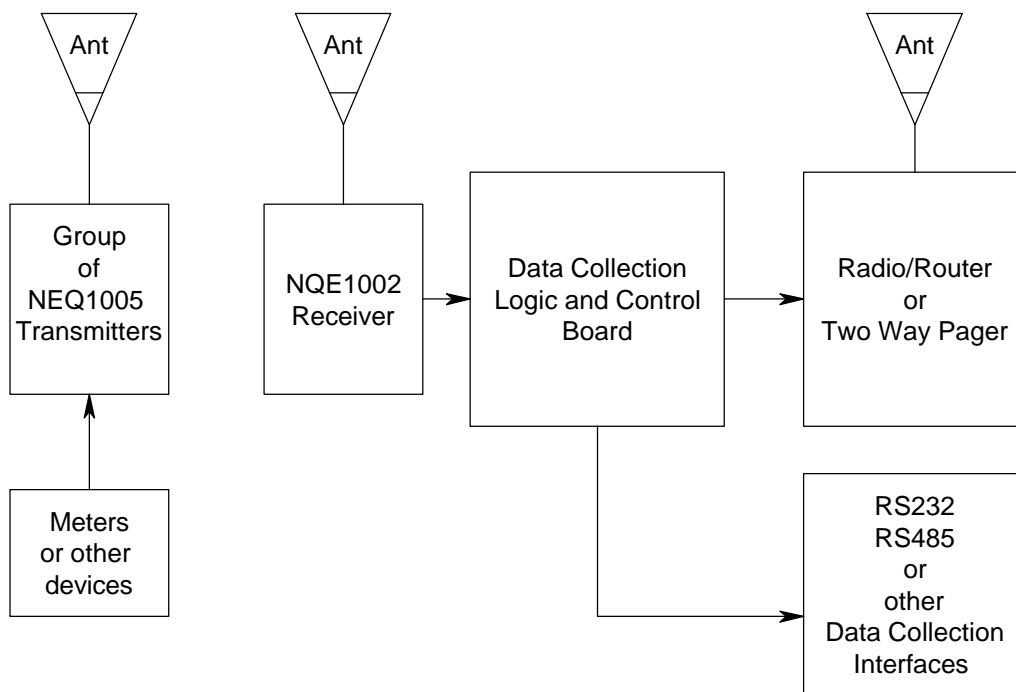

2.3 Modification Incorporated/Special Accessories on EUT:

There were no modifications or special accessories required to comply with the specification.

SECTION 3. TEST SPECIFICATION, METHODS & PROCEDURES**3.1 Test Specification:**

Title: FCC PART 15.247, Subpart C (47 CFR 15).

Limits and methods of measurement of radio interference characteristics of radio frequency devices. Operation within the bands 902-928 MHz, 2400-2483.5 MHz and 5725-5850 MHz.

Purpose of Test: The tests were performed to demonstrate Initial compliance.

3.2 Methods & Procedures:**3.2.1 § 15.247**

(a) Operation under the provisions of this section is limited to frequency hopping and direct sequence spread spectrum intentional radiators that comply with the following provisions:

(1) Frequency hopping systems shall have hopping channel carrier frequencies separated by a minimum of 25 kHz or the 20 dB bandwidth of the hopping channel, whichever is greater. The system shall hop to channel frequencies that are selected at the system hopping rate from a pseudorandomly ordered list of hopping frequencies. Each frequency must be used equally on the average by each transmitter. The system receivers shall have input bandwidths that match the hopping channel bandwidths of their corresponding transmitters and shall shift frequencies in synchronization with the transmitting signals.

(i) Frequency hopping systems operating in the 902 - 928 MHz band shall use at least 50 hopping frequencies. The maximum allowed 20 dB bandwidth of the hopping channel is 500 kHz. The average time of occupancy on any frequency shall not be greater than 0.4 seconds within a 20 second period.

(ii) Frequency hopping systems operating in the 2400 - 2483.5 MHz and the 5725 - 5850 MHz bands shall use at least 75 hopping frequencies. The maximum allowed 20 dB bandwidth of the hopping channel is 1 MHz. The average time of occupancy on any frequency shall not be greater than 0.4 seconds within a 30 second period.

(2) For direct sequence systems, the minimum 6 dB bandwidth shall be at least 500 kHz.

(b) The maximum peak output power of the transmitter shall not exceed 1 watt. If transmitting antennas of directional gain greater than 6 dBi are used, the power shall be reduced by the amount in dB that the directional gain of the antenna exceeds 6 dBi.

(c) In any 100 kHz bandwidth outside these frequency bands, the radio frequency power that is produced by the modulation products of the spreading sequence, the information sequence and the carrier frequency shall be either at least 20 dB below that in any 100 kHz bandwidth within the band that contains the highest level of the desired power or shall not exceed the general levels specified in § 15.209 (a), whichever results in the lesser attenuation. All other emissions outside these bands shall not exceed the general radiated emission limits specified in § 15.209 (a).

(d) For direct sequence system, the transmitted power density averaged over any 1 second interval shall not be greater than 8 dBm in any 3 kHz bandwidth within these bands.

(e) The processing gain of a direct sequence system shall be at least 10 dB. The processing gain shall be determined from the ratio in dB of the signal to noise ratio with the system spreading code turned off to the signal to noise ratio with the system spreading code turned on, as measured at the demodulated output of the receiver.

(f) Hybrid systems that employ a combination of both direct sequence and frequency hopping modulation techniques shall achieve a processing gain of at least 17 dB from the combined techniques. The frequency hopping operation of the hybrid system, with the direct sequence operation turned off, shall have an average time of occupancy on any frequency not to exceed 0.4 seconds within a time period equal to the number of hopping frequencies employed multiplied by 0.4. The direct sequence operation of the hybrid system, with the frequency hopping operation turned off, shall comply with the power density requirements of paragraph (d) of this section.

NOTE: Spread spectrum systems are sharing these bands on a non-interference basis with systems supporting critical Government requirements that have been allocated the usage of these bands, secondary only to ISM equipment operated under the provisions of part 18 of this chapter. Many of these Government systems are airborne radiolocation

systems that emit a high EIRP, which can cause interference to other users. Also, investigations of the effect of spread spectrum interference to U.S. Government operations in the 902-928 MHz band may require a future decrease in the power limits allowed for spread spectrum operation.

3.2.2 § 15.207 Conducted Limits

(a) For an intentional radiator which is designed to be connected to the public utility (AC) power line, the radio frequency voltage that is conducted back onto the AC power line on any frequency or frequencies within the band 450 kHz to 30 MHz shall not exceed 250 microvolts. Compliance with the provision shall be based on the measurement of the radio frequency voltage between each power line and ground at the power terminals.

(b) The following option may be employed if the conducted emissions exceed the limits in paragraph (a) of this section when measured using instrumentation employing a quasi-peak detector function: If the level of the emission measured using the quasi-peak instrumentation is 6 dB, or more, higher than the level of the same emission measured with instrumentation having an average detector and a 9 kHz minimum bandwidth, that emission is considered broadband and the level obtained with the quasi-peak detector may be reduced by 13 dB for comparison to the limits. When employing this option, the following conditions shall be observed:

(1) The measuring instrumentation with the average detector shall employ a linear IF amplifier.

(2) Care must be taken not to exceed the dynamic range of the measuring instrument when measuring an emission with a low duty cycle.

(3) The test report required for verification of for an application for a grant of equipment authorization shall contain all details supporting the use of this option.

(c) The limit shown in paragraph (a) of this section shall not apply to carrier current systems operation as intentional radiators on frequencies below 30 MHz. In lieu thereof, these carrier current systems shall be subject to the following standards:

(1) For carrier current systems containing their fundamental emission within the frequency band 535-1705 kHz and intended to

be received using a standard AM broadcast receiver: no limit on conducted emissions.

(2) For all other carrier current systems: 1000 μ V within the frequency band 535-1705 kHz.

(3) Carrier current systems operating below 30 MHz are also subject to the radiated emission limits in §§ 15.205, 15.209, 15.221, 15.223, 15.225 or 15.227, as appropriate.

(d) Measurements to demonstrate compliance with the conducted limits are not required for devices which only employ battery power for operation and which do not operate from the AC power lines or contain provisions for operation while connected to the AC power lines. Devices that include, or make provision for, the use of battery chargers which permit operation while charging, AC adapters or battery eliminators or that connect to the AC power lines indirectly, obtaining their power through another device which is connected to the AC power lines, shall be tested to demonstrate compliance with the conducted limits.

3.2.3 Test Procedure

The testing was performed according to the procedures in ANSI C63.4 (1992). Testing was performed at CCL's Wanship open area test site #2, located at 550 West Wanship Road, Wanship, UT. This site has been fully described in a report submitted to the FCC, and was accepted in a letter dated October 29, 1997 (31040/SIT).

CCL participates in the National Voluntary Laboratory Accreditation Program (NVLAP) and has been accepted under NVLAP Lab Code:100272-0, which is effective until September 30,1998.

For radiated emissions testing that is performed at distances closer than the specified distance, an inverse proportionality factor of 20 dB per decade is used to normalize the measured data for determining compliance.

SECTION 4. OPERATION OF EUT DURING TESTING.**4.1 Operating Environment:**

Power Supply: 3.6 VDC (Lithium battery)
AC Mains Frequency: N/A

4.2 Operating Modes:

Each mode of operation was exercised to produce worst case emissions. The worst case emissions were with the NQE1005 running in the following mode. The NQE1005 was placed in the transmit mode with the same type of modulation that would normally be used during normal operation.

The NQE1005 operates on 3.6 VDC supplied via Lithium batteries; therefore, line conducted emission testing is not required.

4.3 Configuration & Peripherals:

The NQE1005 was placed on the table in the transmit mode with the same type of modulation that would normally be used during normal operation.

SECTION 5. SUMMARY OF TEST RESULTS:**5.1 FCC PART 15.247, Subpart C****5.1.1 Summary of Tests:**

| Section | Test Performed | Frequency Range (MHz) | Result |
|------------------|--|------------------------------|----------------|
| 15.247 (a)(1) | Hopping Channel Carrier Frequencies | 902 to 928 | Complied |
| 15.247 (a)(1)(i) | Emission Bandwidth | 902 to 928 | Complied |
| 15.247 (b)(2) | Peak Output Power | 902 to 928 | Complied |
| 15.247 (C) | Antenna Conducted Spurious Emissions | 30 to 10,000 | Complied |
| 15.247 (C) | Radiated Spurious Emissions | 30 to 10,000 | Complied |
| 15.207 | Line Conducted Emissions (Hot Lead to Ground) | 0.45 to 30 | Not Applicable |
| 15.207 | Line Conducted Emissions (Neutral Lead to Ground) | 0.45 to 30 | Not Applicable |

5.2 Result

In the configuration tested, the EUT complied with the requirements of the specification.

SECTION 6. MEASUREMENTS, EXAMINATIONS AND DERIVED RESULTS:**6.1 General Comments:**

This section contains the test results only. Details of the test methods used, etc., can be found in Appendix 1 of this report.

6.2 Test Results**6.2.1 § 15.247 (a) (1)****Demonstration of Compliance:**

See Exhibit 12.

6.3.2 § 15.247 (a) (1) (i)**Demonstration of Compliance:**

The NQE1005 uses the 902 MHz to 928 MHz band, which is divided into 25 channels, separated by 400 kHz.

The NQE1005 remains in "sleep" mode until it accumulates a preprogrammed number of pulses (1 to 10,000 set during installation). Once the preprogrammed number of pulses has been accumulated the NQE1005 transmits its data, the duration of this transmission was measured to be 37.6 msec (see plot in Appendix 2). After this packet of data has been transmitted, the transmitter will return to "sleep" mode to collect another packet of data.

The above process will then be repeated (at the next frequency in the hop chart, see Exhibit 12) once the next data packet has been collected. All 25 transmit frequencies will be used before any given frequency is repeated. The amount of time that the NQE1005 will be in "sleep" mode will be a minimum of one second, this guarantees that any given frequency will not be used again for a minimum of 25 seconds.

Therefore, the total average time of occupancy on any frequency within a 10 second period is 37.6 msec. Since this is less than the 0.4 seconds allowed by the rules, the NQE1005 complies with this requirement.

Measurement Data Emission Bandwidth:

A diagram of the test configuration is enclosed list of the test equipment used is enclosed in Appendix 1.

| Frequency (MHz) | Measured Emission Bandwidth (kHz) |
|--------------------|---|
| 905.8 | 283.0 |
| 917.0 | 251.0 |
| 924.2 | 259.0 |

RESULT

In the configuration tested, the EUT complied with the requirements of the specification.

6.2.3 § 15.247 (b) (2) Peak Output Power:**Measurement Data:**

The maximum peak output power measured for this device was 81.3 milliwatt or 19.1 dBm (see plots in Appendix 2). Shown below is the measured peak output power.

A diagram of the test configuration is enclosed list of the test equipment used is enclosed in Appendix 1.

| Frequency (MHz) | Measured Output Power (dBm) | Measured Output Power (Milliwatt) |
|--------------------|--------------------------------|---|
| 905.8 | 18.4 | 69.2 |
| 917.0 | 18.9 | 77.6 |
| 924.2 | 19.1 | 81.3 |

RESULT

In the configuration tested, the EUT complied with the requirements of the specification.

6.2.4 § 15.247 (b) (3) Directional gain of antenna:**Measurement Data:**

The maximum directional gain of the system is less than 6 dBi; therefore, the maximum output power is not required to be reduced from the value measured.

RESULT

In the configuration tested, the EUT complied with the requirements of the specification.

6.2.5 § 15.247 (c) Spurious Emissions:**Measurement Data Antenna Conducted Emissions:**

The frequency range from 30 MHz to the tenth harmonic of the highest fundamental frequency was investigated to measure any antenna conducted emissions. Shown in Appendix 2 are plots of the upper and lower band edges with the NQE1005 tuned to the upper and lower channels respectively. These demonstrate compliance with the provisions of this section.

A diagram of the test configuration is enclosed list of the test equipment used is enclosed in Appendix 1.

The emissions must be attenuated 20 dB below the highest power level measured; therefore, the criteria is $18.4 - 20.0 = -1.6$ dBm.

| Transmitting at 905.8 MHz | | | |
|---------------------------|---------------|---------------------|--------------|
| Frequency Range MHz | Frequency MHz | Corrected Level dBm | Criteria dBm |
| 30 - 200 | 144.6 | -61.3 | -1.6 |
| 200 - 901.9 | 881.5 | -46.7 | -1.6 |
| 928.1 - 1000 | 929.5 | -49.1 | -1.6 |
| 1000 - 2000 | 1811.8 | -35.7 | -1.6 |
| 2000 - 3000 | 2717.6 | -47.1 | -1.6 |
| 3000 - 4000 | 3623.4 | -49.2 | -1.6 |
| 4000 - 5000 | 4529.0 | -49.2 | -1.6 |
| 5000 - 6000 | 5434.9 | -47.2 | -1.6 |
| 6000 - 7000 | 6340.7 | -41.3 | -1.6 |
| 7000 - 8000 | 7246.5 | -42.3 | -1.6 |
| 8000 - 9000 | 8152.1 | -42.2 | -1.6 |
| 9000 - 10000 | 9058.0 | -43.5 | -1.6 |
| * Noise Floor | | | |

The emissions must be attenuated 20 dB below the highest power level measured; therefore, the criteria is $18.9 - 20.0 = -1.1$ dBm.

| Transmitting at 917.0 MHz | | | |
|---------------------------|---------------|---------------------|--------------|
| Frequency Range MHz | Frequency MHz | Corrected Level dBm | Criteria dBm |
| 30 - 200 | 90.9 | -54.4 | -1.1 |
| 200 - 901.9 | 890.7 | -44.1 | -1.1 |
| 928.1 - 1000 | 939.5 | -45.8 | -1.1 |
| 1000 - 2000 | 1834.1 | -34.9 | -1.1 |
| 2000 - 3000 | 2751.1 | -45.6 | -1.1 |
| 3000 - 4000 | 3668.0 | -46.7 | -1.1 |
| 4000 - 5000 | 4584.8 | -45.5 | -1.1 |
| 5000 - 6000 | 5501.9 | -45.1 | -1.1 |
| 6000 - 7000 | 6418.9 | -40.6 | -1.1 |
| 7000 - 8000 | 7336.0 | -41.5 | -1.1 |
| 8000 - 9000 | 8253.0 | -41.7 | -1.1 |
| 9000 - 10000 | 9170.0 | -41.8 | -1.1 |
| * Noise Floor | | | |

The emissions must be attenuated 20 dB below the highest power level measured; therefore, the criteria is $19.1 - 20.0 = -0.9$ dBm.

| Transmitting at 924.2 MHz | | | |
|---------------------------|---------------|---------------------|--------------|
| Frequency Range MHz | Frequency MHz | Corrected Level dBm | Criteria dBm |
| 30 -200 | 157.5 | -44.3 | -0.9 |
| 200 - 901.9 | 901.1 | -40.1 | -0.9 |
| 928.1 - 1000 | 949.0 | -42.6 | -0.9 |
| 1000 - 2000 | 1848.3 | -34.5 | -0.9 |
| 2000 - 3000 | 2772.6 | -44.3 | -0.9 |
| 3000 - 4000 | 3696.8 | -47.5 | -0.9 |
| 4000 - 5000 | 4621.0 | -45.9 | -0.9 |
| 5000 - 6000 | 5545.2 | -46.7 | -0.9 |
| 6000 - 7000 | 6469.5 | -41.2 | -0.9 |
| 7000 - 8000 | 7393.7 | -42.4 | -0.9 |
| 8000 - 9000 | 8317.9 | -41.6 | -0.9 |
| 9000 - 10000 | 9242.0 | -42.1 | -0.9 |
| * Noise Floor | | | |

Measurement Data Radiated Emissions Restricted Bands § 15.205:

The frequency range from 30 MHz to 10 GHz was investigated to measure any radiated emissions in the restricted bands.

A diagram of the test configuration is enclosed list of the test equipment used is enclosed in Appendix 1.

Horizontal Polarity

| Transmitting at 905.8 MHz | | | | | |
|---------------------------|----------|-----------------------------------|----------------------------|--------------------------------------|-----------------------|
| Frequency MHz | Detector | Receiver Reading dB μ V | Correction Factor dB | Corrected Reading dB μ V/m | Limit dB μ V/m |
| 2717.4 | Peak | 19.6 | 32.6 | 52.2 | 74.0 |
| 2716.5 | Average | 10.5 | 32.6 | 43.1 | 54.0 |
| 3623.1 | Peak | 6.8 | 35.2 | 42.0 | 74.0 |
| 3622.0 | Average | -1.3 | 35.2 | 33.9 | 54.0 |
| 4529.0 | Peak | 7.0 | 35.7 | 42.7 | 74.0 |
| 4529.0 | Average | -1.4 | 35.7 | 34.3 | 54.0 |
| 5434.3 | Peak | 8.1 | 38.5 | 46.6 | 74.0 |
| 5434.3 | Average | -0.9 | 38.5 | 37.6 | 54.0 |
| 8152.2 | Peak | 8.1 | 42.0 | 50.1 | 74.0 |
| 8152.2 | Average | -1.6 | 42.0 | 40.4 | 54.0 |
| 9058.0 | Peak | 8.8 | 42.6 | 51.4 | 74.0 |
| 9058.0 | Average | -2.7 | 42.6 | 39.9 | 54.0 |

| Transmitting at 917.0 MHz | | | | | |
|---------------------------|----------|-----------------------------------|----------------------------|--------------------------------------|-----------------------|
| Frequency MHz | Detector | Receiver Reading dB μ V | Correction Factor dB | Corrected Reading dB μ V/m | Limit dB μ V/m |
| 2751.0 | Peak | 15.2 | 32.8 | 48.0 | 74.0 |
| 2751.0 | Average | 5.5 | 32.8 | 38.3 | 54.0 |
| 3668.0 | Peak | -1.0 | 35.5 | 34.5 | 74.0 |
| 3668.0 | Average | -3.2 | 35.5 | 32.3 | 54.0 |
| 4585.0 | Peak | 13.2 | 36.0 | 49.2 | 74.0 |
| 4585.0 | Average | 9.4 | 36.0 | 45.4 | 54.0 |
| 7336.0 | Peak | 6.5 | 40.4 | 46.9 | 74.0 |
| 7336.0 | Average | -1.4 | 40.4 | 39.0 | 54.0 |
| 8253.0 | Peak | -0.5 | 42.1 | 41.6 | 74.0 |
| 8253.0 | Average | -3.6 | 42.1 | 38.5 | 54.0 |
| 9170.0 | Peak | -1.2 | 42.8 | 41.6 | 74.0 |
| 9170.0 | Average | -3.7 | 42.8 | 39.1 | 54.0 |

| Transmitting at 924.2 MHz | | | | | |
|---------------------------|----------|-----------------------------------|----------------------------|--------------------------------------|-----------------------|
| Frequency MHz | Detector | Receiver Reading dB μ V | Correction Factor dB | Corrected Reading dB μ V/m | Limit dB μ V/m |
| 2772.7 | Peak | 21.7 | 32.8 | 54.5 | 74.0 |
| 2772.7 | Average | 10.9 | 32.8 | 43.7 | 54.0 |
| 3696.8 | Peak | 12.9 | 35.5 | 48.4 | 74.0 |
| 3696.8 | Average | 2.8 | 35.5 | 38.3 | 54.0 |
| 4621.0 | Peak | 12.2 | 36.1 | 48.3 | 74.0 |
| 4621.0 | Average | 2.6 | 36.1 | 38.7 | 54.0 |
| 7393.6 | Peak | 8.5 | 40.6 | 49.1 | 74.0 |
| 7393.6 | Average | -1.2 | 40.6 | 39.4 | 54.0 |
| 8317.8 | Peak | 8.0 | 42.2 | 50.2 | 74.0 |
| 8317.8 | Average | -1.9 | 42.2 | 40.3 | 54.0 |

Vertical Polarity

| Transmitting at 905.8 MHz | | | | | |
|---------------------------|----------|-----------------------------------|----------------------------|--------------------------------------|-----------------------|
| Frequency MHz | Detector | Receiver Reading dB μ V | Correction Factor dB | Corrected Reading dB μ V/m | Limit dB μ V/m |
| 2717.4 | Peak | 17.0 | 32.6 | 49.6 | 74.0 |
| 2716.5 | Average | 9.6 | 32.6 | 42.2 | 54.0 |
| 3623.1 | Peak | 13.3 | 35.2 | 48.5 | 74.0 |
| 3622.0 | Average | 4.2 | 35.2 | 39.4 | 54.0 |
| 4529.0 | Peak | 18.8 | 35.7 | 54.5 | 74.0 |
| 4529.0 | Average | 8.2 | 35.7 | 43.9 | 54.0 |
| 5434.3 | Peak | 16.7 | 38.5 | 55.2 | 74.0 |
| 5434.3 | Average | 5.2 | 38.5 | 43.7 | 54.0 |
| 8152.2 | Peak | 9.9 | 42.0 | 51.9 | 74.0 |
| 8152.2 | Average | 1.1 | 42.0 | 43.1 | 54.0 |
| 9058.0 | Peak | 9.0 | 42.6 | 51.6 | 74.0 |
| 9058.0 | Average | 0.5 | 42.6 | 43.1 | 54.0 |

| Transmitting at 917.0 MHz | | | | | |
|---------------------------|----------|-----------------------------------|----------------------------|--------------------------------------|-----------------------|
| Frequency MHz | Detector | Receiver Reading dB μ V | Correction Factor dB | Corrected Reading dB μ V/m | Limit dB μ V/m |
| 2751.0 | Peak | 18.9 | 32.8 | 51.7 | 74.0 |
| 2751.0 | Average | 7.8 | 32.8 | 40.6 | 54.0 |
| 3668.0 | Peak | -1.5 | 35.5 | 34.0 | 74.0 |
| 3668.0 | Average | -3.2 | 35.5 | 32.3 | 54.0 |
| 4585.0 | Peak | 14.9 | 36.0 | 50.9 | 74.0 |
| 4585.0 | Average | 5.6 | 36.0 | 41.6 | 54.0 |
| 7336.0 | Peak | 9.2 | 40.4 | 49.6 | 74.0 |
| 7336.0 | Average | 0.6 | 40.4 | 41.0 | 54.0 |
| 8253.0 | Peak | -0.4 | 42.1 | 41.7 | 74.0 |
| 8253.0 | Average | -3.6 | 42.1 | 38.5 | 54.0 |
| 9170.0 | Peak | -1.6 | 42.8 | 41.2 | 74.0 |
| 9170.0 | Average | -3.7 | 42.8 | 39.1 | 54.0 |

| Transmitting at 924.2 MHz | | | | | |
|---------------------------|----------|-----------------------------------|----------------------------|--------------------------------------|-----------------------|
| Frequency MHz | Detector | Receiver Reading dB μ V | Correction Factor dB | Corrected Reading dB μ V/m | Limit dB μ V/m |
| 2772.7 | Peak | 23.5 | 32.8 | 56.3 | 74.0 |
| 2772.7 | Average | 12.9 | 32.8 | 45.7 | 54.0 |
| 3696.8 | Peak | 13.3 | 35.5 | 48.8 | 74.0 |
| 3696.8 | Average | 3.8 | 35.5 | 39.3 | 54.0 |
| 4621.0 | Peak | 13.8 | 36.1 | 49.9 | 74.0 |
| 4621.0 | Average | 3.6 | 36.1 | 39.7 | 54.0 |
| 7393.6 | Peak | 9.0 | 40.6 | 49.6 | 74.0 |
| 7393.6 | Average | -1.2 | 40.6 | 39.4 | 54.0 |
| 8317.8 | Peak | 10.0 | 42.2 | 52.2 | 74.0 |
| 8317.8 | Average | -1.9 | 42.2 | 40.3 | 54.0 |

Sample Field Strength Calculation:

The field strength is calculated by adding the Correction Factor (Antenna Factor + Cable Factor), to the measured level from the receiver. The basic equation with a sample calculation is shown below:

FS = RA + CF - AF Where

FS = Field Strength

RA = Receiver Amplitude (Receiver Reading - Amplifier Gain)

CF = Correction Factor (Antenna Factor + Cable Factor)

AF = Average Factor

RESULT

In the configuration tested, the EUT complied with the requirements of the specification.

APPENDIX 1 TEST PROCEDURES AND TEST EQUIPMENT**Radiated Interference Emissions:**

The radiated emission from the transmitter was measured using a spectrum analyzer with a quasi-peak adapter for peak, quasi-peak and average readings. A preamplifier with a fixed gain of 30 dB was used to increase the sensitivity of the measuring instrumentation.

A biconilog antenna was used to measure the frequency range of 30 to 1000 MHz and a Double Ridge Guide Horn antenna was used to measure the frequency range 1 GHz to 10 GHz, at a distance of 3 meters from the EUT. The readings obtained by these antennas are correlated to the levels obtained with a tuned dipole antenna by adding antenna factors.

The configuration of the transmitter was varied to find the maximum radiated emission. The EUT was connected to the peripherals listed in Section 2.4 via the interconnecting cables listed in Section 2.5. These interconnecting cable were manipulated manually by a technician to obtain worst case radiated emissions. The transmitter was rotated 360 degrees, and the antenna height was varied from 1 to 4 meters to find the maximum radiated emission. Where there were multiple interface ports all of the same type, cables are either placed on all of the ports or cables added to these ports until the emissions do not increase by more than 2 dB.

Transmitters are measured on a non-conducting table one-meter above the ground plane. The table is placed on a turntable which is level with the ground plane. The turntable has slip rings, which supply AC power to the transmitter. For equipment normally placed on floors, the equipment shall be placed directly on the turntable.

| Type of Equipment | Manufacturer | Model Number | Serial Number |
|--------------------------------|-----------------|--------------------|---------------|
| Wanship Open Area Test Site #2 | CCL | N/A | N/A |
| Test Software | CCL | Radiated Emissions | Revision 1.3 |
| Spectrum Analyzer | Hewlett Packard | 8566B | 2332A02726 |
| Quasi-Peak Detector | Hewlett Packard | 8565A | 2043A00287 |
| Biconilog Antenna | EMCO | 3142 | 9601-1008 |

| Type of Equipment | Manufacturer | Model Number | Serial Number |
|---|-----------------|--------------|---------------|
| Double Ridged Guide Antenna | EMCO | 3115 | 2129 |
| 3 Meter Radiated Emissions Cable Wanship Site #2 | CCL | Cable K | N/A |
| 10 Meter Radiated Emissions Cable Wanship Site #2 | CCL | Cable L | N/A |
| Pre-Amplifier | Hewlett Packard | 8449B | 3008A00990 |
| Pre/Power-Amplifier | Hewlett Packard | 8447F | 3113A05161 |
| 6 dB Attenuator | Hewlett Packard | 8491A | 32835 |

All the equipment listed above is calibrated every 12 months by an independent calibration laboratory or by CCL personal following outlined calibration procedures.

R a d i a t e d E m i s s i o n s T e s t

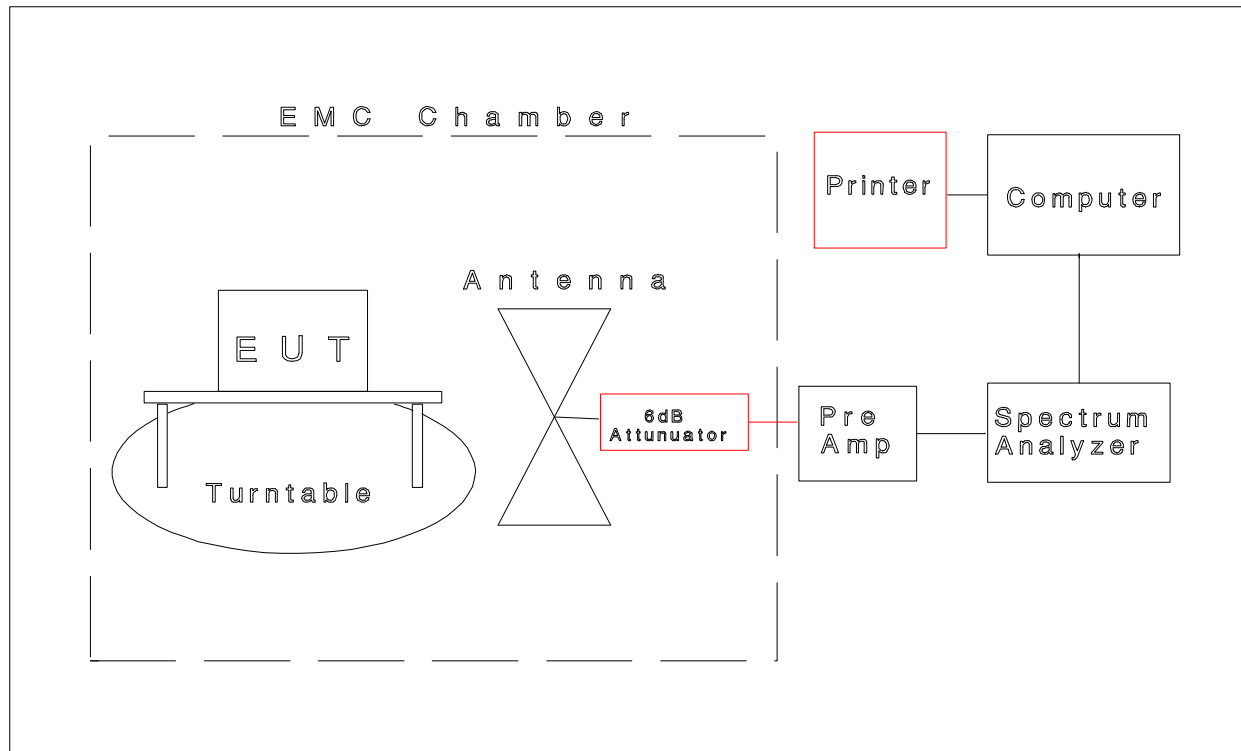

The spectrum analyzer's resolution bandwidth and video bandwidth were set as follows:

Peak Detection (30 - 1000 MHz)

RBW = 100 kHz

VBW = 300 kHz

Peak Detection (1 - 10 GHz)

RBW = 1 MHz

VBW = 3 MHz

Average Detection (1 - 10 GHz)

RBW = 1 MHz

VBW = 1 Hz

FCC Sections 15.247 Peak Transmit Power, Emission Bandwidth and Spurious Emissions (antenna conducted)

The EUT was directly connected to the spectrum analyzer via the antenna output port as shown in the block diagram below.

The measurements were performed on three channels, as per 47 CFR 15.31(m), one near the bottom of the spectrum, one near the middle of the spectrum and one near the top of the spectrum.

The spectrum analyzer's resolution bandwidth and video bandwidth were set as follows:

Peak Transmit Power

RBW = 100 kHz

VBW = 300 kHz

Emission Bandwidth

RBW = 10 kHz

VBW = 300 kHz

Spurious Emissions (Antenna Conducted)

RBW = 100 kHz - 30 MHz to 1000 MHz

VBW = 300 kHz

RBW = 1 MHz - 1 GHz to 10 GHz

VBW = 3 MHz

Test Configuration Block Diagram

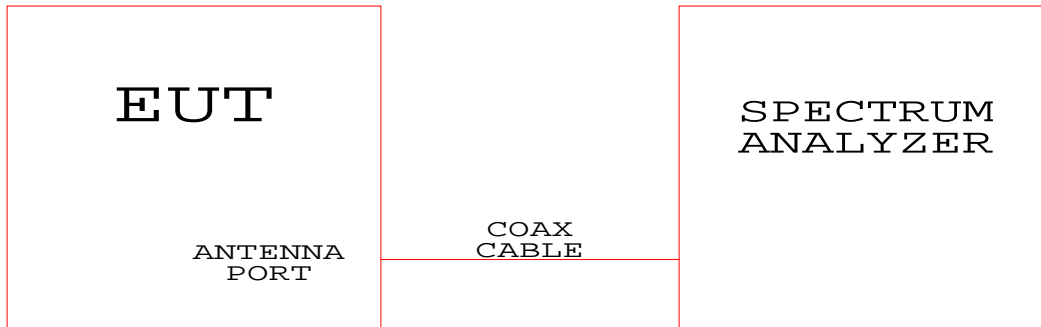

APPENDIX 2. SPECTRUM ANALYZER PLOTS:

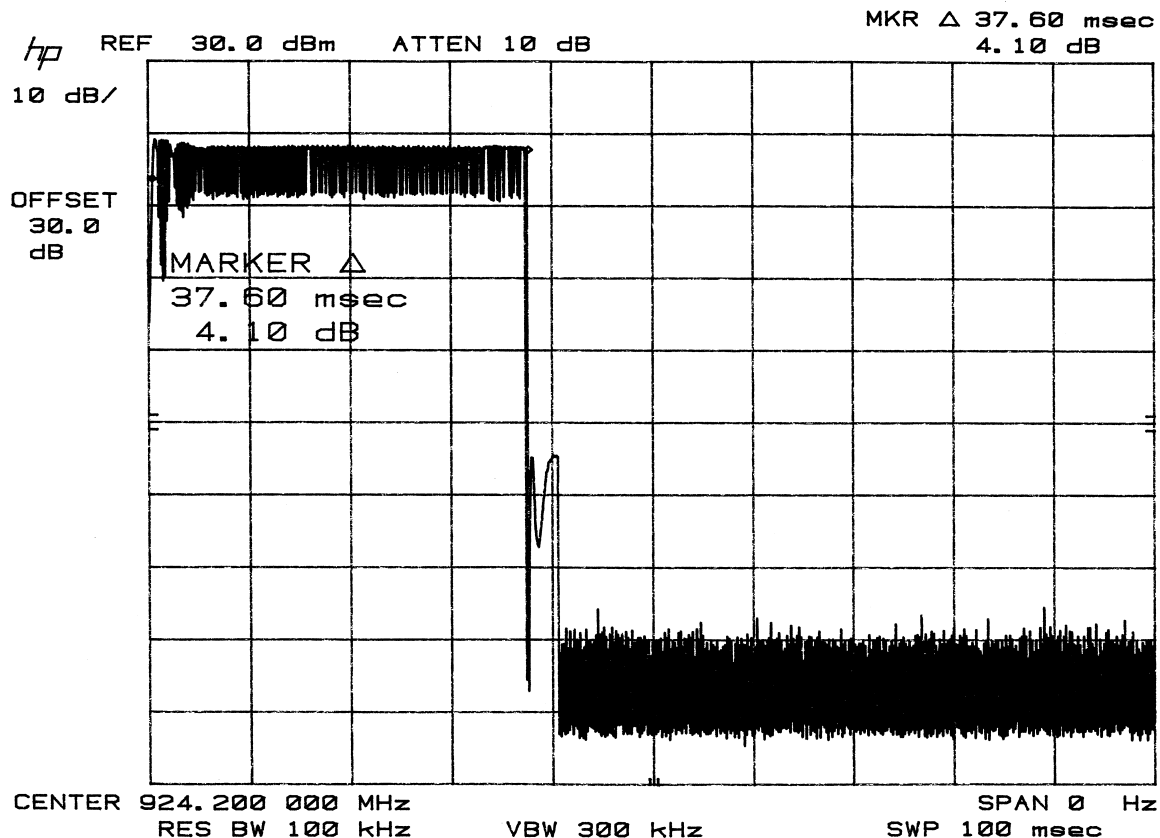

Plot showing duration of pulse

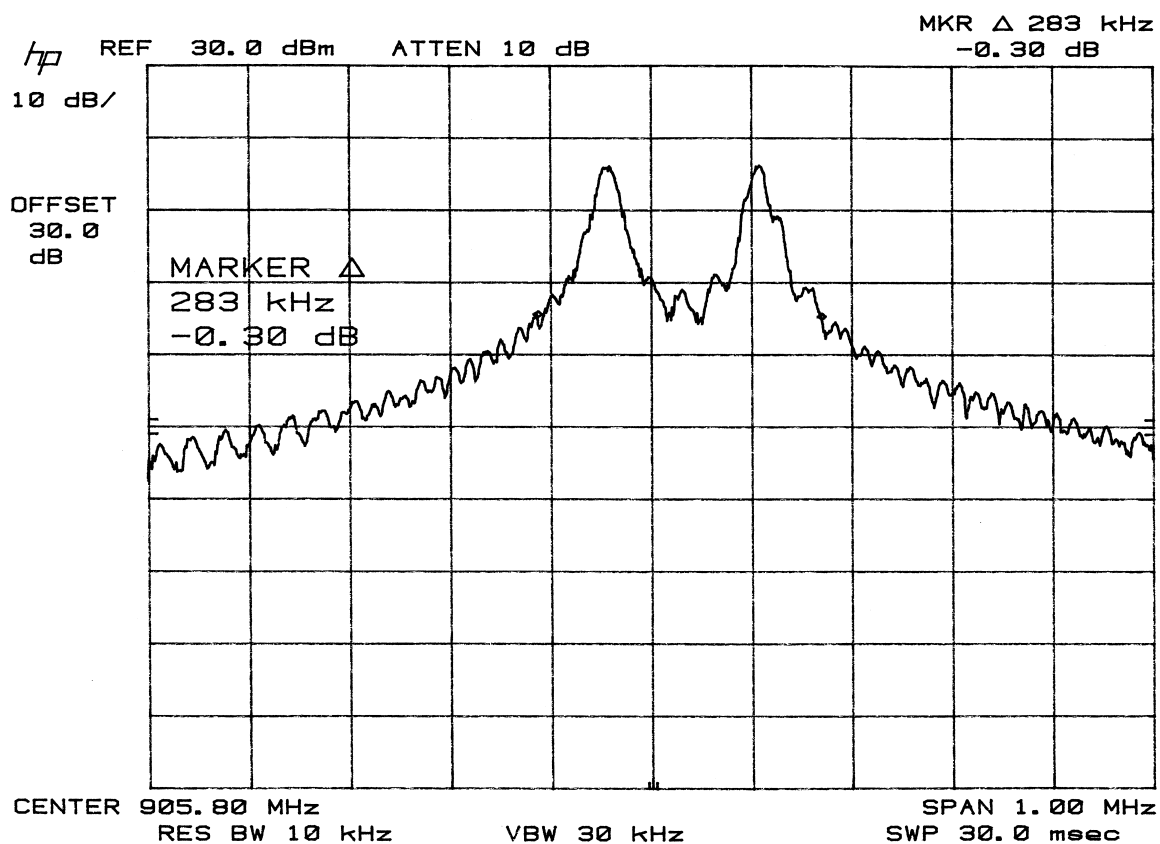

Occupied Bandwidth (Low end of band)

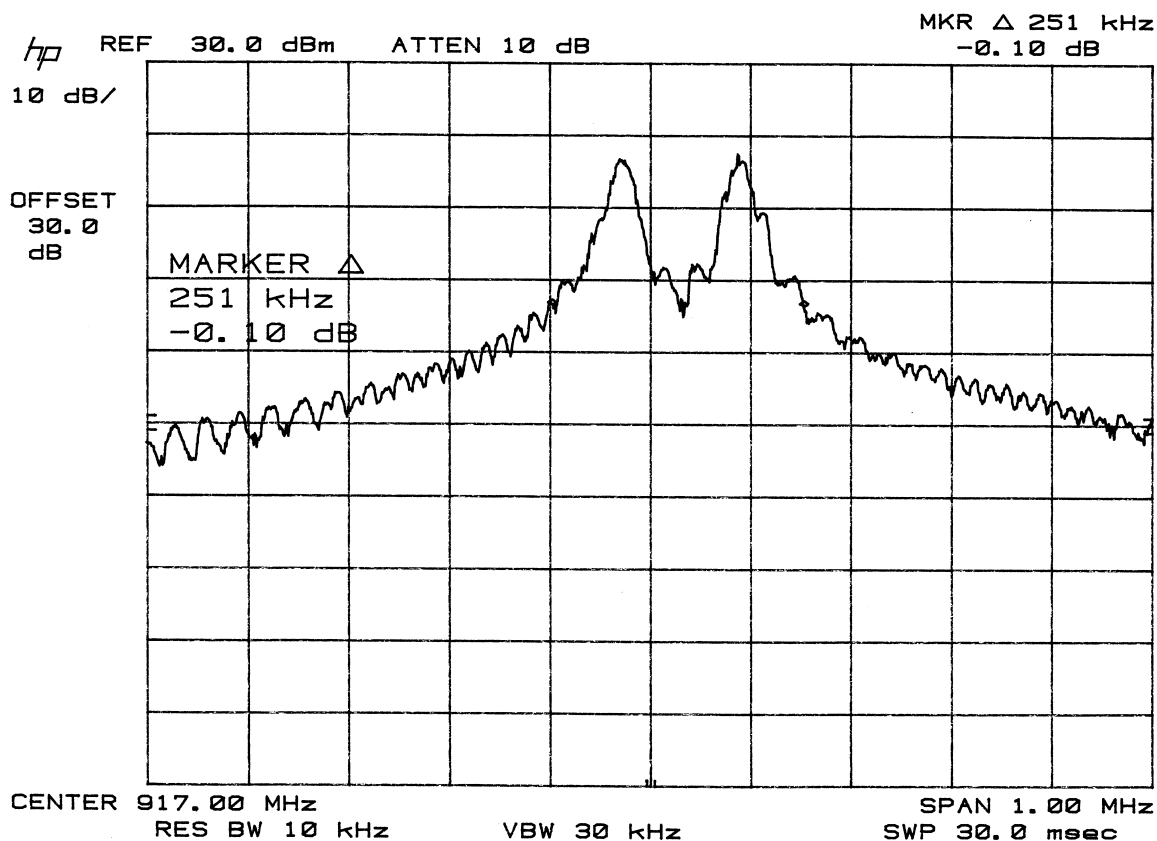

Occupied Bandwidth (Middle of band)

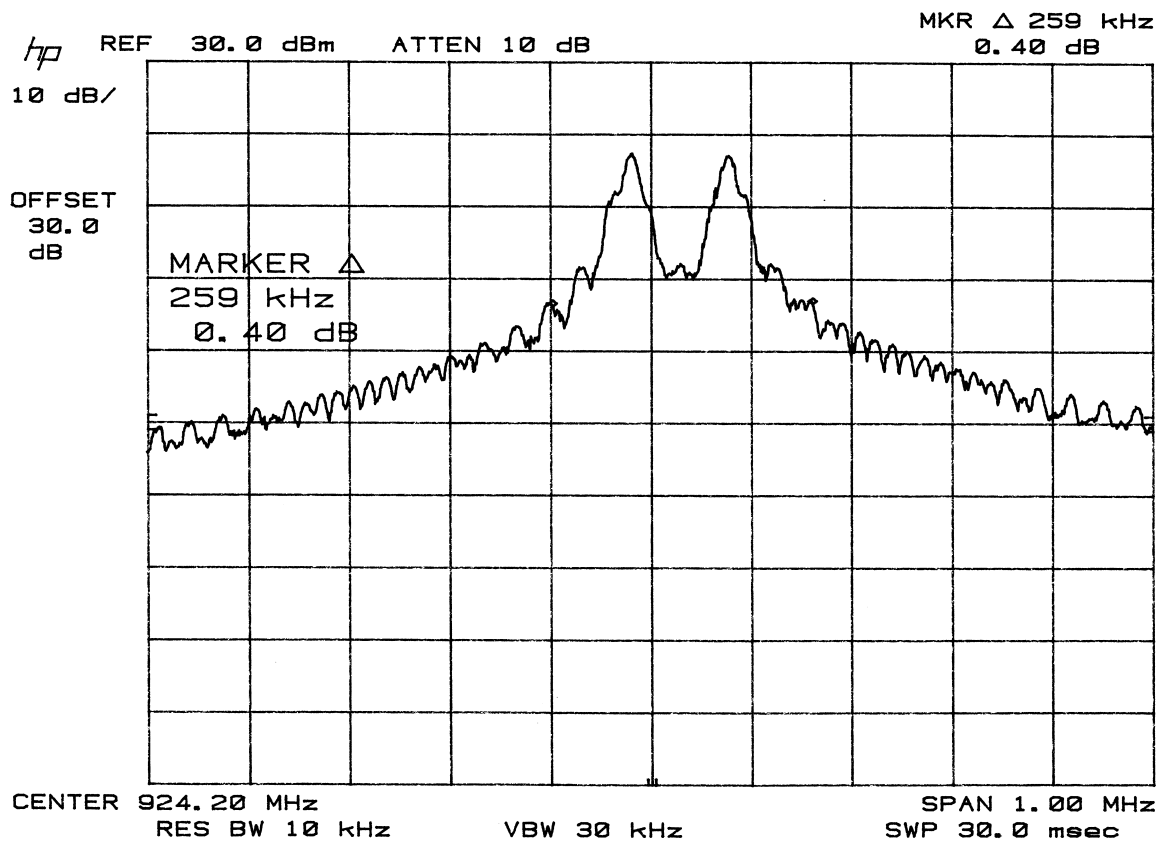

Occupied Bandwidth (High end of band)

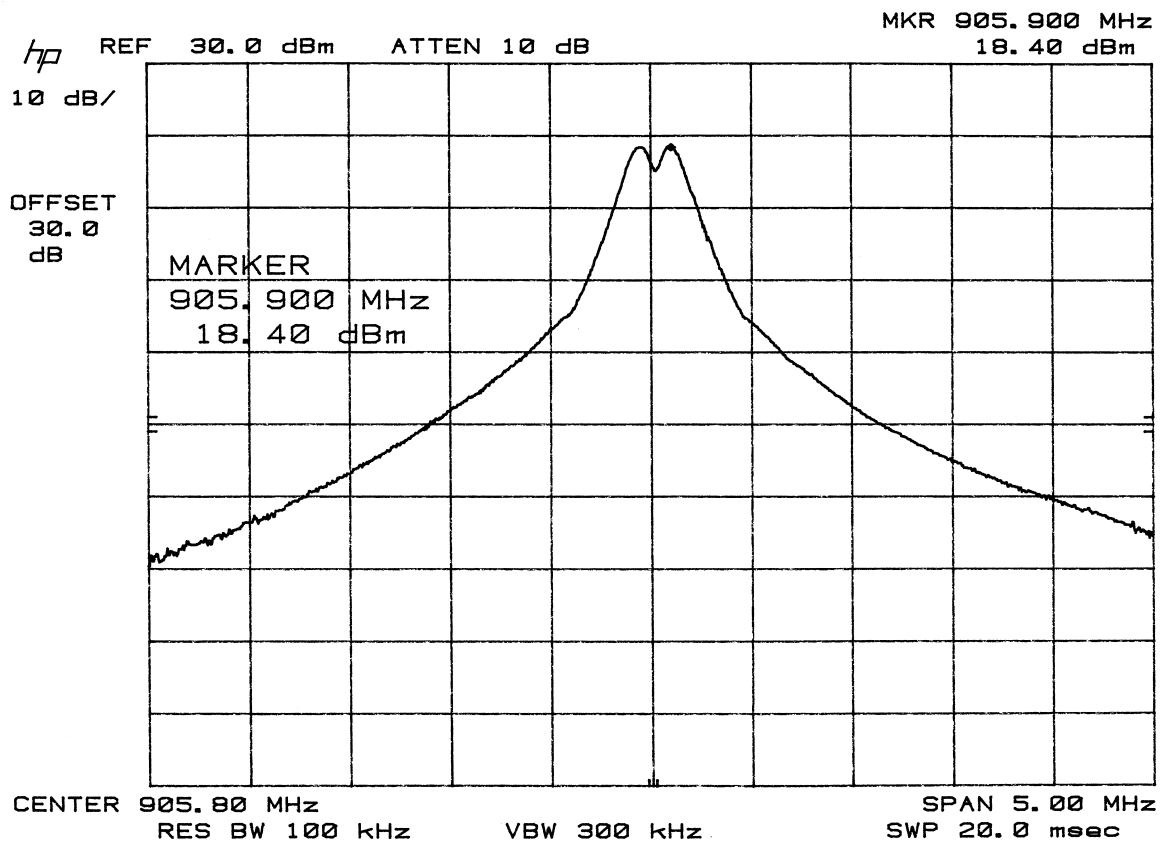

Output Power (Low end of band)

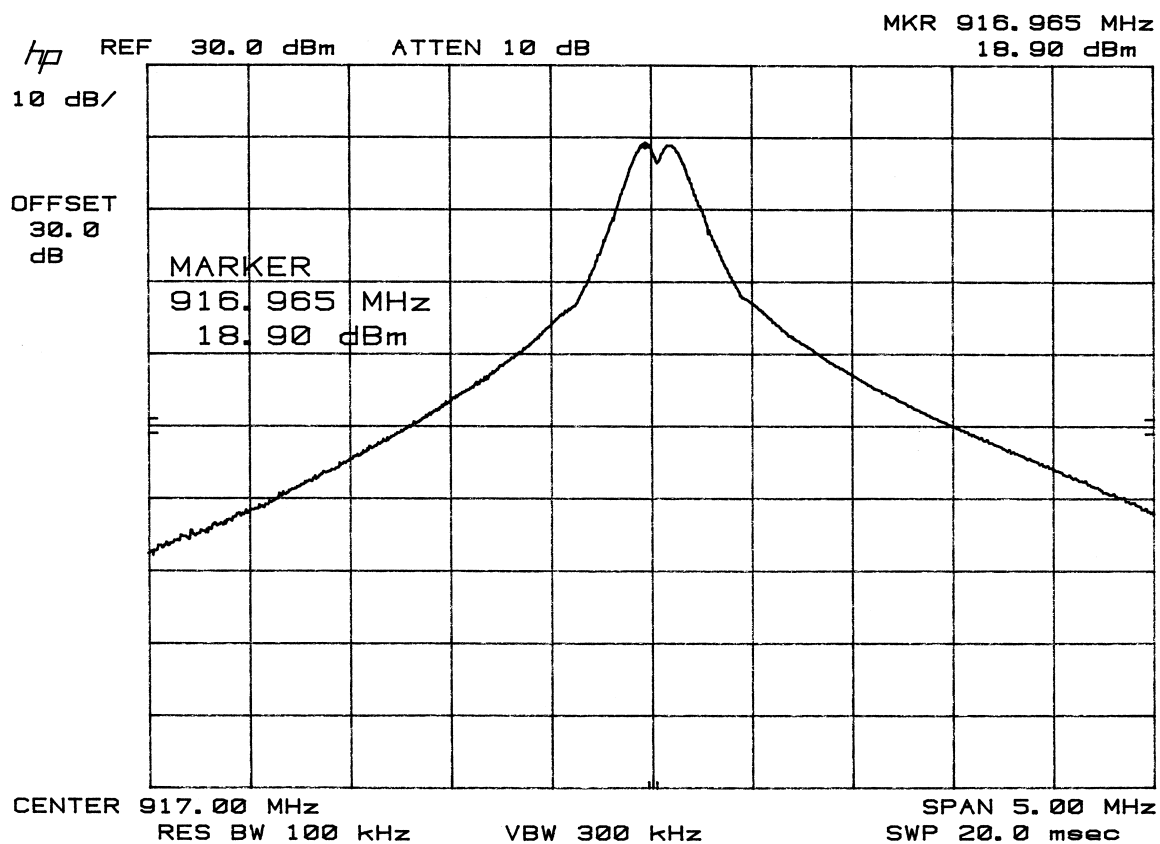

Output Power (Middle of band)

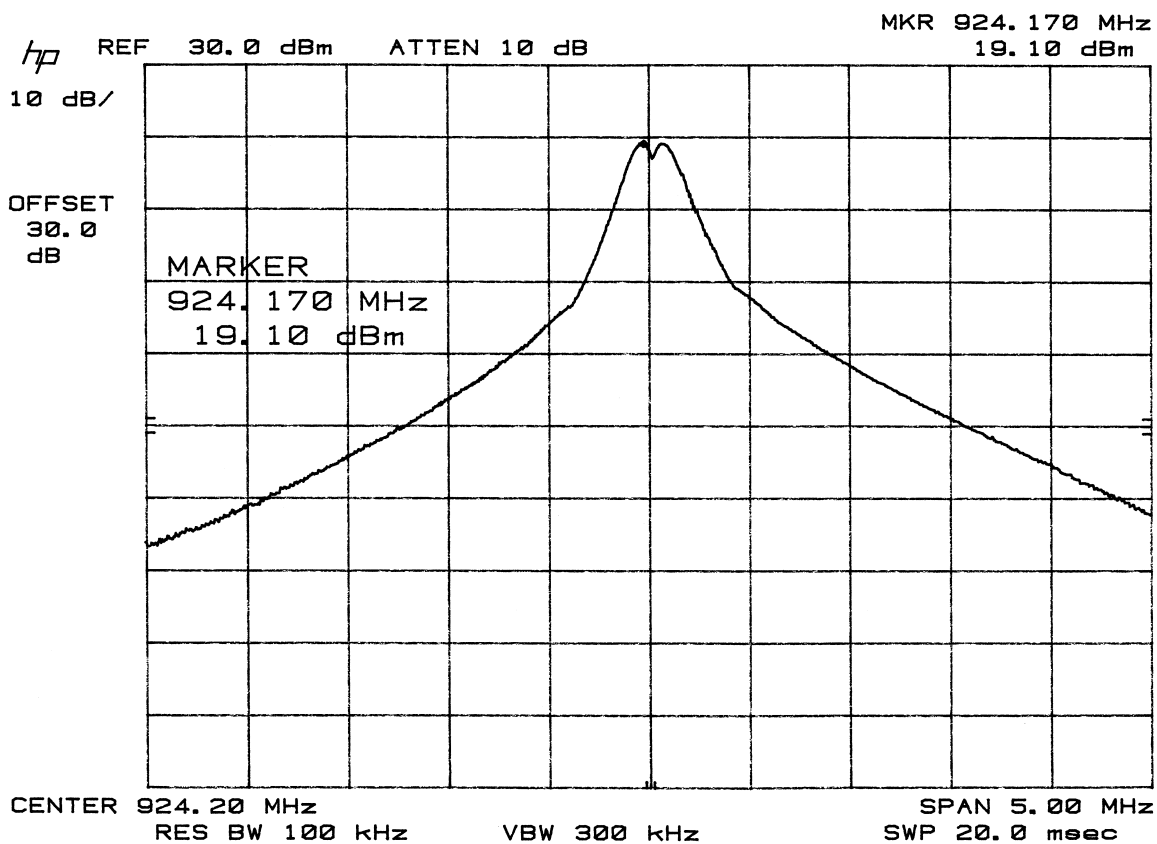

Output Power (High end of band)

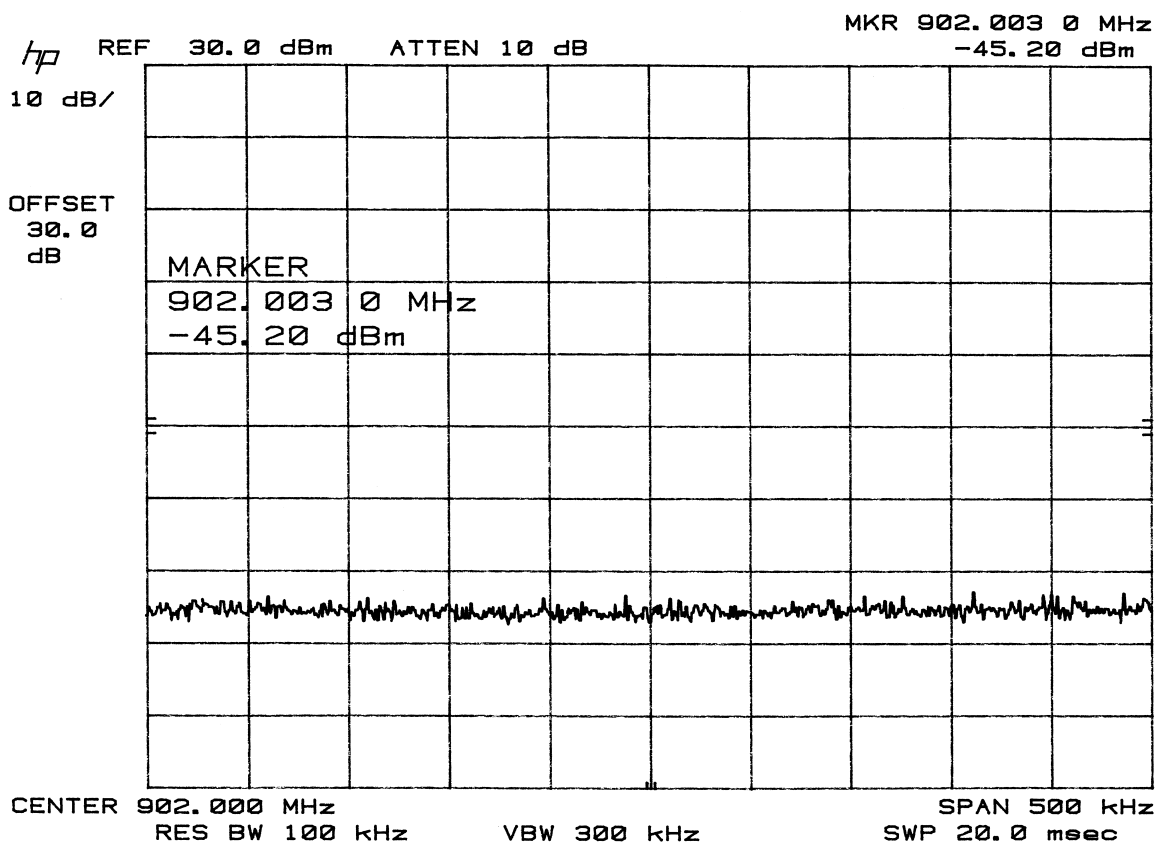

Conducted Spurious Emissions (Low end of band)
Transmitting at 905.8 MHz

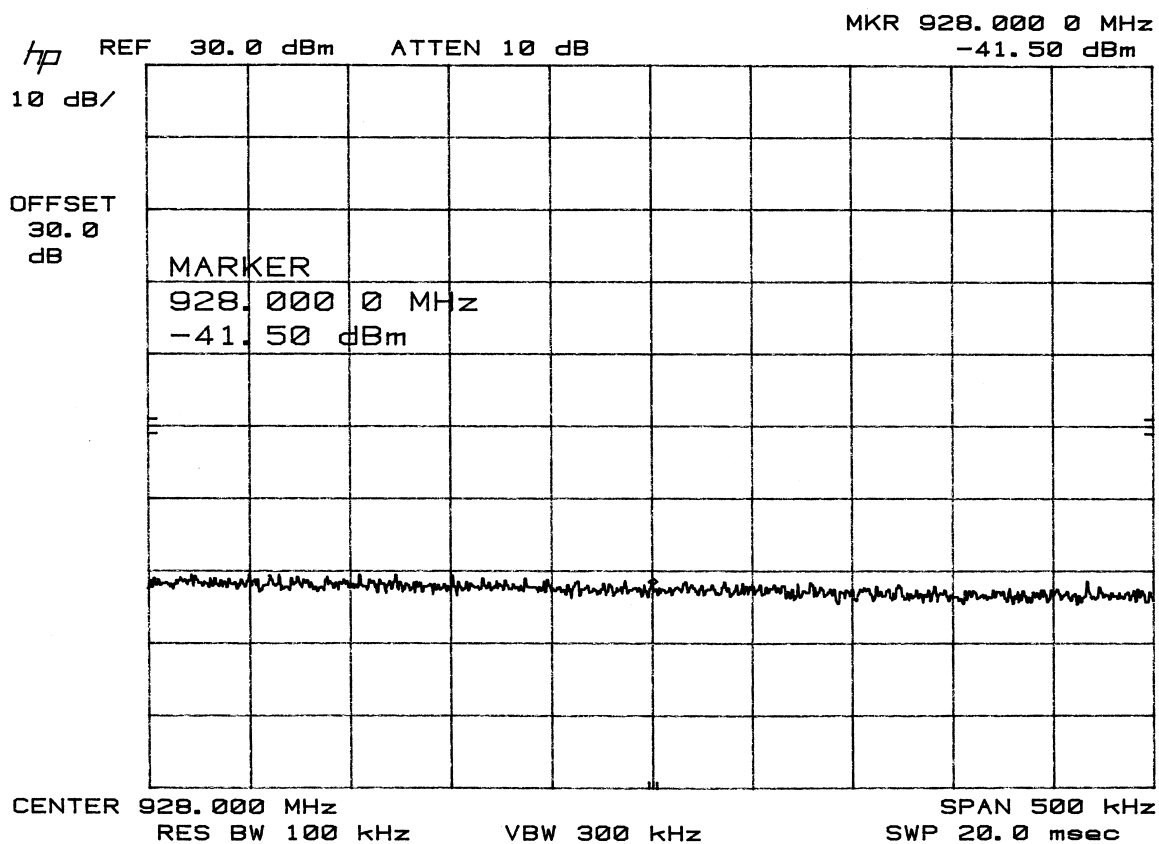

Conducted Spurious Emissions (High end of band)
Transmitting at 924.2 MHz