

Report on the Radio Testing  
For  
Pace plc  
on  
DOCSIS 3 HYBRID GATEWAY STB  
Report no. TRA-029714-47-01A  
4th May 2016

RF915 2.0

Report Number: TRA-029714-47-01A  
Issue: A

REPORT ON THE RADIO TESTING OF A  
Pace plc  
DOCSIS 3 HYBRID GATEWAY STB  
WITH RESPECT TO SPECIFICATION  
FCC 47CFR 15

TEST DATE: 1st October 2015 - 31st March 2016

Written by: D Winstanley

D Winstanley  
Radio Test Engineers

Approved by:

J Charters  
Department Manager - Radio

Date: 4th May 2016

Disclaimers:

- [1] THIS DOCUMENT MAY BE REPRODUCED ONLY IN ITS ENTIRETY AND WITHOUT CHANGE  
[2] THE RESULTS CONTAINED IN THIS DOCUMENT RELATE ONLY TO THE ITEM(S) TESTED

---

RF915 2.0

## 1 Revision Record

<i>Issue Number</i>	<i>Issue Date</i>	<i>Revision History</i>
A	4th May 2016	Original

## 2 Summary

TEST REPORT NUMBER: TRA-029714-47-01A

WORKS ORDER NUMBER: TRA-028175-00

PURPOSE OF TEST: USA: Testing of radio frequency equipment per the relevant authorization procedure of chapter 47 of CFR (code of federal regulations) Part 2, subpart J.

TEST SPECIFICATION(S): 47CFR15

EQUIPMENT UNDER TEST (EUT): DOCSIS 3 HYBRID GATEWAY STB

FCC IDENTIFIER: NQ8ND7507

EUT SERIAL NUMBER: FN34A152840077

MANUFACTURER/AGENT: Pace plc

ADDRESS: Victoria Road  
Saltaire  
Shipley  
West Yorkshire  
BD18 3LF  
United Kingdom

CLIENT CONTACT: Robert Turner  
☎ 01274 537080  
✉ robert.turner@pace.com

ORDER NUMBER: Not Applicable

TEST DATE: 1st October 2015 - 31st March 2016

TESTED BY: D Winstanley  
Element

## 2.1 Test Summary

<i>Test Method and Description</i>	<i>Requirement Clause 47CFR15</i>	<i>Applicable to this equipment</i>	<i>Result / Note</i>
Multi Radio Radiated spurious emissions	15.205, 15.247 (d), 15.407(b)(1/4/6)	☒	<i>Pass</i>
AC power line conducted emissions	15.207	☒	<i>Pass</i>

### **Notes:**

This report covers the DOCSIS 3 HYBRID GATEWAY STB when all radio device are transmitting simultaneously.

The results contained in this report relate only to the items tested, in the condition at time of test, and were obtained in the period between the date of initial receipt of samples and the date of issue of the report.

The apparatus was set up and exercised using the configurations, modes of operation and arrangements defined in this report only. Any modifications made are identified in Section 8 of this report.

Particular operating modes, apparatus monitoring methods and performance criteria required by the standards tested to have been performed except where identified in Section 5.2 of this test report (Deviations from Test Standards).

### 3 Contents

1	Revision Record.....	3
2	Summary.....	4
2.1	Test Summary.....	5
3	Contents.....	6
4	Introduction.....	7
5	Test Specifications.....	8
5.1	Normative References.....	8
5.2	Deviations from Test Standards.....	8
6	Glossary of Terms.....	9
7	Equipment Under Test.....	10
7.1	EUT Identification.....	10
7.2	System Equipment.....	10
7.3	EUT Mode of Operation.....	11
7.3.1	Transmission.....	11
8	Modifications.....	12
9	EUT Test Setup.....	13
9.1	Block Diagram.....	13
10	General Technical Parameters.....	14
10.1	Normal Conditions.....	14
10.2	Varying Test Conditions.....	14
11	Multi Radio Radiated Emissions.....	15
11.1	Definitions.....	15
11.2	Test Parameters.....	15
11.3	Test Limit.....	16
11.4	Test Method.....	17
11.5	Test Equipment.....	18
11.6	Test Results.....	19
12	AC power-line conducted emissions.....	27
12.1	Definition.....	27
12.2	Test Parameters.....	27
12.3	Test Limit.....	27
12.4	Test Method.....	28
12.5	Test Equipment.....	28
12.6	Test Results.....	29
13	Measurement Uncertainty.....	31

## 4 Introduction

This report TRA-029714-47-01A presents the Multi Radio Radiated Emissions on a Pace plc, DOCSIS 3 HYBRID GATEWAY STB to specification 47CFR15 Radio Frequency Devices

The testing was carried out for Pace plc by Element, at the address(es) detailed below.

- |  |   |
|--|---|
| <input type="checkbox"/> Element Hull<br>Unit E<br>South Orbital Trading Park<br>Hedon Road<br>Hull<br>HU9 1NJ<br>UK | <input checked="" type="checkbox"/> Element Skelmersdale<br>Unit 1<br>Pendle Place<br>Skemersdale<br>West Lancashire<br>WN8 9PN<br>UK |
|--|---|

This report details the configuration of the equipment, the test methods used and any relevant modifications where appropriate.

All test and measurement equipment under the control of the laboratory and requiring calibration is subject to an established programme and procedures to control and maintain measurement standards. The quality management system meets the principles of ISO 9001, and has quality control procedures for monitoring the validity of tests undertaken. Records and sufficient detail are retained to establish an audit trail of calibration records relating to its test results for a defined period. Under control of the established calibration programme, key quantities or values of the test & measurement instrumentation are within specification and comply with the relevant traceable internationally recognised and appropriate standard specifications, which are UKAS calibrated as such where these properties have a significant effect on results. Participation in inter-laboratory comparisons and proficiency testing ensures satisfactory correlation of results conform to Elements own procedures, as well as statistical techniques for analysis of test data providing the appropriate confidence in measurements.

Throughout this report EUT denotes equipment under test.

FCC Site Listing:

Element is accredited for the above sites under the US-EU MRA, Designation number UK0009.

The test site requirements of ANSI C63.4-2014 are met up to 1GHz.

The test site SVSWR requirements of CISPR 16-1-4:2010 are met over the frequency range 1 GHz to 18 GHz.

## 5 Test Specifications

### 5.1 Normative References

- FCC 47 CFR Ch. I – Part 15 – Radio Frequency Devices.
- ANSI C63.10-2013 – American National Standard of Procedures for Compliance Testing of Unlicensed Wireless Devices.
- ANSI C63.4-2014 – American National Standard for Methods of Measurement of Radio-Noise Emissions from Low-Voltage Electrical and Electronic Equipment in the Range of 9 kHz to 40 GHz.
- Industry Canada RSS-210, Issue 8, December 2010 – Licence-exempt Radio Apparatus (All Frequency Bands): Category I Equipment.
- Industry Canada RSS-Gen, Issue 4, November 2014 – General Requirements for Compliance of Radio Apparatus

### 5.2 Deviations from Test Standards

There were no deviations from the test standard.



## 6 Glossary of Terms

<b>§</b>	denotes a section reference from the standard, not this document
<b>AC</b>	Alternating Current
<b>ANSI</b>	American National Standards Institute
<b>BW</b>	bandwidth
<b>C</b>	Celsius
<b>CFR</b>	Code of Federal Regulations
<b>CW</b>	Continuous Wave
<b>dB</b>	decibel
<b>dBm</b>	dB relative to 1 milliwatt
<b>DC</b>	Direct Current
<b>DSSS</b>	Direct Sequence Spread Spectrum
<b>EIRP</b>	Equivalent Isotropically Radiated Power
<b>ERP</b>	Effective Radiated Power
<b>EUT</b>	Equipment Under Test
<b>FCC</b>	Federal Communications Commission
<b>FHSS</b>	Frequency Hopping Spread Spectrum
<b>Hz</b>	hertz
<b>IC</b>	Industry Canada
<b>ITU</b>	International Telecommunication Union
<b>LBT</b>	Listen Before Talk
<b>m</b>	metre
<b>max</b>	maximum
<b>MIMO</b>	Multiple Input and Multiple Output
<b>min</b>	minimum
<b>MRA</b>	Mutual Recognition Agreement
<b>N/A</b>	Not Applicable
<b>PCB</b>	Printed Circuit Board
<b>PDF</b>	Portable Document Format
<b>Pt-mpt</b>	Point-to-multipoint
<b>Pt-pt</b>	Point-to-point
<b>RF</b>	Radio Frequency
<b>RH</b>	Relative Humidity
<b>RMS</b>	Root Mean Square
<b>Rx</b>	receiver
<b>s</b>	second
<b>SVSWR</b>	Site Voltage Standing Wave Ratio
<b>Tx</b>	transmitter
<b>UKAS</b>	United Kingdom Accreditation Service
<b>V</b>	volt
<b>W</b>	watt
<b>Ω</b>	ohm

## 7 Equipment Under Test

### 7.1 EUT Identification

- Name: DOCSIS 3 HYBRID GATEWAY STB
- Serial Number: FN34A152840077
- Model Number: ND7506
- Build Revision
  - 260-2251000 Layer 3 TV DDR3 Main Board Assembly
  - 262-2227000 Layer 3 TV Server Front Panel assembly
  - 260-2264000 PCA 2.4G WIFI MODULE
  - 260-E397020 PCA 5G WIFI
- Software Version
  - Video Soc
  - BootLoader: CBL v1.74
  - Firmware version: v1.161
  - Bluetooth Driver version: BCM20705B0\_002.001.014.0590.0927
  - CableModem
  - CMBootloader : v1.144
  - CM App: v1.144-Itw

### 7.2 System Equipment

Equipment listed below forms part of the overall test setup and is required for equipment functionality and/or monitoring during testing. The compliance levels achieved in this report relate only to the EUT and not items given in the following list.

- Name: HDMI HDCP Ready Unit
- Sample Number: S03
- Serial Number: DP2012110417
- Model Number: None
- Name: Arris Cadant C3 CMTS
- Sample Number: S04
- Serial Number: 65000181-002109
- Model Number: None
- Name: PX031ECB Box
- Sample Number: S05
- Serial Number: PADA00015189
- Model Number: None
- Name: Dell Latitude Laptop
- Sample Number: S06
- Serial Number: SAL-17646
- Model Number: D430
- Name: Dell Latitude Laptop
- Sample Number: S07
- Serial Number: PACE0000019241
- Model Number: E6400
- Name: AOC 4K Television
- Sample Number: TRA-024769S07
- Serial Number: HCXE8JA002064
- Model Number: None

### 7.3 EUT Mode of Operation

#### 7.3.1 Transmission

The EUT was under the control of test software named 'digi debug' which when run exercised the EUT in its worst case configuration. While the test was running the EUT was decoding AV (audio visual) data from a MOCA (Multimedia over Coax Alliance) stream and then displaying it via HDMI at 2160p resolution. The EUT was connected to a DOCSIS head end. The HDD of the EUT was also active, with data being written to it and then read back. An internal SD card was inserted in order that the SD card TX and RX clock lines (50MHz) were active. A source playing HD AV was connected to the HDMI input of the EUT. Both USB ports were connected to USB 3.0 memory sticks. All other ports were terminated appropriately.

Wifi transmitter control was via commands sent through a terminal program (Tera Term in this case).

Bluetooth control was either 'digi debug' or Blue tool software provided by the manufacturer of the Bluetooth hardware. The commands provided by the manufacturer setup the device into a permanent modulated transmit mode on the required channel.

Channels and modulation types were selected to use combinations with the highest output power levels.

Multi radio Intermodulation Emission - Frequency Set 1			
Radio	Frequency / Channel	Software / Power Setting	Modulation
Bluetooth	2402 MHz / 1	10 (dBm)	8PSK
2.4GHz Wifi	2437 MHz / 6	107	802.11n HT20
5 GHz Wifi	5200 MHz / 40	84	802.11ac VHT 20
Multi radio Intermodulation Emission - Frequency Set 2			
Radio	Frequency / Channel	Software Power Setting	Modulation
Bluetooth	2480 MHz / 79	10 (dBm)	8PSK
2.4GHz Wifi	2437 MHz / 6	107	802.11n HT20
5 GHz Wifi	5200 MHz / 40	84	802.11ac VHT 20
Multi radio Intermodulation Emission - Frequency Set 3			
Radio	Frequency / Channel	Software Power Setting	Modulation
Bluetooth	2402 MHz / 1	10 (dBm)	8PSK
2.4GHz Wifi	2437 MHz / 6	107	802.11n HT20
5 GHz Wifi	5795 MHz / 159	82	802.11ac VHT 40
Multi radio Intermodulation Emission - Frequency Set 4			
Radio	Frequency / Channel	Software Power Setting	Modulation
Bluetooth	2480 MHz / 79	10 (dBm)	8PSK
2.4GHz Wifi	2437 MHz / 6	107	802.11n HT20
5 GHz Wifi	5795 MHz / 159	82	802.11ac VHT 40

## **8 Modifications**

No modifications were performed during this assessment.

## 9 EUT Test Setup

### 9.1 Block Diagram

The following diagram shows basic EUT interconnections with cable type and cable lengths identified:

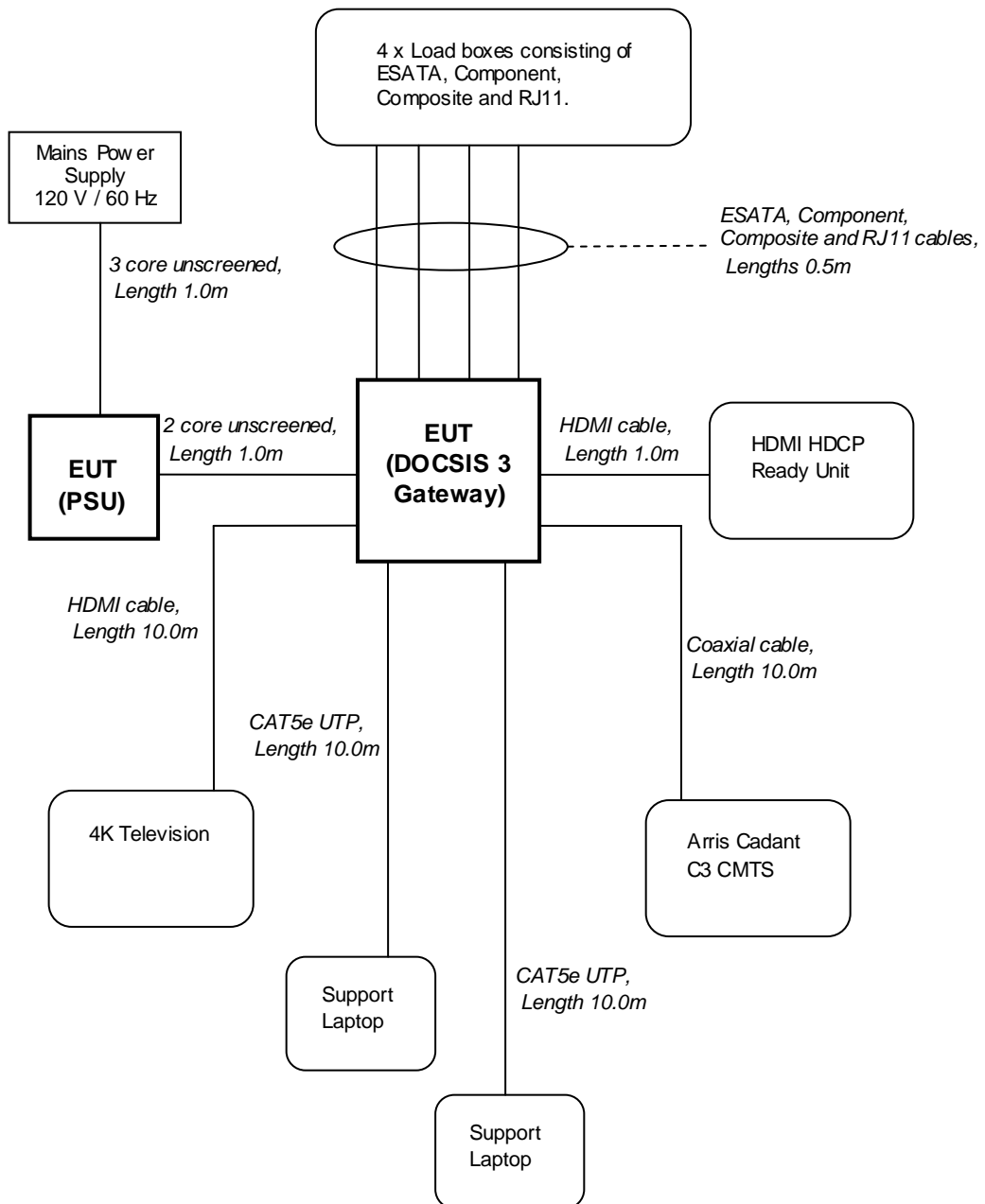

## 10 General Technical Parameters

### 10.1 Normal Conditions

The E U T was tested under the normal environmental conditions of the test laboratory, except where otherwise stated. The normal power source applied was approx. 5 V dc from the adaptor / 110 V ac, 60 Hz, from the mains.

### 10.2 Varying Test Conditions

There are no specific frequency stability requirements for the type of device. The results contained in this report demonstrate that the occupied bandwidth is contained within the authorised band and the manufacturer has declared sufficient frequency stability (refer to section 7.4).

Variation of supply voltage is required to ensure stability of the declared output power. During carrier power testing the following variations were made:

	<b>Category</b>	<b>Nominal</b>	<b>Variation</b>
<input checked="" type="checkbox"/>	Mains	110 V ac +/-2 %	85 % and 115 %
<input type="checkbox"/>	Battery	New battery	N/A

## 11 Multi Radio Radiated Emissions

### 11.1 Definitions

#### *Spurious emissions*

Emissions on a frequency or frequencies, which are outside the necessary bandwidth and the level of which may be reduced without affecting the corresponding transmission of information. Spurious emissions include harmonic emissions, parasitic emissions, intermodulation products and frequency conversion products, but exclude out-of-band emissions.

#### *Restricted bands*

A frequency band in which intentional radiators are permitted to radiate only spurious emissions but not fundamental signals.

### 11.2 Test Parameters

Test Location:	Element Skelmersdale
Test Chamber:	Radio Chamber (REF940)
Test Standard and Clause:	ANSI C63.10-2013, Clause 6.5 and 6.6
EUT Channels / Frequencies Measured:	See Section 7
Deviations From Standard:	None
Measurement BW:	30 MHz to 1 GHz: 120 kHz Above 1 GHz: 1 MHz
Measurement Detector:	Up to 1 GHz: quasi-peak Above 1 GHz: RMS average and Peak

#### **Environmental Conditions (Normal Environment)**

Temperature: 24 °C	+15 °C to +35 °C (as declared)
Humidity: 32 % RH	20 % RH to 75 % RH (as declared)
Supply: 110V ac	230 V ac $\pm$ 10 % (as declared)

### 11.3 Test Limit

Unwanted emissions below 1 GHz must comply with the general field strength limits set forth in 15.209. Further, any U-NII devices using an AC power line are required to comply also with the conducted limits set forth in § 15.207.

Except as shown above, the peak emissions outside of the frequency bands of operation shall be attenuated in accordance with the following limits:

For transmitters operating in the 5.15–5.25 GHz band: all emissions outside of the 5.15–5.35 GHz band shall not exceed an EIRP of –27 dBm/MHz.

For transmitters operating in the 5.725–5.825 GHz band: all emissions within the frequency range from the band edge to 10 MHz above or below the band edge shall not exceed an EIRP of –17 dBm/MHz; for frequencies 10 MHz or greater above or below the band edge, emissions shall not exceed an EIRP of –27 dBm/MHz.

The provisions of 15.205 apply to intentional radiators operating under this section.

Where regulatory limits are defined as EIRP in dBm/MHz limits are converted to field strength values as per ANSI C63.10

Operating Band (GHz)	EIRP Limit (dBm / MHz)	Field Strength Limit (dB $\mu$ v/m @ 3m)
5.15–5.25 GHz	–27 dBm/MHz	68.2 dB $\mu$ v/m @ 3m
5.725–5.825 GHz	–17 dBm/MHz	78.2 dB $\mu$ v/m @ 3m
	–27 dBm/MHz	68.2 dB $\mu$ v/m @ 3m

Unwanted emissions that fall within the restricted frequency bands shall comply with the limits specified of 15.205 below:

#### General Field Strength Limits for License-Exempt Transmitters at Frequencies above 30 MHz

Frequency (MHz)	Field Strength ( $\mu$ V/m at 3 m)
30 to 88	100
88 to 216	150
216 to 960	200
Above 960	500



## 11.4 Test Method

With the EUT setup as per section 9 of this report and connected as per Figure i, the emissions from the EUT were measured on a spectrum analyzer / EMI receiver.

Radiated electromagnetic emissions from the EUT are checked first by preview scans. Preview scans for all spectrum and modulation characteristics are checked, using a peak detector and where applicable worst-case determined for function, operation, orientation, etc. for both vertical and horizontal polarisations. Pre-scan plots are shown with a peak detector and 100 kHz RBW.

If the EUT connects to auxiliary equipment and is table or floor standing, the configurations prescribed in ANSI C63.10 are followed. Alternatively, a layout closest to normal use (as declared by the provider) is employed, (see EUT setup photographs for more detail).

Emissions between 30 MHz and 1 GHz are measured using calibrated broadband antennas. Emissions above 1 GHz are characterized using standard gain horn antennas. Pre-amplifiers and filters are used where required. Care is taken to ensure that test receiver resolution bandwidth, video bandwidth and detector type(s) meet the regulatory requirements.

For both horizontal and vertical polarizations, the EUT is then rotated through 360 degrees in azimuth until the highest emission is detected. At the previously determined azimuth the test antenna is raised and lowered from 1 to 4 m in height until a maximum emission level is detected, this maximum value is recorded.

Power values measured on the test receiver / analyzer are converted to field strength, FS, in dB $\mu$ V/m at the regulatory distance, using:

$$FS = PR + CL + AF - PA + DC - CF$$

Where,

PR is the power recorded on the receiver / spectrum analyzer in dB $\mu$ V;

CL is the cable loss in dB;

AF is the test antenna factor in dB/m;

PA is the pre-amplifier gain in dB (where used);

DC is the duty correction factor in dB (where used, e.g. harmonics of pulsed fundamental);

CF is the distance factor in dB (where measurement distance different to limit distance);

This field strength value is then compared with the regulatory limit.

**Figure i Test Setup**

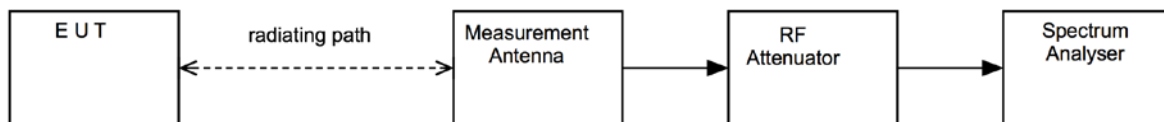

### 11.5 Test Equipment

<i>Type of Equipment</i>	<i>Maker/Supplier</i>	<i>Model Number</i>	<i>Element Number</i>	<i>Calibration Due Date</i>
Bilog	Chase	CBL611/A	UH191	26/02/2017
ESVS10	R&S	ESVS10	L352	07/08/2016
Spectrum Analyser	R&S	FSU26	REF909	13/02/2016
Spectrum Analyser	R&S	FSU40	U281	24/04/2016
Horn Antenna	EMCO	3115	L139	20/09/2015
Pre-Amplifier	Agilent	8449B	L572	10/02/2016
Horn Antenna	Flann	20240-20	L300	10/02/2016
Horn Antenna	Flann	22240-20	L301	Note 1
Filter	BSC	SN 4478	U543	23/08/2017
BandStop Filter 5.15 - 5.35 GHz)	BSC	SN4832	REF841	In Use
BandStop Filter (5.725 - 5.875 GHz)	BSC	SN 4834	REF843	In Use

#### ANSI C63.10 - 4.4.3 a) Antenna calibration

Standard gain horns need not be periodically recalibrated, unless damage or deterioration is suspected or known to have occurred. If a standard gain horn is not periodically recalibrated, then its critical dimensions (see IEEE Std 1309-2005) shall be verified and documented on an annual basis

### 11.6 Test Results

Multi radio Intermodulation Emission Frequency Set 1										
Detector	Freq. (MHz)	Meas'd Emission (dBμV)	Cable Loss (dB)	Antenna Factor (dB/m)	Pre-amp Gain (dB)	Duty Cycle Corr'n (dB)	Distance Extrap'n Factor (dB)	Field Strength (dBμV/m)	Field Strength (μV/m)	Limit (μV/m)
No Multi Radio Intermodulation Emissions Detected										

### Multi radio Intermodulation Emission - Frequency Set 1

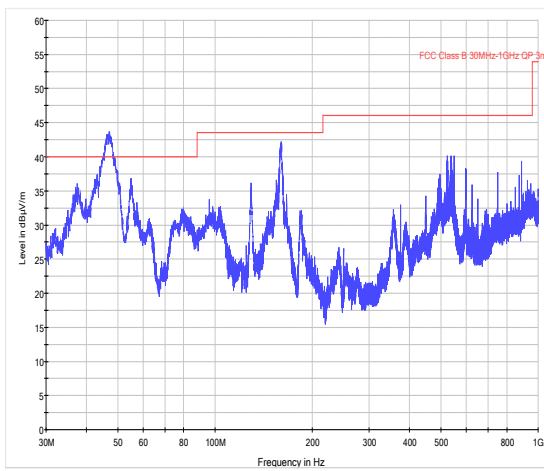

30 MHz – 1 GHz

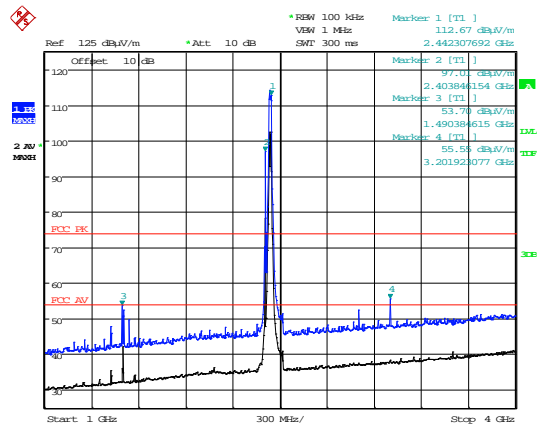

1 GHz – 4 GHz

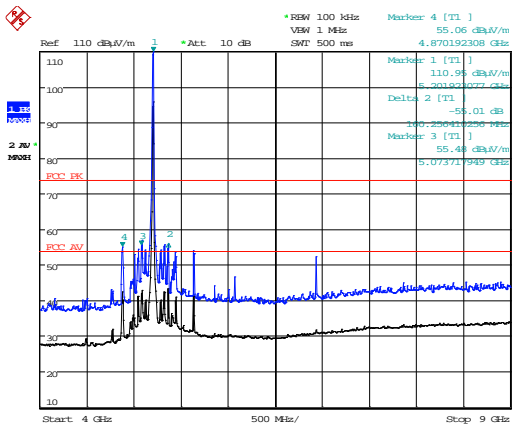

4 GHz – 9 GHz

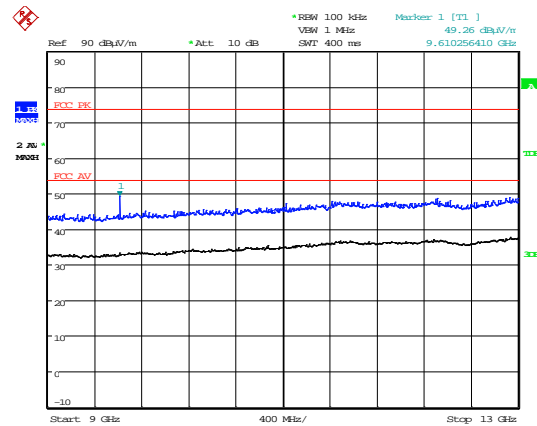

9 GHz – 13 GHz

Date: 12.NOV.2015 10:17:59

Date: 12.NOV.2015 10:47:16

### Multi radio Intermodulation Emission - Frequency Set 1

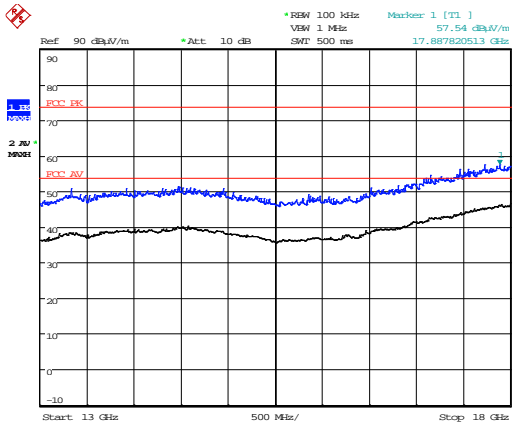

Date: 12.NOV.2015 11:02:23

13 GHz – 18 GHz

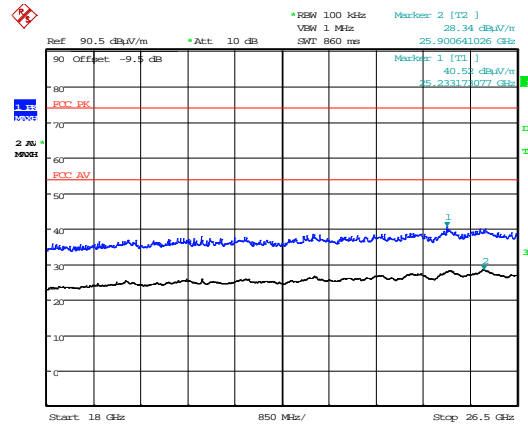

Date: 11.NOV.2015 10:41:59

18 GHz – 26.5 GHz

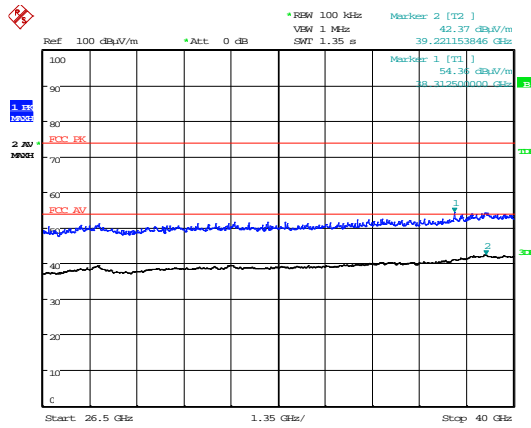

Date: 11.NOV.2015 10:00:54

26.5 GHz – 40 GHz

Multi radio Intermodulation Emission Frequency Set 2										
Detector	Freq. (MHz)	Meas'd Emission (dB $\mu$ V)	Cable Loss (dB)	Antenna Factor (dB/m)	Pre-amp Gain (dB)	Duty Cycle Corr'n (dB)	Distance Extrap'n Factor (dB)	Field Strength (dB $\mu$ V/m)	Field Strength ( $\mu$ V/m)	Limit ( $\mu$ V/m)
No Multi Radio Intermodulation Emissions Detected										

### Multi radio Intermodulation Emission - Frequency Set 2

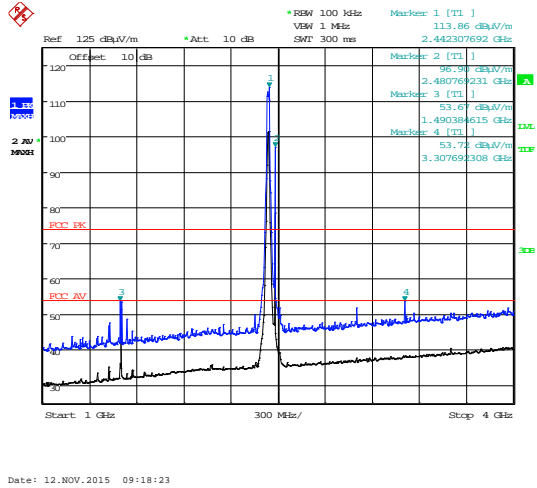

30 MHz – 1 GHz

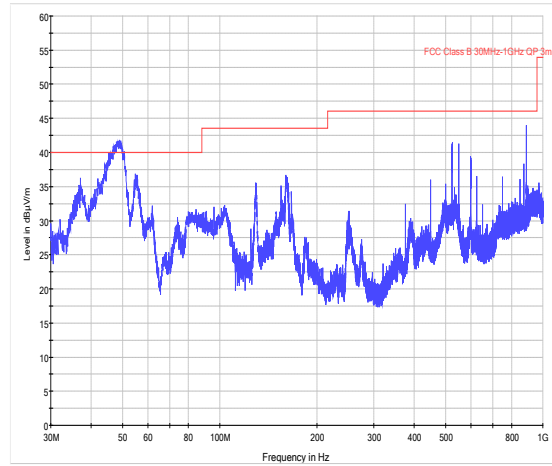

1 GHz – 4 GHz

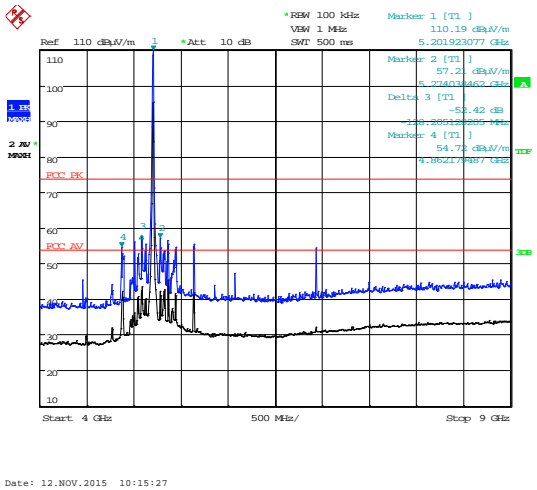

4 GHz – 9 GHz

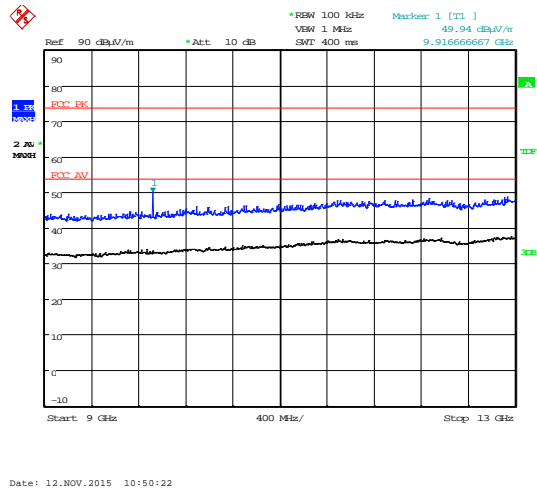

9 GHz – 13 GHz

### Multi radio Intermodulation Emission - Frequency Set 2

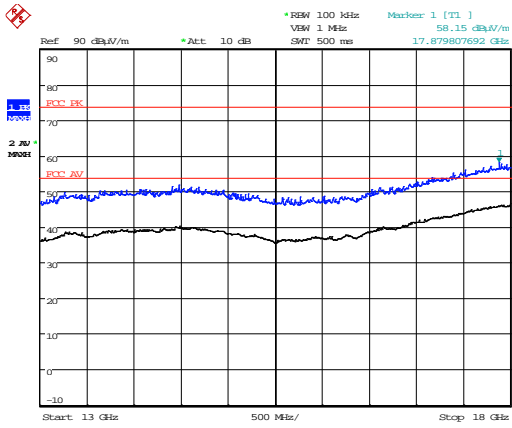

Date: 12.NOV.2015 10:58:03

13 GHz – 18 GHz

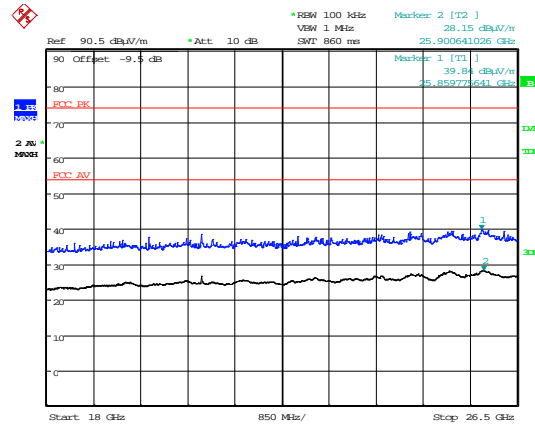

Date: 11.NOV.2015 10:43:16

18 GHz – 26.5 GHz

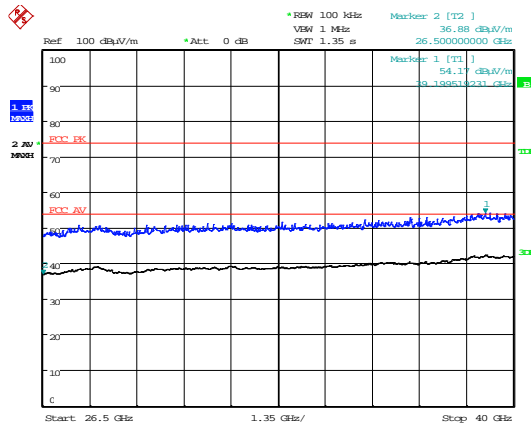

Date: 11.NOV.2015 09:56:26

26.5 GHz – 40 GHz

Multi radio Intermodulation Emission Frequency Set 3										
Detector	Freq. (MHz)	Meas'd Emission (dBμV)	Cable Loss (dB)	Antenna Factor (dB/m)	Pre-amp Gain (dB)	Duty Cycle Corr'n (dB)	Distance Extrap'n Factor (dB)	Field Strength (dBμV/m)	Field Strength (μV/m)	Limit (μV/m)
No Multi Radio Intermodulation Emissions Detected										

### Multi radio Intermodulation Emission - Frequency Set 3

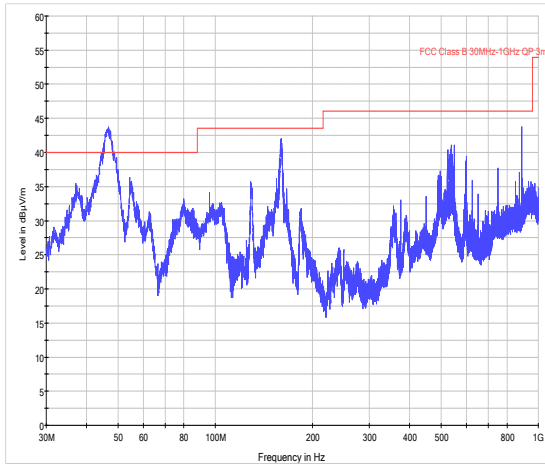

30 MHz – 1 GHz

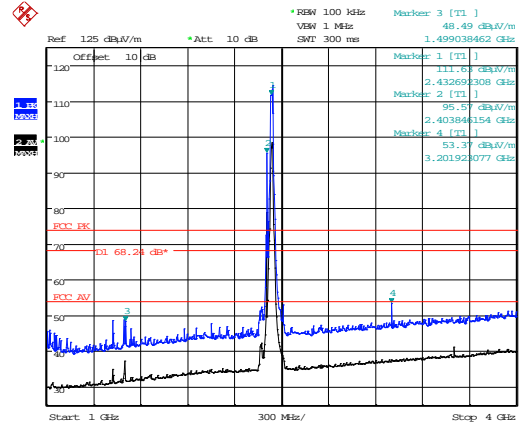

1 GHz – 4 GHz

Date: 30.MAR.2016 17:37:55

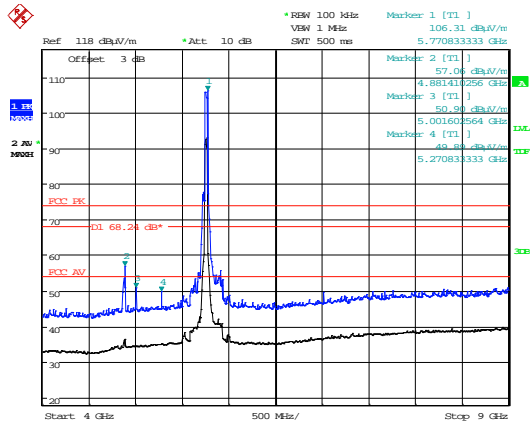

4 GHz – 9 GHz

Date: 31.MAR.2016 10:45:30

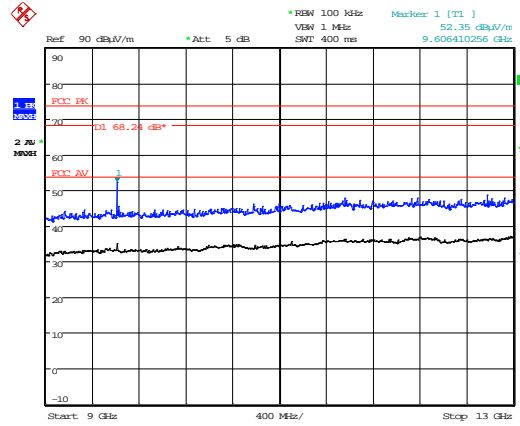

9 GHz – 13 GHz

Date: 31.MAR.2016 10:26:39

### Multi radio Intermodulation Emission - Frequency Set 3

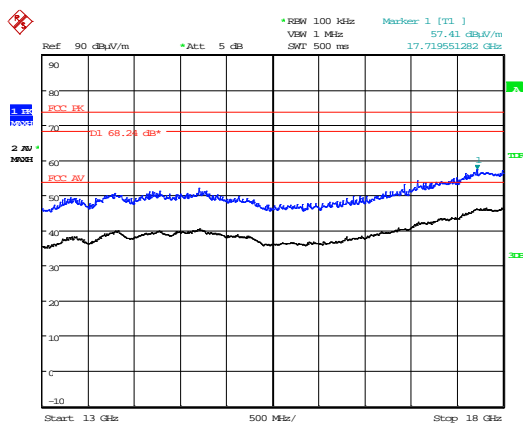

Date: 31.MAR.2016 10:21:56

13 GHz – 18 GHz

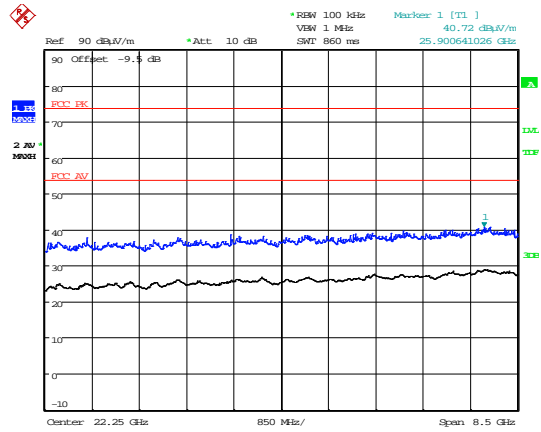

Date: 31.MAR.2016 11:17:45

18 GHz – 26.5 GHz

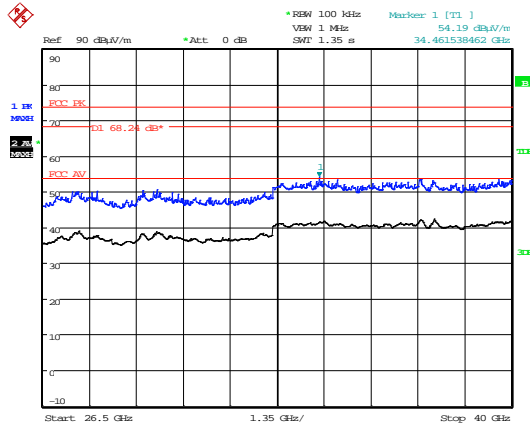

Date: 31.MAR.2016 11:01:27

26.5 GHz – 40 GHz



Multi radio Intermodulation Emission Frequency Set 4										
Detector	Freq. (MHz)	Meas'd Emission (dB $\mu$ V)	Cable Loss (dB)	Antenna Factor (dB/m)	Pre-amp Gain (dB)	Duty Cycle Corr'n (dB)	Distance Extrap'n Factor (dB)	Field Strength (dB $\mu$ V/m)	Field Strength ( $\mu$ V/m)	Limit ( $\mu$ V/m)
No Multi Radio Intermodulation Emissions Detected										

### Multi radio Intermodulation Emission - Frequency Set 4

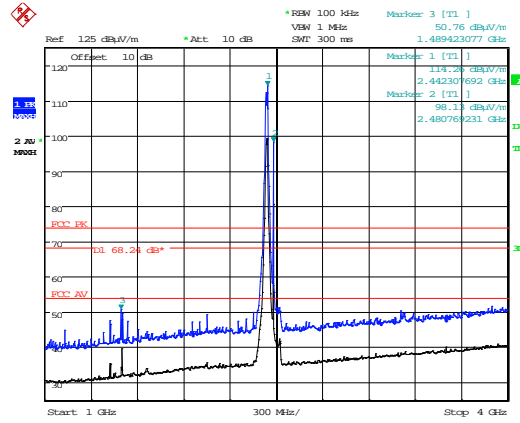
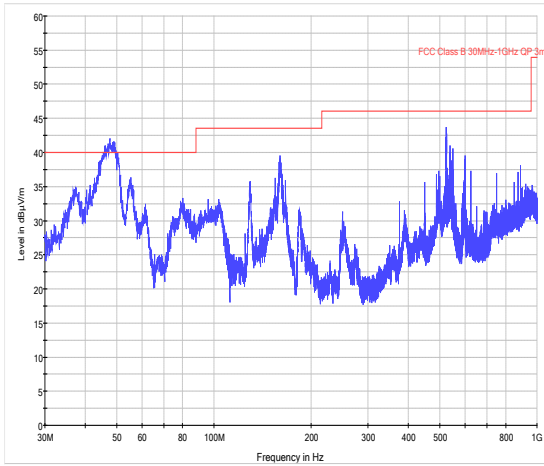

Date: 31.MAR.2016 09:41:49

### 30 MHz – 1 GHz

### 1 GHz – 4 GHz

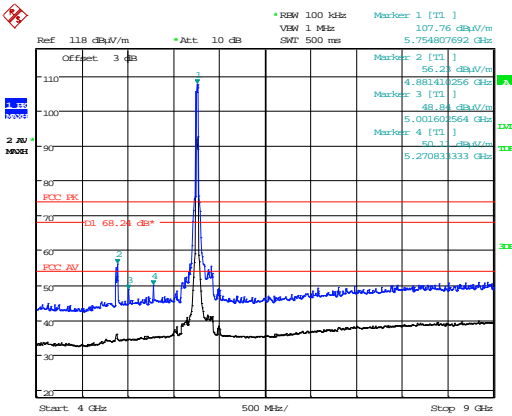

Date: 31.MAR.2016 10:40:56

### 4 GHz – 9 GHz

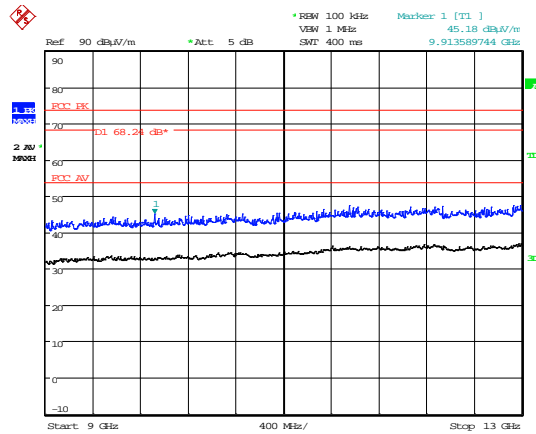

Date: 31.MAR.2016 10:32:33

### 9 GHz – 13 GHz

### Multi radio Intermodulation Emission - Frequency Set 4

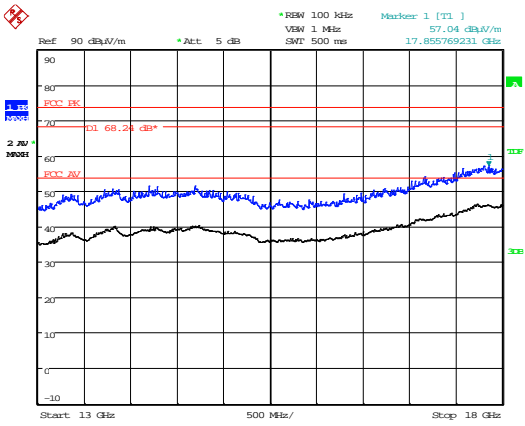

Date: 31.MAR.2016 10:20:11

13 GHz – 18 GHz

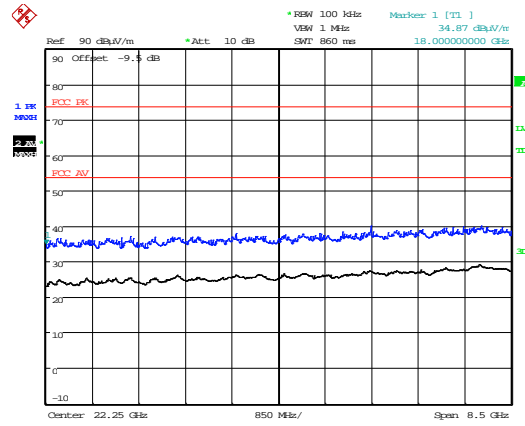

Date: 31.MAR.2016 11:13:26

18 GHz – 26.5 GHz

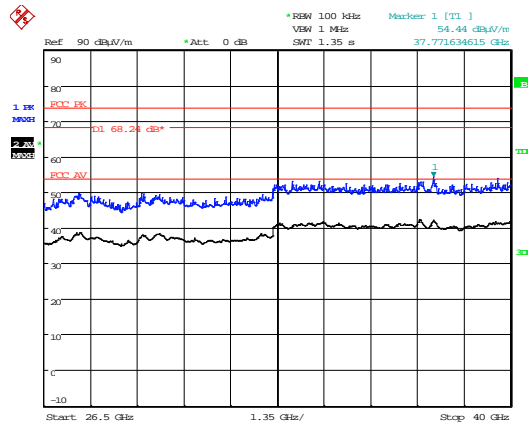

Date: 31.MAR.2016 11:07:18

26.5 GHz – 40 GHz

## 12 AC power-line conducted emissions

### 12.1 Definition

Line-to-ground radio-noise voltage that is conducted from all of the EUT current-carrying power input terminals that are directly (or indirectly via separate transformers or power supplies) connected to a public power network.

### 12.2 Test Parameters

Test Location:	Element Skelmersdale
Test Chamber:	Radio Chamber (REF940)
Test Standard and Clause:	ANSI C63.10-2013, Clause 6.2
EUT Channels / Frequencies Measured:	Mid
EUT Channel Bandwidths:	Bluetooth, 3MHz : 802.11n, 20 MHz : 802.1ac, 20 MHz
EUT Modulation:	8 PSK, 802.11n HT20, 802.11 ac VHT20
Deviations From Standard:	None
Measurement BW:	9 kHz
Measurement Detectors:	Quasi-Peak and Average, RMS

### Environmental Conditions (Normal Environment)

Temperature: 19 °C	+15 °C to +35 °C (as declared)
Humidity: 39 % RH	20 % RH to 75 % RH (as declared)
Supply: 110 V ac	1100 V ac ±10 % (as declared)

### 12.3 Test Limit

A radio apparatus that is designed to be connected to the public utility (AC) power line shall ensure that the radio frequency voltage, which is conducted back onto the AC power line on any frequency or frequencies within the band 150 kHz to 30 MHz, shall not exceed the limits in Table 3.

**Table 3 – AC Power Line Conducted Emission Limits**

Frequency (MHz)	Conducted limit (dBµV)	
	Quasi-Peak	Average**
0.15 to 0.5	66 to 56	56 to 46
0.5 to 5	56	46
5 to 30	60	50

\*The level decreases linearly with the logarithm of the frequency.

\*\*A linear average detector is required.

## 12.4 Test Method

With the EUT setup in a screened room, as per section 9 of this report and connected as per Figure ii, the power line emissions were measured on a spectrum analyzer / EMI receiver.

AC power line conducted emissions from the EUT are checked first by preview scans with peak and average detectors covering both live and neutral lines. A spectrum analyzer is used to determine if any periodic emissions are present.

Formal measurements using the correct detector(s) and bandwidth are made on frequencies identified from the preview scans. Final measurements were performed with EUT set at its maximum duty in transmit and receive modes.

**Figure ii Test Setup**

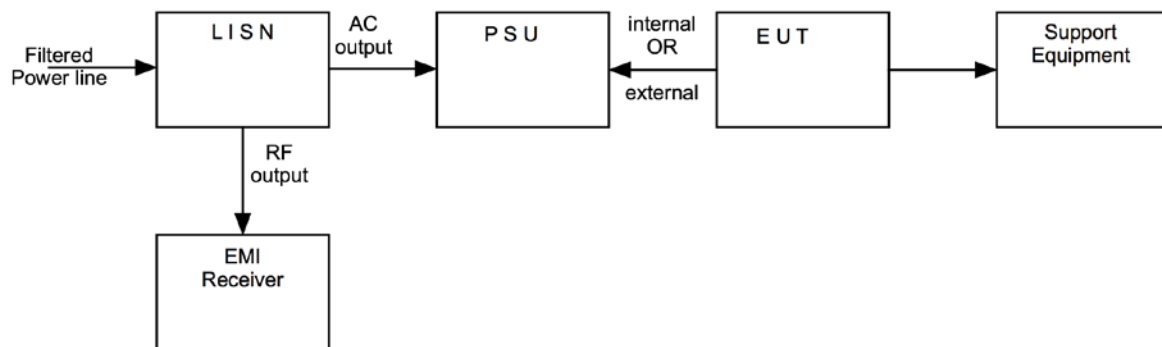

## 12.5 Test Equipment

<i>Type of Equipment</i>	<i>Maker/Supplier</i>	<i>Model Number</i>	<i>Element Number</i>	<i>Calibration Due Date</i>
LISN	R&S	ESH3-Z5.831.5	U195	04/06/2016
EMI Receiver	R&S	ESHS10	U003	25/06/2016

### 12.6 Test Results

Full Spectrum

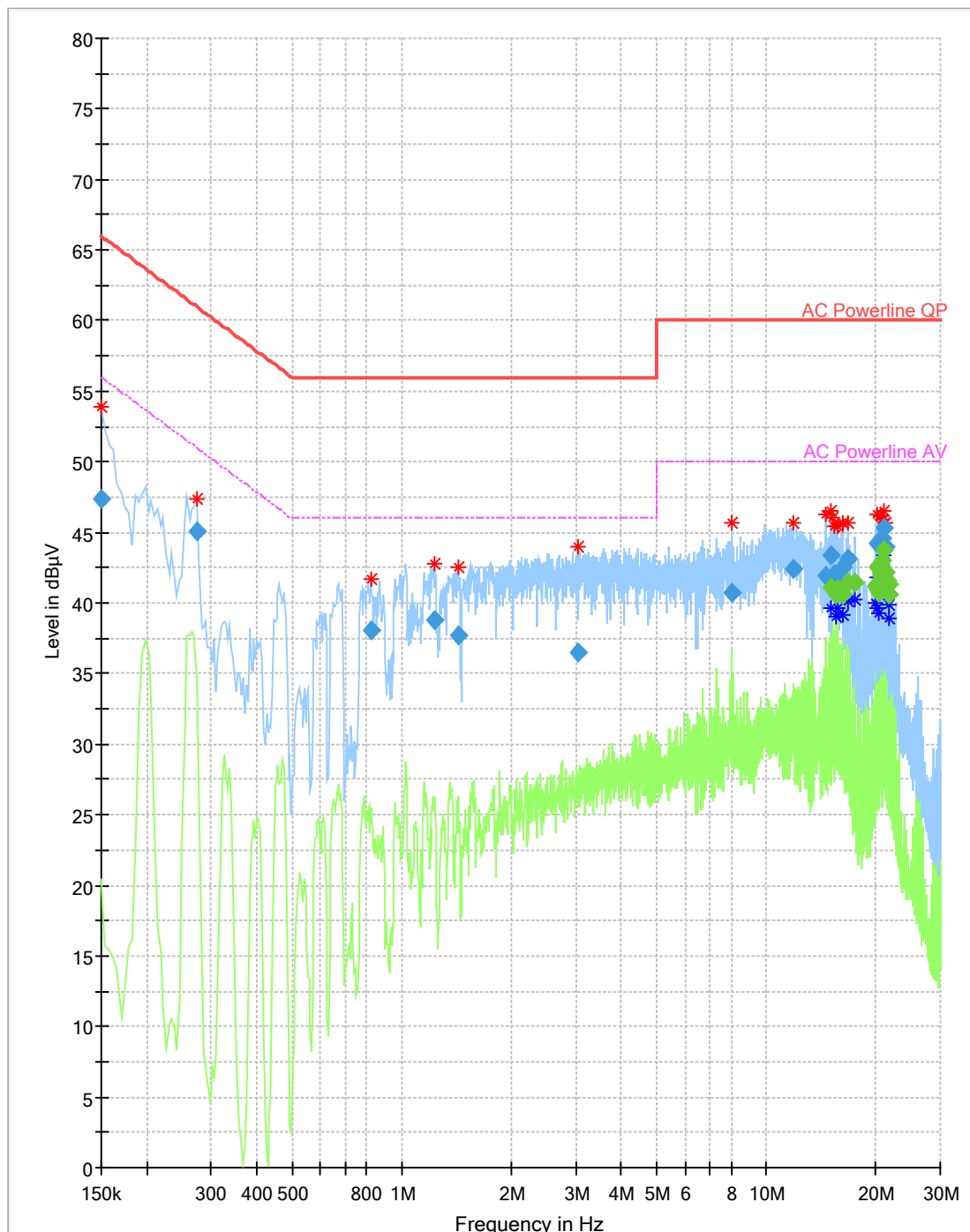

## Final\_Result

Frequency (MHz)	QuasiPeak (dBμV)	Average (dBμV)	Limit (dBμV)	Margin (dB)	Meas. Time (ms)	Bandwidth (kHz)	Line	PE	Corr. (dB)
0.150000	47.38	---	66.00	18.62	2000.0	10.000	N	GND	0.1
0.274000	45.09	---	61.00	15.90	2000.0	10.000	L1	GND	0.1
0.822000	38.06	---	56.00	17.94	2000.0	10.000	N	GND	0.2
1.226000	38.84	---	56.00	17.16	2000.0	10.000	N	GND	0.2
1.430000	37.71	---	56.00	18.29	2000.0	10.000	N	GND	0.2
3.054000	36.46	---	56.00	19.54	2000.0	10.000	L1	GND	0.3
8.034000	40.77	---	60.00	19.23	2000.0	10.000	L1	GND	0.6
11.798000	42.44	---	60.00	17.56	2000.0	10.000	L1	GND	0.8
14.610000	41.93	---	60.00	18.07	2000.0	10.000	L1	GND	1.0
15.026000	43.38	---	60.00	16.62	2000.0	10.000	L1	GND	1.0
15.026000	---	41.04	50.00	8.96	2000.0	10.000	L1	GND	1.0
15.230000	41.87	---	60.00	18.13	2000.0	10.000	L1	GND	1.0
15.338000	42.08	---	60.00	17.92	2000.0	10.000	L1	GND	1.0
15.546000	---	40.63	50.00	9.37	2000.0	10.000	N	GND	1.1
15.754000	---	41.01	50.00	8.99	2000.0	10.000	L1	GND	1.1
15.758000	41.62	---	60.00	18.38	2000.0	10.000	L1	GND	1.1
16.170000	---	40.59	50.00	9.41	2000.0	10.000	L1	GND	1.1
16.174000	42.50	---	60.00	17.50	2000.0	10.000	L1	GND	1.1
16.798000	43.12	---	60.00	16.88	2000.0	10.000	L1	GND	1.1
16.798000	---	41.50	50.00	8.50	2000.0	10.000	L1	GND	1.1
17.426000	---	41.41	50.00	8.59	2000.0	10.000	L1	GND	1.2
19.930000	---	41.18	50.00	8.82	2000.0	10.000	L1	GND	1.3
20.034000	44.29	---	60.00	15.71	2000.0	10.000	L1	GND	1.3
20.034000	---	42.54	50.00	7.46	2000.0	10.000	L1	GND	1.3
20.138000	---	40.96	50.00	9.04	2000.0	10.000	N	GND	1.3
20.350000	---	40.75	50.00	9.25	2000.0	10.000	L1	GND	1.4
20.454000	44.49	---	60.00	15.51	2000.0	10.000	N	GND	1.4
20.454000	---	42.62	50.00	7.38	2000.0	10.000	N	GND	1.4
20.558000	---	42.23	50.00	7.77	2000.0	10.000	N	GND	1.4
20.662000	---	41.98	50.00	8.02	2000.0	10.000	N	GND	1.4
20.870000	44.57	---	60.00	15.43	2000.0	10.000	N	GND	1.4
20.870000	---	43.07	50.00	6.93	2000.0	10.000	N	GND	1.4
20.974000	45.26	---	60.00	14.74	2000.0	10.000	N	GND	1.4
20.974000	---	43.74	50.00	6.26	2000.0	10.000	N	GND	1.4
21.078000	---	42.27	50.00	7.73	2000.0	10.000	L1	GND	1.4
21.182000	---	42.22	50.00	7.78	2000.0	10.000	L1	GND	1.4
21.182000	43.98	---	60.00	16.02	2000.0	10.000	N	GND	1.4
21.498000	---	41.55	50.00	8.45	2000.0	10.000	L1	GND	1.4
21.602000	---	41.29	50.00	8.71	2000.0	10.000	L1	GND	1.4
21.706000	---	40.61	50.00	9.39	2000.0	10.000	L1	GND	1.4

## 13 Measurement Uncertainty

### Calculated Measurement Uncertainties

All statements of uncertainty are expanded standard uncertainty using a coverage factor of 1.96 to give a 95 % confidence:

#### [1] Radiated spurious emissions

Uncertainty in test result (30 MHz to 1 GHz) = **4.6 dB**

Uncertainty in test result (1 GHz to 18 GHz) = **4.7 dB**

#### [2] AC power line conducted emissions

Uncertainty in test result = **3.4 dB**

#### [3] Occupied bandwidth

Uncertainty in test result = **15.5 %**

#### [4] Conducted carrier power

Uncertainty in test result (Power Meter) = **1.08 dB**

#### [5] Conducted / radiated RF power out-of-band

Uncertainty in test result – up to 8.1 GHz = **3.31 dB**

Uncertainty in test result – 8.1 GHz to 15.3 GHz = **4.43 dB**

Uncertainty in test result (30 MHz to 1 GHz) = **4.6 dB**

Uncertainty in test result (1 GHz to 18 GHz) = **4.7 dB**

#### [6] Power spectral density

Uncertainty in test result (Spectrum Analyser) = **2.48 dB**