



MINDSTORMS[®]

NXT

BUILD AND PROGRAM ROBOTS THAT DO WHAT YOU WANT!

LEGO[®] MINDSTORMS[®]

User Guide

WELCOME TO THE WORLD OF LEGO® MINDSTORMS®

Congratulations on your new LEGO® MINDSTORMS® NXT robotics tool set. You now have the power to build and program robots that do what you want!



Dream it, build it

Your MINDSTORMS NXT set enables you to create thousands of robotic inventions. Intelligent robots that see, hear, speak, feel and move. Advanced robots that you can control with your mobile phone. Cool robots that guard your room and do your chores. If you can dream it, you can build it.



Build. Program. Go!

Creating a MINDSTORMS robot is easy. Build the robot using your LEGO elements. Program it using the easy-to-use software and watch your robot come alive. For your first robotic adventure, try out the quick-build model that you can build and program in less than 30 minutes.

Smart technologies

Your MINDSTORMS NXT set features the latest in robotic technology: an advanced 32-bit programmable microcontroller; icon-based drag and drop programming software and interactive challenges; smart sensors and Interactive Servo Motors; wireless Bluetooth and USB connection. In fact all the smart technologies you need to create your dream robot.

MINDSTORMS.com

You are now a part of the worldwide LEGO MINDSTORMS community. Log on to MINDSTORMS.com and get more robotic challenges. Download programs, sound effects and other cool stuff. Share your inventions and exchange tips and tricks with other MINDSTORMS users. www.MINDSTORMS.com is your new robotic hot spot.



Find out more

In this User Guide you can learn more about the technology and the many exciting features in your MINDSTORMS set.

Have fun building your own amazing robots!

The LEGO MINDSTORMS team.

CONTENTS

INTRODUCTION

Build. Program. Go! 4

NXT TECHNOLOGY

NXT technology overview 6

Connecting the NXT technology 8

About the NXT..... 10

Installing batteries in your NXT..... 12

NXT main menu..... 13

NXT icons..... 20

Touch Sensor 22

Sound Sensor 23

Light Sensor 24

Ultrasonic Sensor..... 25

Interactive Servo Motors..... 26

Using Bluetooth 28

SOFTWARE

System requirements 38

Installing the software..... 38

Your first program 40

Software user interface 42

The Robo Center 44

The programming palette..... 45

The configuration panel 47

The Controller 47

LEGO BRICKS

Element overview..... 48

Building instructions..... 49

Test pad 72

USEFUL INFORMATION

Troubleshooting 74

BUILD. PROGRAM. GO!



Build

Build a robot. You can find building instructions in this User Guide, in the software or at www.MINDSTORMS.com. Or you can use your imagination to build your own unique robot.



Program

Program your robot to do what you want. Use the LEGO® MINDSTORMS® NXT Software to make a program. Download the program to the NXT by using the USB cable or the wireless Bluetooth connection.

INTRODUCTION

Quick Start

Use the Quick Start kit to get your first MINDSTORMS experience. In the Quick Start kit you will find everything you need to get off to a great start. It will only take you a few minutes to create your first MINDSTORMS robot, test it, and get a fun reaction.



Go!

Run the program and watch your robot come to life.

NXT TECHNOLOGY OVERVIEW

The NXT

The NXT is an intelligent, computer-controlled LEGO® brick and the brain of the MINDSTORMS® robot.



Touch Sensor

Enables the robot to feel and react to its environment.



Sound Sensor

Enables the robot to hear and react to sound.



Light Sensor

Enables the robot to detect light and color.

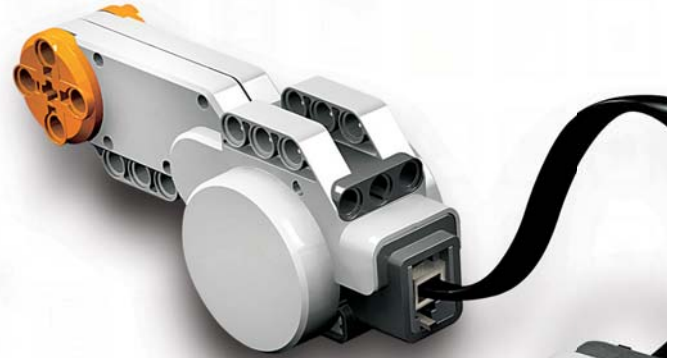

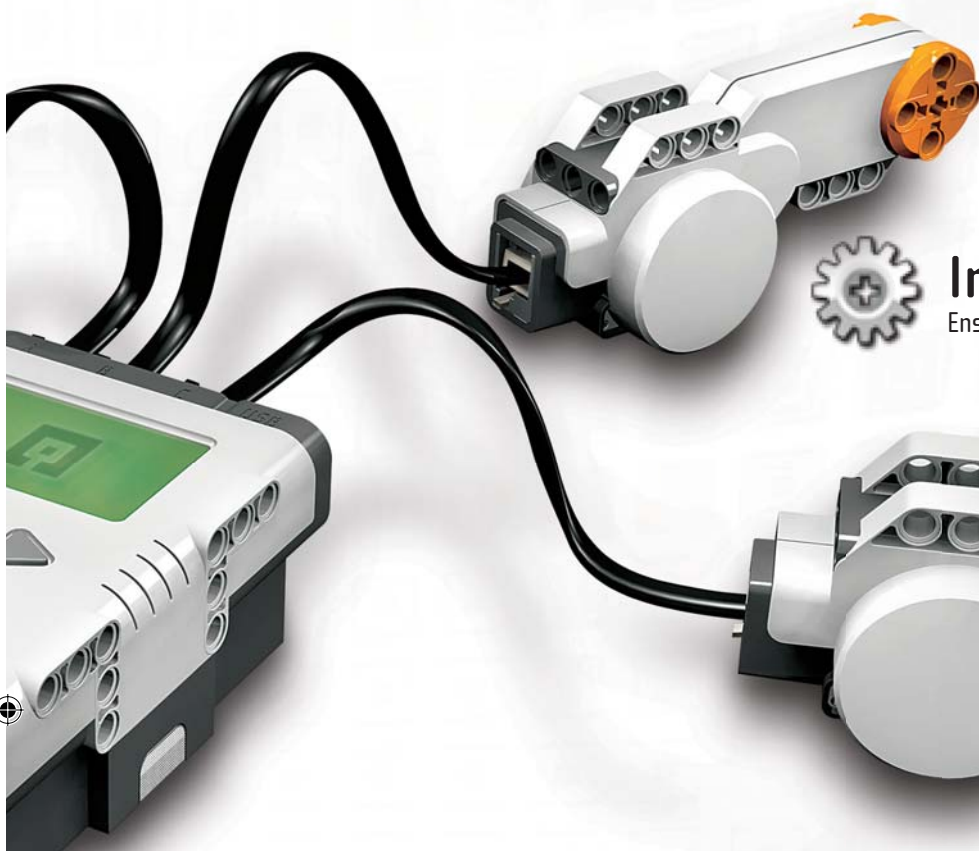

Interactive Servo Motors

Ensure that the robot moves with precision.



Ultrasonic Sensor

Enables the robot to see, measure distance to an object, and react to movement.



Standard port settings for sensors and motors

To make your robot work correctly, the sensors and motors should be connected to specific input and output ports. Here are the standard port settings:

Input ports

- Port 1: Touch Sensor
- Port 2: Sound Sensor
- Port 3: Light Sensor
- Port 4: Ultrasonic Sensor

Output ports

- Port A: Motor used for an extra function
- Port B: Motor for movement
- Port C: Motor for movement

CONNECTING THE NXT TECHNOLOGY



Note that ALL of the black 6-wire cables can be used in both input and output ports, sensors and motors. To work, sensors MUST be attached to the input ports (1-4) and motors MUST be attached to the output ports (A-C).

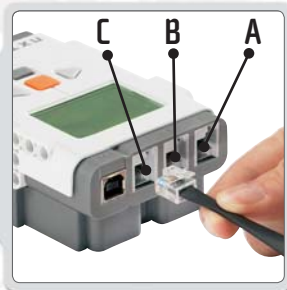

Connecting motors

To connect a motor to the NXT, use one of the black 6-wire cables. Attach one end of the cable to the motor and the other to one of the NXT's output ports (A, B, or C).

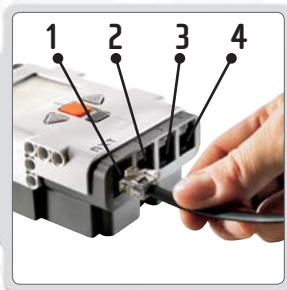

Connecting sensors

To connect a sensor to the NXT, use one of the black 6-wire cables. Attach one end of the cable to the sensor and the other to one of the NXT's input ports (1, 2, 3, or 4).



Downloading and uploading

The USB port and wireless Bluetooth connection let you download and upload data between your computer and the NXT. If your computer has Bluetooth capability, you can download programs to the NXT without using the USB cable. If your computer does not have Bluetooth capability, you must use the USB cable or install a Bluetooth USB dongle on your computer. NOTE: Read more about wireless Bluetooth communication on page 28.

NXT TECHNOLOGY



Connecting the NXT to a PC with a USB cable

Turn on the NXT.



Make sure that the LEGO® MINDSTORMS® NXT Software is installed before connecting your NXT to your PC (see page 38).



Connect the PC and the NXT with the USB cable.

When the PC identifies the NXT it will automatically finalize the installation of the LEGO MINDSTORMS NXT Software.

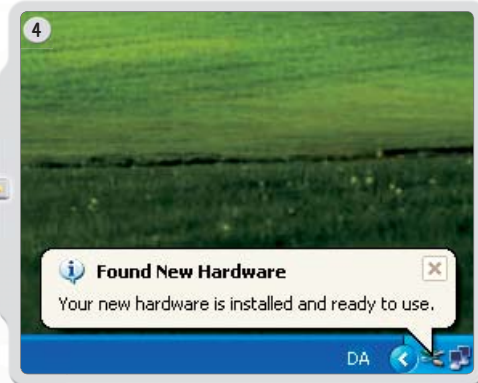

Connecting the NXT to a Macintosh with a USB cable

Make sure that the LEGO MINDSTORMS NXT Software is installed before connecting your NXT to your Macintosh (see page 39).

Turn on your NXT.

Connect the USB cable to the NXT.

Connect the USB cable to the Macintosh and you're ready to go.

NXT TECHNOLOGY

ABOUT THE NXT

The NXT is the brain of a MINDSTORMS® robot. It's an intelligent, computer-controlled LEGO® brick that lets a MINDSTORMS robot come alive and perform different operations.

Please note that all text on the NXT display is in English.

Motors ports

The NXT has three output ports for attaching motors. To make the motor work, the motors need to be attached to port A, B or C

Bluetooth icon

The Bluetooth icon shows the current status of any wireless Bluetooth connections. If there is no Bluetooth icon shown, Bluetooth is OFF.



Bluetooth is ON but your NXT is not visible to other Bluetooth devices.



Bluetooth is ON and your NXT is visible to other Bluetooth devices.



Bluetooth is ON and your NXT is connected to a Bluetooth device.

USB icon

When you connect your NXT to a computer with a USB cable, a USB icon will be displayed. If you disconnect the USB cable, the icon will disappear.

USB

USB connected and working fine.



USB connected but not working properly.

USB port

Connect a USB cable to the USB port and download programs from your computer to the NXT (or upload data from the robot to your computer). You can also use the wireless Bluetooth connection for uploading and downloading.



Sensor ports

The NXT has four input ports for attaching sensors. The sensors need to be attached to port 1, 2, 3 or 4.

NXT TECHNOLOGY



Naming the NXT

You can change the name of your NXT by going to the NXT window in the software. This window is accessible from the Controller. NXT names can be at most eight characters long.

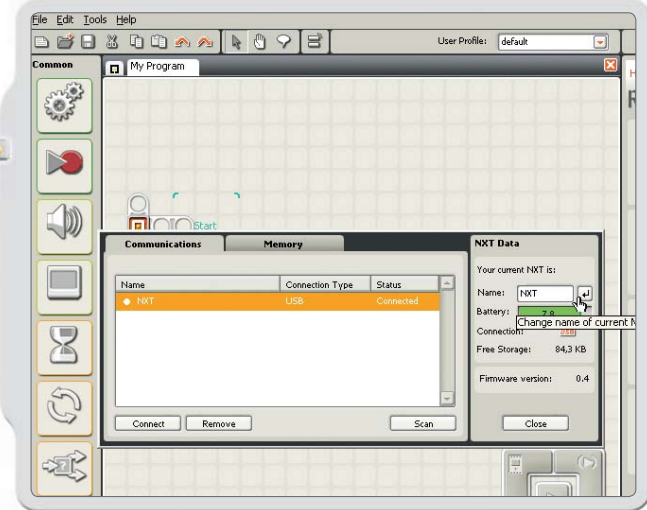

Battery level

The battery icon displays the power level of the NXT. When battery power is low, the battery icon will flash on and off.



Running icon

When your NXT is turned on, the running icon will spin. If the running icon stops spinning, your NXT has frozen and you will need to reset it (see page 74, Troubleshooting.)

Loudspeaker

Make a program with real sounds and listen to them when you run the program.

NXT buttons

Orange button: On/Enter
Light grey arrows: Used for moving left and right in the NXT menu.
Dark grey button: Clear/Go back

Turning off your NXT

Push the dark grey button repeatedly until you see the screen on the right.
Push the orange button to turn off your NXT; push the dark grey button to go back to the main menu.

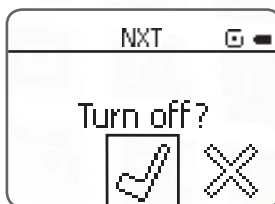

NXT display options

Your NXT has many other cool features. Read more about them on the following pages.



Technical specifications

- 32-bit ARM7 microcontroller
- 256 Kbytes FLASH, 64 Kbytes RAM
- 8-bit AVR microcontroller
- 4 Kbytes FLASH, 512 Byte RAM
- Bluetooth wireless communication (Bluetooth Class II V2.0 compliant)
- USB full speed port (12 Mbit/s)
- 4 input ports, 6-wire cable digital platform (One port includes a IEC 61158 Type 4/EN 50 170 compliant expansion port for future use)
- 3 output ports, 6-wire cable digital platform
- 100 x 64 pixel LCD graphical display
- Loudspeaker - 8 kHz sound quality. Sound channel with 8-bit resolution and 2-16 KHz sample rate.
- Power source: 6 AA batteries

INSTALLING BATTERIES IN YOUR NXT

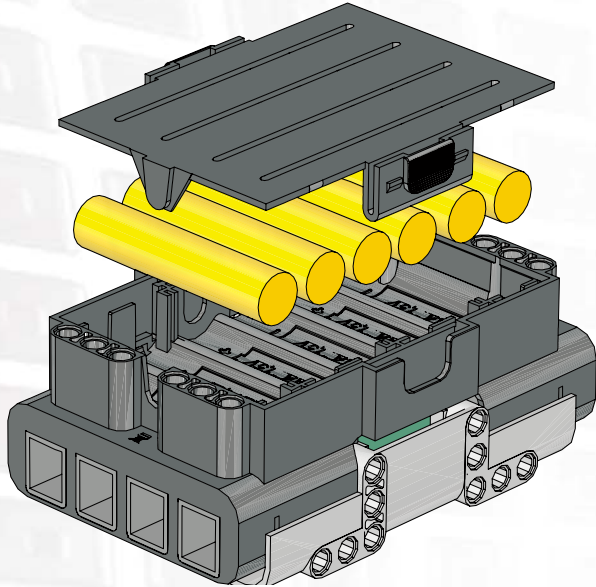

Battery type

- The NXT requires 6 AA/LR6 batteries to function properly.
- Alkaline batteries are recommended.
- Rechargeable batteries can be used, but the NXT's power may be reduced, making the motors turn more slowly.



Low battery power

When battery power is low, this icon will pop up on the NXT's display screen.

Important!

- Never mix different types of batteries in the NXT.
- Always remove batteries prior to long-term storage.
- Promptly remove depleted batteries from the NXT.
- Only recharge batteries under adult supervision.
- Never attempt to recharge non-rechargeable batteries.



NXT MAIN MENU

My Files

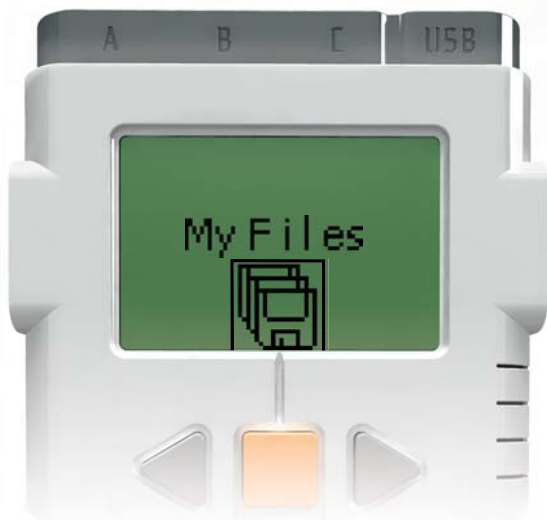

The My Files submenu will let you see all of the programs you have made on the NXT or downloaded from your computer.

Software files



Software files - programs you have downloaded from your computer

NXT files



NXT files - programs you have made on the NXT

Sound files



Sound files

Files will automatically be placed in the appropriate subfolders. When you download a program including a sound file to your NXT, the program will be placed under Software files, while the sound data will be placed under Sound files. You can send files to other NXTs. Read more about this on page 36.

NXT Program



You don't need a computer to program your robot. Using the NXT Program submenu, you can make thousands of different programs without your computer.

Try this simple program and see how easy it is:

Make the robot go back and forth when its Touch Sensor is pressed. First, the robot will move forward until the Touch Sensor is pressed, and then it will move backwards. When its Touch Sensor is pressed again, the robot will move forward once again. This will continue indefinitely until you stop the program.

Make sure that your sensors and motors are connected to the right ports.

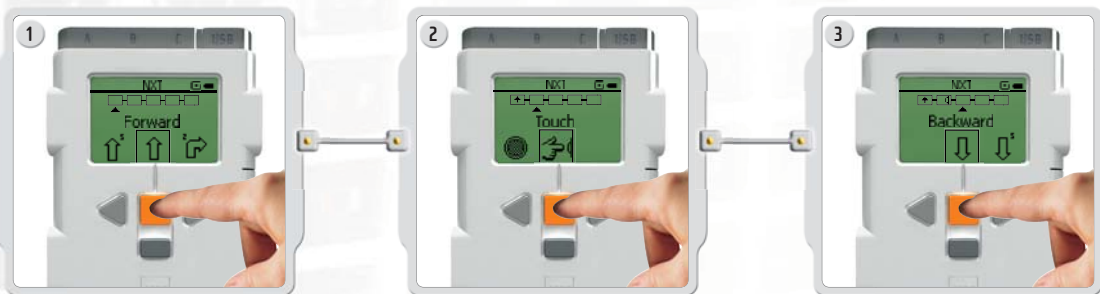

Select Forward. Use the arrow buttons to move through the choices and then press the orange button (Enter) to make your selection.

Select Touch.

Select Backward.

NXT TECHNOLOGY

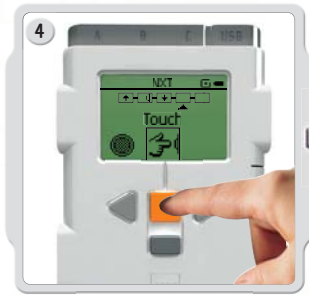

Select Touch again.

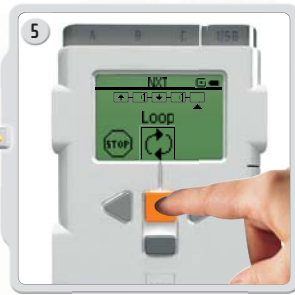





















Now select if you want the program to Loop. This means that the program will run again and again until you switch off the NXT. For our little test, select Loop.



Now you can run your program. Simply select Run!

Try these programs as well:

1.     
2.     
3.     
4.     

Try Me

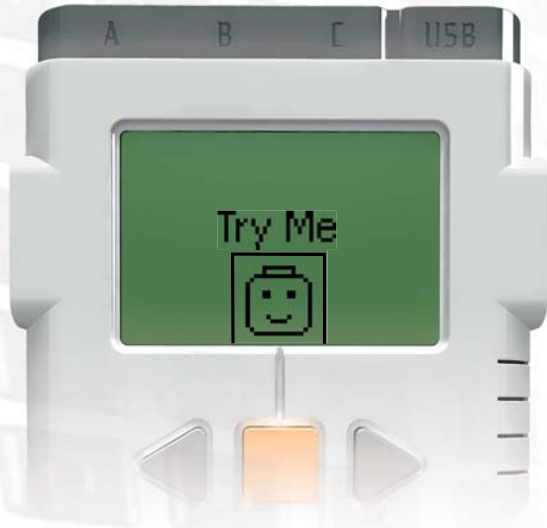

The Try Me submenu lets you test your sensors and motors in a fun way:



Connect the sensors and motors to the appropriate ports on the NXT. Important: Use the standard settings for the ports as explained on page 7.

Select a program.

When you press the orange (Enter) button, you will get some fun reactions from the sensors and motors.

Explore other Try Me programs to get some more fun sounds, to display images and to experience different motor reactions.

You can always delete these Try Me files again using the Settings submenu.

View

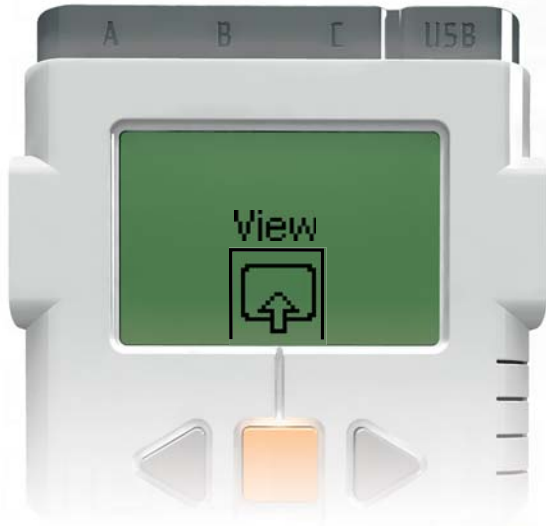

The View submenu lets you carry out a quick test of your sensors and motors, observing real-time data from each unit:

Connect the sensor or motor you would like to test to the NXT - the View submenu will help you select the right port or check standard settings on page 7. Select View on the NXT's display.

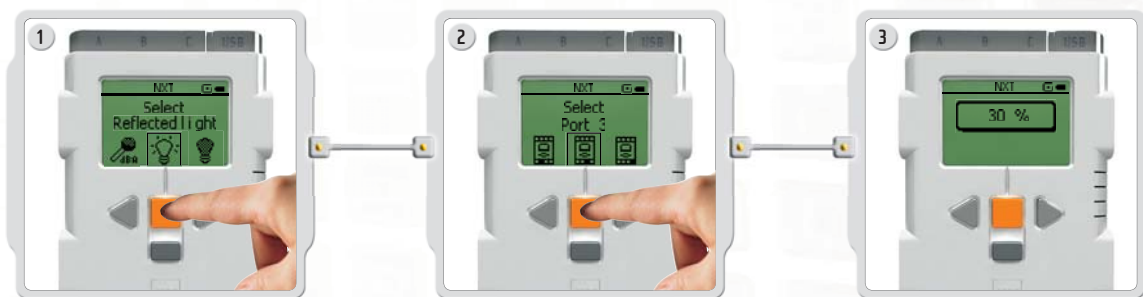

Select the icon of the sensor or motor you would like to test. You can only get readings from one sensor or motor at a time.

Select the port that the sensor or motor is attached to.

The data from the sensor or motor will appear on the display.

Settings

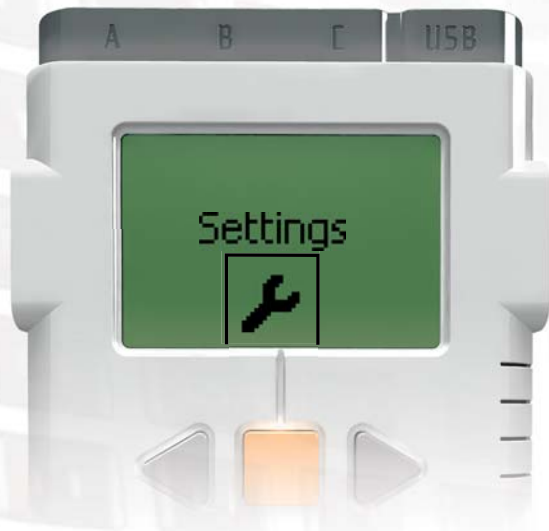

The Settings submenu lets you adjust the NXT's settings including its speaker volume or the Sleep mode setting. This submenu will also let you delete programs that have been stored in the NXT's memory.

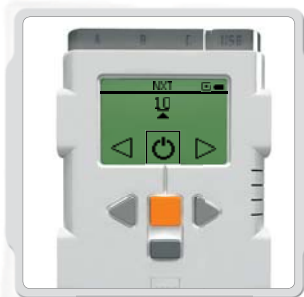

Sleep mode: You can set the NXT to turn itself off after 2, 5, 10, 30 or 60 minutes of inactivity (time when its not in use). You can also select the Never setting so that it remains on indefinitely (until you turn it off). Please be aware that the Never setting will drain your batteries more quickly.

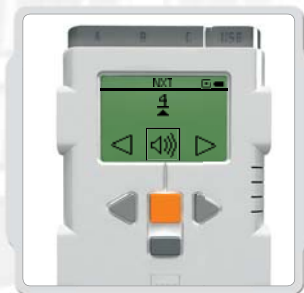

Change volume:
Here you can adjust the volume of the NXT's speakers.



Delete all programs:
You are able to delete all downloaded programs in the 3 sub folders: Software files, NXT files, Sound files, from the Settings submenu.

Bluetooth

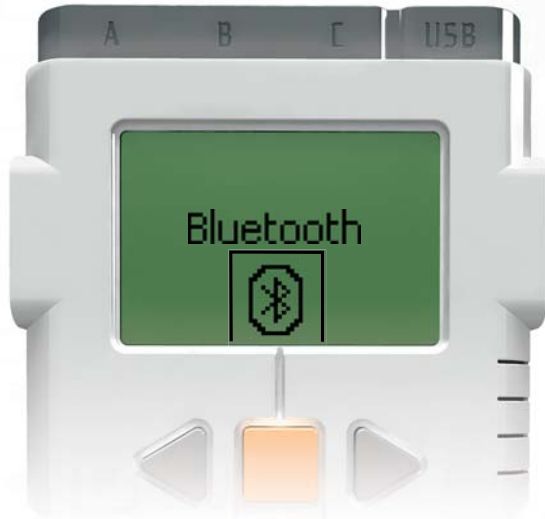

The Bluetooth submenu will let you make a wireless connection between your NXT and other Bluetooth devices (like other NXTs, mobile phones, and computers). You can use a wireless Bluetooth connection to send programs to other NXTs, to download programs from your own computer without using a USB cable, and lots of other cool things, such as using your mobile phone to control your robot! Read more about wireless Bluetooth communications on pages 28.

NXT TECHNOLOGY

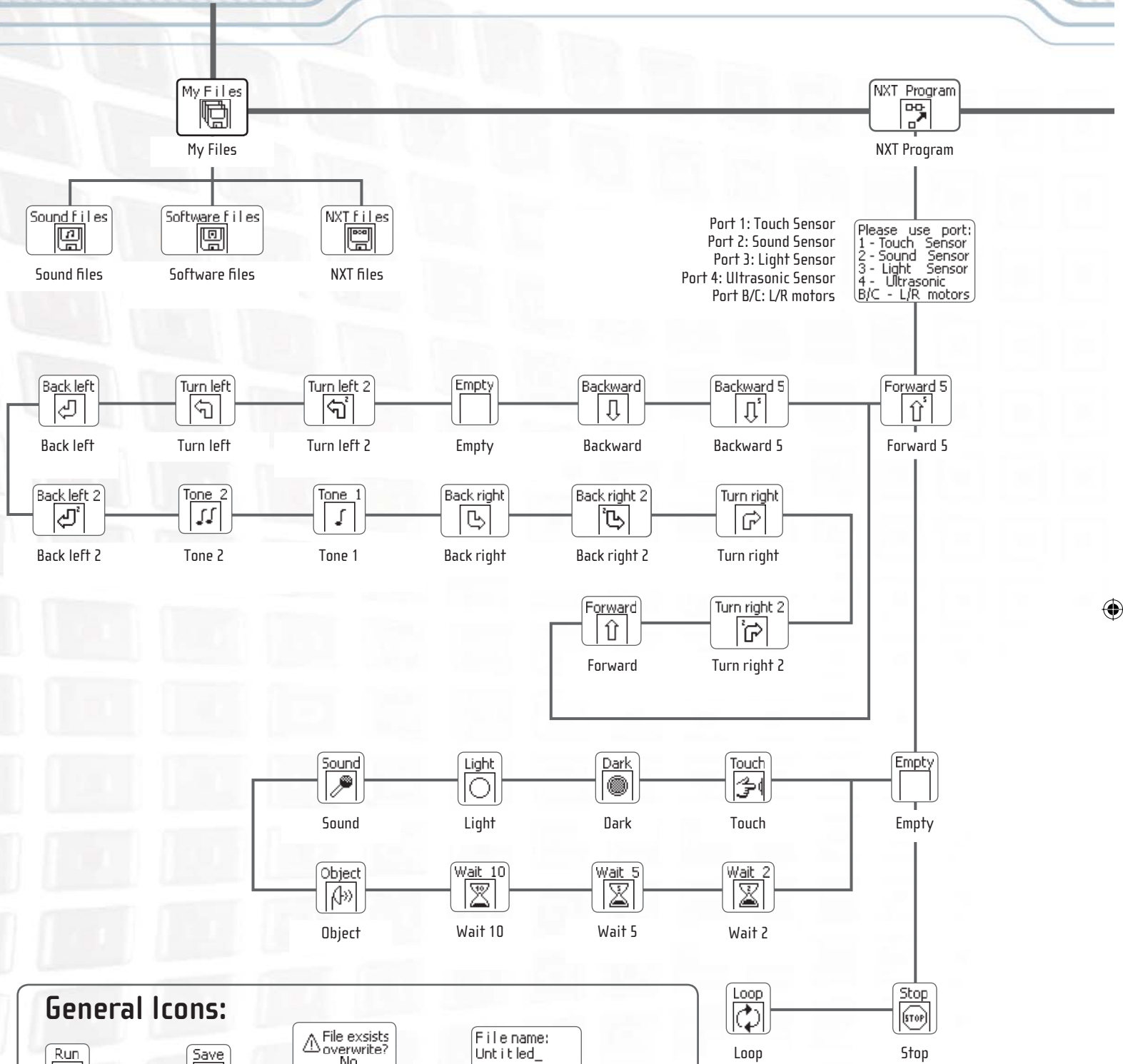

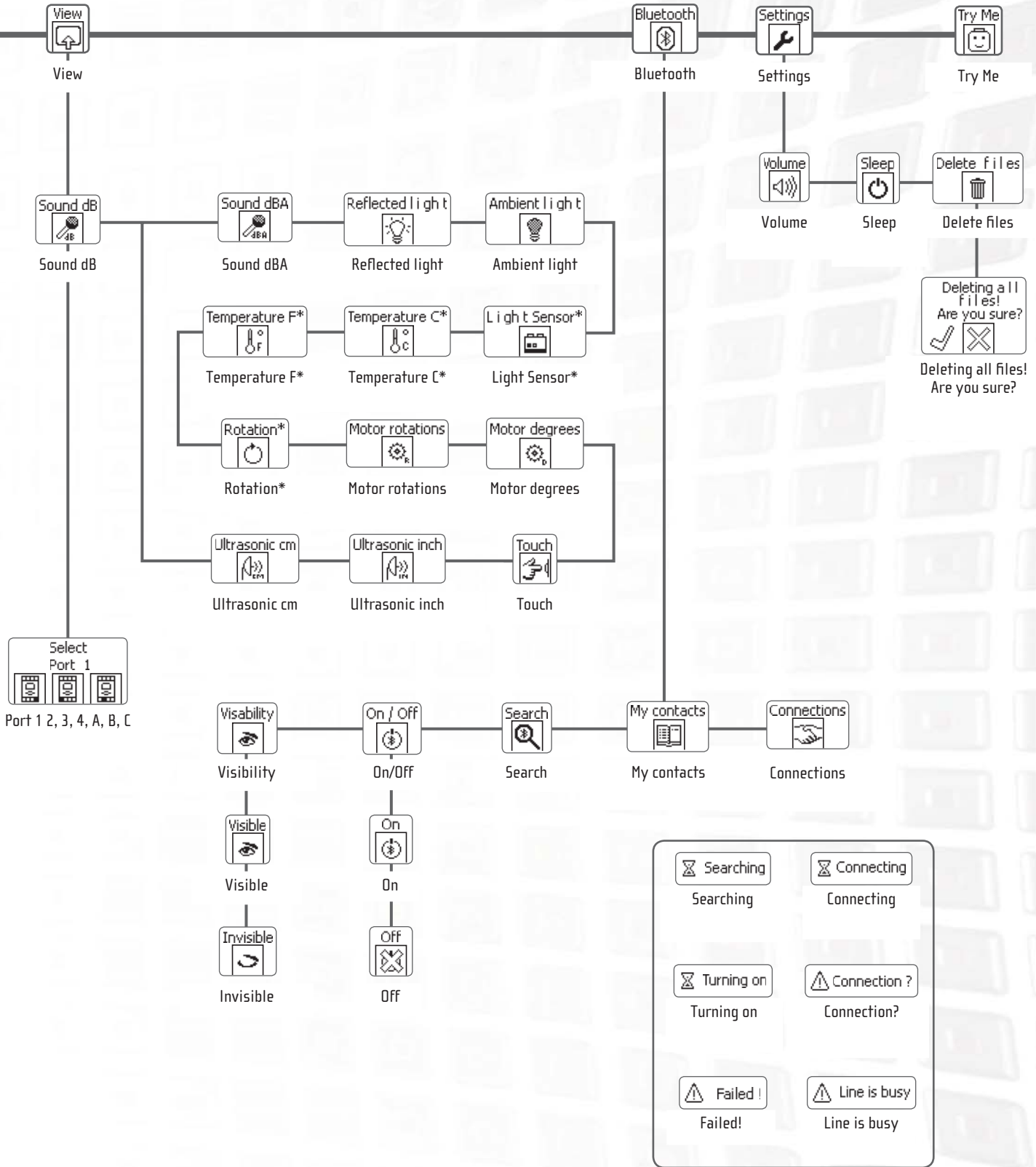

TOUCH SENSOR

The Touch Sensor gives your robot a sense of touch. The Touch Sensor detects when it is being pressed by something and when it is released again.

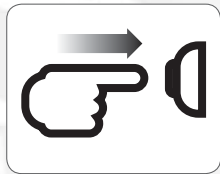

Pressed

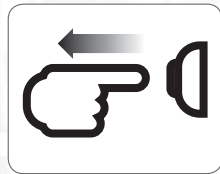

Released

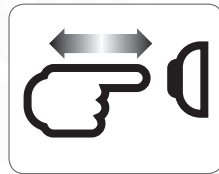

Bumped



Suggestions for use

You can use the Touch Sensor to make your robot pick up things: a robotic arm equipped with a Touch Sensor lets the robot know whether or not there is something in its arm to grab. Or you can use a Touch Sensor to make your robot act on a command. For example, by pressing the Touch Sensor you can make your robot walk, talk, close a door, or turn on your TV.

Try Me



Test it!

Test the Touch Sensor and get a fun reaction. Connect a Touch Sensor to port 1 of your NXT and select the Try-Touch program in the Try Me submenu on the NXT's display.



SOUND SENSOR

The Sound Sensor makes your robot hear!

The Sound Sensor can detect both decibels (dB) and adjusted decibels (dBA). A decibel is a measurement of sound pressure.

dBA: In detecting adjusted decibels, the sensitivity of the sensor is adapted to the sensitivity of the human ear. In other words, these are sounds that your ears are able to hear.

dB: In detecting standard (unadjusted) decibels, all sounds are measured with equal sensitivity. Thus, these sounds may include some that are too high or low for the human ear to hear.

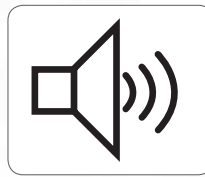

The Sound Sensor can measure sound pressure levels up to 90 dB - about the level of a lawnmower. Sound pressure levels are extremely complicated, so the Sound Sensor readings on the MINDSTORMS® NXT are displayed in percent (%). To give some comparative examples: 4-5% is like a silent living room. 5-10% would be the reading you get from someone talking some distance away. 10-30 % is normal conversation close to the sensor or music played at a normal level. And you will record readings of 30-100% from people shouting and music played at high volumes.



Suggestions for use

You can use the Sound Sensor to make a sound controlled robot. Talk to your robot and it will answer you back. Clap your hands and the robot can pick up things and bring them to you.

Test it!

Test the Sound Sensor's ability to read sound volume:

Connect the Sound Sensor to the NXT.

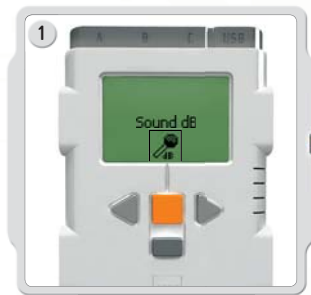

1 Select the View submenu on the NXT's display. Select the Sound Sensor icon and the port where you have connected the sensor.



2 Make some sounds into the Sound Sensor and watch the readings displayed on the NXT. Use the sensor to read some sounds around you. How loud do your parents speak? How loud is your front doorbell?

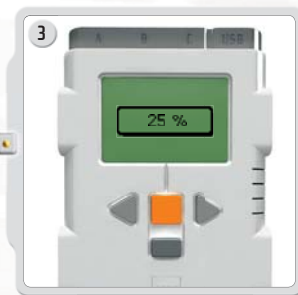

Select the Try Me submenu on the NXT's display and test your Sound Sensor. You'll get a fun reaction.

LIGHT SENSOR

The Light Sensor is one of the two sensors that give your robot vision (the Ultrasonic Sensor is the other). The Light Sensor enables your robot to distinguish between light and dark. It can read the light intensity in a room and measure the light intensity of colored surfaces.

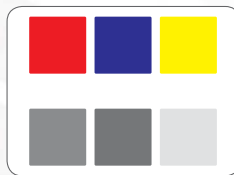
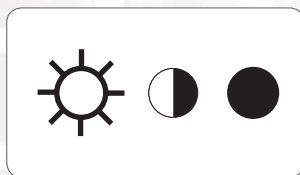
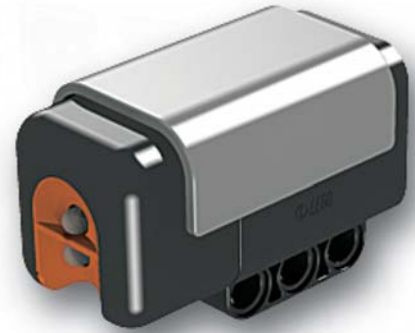

This is what your eyes see.

This is what your robot will see, using the light sensor.



Suggestions for use

You can use the Light Sensor to make a burglar alarm robot: when an intruder turns on the light in your room, the robot can react to defend your property. You can also use the Light Sensor to make a line-following robot or a robot that can sort things by color.

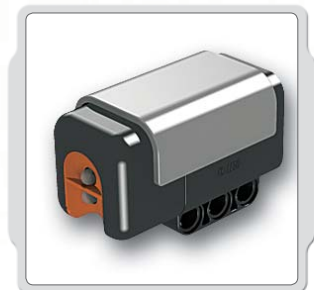

Detecting ambient (surrounding) light

Test the Light Sensor's ability to read ambient light by measuring the light level in different locations of the room. For example, first hold the sensor against the window. Then hold it under the table. Watch how the readings differ.

Test it!

You can test the Light Sensor in different ways: Connect the Light Sensor to the NXT.



Select the View submenu on the NXT's display. Select the Light Sensor icon and the port where you have connected the sensor.

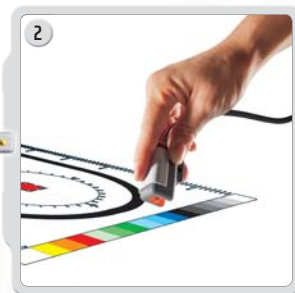

Hold the Light Sensor up to the different colors on the test pad and see the different readings.

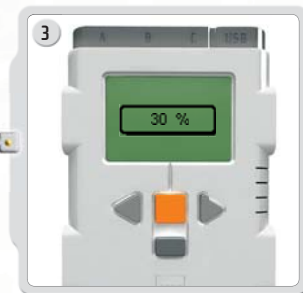

Select the Try Me submenu on the NXT's display and test your Light Sensor. You'll get a fun reaction.

ULTRASONIC SENSOR

The Ultrasonic Sensor is the other sensor that gives your robot vision. The Ultrasonic Sensor enables the robot to see and detect objects. You can also use it to make your robot avoid obstacles, sense and measure distance, and detect movement.

The Ultrasonic Sensor measures distance in centimeters and in inches on the NXT. It is able to measure distances from 0 to 255 centimeters with a precision of +/-3 cm.

The Ultrasonic Sensor uses the same scientific principle as bats: it measures distance by calculating the time it takes for a sound wave to hit an object and return – just like an echo.

Large-sized objects with hard surfaces return the best readings. Objects made of soft fabric or that are curved (like a ball) or are very thin or small can be difficult for the sensor to detect.

Note that two or more Ultrasonic Sensors operating in the same room may interfere with each other's readings.

Test it!

Test the Ultrasonic Sensor's ability to measure distance:
Connect the Ultrasonic Sensor to the NXT.
Select the View submenu in the NXT display.

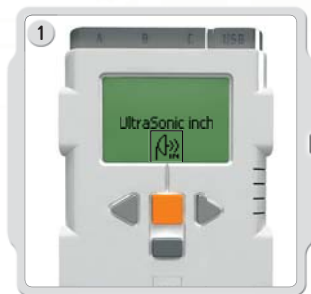

Select the Ultrasonic Sensor icon and the port where you've connected the sensor.



Measure the distance to an object. For example, move your hand closer to the sensor and watch the readings change.

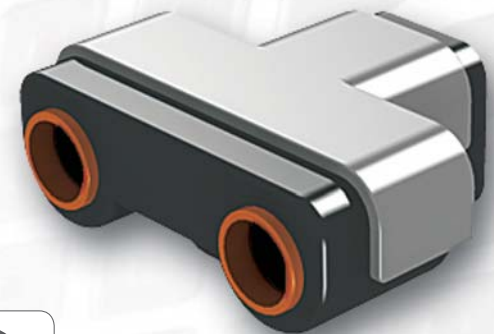

Suggestions for use

You can use the Ultrasonic Sensor in many different ways. Program a robot to sneak around the house without it bumping into things. Or make an advanced burglar alarm robot that reacts to movement as well as light. Your Scorpion robot "stings" if you come too close.

Select the Try Me submenu on the NXT's display and test your Ultrasonic Sensor. You'll get a fun reaction.



INTERACTIVE SERVO MOTORS

The three Servo Motors give your robot the ability to move. If you use the Move block in the software to program your motors, the two motors will automatically synchronize, so that your robot will move in a straight line.

Built-in Rotation Sensor

Each motor has a built-in Rotation Sensor. This lets you control your robot's movements precisely. The Rotation Sensor measures motor rotations in degrees or full rotations (accuracy of +/- one degree). One rotation is equal to 360 degrees, so if you set a motor to turn 180 degrees, its output shaft will make half a turn.

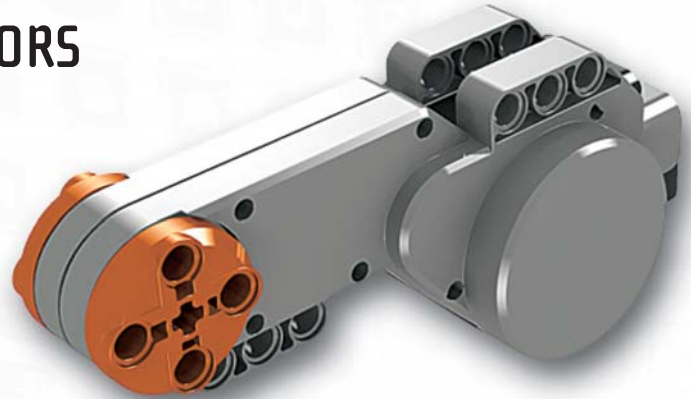

The built-in Rotation Sensor in each motor also lets you set different speeds for your motors (by setting different power parameters in the software). Try running the motors at different speeds.

Test it!

Test the built-in Rotation Sensor's ability to measure distance:
Connect a motor to the NXT.

Select the View submenu in the NXT's display.



Select the Motor Rotations icon. Select the port where you have connected the motor.

Now attach a wheel to the motor and measure the rotations as you roll the wheel along the floor.

Select the Try Me submenu on the NXT's display and test your motors. You'll get a fun reaction.

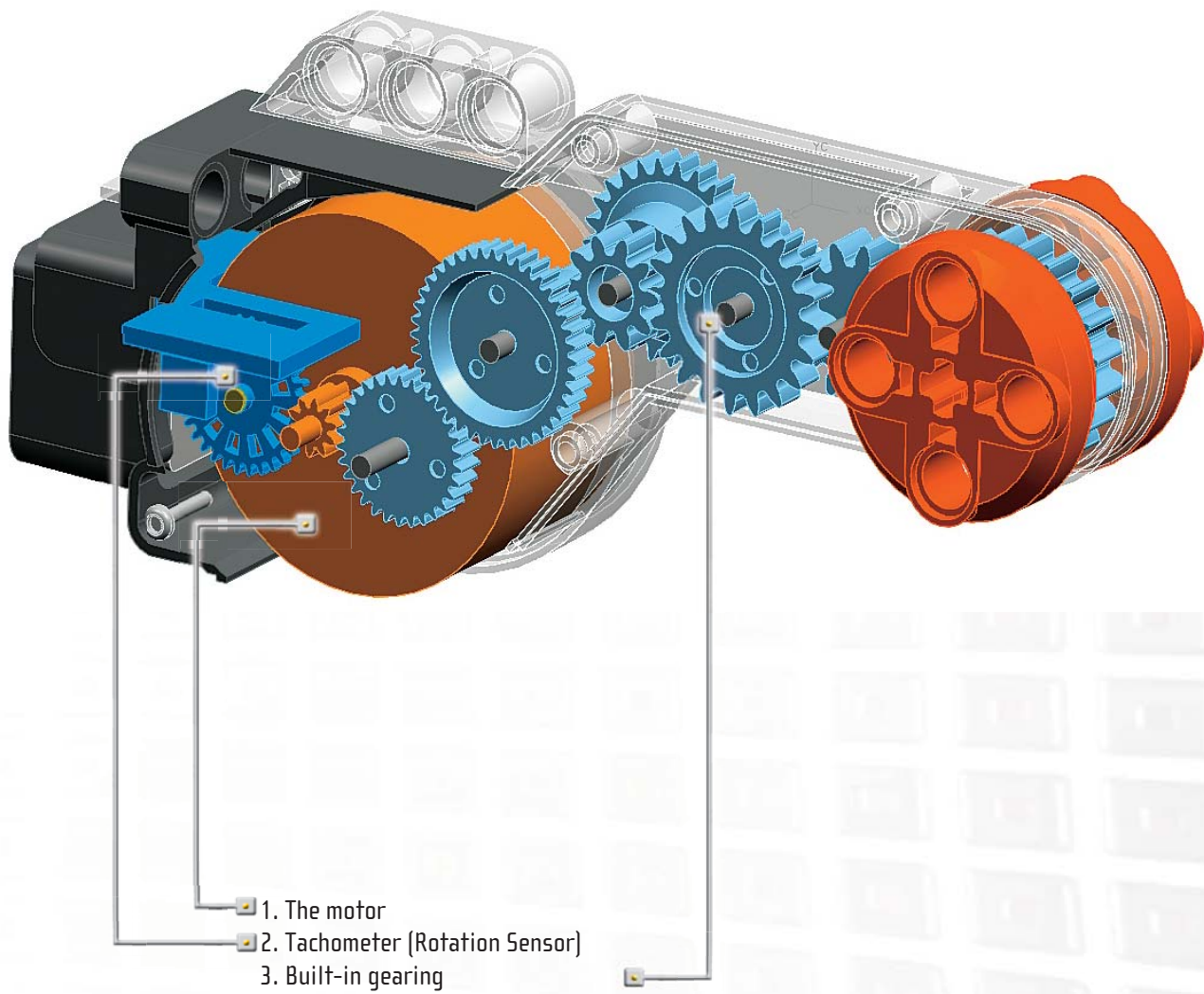

Bluetooth[®] USING BLUETOOTH



Bluetooth is a technology that makes it possible to send and receive data without using wires or cables. Using Bluetooth, you can exchange programs between your NXT and other NXTs. Or you can establish a wireless connection between your computer and your robot and try out programs instantly – even with your robot on the other side of the room!

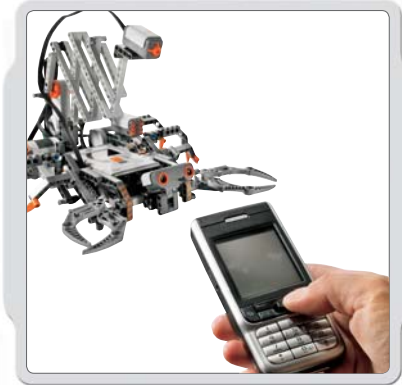

If you have a mobile phone with Bluetooth capability, you can use it to control your robot. You might even be able to use it as an advanced sensor, like a camera sensor. Visit www.MINDSTORMS.com/bluetooth, for more information on mobile phone requirements.