

**KTL Test Report No.:** 0L0471RUS1

**Applicant:** Samsung Telecommunications America  
1130 Arapaho Road  
Richardson, Texas 75081

**Equipment Under Test:** Indoor BTS

**FCC ID:** NP8SCBS-419L

**In Accordance With:** **FCC Part 24, Subpart E**  
Broadband PCS Base Station Transmitter

**Tested By:** KTL Dallas Inc.  
802 N. Kealy  
Lewisville, Texas 75057-3136  

**Authorized By:** Tom Tidwell, Wireless Group Manager

**Date:** 12/21/00

**Total Number of Pages:** 36

**Table of Contents**

Section 1. Summary of Test Results ..... 3

Section 2. General Equipment Specification..... 5

Section 3. RF Power Output..... 8

Test Data - RF Power Output ..... 9

Test Data - Occupied Bandwidth (CDMA)..... 11

Section 5. Spurious Emissions at Antenna Terminals ..... 14

Test Data - Spurious Emissions at Antenna Terminals ..... 15

Test Data - Spurious Emissions at Antenna Terminals ..... 16

Test Data - Spurious Emissions at Antenna Terminals ..... 17

Test Data - Spurious Emissions at Antenna Terminals ..... 18

Test Data - Spurious Emissions at Antenna Terminals ..... 19

Section 6. Field Strength of Spurious..... 20

Section 7. Frequency Stability ..... 24

Test data - Frequency Stability ..... 25

Section 8. Test Equipment List..... 26

ANNEX A - TEST DETAILS ..... 27

ANNEX B - TEST DIAGRAMS ..... 33

*EQUIPMENT:* SCBS-419L Indoor BTS

*FCC ID:* NP8SCBS-419L

REPORT NO.: 0L0471RUS1

---

**Section 1. Summary of Test Results**

Manufacturer: Samsung Telecommunications

Model No.: SCBS-419L

Serial No.: None

General: **All measurements are traceable to national standards.**

These tests were conducted on a sample of the equipment for the purpose of demonstrating compliance with FCC Part 24, Subpart E.



New Submission



Production Unit



Class II Permissive Change



Pre-Production Unit

THIS TEST REPORT RELATES ONLY TO THE ITEM(S) TESTED.

THE FOLLOWING DEVIATIONS FROM, ADDITIONS TO, OR EXCLUSIONS FROM THE TEST SPECIFICATIONS HAVE BEEN MADE.

See " Summary of Test Data".



**NVLAP LAB CODE: 100426-0**

KTL Dallas Inc. authorizes the above named company to reproduce this report provided it is reproduced in its entirety and for use by the company's employees only.

Any use which a third party makes of this report, or any reliance on or decisions to be made based on it, are the responsibility of such third parties. KTL Dallas Inc. accepts no responsibility for damages, if any, suffered by any third party as a result of decisions made or actions based on this report.

This report applies only to the items tested.

EQUIPMENT: SCBS-419L Indoor BTS

FCC ID: NP8SCBS-419L

REPORT NO.: 0L0471RUS1

**Summary Of Test Data**

NAME OF TEST	PARA. NO.	SPEC.	MEAS.	RESULT
RF Power Output	24.232	100W	18W	Complies
Occupied Bandwidth (CDMA)	24.238	Graph	Graph	Complies
Occupied Bandwidth (GSM)	24.238	N/A	N/A	N/A
Occupied Bandwidth (NADC)	24.238	N/A	N/A	N/A
Spurious Emissions at Antenna Terminals	24.238(a)	-13 dBm	> -13 dBm	Complies
Field Strength of Spurious Emissions	24.238(a)	-13 dBm E.R.P.	< -39 dBm	Complies
Frequency Stability	24.235	Must remain within the authorized band	Maximum freq. error -106 Hz	Complies

**Footnotes:**

1. The E.U.T. is CDMA only.

**Measurement uncertainty is expressed to a confidence level of 95%.**

**Section 2. General Equipment Specification**

<b>Supply Voltage Input:</b>	+26 Vdc		
<b>Frequency Bands: TX</b>	<input checked="" type="checkbox"/>	Block A :	1930 – 1945 MHz
	<input checked="" type="checkbox"/>	Block D :	1945 – 1950 MHz
	<input checked="" type="checkbox"/>	Block B :	1950 – 1965 MHz
	<input checked="" type="checkbox"/>	Block E :	1965 – 1970 MHz
	<input checked="" type="checkbox"/>	Block F :	1970 – 1975 MHz
	<input checked="" type="checkbox"/>	Block C :	1975 – 1990 MHz
<b>Frequency Bands: RX</b>	<input checked="" type="checkbox"/>	Block A :	1850 – 1865 MHz
	<input checked="" type="checkbox"/>	Block B :	1865 – 1870 MHz
	<input checked="" type="checkbox"/>	Block C :	1870 – 1885 MHz
	<input checked="" type="checkbox"/>	Block D :	1885 – 1890 MHz
	<input checked="" type="checkbox"/>	Block E :	1890 – 1895 MHz
	<input checked="" type="checkbox"/>	Block F :	1895 – 1910 MHz
<b>Type of Modulation and Designator:</b>	<b>CDMA</b> (1M25G7W) <input checked="" type="checkbox"/>	<b>GSM</b> (200KGXW) <input type="checkbox"/>	<b>NADC</b> (40K0DXW) <input type="checkbox"/>
<b>Maximum No. of Carriers:</b>	3		
<b>Output Impedance:</b>	50 ohms		
<b>RF Output (Rated):</b>	Per channel:	20 W	
	Total:	60 W	
<b>Band Selection:</b>	<b>Software</b> <input checked="" type="checkbox"/>	<b>Duplexer</b> <input checked="" type="checkbox"/>	<b>Fullband</b> <input type="checkbox"/>

*EQUIPMENT:* SCBS-419L Indoor BTS

*FCC ID:* NP8SCBS-419L

REPORT NO.: 0L0471RUS1

---

**Description of Modifications For Class II Permissive Change**

**Not Applicable**

### System Description

The SCBS-419L BTS is a PCS band base station transceiver for use in CDMA wireless systems. The modulation used is QPSK and the access protocol is CDMA IS-98. The BTS can transmit up to 3 carriers with a nominal rf power output level of 20W/carrier. The maximum total rf output power is, therefore, 60 W.

The SCBS-419L is housed in an indoor type enclosure but is connected to an antenna mounted on a permanent outdoor structure.

### System Diagram

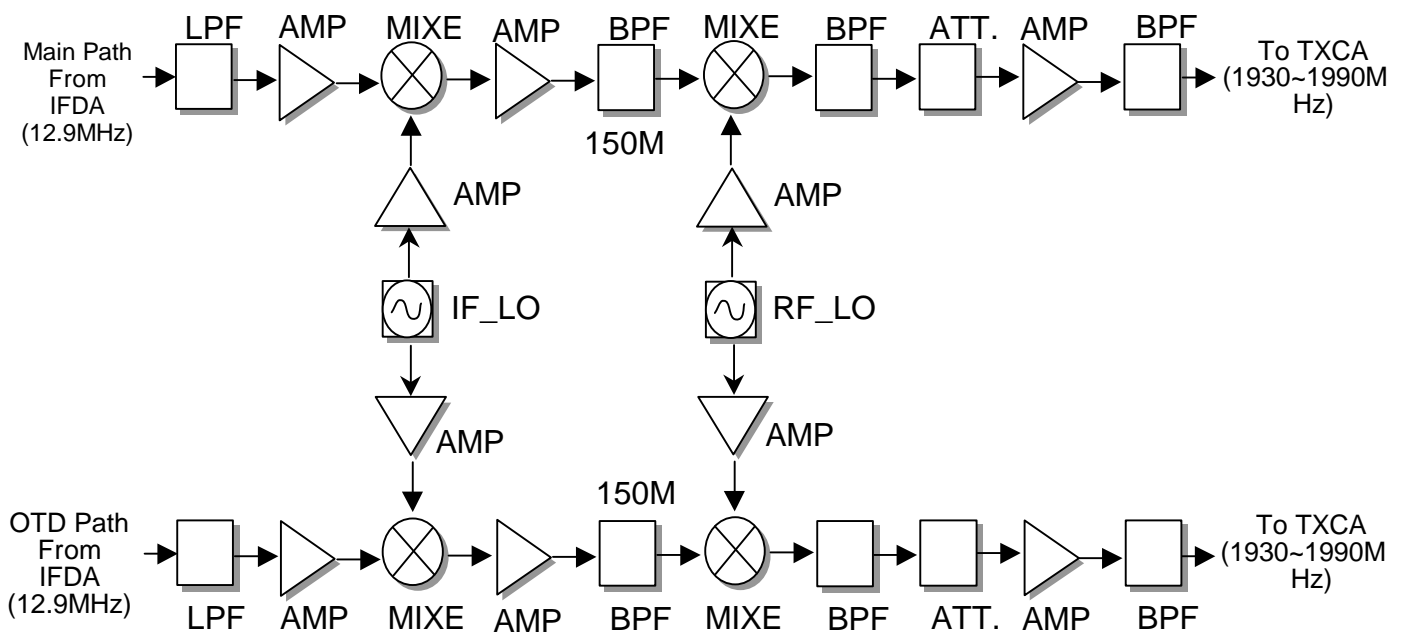

*EQUIPMENT:* SCBS-419L Indoor BTS

*FCC ID:* NP8SCBS-419L

REPORT NO.: 0L0471RUS1

**Section 3. RF Power Output**

NAME OF TEST: RF Power Output	PARA. NO.: 2.1046
TESTED BY: David Light	DATE: 12/14/00

**Test Results:** Complies.

**Measurement Data:**

Modulation Type	Measured Output Power (dBm)	External Cable Loss (dB)	Corrected Output Power (dBm)	Rated Output Power (dBm)	Measured/Rated Output Power (dB)
CDMA	+41.75	0.8	+42.55	+43.0	-0.45
GSM	N/A	N/A		N/A	N/A
NADC	N/A	N/A		N/A	N/A



EQUIPMENT: SCBS-419L Indoor BTS

FCC ID: NP8SCBS-419L

REPORT NO.: 0L0471RUS1

### Test Data - RF Power Output

Test Plot: RF POWER OUT	
Page 1 of 1	
Job No.: 0L0471R	Date: 12/14/00
Specification: PART 24	Temperature(°C): 22
Tested By: David Light	Relative Humidity(%): 50
E.U.T.: INDOOR BTS	
Configuration: TRANSMIT ONE CDMA CHANNEL - FULL POWER - C BLOCK	
Serial Number: NONE	
Location: SAMSUNG (IN SITU)	RBW: 30 kHz
Detector Type: Rms	VBW: 300 kHz
<b>Test Equipment Used</b>	
Antenna: #N/A	Directional Coupler: #N/A
Pre-Amp: #N/A	Cable #1: #N/A
Filter: #N/A	Cable #2: #N/A
Receiver: 1036	Cable #3: #N/A
Attenuator #1: 1471	Cable #4: #N/A
Attenuator #2: #N/A	Mixer: #N/A
Additional equipment used: 1048 BIRD ATTENUATOR MODEL 1000-WA-FFN-30 (PROPERTY OF SAMSUNG)	
Measurement Uncertainty: #N/A	

Ref Lvl	50 dBm	Marker 1 [T1]	27.92 dBm	RBW	30 kHz	RF Att	10 dB
			1.98249110 GHz	VBW	300 kHz	Mixer	-10 dBm
				SWT	7 ms	Unit	dBm

50 dB Offset

▼1 [T1] 27.92 dBm

1.98249110 GHz

CH PWR 41.75 dBm

CH BW 1.23000000 MHz

1 MAX

Paste Plot Here

Center 1.982508078 GHz 246 kHz

Span 2.46 MHz

Date: 14.DEC.2000 14:18:06

Notes:

---

*EQUIPMENT:* SCBS-419L Indoor BTS

*FCC ID:* NP8SCBS-419L

REPORT NO.: 0L0471RUS1

---

NAME OF TEST: Occupied Bandwidth (CDMA)	PARA. NO.: 2.1049
TESTED BY: David Light	DATE: 12/14/00

**Test Results:** Complies.

**Test Data:** See attached plot(s).

EQUIPMENT: SCBS-419L Indoor BTS

FCC ID: NP8SCBS-419L

REPORT NO.: 0L0471RUS1

Test Data - Occupied Bandwidth (CDMA)

Test Plot: RF POWER OUT

Page 1 of 1  
 Job No.: 0L0471R Date: 12/14/00  
 Specification: PART 24 Temperature(°C): 22  
 Tested By: David Light Relative Humidity(%) 50  
 E.U.T.: INDOOR BTS  
 Configuration: TRANSMIT ONE CDMA CHANNEL - FULL POWER - C BLOCK  
 Serial Number: NONE  
 Location: SAMSUNG (IN SITU) RBW: 30 kHz  
 Detector Type: Peak VBW: 30 kHz

Test Equipment Used

Antenna:	#N/A	Directional Coupler:	#N/A
Pre-Amp:	#N/A	Cable #1:	#N/A
Filter:	#N/A	Cable #2:	#N/A
Receiver:	1036	Cable #3:	#N/A
Attenuator #1:	1471	Cable #4:	#N/A
Attenuator #2:	#N/A	Mixer:	#N/A

Additional equipment used: 1048 BIRD ATTENUATOR MODEL 1000-WA-FFN-30 (PROPERTY OF SAMSUNG)  
 Measurement Uncertainty: #N/A

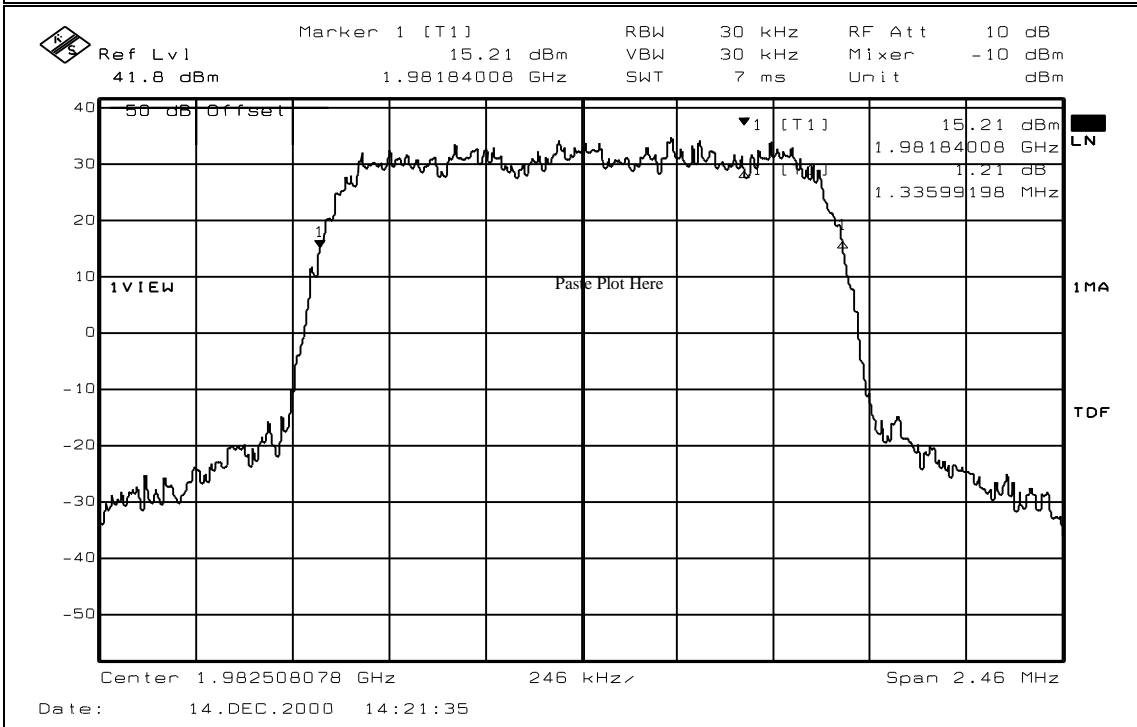

Notes:

---



---



---

*EQUIPMENT:* SCBS-419L Indoor BTS

*FCC ID:* NP8SCBS-419L

REPORT NO.: 0L0471RUS1

---

NAME OF TEST: Occupied Bandwidth (GSM)	PARA. NO.: 2.1049
TESTED BY:	DATE:

**Test Results:**

Complies.

**Test Data:**

See attached reports.

**Equipment Used:**

**Measurement Uncertainty:** +/- 1.6 dB

**Temperature:** °C

**Relative Humidity:** %

**Not Applicable**

*EQUIPMENT:* SCBS-419L Indoor BTS

*FCC ID:* NP8SCBS-419L

REPORT NO.: 0L0471RUS1

---

NAME OF TEST: Occupied Bandwidth (NADC)	PARA. NO.: 2.1049
TESTED BY:	DATE:

**Test Results:** Complies.

**Test Data:** See attached to

**Equipment Used:**

**Not Applicable**

**Measurement Uncertainty:** +/- 1.6 dB

**Temperature:** °C

**Relative Humidity:** %

*EQUIPMENT:* SCBS-419L Indoor BTS

*FCC ID:* NP8SCBS-419L

REPORT NO.: 0L0471RUS1

---

**Section 5. Spurious Emissions at Antenna Terminals**

NAME OF TEST: Spurious Emissions @ Antenna Terminals	PARA. NO.: 2.1051
TESTED BY: David Light	DATE: 12/14/00

**Test Results:** Complies.

**Test Data:**

See attached plots

EQUIPMENT: SCBS-419L Indoor BTS

FCC ID: NP8SCBS-419L

REPORT NO.: 0L0471RUS1

### Test Data - Spurious Emissions at Antenna Terminals

**Test Plot: ANTENNA PORT SPURIOUS**

Page 1 of 2

Job No.: 0L0471R Date: 12/14/00  
 Specification: PART 24 Temperature(°C): 22  
 Tested By: David Light Relative Humidity(%) 50  
 E.U.T.: INDOOR BTS  
 Configuration: TRANSMIT ONE CDMA CHANNEL - FULL POWER - C BLOCK  
 Serial Number: NONE  
 Location: SAMSUNG (IN SITU) RBW: 100 kHz < 1 GHz, 1 MHz > 1 GHz  
 Detector Type: Peak VBW: 100 kHz < 1 GHz, 1 MHz > 1 GHz

**Test Equipment Used**

Antenna:	#N/A	Directional Coupler:	#N/A
Pre-Amp:	#N/A	Cable #1:	#N/A
Filter:	#N/A	Cable #2:	#N/A
Receiver:	1036	Cable #3:	#N/A
Attenuator #1:	1471	Cable #4:	#N/A
Attenuator #2:	#N/A	Mixer:	#N/A

Additional equipment used: 1048 BIRD ATTENUATOR MODEL 1000-WA-FFN-30 (PROPERTY OF SAMSUNG)  
 Measurement Uncertainty: #N/A

Ref Lvl	44.1 dBm	Marker 1 [1]	-28.49 dBm	RBW	100 kHz	RF Att	10 dB
			624.82965932 MHz	VBW	100 kHz	Mixer	-10 dBm
				SWT	245 ms	Unit	dBm

Start 30 MHz 97 MHz Stop 1 GHz

Date: 14.DEC.2000 13:17:10

Notes:

---

**EQUIPMENT:** SCBS-419L Indoor BTS

**FCC ID:** NP8SCBS-419L

**REPORT NO.:** 0L0471RUS1

**Test Data - Spurious Emissions at Antenna Terminals**

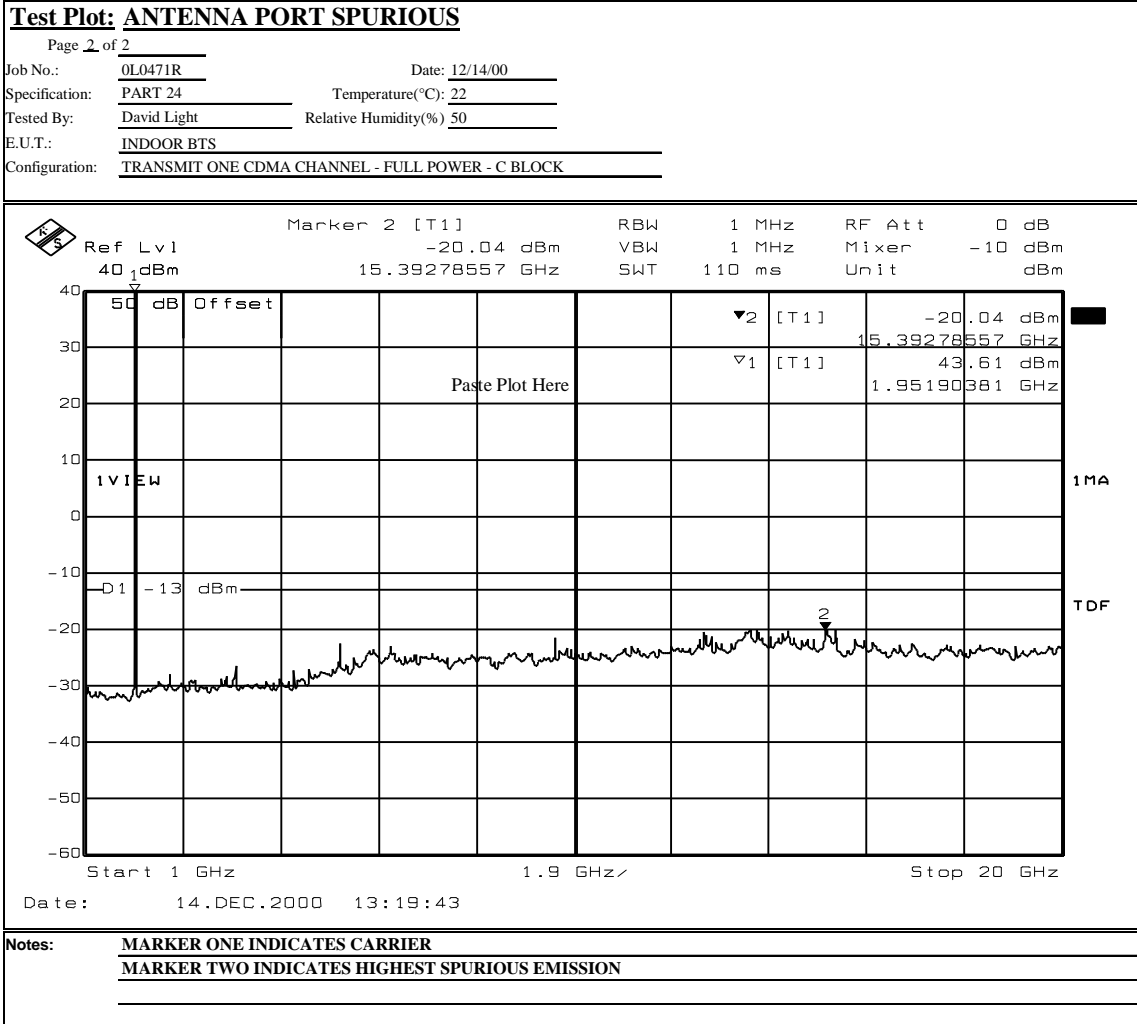



EQUIPMENT: SCBS-419L Indoor BTS

FCC ID: NP8SCBS-419L

REPORT NO.: 0L0471RUS1

### Test Data - Spurious Emissions at Antenna Terminals

**Test Plot: LOWER BANDEDGE**

Page 1 of 1

Job No.: 0L0471R Date: 12/14/00  
 Specification: PART 24 Temperature(°C): 22  
 Tested By: David Light Relative Humidity(%) 50  
 E.U.T.: INDOOR BTS  
 Configuration: TRANSMIT ONE CDMA CHANNEL - FULL POWER - CHANNEL 25  
 Serial Number: NONE  
 Location: SAMSUNG (IN SITU) RBW: 30 kHz  
 Detector Type: Peak VBW: 30 kHz

**Test Equipment Used**

Antenna: #N/A	Directional Coupler: #N/A
Pre-Amp: #N/A	Cable #1: #N/A
Filter: #N/A	Cable #2: #N/A
Receiver: 1036	Cable #3: #N/A
Attenuator #1: 1471	Cable #4: #N/A
Attenuator #2: #N/A	Mixer: #N/A

Additional equipment used: 1048 BIRD ATTENUATOR MODEL 1000-WA-FFN-30 (PROPERTY OF SAMSUNG)  
 Measurement Uncertainty: #N/A

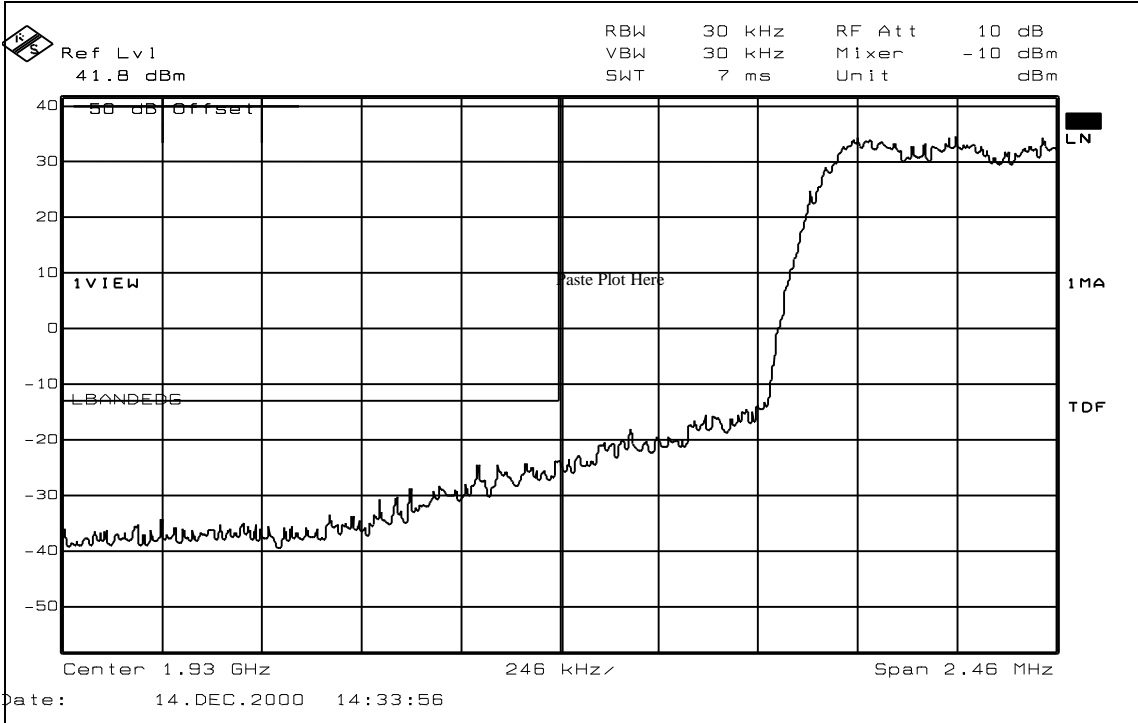

Notes:

---



---



---

**EQUIPMENT:** SCBS-419L Indoor BTS

**FCC ID:** NP8SCBS-419L

**REPORT NO.:** 0L0471RUS1

### Test Data - Spurious Emissions at Antenna Terminals

**Test Plot: UPPER BANDEDGE**

Page 1 of 1  
 Job No.: 0L0471R Date: 12/14/00  
 Specification: PART 24 Temperature(°C): 22  
 Tested By: David Light Relative Humidity(%) 50  
 E.U.T.: INDOOR BTS  
 Configuration: TRANSMIT ONE CDMA CHANNEL - FULL POWER - CHANNEL 1175  
 Serial Number: NONE  
 Location: SAMSUNG (IN SITU) RBW: 30 kHz  
 Detector Type: Peak VBW: 30 kHz

**Test Equipment Used**

Antenna:	#N/A	Directional Coupler:	#N/A
Pre-Amp:	#N/A	Cable #1:	#N/A
Filter:	#N/A	Cable #2:	#N/A
Receiver:	1036	Cable #3:	#N/A
Attenuator #1:	1471	Cable #4:	#N/A
Attenuator #2:	#N/A	Mixer:	#N/A

Additional equipment used: 1048 BIRD ATTENUATOR MODEL 1000-WA-FFN-30 (PROPERTY OF SAMSUNG)  
 Measurement Uncertainty: #N/A

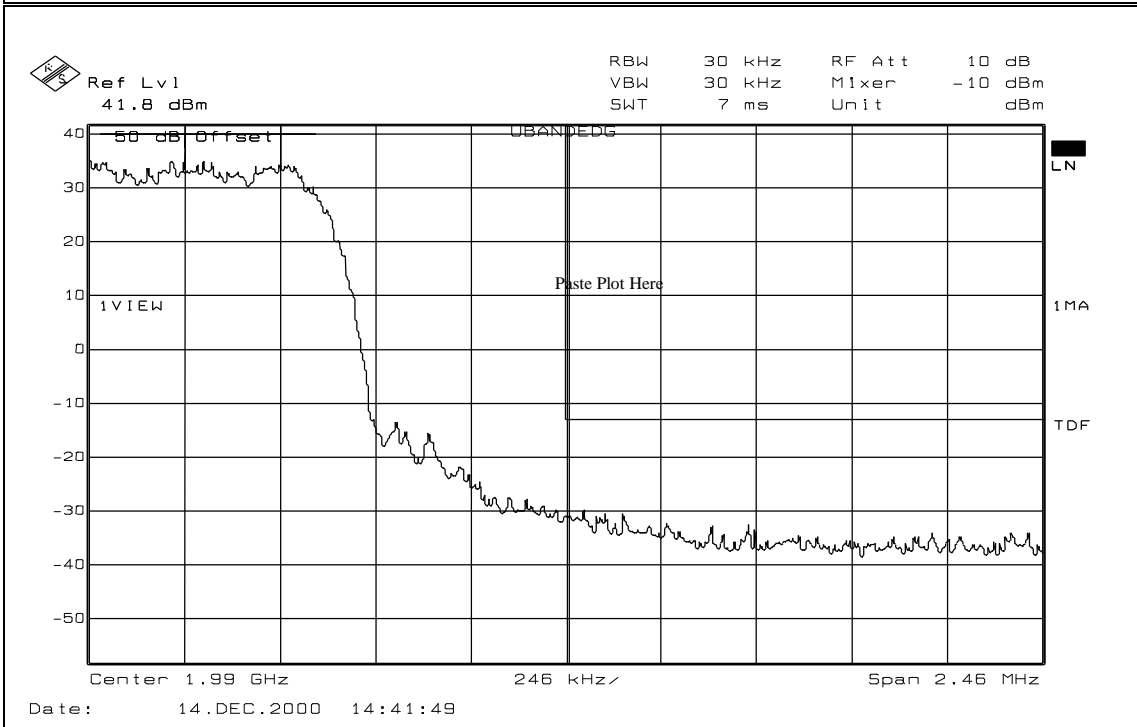

**Notes:**

---



---



---

EQUIPMENT: SCBS-419L Indoor BTS

FCC ID: NP8SCBS-419L

REPORT NO.: 0L0471RUS1

### Test Data - Spurious Emissions at Antenna Terminals

**Test Plot: INTERMODULATION CHARACTERISTICS**

Page 1 of 1

Job No.: 0L0471R Date: 12/14/00  
 Specification: PART 24 Temperature(°C): 22  
 Tested By: David Light Relative Humidity(%) 50  
 E.U.T.: INDOOR BTS  
 Configuration: TRANSMIT TWO CDMA CHANNELS - FULL POWER - C BLOCK  
 Serial Number: NONE  
 Location: SAMSUNG (IN SITU) RBW: 30 kHz  
 Detector Type: Peak VBW: 30 kHz

**Test Equipment Used**

Antenna: #N/A	Directional Coupler: #N/A
Pre-Amp: #N/A	Cable #1: #N/A
Filter: #N/A	Cable #2: #N/A
Receiver: 1036	Cable #3: #N/A
Attenuator #1: 1471	Cable #4: #N/A
Attenuator #2: #N/A	Mixer: #N/A

Additional equipment used: 1048 BIRD ATTENUATOR MODEL 1000-WA-FFN-30 (PROPERTY OF SAMSUNG)  
 Measurement Uncertainty: #N/A

---

	RBW 30 kHz	RF Att 0 dB	
	VBW 30 kHz	Mixer -10 dBm	
	SWT 54 ms	Unit dBm	

Center 1.99 GHz 1.886225 MHz / Span 18.86225 MHz

Date: 14.DEC.2000 14:52:20

**Notes:**

---

*EQUIPMENT:* SCBS-419L Indoor BTS

*FCC ID:* NP8SCBS-419L

REPORT NO.: 0L0471RUS1

---

**Section 6. Field Strength of Spurious**

NAME OF TEST: Field Strength of Spurious Emissions	PARA. NO.: 2.1051
TESTED BY: David Light	DATE: 12/20/00

**Test Results:** Complies.

**Test Data:** See attached table.

EQUIPMENT: SCBS-419L Indoor BTS

FCC ID: NP8SCBS-419L

REPORT NO.: 0L0471RUS1

Test Data – Field Strength of Spurious Emissions

<b>Field Strength of Spurious Emissions</b>											
Page 1 of 1									Complete	X	
Job No.:	0L0471R	Date:		12/20/00		Preliminary					
Specification:	Part 24	Temperature(°C):		22							
Tested By:	David Light	Relative Humidity(%)		50							
E.U.T.:	20 PCS Base Station										
Configuration:	Transmit Channel 600 - Full Power - Into 50 ohm Load										
Sample Number:	1										
Location:	AC 1	RBW:	1 MHz		Measurement						
Detector Type:	Peak	VBW:	1 MHz		Distance		3 m				
<b>Test Equipment Used</b>											
Antenna:	993	Directional Coupler:	#N/A								
Pre-Amp:	1016	Cable #1:	#N/A								
Filter:	#N/A	Cable #2:	1483								
Receiver:	1283	Cable #3:	#N/A								
Attenuator #1:	#N/A	Cable #4:	#N/A								
Attenuator #2:	#N/A	Mixer:	#N/A								
Additional equipment used:											
Measurement Uncertainty:	+/-3.6 dB										
Frequency (GHz)	Meter Reading (dBm)	Antenna Factor (dB)	Cable Loss (dB)	Pre-Amp Gain (dB)	Conversion Factor	Corrected Reading (dBuV/m)	ERP (mW)	ERP (dBm)	Polarity	Comments	
1.960	-4.2	28.5	2.7	33.3	107.0	100.7	3.52	5.5	H	Carrier	
3.920	-75.3	31.6	3.9	33.4	107.0	33.8	0.00	-61.4	H	NF=Noise Floor	
5.880	-69.1	34.4	5.2	32.0	107.0	45.5	0.00	-49.7	H	NF	
7.840	-72.1	37.8	5.8	33.4	107.0	45.1	0.00	-50.1	H	NF	
9.800	-73.5	37.2	7.1	36.1	107.0	41.7	0.00	-53.5	H	NF	
11.760	-72.4	39.6	8.0	36.6	107.0	45.6	0.00	-49.6	H	NF	
13.720	-68.9	43.0	9.4	34.2	107.0	56.3	0.00	-38.9	H	NF	
1.960	-3.3	28.5	2.7	33.3	107.0	101.6	4.34	6.4	V	Carrier	
3.920	-75.3	31.6	3.9	33.4	107.0	33.8	0.00	-61.4	V	NF	
5.880	-69.1	34.4	5.2	32.0	107.0	45.5	0.00	-49.7	V	NF	
7.840	-72.1	37.8	5.8	33.4	107.0	45.1	0.00	-50.1	V	NF	
9.800	-73.5	37.2	7.1	36.1	107.0	41.7	0.00	-53.5	V	NF	
11.760	-72.4	39.6	8.0	36.6	107.0	45.6	0.00	-49.6	V	NF	
13.720	-68.9	43.0	9.4	34.2	107.0	56.3	0.00	-38.9	V	NF	
<i>Note: The carrier level was measured for reference only. The transmitter was configured to operate full power into a 50 ohm load.</i>											
Notes: Scanned to 10th harmonic of carrier frequency											

**Photographs of Test Setup**

FRONT VIEW



**Photographs of Test Setup**

REAR VIEW



*EQUIPMENT:* SCBS-419L Indoor BTS

*FCC ID:* NP8SCBS-419L

REPORT NO.: 0L0471RUS1

---

**Section 7. Frequency Stability**

NAME OF TEST: Frequency Stability	PARA. NO.: 2.1055
TESTED BY: David Light	DATE: 12/19/00

**Test Results:** Complies

**Measurement Data:** Standard Test Frequency: 1960 MHz  
Standard Test Voltage: 26 Vdc



EQUIPMENT: SCBS-419L Indoor BTS

FCC ID: NP8SCBS-419L

REPORT NO.: 0L0471RUS1

**Test data - Frequency Stability**

**Frequency Stability**

Client: Samsung

W.O.# 0L0471R

EUT: 20 Watt Base Station

S/N: None

Date: 12/19/00

Tech: D. Light

KTL Test Equipment: Spectrum analyzer #1036

ETL Equipment: Temperature chamber controller (asset #1020) cal'd 10/13/00 - Due 10/13/01  
 Chart recorder (asset #1225) cal'd 8/30/00 due 2/3/01

Temperature	Voltage	Rho	Frequency Error
20 °C	+26 VDC (Nominal)	0.9920	-62.99 Hz
20 °C	+22.1 VDC	0.9904	-70.02 Hz
20 °C	+29.9 VDC	0.9906	-80.86
-20° C	+26 VDC	0.9893	+69.42 Hz
-10° C	+26 VDC	0.9902	-74.41 Hz
0° C	+26 VDC	0.9906	-70.8 Hz
+10° C	+26 VDC	0.9900	-106.05 Hz
+30° C	+26 VDC	0.9904	-87.4 Hz
+40° C	+26 VDC	0.9906	-80.16 Hz
+50° C	+26 VDC	0.9903	-90.8 Hz

Temperature chamber controller - Thermatron  
 Chart recorder - Eclipse Controls

EQUIPMENT: SCBS-419L Indoor BTS

FCC ID: NP8SCBS-419L

REPORT NO.: 0L0471RUS1

**Section 8. Test Equipment List**

KTL ID	Description	Manufacturer	Serial Number	Calibration
		Model Number		Date
1036	SPECTRUM ANALYZER	ROHDE & SCHWARZ FSEK30	830844/006	06/14/99 2 Yr. Cycle
1471	10 dB Attenuator	MCL Inc. BW-S10W2 10db- 2WDC	NONE	CBU
1048	50 OHM LOAD	NARDA 27470	254	02/15/00
993	Horn antenna	A.H. Systems SAS-200/571	XXX	07/16/99 2 Yr. Cycle
1016	AMPLIFIER	HEWLETT PACKARD 8449A	2749A00159	05/24/00
1283	Spectrum analyzer display	Hewlett Packard 85662A	1811A00223	10/05/00
1483	Cable 4m	Storm PR90-010-144	N/A	05/23/00
	Temperature Chamber Controller	ETL	1020	10/13/00
	Chart Recorder	ETL	1225	8/30/00
	30 dB Power Attenuator	Bird 1000-WA-FFN-30	Property of Samsung	CBU

**KTL Dallas**

FCC PART 24, SUBPART E  
BROADBAND PCS BASE STATION TRANSMITTER

*EQUIPMENT:* SCBS-419L Indoor BTS

*FCC ID:* NP8SCBS-419L

REPORT NO.: 0L0471RUS1

---

## ANNEX A - TEST DETAILS

EQUIPMENT: SCBS-419L Indoor BTS

FCC ID: NP8SCBS-419L

REPORT NO.: 0L0471RUS1

**NAME OF TEST: RF Power Output****PARA. NO.: 2.1046**

**Minimum Standard:** Para. No.24.232. Base stations are limited to 1640 watts peak E.I.R.P. with an antenna height up to 300 meters HAAT. In no case may the peak output power of a base station transmitter exceed 100 watts.

**Method Of Measurement:** CDMA Per ANSI/J-STD-014  
TDMA Per ANSI/J-STD-010

Detachable Antenna:

The peak power at antenna terminals is measured using an in-line peak power meter or a spectrum analyzer.

Integral Antenna:

If the antenna is not detachable from the circuit then the Peak Power Output is derived from the peak radiated field strength of the fundamental emission by using the plane wave relation  $GP/4\pi R^2 = E^2/120\pi$  and proceeding as follows:

$$P = \frac{E^2 R^2}{30G} = \frac{E^2 3^2}{30G}$$

where,

P = the equivalent isotropic radiated power in watts

E = the maximum measured field strength in V/m

R = the measurement range (3 meters)

G = the numeric gain of the transmit antenna in relation to an isotropic radiator

*EQUIPMENT:* SCBS-419L Indoor BTS

*FCC ID:* NP8SCBS-419L

REPORT NO.: 0L0471RUS1

---

<b>NAME OF TEST: Occupied Bandwidth</b>	<b>PARA. NO.: 2.1049</b>
---	--------------------------

**Minimum Standard:** Para. No. 24.238(b). The emission bandwidth is defined as the width of the signal between two points, one below the carrier center frequency and one above the carrier center frequency, outside of which all emissions are attenuated at least 26 dB.

**Method Of Measurement:**

CDMA Per ANSI/J-STD-014

Spectrum analyzer settings:

RBW: 30 kHz

VBW:  $\geq$  RBW

Span: 5 MHz

Sweep: Auto

GSM Per ANSI/J-STD-010

RBW: 3 kHz

VBW:  $\geq$  RBW

Span: 2 MHz

Sweep: Auto

NADC Per IS-136

RBW: 1 kHz

VBW:  $\geq$  RBW

Span: 1 MHz

Sweep: Auto

*EQUIPMENT:* SCBS-419L Indoor BTS

*FCC ID:* NP8SCBS-419L

REPORT NO.: 0L0471RUS1

**NAME OF TEST: Spurious Emission at Antenna Terminals      PARA. NO.: 2.1051**

**Minimum Standard:** Para. No.24.238(a). On any frequency outside a licensee’s frequency block, the power of any emission shall be attenuated below the transmitter power by at least 43 + 10 log (P) dB.

**Method Of Measurement:**

Spectrum analyzer settings:

CDMA Per ANSI/J-STD-014

GSM Per ANSI/J-STD-010

RBW: 1 MHz (> 1 MHz from Band Edge)

RBW: 1 MHz (> 1 MHz from Band Edge)

RBW: 30 kHz (< 1MHz from Band Edge)

RBW: 3 kHz (< 1 MHz from Band Edge)

VBW: ≥ RBW

VBW: ≥ RBW

Sweep: Auto

Sweep: Auto

Video Avg: 6 Sweeps

Video Avg: Disabled

NADC Per IS-136

RBW: 1 MHz (> 1 MHz from Band Edge)

RBW: 1 kHz (< 1 MHz from Band Edge)

VBW: ≥ RBW

Sweep: Auto

Video Avg: Disabled

To demonstrate compliance at band edges the frequency of the input signal is set to the lowest and highest assigned channel and the center frequency of the spectrum analyzer is set to the upper and lower edges of the appropriate frequency block.

EQUIPMENT: SCBS-419L Indoor BTS

FCC ID: NP8SCBS-419L

REPORT NO.: 0L0471RUS1

**NAME OF TEST: Field Strength of Spurious Radiation****PARA. NO.: 2.1053**

**Minimum Standard:** Para. No.24.238(a). On any frequency outside a licensee's frequency block, the power of any emission shall be attenuated below the transmitter power by at least  $43 + 10 \log (P)$  dB.

### Calculation Of Field Strength Limit

An example of attenuation requirement of  $43 + 10 \log P$  is equivalent to -13 dBm ( $5 \times 10^{-5}$  Watts) at the antenna terminal. We determine the field strength limit by using the plane wave relation.

$$GP/4\pi R^2 = E^2/120\pi$$

For emissions  $\leq 1$  GHz:

$G = 1.64$  (Dipole Gain)

$P = 10^{-5}$  Watts (Maximum spurious output power)

$R = 3$ m (Measurement Distance)

$$E = \frac{\sqrt{30GP}}{R}$$

$$E = \frac{\sqrt{30 \times 1.64 \times 5 \times 10^{-5}}}{3} = 0.016533 \text{ V / m} = 84.4 \text{ dBmV / m}$$

For emissions  $> 1$  GHz:

$G = 1$  (Isotropic Gain)

$P = 1 \times 10^{-5}$  Watts (Maximum spurious output power)

$R = 3$ m (Measurement Distance)

$$E = 84.4 - 20 \log \sqrt{1.64} = 82.3 \text{ dBmV / m @ 3m}$$

*EQUIPMENT:* SCBS-419L Indoor BTS

*FCC ID:* NP8SCBS-419L

REPORT NO.: 0L0471RUS1

---

<b>NAME OF TEST: Frequency Stability</b>	<b>PARA. NO.: 2.1055</b>
--	--------------------------

**Minimum Standard:** Para. No. 24.235. The frequency stability shall be sufficient to ensure that the fundamental emission stays within the authorized frequency block.

**Method Of Measurement:** CDMA Per ANSI/J-STD-014  
TDMA Per ANSI/J-STD-010  
NADC Per IS-136

Frequency Stability With Voltage Variation

The E.U.T. is placed in an environmental chamber and allowed to stabilize at +20 degrees Celsius for at least 15 minutes. With the voltage input to the E.U.T. set to 85% S.T.V., the frequency is measured in 30 second intervals for a period of 5 minutes. This procedure is repeated at 100% S.T.V. and 115% S.T.V.

Frequency Stability With Temperature Variation

The input voltage to the E.U.T. is set to S.T.V. and the temperature of the environmental chamber is varied in 10 degree steps from -30 degrees C to +50 degrees C. The E.U.T. is allowed to stabilize at each temperature and the frequency is measured in 30 second intervals for a period of 5 minutes.



*EQUIPMENT:* SCBS-419L Indoor BTS

*FCC ID:* NP8SCBS-419L

REPORT NO.: 0L0471RUS1

---

## ANNEX B - TEST DIAGRAMS

**Para. No. 2.985 - R.F. Power Output**

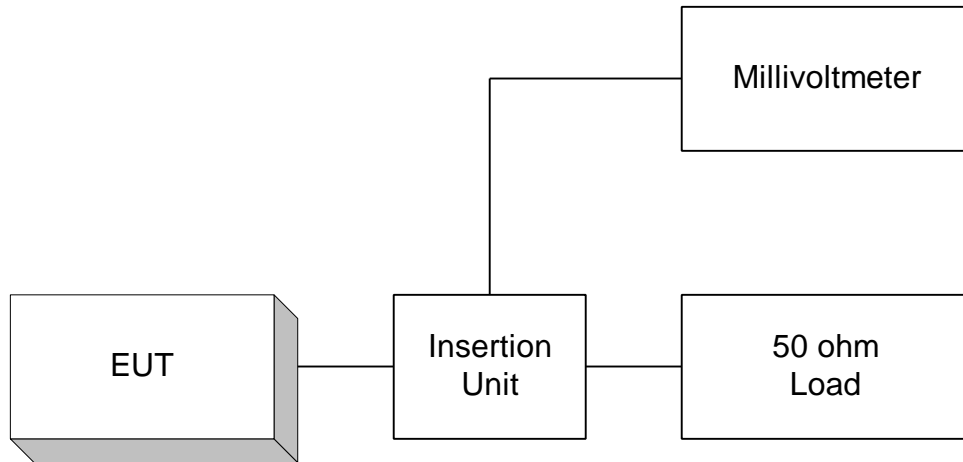

**Para. No. 2.989 - Occupied Bandwidth**

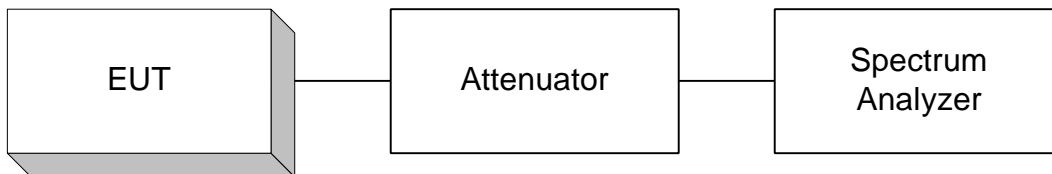

**Para. No. 2.991 Spurious Emissions at Antenna Terminals**

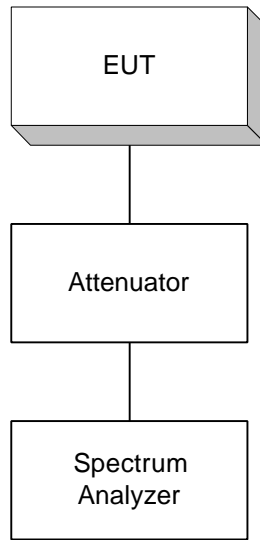

**Para. No. 2.993 - Field Strength of Spurious Radiation**

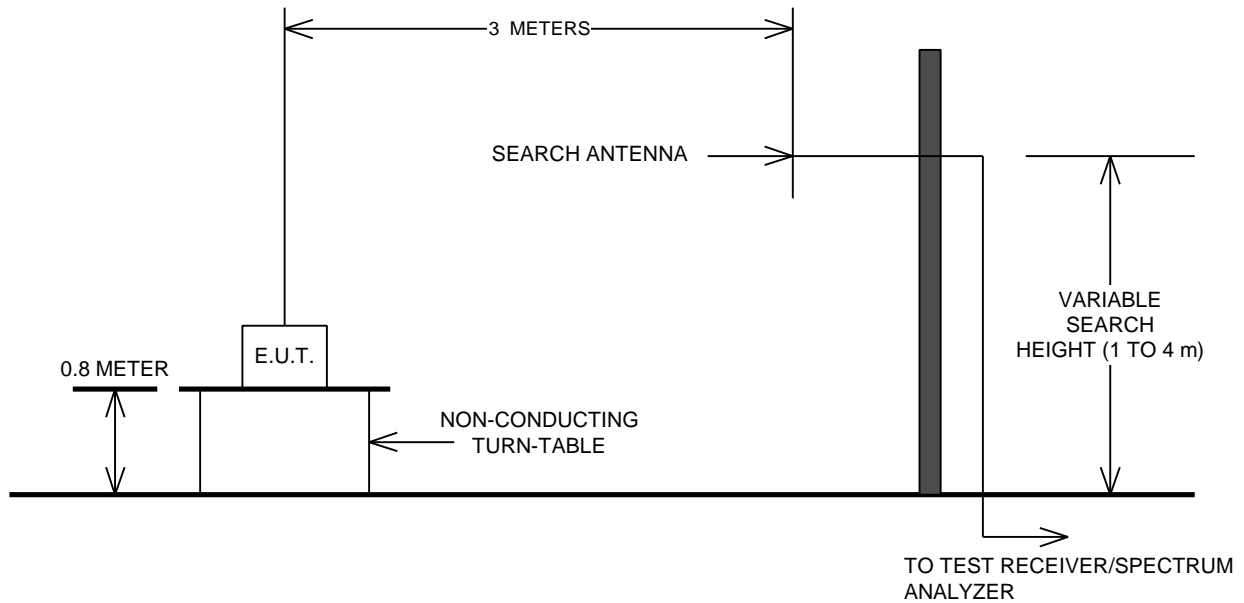

**Para. No. 2.995 - Frequency Stability**

