

CalAmp Wireless Networks Corp.
299 Johnson Avenue, Suite 110
Waseca, MN 56093-0833 USA
Phone: 507-833-8819
Fax: 507-833-6748

FCC Part 22, 24, 90 and 101 Certification Application

FCC Form 731

For The

**VIPER SC+ 900
900 MHz RADIO MODEM**

FCC ID: NP45098504

Table of Contents

1.0	Transmitter Rated Power Output	3
2.0	Transmitter Spurious and Harmonic Outputs	4
3.0	Frequency Stability with Variation in Supply Voltage	8
4.0	Frequency Stability with Variation in Ambient Temperature	9
5.0	Transmitter Occupied Bandwidth Necessary Bandwidth	11
6.0	Mask E - Part 90.210(e) – 6 kHz ABW	14
7.0	Mask D - Part 90.210(d) – 11.25 kHz ABW	21
8.0	Mask C - Part 90.210(c) – 20 kHz ABW	30
9.0	Mask J - Part 90.210(j) – 13.6 kHz ABW	39
10.0	Mask J – Part 90.210(j) Aggregation for 25 kHz Channel	54
11.0	Mask J – Part 90.210(j) Aggregation for 50 kHz Channel	63
12.0	Mask J – Part 90.210(j) Aggregation for 100 kHz Channel	72
13.0	Mask G - Part 90.210(g)– 20 kHz ABW & Mask 90.691 25 kHz Channel	82
14.0	Part 24.133(a)(2) – 10 kHz ABW	92
15.0	Part 24.133(a)(1) – 20 kHz ABW	101
16.0	Part 24.133(a)(1) – 45 kHz ABW	110
17.0	Part 24.133(a)(1) – 95 kHz ABW	119
18.0	Part 101.111(a)(5) – 12.5 kHz ABW	128
19.0	Part 101.111(a)(6) – 25 kHz ABW	137
20.0	Part 101.111(a)(6) – 50 kHz ABW	146
21.0	Part 101.111(a)(6) – 100 kHz ABW	155
22.0	Calibration Information	164

1.0 Transmitter Rated Power Output

RULE PART NUMBER: 2.1046 (a) (c), 22.535, 24.132, 101.113 (a)

TEST RESULTS: See results below

TEST CONDITIONS: Standard Test Conditions

TEST EQUIPMENT: 50-Ohm Atten, Bird Electronics Model 50-A-MFN-20 (20dB, 50W)
 50-Ohm Atten, Bird Electronics Model 10-A-MFN-10 (10dB, 10W)
 Power Supply, Hewlett Packard Model 6653A
 Digital Multimeter, HP 3478A
 Power Meter, Model HP437B

TEST SET-UP:

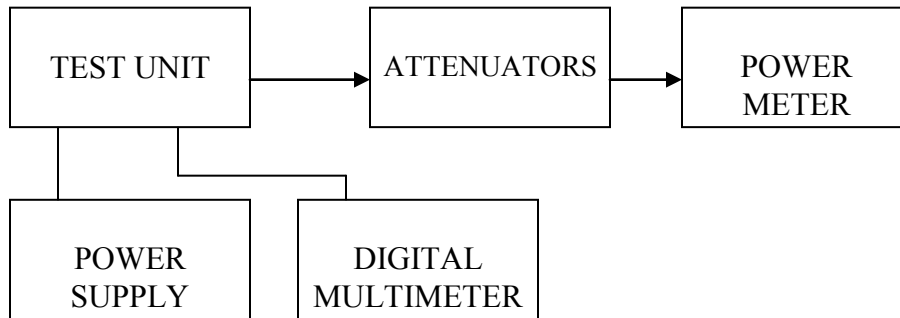

TEST RESULTS:

Frequency (MHz)	DC Voltage at Final (Vdc)	DC Current into Final (Adc)	DC Power into Final (W)	RF Power Output (W)
943.950	12.7	2.38	30.23	10.0
943.950	7.80	0.78	6.08	1.0

Part 22 Effective Radiated Power Limits:

Frequency range (MHz)	Maximum ERP (Watts)
35–36	600
43–44	500
152–159	1400
931–932	3500

2.0 Transmitter Spurious and Harmonic Outputs

RULE PART NUMBER: 2.1051, 90.210 (c,3)(d,3)(e,3), 101.111(5)(6), 24.133, 22.359;

MINIMUM STANDARDS: For 10 Watts: $55+10\text{Log}_{10}(10 \text{ Watts}) = -65 \text{ dBc}$
or -65dBc , whichever is the lesser attenuation.

For 1 Watt: $55+10\text{Log}_{10}(1 \text{ Watt}) = -55 \text{ dBc}$
or -65 dBc , whichever is the lesser attenuation.

TEST RESULTS: Meets minimum standards (see data on following pages)

TEST CONDITIONS: Standard Test Conditions, 25 C
RF Voltage measured at antenna terminals

TEST PROCEDURE: TIA/EIA – 603-C

TEST EQUIPMENT: 50-Ohm Atten, Bird Electronics Model 50-A-FFN-20 (20dB, 50W)
50-Ohm Atten, Bird Electronics Model 10-A-MFN-10 (10dB, 10W)
Power Supply, Hewlett Packard Model 6653A
Spectrum Analyzer, HP 8563E
Power Meter, Model HP437B
Reference Generator, Agilent E8257D
High Pass Filter, Mini Circuits VHP-16, $F_c = 1900 \text{ MHz}$

TEST SET-UP:

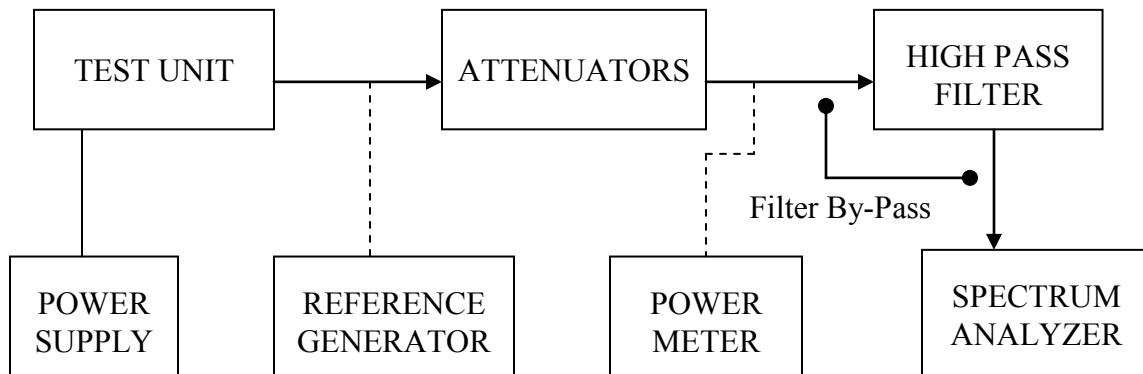

MEASUREMENT PROCEDURE:

1. The transmitter carrier output frequencies are 928.050, 943.950, and 952.950. The reference oscillator frequency is 23.04 MHz. The power amplifier has voltage levels at 14.0 Volts and 8.0 Volts for 10 watts and 1 watt, respectively.
2. The carrier reference was established on the spectrum analyzer with the filter bypass in place. Then the spectrum was scanned from DC to $2 F_c$. Finally, the high pass filter was inserted to null the carrier fundamental and extend the range of the spectrum analyzer for harmonic measurements above $2 F_c$.
3. At each spurious frequency, generation substitution was used to establish the true spurious level.
4. The spectrum was scanned to the 10th harmonic of the highest internally generated frequency.

Tuned Frequency	928.050 MHz		Tuned Frequency	928.050 MHz	
Power (Watts)	10.0 Watts		Power (Watts)	1.00 Watt	
Power (dBm)	+40 dBm		Power (dBm)	+30 dBm	
Spec Limit	-65 dBc		Spec Limit	-55 dBc	
Worse Case			Worse Case		
Spurious	Relation to the Carrier	Relative to the Carrier	Spurious	Relation to the Carrier	Relative to the Carrier
Frequency (MHz)			Frequency (MHz)		
1856.100	2Fo	-110.00	1856.100	2Fo	-103.00
2784.150	3Fo	-93.00	2784.150	3Fo	-111.00
3712.200	4Fo	-110.00	3712.200	4Fo	-99.00
4640.250	5Fo	-99.00	4640.250	5Fo	-102.00
5568.300	6Fo	-111.00	5568.300	6Fo	-96.00
6496.350	7Fo	-100.00	6496.350	7Fo	-97.00
7424.400	8Fo	-105.00	7424.400	8Fo	-93.00
8352.450	9Fo	-93.00	8352.450	9Fo	-100.00
9280.500	10Fo	-114.00	9280.500	10Fo	-100.00

Tuned Frequency	943.950 MHz		Tuned Frequency	943.950 MHz	
Power (Watts)	10.0 Watts		Power (Watts)	1.00 Watt	
Power (dBm)	+40 dBm		Power (dBm)	+30 dBm	
Spec Limit	-65 dBc		Spec Limit	-55 dBc	
Worse Case			Worse Case		
Spurious	Relation to the Carrier	Relative to the Carrier	Spurious	Relation to the Carrier	Relative to the Carrier
Frequency (MHz)			Frequency (MHz)		
1886.100	2Fo	-107.00	1886.100	2Fo	-106.00
2829.150	3Fo	-112.00	2829.150	3Fo	-114.00
3772.200	4Fo	-115.00	3772.200	4Fo	-106.00
4715.250	5Fo	-94.00	4715.250	5Fo	-106.00
5658.300	6Fo	-93.00	5658.300	6Fo	-105.00
6601.350	7Fo	-107.00	6601.350	7Fo	-105.00
7544.400	8Fo	-106.00	7544.400	8Fo	-100.00
8487.450	9Fo	-106.00	8487.450	9Fo	-101.00
9430.500	10Fo	-114.00	9430.500	10Fo	-102.00

Tuned Frequency	959.950 MHz		Tuned Frequency	959.950 MHz	
Power (Watts)	10.0 Watts		Power (Watts)	1.00 Watt	
Power (dBm)	+40 dBm		Power (dBm)	+30 dBm	
Spec Limit	-65 dBc		Spec Limit	-55 dBc	
Worse Case			Worse Case		
Spurious	Relation to the Carrier	Relative to the Carrier	Spurious	Relation to the Carrier	Relative to the Carrier
Frequency (MHz)			Frequency (MHz)		
1919.900	2Fo	-110.00	1919.900	2Fo	-110.00
2879.850	3Fo	-104.00	2879.850	3Fo	-107.00
3839.800	4Fo	-110.00	3839.800	4Fo	-113.00
4799.750	5Fo	-88.00	4799.750	5Fo	-92.00
5759.700	6Fo	-98.00	5759.700	6Fo	-102.00
6719.650	7Fo	-103.00	6719.650	7Fo	-105.00
7679.600	8Fo	-107.00	7679.600	8Fo	-102.00
8639.550	9Fo	-100.00	8639.550	9Fo	-97.00
9599.500	10Fo	-91.00	9599.500	10Fo	-93.00

3.0 Frequency Stability with Variation in Supply Voltage

RULE PART NUMBER: 2.1055 (d)(1), 90.213 (a), 101.107, 24.135, 22.355;

MINIMUM STANDARD: Shall not exceed ± 0.50 ppm.

TEST RESULTS: Meets minimum standard, see data on following page

TEST CONDITIONS: Standard Test Conditions, 25 C 13.6Vdc Nominal

TEST EQUIPMENT: Frequency Counter, HP 8901A Modulation Analyzer
 DC Power Supply, Hewlett Packard Model 6653A
 Digital Voltmeter, HP 3478A DMM
 50-Ohm Attenuator, Bird Electronics Model 50-A-FFN-20 (20dB, 50W)
 50-Ohm Attenuator, Bird Electronics Model 10-A-MFN-10 (10dB, 10W)

TEST SET-UP:

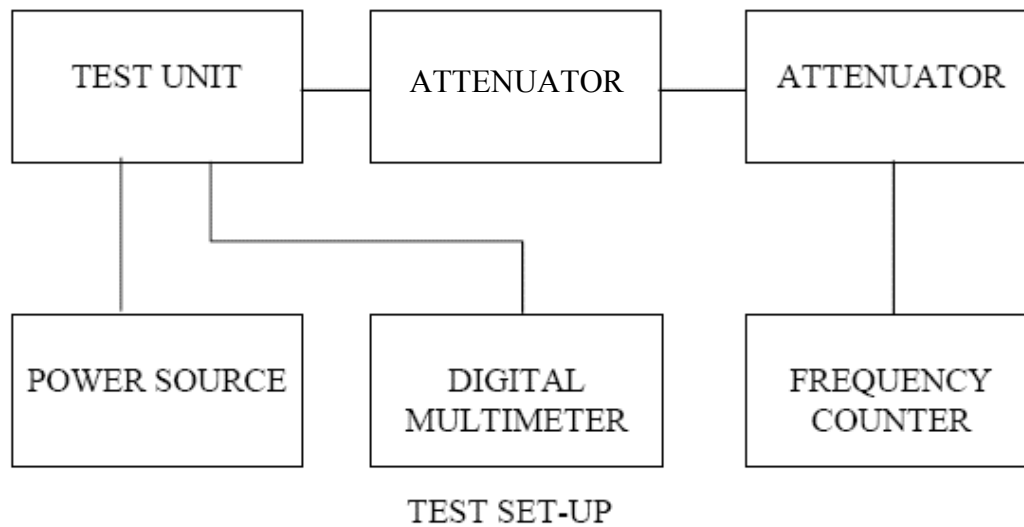

Channel Frequency: 943.950 MHz
 Tolerance Requirements: ± 0.50 ppm
 Highest Variation: ppm
 Power Output: 10 Watts

Input Voltage (Vdc)	Frequency (MHz)	Frequency Error (Hz)	Frequency Error (ppm)
10.0	943.950000	0.00	0.00
13.6 Nominal	943.950000	0.00	0.00
30.0	943.950000	0.00	0.00

4.0 Frequency Stability with Variation in Ambient Temperature

RULE PART NUMBER: 2.1055 (d)(1), 90.213 (a), 101.107, 24.135, 22.355

MINIMUM STANDARD: Shall not exceed ± 0.50 ppm from test frequency

TEST RESULTS: Meets minimum standard, see data on following page

TEST CONDITIONS: Standard Test Conditions

TEST EQUIPMENT: Frequency Counter, HP 8901A Modulation Analyzer
 DC Power Supply, Hewlett Packard Model 6653A
 Digital Voltmeter, HP 3478A DMM
 50-Ohm Attenuator, Bird Electronics Model 50-A-FFN-20 (20dB, 50W)
 50-Ohm Attenuator, Bird Electronics Model 10-A-MFN-10 (10dB, 10W)
 Climate Chamber, Tenney Jr.

TEST SET-UP:

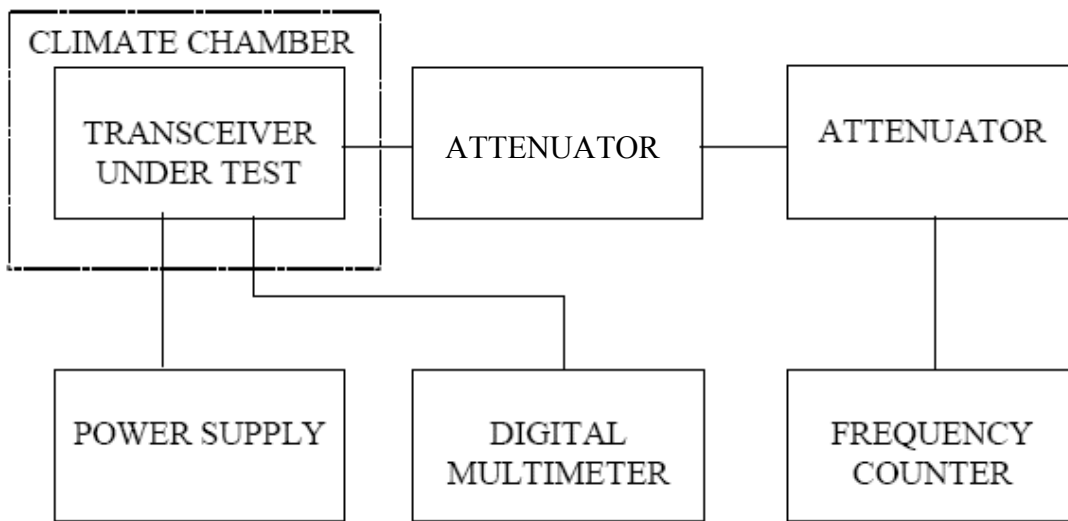

Channel Frequency: 943.950000 MHz
 Voltage & Power Level: 13.6V Nominal @ 10 Watts
 Highest Variation: -0.41 ppm

Temperature (Deg C)	Measured Frequency (MHz)	Frequency Error (Hz)	Frequency Error (ppm)
-30	943.949620	-390	-0.41
-20	943.949650	-360	-0.38
-10	943.949730	-280	-0.30
0	943.949910	-100	-0.11
10	943.949930	-80	-0.08
20	943.949990	-20	-0.02
25	943.950010	0	0.00
30	943.950020	10	0.01
40	943.949970	-40	-0.04
50	943.949950	-60	-0.06
60	943.949870	-140	-0.15

Channel Frequency: 943.950000 MHz
 Voltage & Power Level: 13.6V Nominal @ 1 Watts
 Highest Variation: -0.41 ppm

Temperature (Deg C)	Measured Frequency (MHz)	Frequency Error (Hz)	Frequency Error (ppm)
-30	943.949620	-390	-0.41
-20	943.949650	-360	-0.38
-10	943.949720	-290	-0.31
0	943.949970	-40	-0.04
10	943.949940	-70	-0.07
20	943.949990	-20	-0.02
25	943.950010	0	0.00
30	943.950020	10	0.01
40	943.949970	-40	-0.04
50	943.949950	-60	-0.06
60	943.949870	-140	-0.15

5.0 Transmitter Occupied Bandwidth Necessary Bandwidth

RULE PART NUMBER: FCC: 2.201, 2.202, 2.1033 (c)(14), 2.1049 (h), 2.1041, 90.209, 24.131, 101.109, 22.359;

Necessary Bandwidth Measurement

This radio modem uses digital modulation signals, passing through a Squared Root Raised Cosine $\alpha=0.2$ or $\alpha=0.5$ DSP implemented low-pass filter to an FM transceiver. The digital modulation is based on SRRC4FSK allows a SRRC2FSK subset to be used for lower bit rate with a better sensitivity reception. The necessary bandwidth calculation for this type of modulation is not covered by paragraphs (1), (2) or (3) from 2.202(c). Therefore, the approach outlined in (2.202(c)(4)) is applicable in this case.

The measurement explanations are provided below.

Necessary Bandwidth Measurement:

Channel Spacing	Emission Type	Data Rate	Baud Rate	Measured Peak Deviation	Measured 99% Occupied BW
6.25 kHz	3K30 F1D	4 kbps	4000	1.15 kHz	3.30 kHz
6.25 kHz	3K55 F1D	8 kbps	4000	1.09 kHz	3.55 kHz
6.25 kHz	3K20 F1D	12 kbps	4000	1.15 kHz	3.20 kHz
12.5 kHz	8K20 F1D	8 kbps	8000	3.05 kHz	8.20 kHz
12.5 kHz	8K30 F1D	16 kbps	8000	3.70 kHz	8.30 kHz
12.5 kHz	8K50 F1D	24 kbps	8000	3.725 kHz	8.50 kHz
12.5 kHz	8K08 F1D	32 kbps	8000	3.728 kHz	8.08 kHz
25 kHz	16K5 F1D	16 kbps	16000	6.3 kHz	16.5 kHz
25 kHz	16K8 F1D	32 kbps	16000	6.3 kHz	16.8 kHz
25 kHz	17K8 F1D	48 kbps	16000	7.590 kHz	17.8 kHz
25 kHz	17K0 F1D	64 kbps	16000	7.520 kHz	17.0 kHz
50 kHz	29K8 F1D	32 kbps	32000	9.36 kHz	29.8 kHz
50 kHz	30K0 F1D	64 kbps	32000	11.02 kHz	30.0 kHz
50 kHz	29K5 F1D	96 kbps	32000	10.81 kHz	29.5 kHz
50 kHz	30K5 F1D	128 kbps	32000	11.66 kHz	30.5 kHz
100 kHz	51K0F1D	64 kbps	64000	10.18 kHz	51.0 kHz
100 kHz	52K7F1D	128 kbps	64000	12.40 kHz	52.7 kHz
100 kHz	49K7F1D	192 kbps	64000	13.02 kHz	49.7 kHz
100 kHz	51K3F1D	256 kbps	64000	13.77 kHz	51.3 kHz

THEORY OF MEASUREMENT

The way to define the Occupied Bandwidth is “the frequency bandwidth such that, below its lower and above its upper frequency limits, the mean powers radiated are each equal to 0.5 percent of the total mean power radiated by a given emission” (FCC 2.202), the mathematics are as follows:

$$0.005*TP=P_{(f_1)}=\int_0^{f_1} PSD_{(f)}df$$

$$0.995*TP=P_{(f_2)}=\int_0^{f_2} PSD_{(f)}df$$

$$OBW=f2-f1$$

where TP (total mean power) is

$$TP= \int_0^{+\infty} PSD(f)df = (1/t) \int_{-\infty}^{+\infty} |z(t)|^2 dt$$

and PSD (power spectral distribution) is

$$PSD(f)=|Z(f)|^2+|Z(-f)|^2 \quad 0 \leq f < \infty$$

and expresses the positive frequency representation of the transmitter output power for z(t) signal.

By applying these mathematics to the measurements, it is possible to measure the Occupied Bandwidth using a digital spectrum analyzer.

The Occupied Bandwidth measurement is in two parts relatively independent of each other. The first gives the RF spectrum profile, and the second calculates the frequency limits and they result in the Occupied bandwidth. While the first involves RF measurement instrumentation, the second is strictly a computational part related to measured trace.

TEST EQUIPMENT:

- 50-Ohm Attenuator, Bird Electronics Model 50-A-FFN-20 (20dB, 50W)
- 50-Ohm Attenuator, Bird Electronics Model 10-A-MFN-10 (10dB, 10W)
- DC Power Supply, Hewlett Packard Model 6653A
- Spectrum Analyzer, Hewlett Packard Model HP8563E
- Modulation Analyzer, Hewlett Packard Model HP8901A

TEST SET-UP:

For the above requirements, the occupied bandwidth of a transmitter was measured using an HP8563E using the following settings:
 Occupied BW % Power: 99%
 Trace: Max Hold A
 RBW: 100 Hz (6.25 and 12.5 kHz channels)
 RBW: 300 Hz (25 kHz and 50 kHz channels)
 VBW: 3 kHz
 SPAN: 100 kHz (6.25 and 12.5 kHz channels)
 SPAN: 150 kHz (25 kHz channels)
 SPAN: 200 kHz (50 kHz channels)

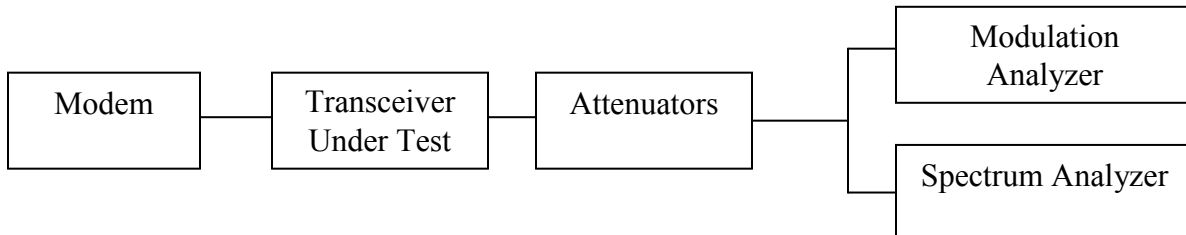

MODULATION SOURCE DESCRIPTION:

The 4-level signaling transmits two information bits per symbol (baud), which yields a bit rate of twice the on-air baud rate. Hence the 64 kbps references in the Installation Guide correspond to a transmitter baud rate of 32000 baud. The 8-level signaling transmits three information bits per symbol (baud), which yields a bit rate of three times the on-air baud rate. Hence the 12, 24, 48, or 96 kbps references in the Installation Guide correspond to a transmitter baud rate of 4000,

8000, 16000 or 32000 baud. The 16-level signaling transmits four information bits per symbol (baud), which yields a bit rate of four times the on-air baud rate. Hence the 16, 32, 64, or 128 kbps references in the Installation Guide correspond to a transmitter baud rate of 4000, 8000, 16000 or 32000baud. That digital signal is digitally filtered (Square Root Raised Cosine pulse shaping with $\alpha=0.2$ or 0.5) by the DSP and converted to I&Q components, then fed to the digital to analog converter. This SRRC4FSK, SRRC8FSK, or SRRC16FSK wave shape applied to the FM modulator will then produce a compact RF spectrum, when using proper frequency deviation, to fit inside the restrictive masks inherent to the intended channel bandwidth.

TX Data Test Pattern:

The transmit "test data" pattern command produces a 107,3741,823 bit pseudo- random pattern. This pattern is generated by the DSP. The 107,3741,823 bit sequence is repeated thereafter as long is necessary to complete the test duration, this sequence lasts 67,109 seconds at 16 kbps. Commonly this is longer than the test duration. This pattern is applied to the DSP modulator for mapping to 4-FSK, 8-FSK and 16-FSK and pulse shaping with SRRC $\alpha=0.2$ or $\alpha=0.5$ depending on the channel selection. This data follows same modulation process as described in MODULATION SOURCE DESCRIPTION and the resulting base band signal feeds the modulator's input of the transceiver.

6.0 Mask E - Part 90.210(e) – 6 kHz ABW

NAME OF TEST: Transmitter Occupied Bandwidth for Emission Designators
3K30F1D, 3K55F1D, and 3K20F1D

RULE PART NUMBER: FCC: 2.202, 90.209 (b)(5), 90.210(e), 2.1049 (c) (1)

MINIMUM STANDARDS: **Mask E**
Sidebands and Spurious [P = 10 Watts and P=1 Watt]
Authorized Bandwidth = 6 kHz
From Fo to 3 kHz, down 0 dB.
Greater than 3 kHz to 4.6 kHz, down 30 +16.67(fd-3 kHz) dB or 55 +10 log(P) or 65 dB, whichever is the lesser attenuation.
Greater than 4.6 kHz, at least 55+10log₁₀(P) or 65 dB, whichever is the lesser attenuation.

Attenuation = 0 dB at Fo to 3 kHz
Attenuation = 30 dB at 3 kHz
Attenuation = 56.7 dB at 4.6 kHz @ 10 Watts
Attenuation = 50 dB at 4.2 kHz @1 Watt
Attenuation = 55 dB at 4.6 kHz @1 Watt
Attenuation = 65 dB at frequencies greater than 4.6 kHz @ 10 Watts
Attenuation = 55 dB at frequencies greater than 4.6 kHz @ 1 Watt

TEST RESULTS: Meets minimum standards (see data on following page)

TEST CONDITIONS: Standard Test Conditions, 25 C
RF Power Level = 1 Watt and 10 Watts
Voltage = 20VDC

TEST PROCEDURE: TIA/EIA – 603-C

TEST EQUIPMENT: 50-Ohm Attenuator, Bird Electronics Model 50-A-FFN-20 (20dB, 50W)
50-Ohm Attenuator, Bird Electronics Model 10-A-MFN-10 (10dB, 10W)
50-Ohm Attenuator, Pasternack Model PE7002-10 (10dB)
DC Power Supply, Hewlett Packard Model 6653A
Spectrum Analyzer, Hewlett Packard Model HP8563E
Modulation Analyzer, Hewlett Packard Model HP8901A

TEST SET-UP:

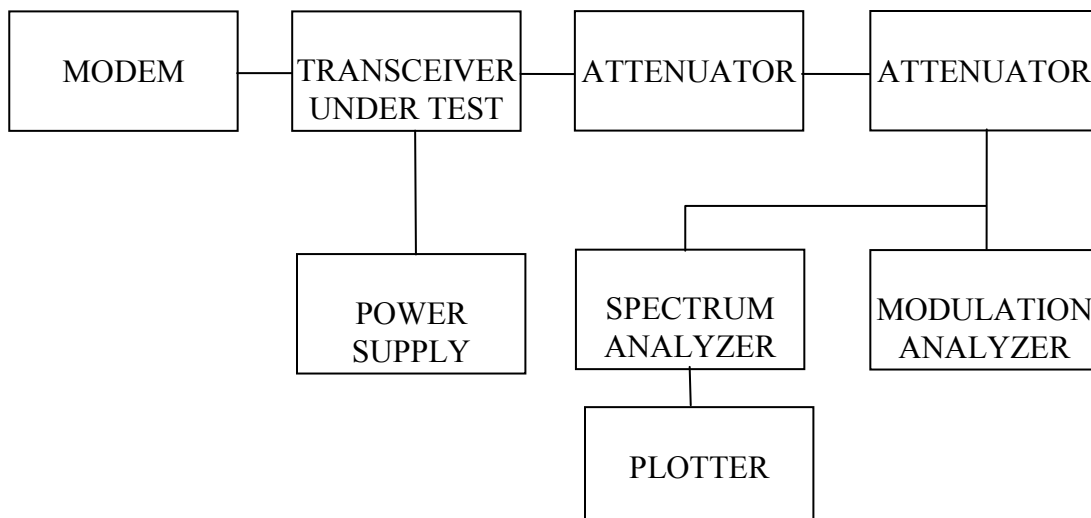

MASK E – 1.0 Watts
RF Frequency 928.050 MHz
SPECTRUM FOR EMISSION - 3K30F1D
Data Rate = 4 kbps
PEAK DEVIATION = 1.15 kHz

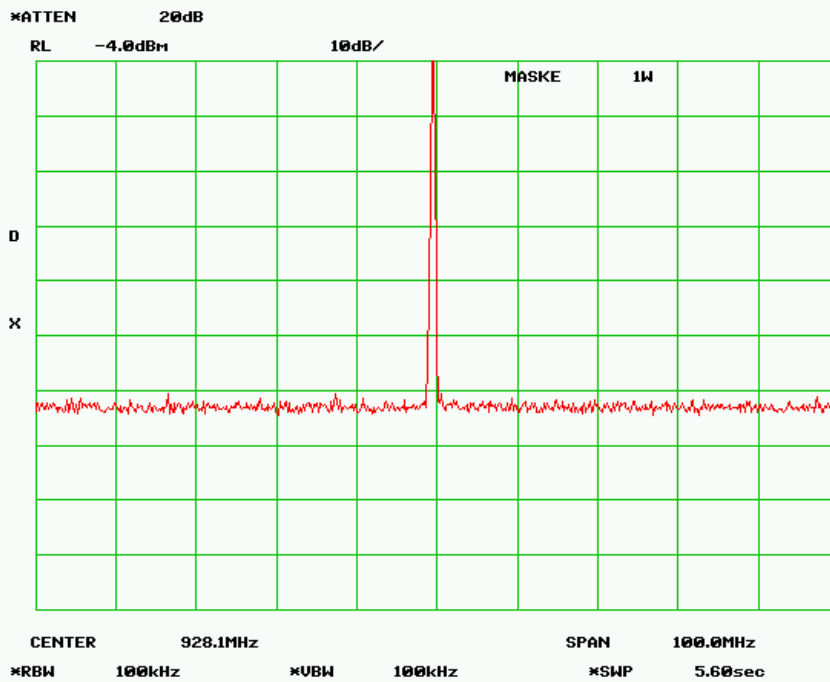
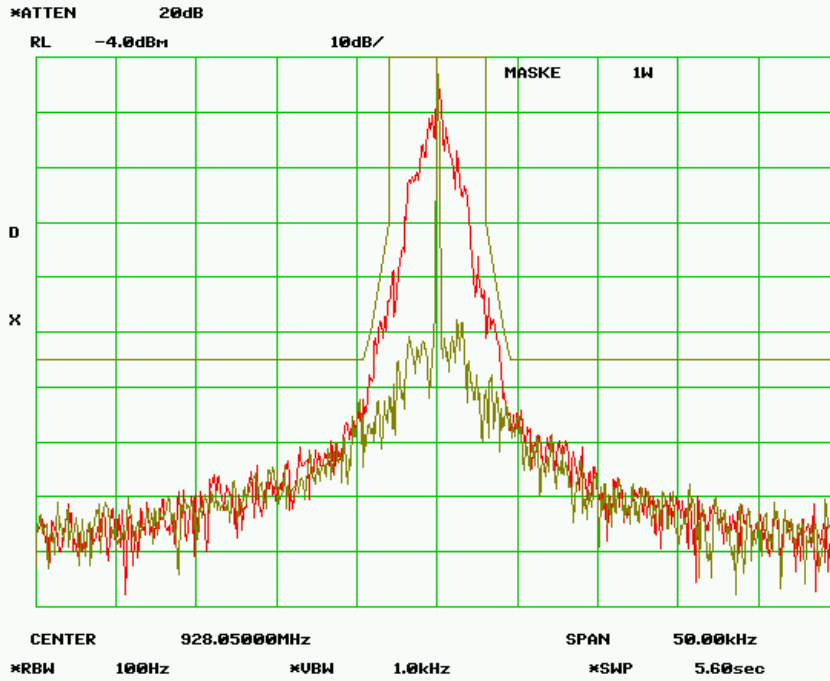

MASK E – 10.0 Watts
RF Frequency 928.050 MHz
SPECTRUM FOR EMISSION - 3K30F1D
Data Rate = 4 kbps
PEAK DEVIATION = 1.15 kHz

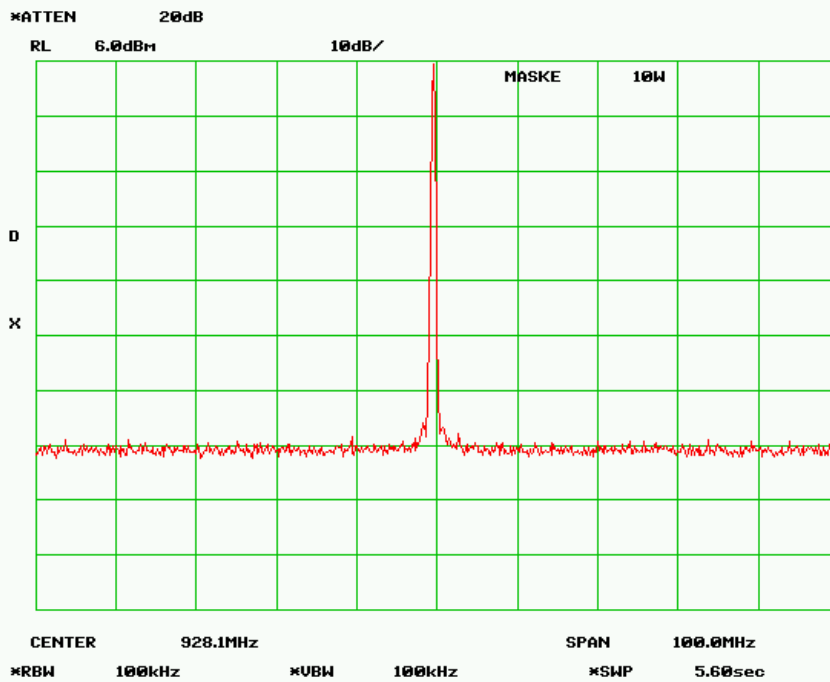
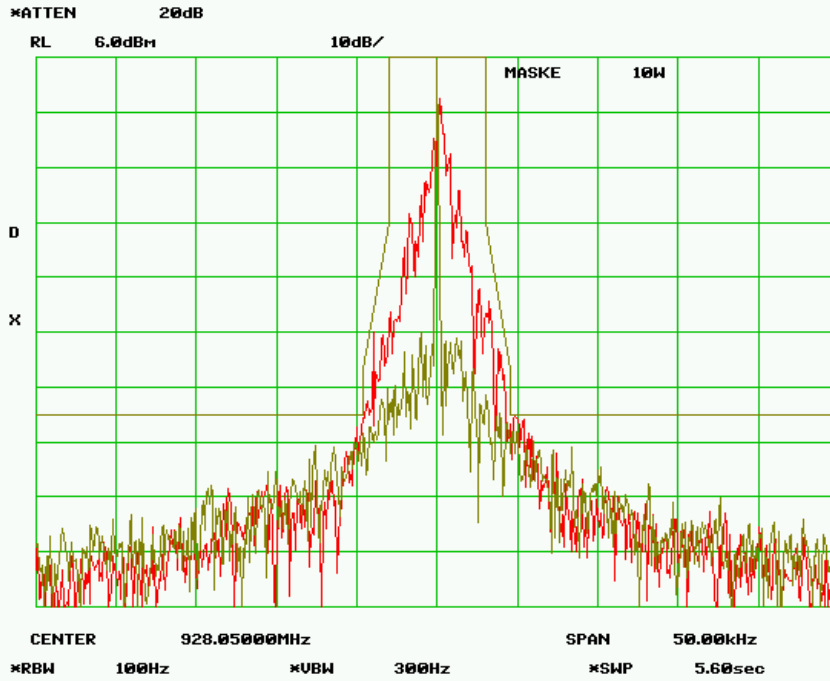

MASK E – 1.0 Watts
RF Frequency 928.050 MHz
SPECTRUM FOR EMISSION - 3K55F1D
Data Rate = 8 kbps
PEAK DEVIATION = 1.09 kHz

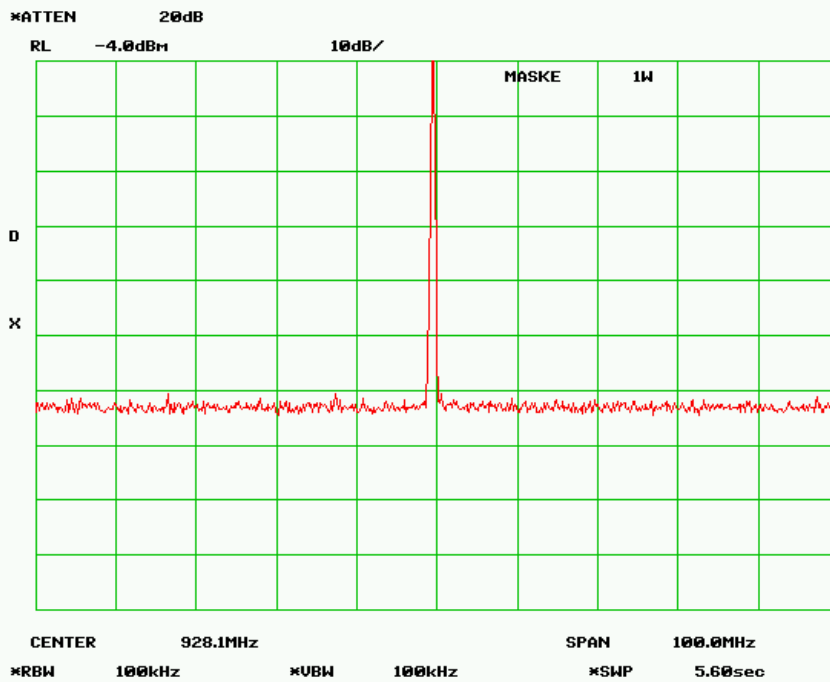
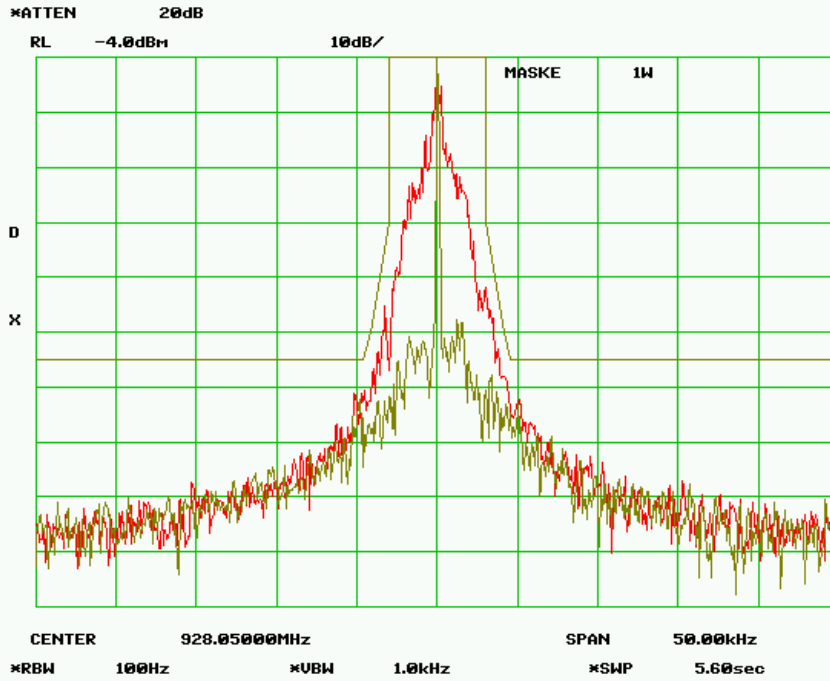

MASK E – 10.0 Watts
RF Frequency 928.050 MHz
SPECTRUM FOR EMISSION - 3K55F1D
Data Rate = 8 kbps
PEAK DEVIATION = 1.09 kHz

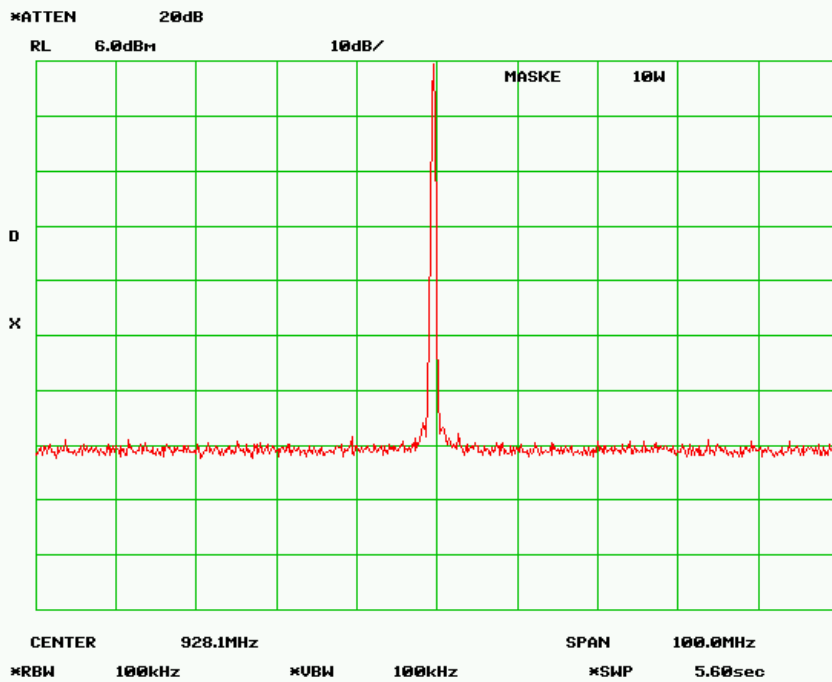
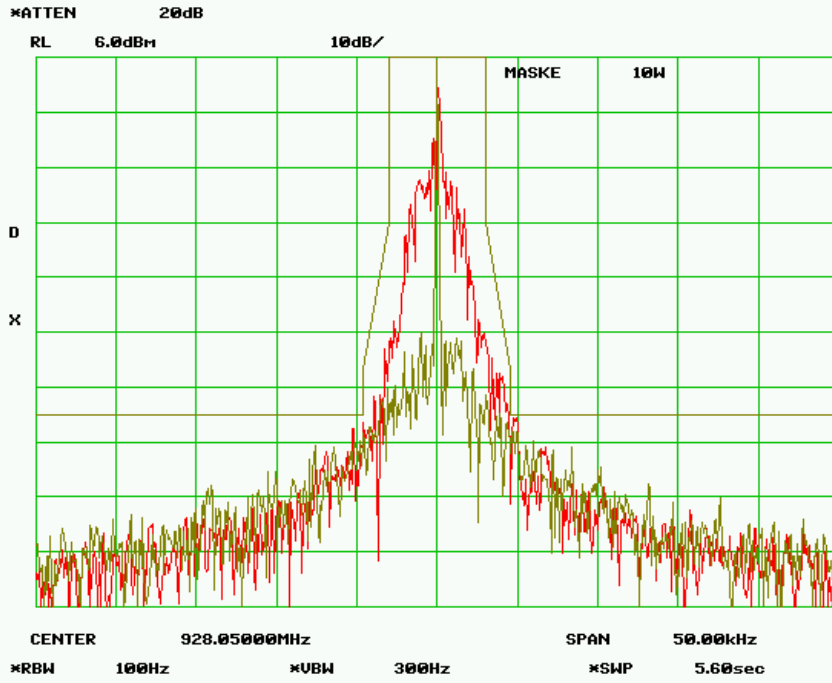

MASK E – 1.0 Watts
RF Frequency 928.050 MHz
SPECTRUM FOR EMISSION - 3K20F1D
Data Rate = 12 kbps
PEAK DEVIATION = 1.15 kHz

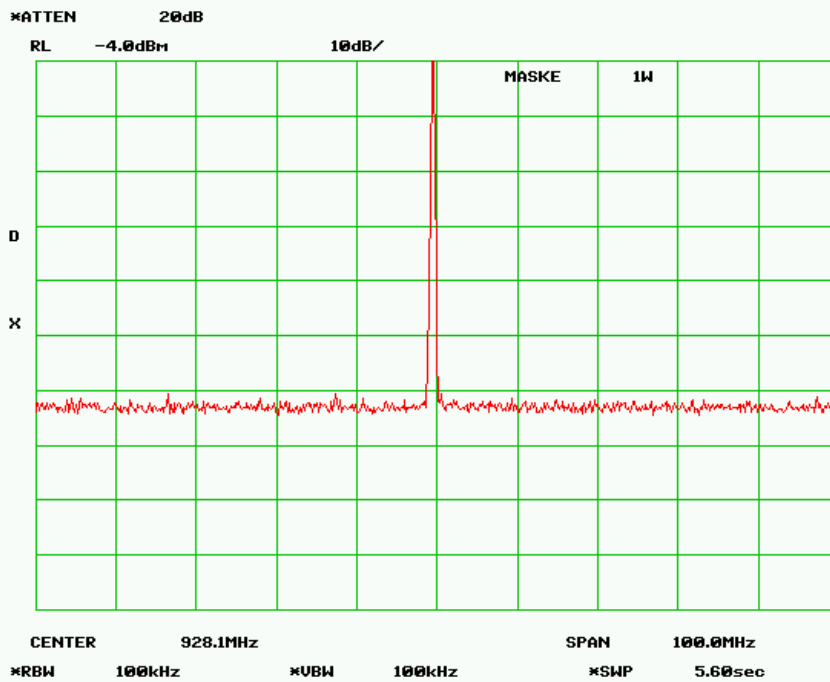
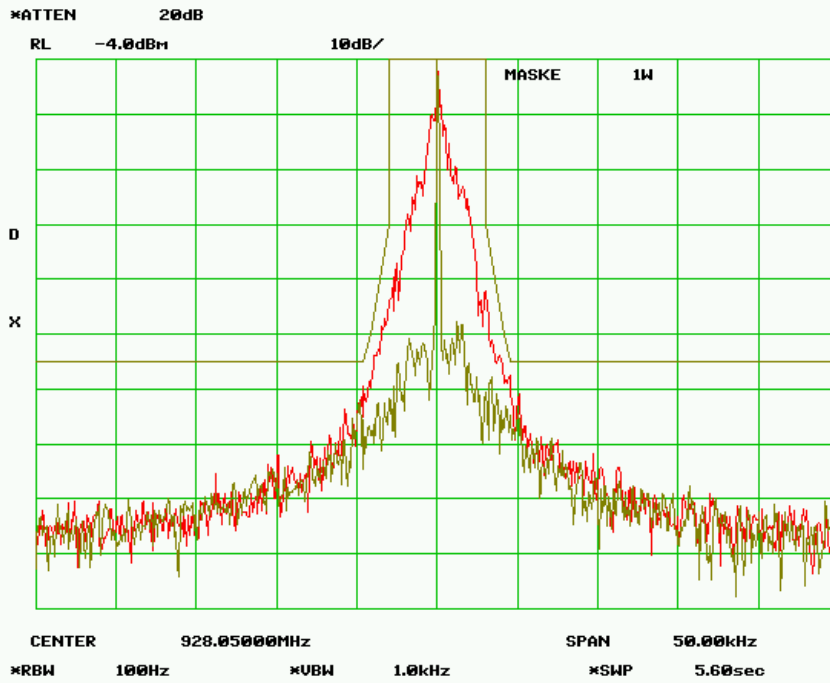

MASK E – 10.0 Watts
RF Frequency 928.050 MHz
SPECTRUM FOR EMISSION - 3K20F1D
Data Rate = 12 kbps
PEAK DEVIATION = 1.15 kHz

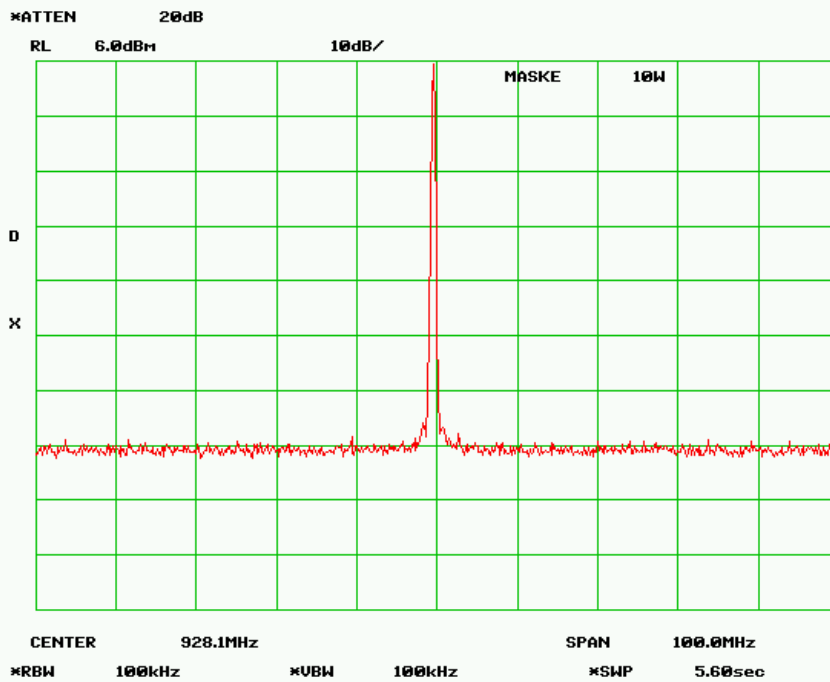
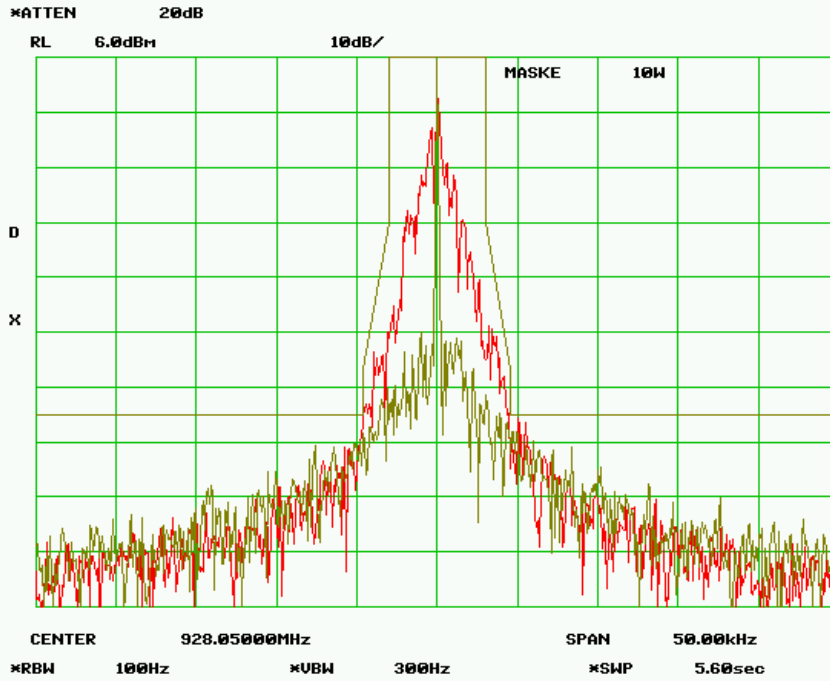

7.0 Mask D - Part 90.210(d) – 11.25 kHz ABW

NAME OF TEST: Transmitter Occupied Bandwidth for Emission Designators
8K20F1D, 8K30F1D, 8K50F1D and 8K08F1D

RULE PART NUMBER: FCC: 2.202, 90.209 (b)(5), 90.210(d), 2.1049 (c) (1)

MINIMUM STANDARDS: **Mask D**
Sidebands and Spurious [Rule 90.210 (d), P =10 Watts and P=1 Watt
Authorized Bandwidth = 11.25 kHz [Rule 90.209(b) (5)]
From Fo to 5.625 kHz ,down 0 dB.
Greater than 5.625 kHz to 12.5 kHz, down 7.27($f_i-2.88\text{kHz}$) dB.
Greater than 12.5 kHz, at least $50+10\log_{10}(P)$ or 70 dB, whichever is the lesser
attenuation.

Attenuation = 0 dB at Fo to 5.625 kHz
Attenuation = 20 dB at 5.625 kHz
Attenuation = 70 dB at 12.5 kHz
Attenuation = 60 dB at frequencies greater than 12.5 kHz @ 10 W
Attenuation = 50 dB at frequencies greater than 12.5 kHz @ 1 W

TEST RESULTS: Meets minimum standards (see data on following page)

TEST CONDITIONS: Standard Test Conditions, 25 C
RF Power Level = 1 Watt and 10 Watts
Voltage = 20VDC

TEST PROCEDURE: TIA/EIA – 603-C, 2.2.13, 3.2.11.2

TEST EQUIPMENT: 50-Ohm Attenuator, Bird Electronics Model 50-A-FFN-20 (20dB, 50W)
50-Ohm Attenuator, Bird Electronics Model 10-A-MFN-10 (10dB, 10W)
50-Ohm Attenuator, Pasternack Model PE7002-10 (10dB)
DC Power Supply, Hewlett Packard Model 6653A
Spectrum Analyzer, Hewlett Packard Model HP8563E
Modulation Analyzer, Hewlett Packard Model HP8901A

TEST SET-UP:

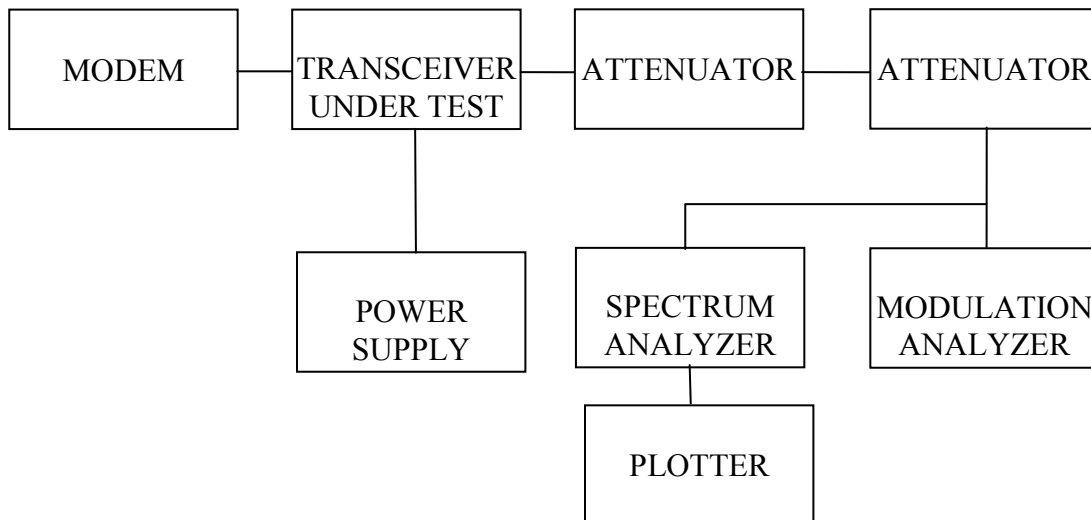

MASK D – 1.0 Watts
RF Frequency 928.050 MHz
SPECTRUM FOR EMISSION - 8K20F1D
Data Rate = 8 kbps
PEAK DEVIATION = 3.05 kHz

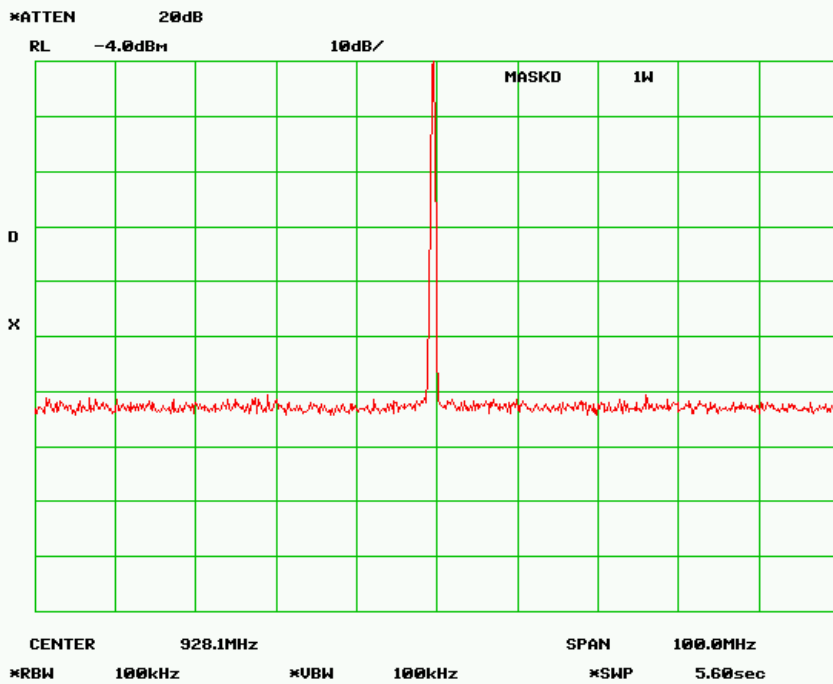
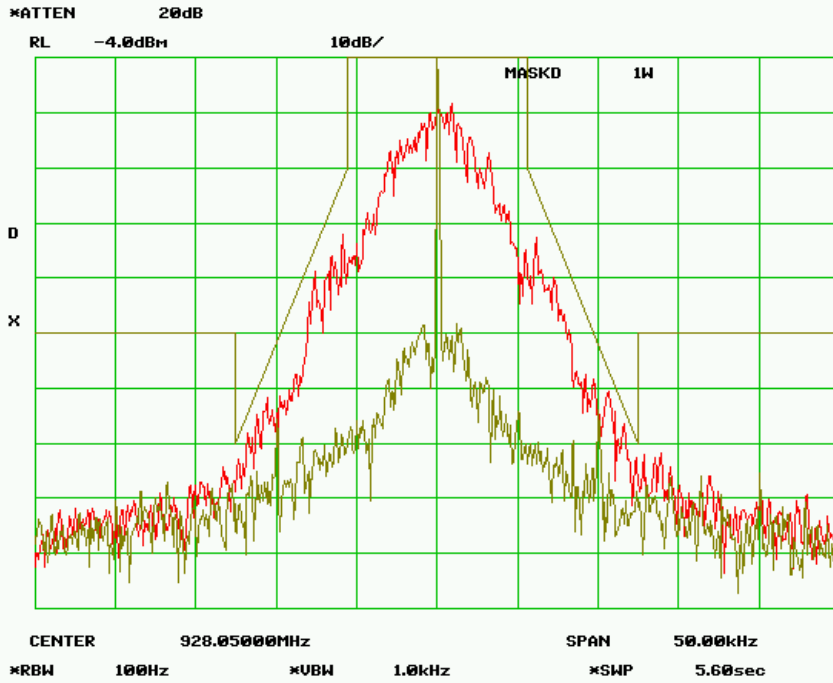

MASK D – 10.0 Watts
RF Frequency 928.050 MHz
SPECTRUM FOR EMISSION - 8K20F1D
Data Rate = 8 kbps
PEAK DEVIATION = 3.05 kHz

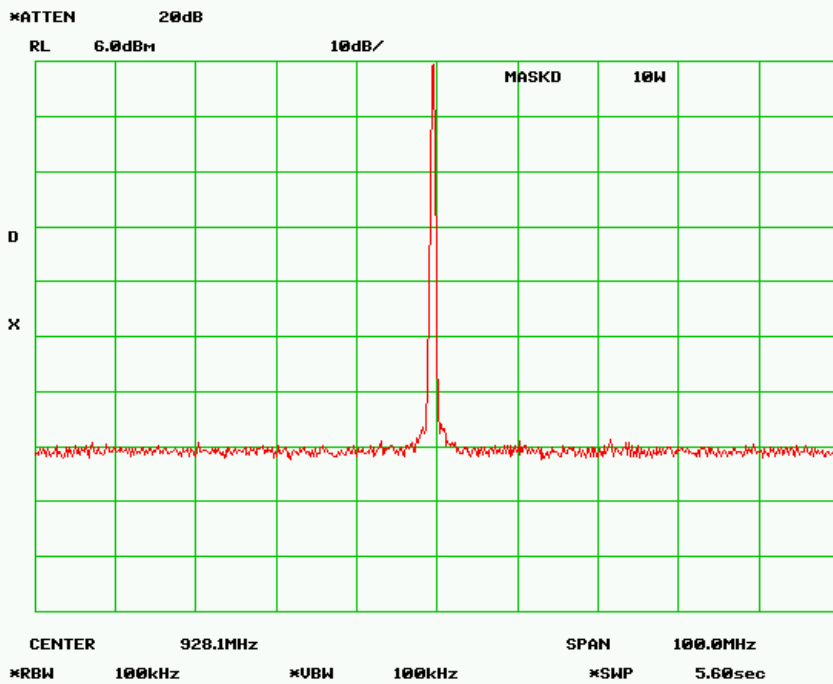
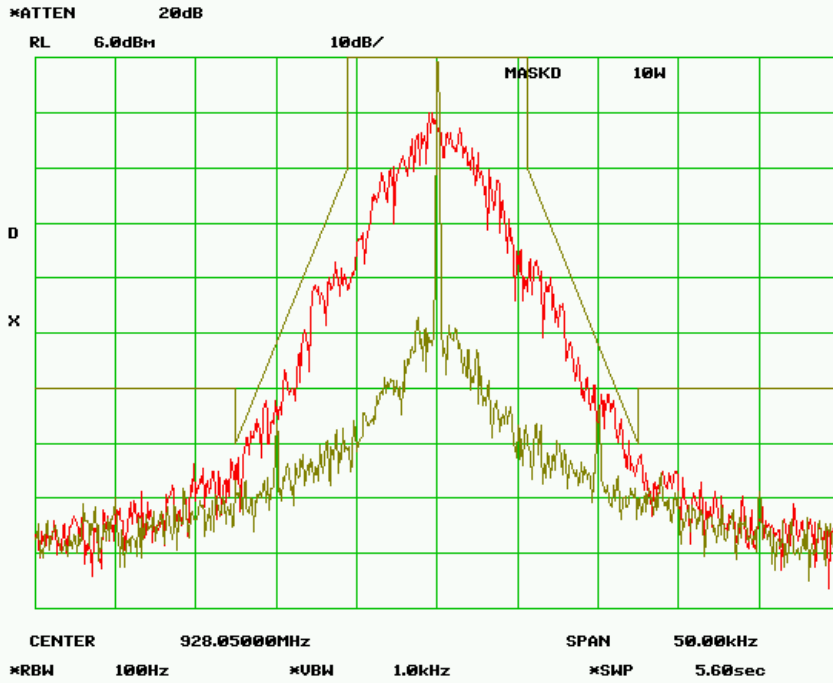

MASK D – 1.0 Watts
RF Frequency 928.050 MHz
SPECTRUM FOR EMISSION - 8K30F1D
Data Rate = 16 kbps
PEAK DEVIATION = 3.70 kHz

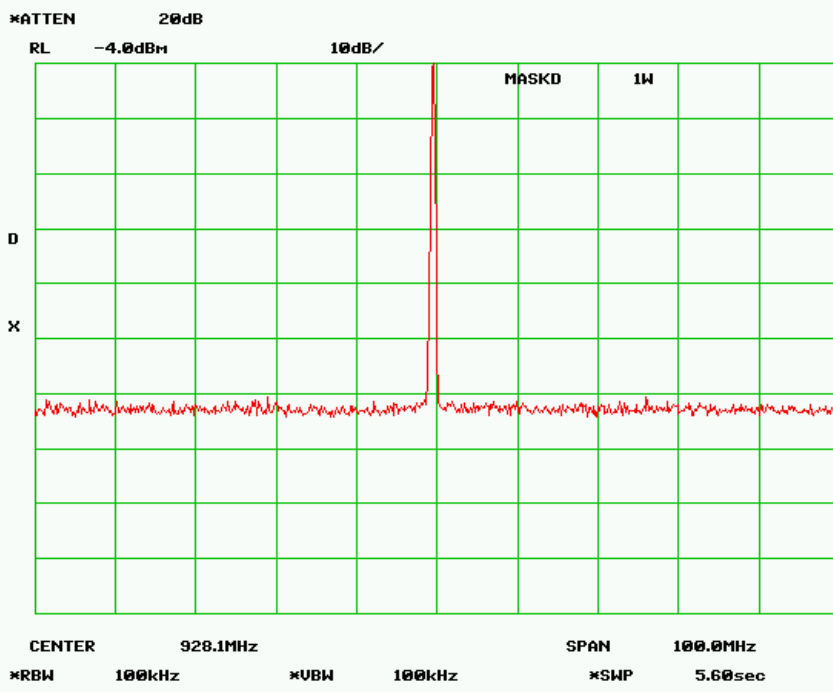
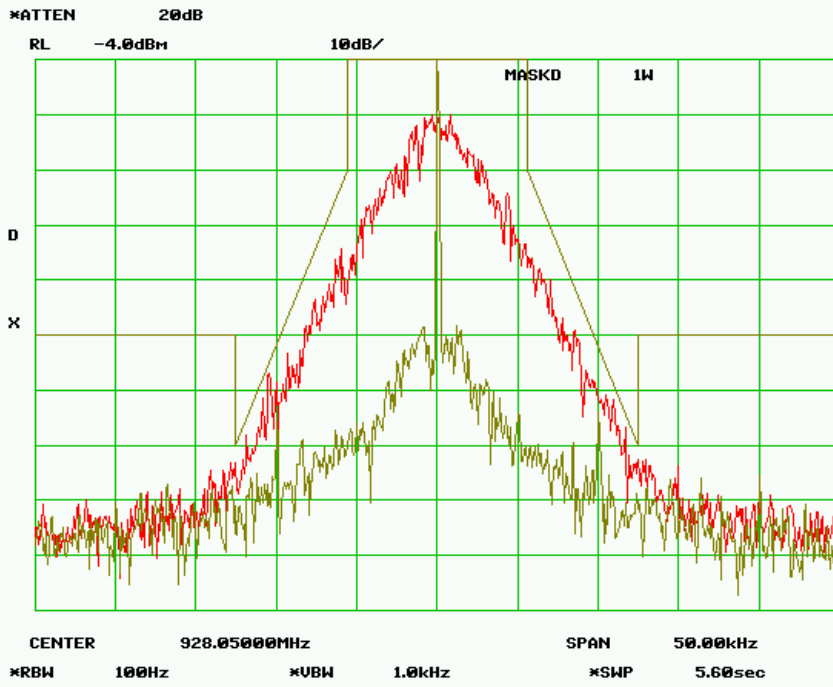

MASK D – 10.0 Watts
RF Frequency 928.050 MHz
SPECTRUM FOR EMISSION - 8K30F1D
Data Rate = 16 kbps
PEAK DEVIATION = 3.70 kHz

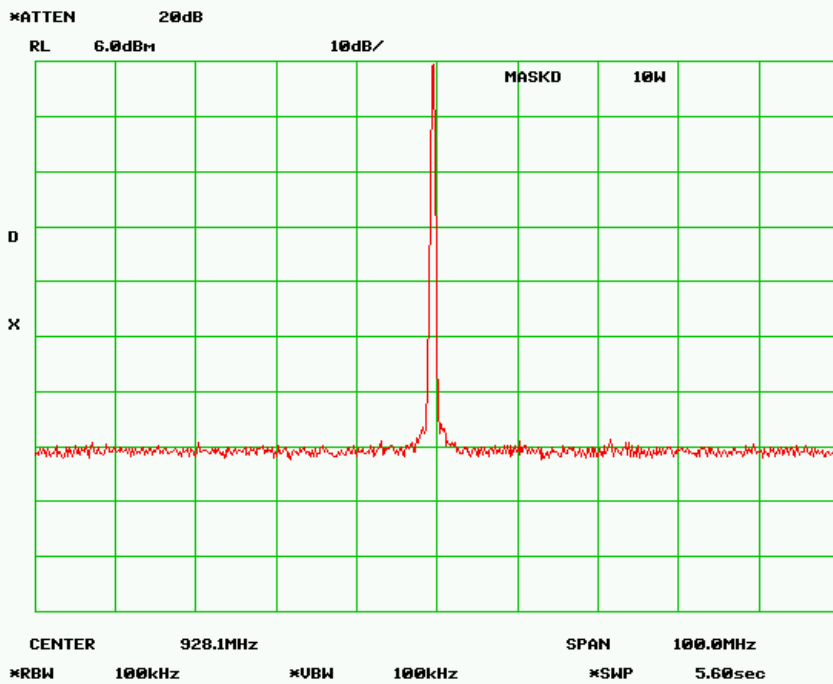
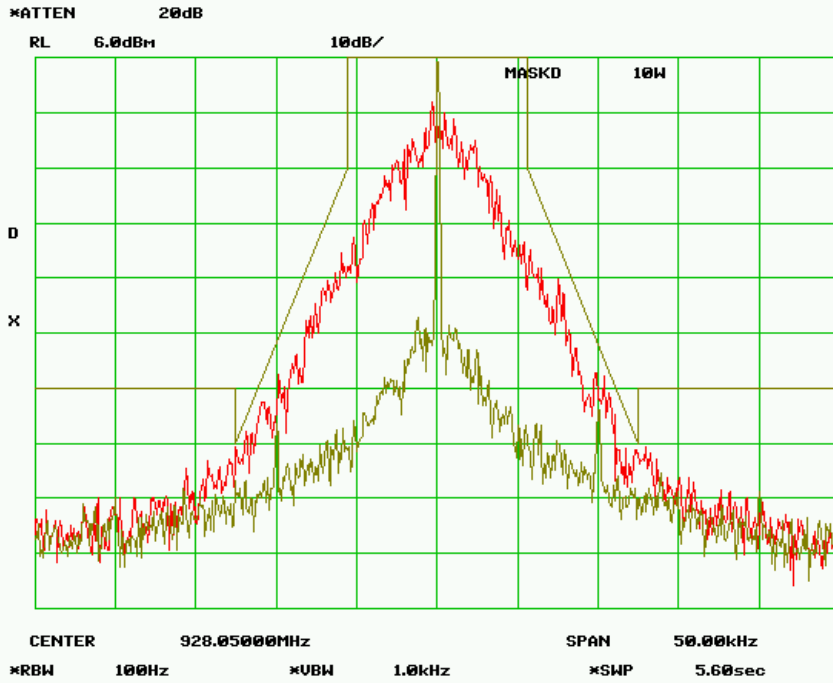

MASK D – 1.0 Watts
RF Frequency 928.050 MHz
SPECTRUM FOR EMISSION - 8K50F1D
Data Rate = 24 kbps
PEAK DEVIATION = 3.725 kHz

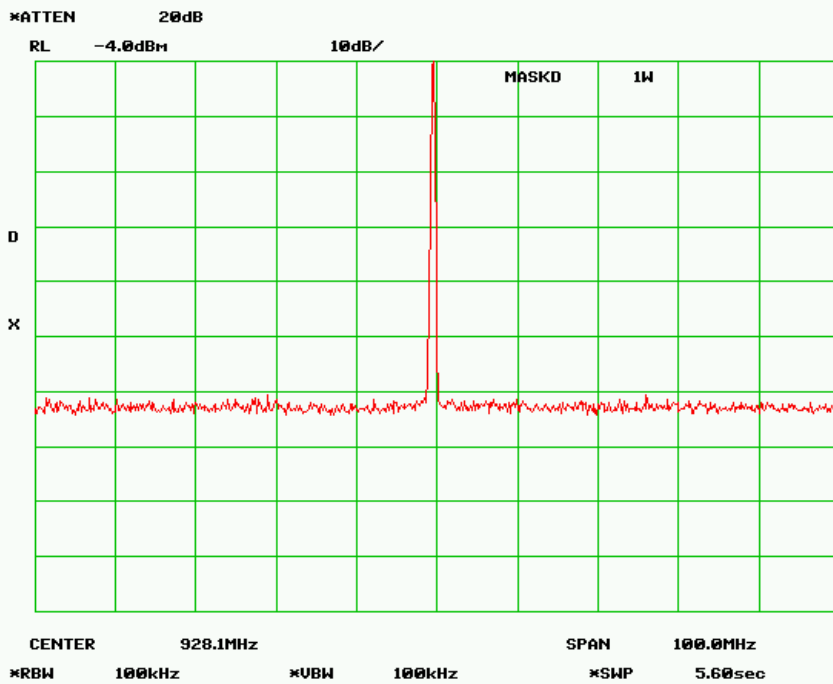
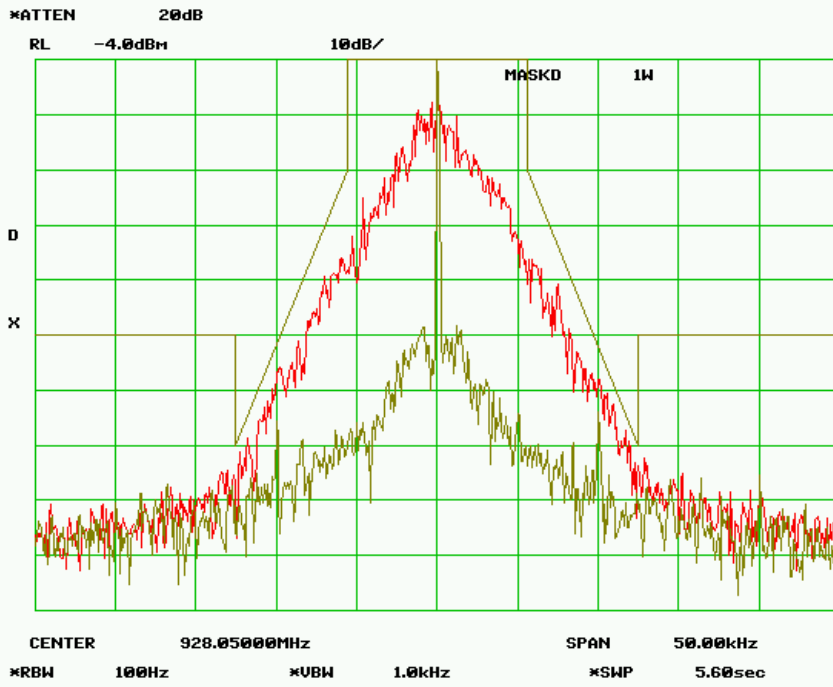

MASK D – 10.0 Watts
RF Frequency 928.050 MHz
SPECTRUM FOR EMISSION - 8K50F1D
Data Rate = 24 kbps
PEAK DEVIATION = 3.725 kHz

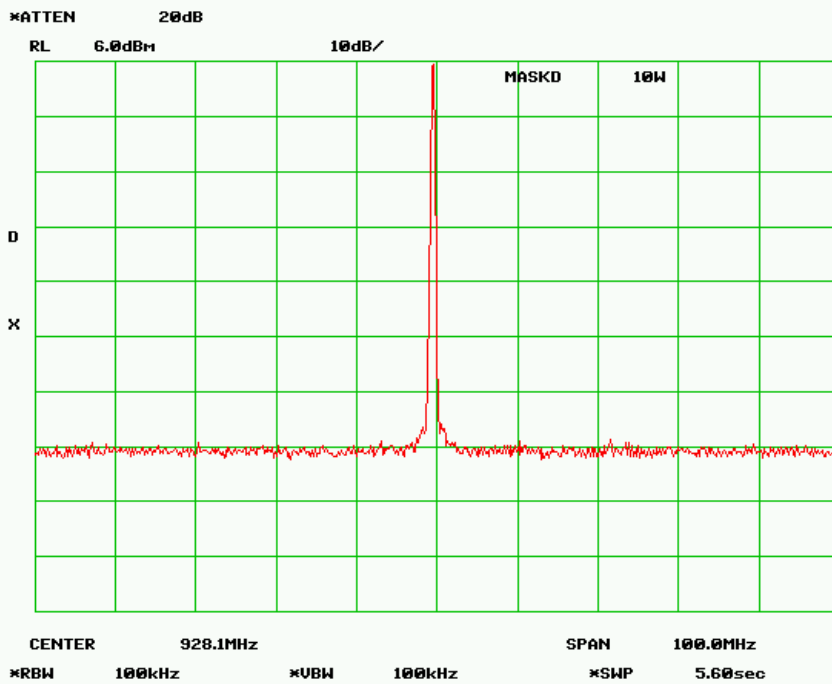
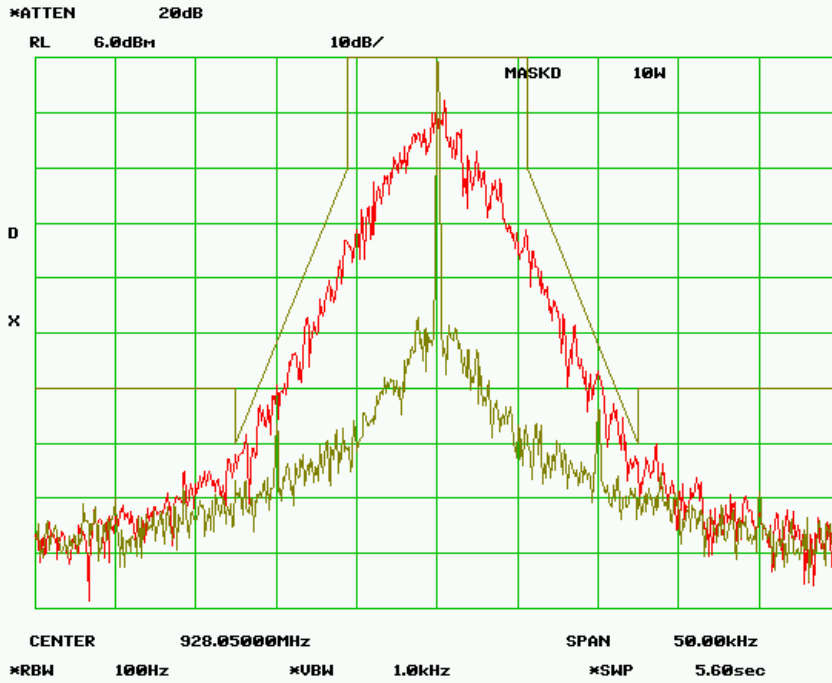

MASK D – 1.0 Watts
RF Frequency 928.050 MHz
SPECTRUM FOR EMISSION - 8K08F1D
Data Rate = 32 kbps
PEAK DEVIATION = 3.728 kHz

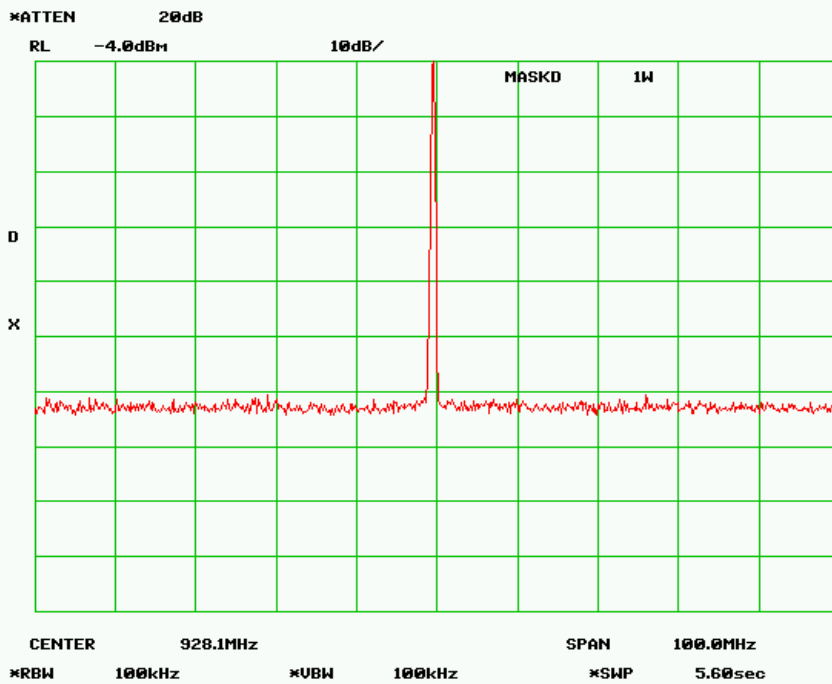
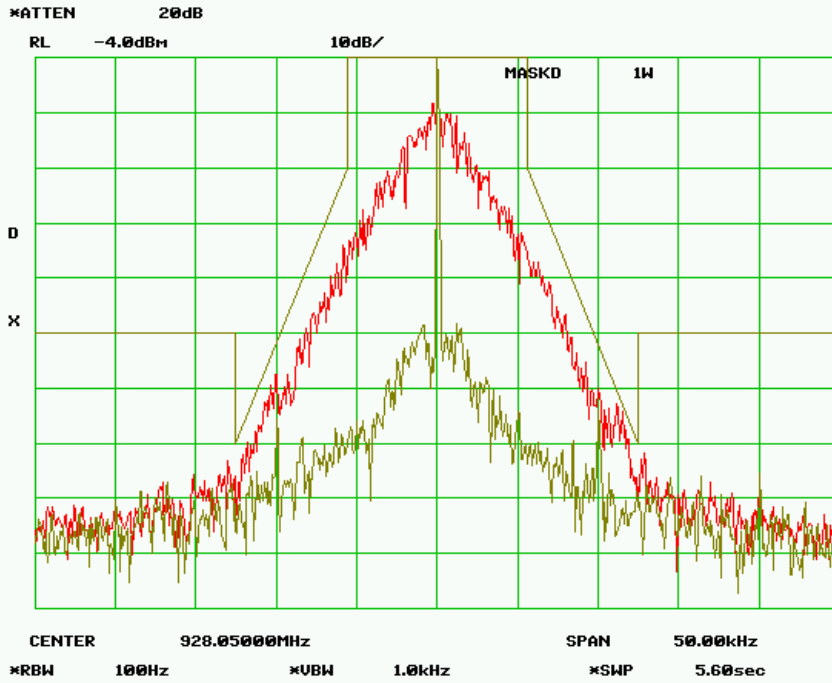

MASK D – 10.0 Watts
RF Frequency 928.050 MHz
SPECTRUM FOR EMISSION - 8K08F1D
Data Rate = 32 kbps
PEAK DEVIATION = 3.728 kHz

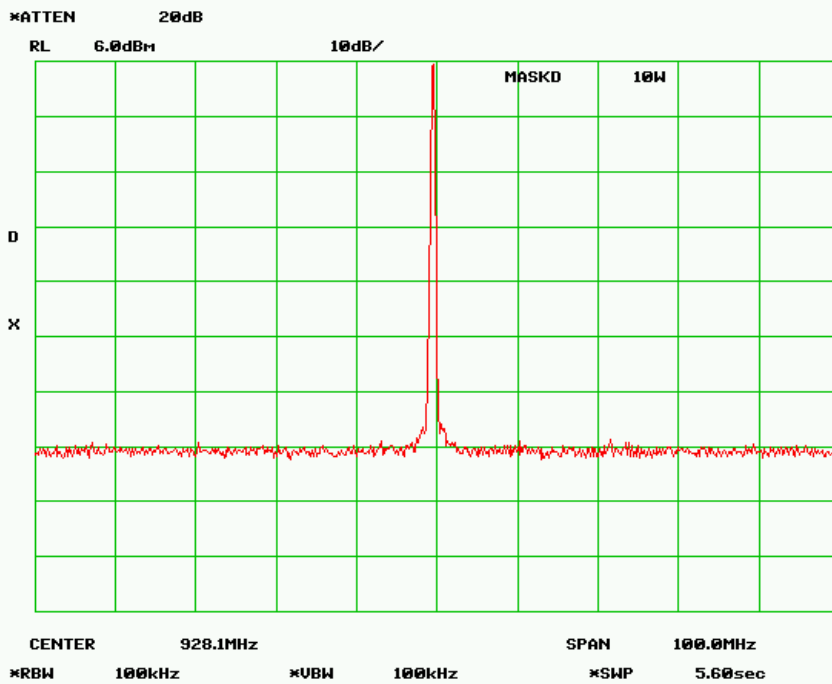
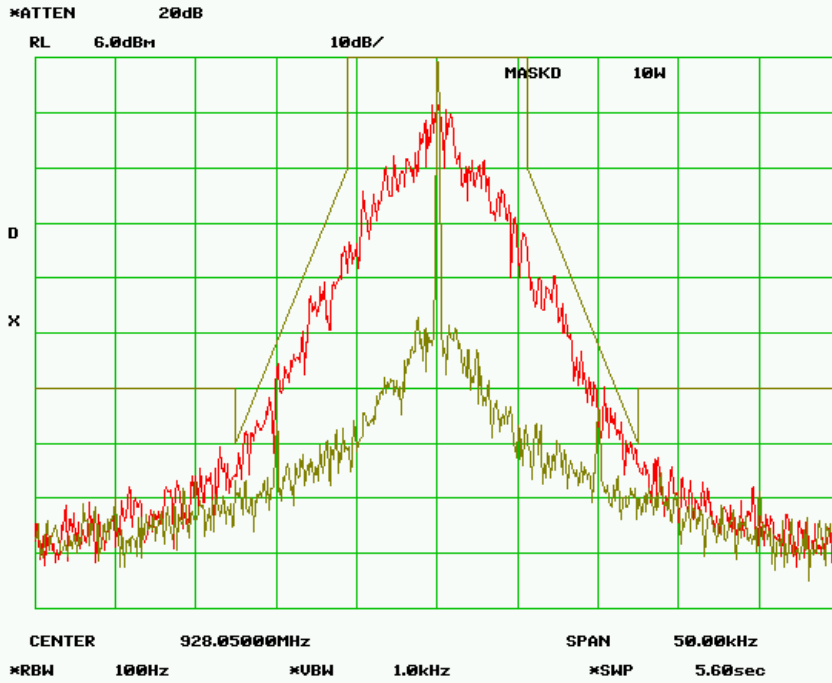

8.0 Mask C - Part 90.210(c) – 20 kHz ABW

NAME OF TEST: Transmitter Occupied Bandwidth for Emission Designators
16K5F1D, 16K8F1D, 17K8F1D, and 17K0F1D

RULE PART NUMBER: FCC: 2.202, 90.209 (b)(5), 90.210(c), 2.1049 (c) (1);

MINIMUM STANDARDS: **Mask C**
Sidebands and Spurious [Rule 90.210 (c), P = 10 Watts and P = 1 Watt]
Authorized Bandwidth = 20 kHz [Rule 90.209(b) (5)]
From Fo to 5 kHz, down 0 dB.
Greater than 5 kHz to 10 kHz, down $83 * \log_{10}(f_d / 5)$ dB.
Greater than 10 kHz to 250% of authorized BW, at least $29 * \log_{10}(f_d^2 / 11)$ or 50 dB, whichever is the lesser attenuation
Greater than 250% of authorized BW, $43 + 10\log_{10}(P)$

Attenuation = 0 dB at Fo to 5.00 kHz
Attenuation = 25 dB at 10.0 kHz
Attenuation = 27.8 dB at >10.0 kHz
Attenuation = 35.4 dB at 13.5 kHz
Attenuation = 41.3 dB at 17.1 kHz
Attenuation = 46.0 dB at 20.6 kHz
Attenuation = 50 dB at 24.1 kHz
Attenuation = 50 dB at 50 kHz
Attenuation = 53 dB at frequencies greater than 50 kHz @ 10 W
Attenuation = 43 dB at frequencies greater than 50 kHz @ 1 W

TEST RESULTS: Meets minimum standards (see data on following page)

TEST CONDITIONS: Standard Test Conditions, 25 C
RF Power Level = 1 Watt and 10 Watts
Voltage = 20VDC

TEST PROCEDURE: TIA/EIA – 603-C

TEST EQUIPMENT: 50-Ohm Attenuator, Bird Electronics Model 50-A-FFN-20 (20dB, 50W)
50-Ohm Attenuator, Bird Electronics Model 10-A-MFN-10 (10dB, 10W)
50-Ohm Attenuator, Pasternack Model PE7002-10 (10dB)
DC Power Supply, Hewlett Packard Model 6653A
Spectrum Analyzer, Hewlett Packard Model HP8563E
Modulation Analyzer, Hewlett Packard Model HP8901A

TEST SET-UP:

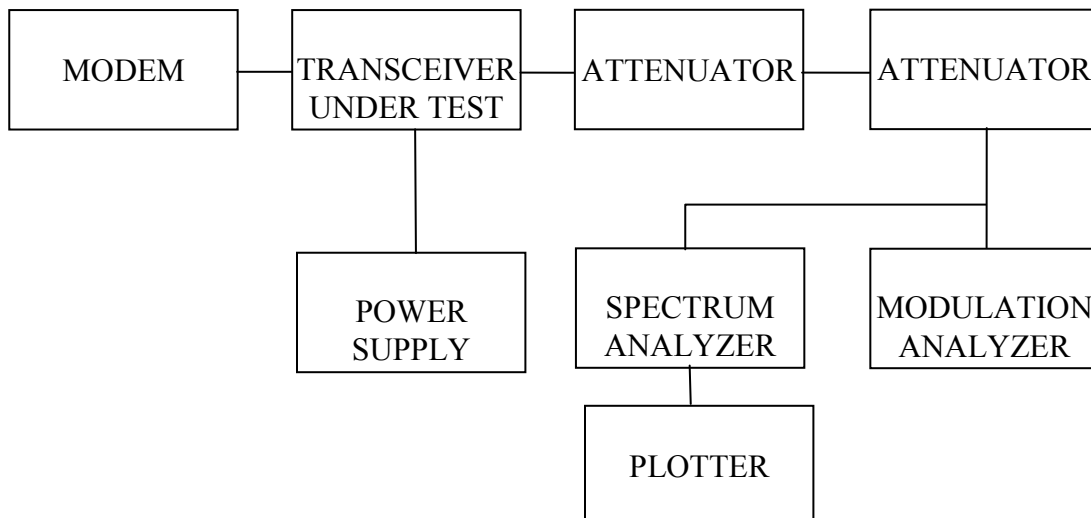

MASK C – 1.0 Watt
RF Frequency 928.050 MHz
SPECTRUM FOR EMISSION - 16K5F1D
 Data Rate = 16 kbps
 PEAK DEVIATION = 6.30 kHz

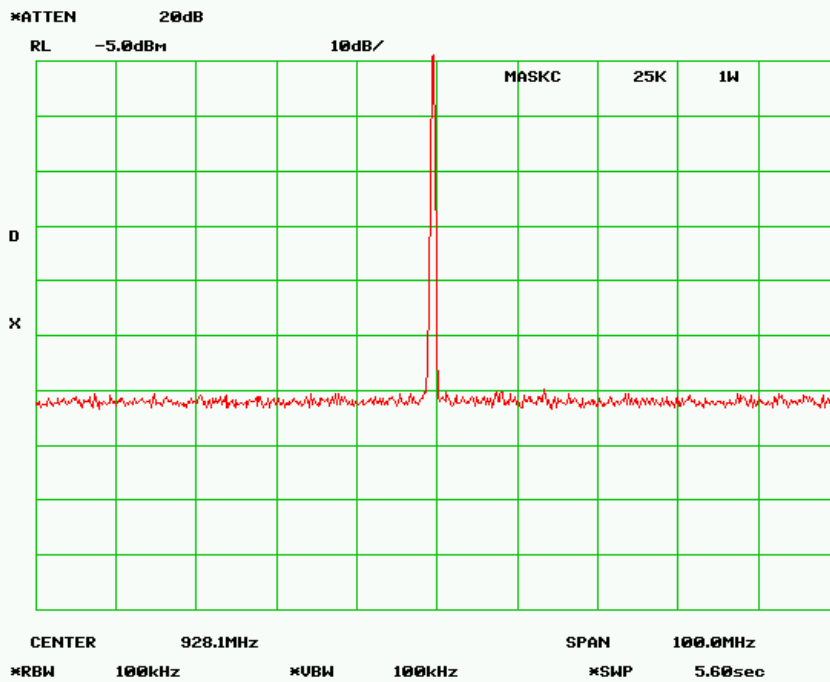
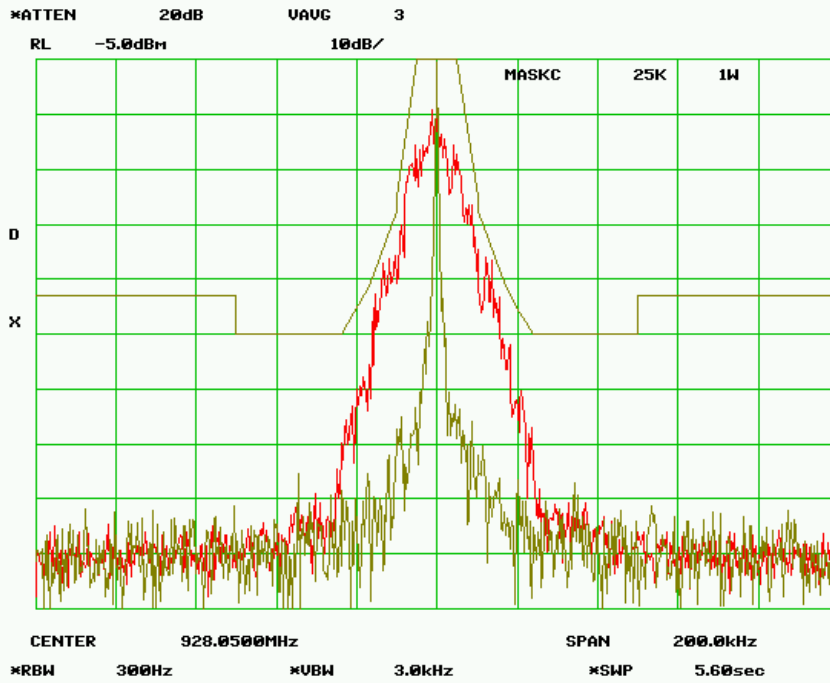

MASK C – 10 Watts
RF Frequency 928.050 MHz
SPECTRUM FOR EMISSION - 16K5F1D
 Data Rate = 16 kbps
 PEAK DEVIATION = 6.30 kHz

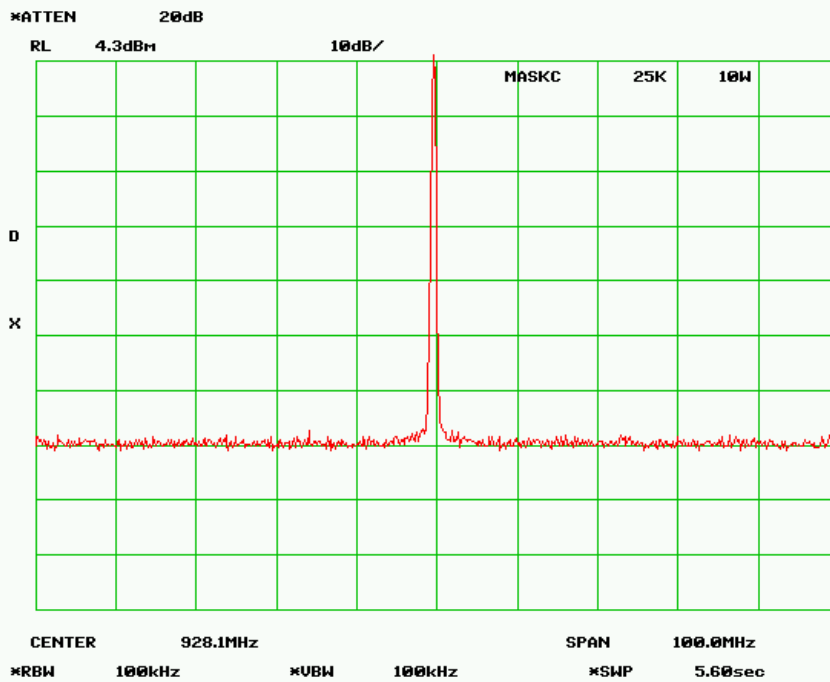
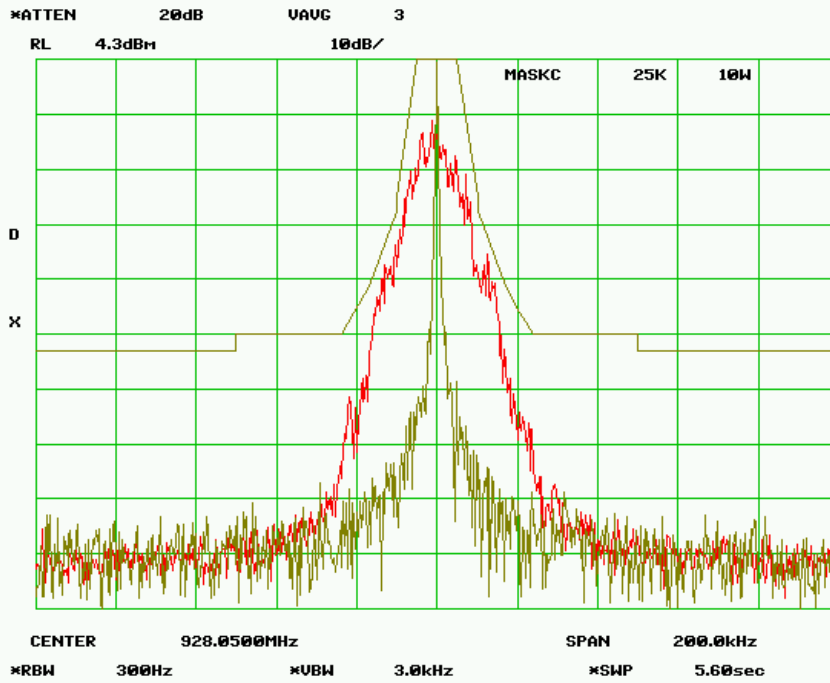

MASK C - 1.0 Watt
RF Frequency 928.050 MHz
SPECTRUM FOR EMISSION - 16K8F1D
Data Rate = 32 kbps
PEAK DEVIATION = 6.30 kHz

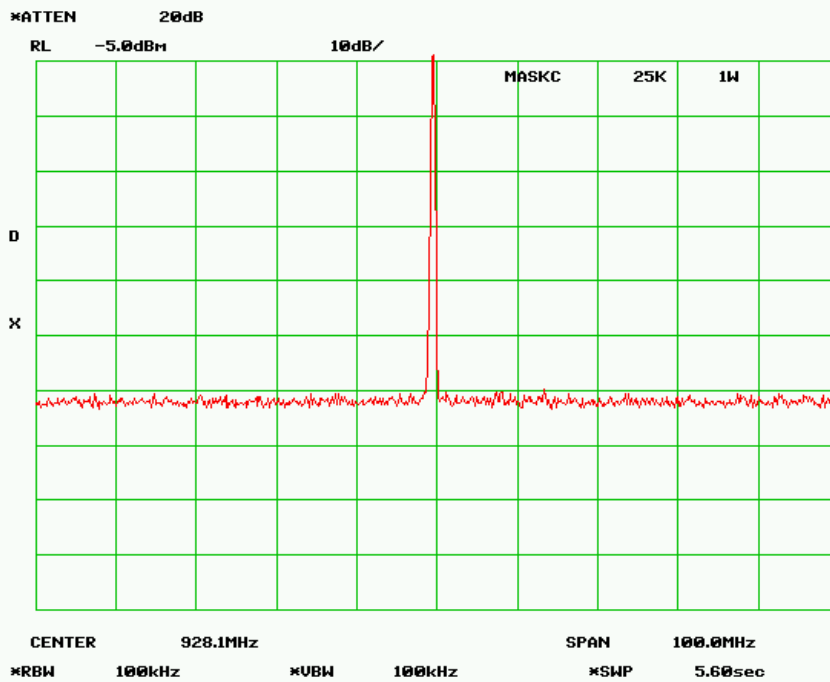
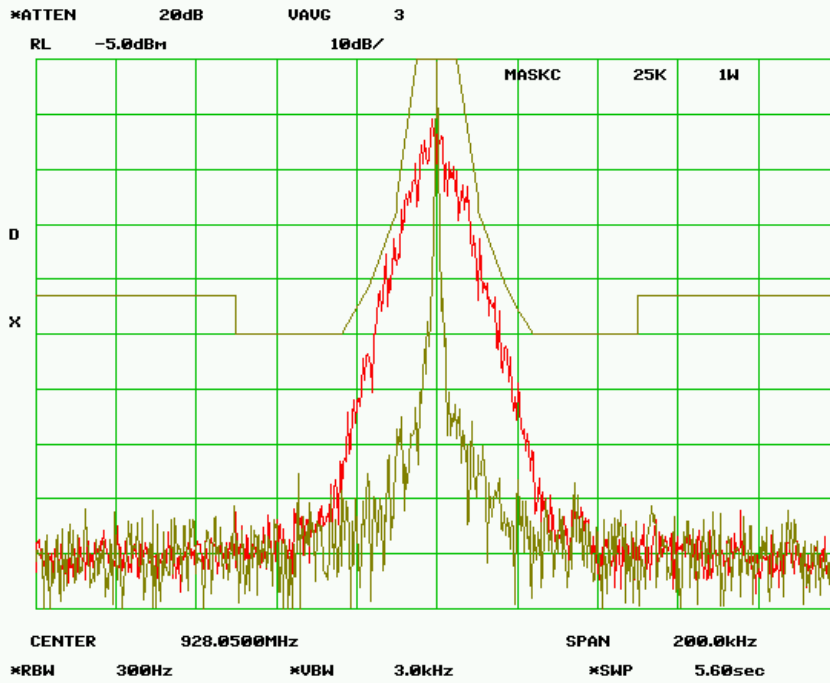

MASK C - 10 Watts
RF Frequency 928.050 MHz
SPECTRUM FOR EMISSION - 16K8F1D
 Data Rate = 32 kbps
 PEAK DEVIATION = 6.30 kHz

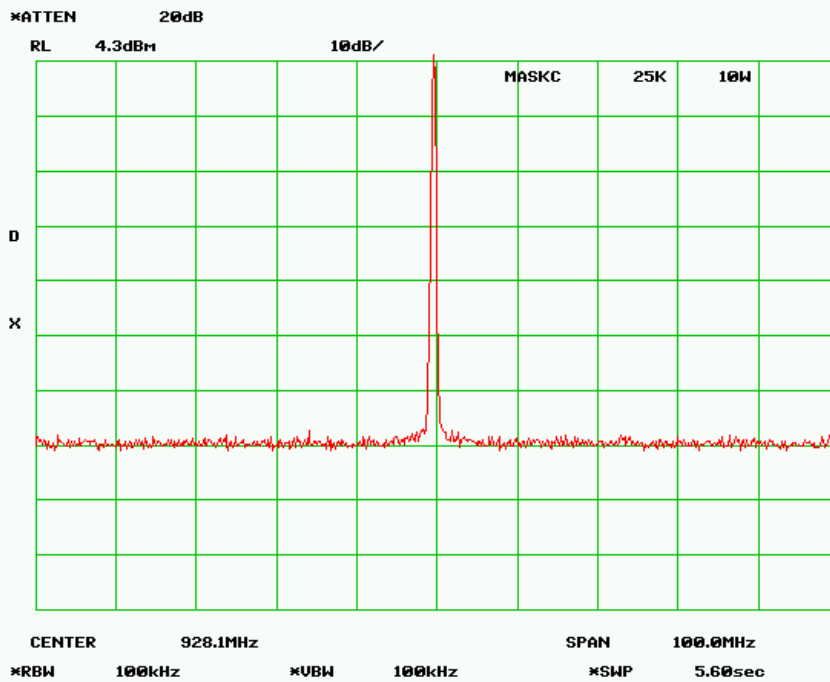
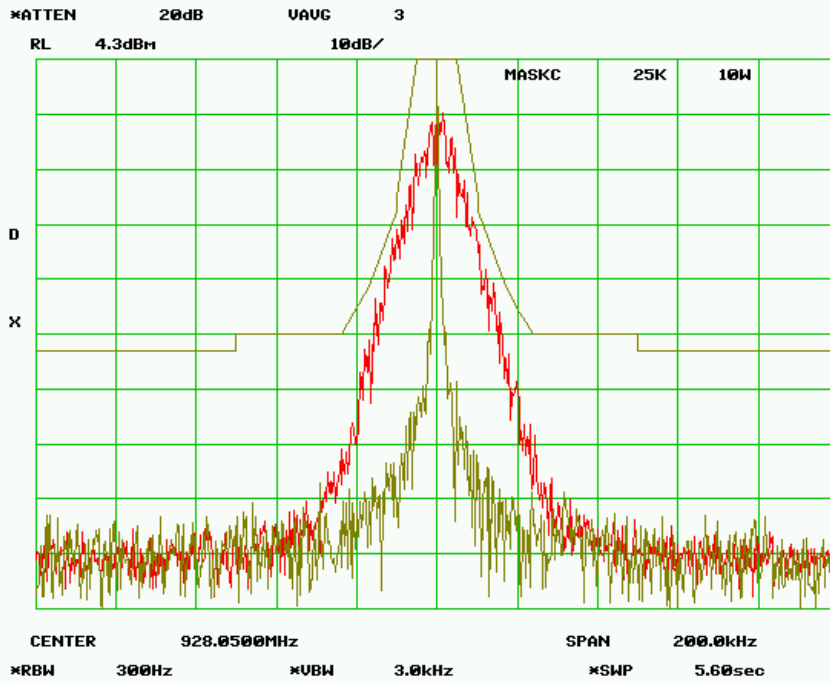

MASK C - 1.0 Watt
RF Frequency 928.050 MHz
SPECTRUM FOR EMISSION - 17K8F1D
Data Rate = 48 kbps
PEAK DEVIATION = 7.590 kHz

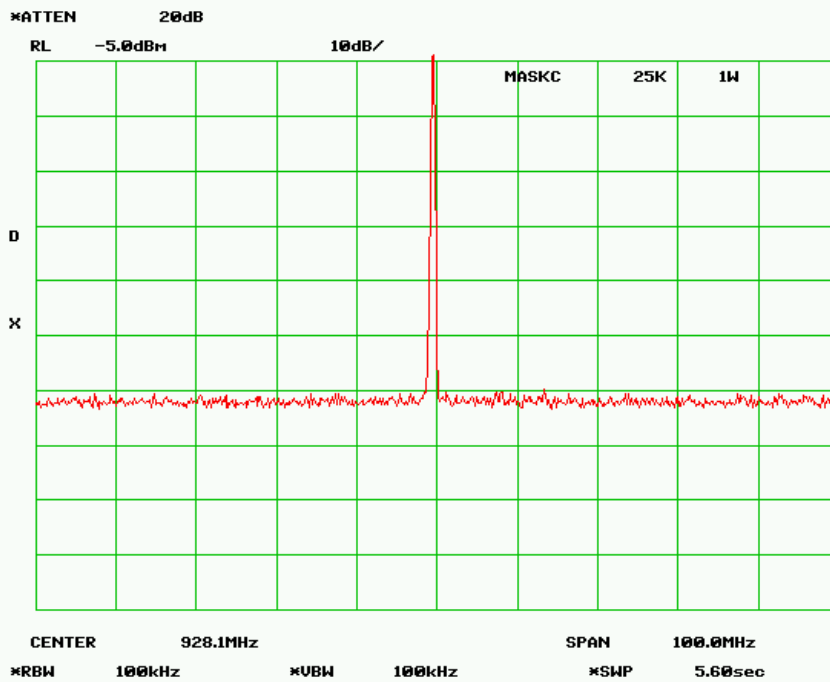
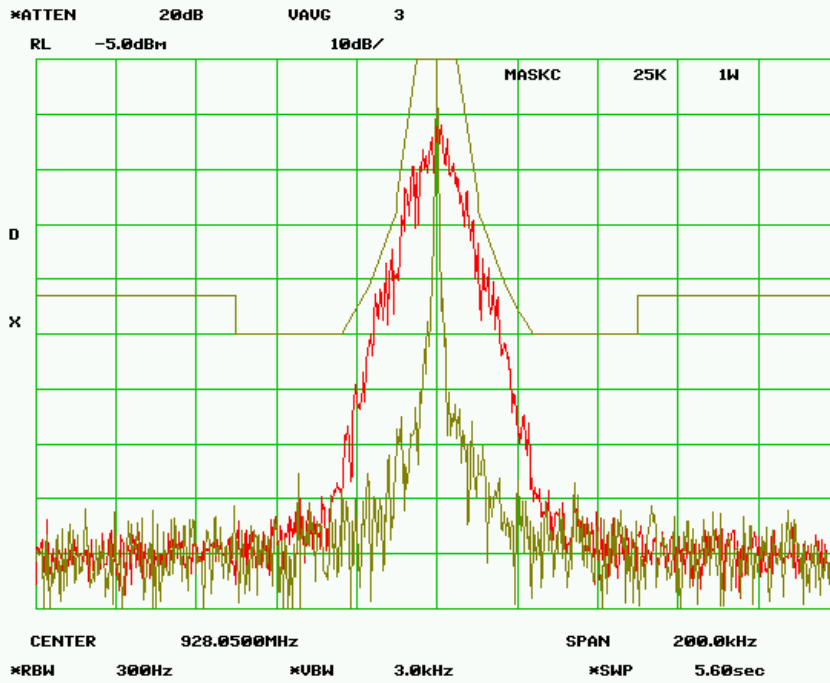

MASK C - 10 Watts
RF Frequency 928.050 MHz
SPECTRUM FOR EMISSION - 17K8F1D
 Data Rate = 48 kbps
 PEAK DEVIATION = 7.590 kHz

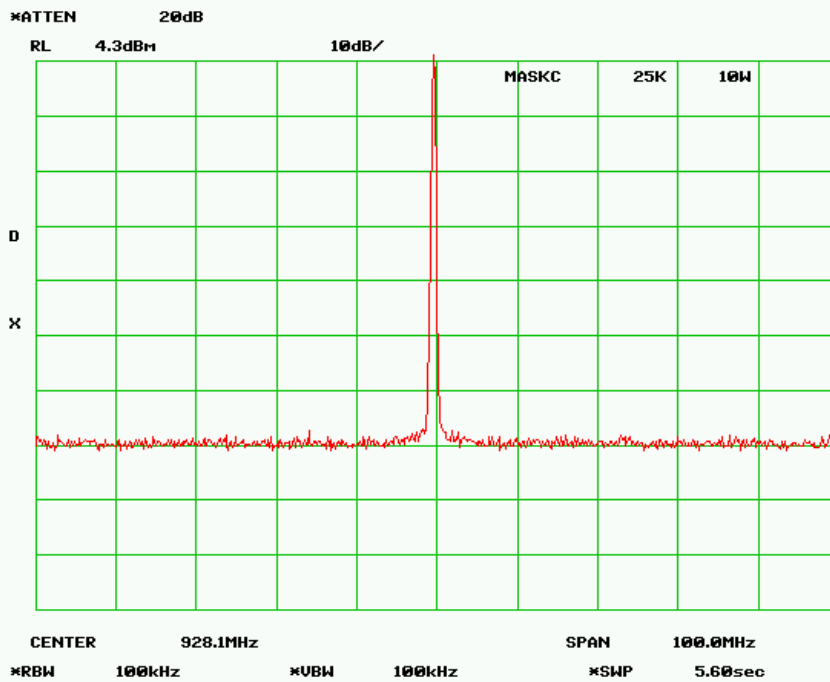
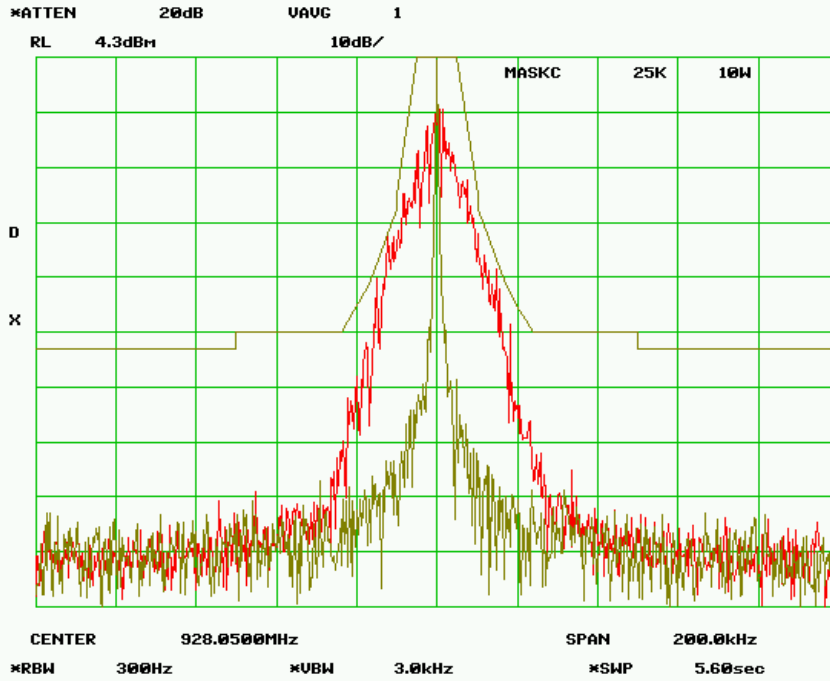

MASK C - 1.0 Watt
RF Frequency 928.050 MHz
SPECTRUM FOR EMISSION - 17K0F1D
Data Rate = 64 kbps
PEAK DEVIATION = 7.520 kHz

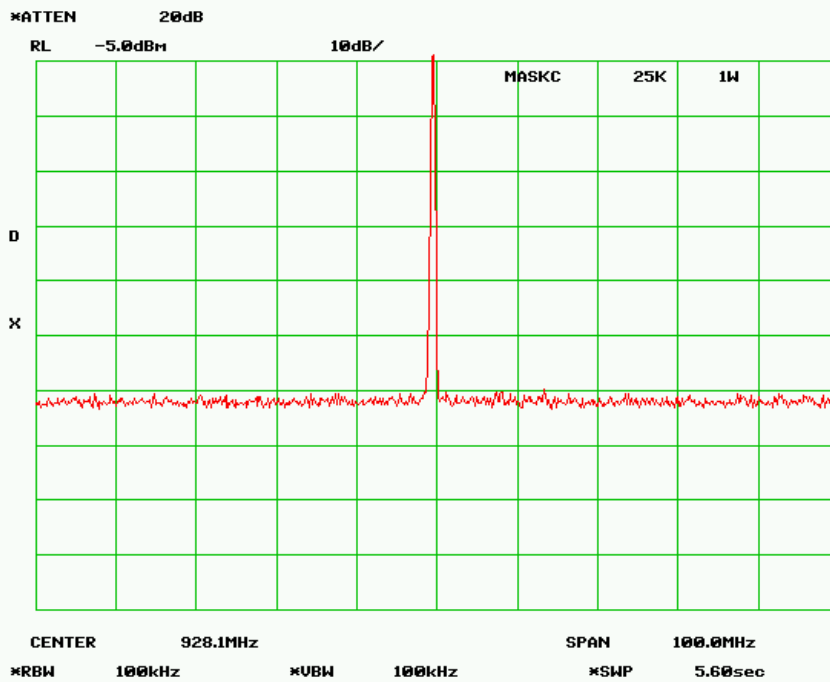
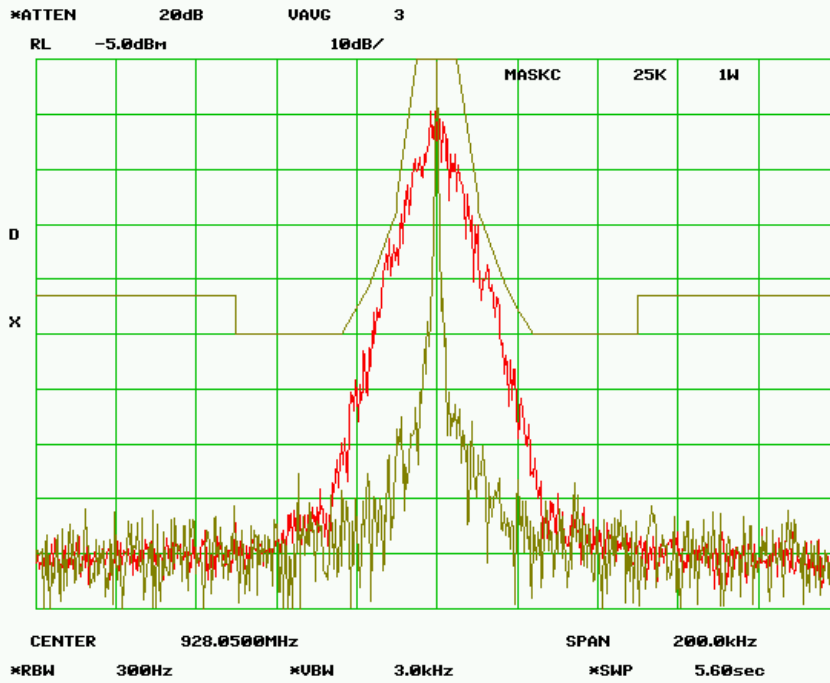

MASK C - 10 Watts
RF Frequency 928.050 MHz
SPECTRUM FOR EMISSION - 17K0F1D
 Data Rate = 64 kbps
 PEAK DEVIATION = 7.520 kHz

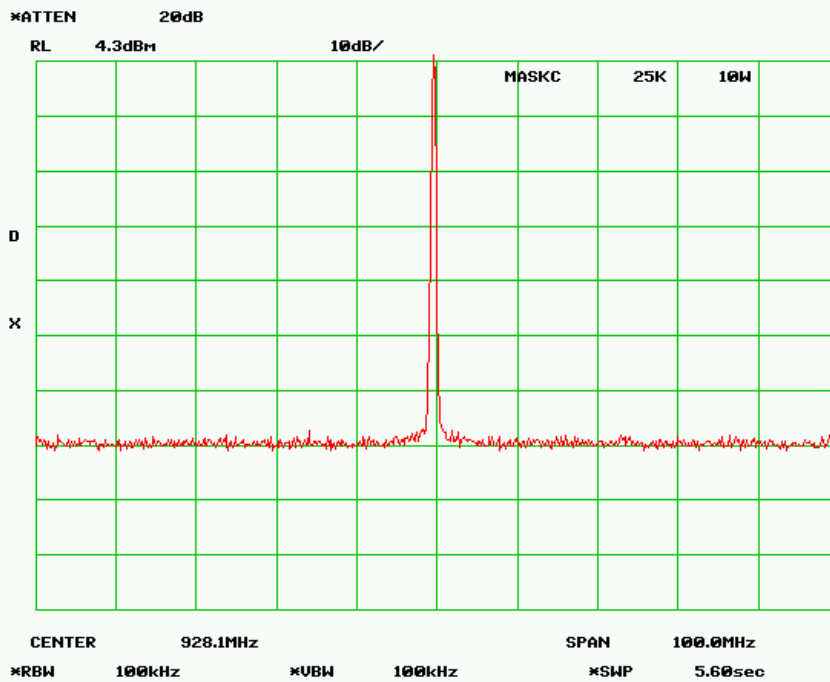
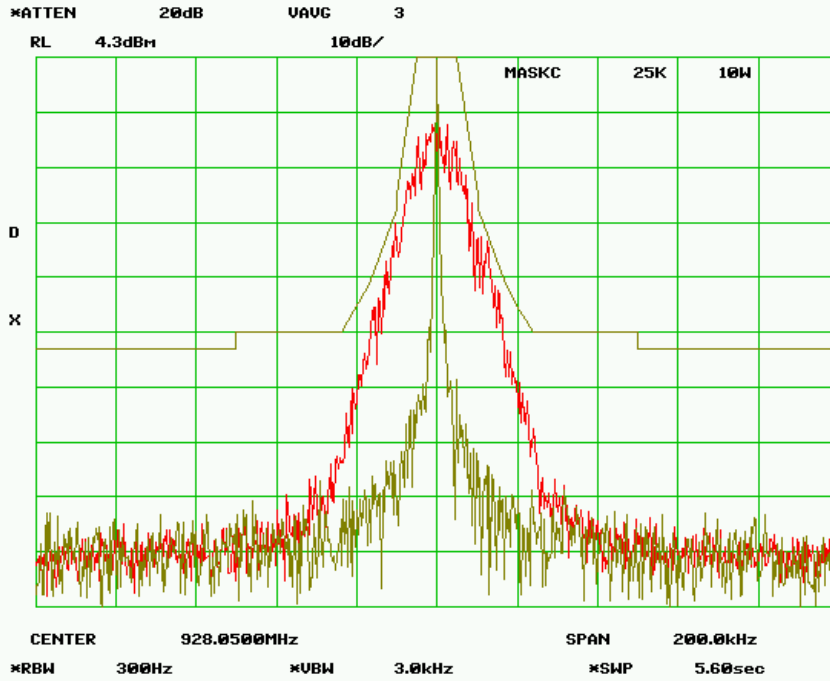

9.0 Mask J - Part 90.210(j) – 13.6 kHz ABW

NAME OF TEST: Transmitter Occupied Bandwidth for Emission Designators
3K30F1D, 3K55F1D, and 3K20F1D
8K20F1D, 8K30F1D, 8K50F1D and 8K08F1D

RULE PART NUMBER: FCC: 2.202, 90.209 (b)(5), 90.210(j), 2.1049 (c) (1)

MINIMUM STANDARDS: **Mask J**
 Sidebands and Spurious [Rule 90.210 (d), P = 10 Watts and P=1 Watt]
 Authorized Bandwidth = 13.6 kHz [Rule 90.209(b) (5)]
 Fo of more than 2.5 kHz, but no more than 6.25 kHz: At least 53 log (f_d/2.5) dB
 Fo of more than 6.25 kHz, but no more than 9.5 kHz: At least 103 log (f_d/3.9) dB;
 Fo of more than 9.5 kHz: At least 157 log (f_d/5.3) dB, or 50 + 10 log (P) dB or 70 dB,
 whichever is the lesser attenuation.

Attenuation = 0 dB at Fo to 2.50 kHz
 Attenuation = 21 dB at 6.25 kHz
 Attenuation = 39.8 at 9.50 kHz
 Attenuation = 60 dB at frequencies greater than 12.8 kHz @ 10 W
 Attenuation = 50 dB at frequencies greater than 11.0 kHz @ 1 W

TEST RESULTS: Meets minimum standards (see data on following page)

TEST CONDITIONS: Standard Test Conditions, 25 C
 RF Power Level = 1 Watt and 10 Watts
 Voltage = 20VDC

TEST PROCEDURE: TIA/EIA – 603-C, 2.2.13, 3.2.11.2

TEST EQUIPMENT: 50-Ohm Attenuator, Bird Electronics Model 50-A-FFN-20 (20dB, 50W)
 50-Ohm Attenuator, Bird Electronics Model 10-A-MFN-10 (10dB, 10W)
 50-Ohm Attenuator, Pasternack Model PE7002-10 (10dB)
 DC Power Supply, Hewlett Packard Model 6653A
 Spectrum Analyzer, Hewlett Packard Model HP8563E
 Modulation Analyzer, Hewlett Packard Model HP8901A

TEST SET-UP:

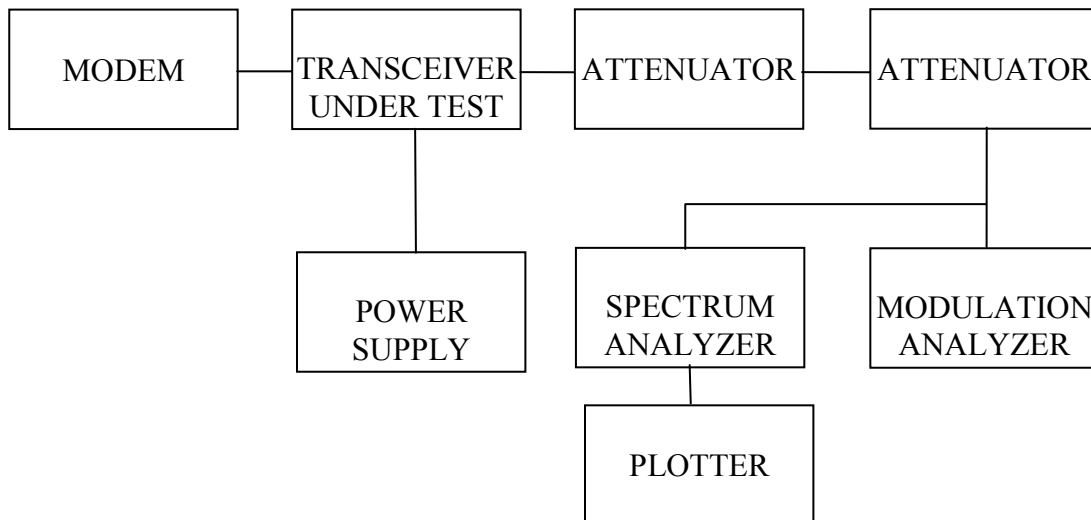

MASK J – 1.0 Watts
RF Frequency 939.500 MHz
SPECTRUM FOR EMISSION - 3K30F1D
 Data Rate = 4 kbps
 PEAK DEVIATION = 1.15 kHz

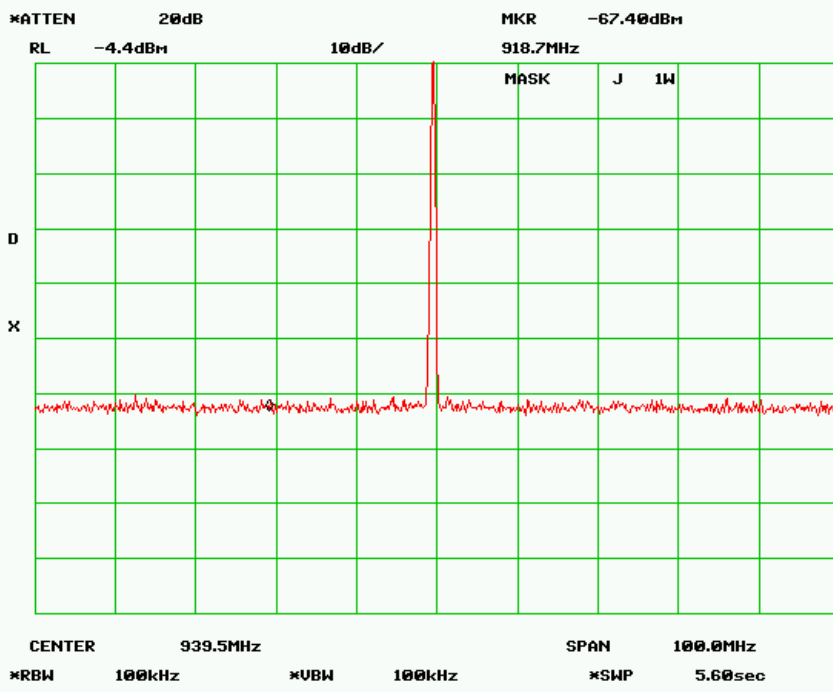
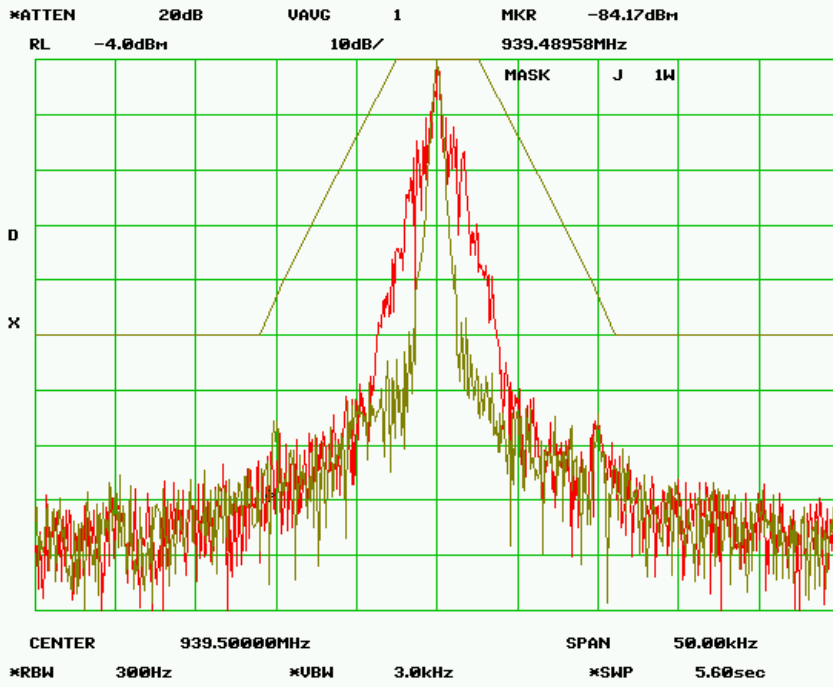

MASK J – 10.0 Watts
RF Frequency 939.500 MHz
SPECTRUM FOR EMISSION - 3K30F1D
 Data Rate = 4 kbps
 PEAK DEVIATION = 1.15 kHz

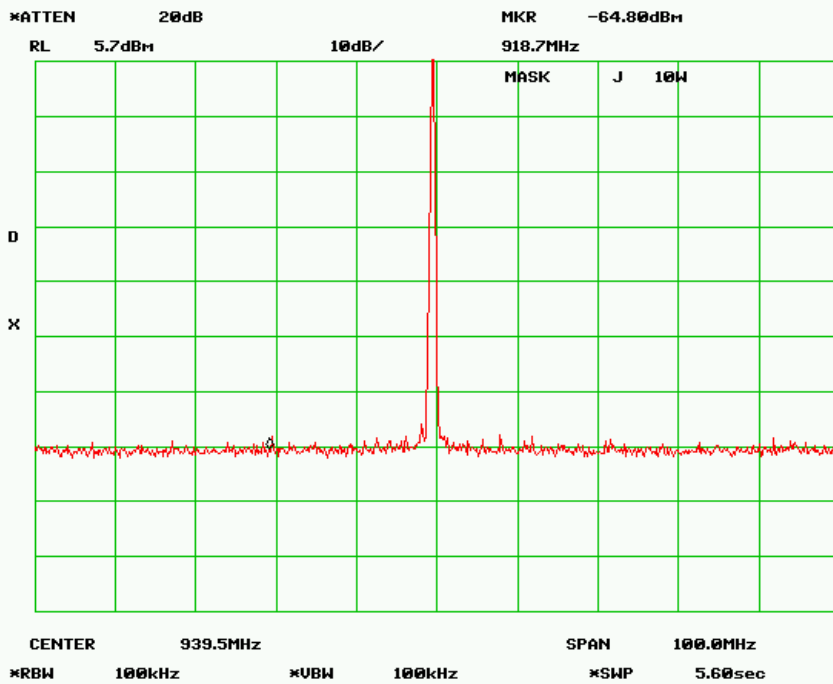
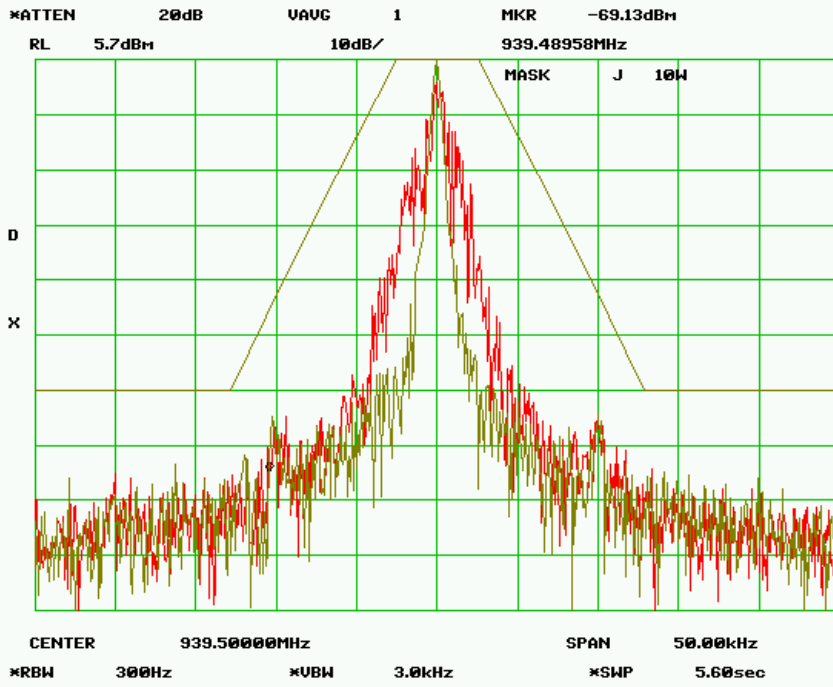

MASK J – 1.0 Watts
RF Frequency 939.500 MHz
SPECTRUM FOR EMISSION - 3K55F1D
 Data Rate = 8 kbps
 PEAK DEVIATION = 1.09 kHz

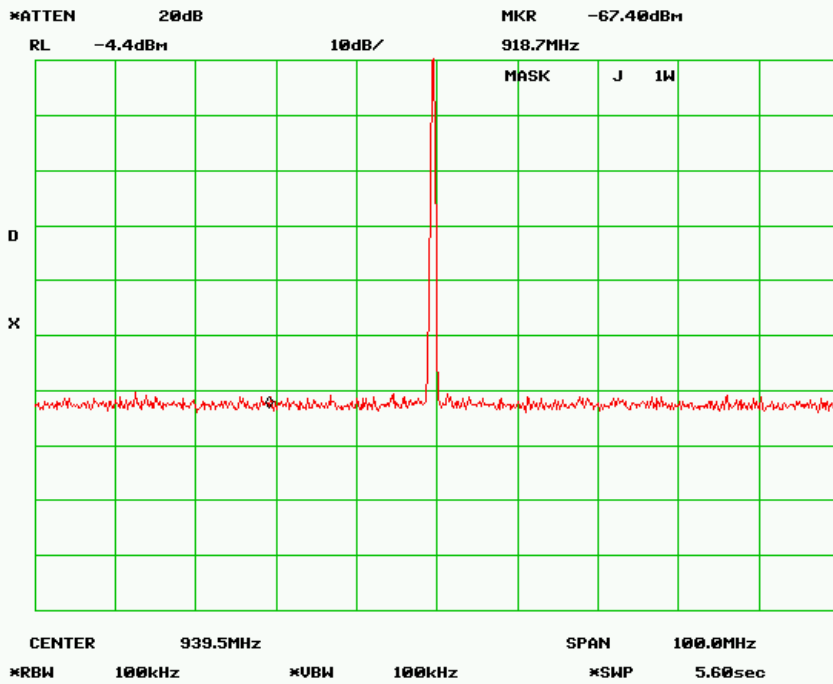
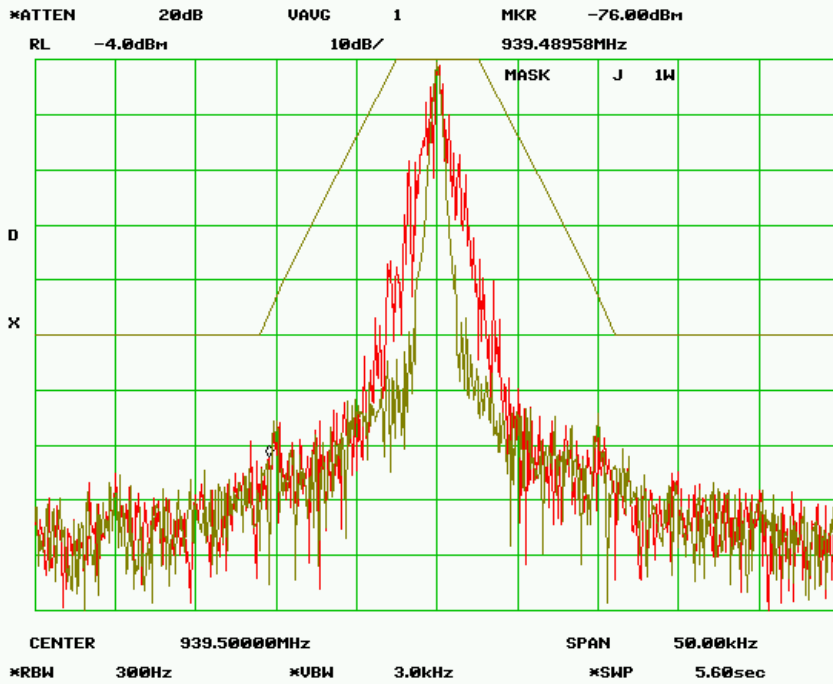

MASK J – 10.0 Watts
RF Frequency 939.500 MHz
SPECTRUM FOR EMISSION - 3K55F1D
 Data Rate = 8 kbps
 PEAK DEVIATION = 1.09 kHz

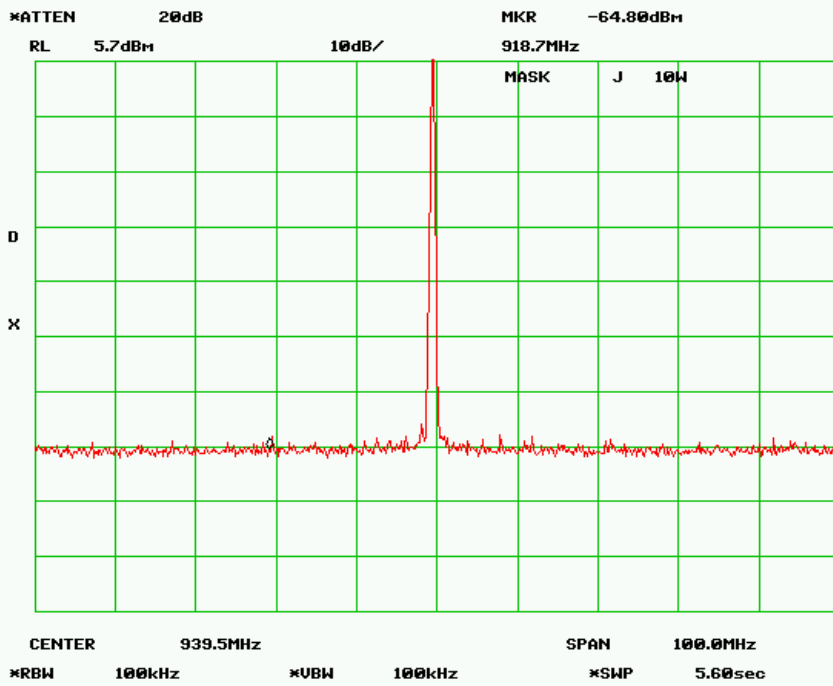
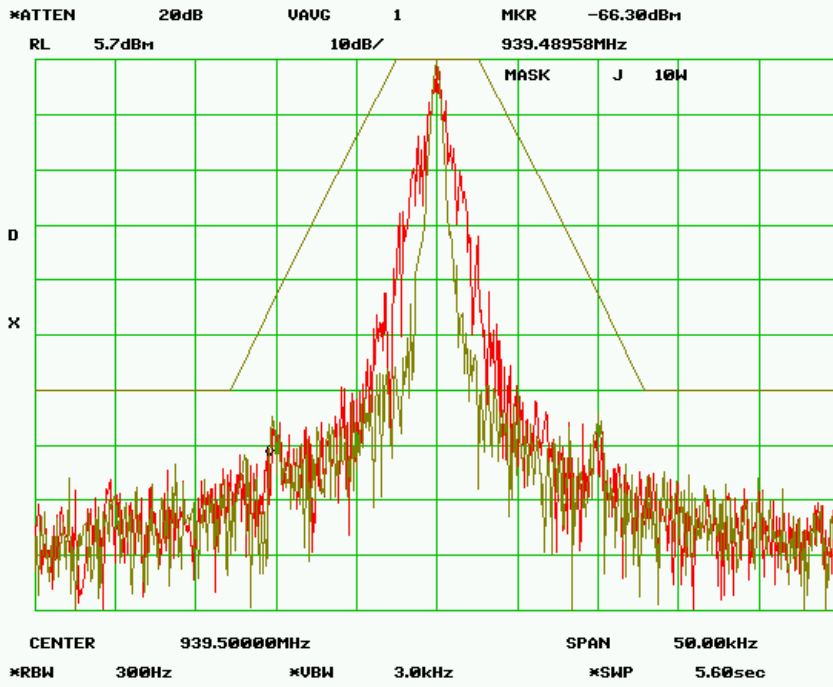

MASK J – 1.0 Watts
RF Frequency 939.500 MHz
SPECTRUM FOR EMISSION - 3K20F1D
 Data Rate = 12 kbps
 PEAK DEVIATION = 1.15 kHz

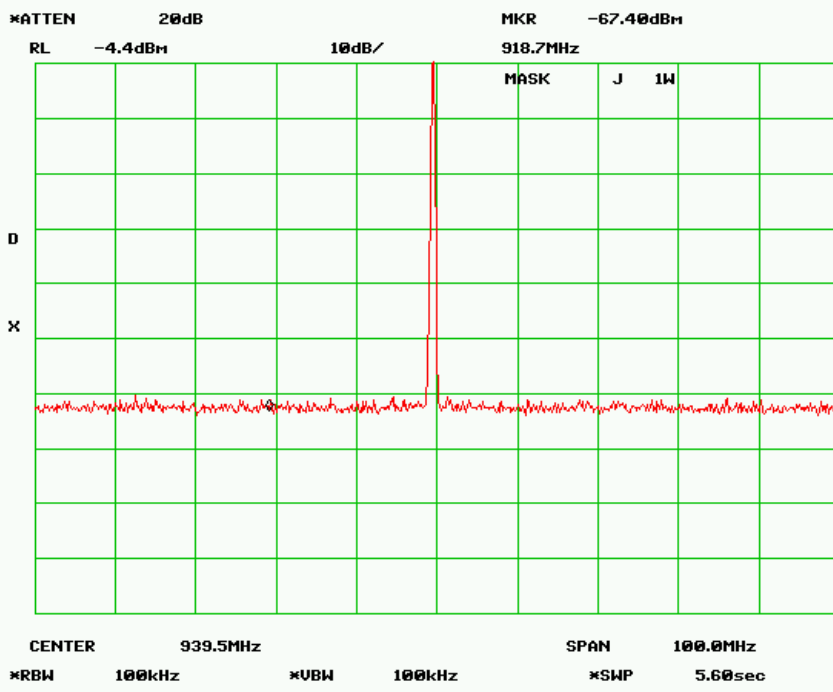
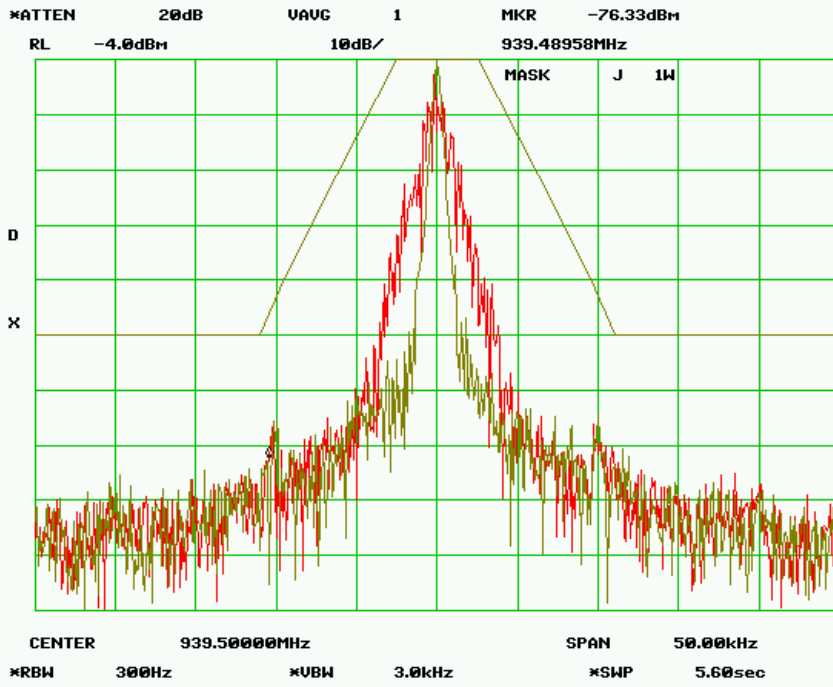

MASK J – 10.0 Watts
RF Frequency 939.500 MHz
SPECTRUM FOR EMISSION - 3K20F1D
Data Rate = 12 kbps
PEAK DEVIATION = 1.15 kHz

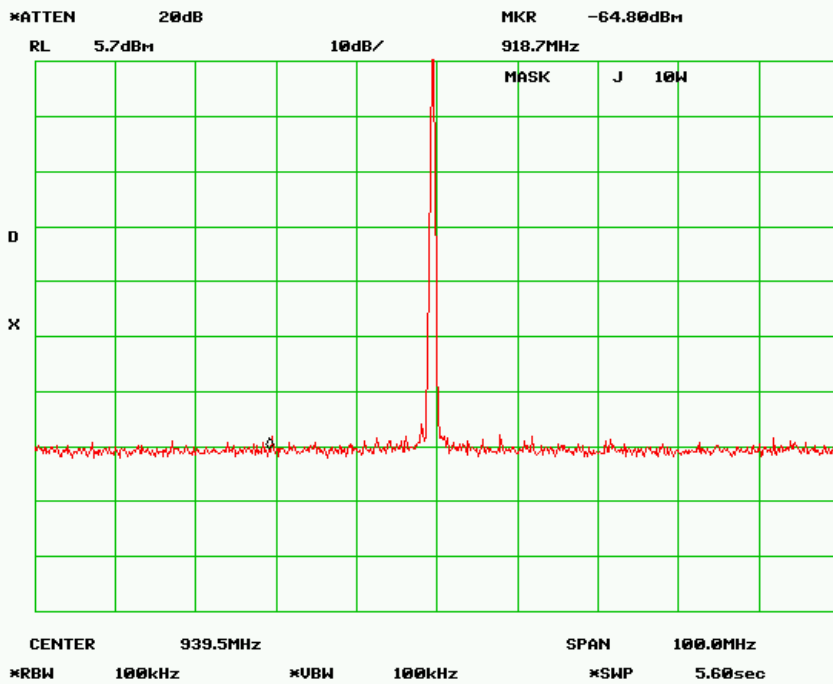
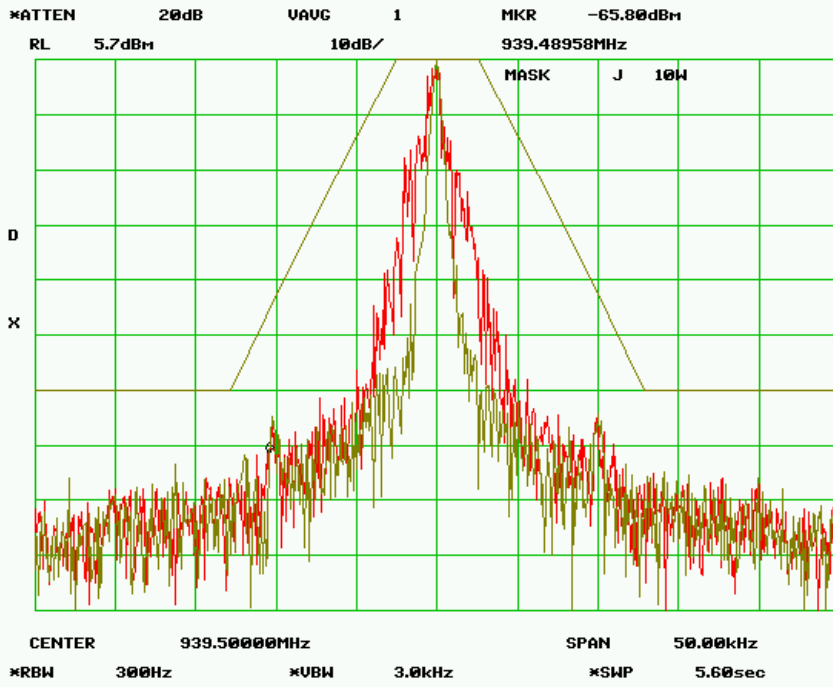

MASK J – 1.0 Watts
RF Frequency 939.500 MHz
SPECTRUM FOR EMISSION - 8K20F1D
Data Rate = 8 kbps
PEAK DEVIATION = 3.05 kHz

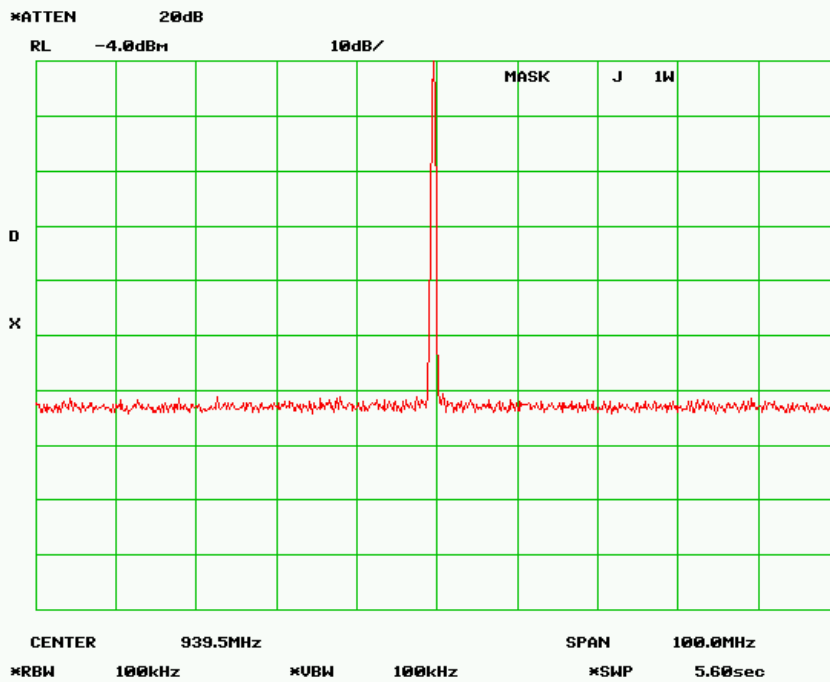
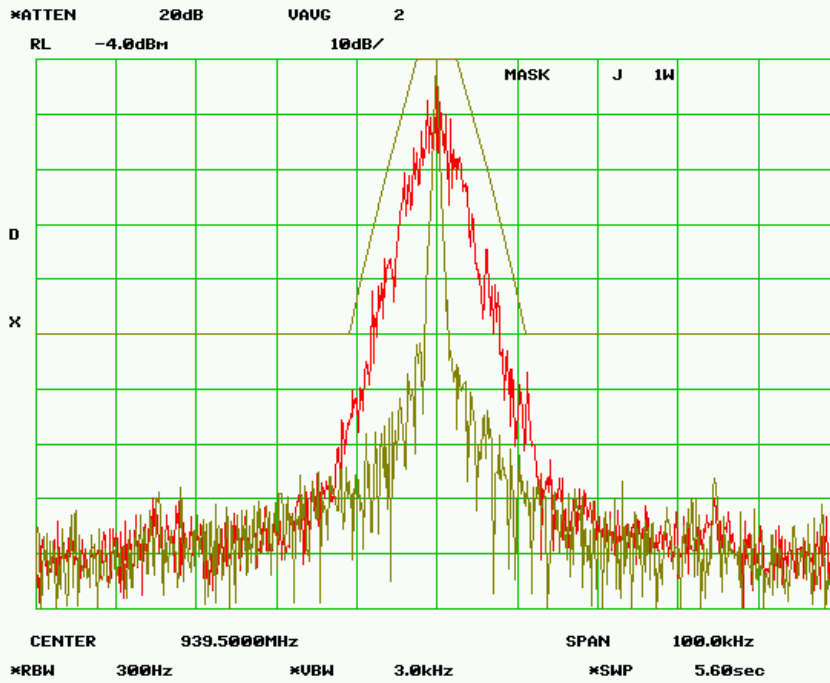

MASK J – 10.0 Watts
RF Frequency 939.500 MHz
SPECTRUM FOR EMISSION - 8K20F1D
Data Rate = 8 kbps
PEAK DEVIATION = 3.05 kHz

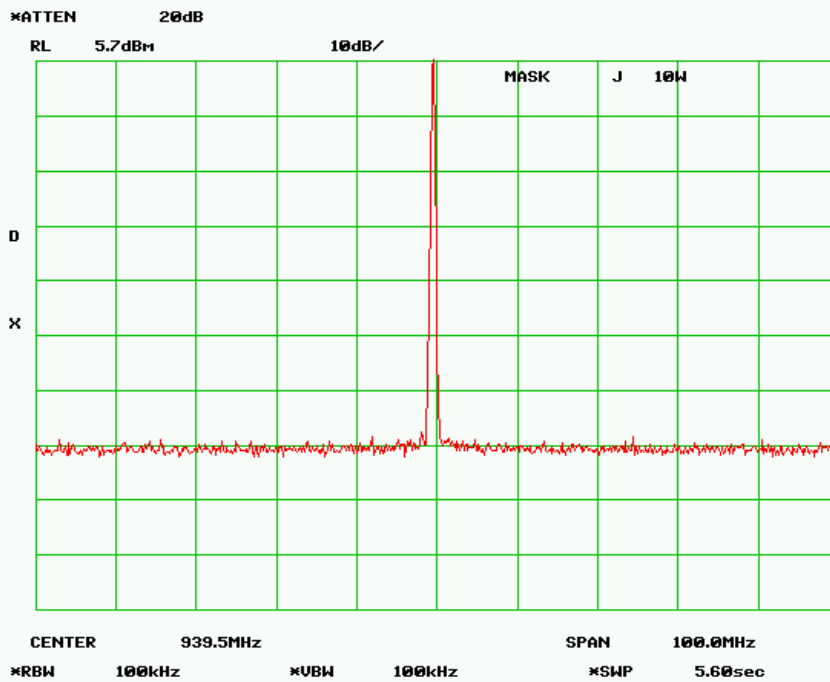
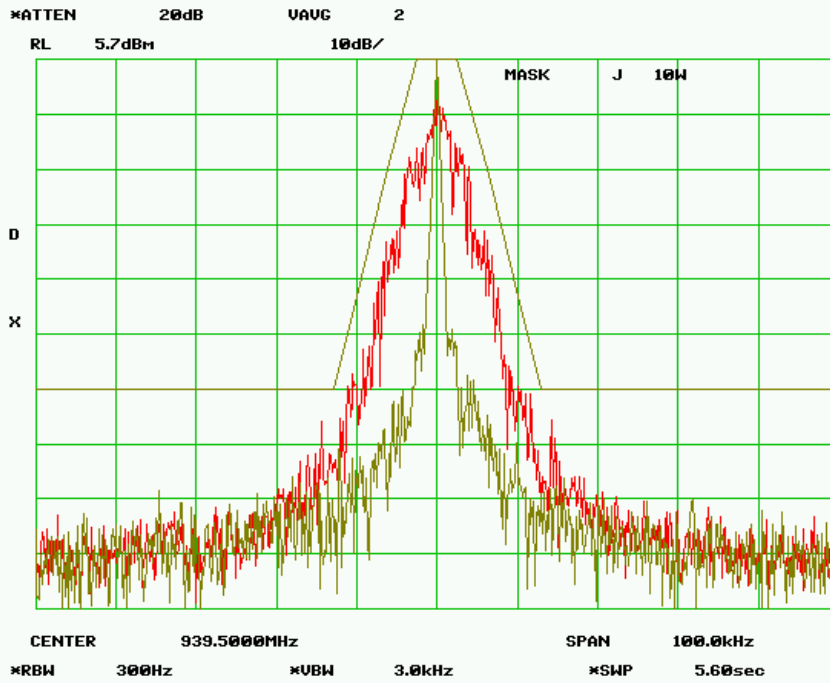

MASK J – 1.0 Watts
RF Frequency 939.500 MHz
SPECTRUM FOR EMISSION - 8K30F1D
Data Rate = 16 kbps
PEAK DEVIATION = 3.70 kHz

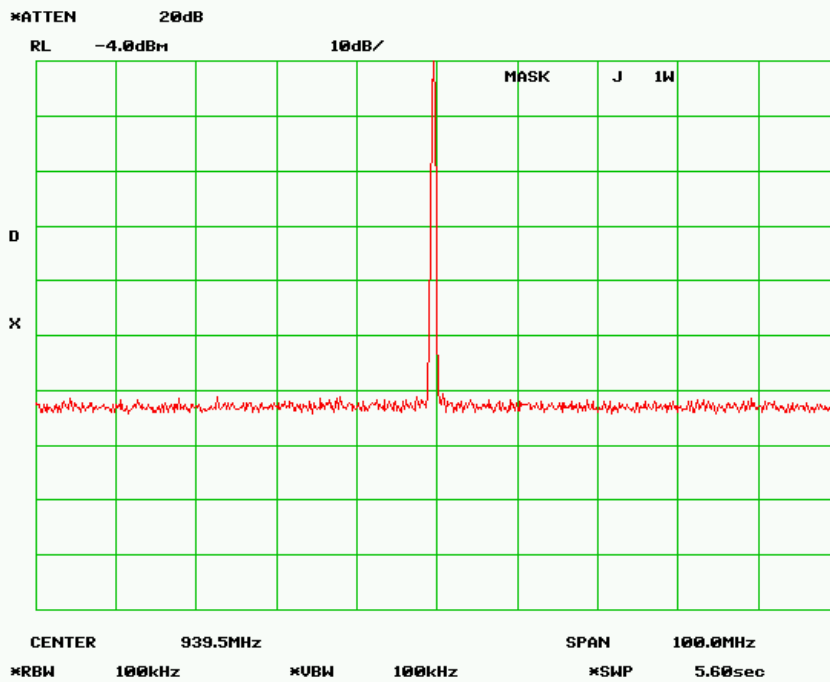
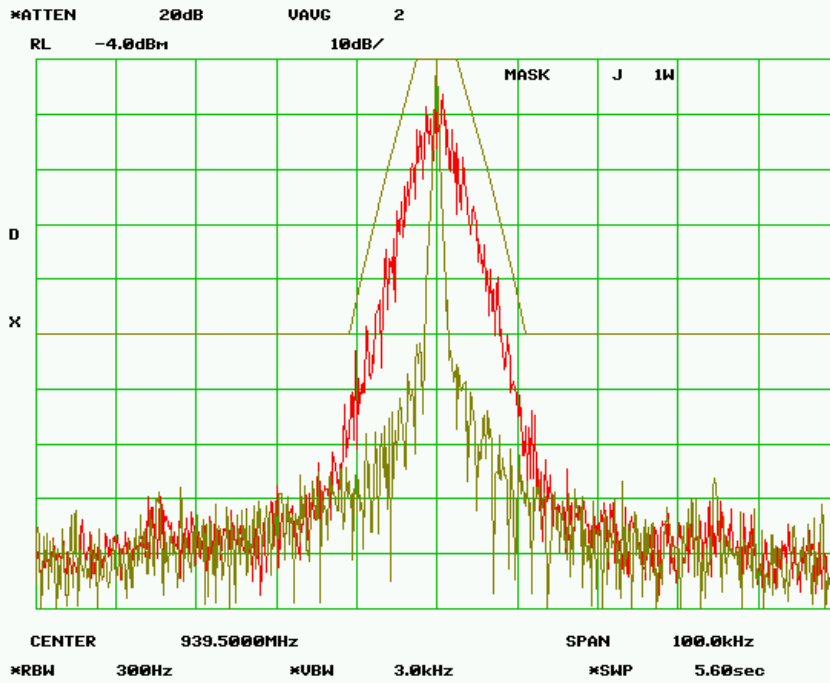

MASK J – 10.0 Watts
RF Frequency 939.500 MHz
SPECTRUM FOR EMISSION - 8K30F1D
Data Rate = 16 kbps
PEAK DEVIATION = 3.70 kHz

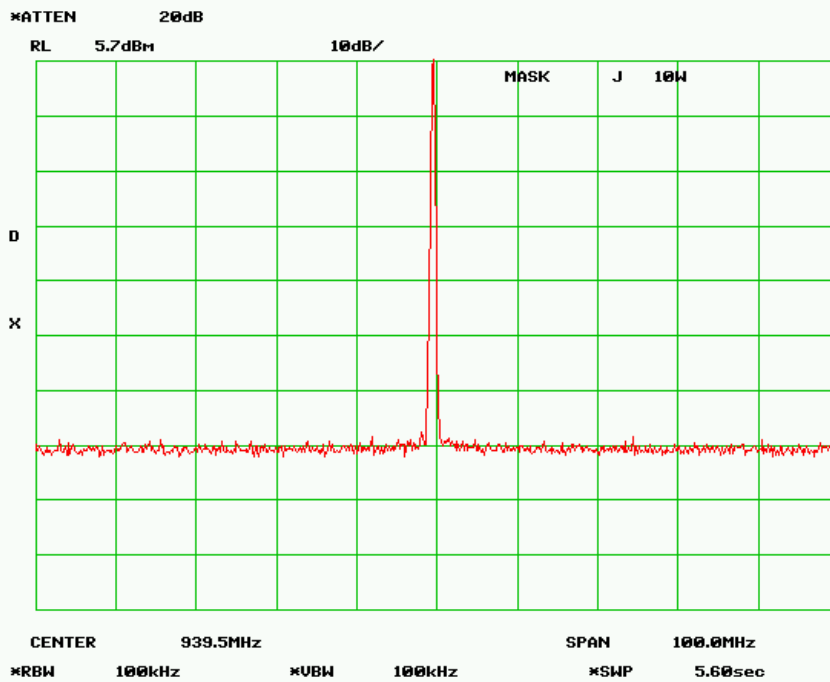
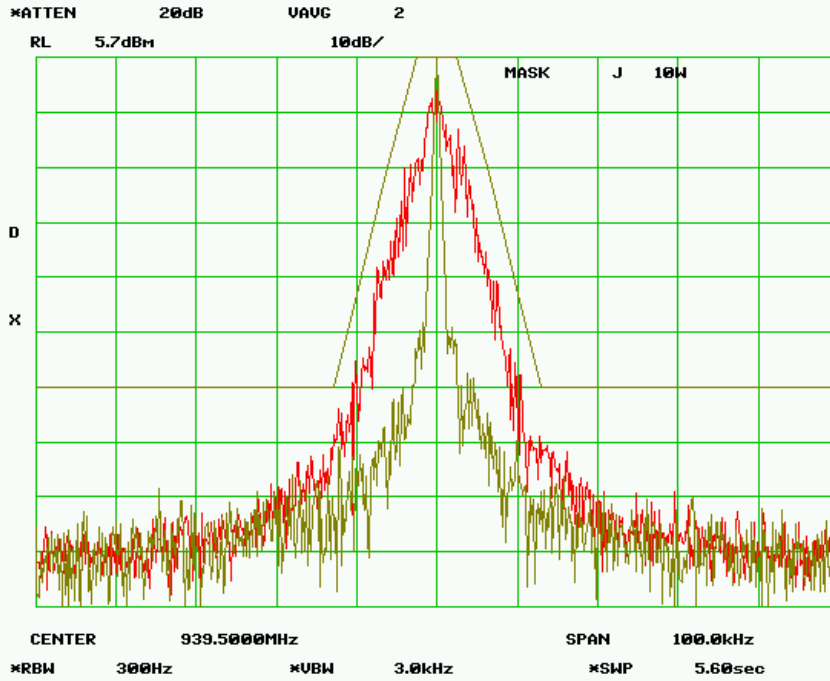

MASK J – 1.0 Watts
RF Frequency 939.500 MHz
SPECTRUM FOR EMISSION - 8K50F1D
Data Rate = 24 kbps
PEAK DEVIATION = 3.725 kHz

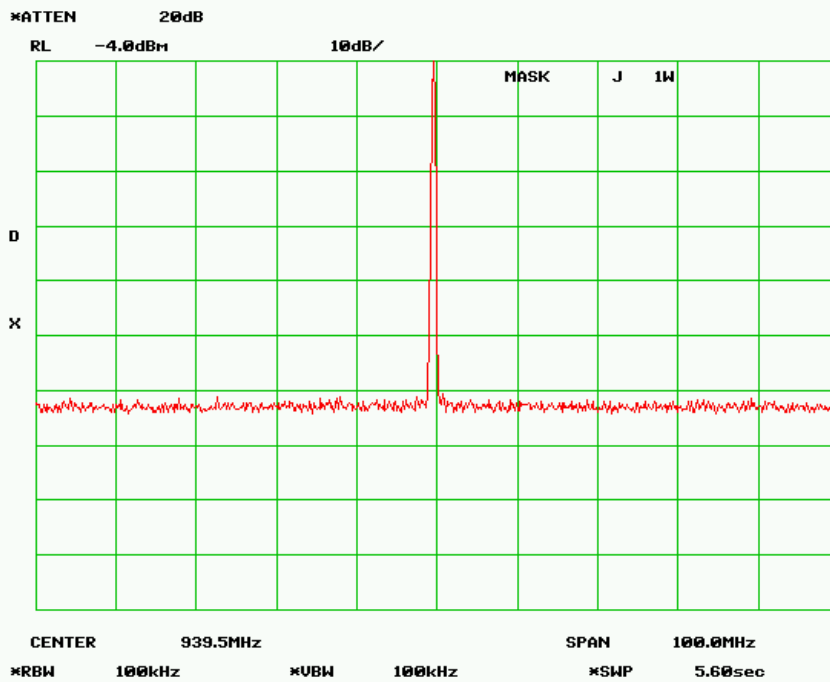
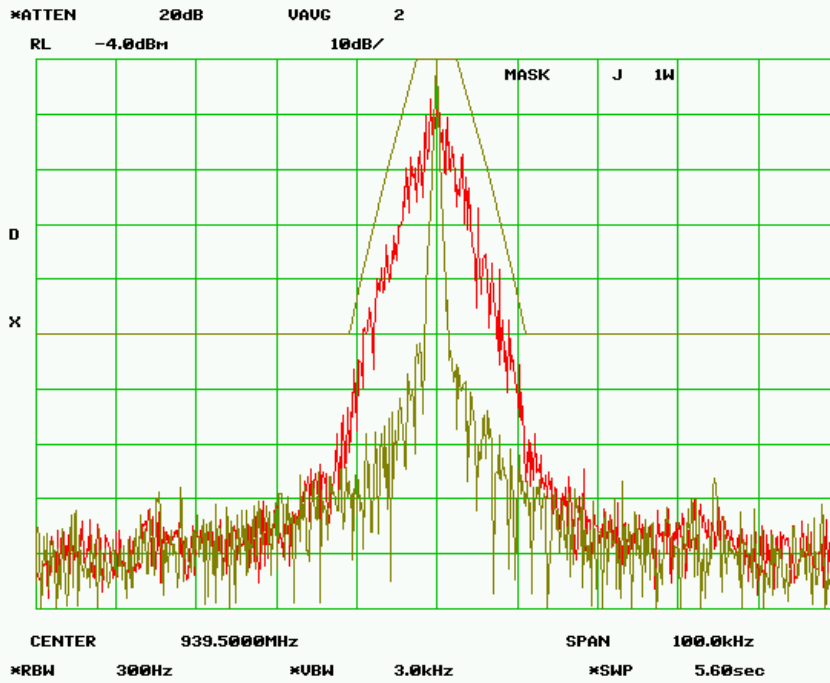

MASK J – 10.0 Watts
RF Frequency 939.500 MHz
SPECTRUM FOR EMISSION - 8K50F1D
Data Rate = 24 kbps
PEAK DEVIATION = 3.725 kHz

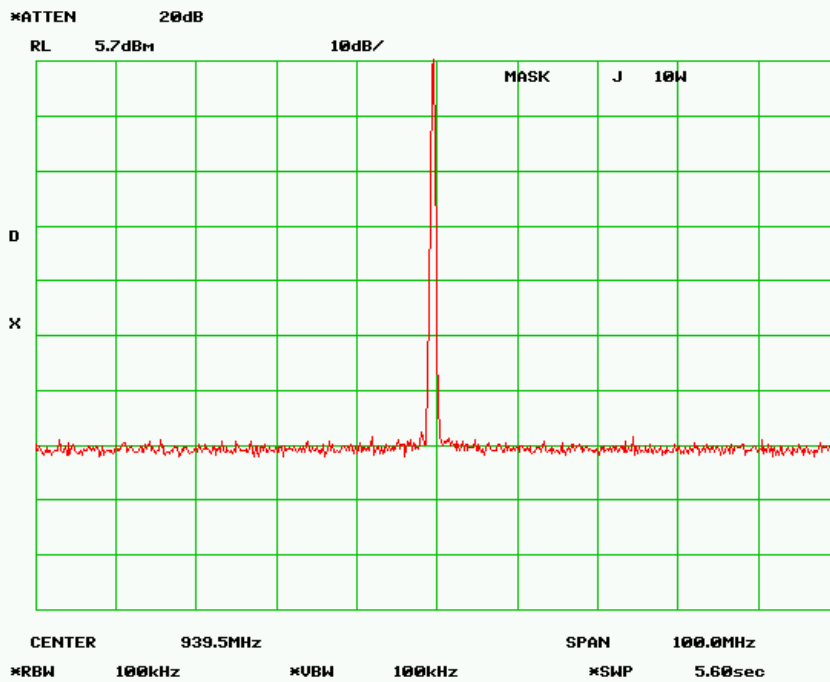
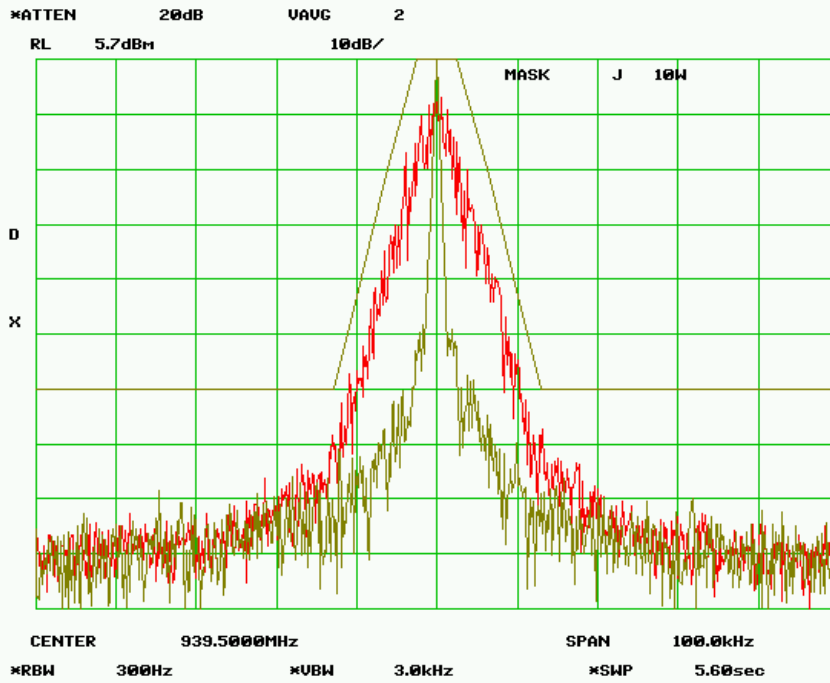

MASK J – 1.0 Watts
RF Frequency 939.500 MHz
SPECTRUM FOR EMISSION - 8K08F1D
Data Rate = 32 kbps
PEAK DEVIATION = 3.728 kHz

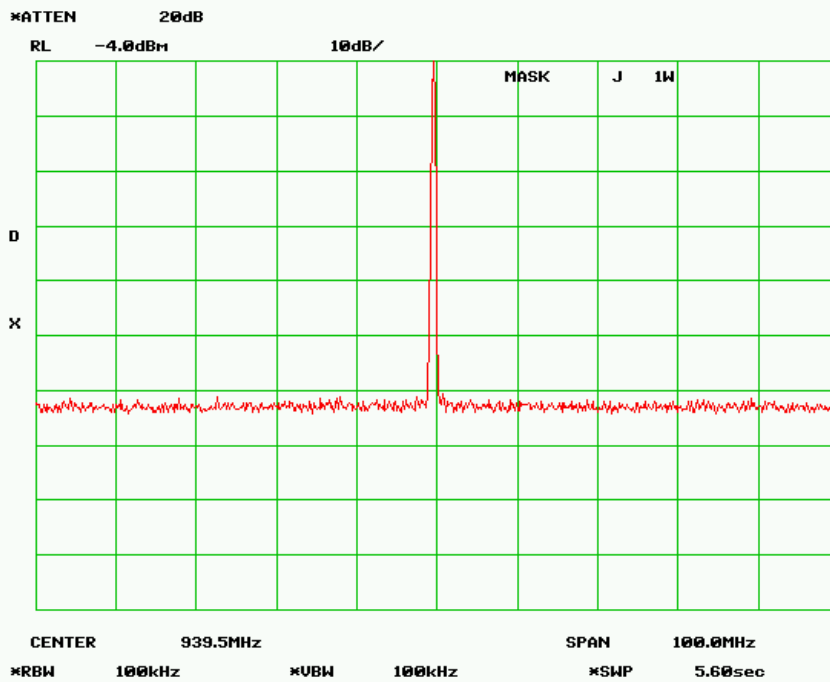
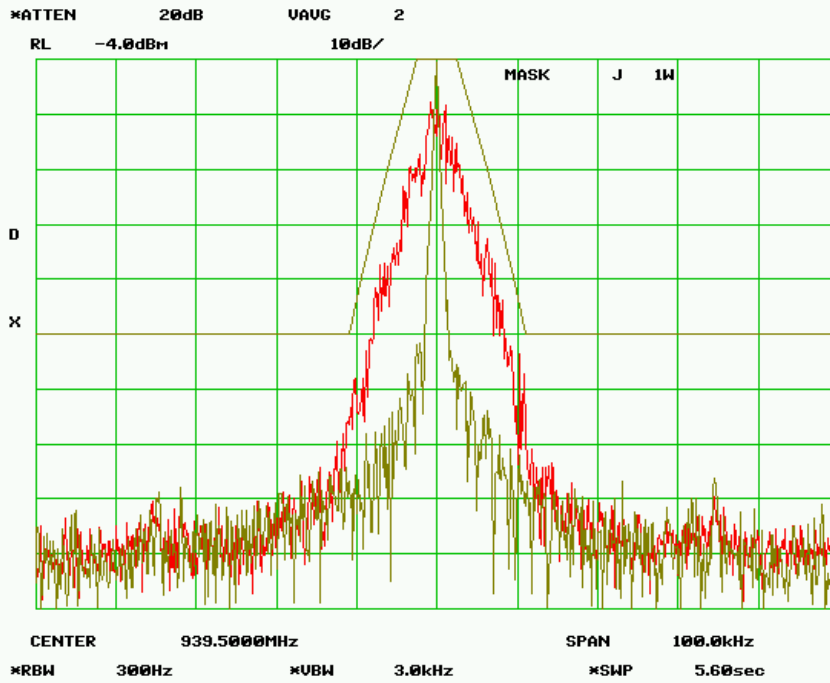

MASK J – 10.0 Watts
RF Frequency 939.500 MHz
SPECTRUM FOR EMISSION - 8K08F1D
Data Rate = 32 kbps
PEAK DEVIATION = 3.728 kHz

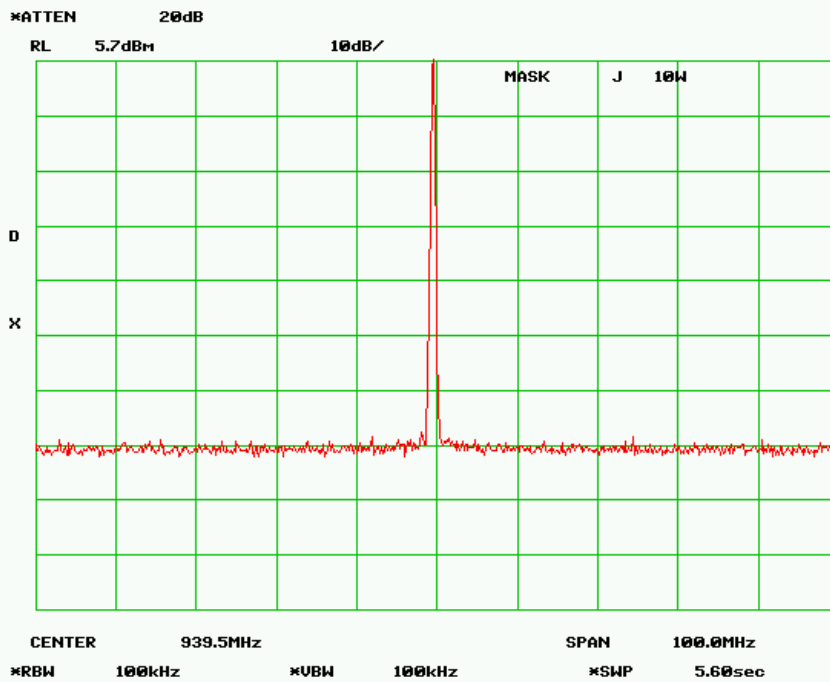
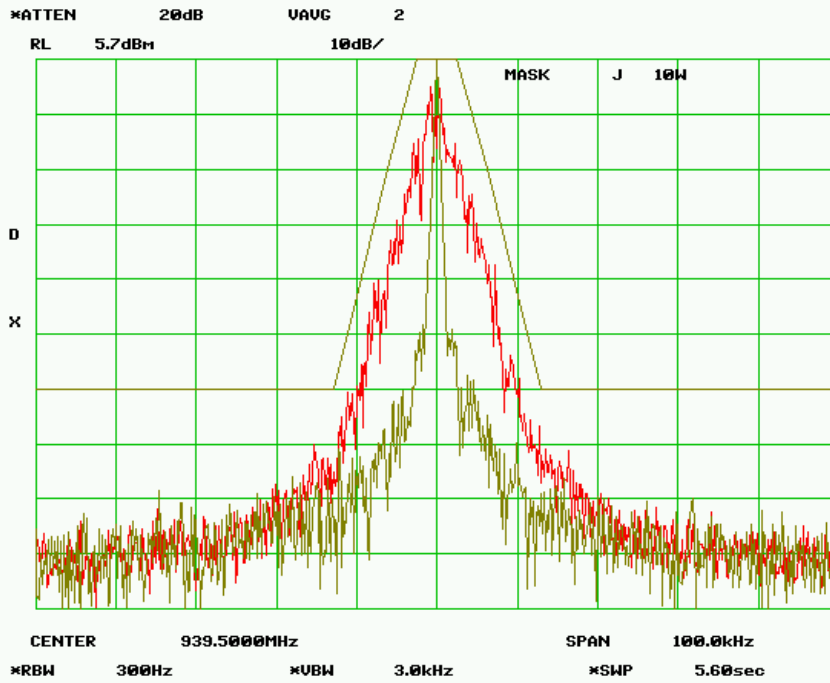

10.0 Mask J – Part 90.210(j) Aggregation for 25 kHz Channel

NAME OF TEST: Transmitter Occupied Bandwidth for Emission Designators
16K5F1D, 16K8F1D, 17K8F1D and 17K0F1D

RULE PART NUMBER: FCC: 2.202, 90.209 (b)(5), 90.210(j), 90.945(h) 2.1049 (c) (1)

MINIMUM STANDARDS: **Mask J**
Sidebands and Spurious [Rule 90.210 (j), P = 10 Watts and P=1 Watt]
Authorized Bandwidth = 13.6 kHz [Rule 90.209(b) (5)]
Fo of more than 2.5 kHz, but no more than 6.25 kHz: At least $53 \log (f_d / 2.5)$ dB
Fo of more than 6.25 kHz, but no more than 9.5 kHz: At least $103 \log (f_d / 3.9)$ dB;
Fo of more than 9.5 kHz: At least $157 \log (f_d / 5.3)$ dB, or $50 + 10 \log (P)$ dB or 70 dB, whichever is the lesser attenuation.

Part 90.645(h) allows for aggregating contiguous channels.

16K5F1D	3 contiguous channels
16K8F1D	3 contiguous channels
17K8F1D	3 contiguous channels
17K0F1D	3 contiguous channels

For emission designators 16K5F1D, 16K8F1D, 17K8F1D and 17K0F1D. The limits are derived by adding $2 \times (6.25 \text{ kHz}) = 12.5 \text{ kHz}$ to each of the original limits.

Attenuation = 0 dB at Fo to 15 kHz
Attenuation = 21.0 dB at 18.75 kHz
Attenuation = 22.0 at 39.8 kHz
Attenuation = 60 dB at frequencies greater than 25.3 kHz @ 10 W
Attenuation = 50 dB at frequencies greater than 23.5 kHz @ 1 W

TEST RESULTS: Meets minimum standards (see data on following page)

TEST CONDITIONS: Standard Test Conditions, 25 C
RF Power Level = 1 Watt and 10 Watts
Voltage = 20VDC

TEST PROCEDURE: TIA/EIA – 603-C, 2.2.13, 3.2.11.2

TEST EQUIPMENT: 50-Ohm Attenuator, Bird Electronics Model 50-A-FFN-20 (20dB, 50W)
50-Ohm Attenuator, Bird Electronics Model 10-A-MFN-10 (10dB, 10W)
50-Ohm Attenuator, Pasternack Model PE7002-10 (10dB)
DC Power Supply, Hewlett Packard Model 6653A
Spectrum Analyzer, Hewlett Packard Model HP8563E
Modulation Analyzer, Hewlett Packard Model HP8901A

TEST SET-UP:

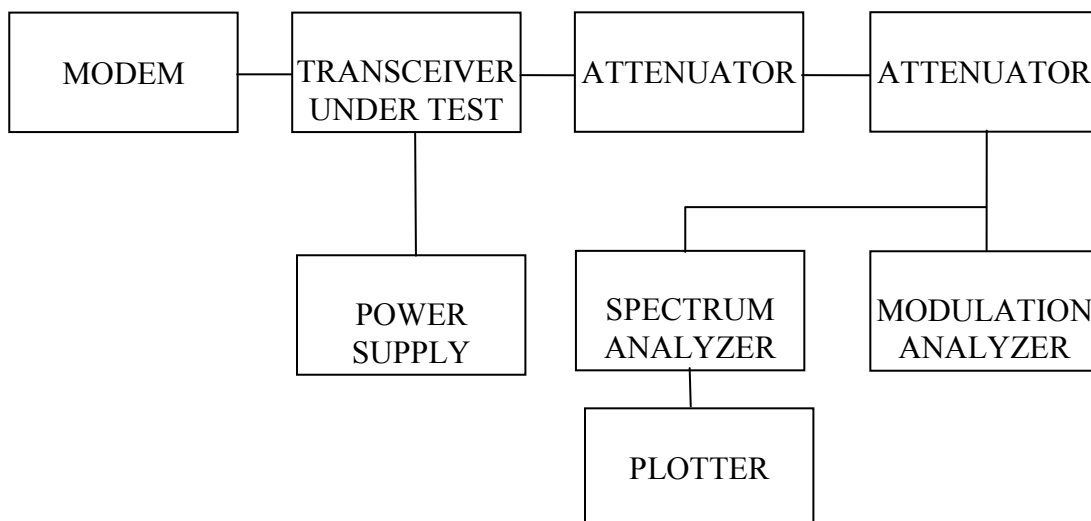

MASK J - 25 kHz - 1.0 Watts
RF Frequency 939.500 MHz
SPECTRUM FOR EMISSION - 16K5F1D
Data Rate = 16 kbps
PEAK DEVIATION = 6.30 kHz

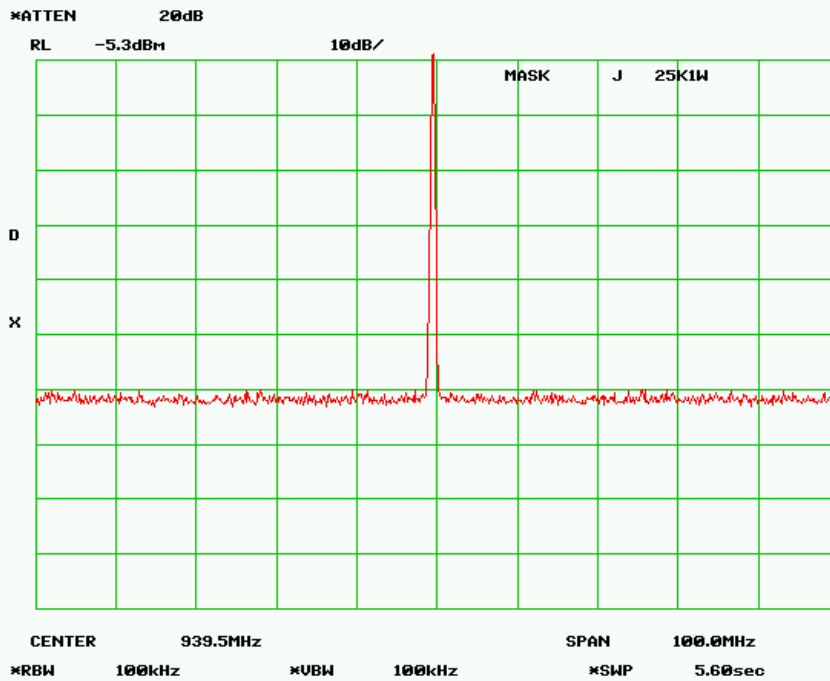
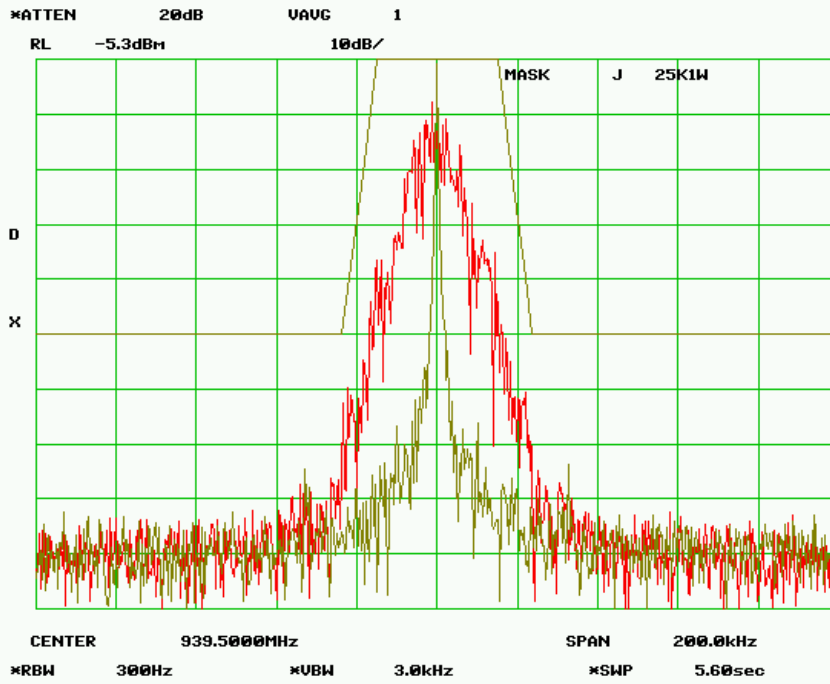

MASK J - 25 kHz - 10.0 Watts
RF Frequency 939.500 MHz
SPECTRUM FOR EMISSION - 16K5F1D
Data Rate = 16 kbps
PEAK DEVIATION = 6.30 kHz

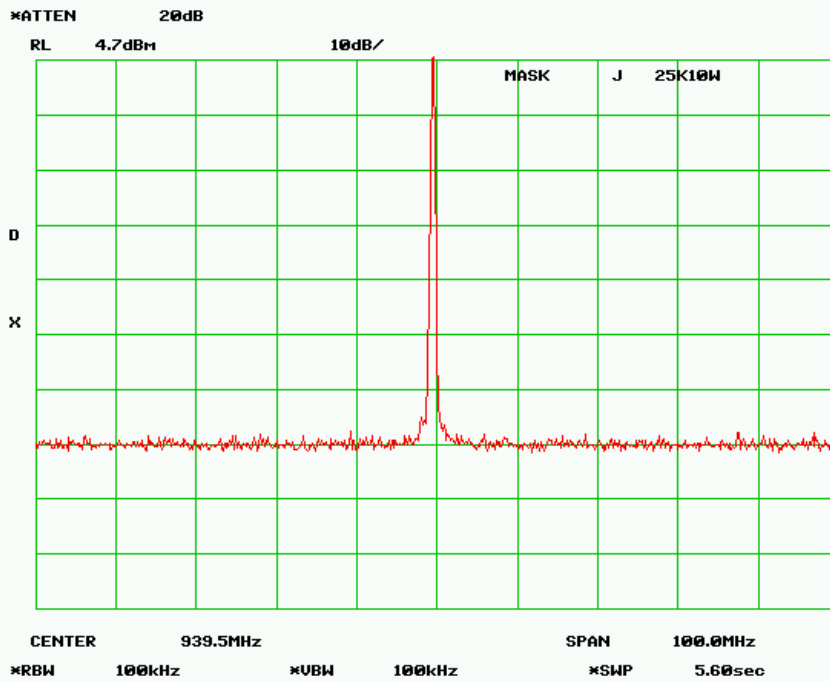
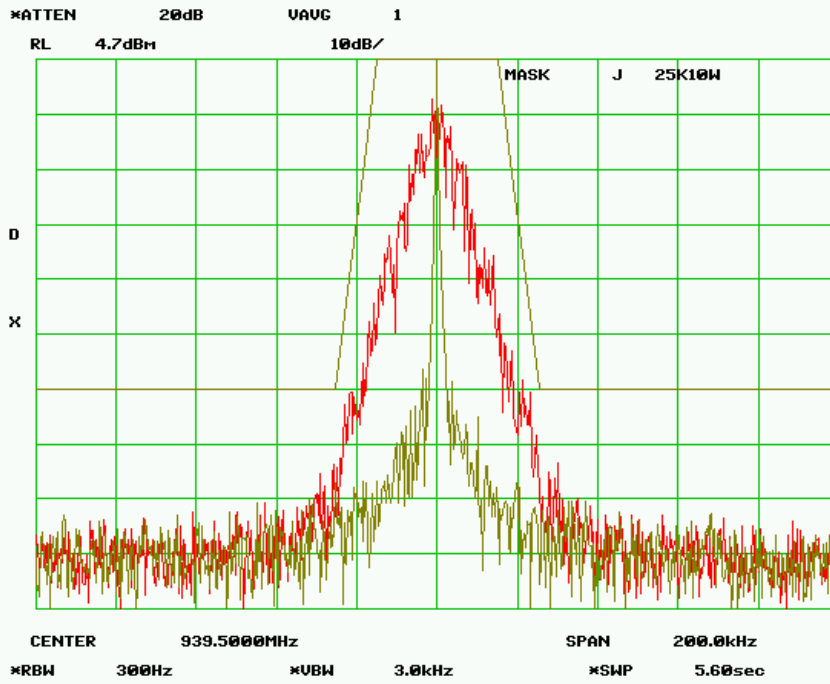

MASK J - 25 kHz - 1.0 Watts
RF Frequency 939.500 MHz
SPECTRUM FOR EMISSION - 16K8F1D
Data Rate = 32 kbps
PEAK DEVIATION = 6.30 kHz

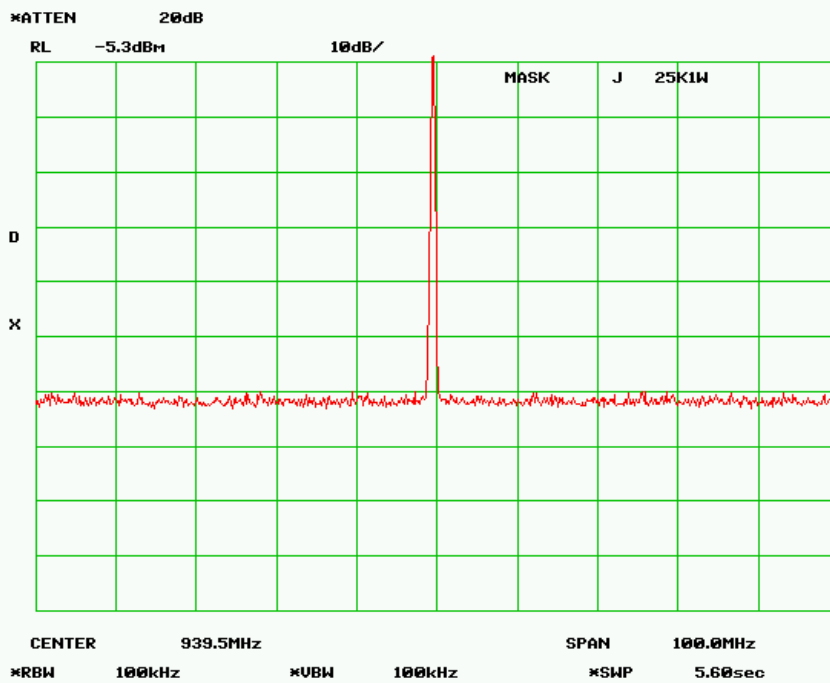
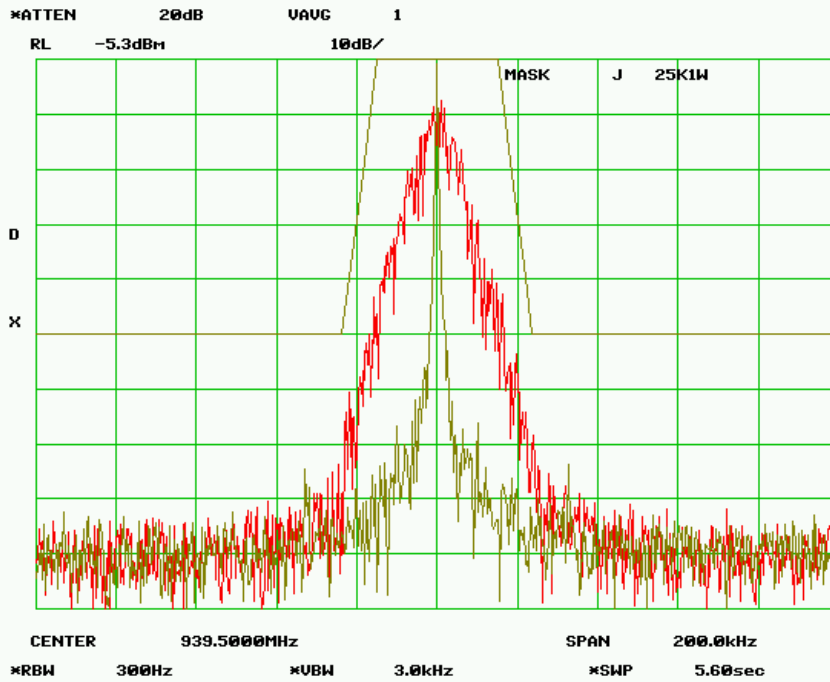

MASK J - 25 kHz - 10.0 Watts
RF Frequency 939.500 MHz
SPECTRUM FOR EMISSION - 16K8F1D
Data Rate = 32 kbps
PEAK DEVIATION = 6.30 kHz

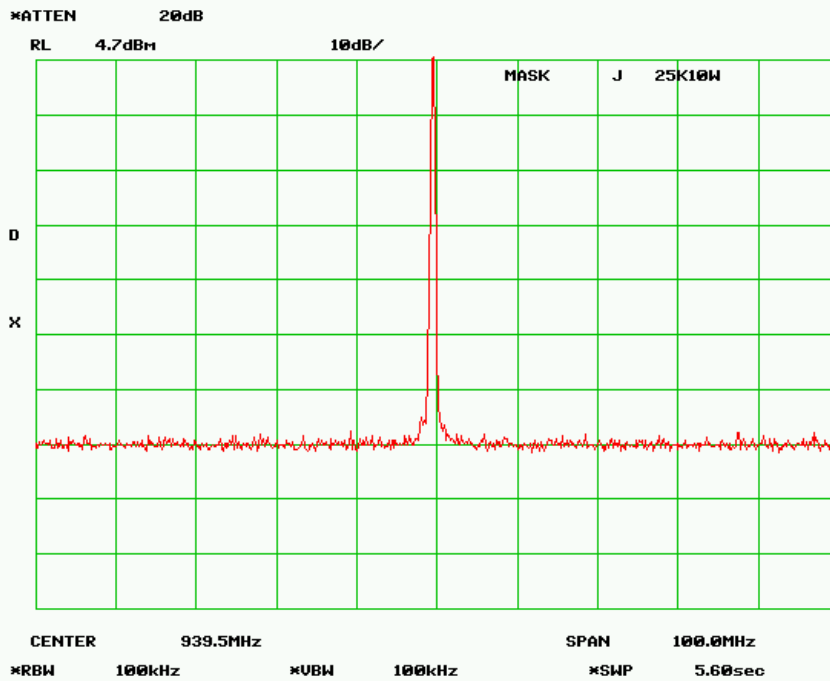
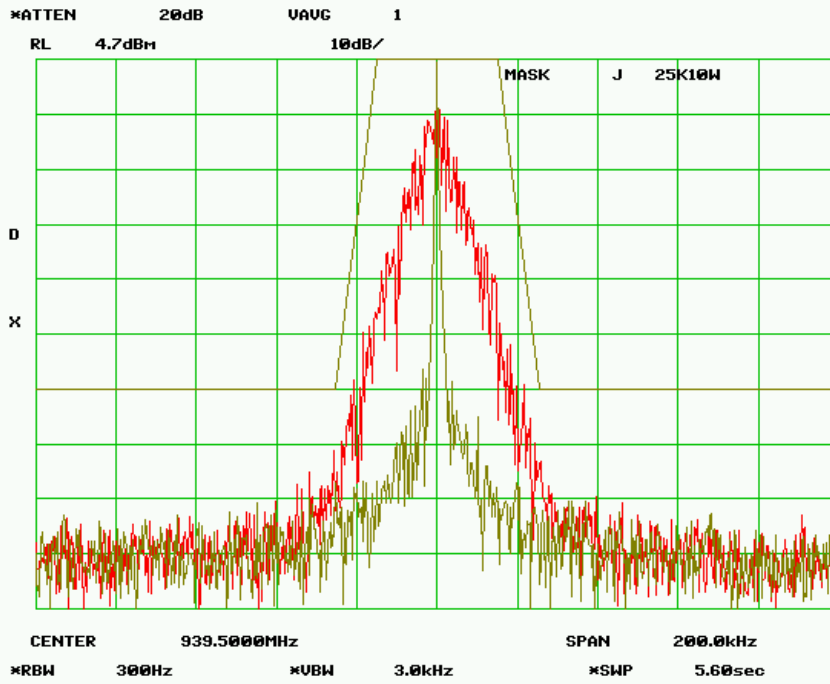

MASK J - 25 kHz - 1.0 Watts
RF Frequency 939.500 MHz
SPECTRUM FOR EMISSION - 17K8F1D
Data Rate = 48 kbps
PEAK DEVIATION = 7.59 kHz

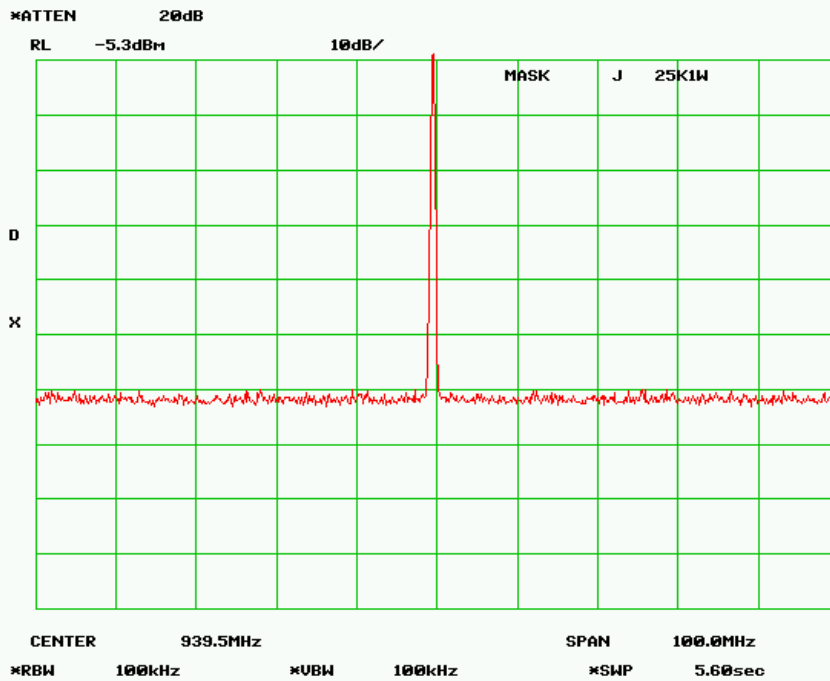
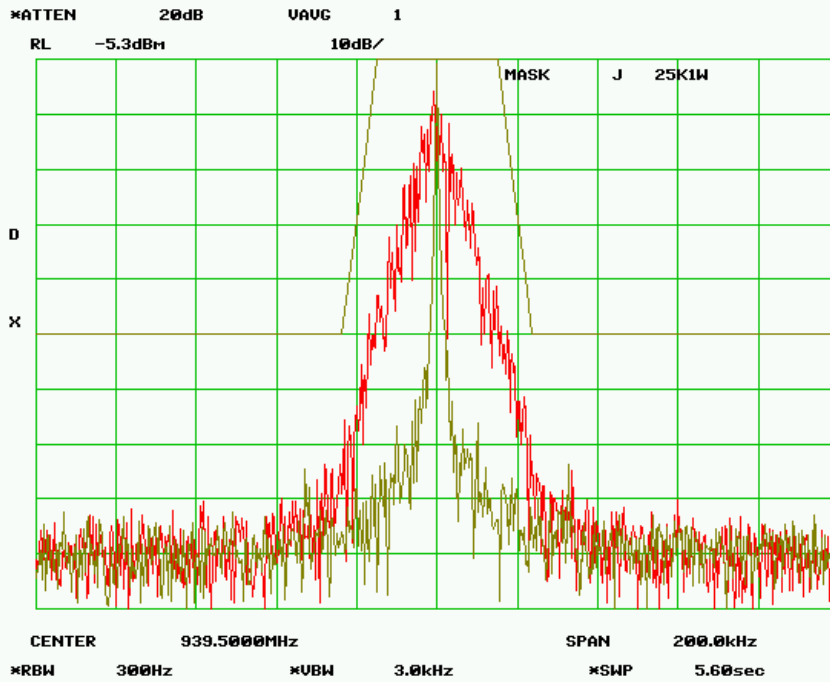

MASK J - 25 kHz - 10.0 Watts
RF Frequency 939.500 MHz
SPECTRUM FOR EMISSION - 17K8F1D
Data Rate = 48 kbps
PEAK DEVIATION = 7.59 kHz

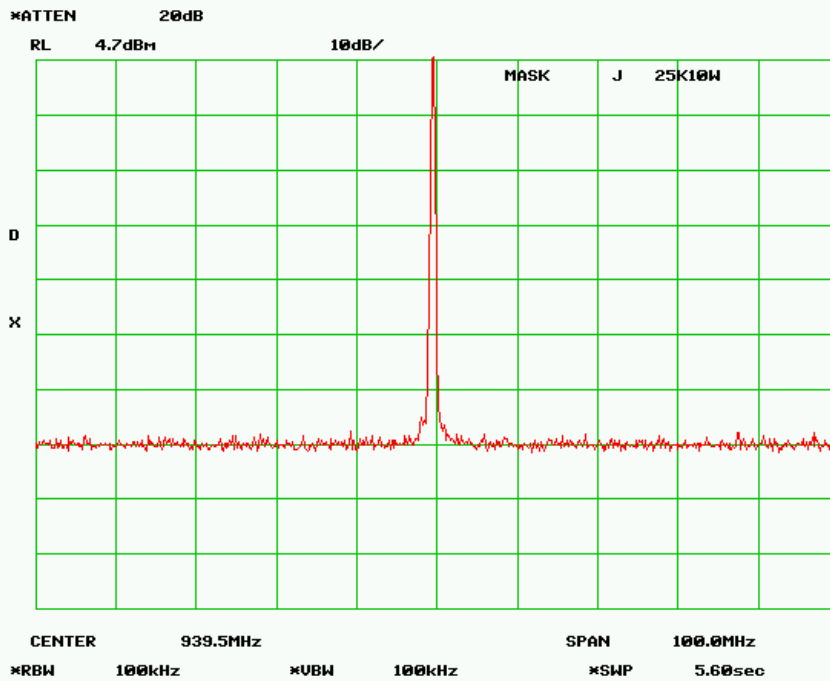
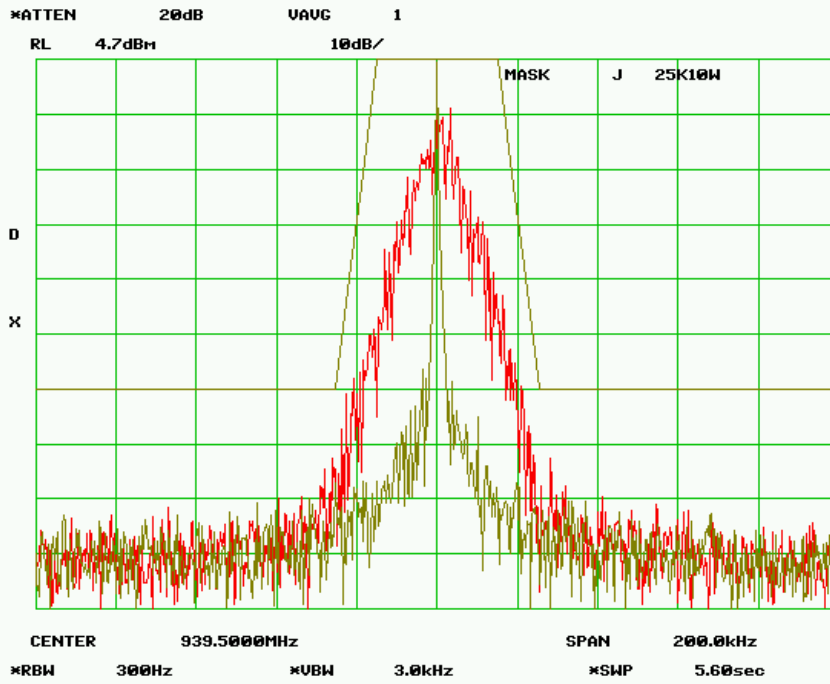

MASK J - 25 kHz - 1.0 Watts
RF Frequency 939.500 MHz
SPECTRUM FOR EMISSION - 17K0F1D
Data Rate = 64 kbps
PEAK DEVIATION = 7.52 kHz

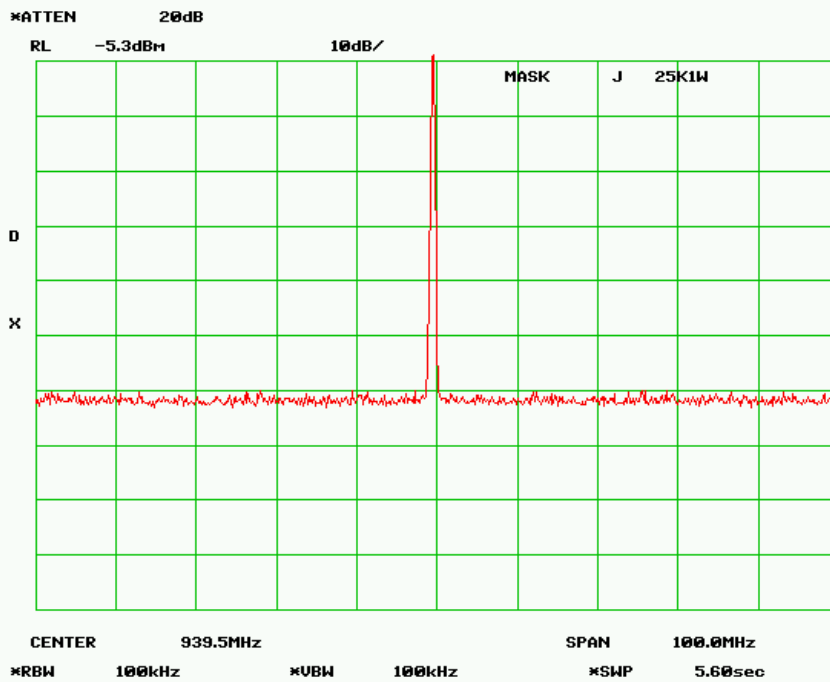
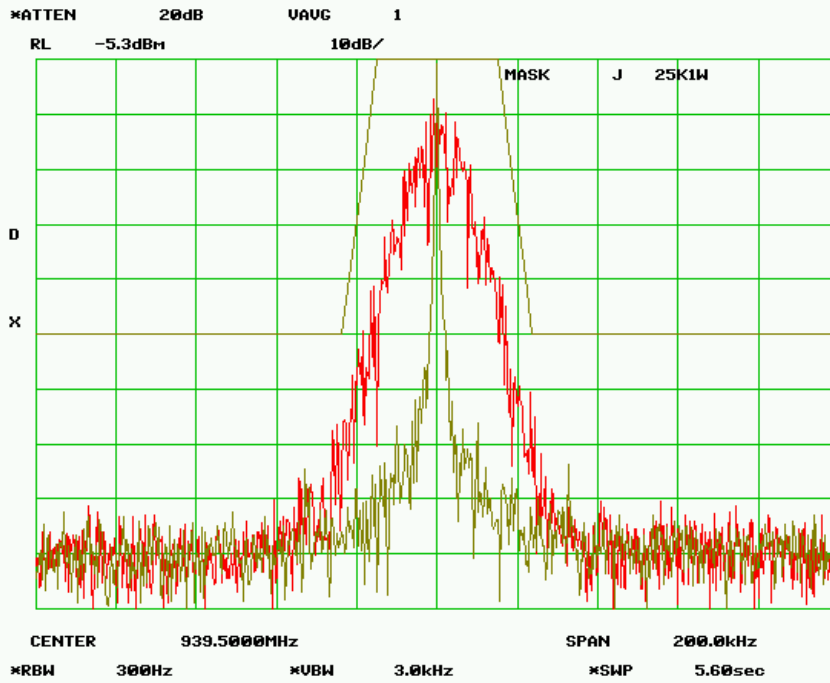

MASK J - 25 kHz - 10.0 Watts
RF Frequency 939.500 MHz
SPECTRUM FOR EMISSION - 17K0F1D
Data Rate = 64 kbps
PEAK DEVIATION = 7.52 kHz

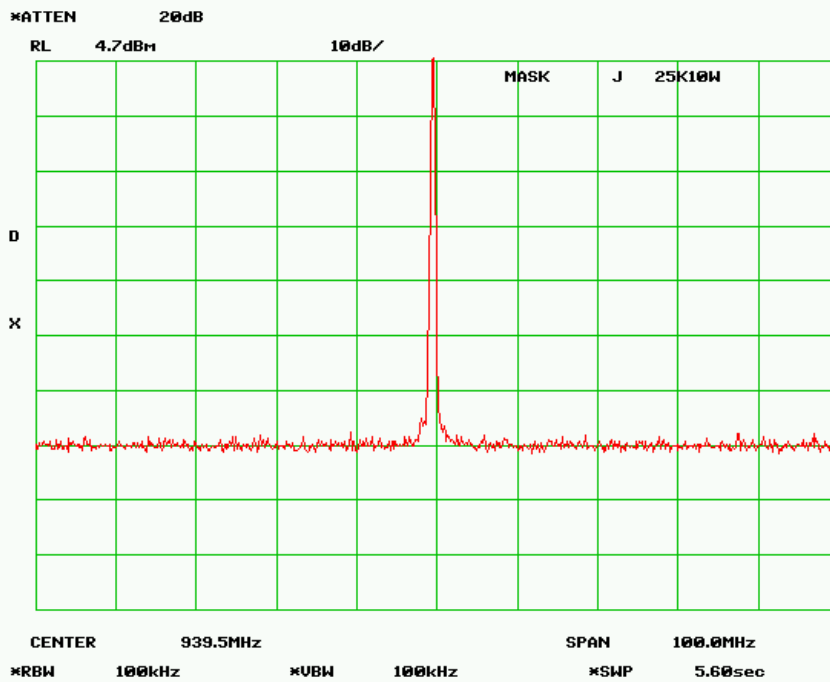
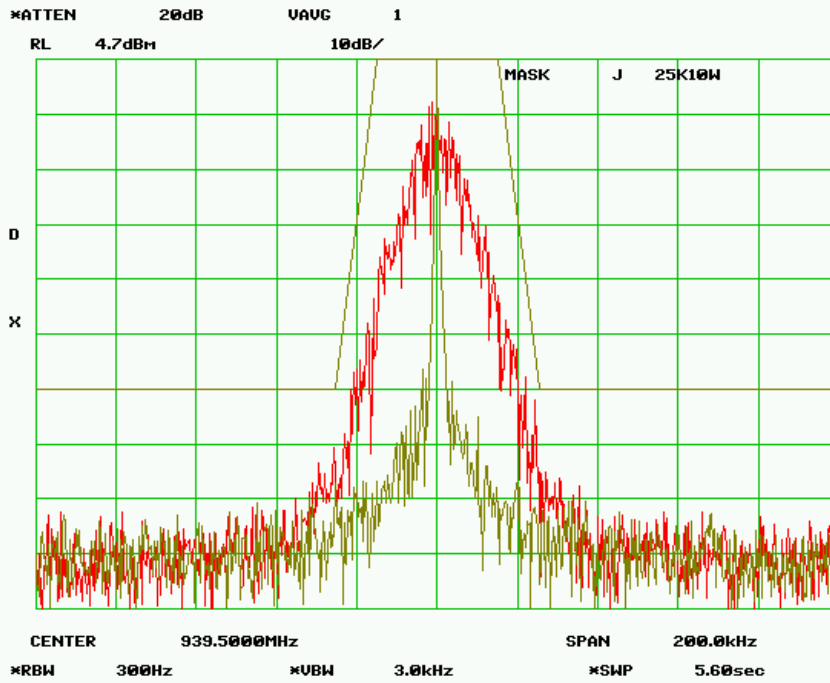

11.0 Mask J – Part 90.210(j) Aggregation for 50 kHz Channel

NAME OF TEST: Transmitter Occupied Bandwidth for Emission Designators
29K8F1D, 30K0F1D, 29K5F1D, 30K5F1D

RULE PART NUMBER: FCC: 2.202, 90.209 (b)(5), 90.210(j), 90.945(h) 2.1049 (c) (1)

MINIMUM STANDARDS: **Mask J**
 Sidebands and Spurious [Rule 90.210 (j), P = 10 Watts and P=1 Watt]
 Authorized Bandwidth = 13.6 kHz [Rule 90.209(b) (5)]
 Fo of more than 2.5 kHz, but no more than 6.25 kHz: At least 53 log (f_d/2.5) dB
 Fo of more than 6.25 kHz, but no more than 9.5 kHz: At least 103 log (f_d/3.9) dB;
 Fo of more than 9.5 kHz: At least 157 log (f_d/5.3) dB, or 50 + 10 log (P) dB or 70 dB,
 whichever is the lesser attenuation.

Part 90.645(h) allows for aggregating contiguous channels.

29K8F1D	5 contiguous channels
30K0F1D	5 contiguous channels
29K5F1D	5 contiguous channels
30K5F1D	5 contiguous channels

For emission designators 29K8F1D, 30K0F1D, 29K5F1D, 30K5F1D. The limits are derived by adding 4*(6.25 kHz) = 25.0 kHz to each of the original limits.

Attenuation = 0 dB at Fo to 27.5 kHz
 Attenuation = 21.0 dB at 31.25 kHz
 Attenuation = 22.0 at 34.5 kHz
 Attenuation = 60 dB at frequencies greater than 37.8 kHz @ 10 W
 Attenuation = 50 dB at frequencies greater than 36.0 kHz @ 1 W

TEST RESULTS: Meets minimum standards (see data on following page)

TEST CONDITIONS: Standard Test Conditions, 25 C
 RF Power Level = 1 Watt and 10 Watts
 Voltage = 20VDC

TEST PROCEDURE: TIA/EIA – 603-C, 2.2.13, 3.2.11.2

TEST EQUIPMENT: 50-Ohm Attenuator, Bird Electronics Model 50-A-FFN-20 (20dB, 50W)
 50-Ohm Attenuator, Bird Electronics Model 10-A-MFN-10 (10dB, 10W)
 50-Ohm Attenuator, Pasternack Model PE7002-10 (10dB)
 DC Power Supply, Hewlett Packard Model 6653A
 Spectrum Analyzer, Hewlett Packard Model HP8563E
 Modulation Analyzer, Hewlett Packard Model HP8901A

TEST SET-UP:

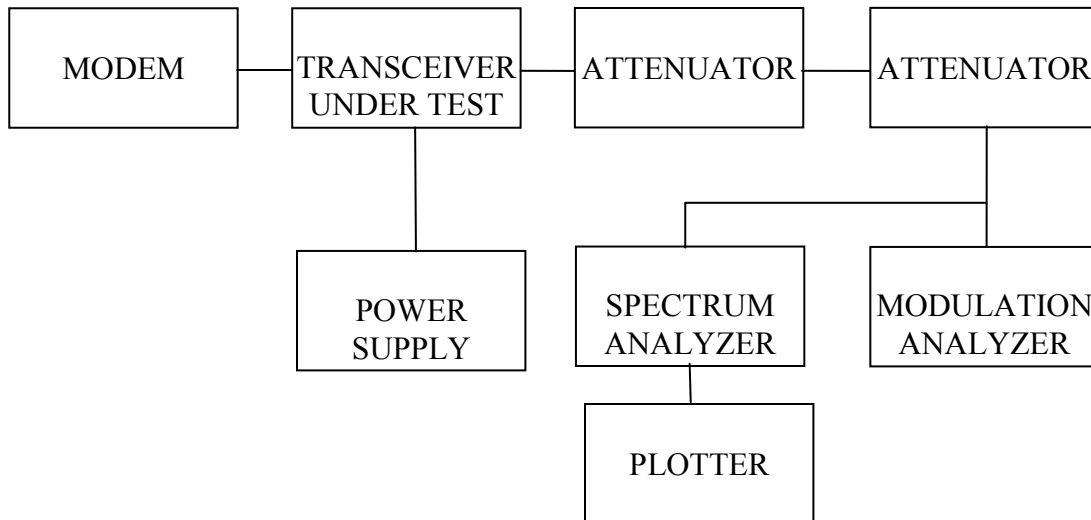

MASK J - 50 kHz - 1.0 Watts
RF Frequency 939.500 MHz
SPECTRUM FOR EMISSION - 29K8F1D
 Data Rate = 32 kbps
 PEAK DEVIATION = 9.36 kHz

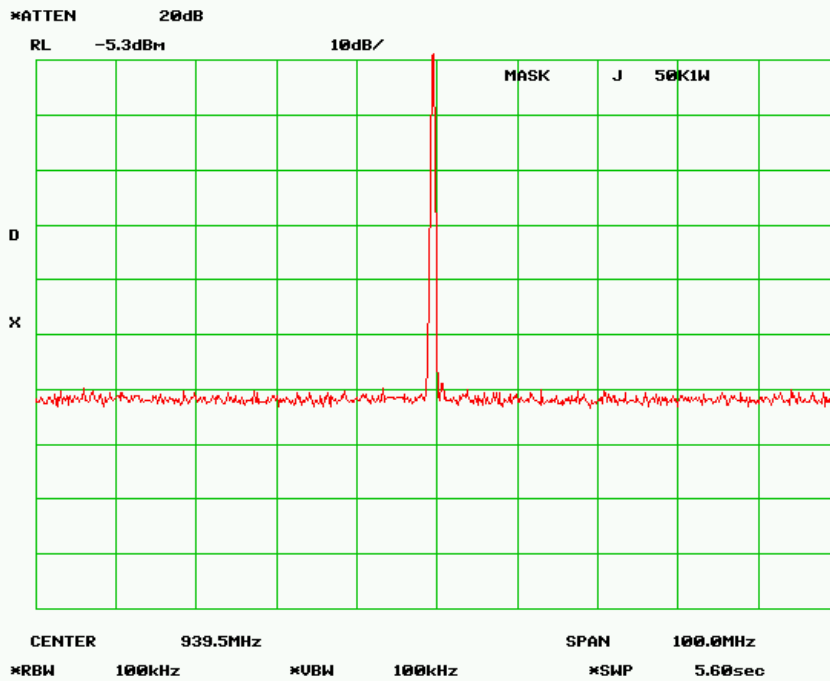
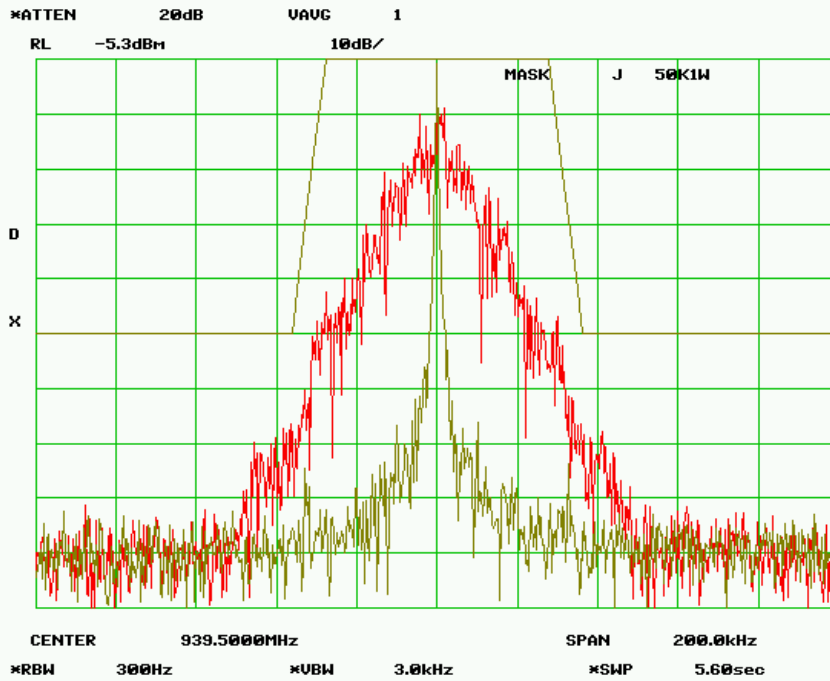

MASK J - 50 kHz - 10.0 Watts
RF Frequency 939.500 MHz
SPECTRUM FOR EMISSION - 29K8F1D
Data Rate = 32 kbps
PEAK DEVIATION = 9.36 kHz

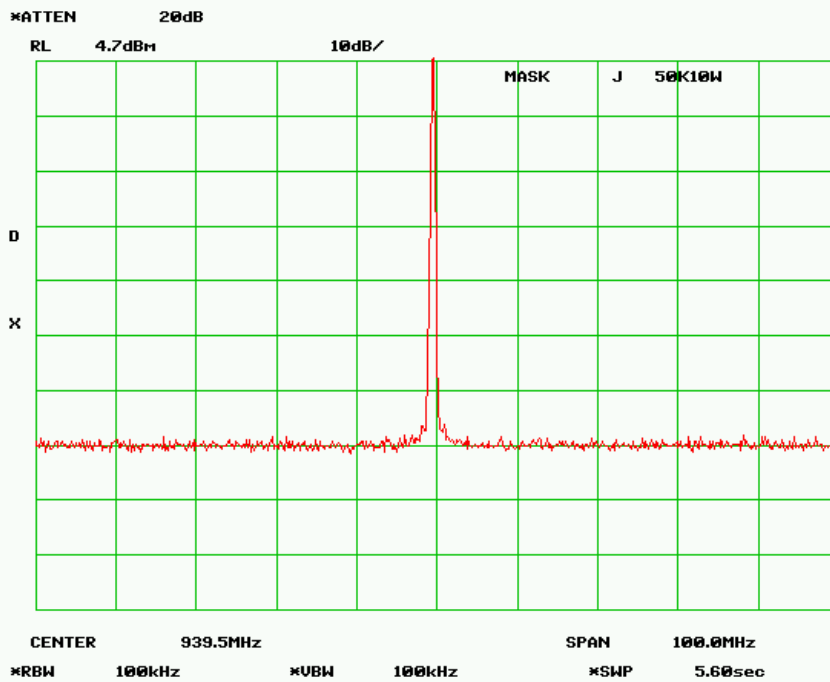
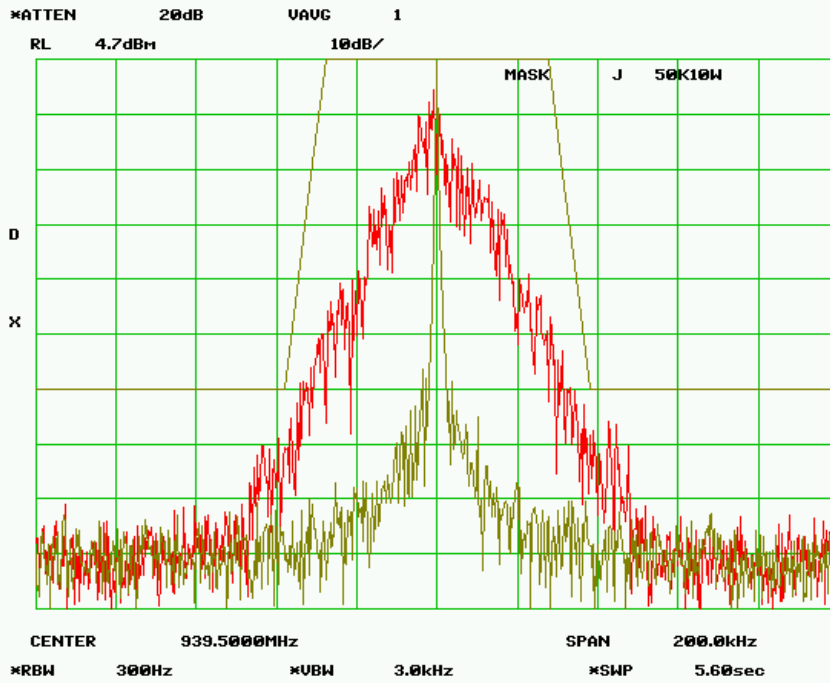

MASK J - 50 kHz - 1.0 Watts
RF Frequency 939.500 MHz
SPECTRUM FOR EMISSION - 30K0F1D
Data Rate = 64 kbps
PEAK DEVIATION = 11.02 kHz

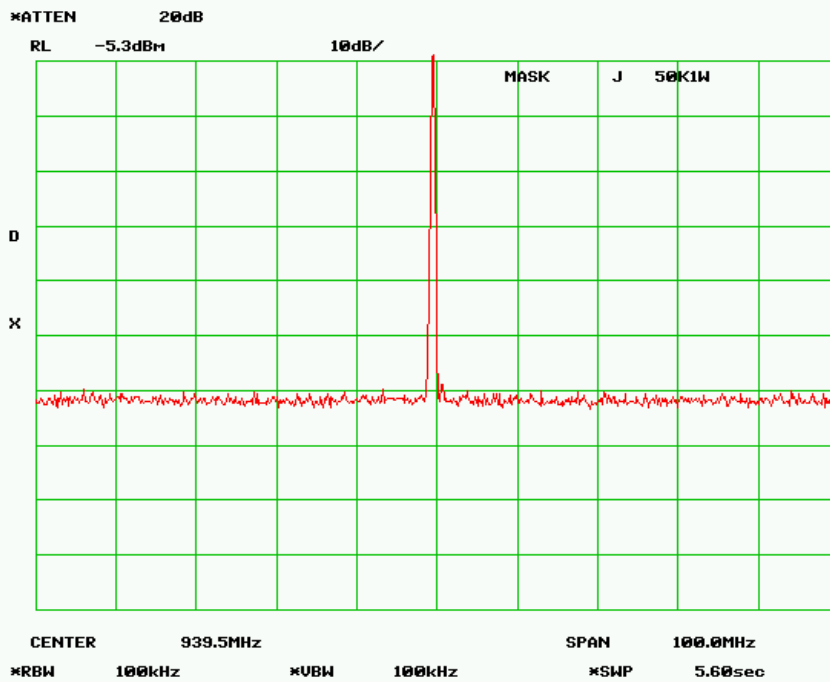
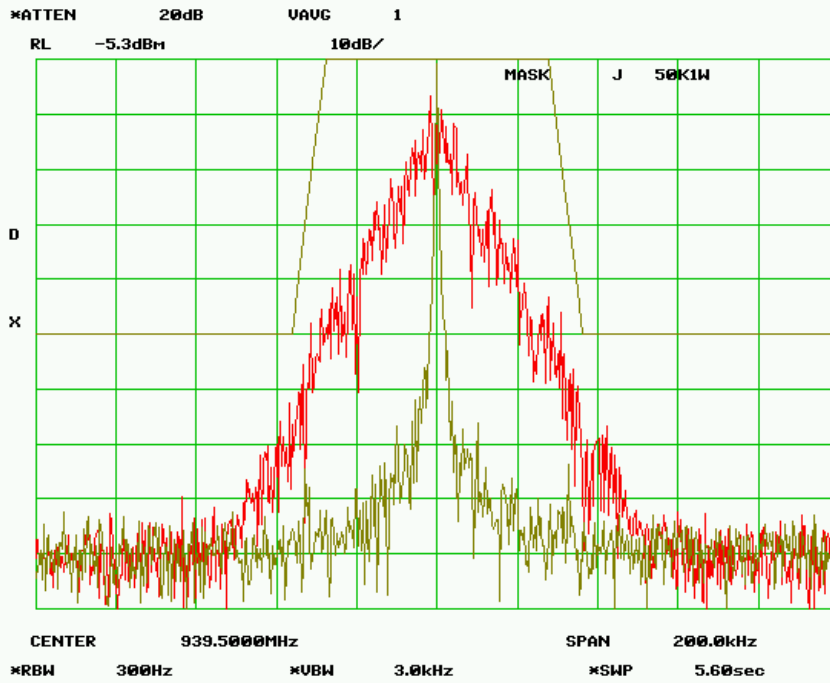

MASK J - 50 kHz - 10.0 Watts
RF Frequency 939.500 MHz
SPECTRUM FOR EMISSION - 30K0F1D
Data Rate = 64 kbps
PEAK DEVIATION = 11.02 kHz

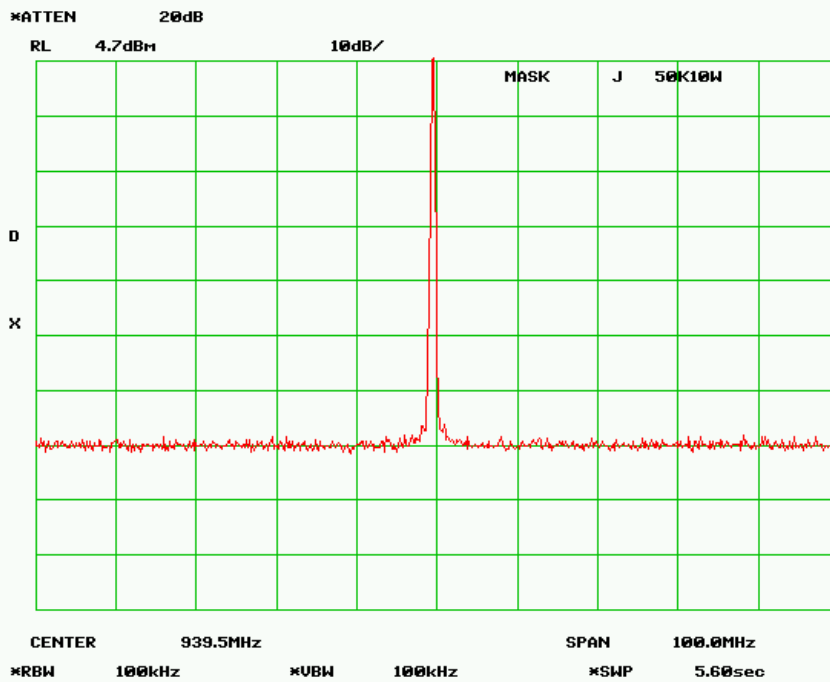
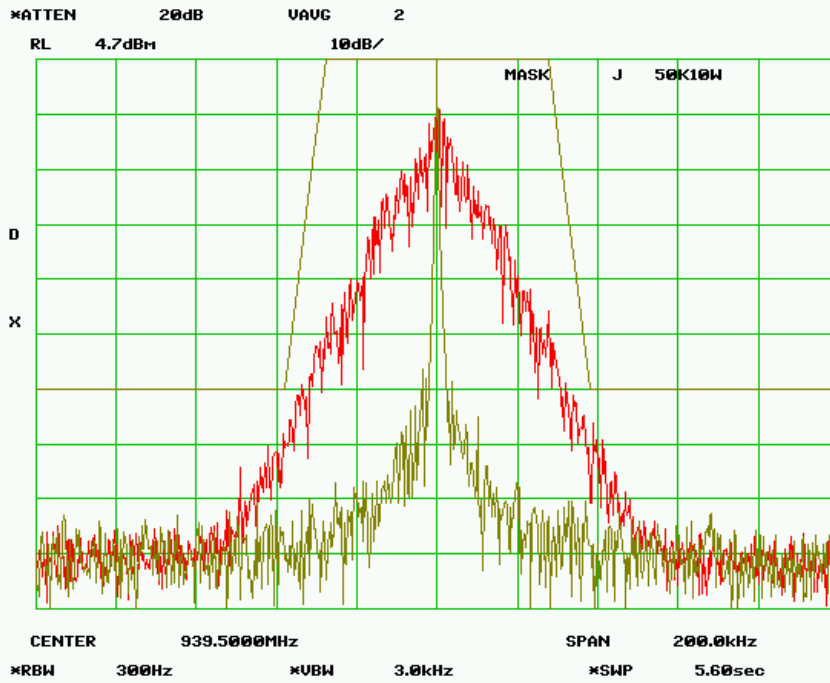

MASK J - 50 kHz - 1.0 Watts
RF Frequency 939.500 MHz
SPECTRUM FOR EMISSION - 29K5F1D
Data Rate = 96 kbps
PEAK DEVIATION = 10.81 kHz

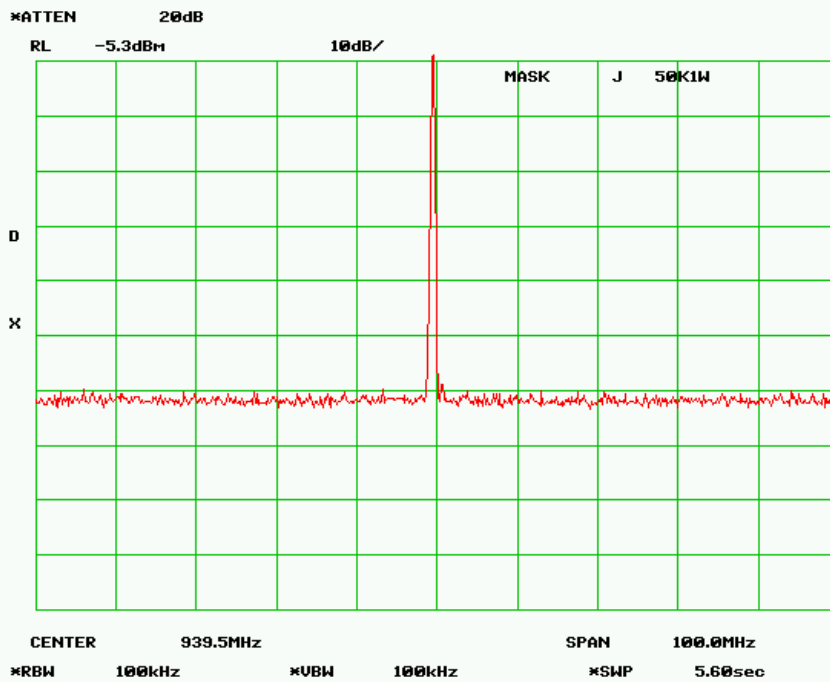
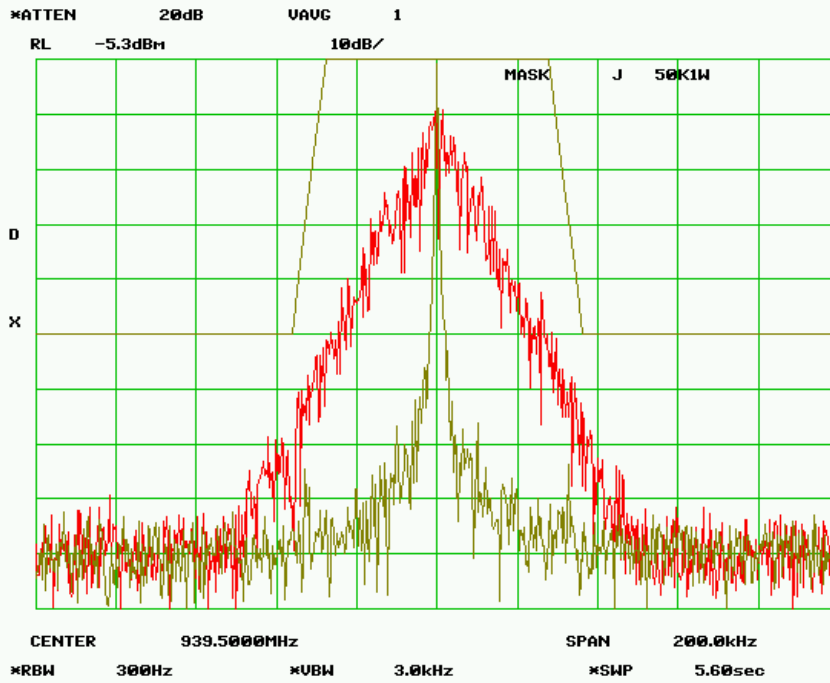

MASK J - 50 kHz - 10.0 Watts
RF Frequency 939.500 MHz
SPECTRUM FOR EMISSION - 29K5F1D
 Data Rate = 96 kbps
 PEAK DEVIATION = 10.81 kHz

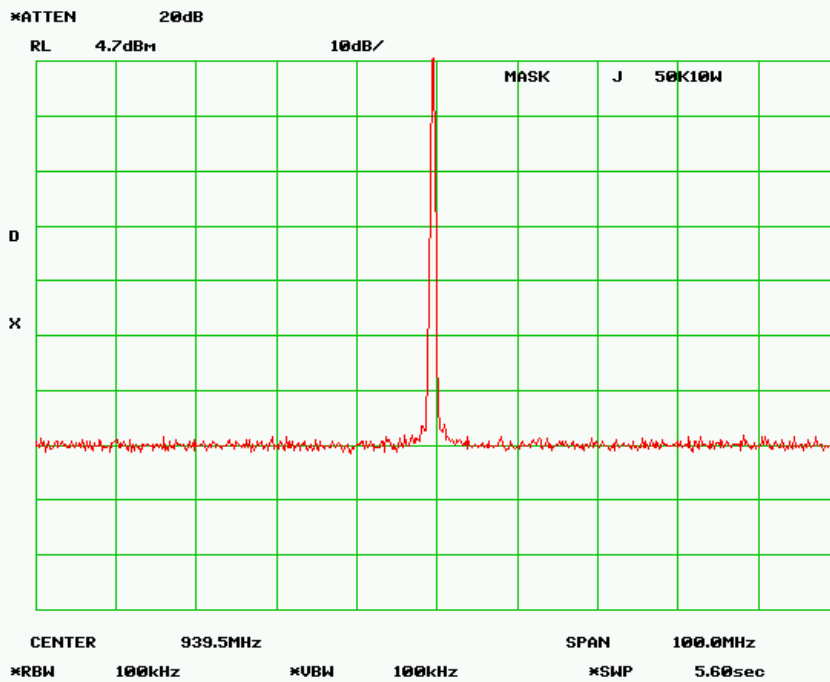
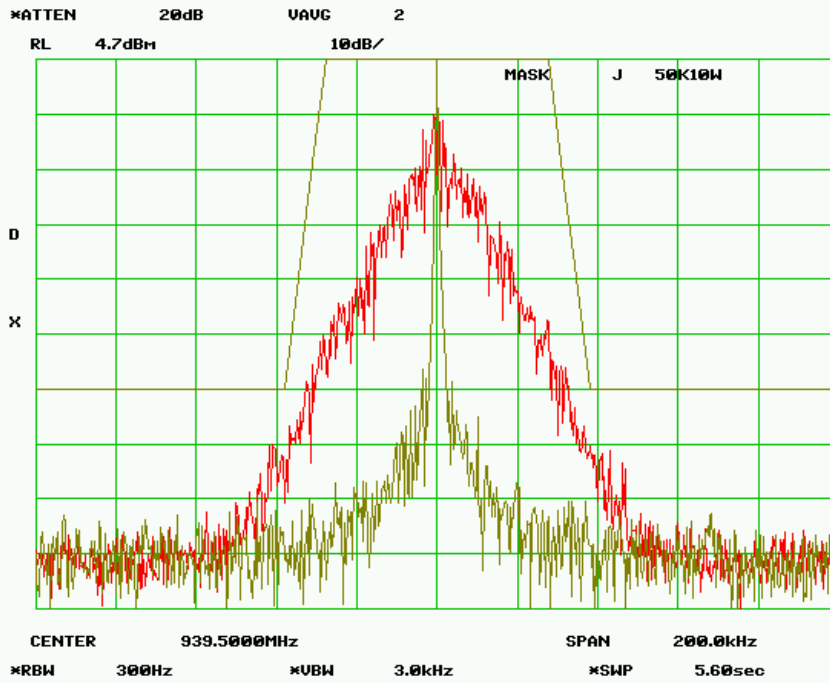

MASK J - 50 kHz - 1.0 Watts
RF Frequency 939.500 MHz
SPECTRUM FOR EMISSION - 30K5F1D
Data Rate = 128 kbps
PEAK DEVIATION = 11.66 kHz

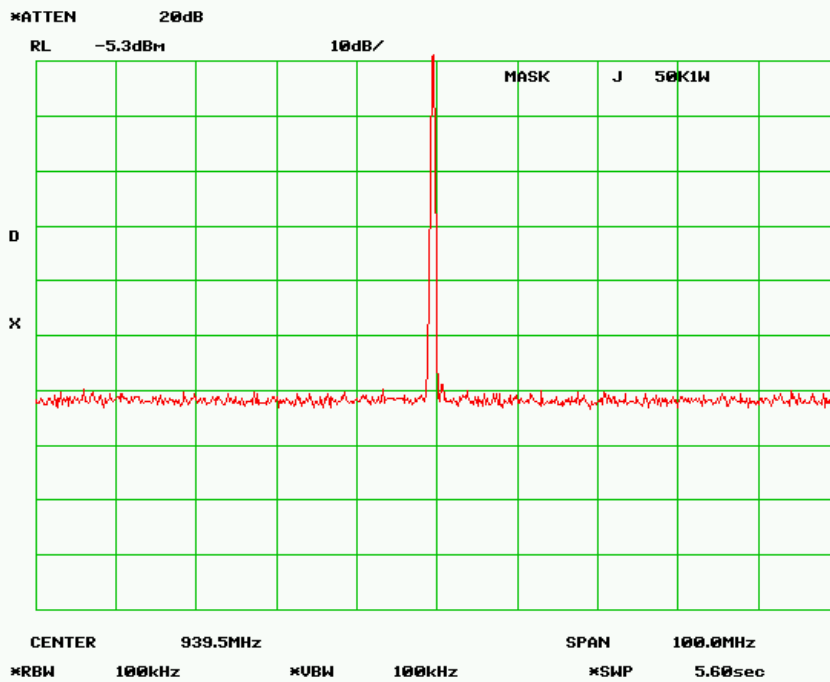
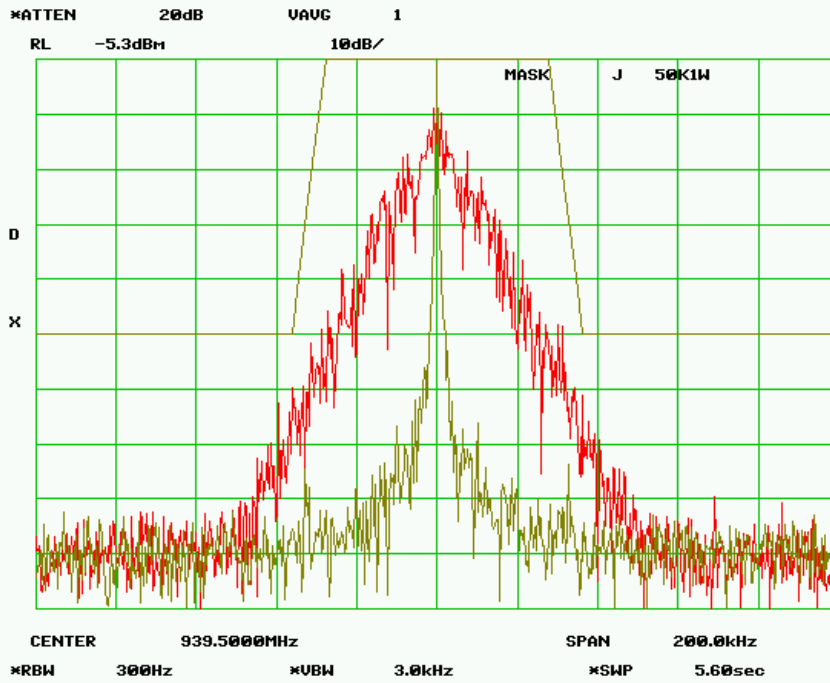

MASK J - 50 kHz - 10.0 Watts
RF Frequency 939.500 MHz
SPECTRUM FOR EMISSION - 30K5F1D
Data Rate = 128 kbps
PEAK DEVIATION = 11.66 kHz

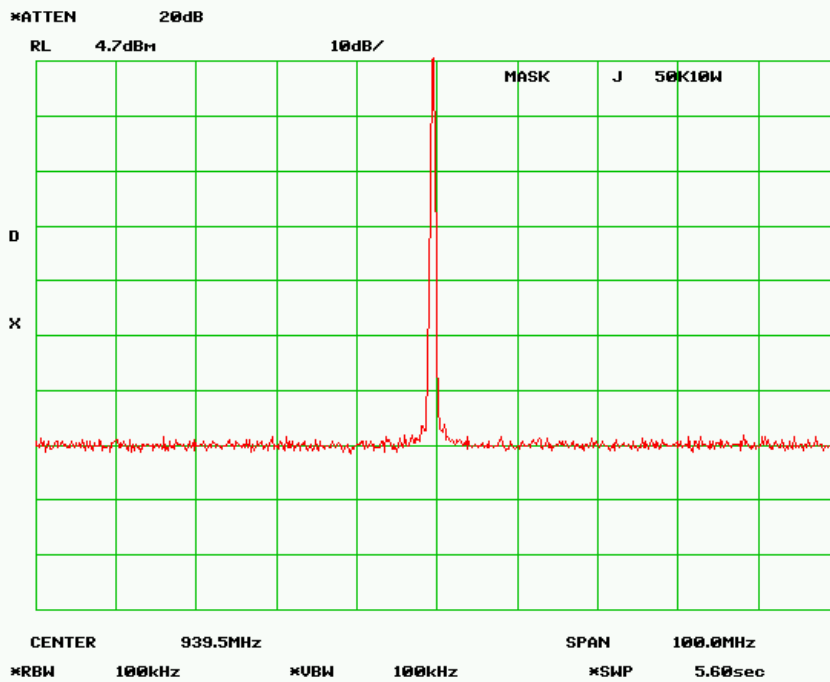
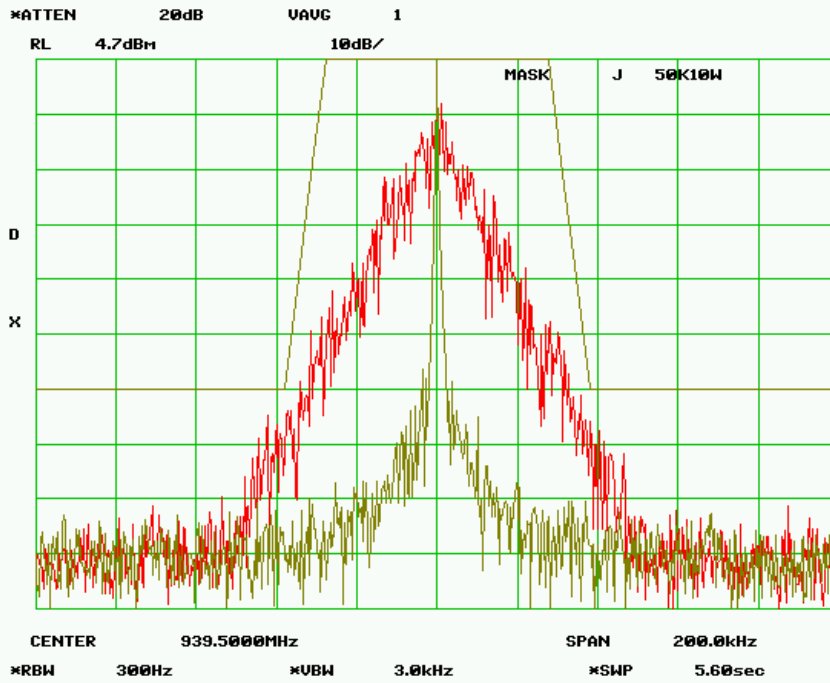

12.0 Mask J – Part 90.210(j) Aggregation for 100 kHz Channel

NAME OF TEST: Transmitter Occupied Bandwidth for Emission Designators
51K0F1D, 52K7F1D, 49K7F1D, 51K3F1D

RULE PART NUMBER: FCC: 2.202, 90.209 (b)(5), 90.210(j), 90.945(h) 2.1049 (c) (1)

MINIMUM STANDARDS: **Mask J**
 Sidebands and Spurious [Rule 90.210 (j), P = 10 Watts and P=1 Watt]
 Authorized Bandwidth = 13.6 kHz [Rule 90.209(b) (5)]
 Fo of more than 2.5 kHz, but no more than 6.25 kHz: At least 53 log (f_d/2.5) dB
 Fo of more than 6.25 kHz, but no more than 9.5 kHz: At least 103 log (f_d/3.9) dB;
 Fo of more than 9.5 kHz: At least 157 log (f_d/5.3) dB, or 50 + 10 log (P) dB or 70 dB,
 whichever is the lesser attenuation.

Part 90.645(h) allows for aggregating contiguous channels.

51K0F1D 9 contiguous channels
 52K7F1D 9 contiguous channels
 49K7F1D 9 contiguous channels
 51K3F1D 9 contiguous channels

For emission designators 51K0F1D, 52K7F1D, 49K7F1D, 51K3F1D. The limits are derived by adding 8*(6.25 kHz) = 50.0 kHz to each of the original limits.

Attenuation = 0 dB at Fo to 52.5 kHz
 Attenuation = 21.0 dB at 56.25 kHz
 Attenuation = 22.0 at 59.5 kHz
 Attenuation = 60 dB at frequencies greater than 62.8 kHz @ 10 W
 Attenuation = 50 dB at frequencies greater than 61.0 kHz @ 1 W

TEST RESULTS: Meets minimum standards (see data on following page)

TEST CONDITIONS: Standard Test Conditions, 25 C
 RF Power Level = 1 Watt and 10 Watts
 Voltage = 20VDC

TEST PROCEDURE: TIA/EIA – 603-C, 2.2.13, 3.2.11.2

TEST EQUIPMENT: 50-Ohm Attenuator, Bird Electronics Model 50-A-FFN-20 (20dB, 50W)
 50-Ohm Attenuator, Bird Electronics Model 10-A-MFN-10 (10dB, 10W)
 50-Ohm Attenuator, Pasternack Model PE7002-10 (10dB)
 DC Power Supply, Hewlett Packard Model 6653A
 Spectrum Analyzer, Hewlett Packard Model HP8563E
 Modulation Analyzer, Hewlett Packard Model HP8901A

TEST SET-UP:

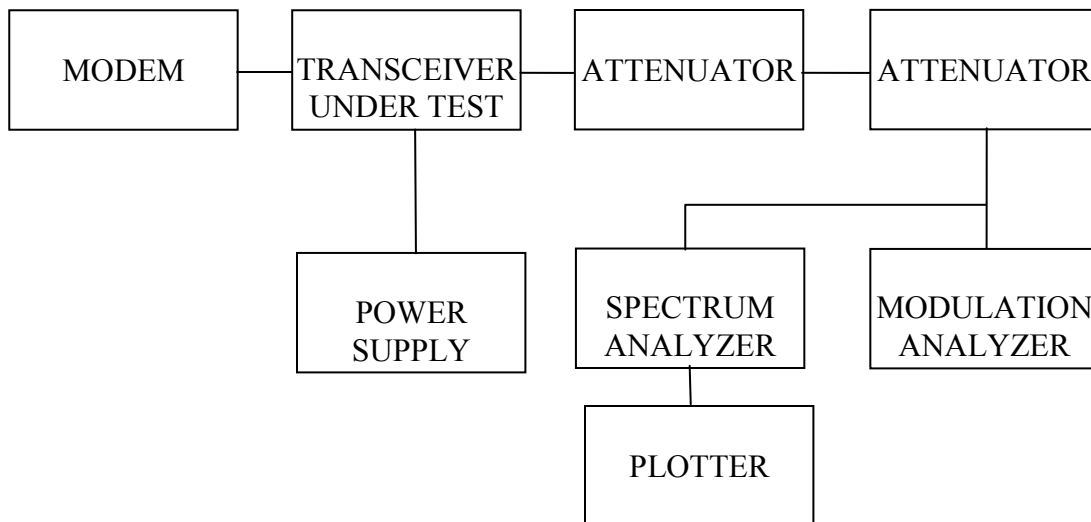

MASK J - 100 kHz - 1.0 Watts
RF Frequency 939.500 MHz
SPECTRUM FOR EMISSION - 51K0F1D
Data Rate = 64 kbps
PEAK DEVIATION = 10.81 kHz

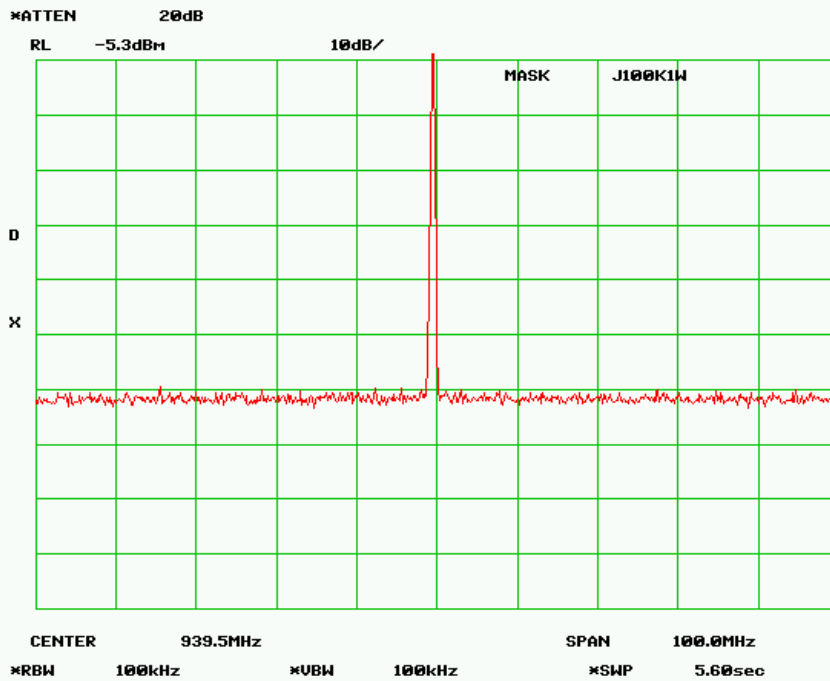
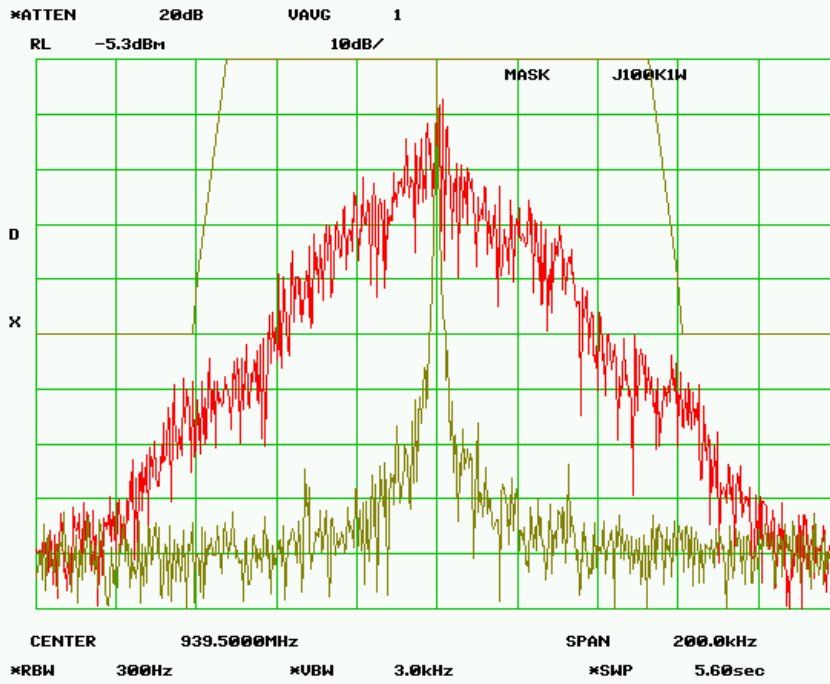

MASK J - 100 kHz - 10.0 Watts
RF Frequency 939.500 MHz
SPECTRUM FOR EMISSION - 51K0F1D
Data Rate = 64 kbps
PEAK DEVIATION = 10.81 kHz

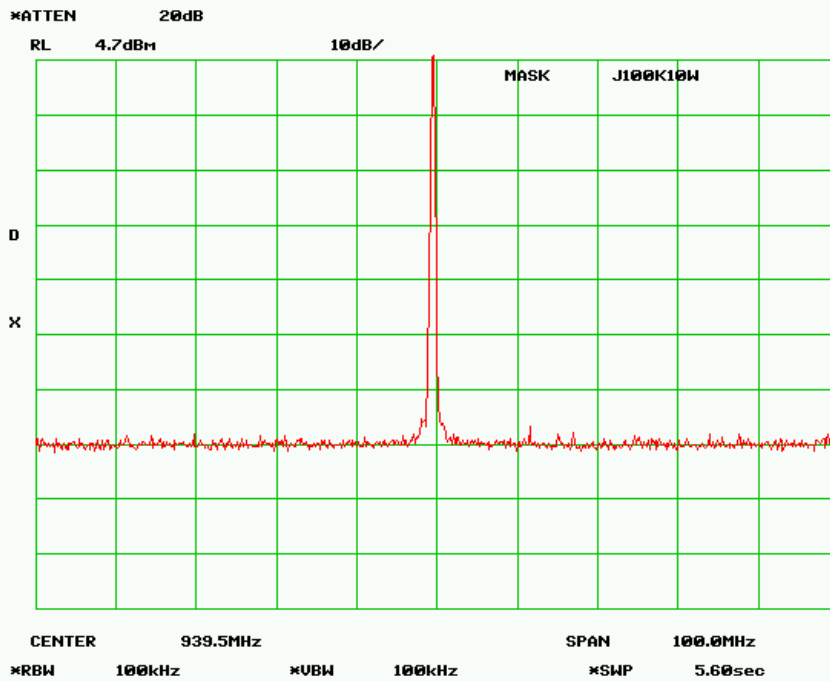
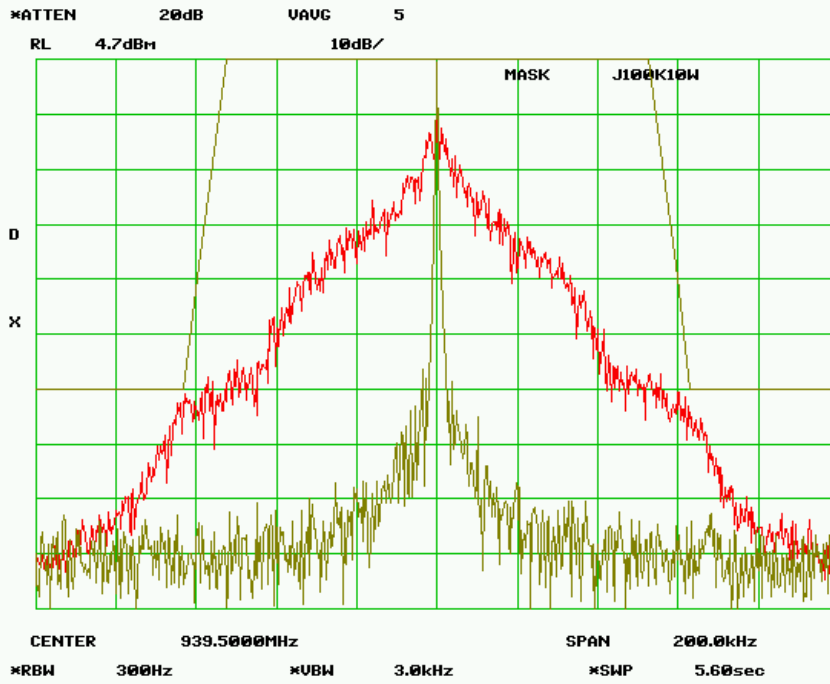

MASK J - 100 kHz - 1.0 Watts
RF Frequency 939.500 MHz
SPECTRUM FOR EMISSION - 52K7F1D
Data Rate = 128 kbps
PEAK DEVIATION = 12.40kHz

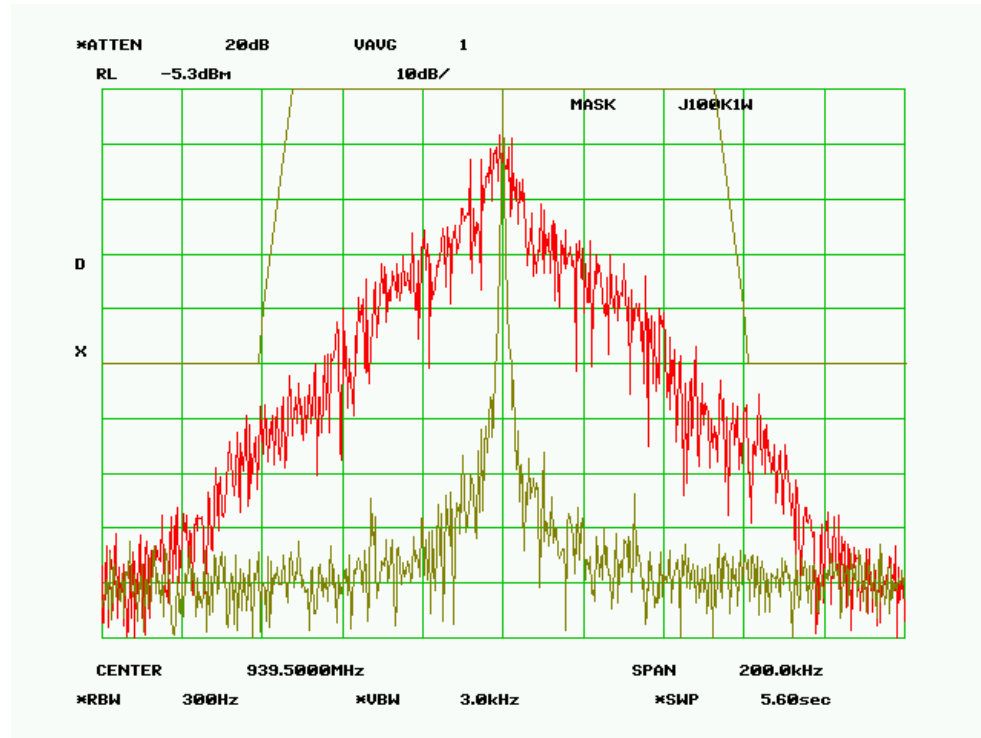

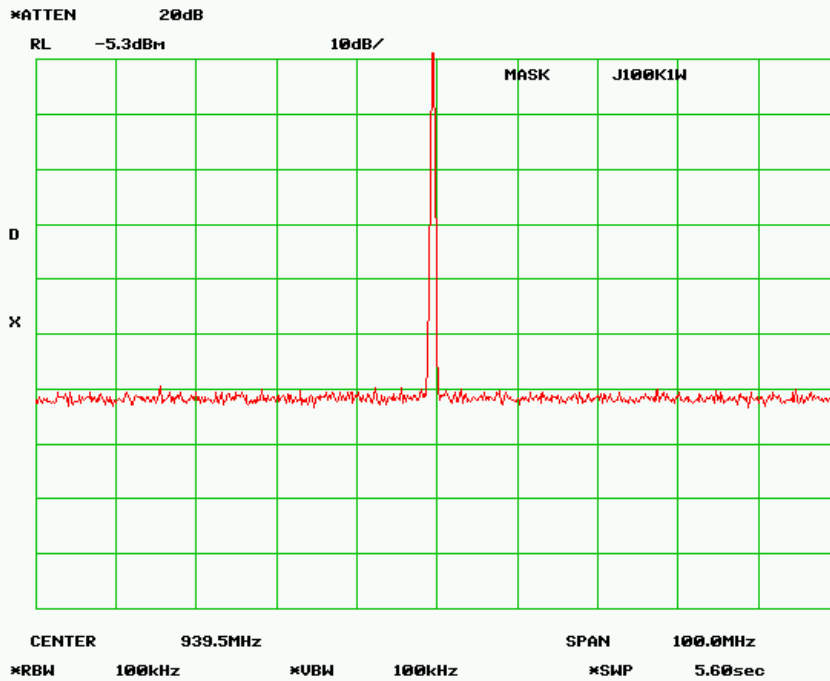

MASK J - 100 kHz - 10.0 Watts
RF Frequency 939.500 MHz
SPECTRUM FOR EMISSION - 52K7F1D
 Data Rate = 128 kbps
 PEAK DEVIATION = 12.40kHz

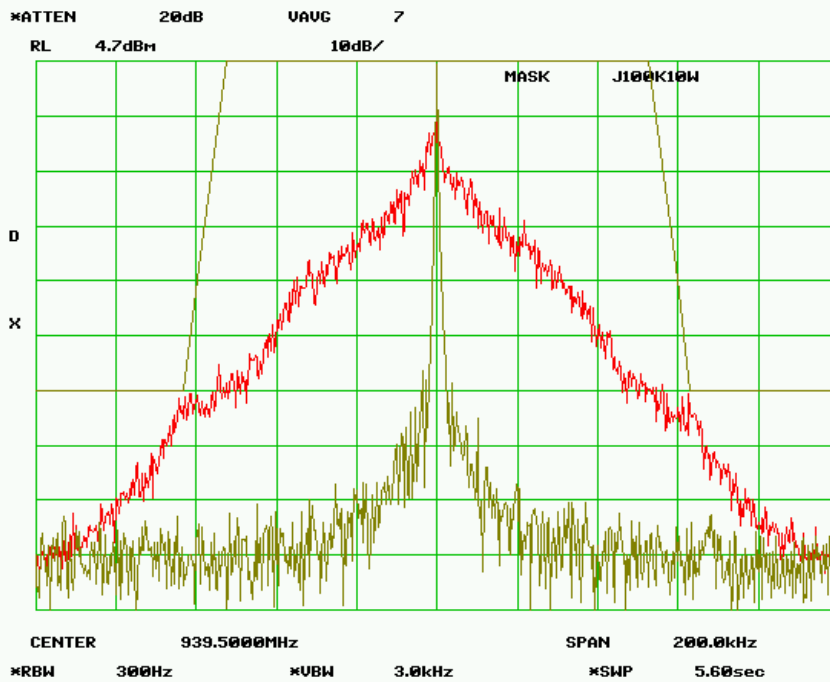

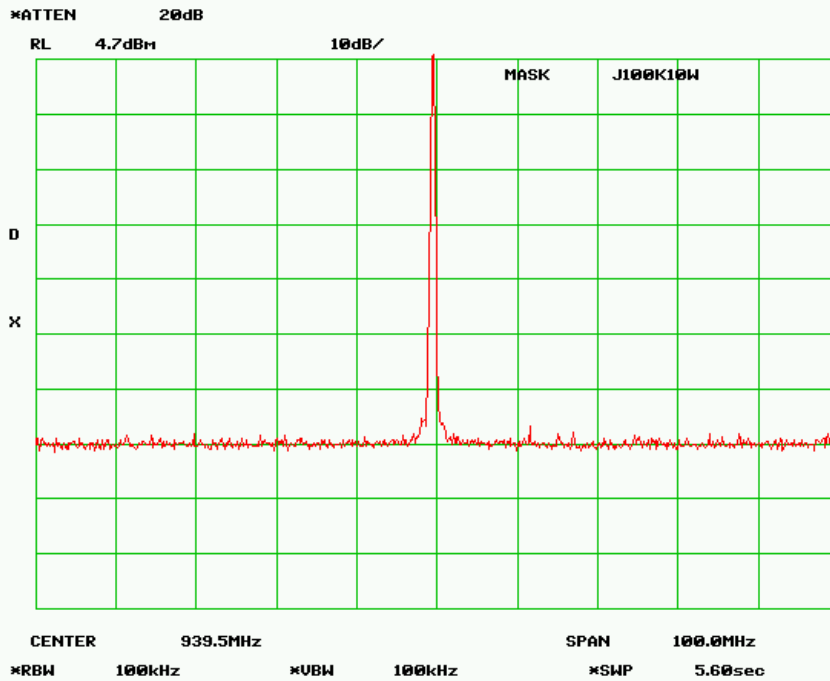

MASK J - 100 kHz - 1.0 Watts
RF Frequency 939.500 MHz
SPECTRUM FOR EMISSION - 49K7F1D
Data Rate = 192 kbps
PEAK DEVIATION = 13.02 kHz

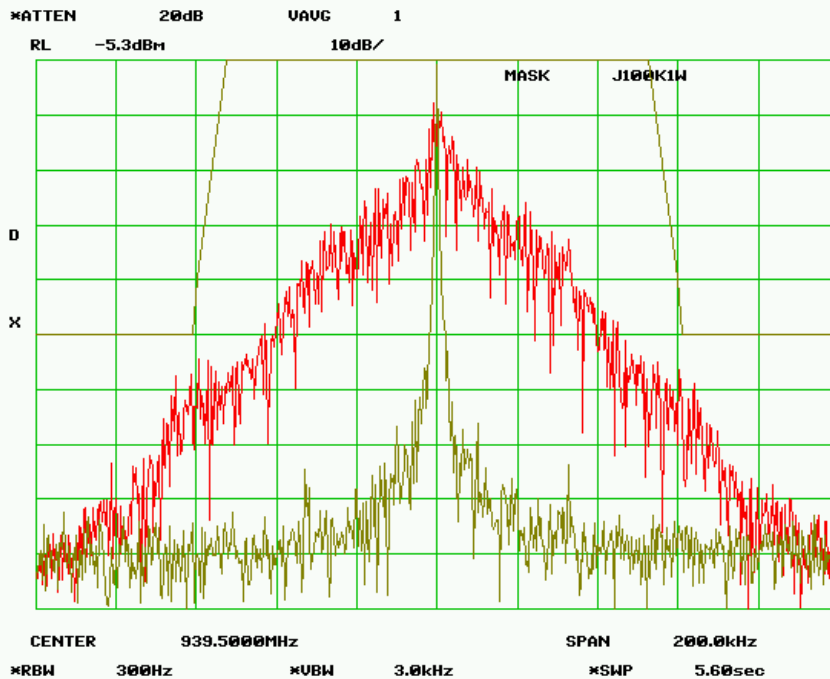

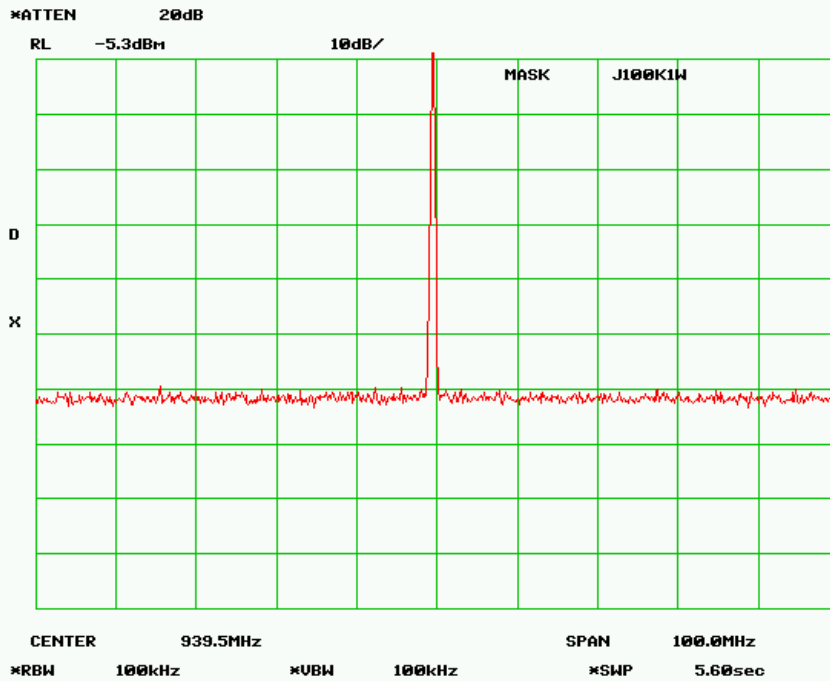

MASK J - 100 kHz - 10.0 Watts
RF Frequency 939.500 MHz
SPECTRUM FOR EMISSION - 49K7F1D
 Data Rate = 192 kbps
 PEAK DEVIATION = 13.02 kHz

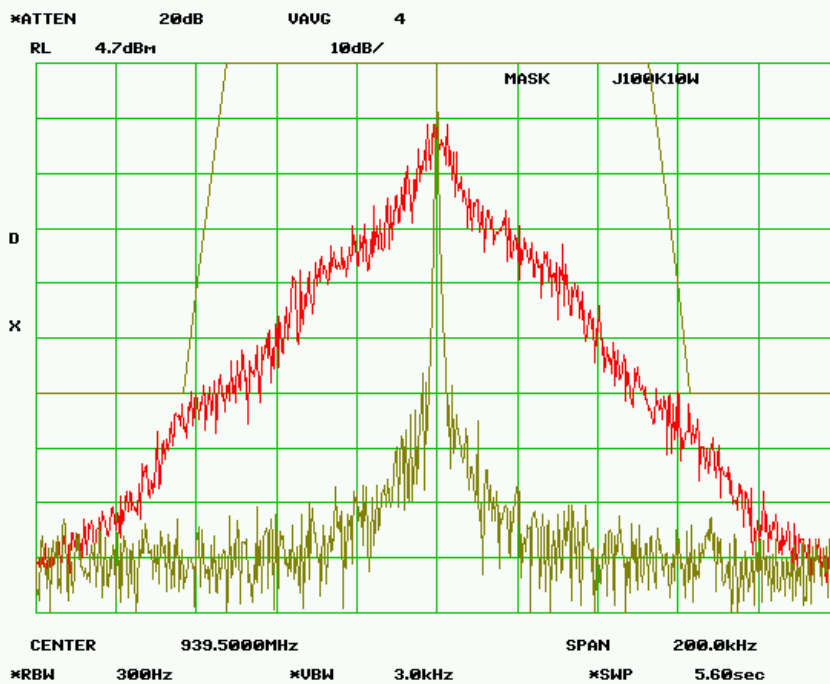

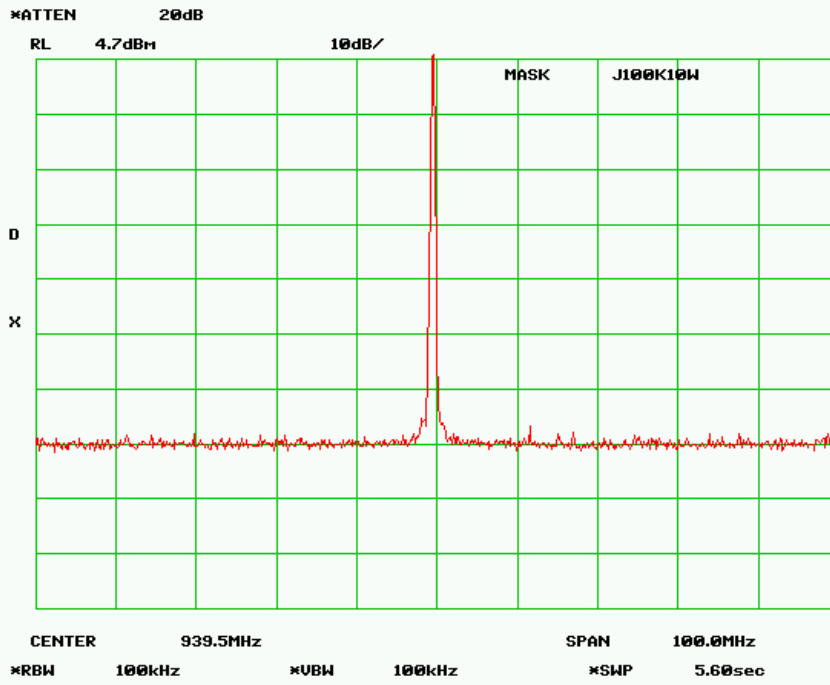

MASK J - 100 kHz - 1.0 Watts
RF Frequency 939.500 MHz
SPECTRUM FOR EMISSION - 51K3F1D
Data Rate = 256kbps
PEAK DEVIATION = 13.77 kHz

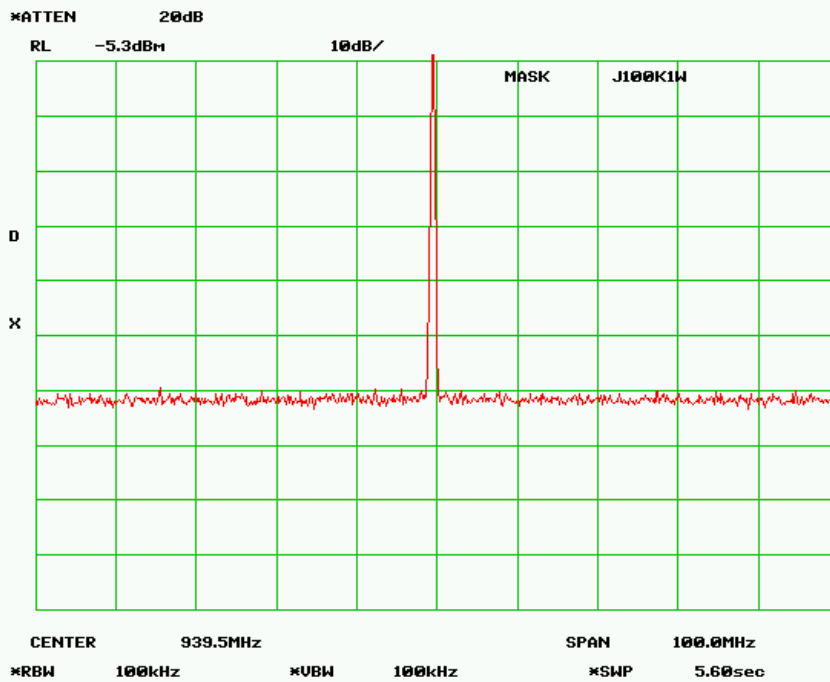
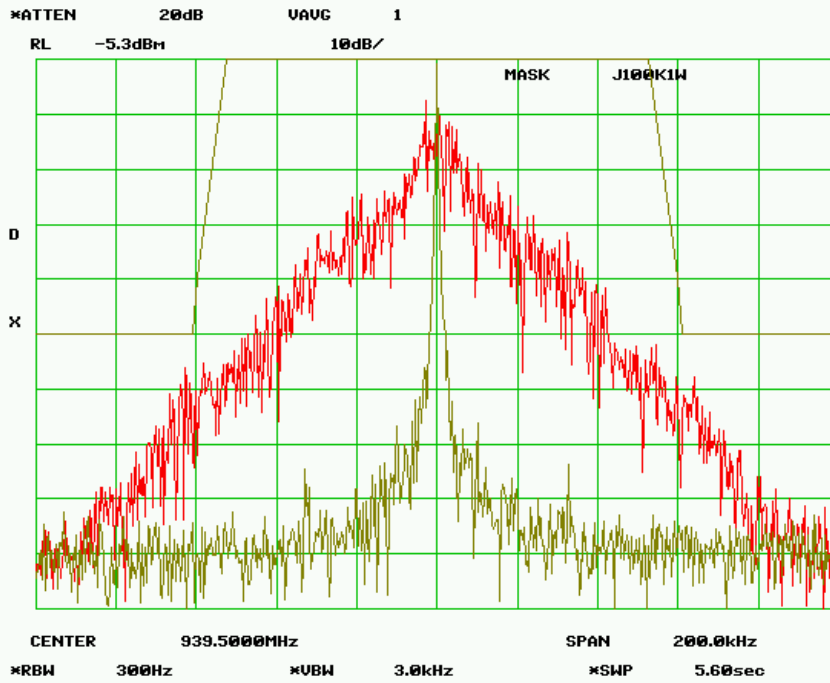

MASK J - 100 kHz - 10.0 Watts
RF Frequency 939.500 MHz
SPECTRUM FOR EMISSION - 51K3F1D
Data Rate = 256kbps
PEAK DEVIATION = 13.77 kHz

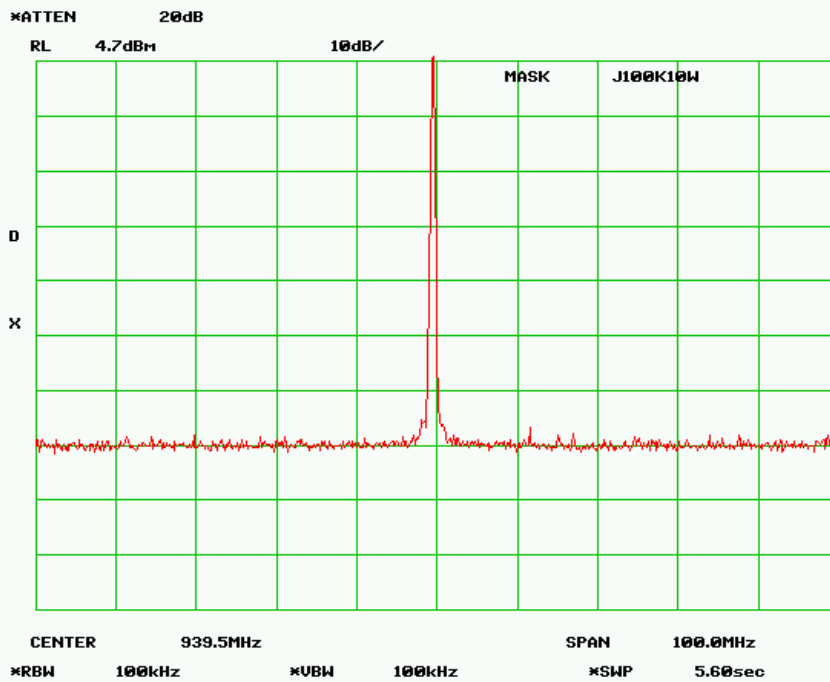
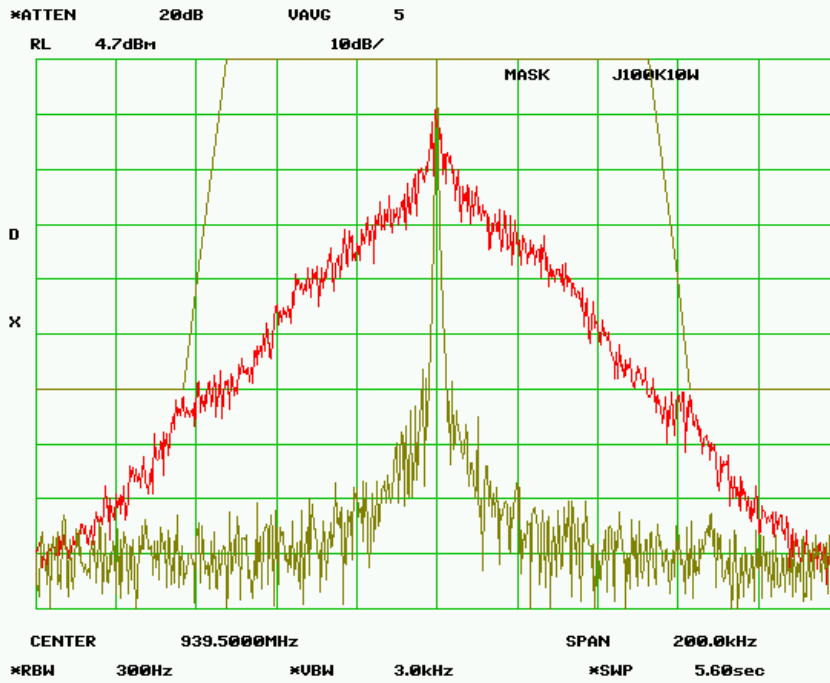

13.0 Mask G - Part 90.210(g)– 20 kHz ABW & Mask 90.691 25 kHz Channel

NAME OF TEST:	Transmitter Occupied Bandwidth for Emission Designators 16K5F1D, 16K8F1D, 17K8F1D, and 17K0F1D
RULE PART NUMBER:	FCC: 2.202, 90.209 (b)(5), 90.210(g), 2.1049 (c) (1)
MINIMUM STANDARDS:	<p>Mask G Sidebands and Spurious [P = 10 Watts and P=1 Watt] Authorized Bandwidth = 20 kHz From Fo to 10 kHz, down 0 dB. Greater than 10 kHz to 250% of authorized BW, at least $116 * \log_{10}(f_d / 6.1)$ or $50 + 10 \log (P)$ or 70 dB, whichever is the lesser attenuation Greater than 250% of authorized BW, $43 + 10\log_{10}(P)$</p> <p>Attenuation = 0 dB at Fo to 10 kHz Attenuation = 25 dB at 10 kHz Attenuation = 36.1 dB at 12.5 kHz Attenuation = 60 dB at 20.1 kHz @ 10W Attenuation = 50 dB at 16.5 kHz @ 1W Attenuation = 53 dB at >50.0 kHz @ 10W Attenuation = 43 dB at >50.0 kHz @ 1W</p> <p>Mask 90.691 The Mask G plots of this section are more restrictive than the 90.691 mask requirements. The device is compliant with Part 90.691.</p> <p>Sidebands and Spurious [P = 10 Watts and P=1 Watt] From Fo to 12.5 kHz, down 0 dB. Greater than 12.5 kHz to 37.5kHz $116 * \log_{10}(f_d / 6.1)$ or $50 + 10 \log (P)$ or 70 dB, whichever is the lesser attenuation Greater than 37.5 kHz $43 + 10\log_{10}(P)$</p> <p>Attenuation = 0 dB at Fo to 12.5 kHz Attenuation = 36.1 dB at >12.5 kHz Attenuation = 60 dB at 20.1 kHz @ 10W Attenuation = 50 dB at 16.5 kHz @ 1 W Attenuation = 53 dB at >37.5 kHz @ 10W Attenuation = 43 dB at >37.5 kHz @ 1W</p>
TEST RESULTS:	Meets minimum standards (see data on following page)
TEST CONDITIONS:	Standard Test Conditions, 25 C RF Power Level = 1 Watt and 10 Watts Voltage = 20VDC
TEST PROCEDURE:	TIA/EIA – 603-C
TEST EQUIPMENT:	50-Ohm Attenuator, Bird Electronics 50-A-FFN-20 (20dB, 50W) 50-Ohm Attenuator, Bird Electronics 10-A-MFN-10 (10dB, 10W) 50-Ohm Attenuator, Pasternack PE7002-10 (10dB) Power Supply, Instek Model GPS-2303 Spectrum Analyzer, Hewlett Packard Model HP8563E Modulation Analyzer, Hewlett Packard Model HP8901A

TEST SET-UP:

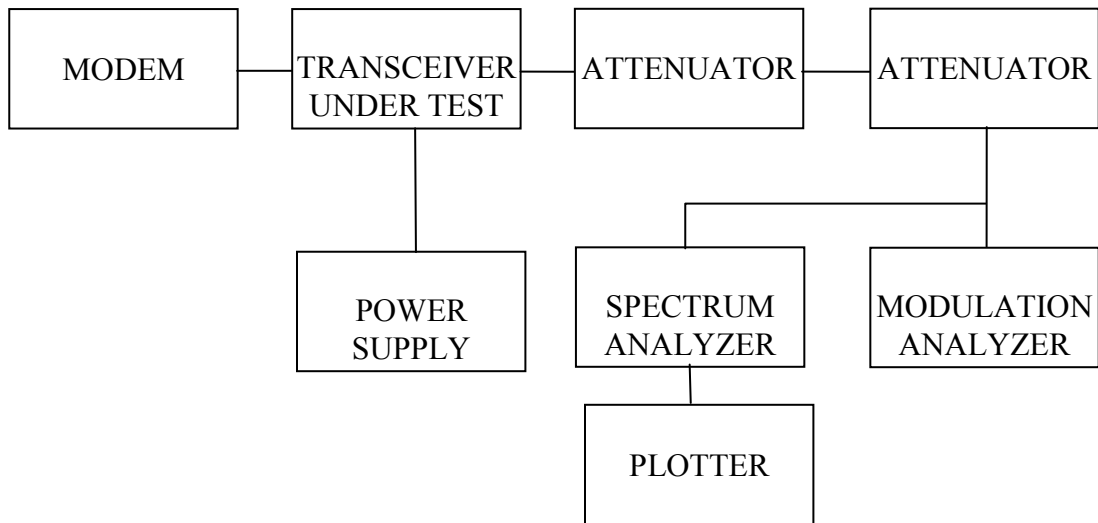

MASK G – 1.0 Watt
RF Frequency 929.050 MHz
SPECTRUM FOR EMISSION - 16K5F1D
 Data Rate = 16 kbps
 PEAK DEVIATION = 6.30 kHz

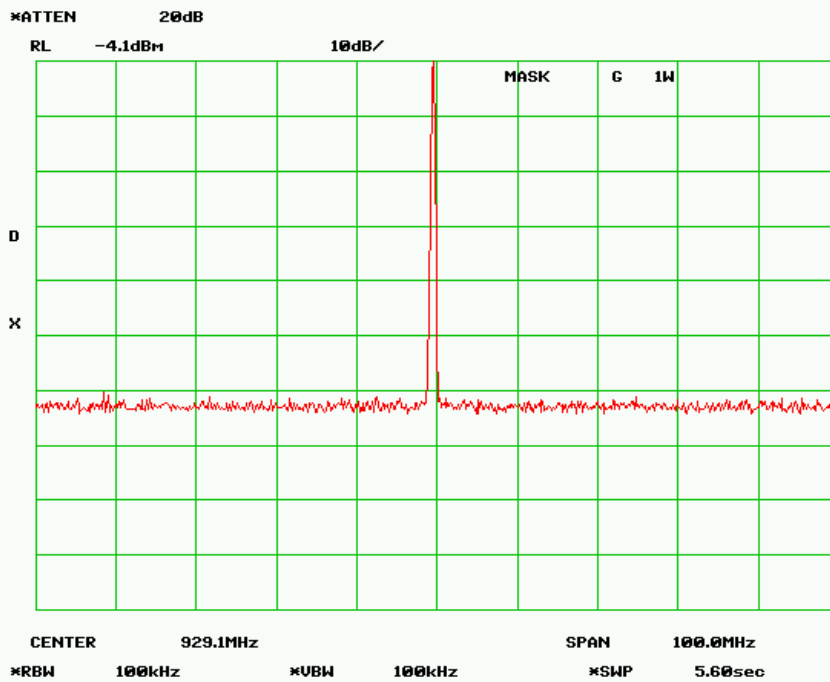
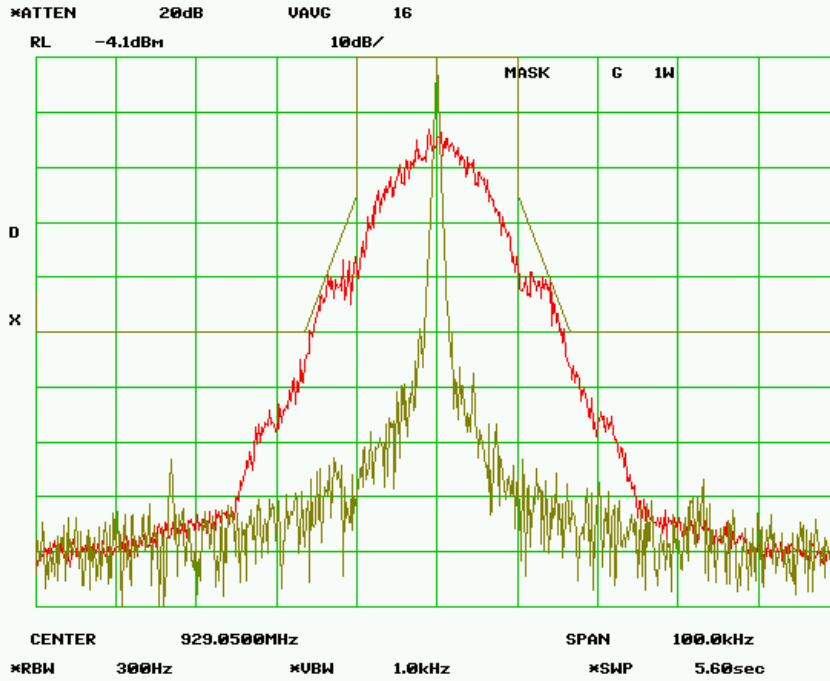

MASK G – 10 Watts
RF Frequency 929.050 MHz
SPECTRUM FOR EMISSION - 16K5F1D
Data Rate = 16 kbps
PEAK DEVIATION = 6.30 kHz

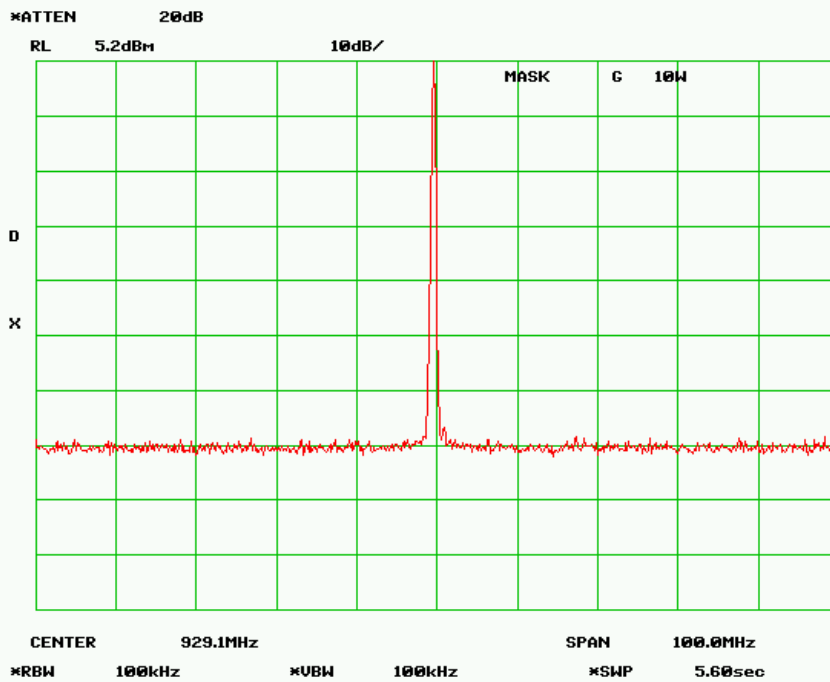
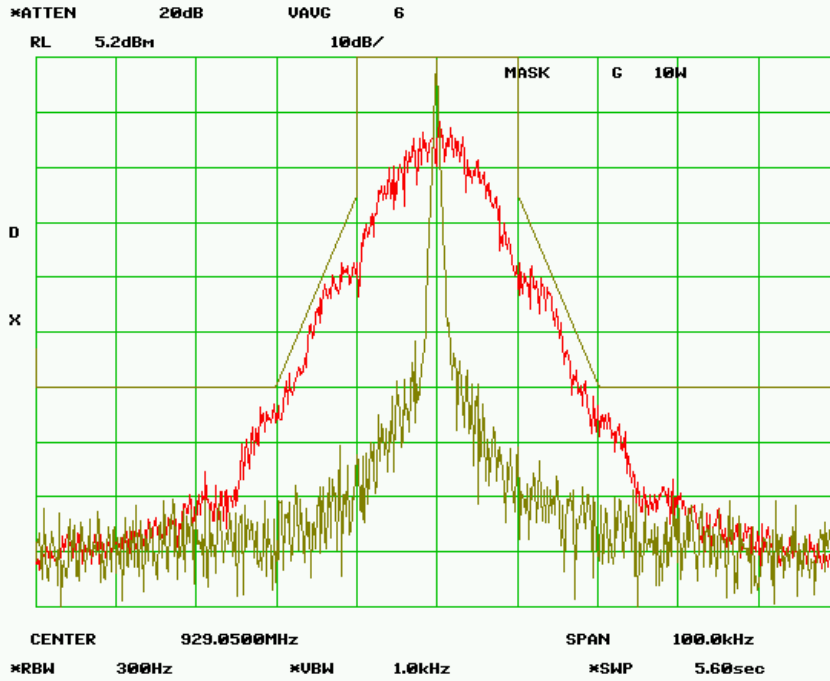

MASK G - 1.0 Watt
RF Frequency 929.050 MHz
SPECTRUM FOR EMISSION - 16K8F1D
Data Rate = 32 kbps
PEAK DEVIATION = 6.30 kHz

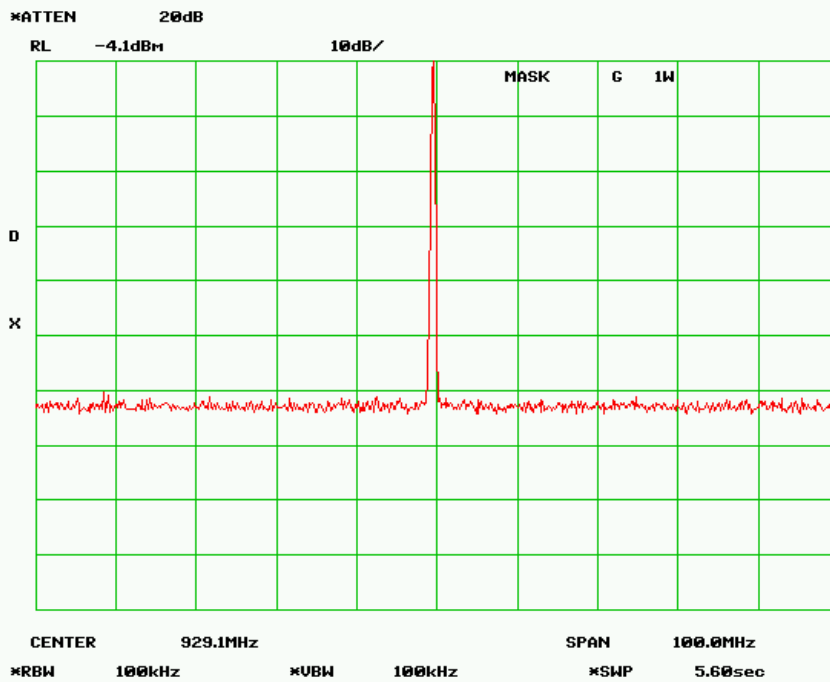
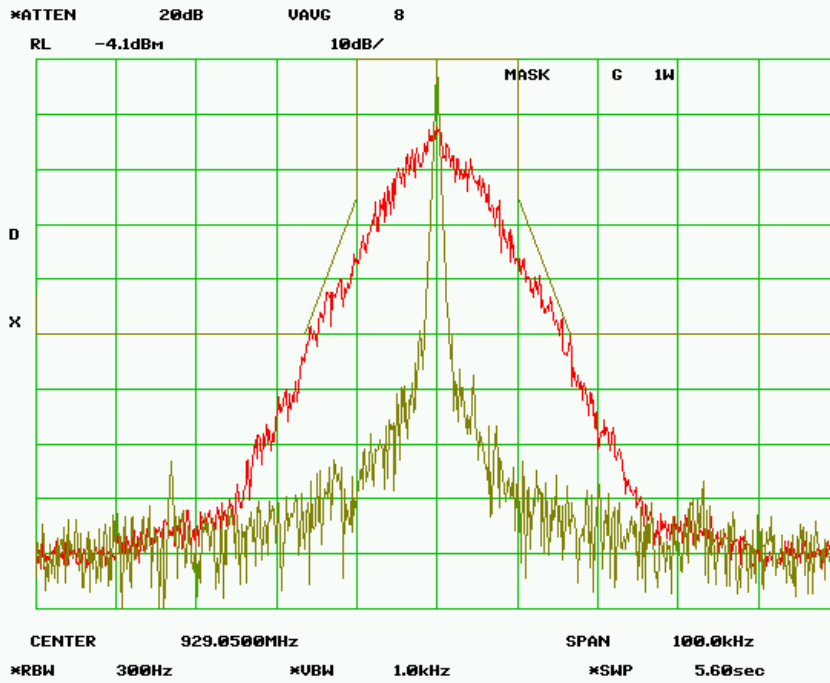

MASK G - 10 Watts
RF Frequency 929.050 MHz
SPECTRUM FOR EMISSION - 16K8F1D
 Data Rate = 32 kbps
 PEAK DEVIATION = 6.30 kHz

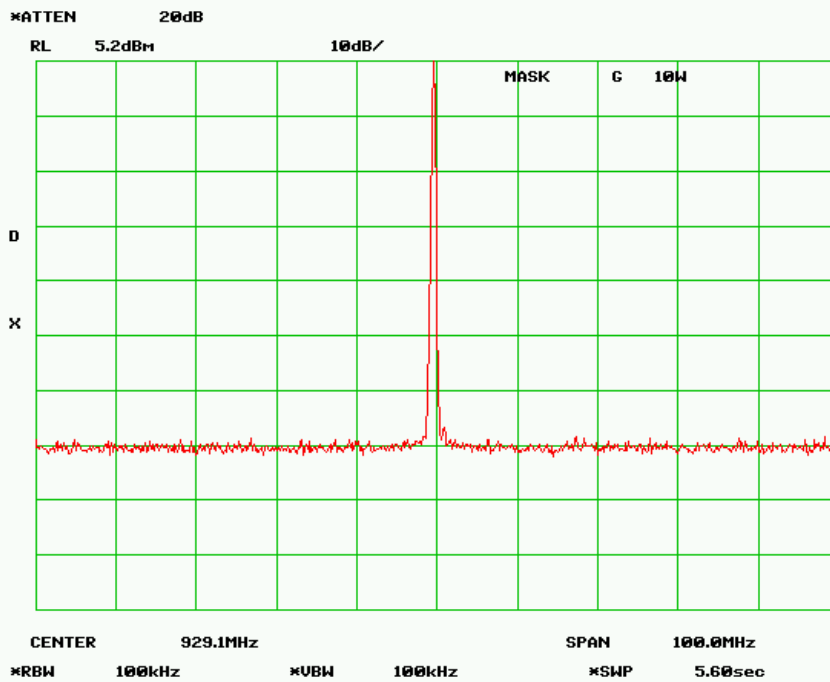
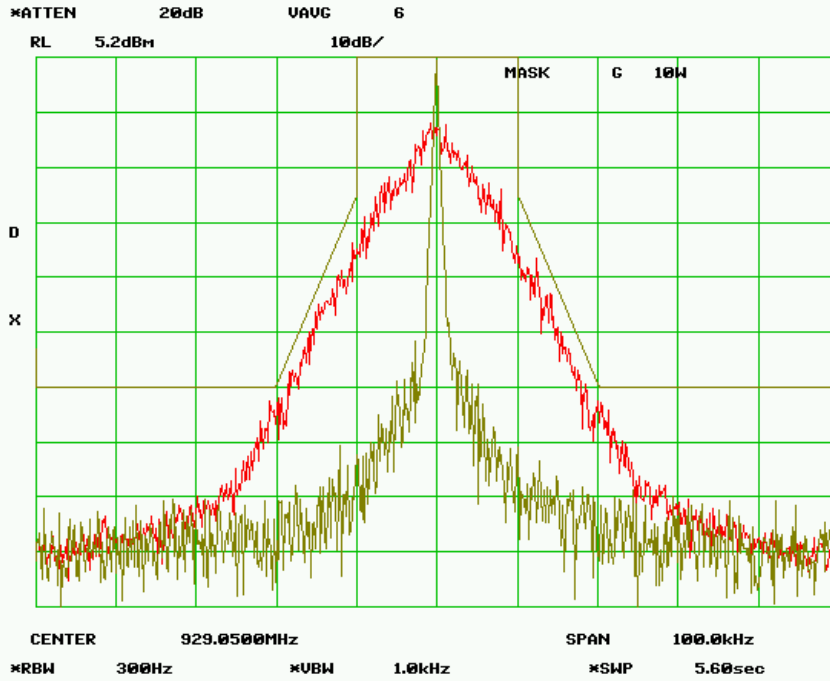

MASK G - 1.0 Watt
RF Frequency 929.050 MHz
SPECTRUM FOR EMISSION - 17K8F1D
 Data Rate = 48 kbps
 PEAK DEVIATION = 7.590 kHz

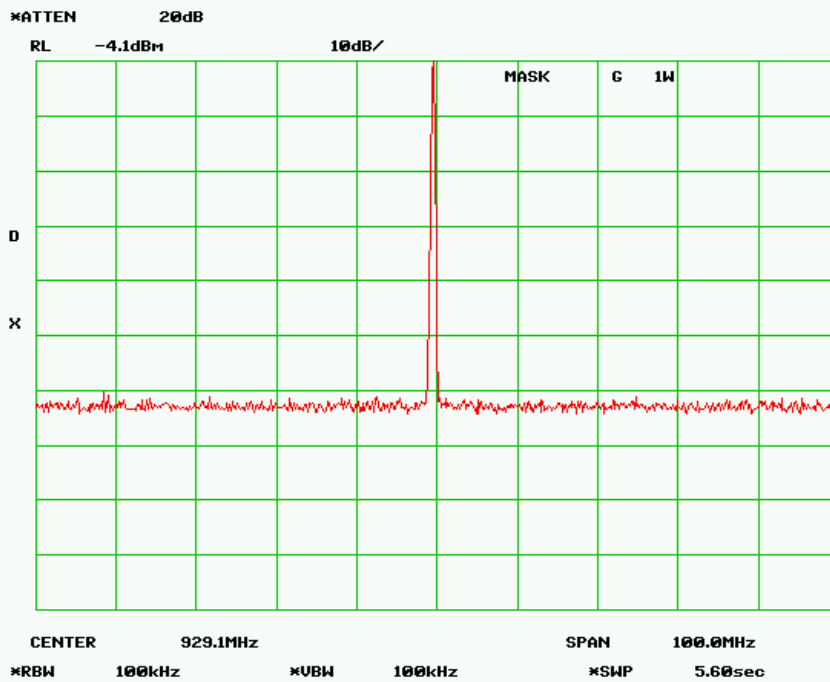
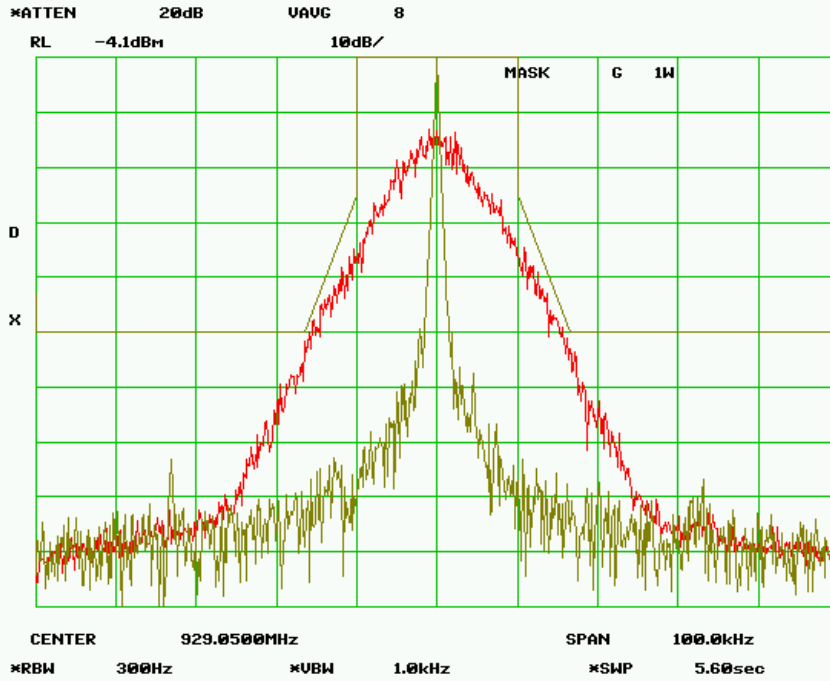

MASK G - 10 Watts
RF Frequency 929.050 MHz
SPECTRUM FOR EMISSION - 17K8F1D
Data Rate = 48 kbps
PEAK DEVIATION = 7.590 kHz

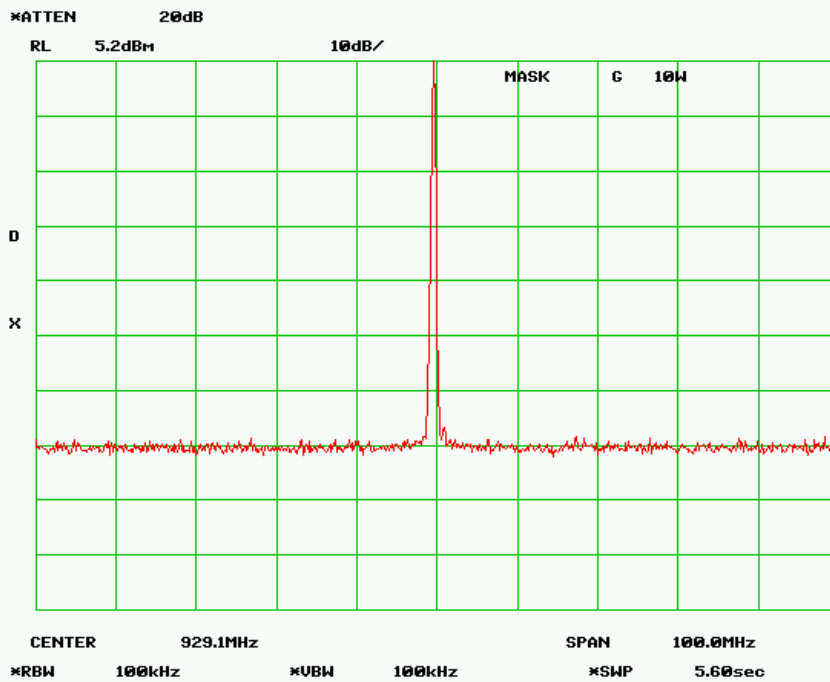
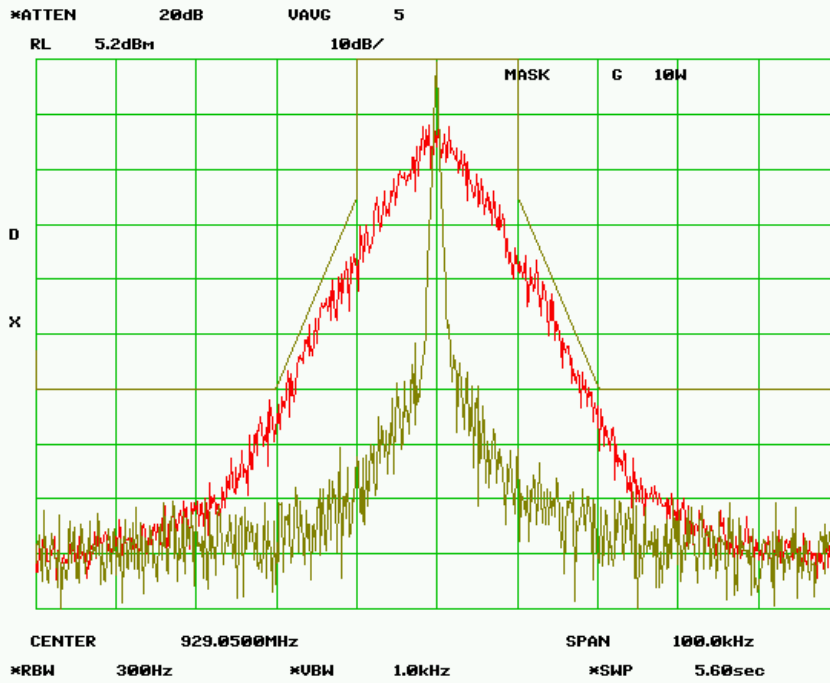

MASK G - 1.0 Watt
RF Frequency 929.050 MHz
SPECTRUM FOR EMISSION - 17K0F1D
 Data Rate = 64 kbps
 PEAK DEVIATION = 7.520 kHz

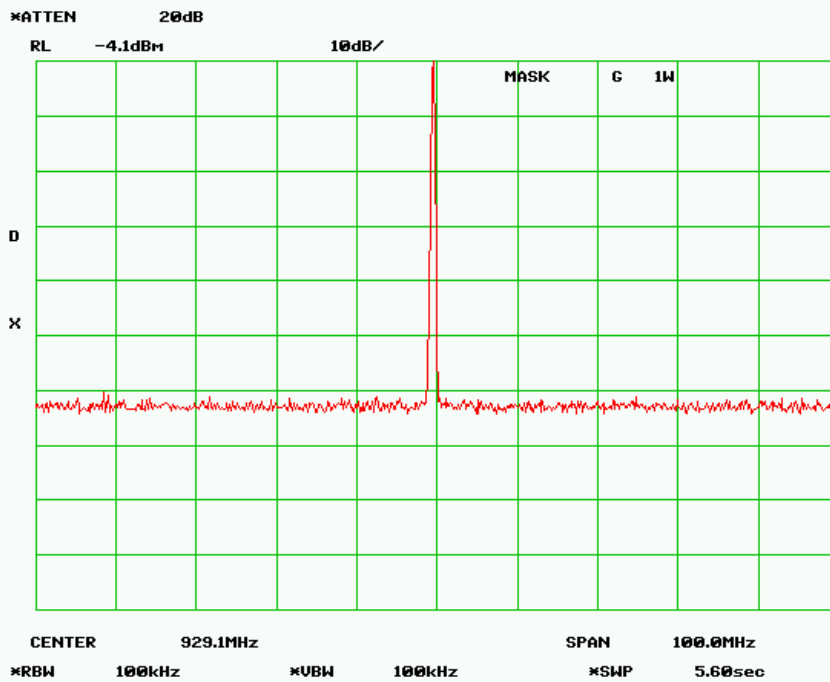
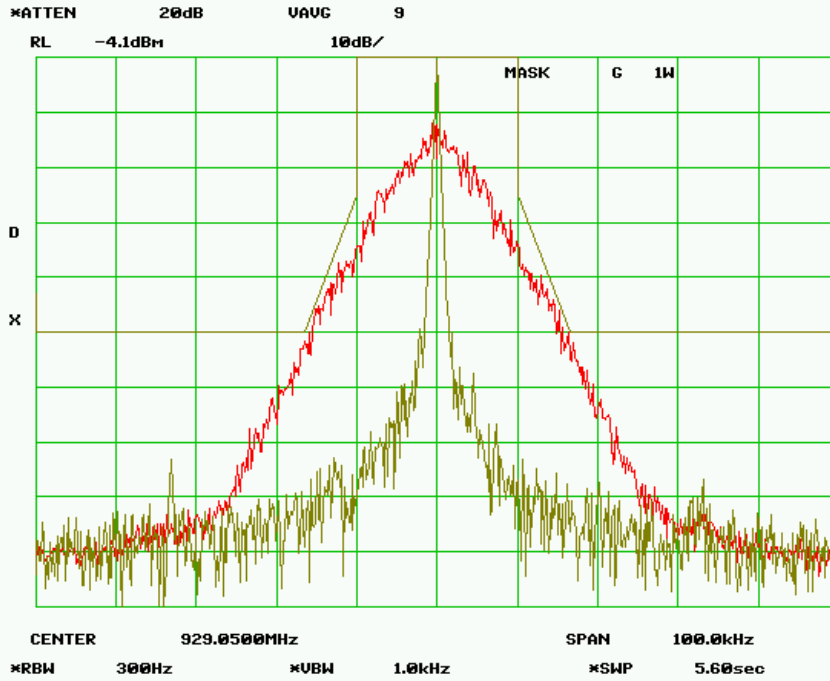

MASK G - 10 Watts
RF Frequency 929.050 MHz
SPECTRUM FOR EMISSION - 17K0F1D
 Data Rate = 64 kbps
 PEAK DEVIATION = 7.520 kHz

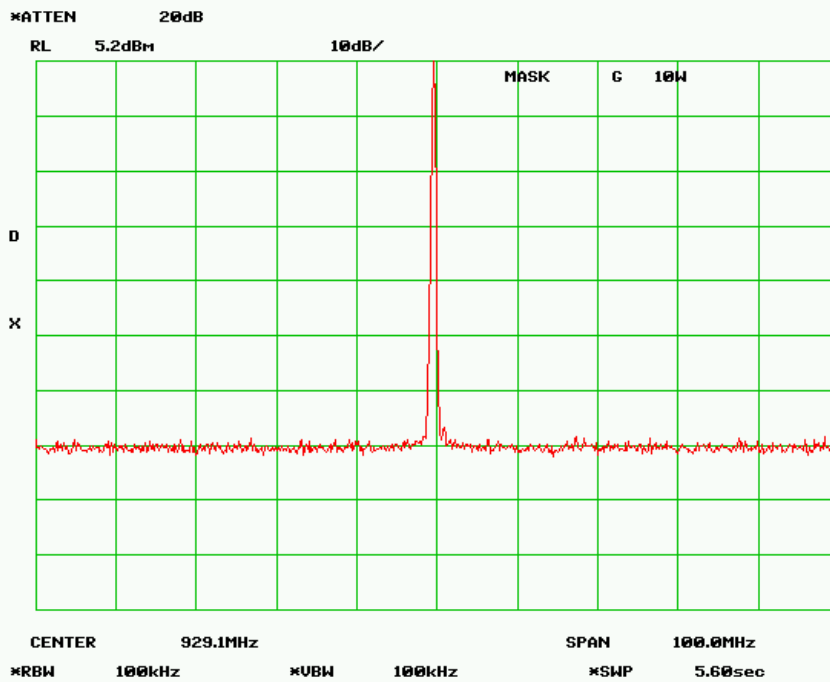
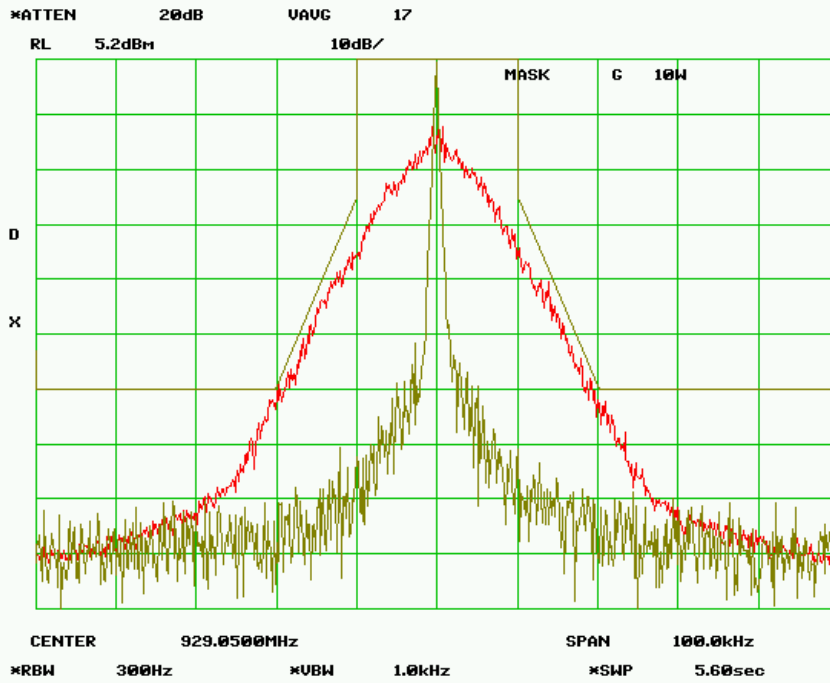

14.0 Part 24.133(a)(2) – 10 kHz ABW

NAME OF TEST: Transmitter Occupied Bandwidth for Emission Designators
8K20F1D, 8K30F1D, 8K50F1D and 8K08F1D

RULE PART NUMBER: FCC: 2.202, 2.1049 (c) (1), 24.133(a)(2)

MINIMUM STANDARDS: **Mask 24.133(a)(2) 12.5 kHz**
Sidebands and Spurious [P = 10 Watts and P=1 Watt]
Authorized Bandwidth = 10 kHz
From Fo to 5 kHz, down 0 dB.
From 5 kHz to 25 kHz, down $116 * \log_{10}(f_d + 5 / 3.05)$ dB, $50 + 10\log(P)$ or 70 dB.
Greater than 25 kHz, $43 + 10\log_{10}(P)$ or 80 dB.

Attenuation = 0 db at Fo to 5 kHz
Attenuation = 25 dB at 5 kHz
Attenuation = 60 dB at 10 kHz @ 10W
Attenuation = 50 dB at 8.22 kHz @ 1W
Attenuation = 53 dB at 25 kHz @ 10W
Attenuation = 43 dB at 25 kHz @ 1W

TEST RESULTS: Meets minimum standards (see data on following page)

TEST CONDITIONS: Standard Test Conditions, 25 C

TEST EQUIPMENT: 50-Ohm Attenuator, Bird Electronics 50-A-FFN-20 (20dB, 50W)
50-Ohm Attenuator, Bird Electronics 10-A-MFN-10 (10dB, 10W)
50-Ohm Attenuator, Pasternack PE7002-10 (10dB)
Power Supply, Instek Model GPS-2303
Spectrum Analyzer, Hewlett Packard Model HP8563E
Modulation Analyzer, Hewlett Packard Model HP8901A

TEST SET-UP:

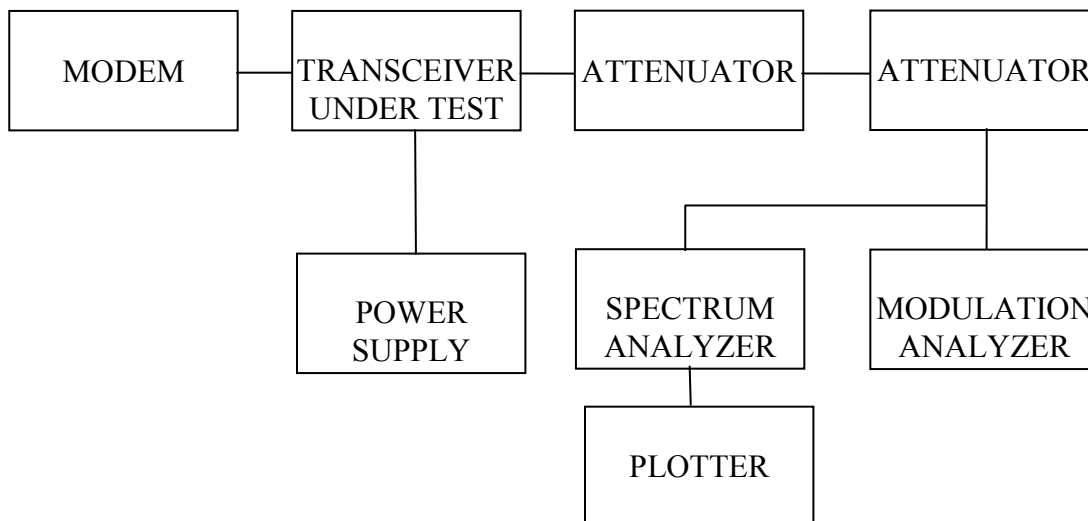

MASK 24.133a2 – 1.0 Watts
RF Frequency 940.950 MHz
SPECTRUM FOR EMISSION - 8K20F1D
 Data Rate = 8 kbps
 PEAK DEVIATION = 3.05 kHz

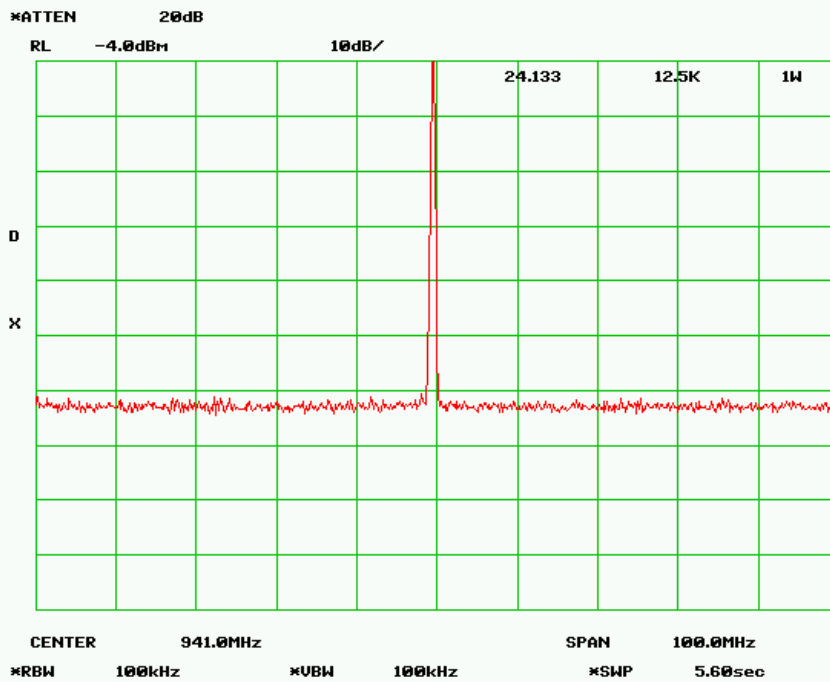
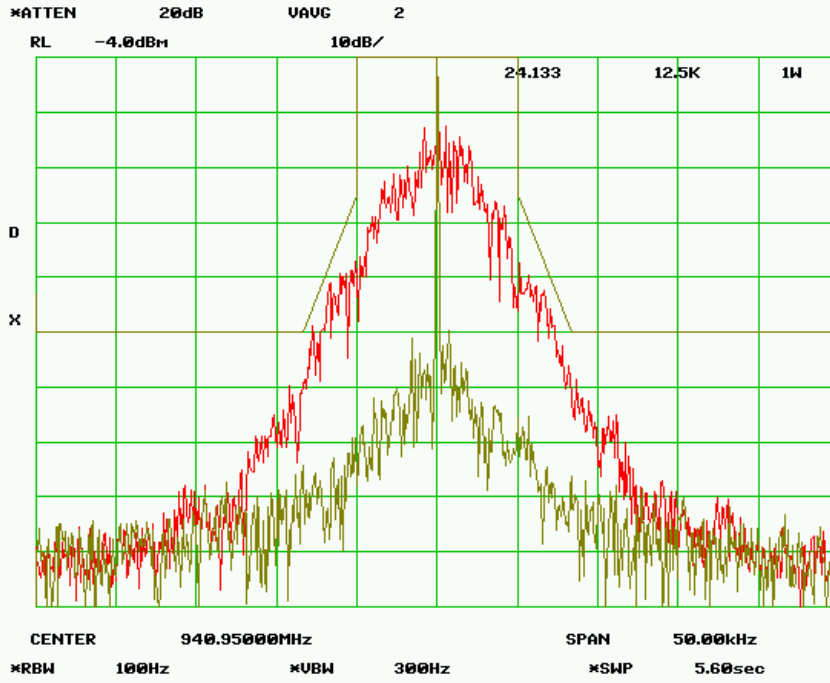

MASK 24.133a2 – 10.0 Watts
RF Frequency 940.950 MHz
SPECTRUM FOR EMISSION - 8K20F1D
 Data Rate = 8 kbps
 PEAK DEVIATION = 3.05 kHz

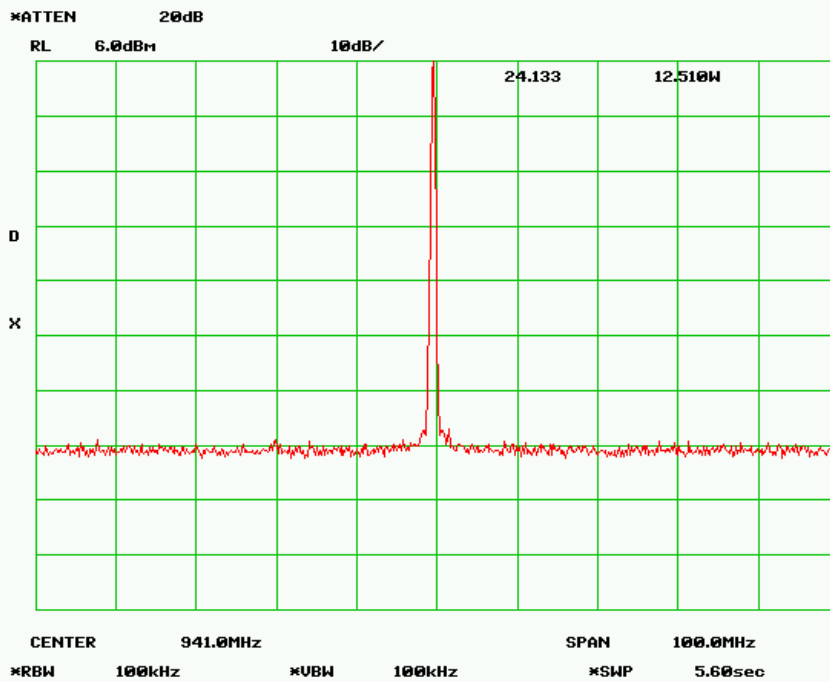
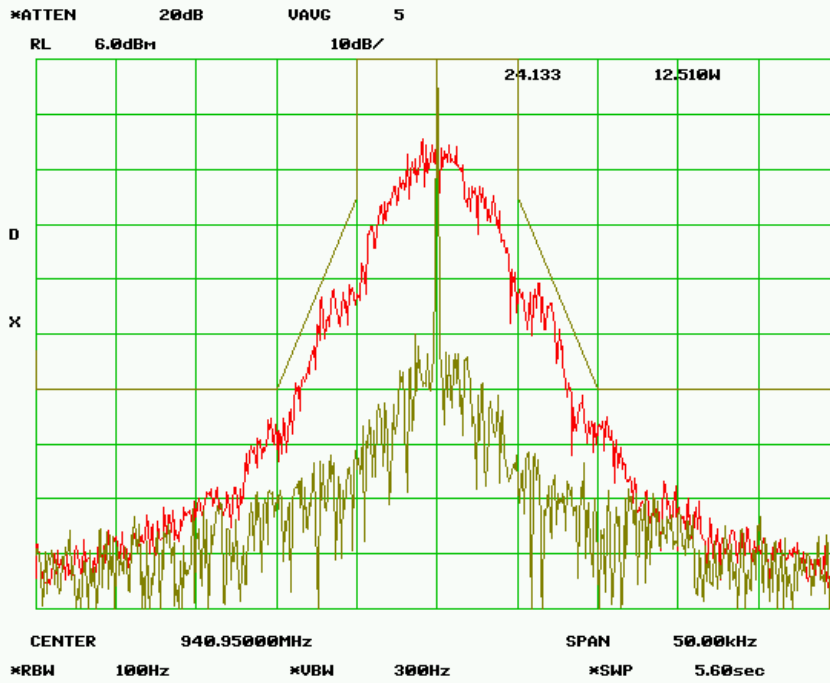

MASK 24.133a2 – 1.0 Watts
RF Frequency 940.950 MHz
SPECTRUM FOR EMISSION - 8K30F1D
 Data Rate = 16 kbps
 PEAK DEVIATION = 3.70 kHz

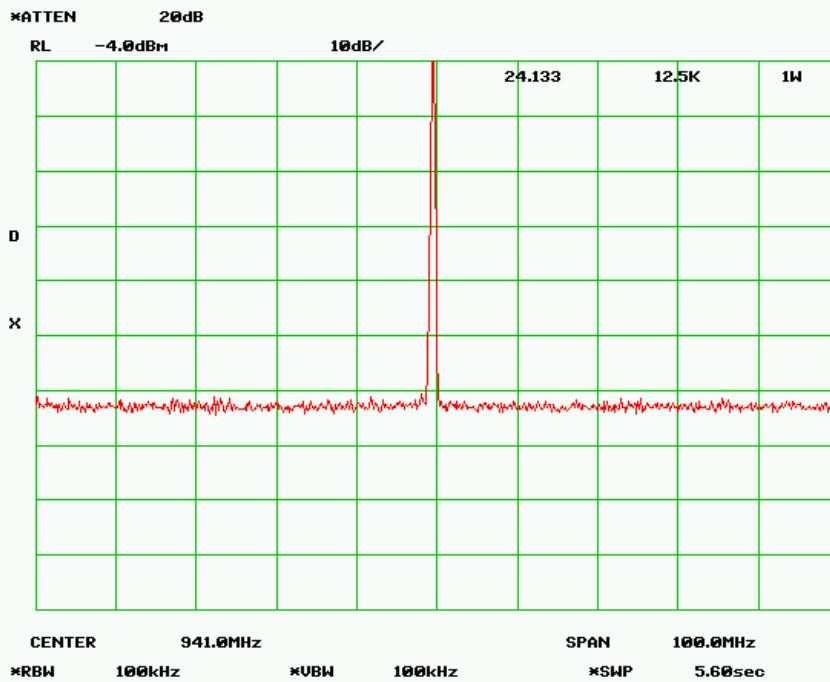
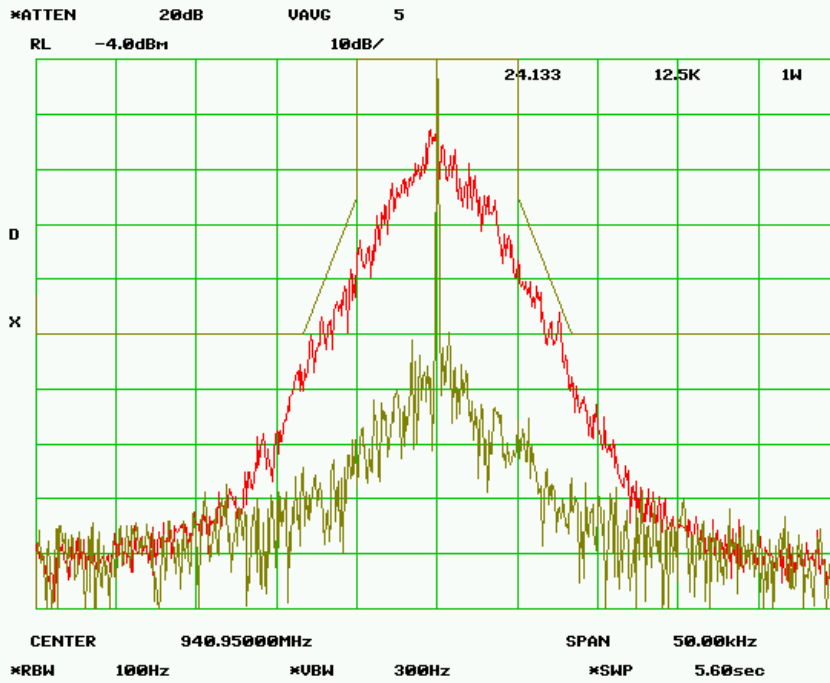

MASK 24.133a2 – 10.0 Watts
RF Frequency 940.950 MHz
SPECTRUM FOR EMISSION - 8K30F1D
 Data Rate = 16 kbps
 PEAK DEVIATION = 3.70 kHz

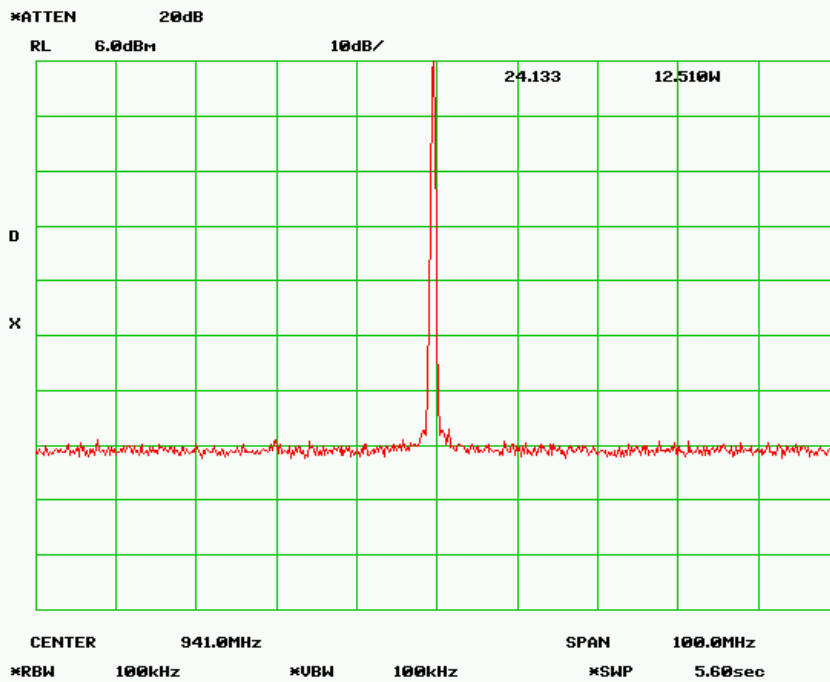
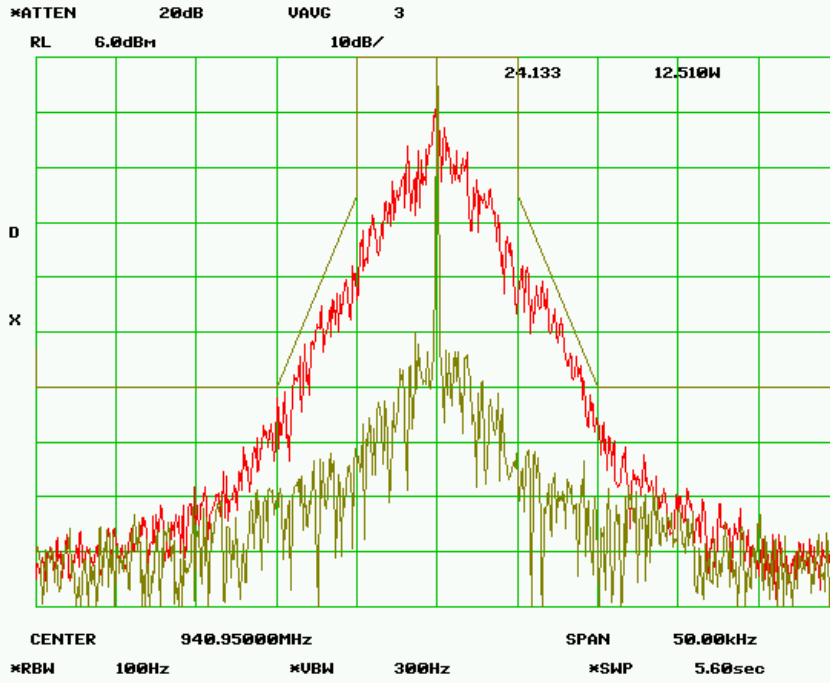

MASK 24.133a2 – 1.0 Watts
RF Frequency 940.950 MHz
SPECTRUM FOR EMISSION - 8K50F1D
 Data Rate = 24 kbps
 PEAK DEVIATION = 3.725 kHz

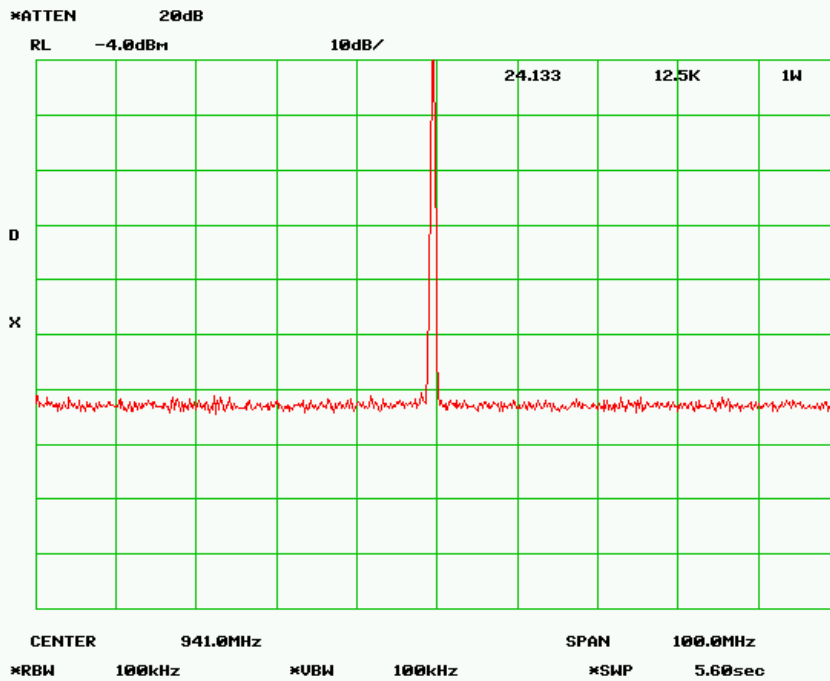
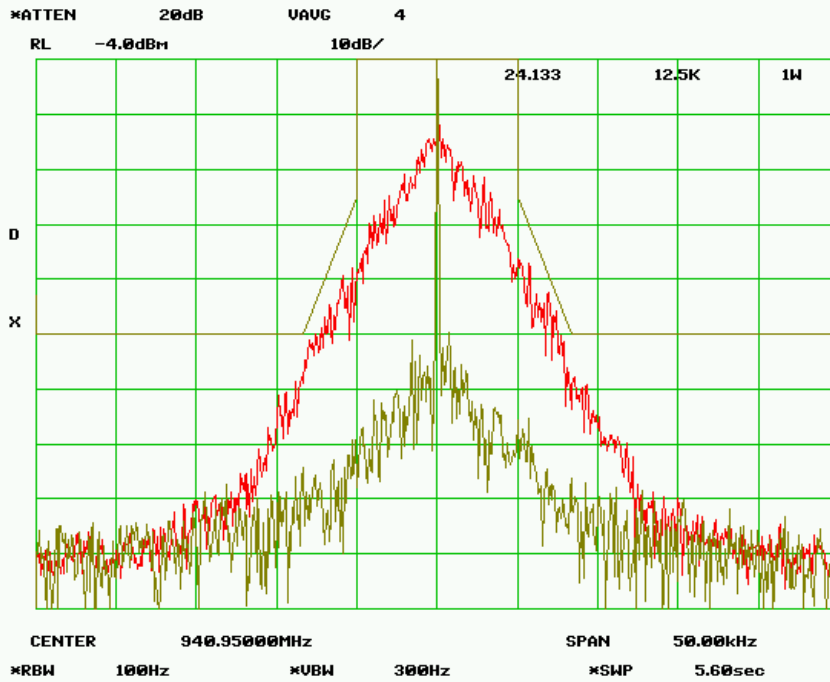

MASK 24.133a2 – 10.0 Watts
RF Frequency 940.950 MHz
SPECTRUM FOR EMISSION - 8K50F1D
Data Rate = 24 kbps
PEAK DEVIATION = 3.725 kHz

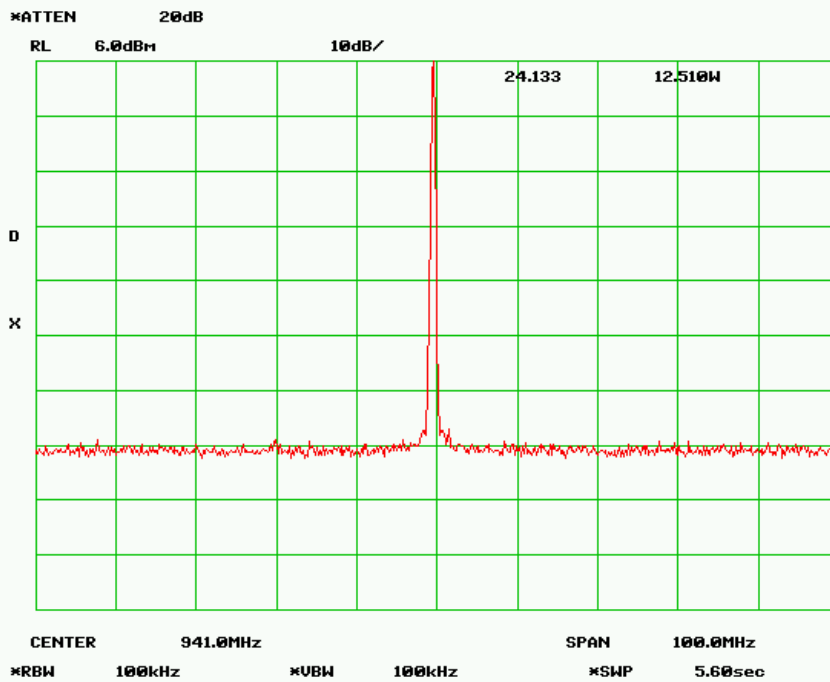
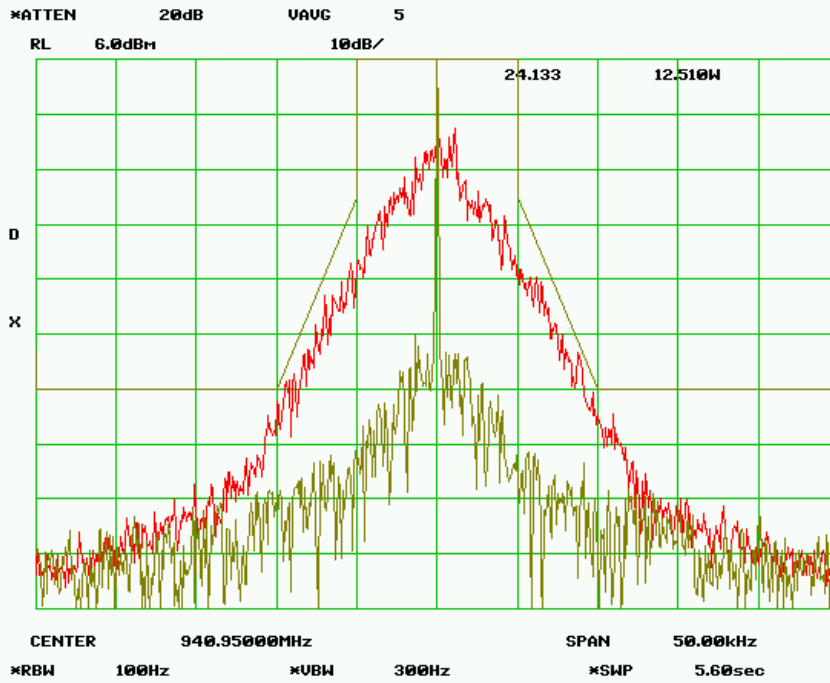

MASK 24.133a2 – 1.0 Watts
RF Frequency 940.950 MHz
SPECTRUM FOR EMISSION - 8K08F1D
 Data Rate = 32 kbps
 PEAK DEVIATION = 3.728 kHz

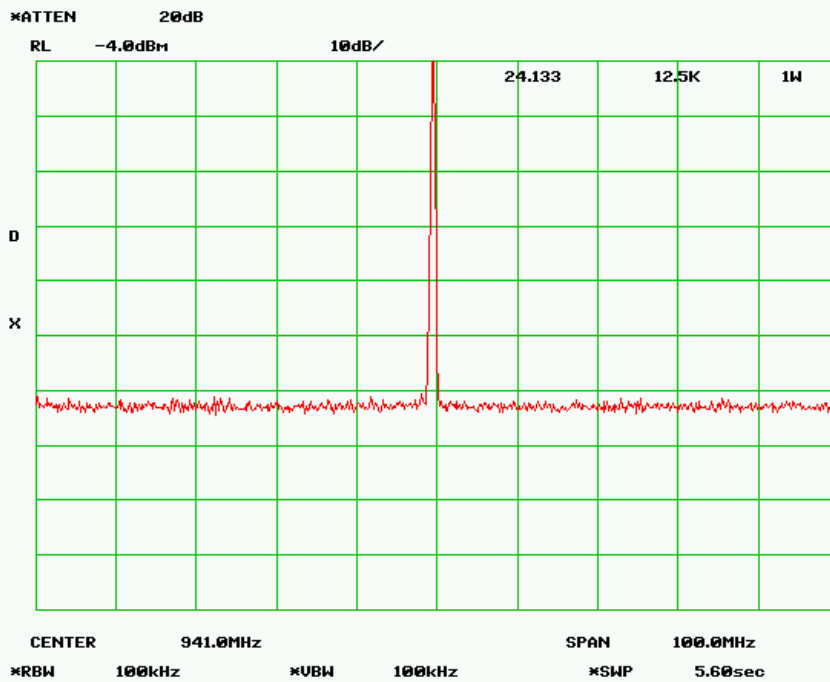
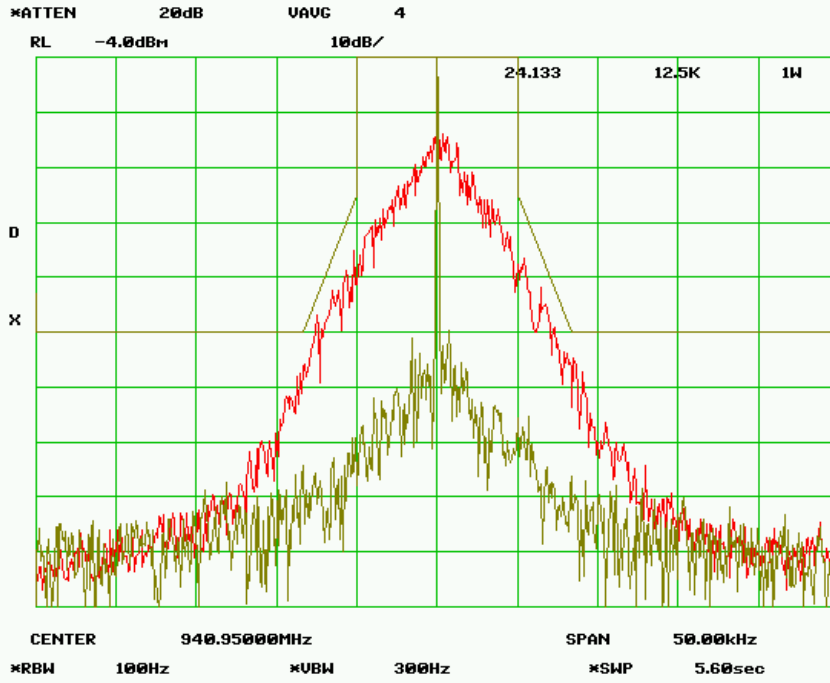

MASK 24.133a2 – 10.0 Watts
RF Frequency 940.950 MHz
SPECTRUM FOR EMISSION - 8K08F1D
Data Rate = 32 kbps
PEAK DEVIATION = 3.728 kHz

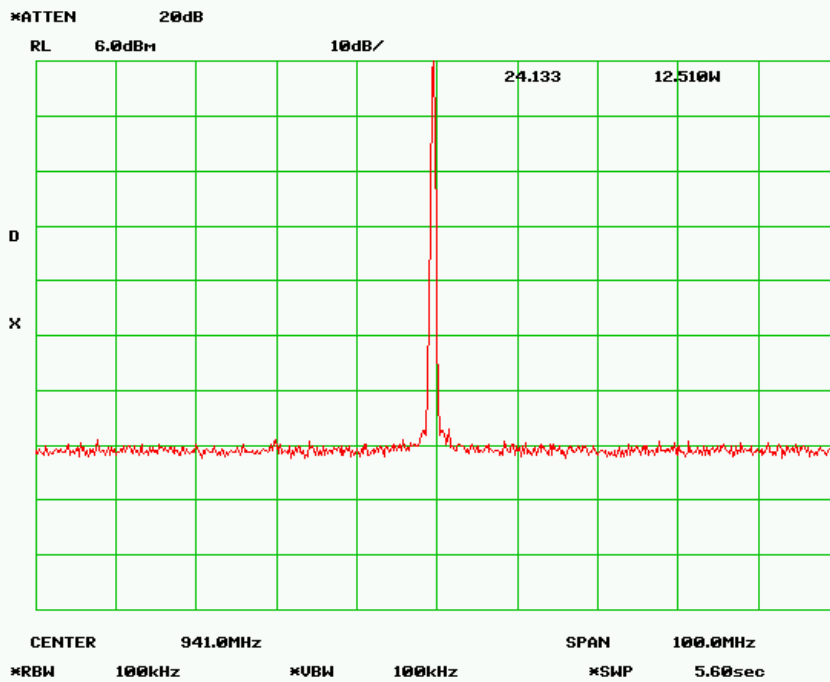
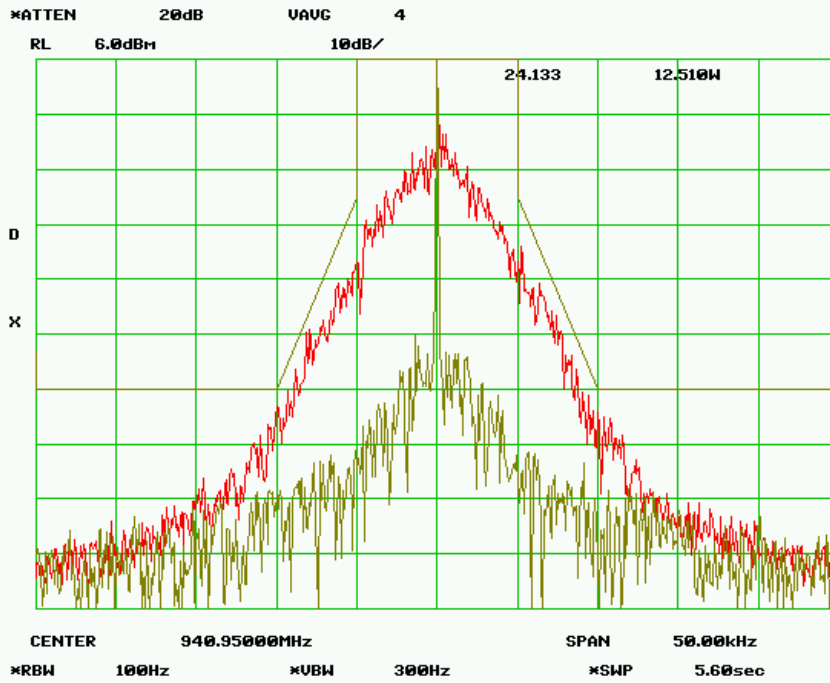

15.0 Part 24.133(a)(1) – 20 kHz ABW

NAME OF TEST: Transmitter Occupied Bandwidth for Emission Designators
16K5F1D, 16K8F1D, 17K8F1D, and 17K0F1D

RULE PART NUMBER: FCC: 2.202, 2.1049 (c) (1), 24.131, 24.133(a)(1)

MINIMUM STANDARDS: **Mask 24.133(a)(1) 25 kHz Channel**
Sidebands and Spurious [P = 10 Watts and P=1 Watt]
Authorized Bandwidth = 20 kHz
From Fo to 10 kHz, down 0 dB.
From 10 kHz to 50 kHz, down $116 * \log_{10}(f_d + 10 / 6.1)$ dB, 50+10log(P) or 70 dB.
Greater than 50 kHz, 43+10log₁₀(P) or 80 dB.

Attenuation = 0 db at Fo to 10 kHz
Attenuation = 25 dB at 10 kHz
Attenuation = 60 dB at 20 kHz @ 10W
Attenuation = 50 dB at 16.45 kHz @ 1W
Attenuation = 53 dB at 50 kHz @ 10W
Attenuation = 43 dB at 50 kHz @ 1W

TEST RESULTS: Meets minimum standards (see data on following page)

TEST CONDITIONS: Standard Test Conditions, 25 C
RF Power Level = 1 Watt and 10 Watts
Voltage = 20VDC

TEST PROCEDURE: TIA/EIA – 603-C

TEST EQUIPMENT: 50-Ohm Attenuator, Bird Electronics 50-A-FFN-20 (20dB, 50W)
50-Ohm Attenuator, Bird Electronics 10-A-MFN-10 (10dB, 10W)
50-Ohm Attenuator, Pasternack PE7002-10 (10dB)
Power Supply, Instek Model GPS-2303
Spectrum Analyzer, Hewlett Packard Model HP8563E
Modulation Analyzer, Hewlett Packard Model HP8901A

TEST SET-UP:

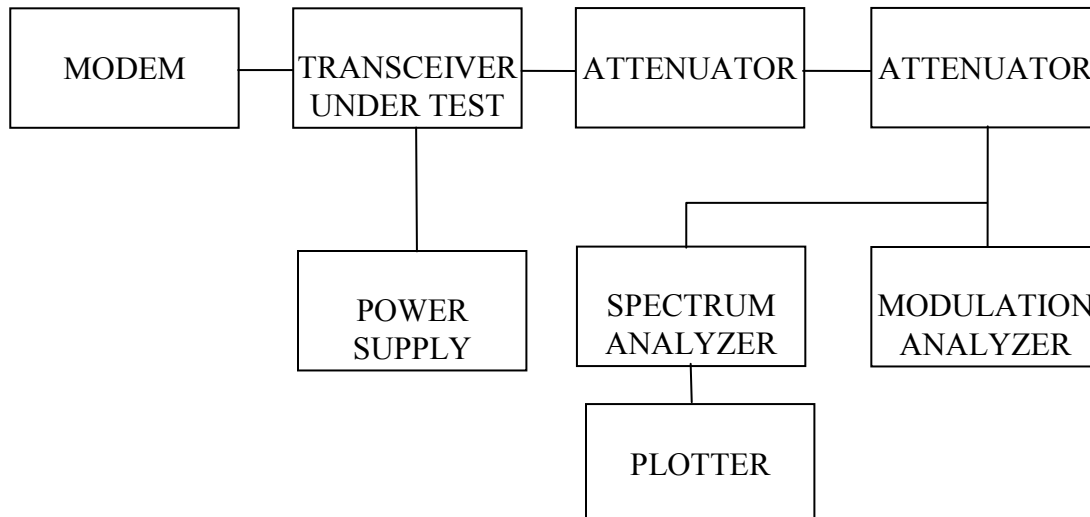

MASK 24.133a1 - 1.0 Watt
RF Frequency 940.950 MHz
SPECTRUM FOR EMISSION - 16K5F1D
Data Rate =16 kbps
PEAK DEVIATION = 6.30 kHz

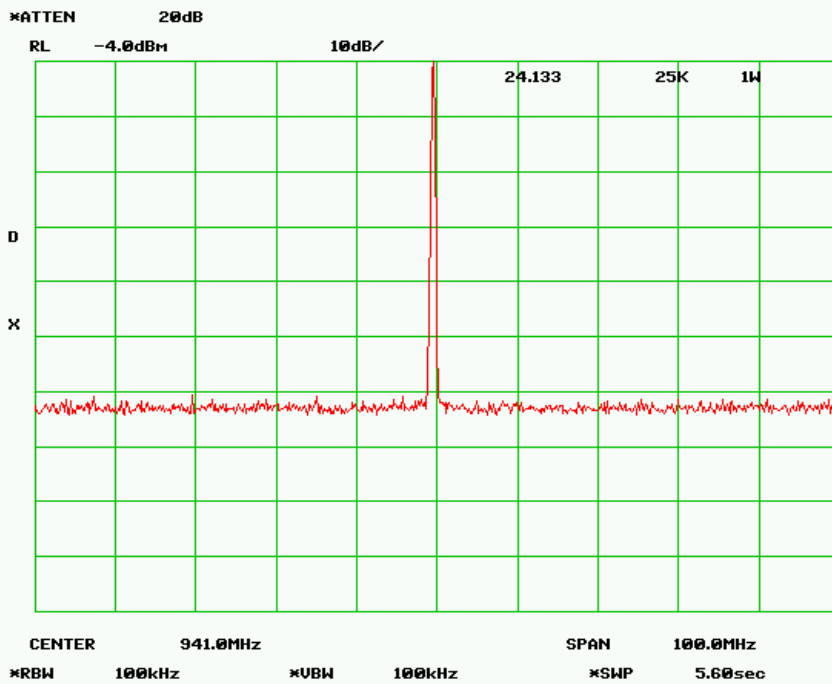
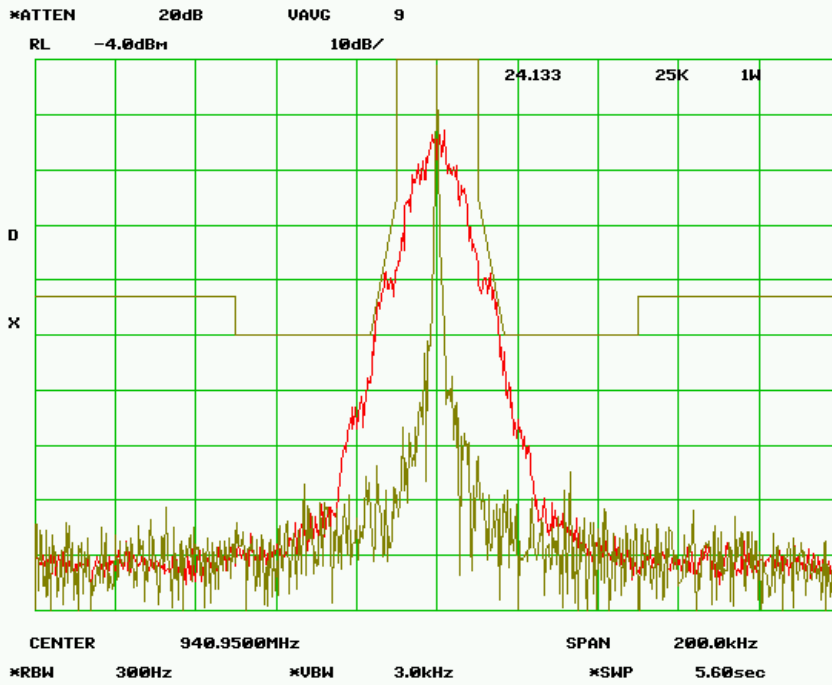

MASK 24.133a1 - 10.0 Watt
RF Frequency 940.950 MHz
SPECTRUM FOR EMISSION - 16K5F1D
Data Rate = 16 kbps
PEAK DEVIATION = 6.30 kHz

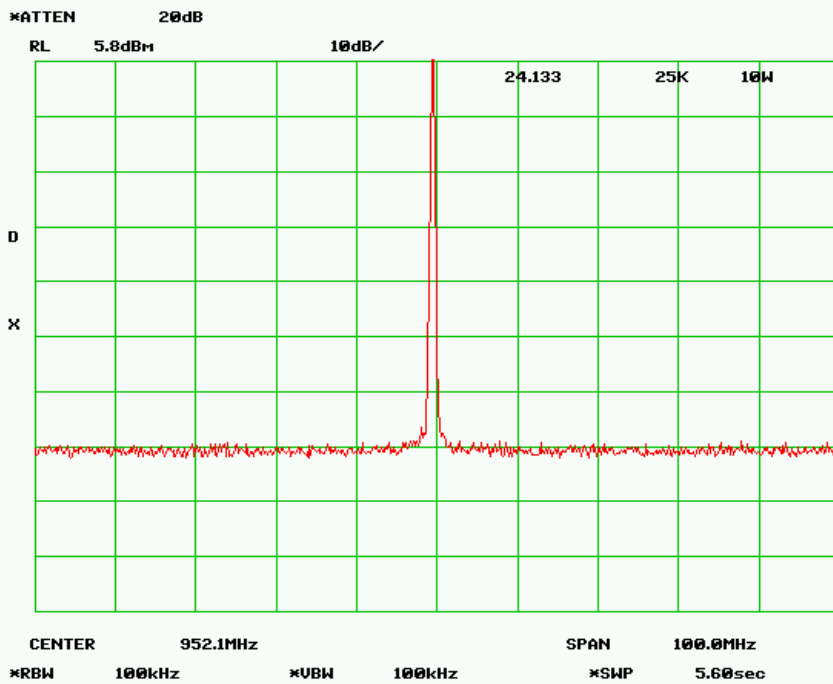
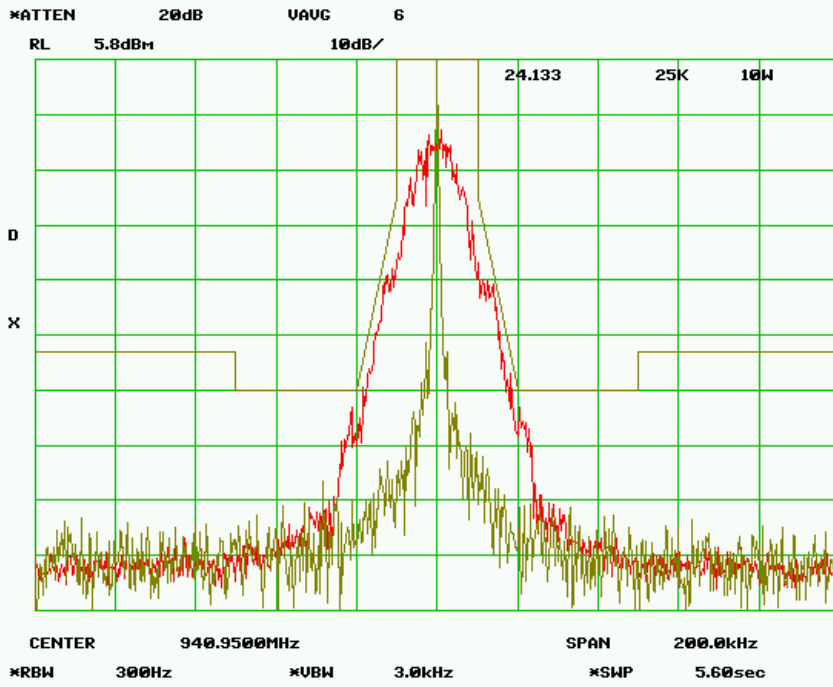

MASK 24.133a1 - 1.0 Watt
RF Frequency 940.950 MHz
SPECTRUM FOR EMISSION - 16K8F1D
 Data Rate = 32 kbps
 PEAK DEVIATION = 6.30 kHz

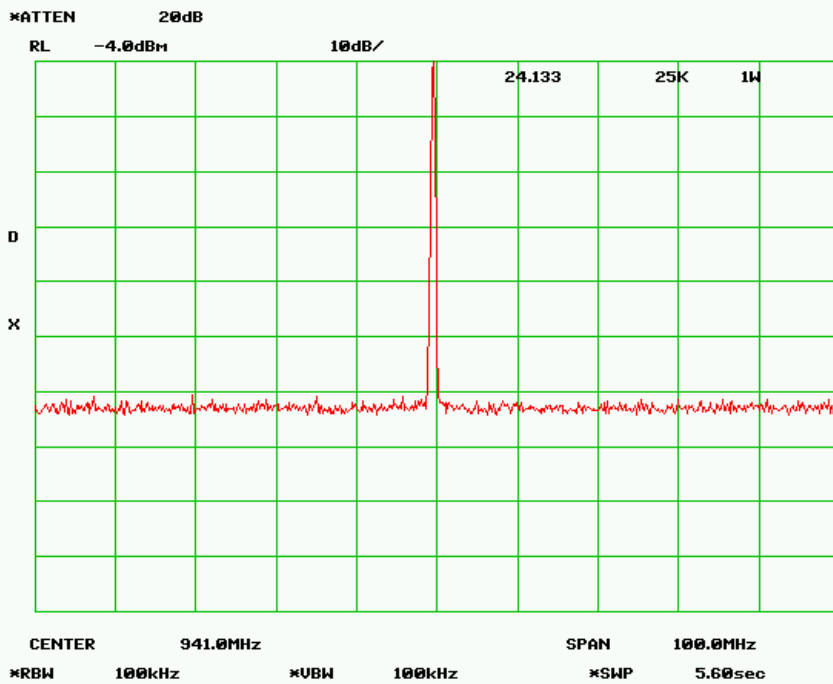
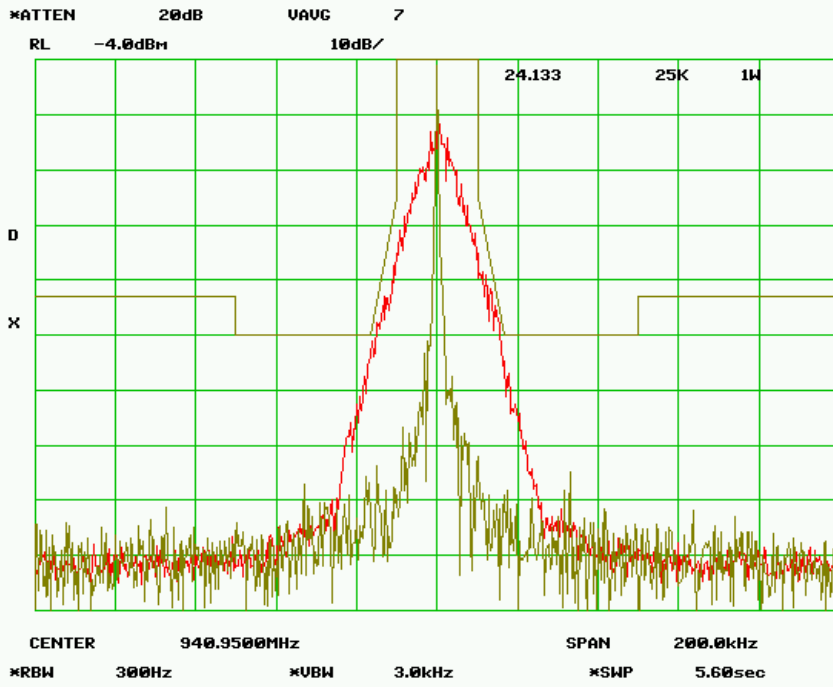

MASK 24.133a1 - 10 Watts
RF Frequency 940.950 MHz
SPECTRUM FOR EMISSION - 16K8F1D
Data Rate = 32 kbps
PEAK DEVIATION = 6.30 kHz

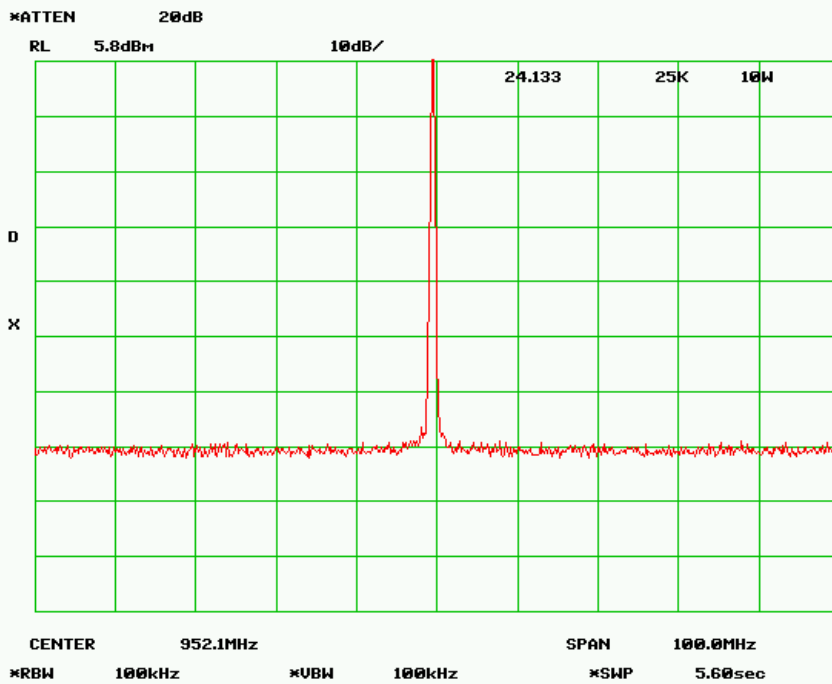
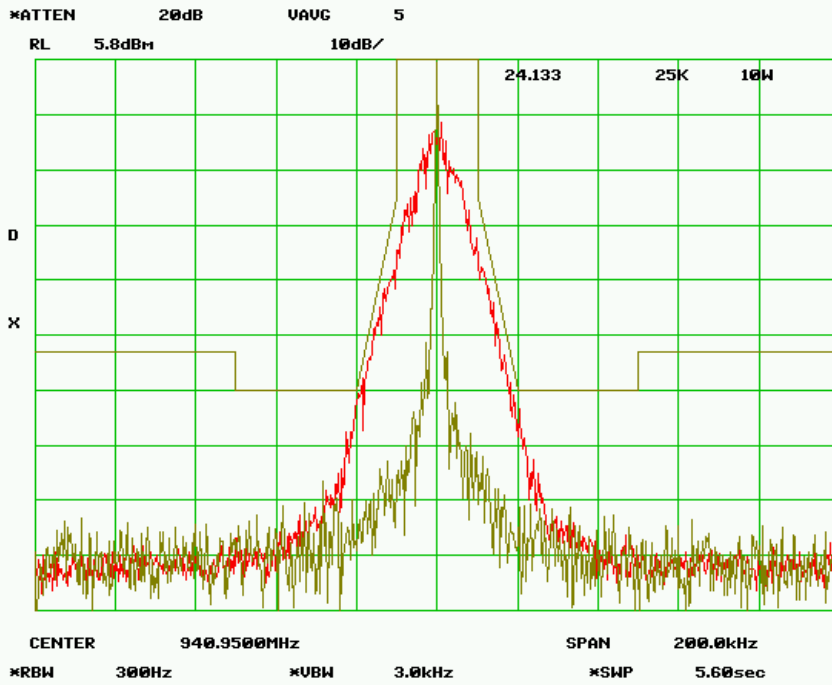

MASK 24.133a1 - 1.0 Watt
RF Frequency 940.950 MHz
SPECTRUM FOR EMISSION - 17K8F1D
Data Rate = 48 kbps
PEAK DEVIATION = 7.59 kHz

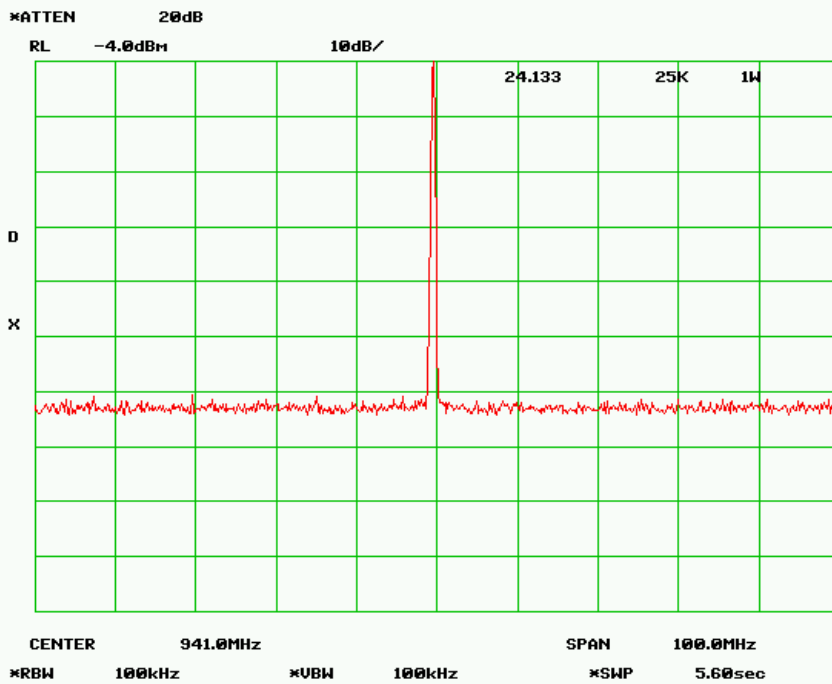
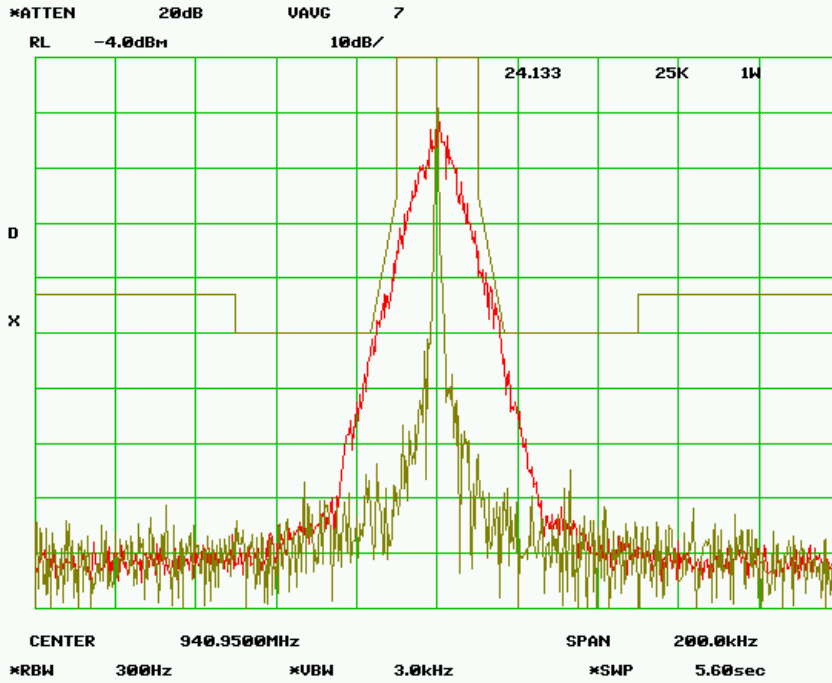

MASK 24.133a1 - 10 Watts
RF Frequency 940.950 MHz
SPECTRUM FOR EMISSION - 17K8F1D
RF Frequency 940.950 MHz
PEAK DEVIATION = 7.59 kHz

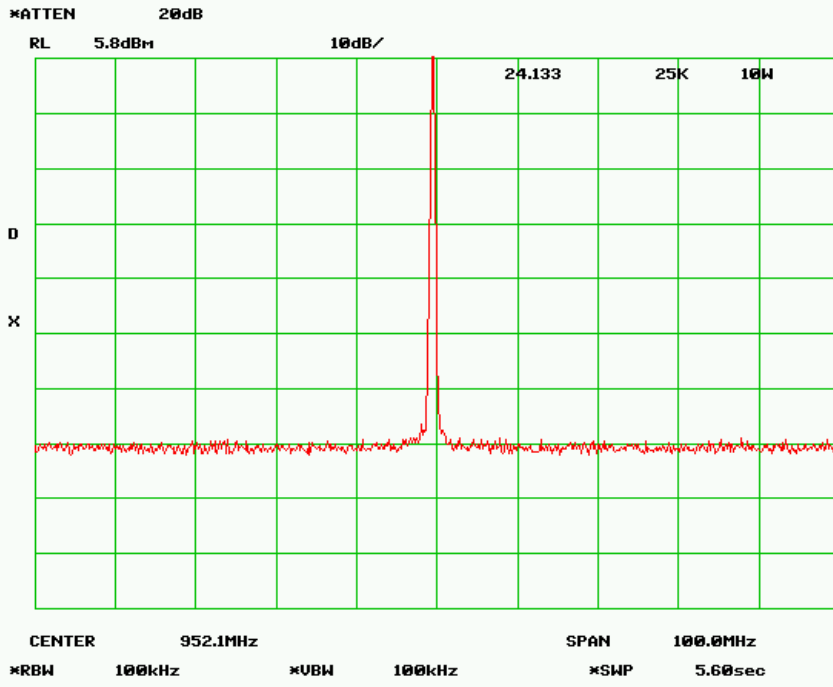
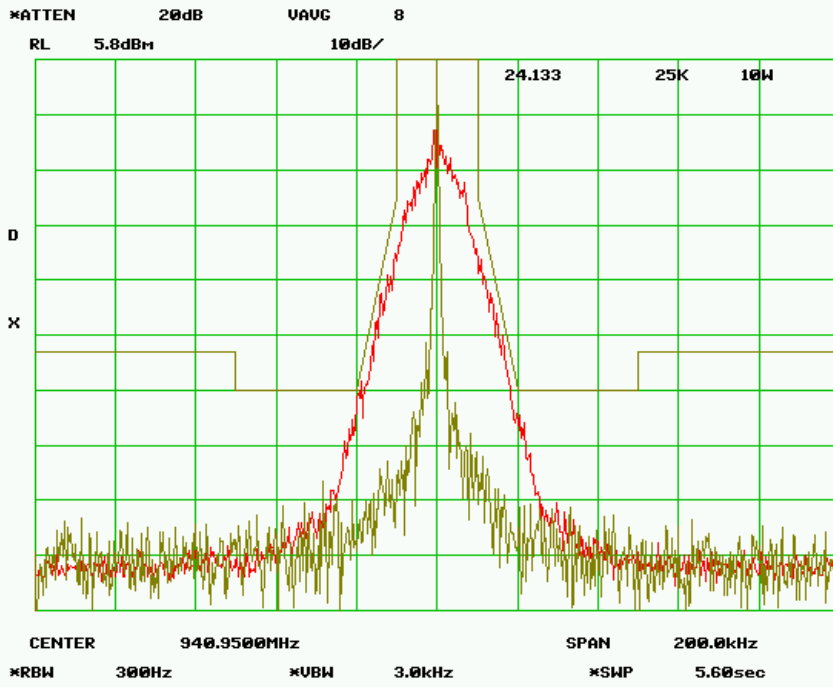

MASK 24.133a1 – 1.0 Watts
RF Frequency 940.950 MHz
SPECTRUM FOR EMISSION - 17K0F1D
Data Rate = 64 kbps
PEAK DEVIATION = 7.52 kHz

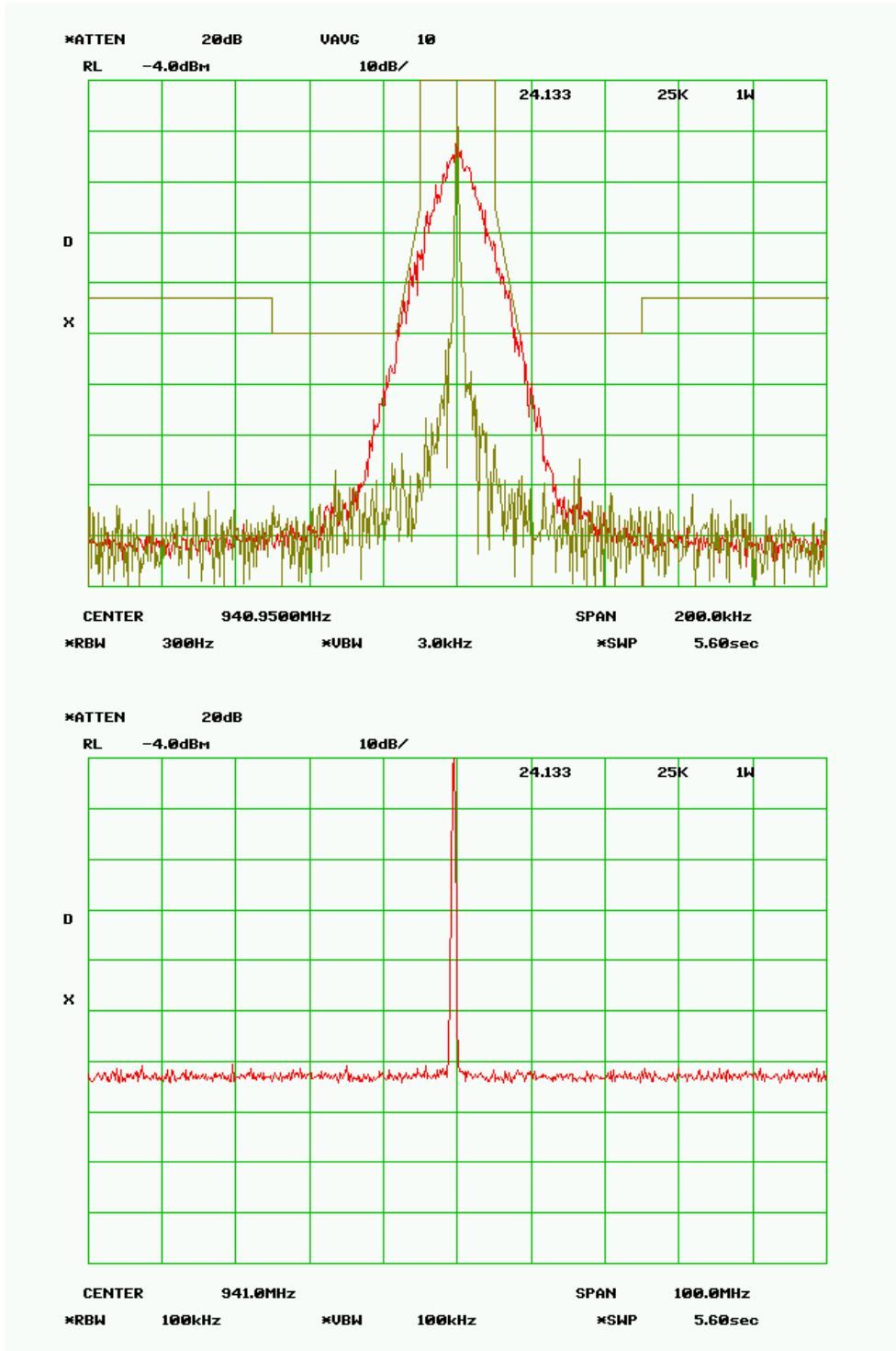

MASK 24.133a1 - 10 Watts
RF Frequency 940.950 MHz
SPECTRUM FOR EMISSION - 17K0F1D
 Data Rate = 64 kbps
 PEAK DEVIATION = 7.52 kHz

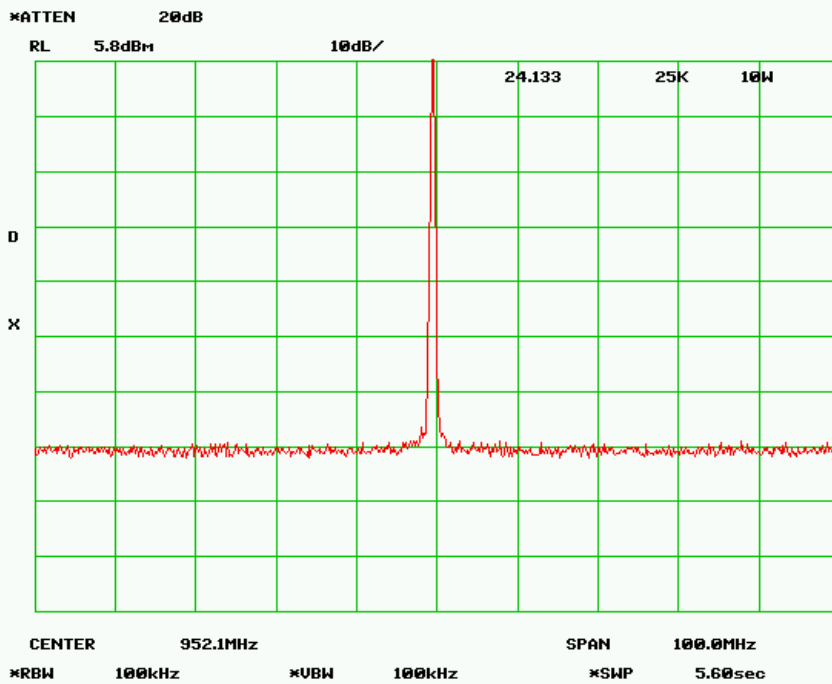
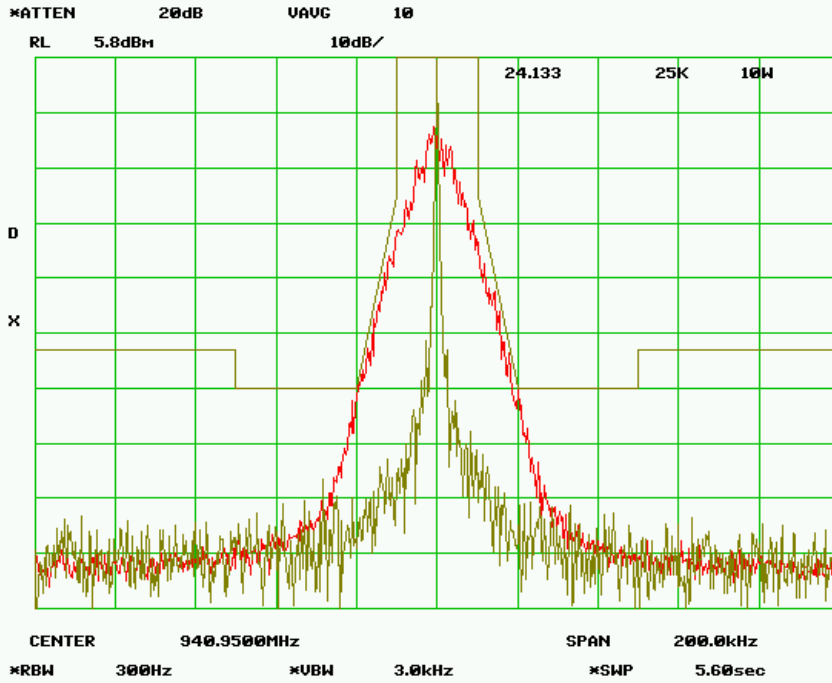

16.0 Part 24.133(a)(1) – 45 kHz ABW

NAME OF TEST: Transmitter Occupied Bandwidth for Emission Designators
29K8F1D, 30K0F1D, 29K5F1D, 30K5F1D

RULE PART NUMBER: FCC: 2.202, 2.1049 (c) (1), 24.131, 24.133(a)(1)

MINIMUM STANDARDS: **Mask 24.133(a)(1) 50 kHz Channel**
Sidebands and Spurious [P = 10 Watts and P=1 Watt]
Authorized Bandwidth = 45 kHz
From Fo to 22.5 kHz, down 0 dB.
From 22.5 kHz to 62.5 kHz, down $116 * \log_{10}(f_d + 10 / 6.1)$ dB, $50 + 10 \log(P)$ or 70 dB.
Greater than 62.5 kHz, $43 + 10 \log_{10}(P)$ or 80 dB.

Attenuation = 0 db at Fo to 22.5 kHz
Attenuation = 25 dB at 22.5 kHz
Attenuation = 60 dB at 32.5 kHz @ 10W
Attenuation = 50 dB at 29.0 kHz @ 1W
Attenuation = 53 dB at 62.5 kHz @ 10W
Attenuation = 43 dB at 62.5 kHz @ 1W

TEST RESULTS: Meets minimum standards (see data on following page)

TEST CONDITIONS: Standard Test Conditions, 25 C
RF Power Level = 1 Watt and 10 Watts
Voltage = 20VDC

TEST PROCEDURE: TIA/EIA – 603-C, 2.2.13, 3.2.11.2

TEST EQUIPMENT: 50-Ohm Attenuator, Bird Electronics Model 50-A-FFN-20 (20dB, 50W)
50-Ohm Attenuator, Bird Electronics Model 10-A-MFN-10 (10dB, 10W)
50-Ohm Attenuator, Pasternack Model PE7002-10 (10dB)
DC Power Supply, Hewlett Packard Model 6653A
Spectrum Analyzer, Hewlett Packard Model HP8563E
Modulation Analyzer, Hewlett Packard Model HP8901A

TEST SET-UP:

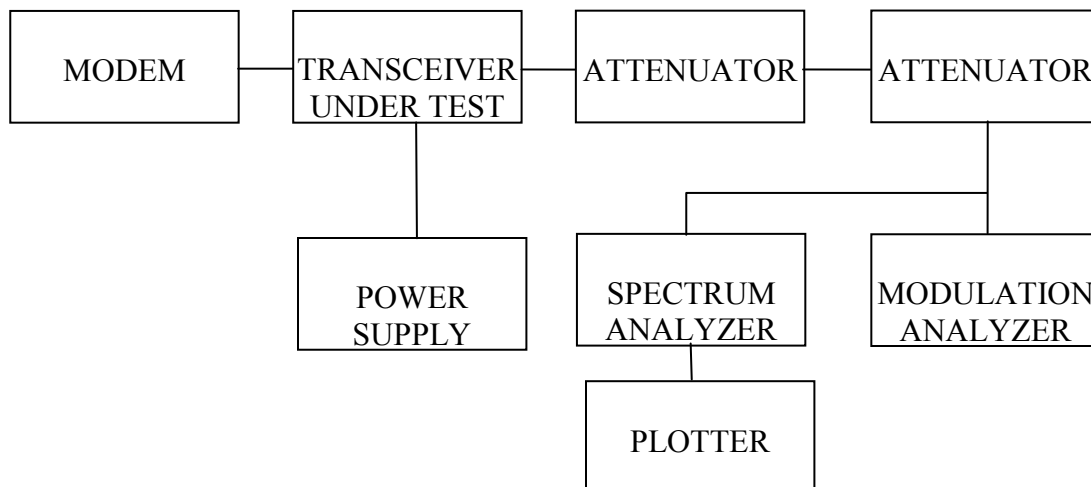

MASK 24.133a1 50kHz - 1.0 Watt
RF Frequency 940.950 MHz
SPECTRUM FOR EMISSION - 29K8F1D
Data Rate =32 kbps
PEAK DEVIATION = 9.36 kHz

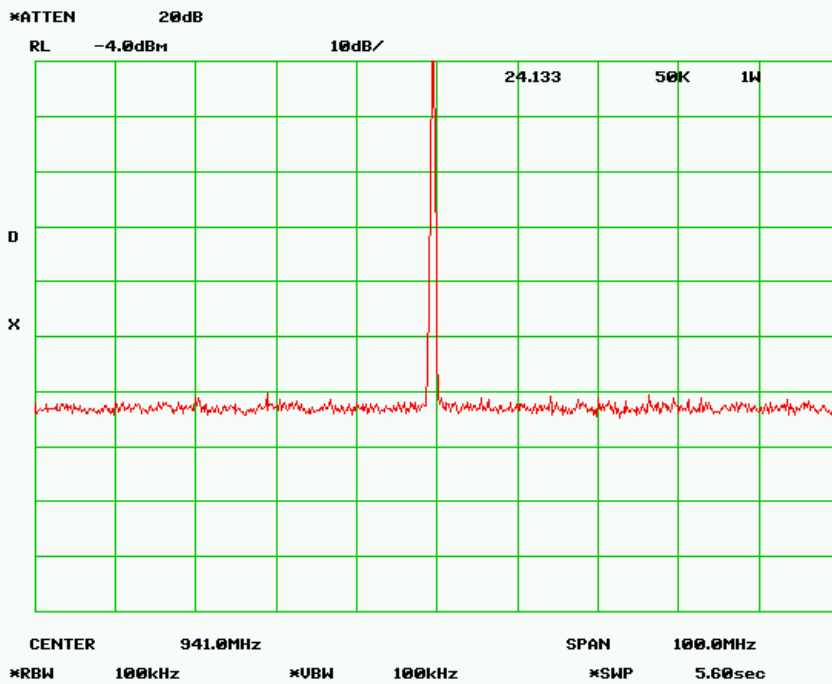
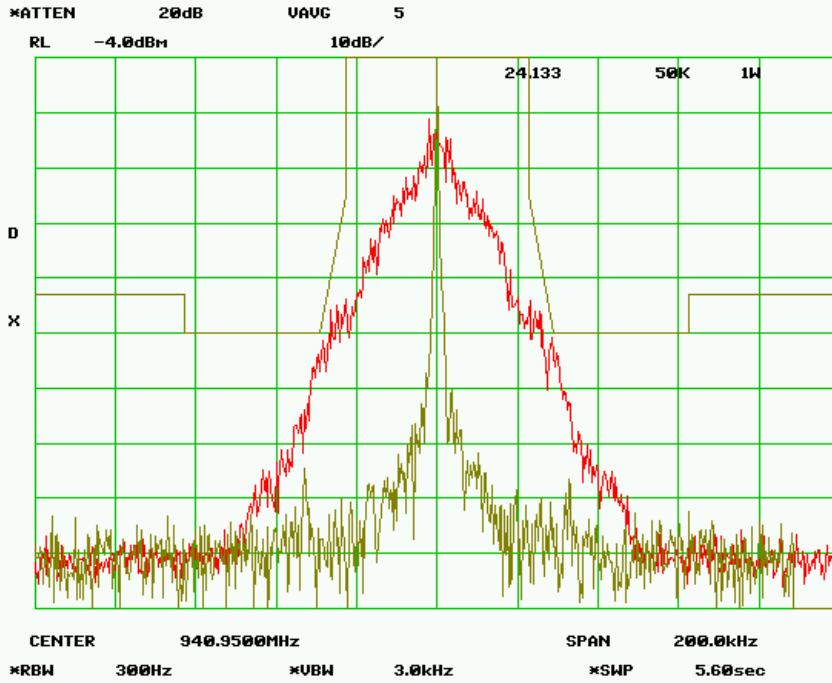

MASK 24.133a1 50kHz - 10.0 Watt
RF Frequency 940.950 MHz
SPECTRUM FOR EMISSION - 29K8F1D
Data Rate =32 kbps
PEAK DEVIATION = 9.36 kHz

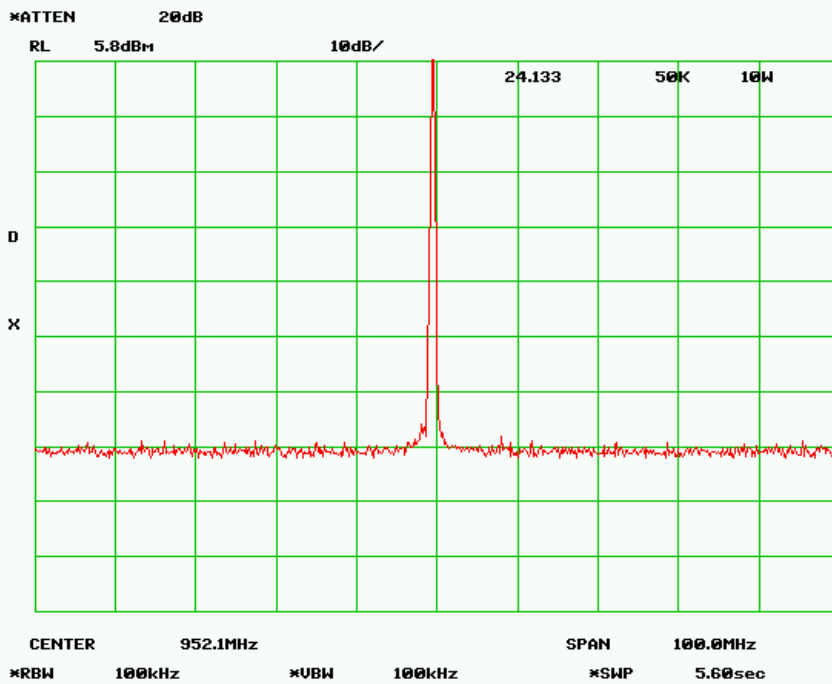
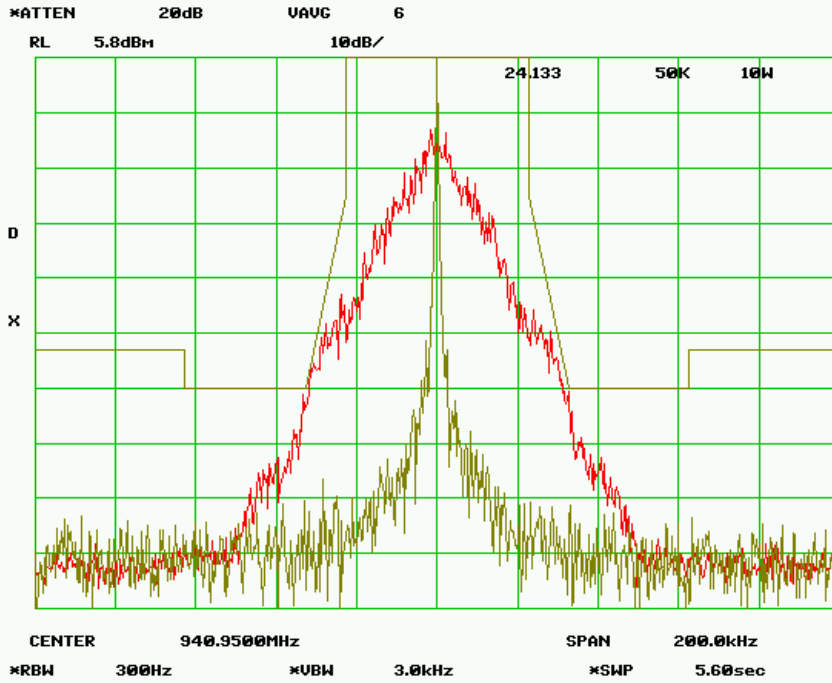

MASK 24.133a1 50kHz - 1.0 Watt
RF Frequency 940.950 MHz
SPECTRUM FOR EMISSION - 30K0F1D
Data Rate = 64 kbps
PEAK DEVIATION = 11.02 kHz

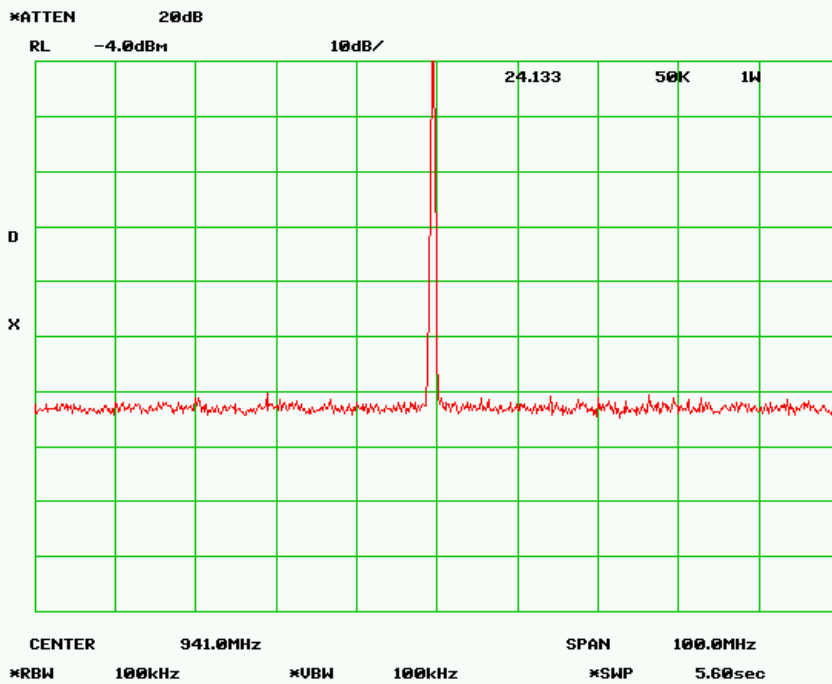
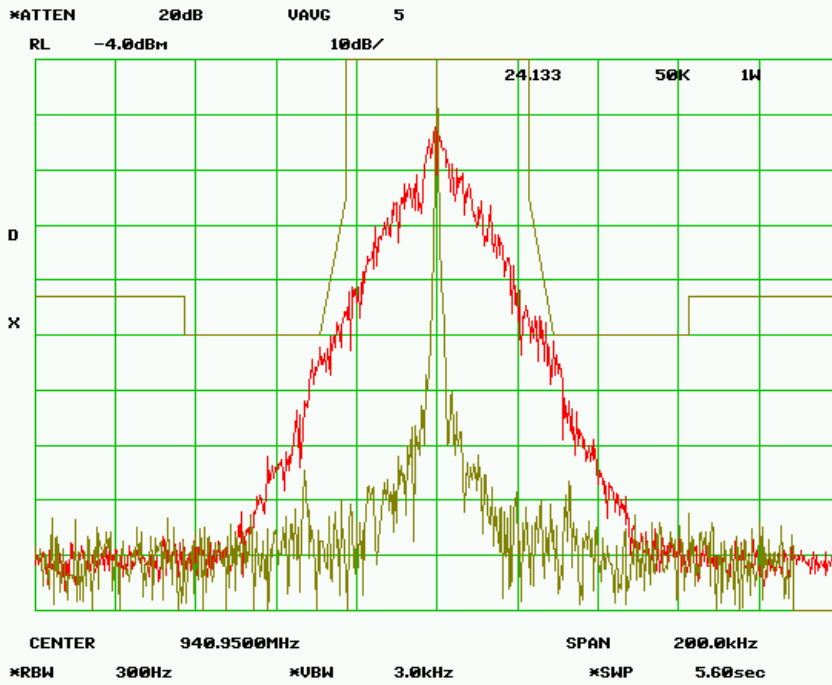

MASK 24.133a1 50kHz - 10 Watts
RF Frequency 940.950 MHz
SPECTRUM FOR EMISSION - 30K0F1D
Data Rate = 64 kbps
PEAK DEVIATION = 11.02 kHz

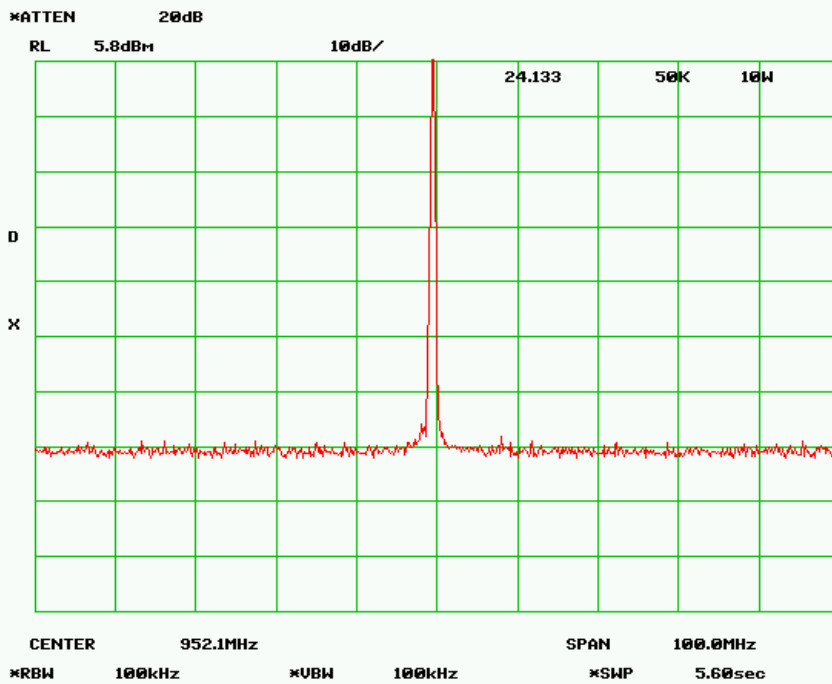
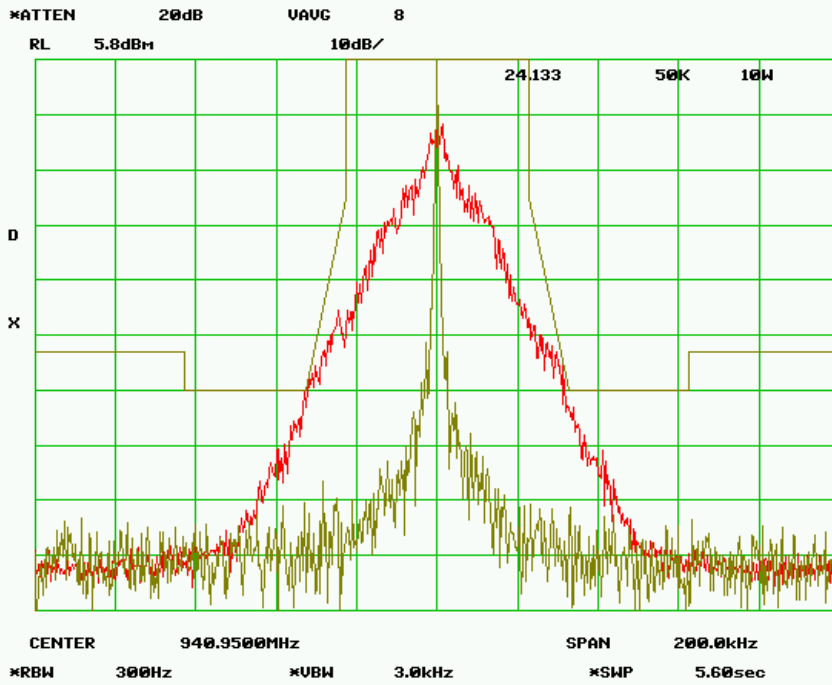

MASK 24.133a1 50kHz - 1.0 Watt
RF Frequency 940.950 MHz
SPECTRUM FOR EMISSION - 29K5F1D
 Data Rate = 96 kbps
 PEAK DEVIATION = 10.81 kHz

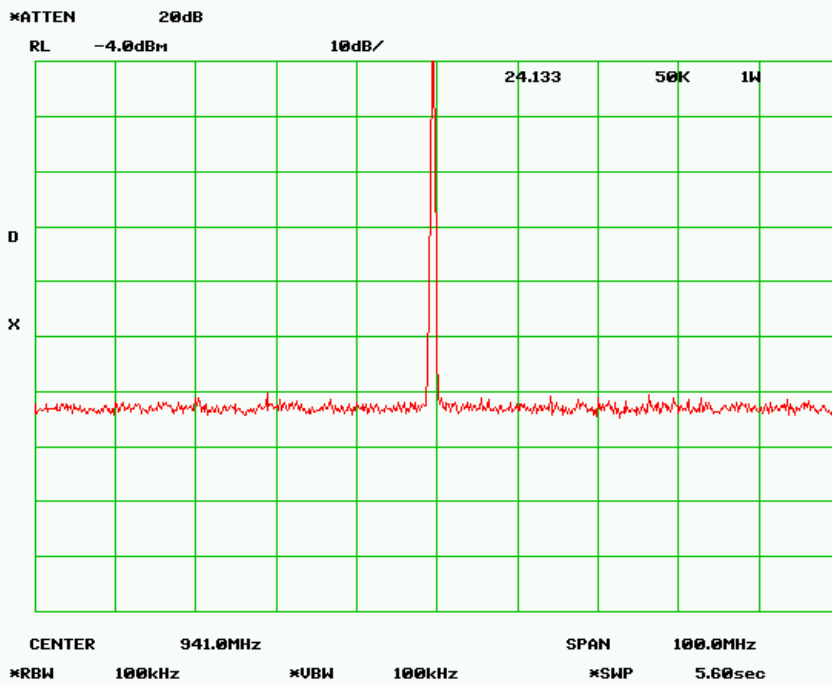
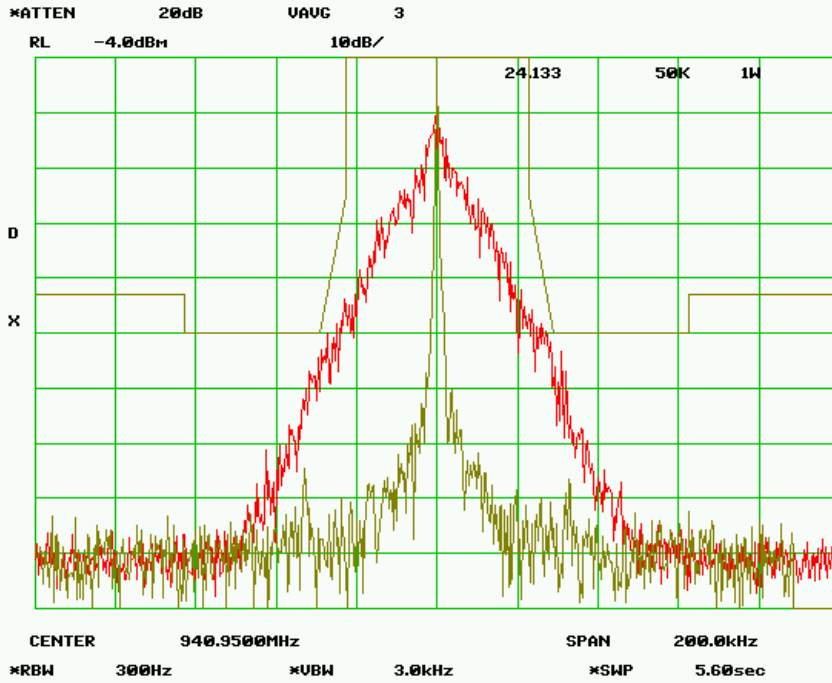

MASK 24.133a1 50kHz - 10 Watts
RF Frequency 940.950 MHz
SPECTRUM FOR EMISSION - 29K5F1D
Data Rate = 96 kbps
PEAK DEVIATION = 10.81 kHz

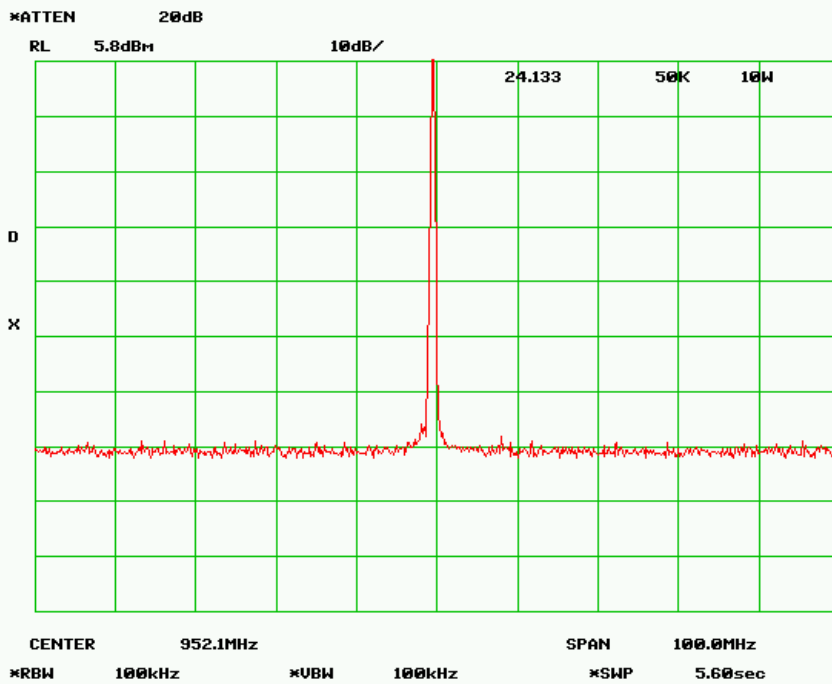
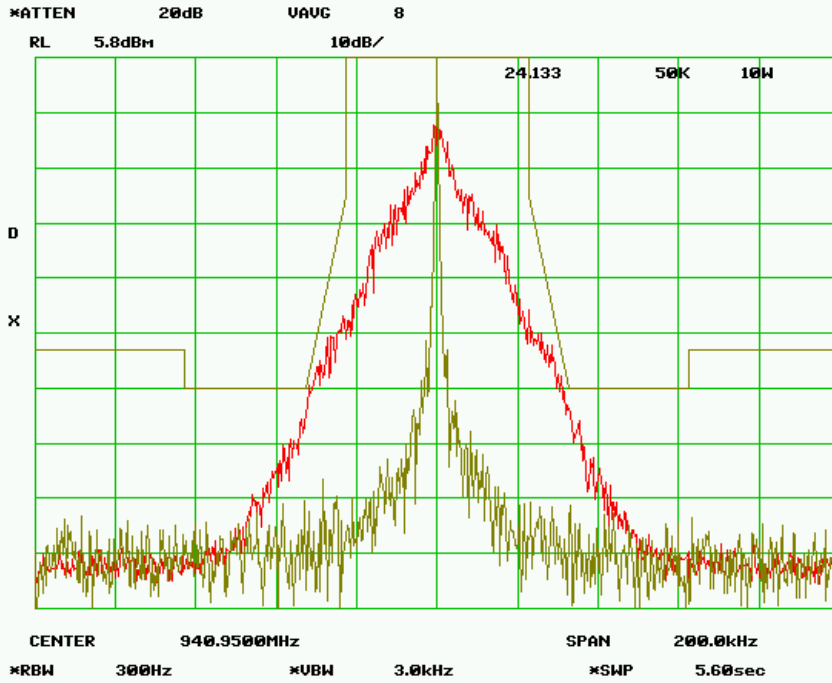

MASK 24.133a1 50kHz - 1.0 Watt
RF Frequency 940.950 MHz
SPECTRUM FOR EMISSION - 30K5F1D
 Data Rate = 128 kbps
 PEAK DEVIATION = 11.66 kHz

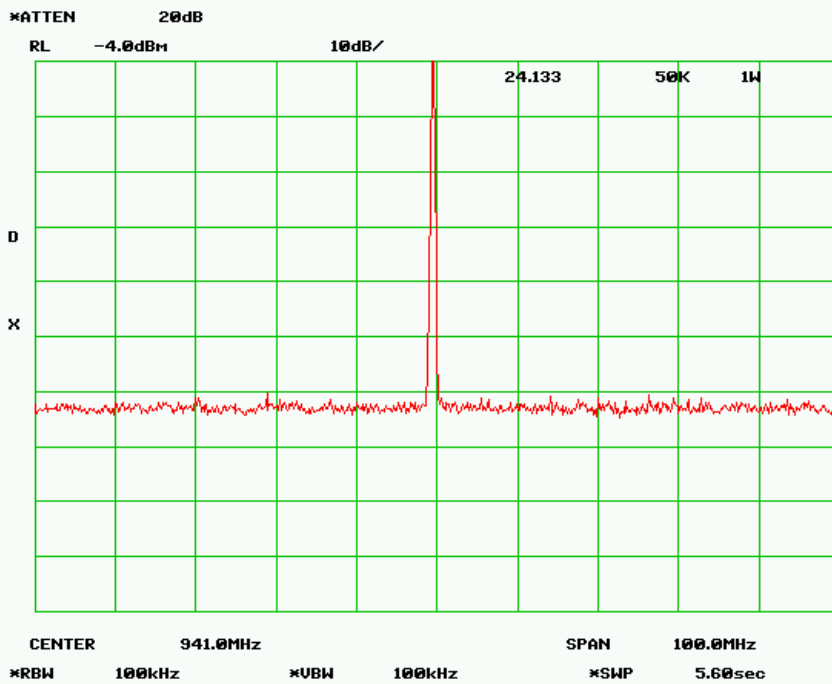
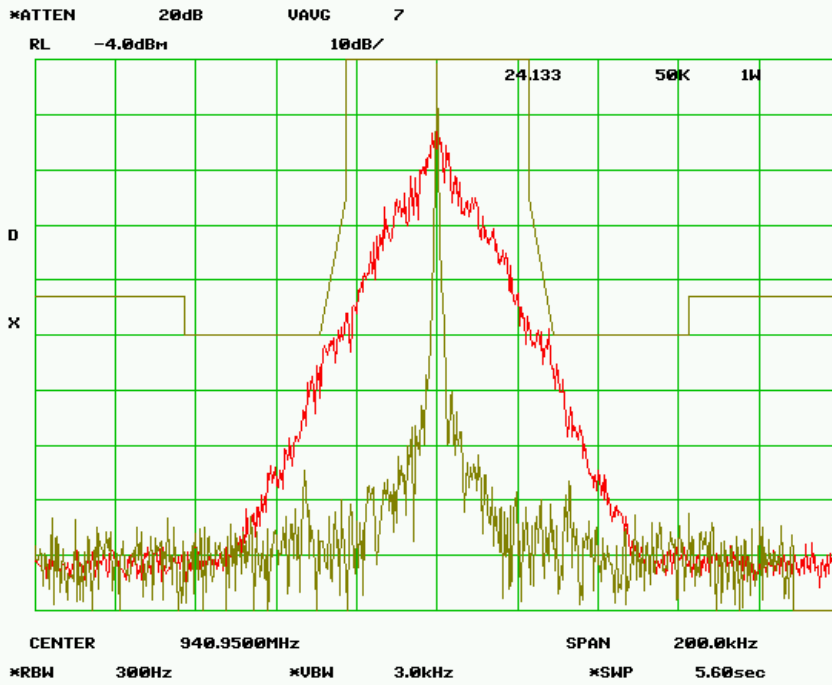

MASK 24.133a1 50kHz - 10 Watts
RF Frequency 940.950 MHz
SPECTRUM FOR EMISSION - 30K5F1D
Data Rate = 128 kbps
PEAK DEVIATION = 11.66 kHz

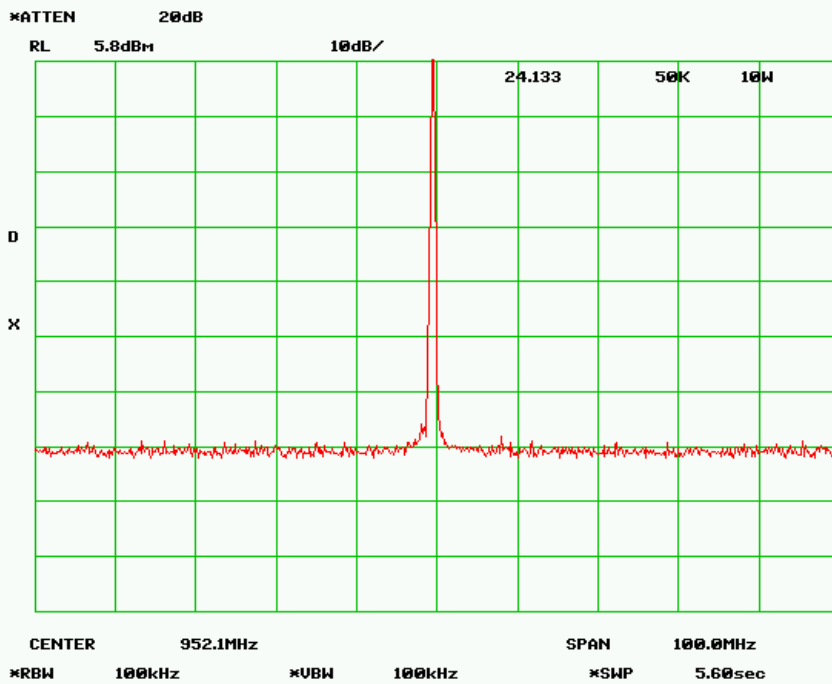
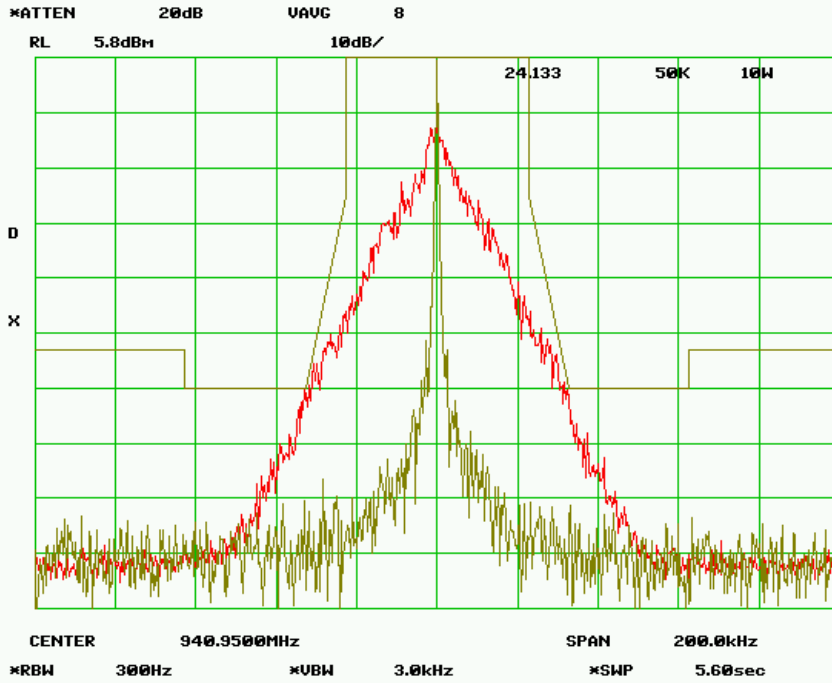

17.0 Part 24.133(a)(1) – 95 kHz ABW

NAME OF TEST: Transmitter Occupied Bandwidth for Emission Designators
51K0F1D, 52K7F1D, 49K7F1D, 51K3F1D

RULE PART NUMBER: FCC: 2.202, 2.1049 (c) (1), 24.131, 24.133(a)(1)

MINIMUM STANDARDS: **Mask 24.133(a)(1) 100 kHz Channel**
Sidebands and Spurious [P = 10 Watts and P=1 Watt]
Authorized Bandwidth = 95 kHz
From Fo to 22.5 kHz, down 0 dB.
From 47.5 kHz to 87.5 kHz, down $116 * \log_{10}(f_d + 10 / 6.1)$ dB, $50 + 10\log(P)$ or 70 dB.
Greater than 87.5 kHz, $43 + 10\log_{10}(P)$ or 80 dB.

Attenuation = 0 db at Fo to 47.5 kHz
Attenuation = 25 dB at 47.5 kHz
Attenuation = 60 dB at 57.6 kHz @ 10W
Attenuation = 50 dB at 54.0 kHz @ 1W
Attenuation = 53 dB at 87.5 kHz @ 10W
Attenuation = 43 dB at 87.5 kHz @ 1W

TEST RESULTS: Meets minimum standards (see data on following page)

TEST CONDITIONS: Standard Test Conditions, 25 C
RF Power Level = 1 Watt and 10 Watts
Voltage = 20VDC

TEST PROCEDURE: TIA/EIA – 603-C, 2.2.13, 3.2.11.2

TEST EQUIPMENT: 50-Ohm Attenuator, Bird Electronics Model 50-A-FFN-20 (20dB, 50W)
50-Ohm Attenuator, Bird Electronics Model 10-A-MFN-10 (10dB, 10W)
50-Ohm Attenuator, Pasternack Model PE7002-10 (10dB)
DC Power Supply, Hewlett Packard Model 6653A
Spectrum Analyzer, Hewlett Packard Model HP8563E
Modulation Analyzer, Hewlett Packard Model HP8901A

TEST SET-UP:

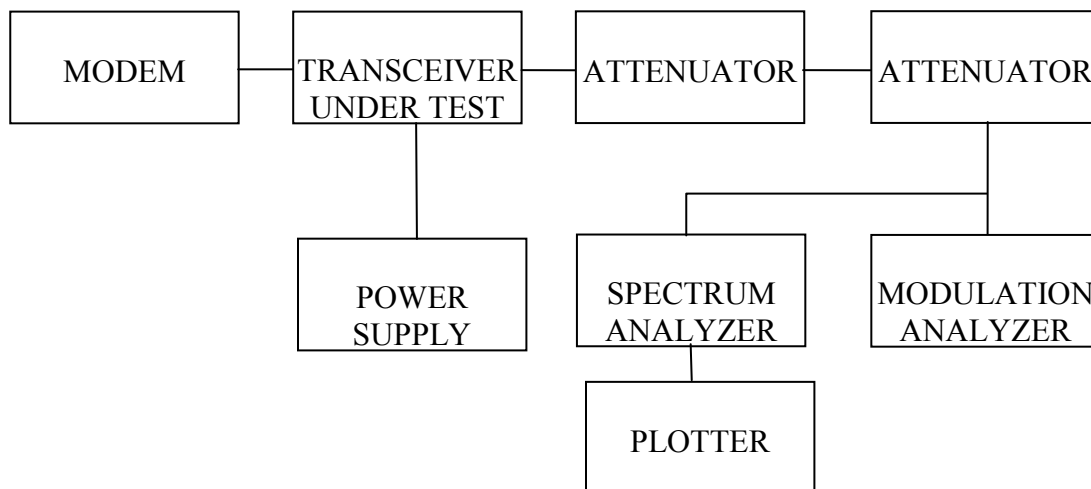

MASK 24.133a1 100 kHz - 1.0 Watt
RF Frequency 940.950 MHz
SPECTRUM FOR EMISSION - 51K0F1D
Data Rate =64 kbps
PEAK DEVIATION = 10.81kHz

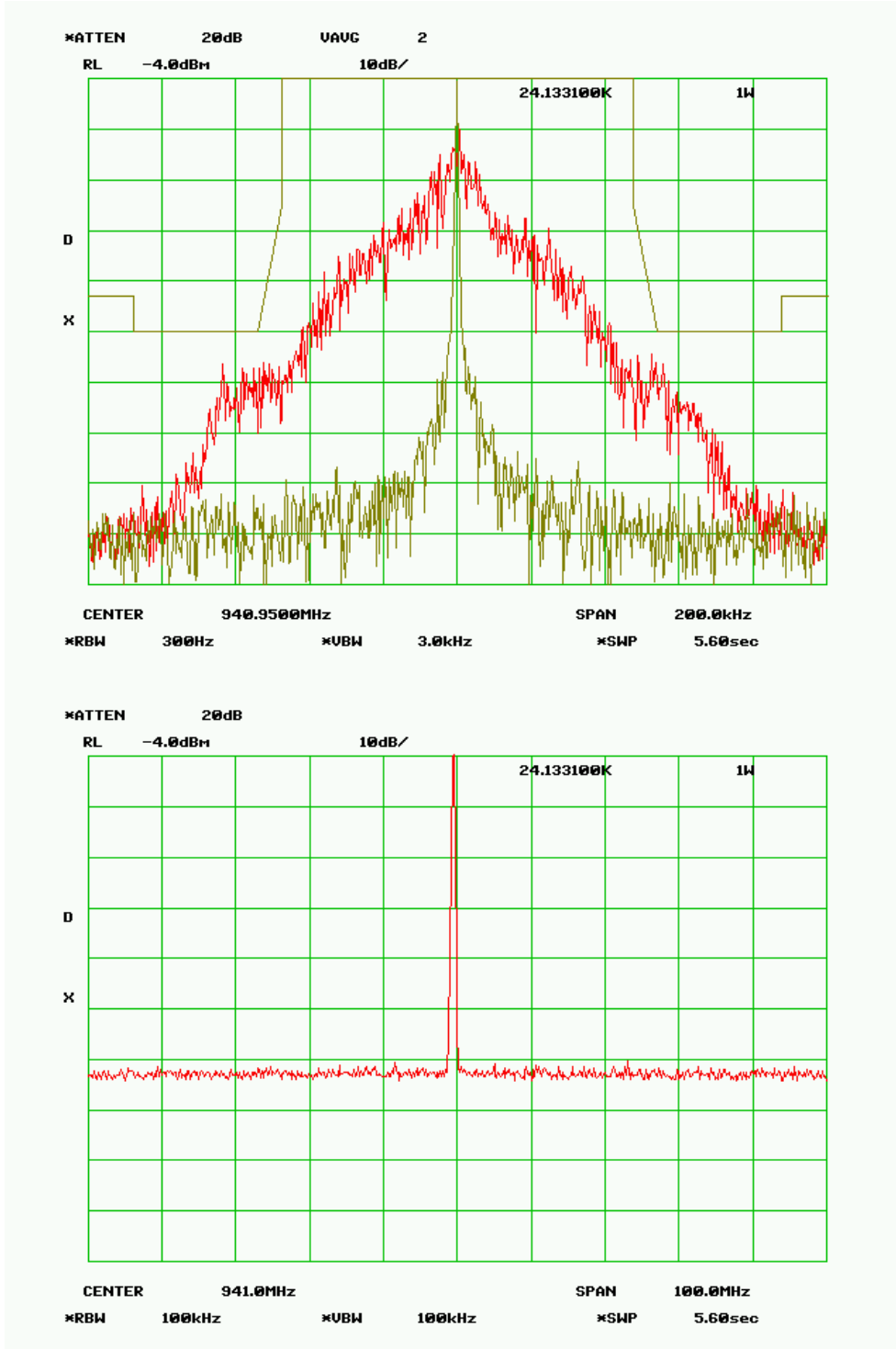

MASK 24.133a1 100 kHz - 10.0 Watt
RF Frequency 940.950 MHz
SPECTRUM FOR EMISSION - 51K0F1D
Data Rate =64 kbps
PEAK DEVIATION = 10.81kHz

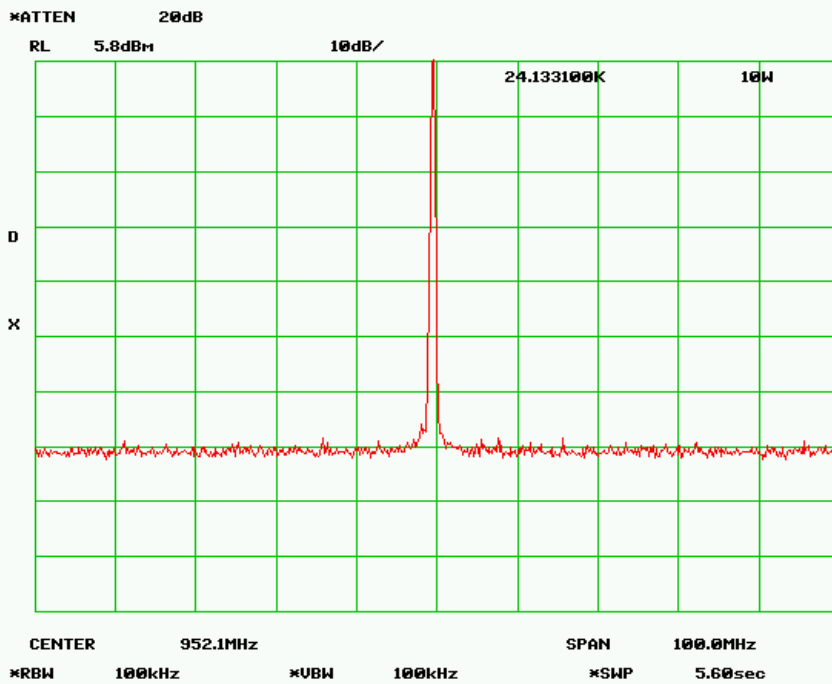
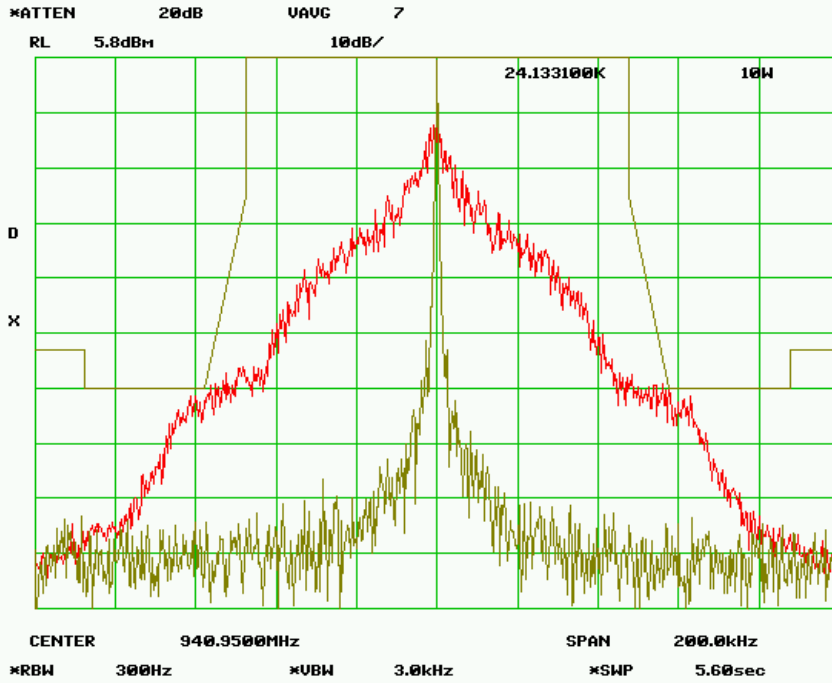

MASK 24.133a1 100 kHz - 1.0 Watt
RF Frequency 940.950 MHz
SPECTRUM FOR EMISSION - 52K7F1D
Data Rate = 128 kbps
PEAK DEVIATION = 12.40kHz

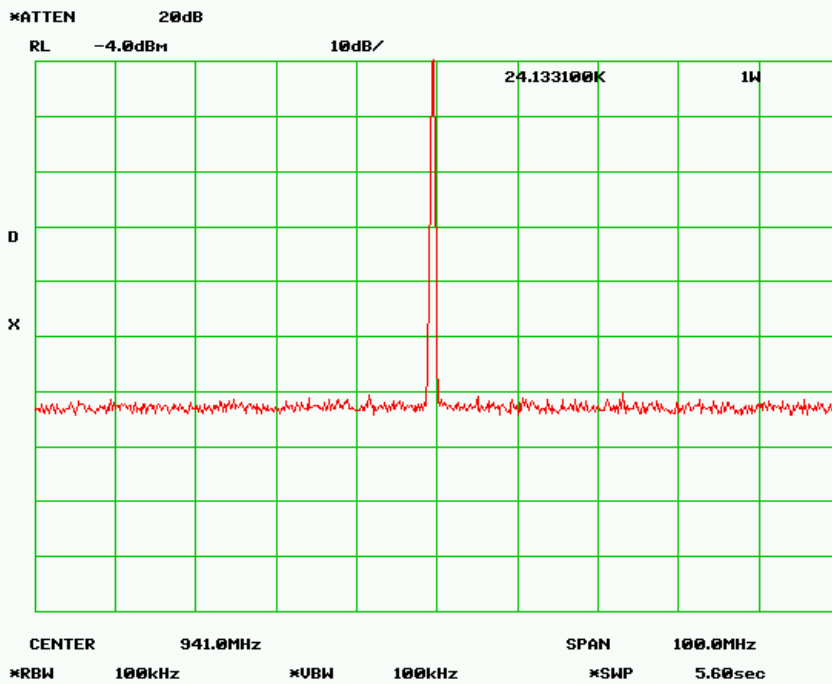
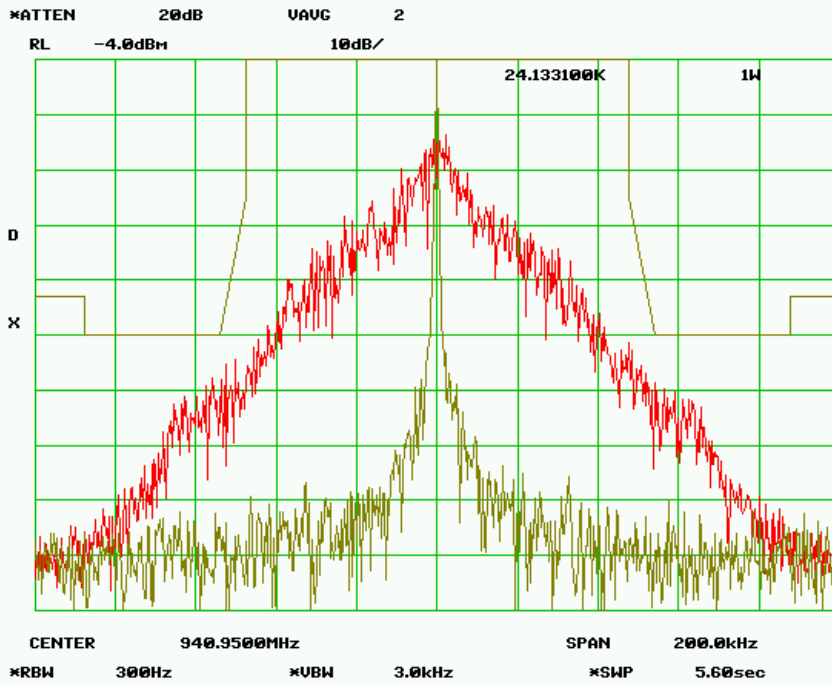

MASK 24.133a1 100 kHz - 10 Watts
RF Frequency 928.050 MHz
SPECTRUM FOR EMISSION - 52K7F1D
Data Rate = 128 kbps
PEAK DEVIATION = 12.40kHz

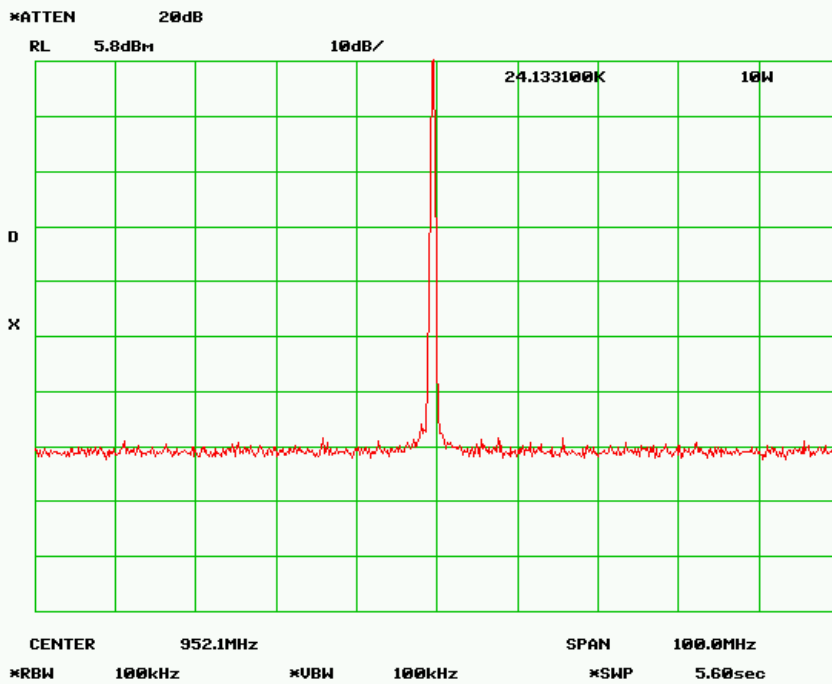
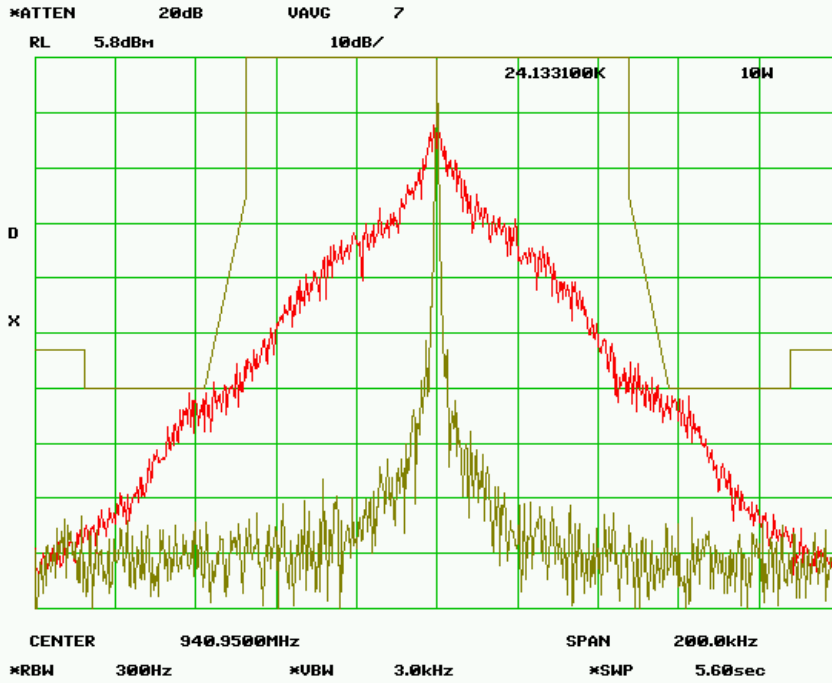

MASK 24.133a1 100 kHz - 1.0 Watt
RF Frequency 940.950 MHz
SPECTRUM FOR EMISSION - 49K7F1D
Data Rate = 192kbps
PEAK DEVIATION = 13.02 kHz

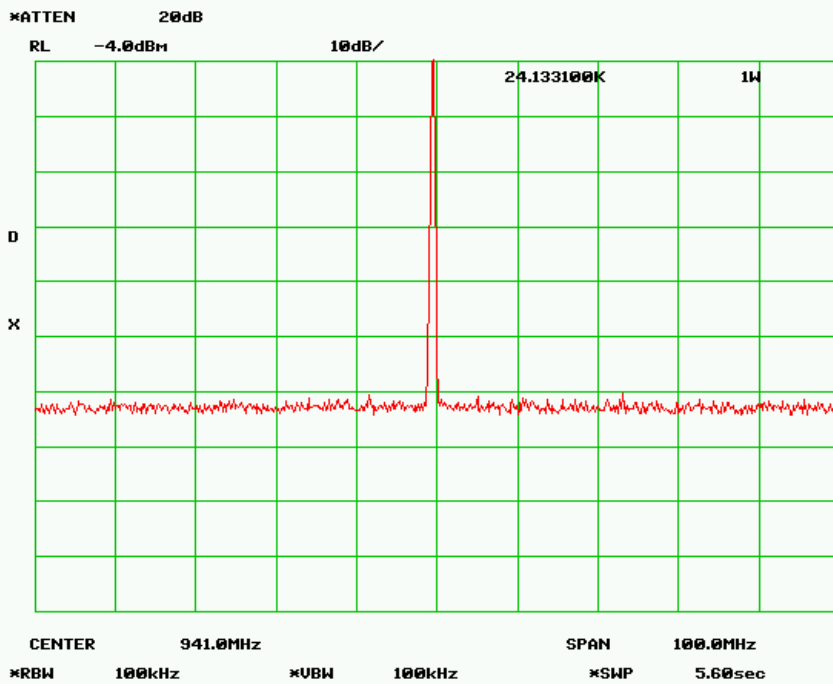
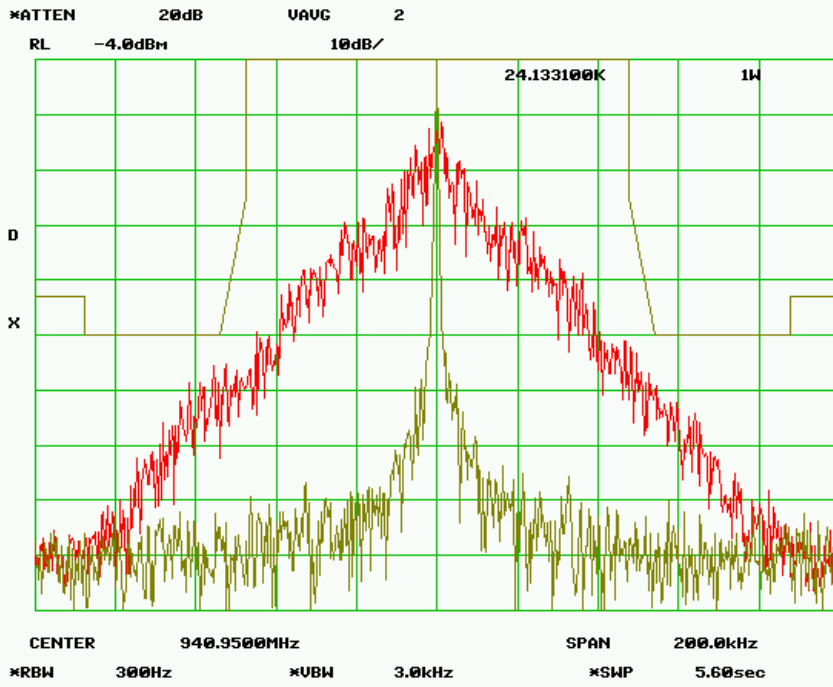

MASK 24.133a1 100 kHz - 10 Watts
RF Frequency 940.950 MHz
SPECTRUM FOR EMISSION - 49K7F1D
 Data Rate = 192kbps
 PEAK DEVIATION = 13.02 kHz

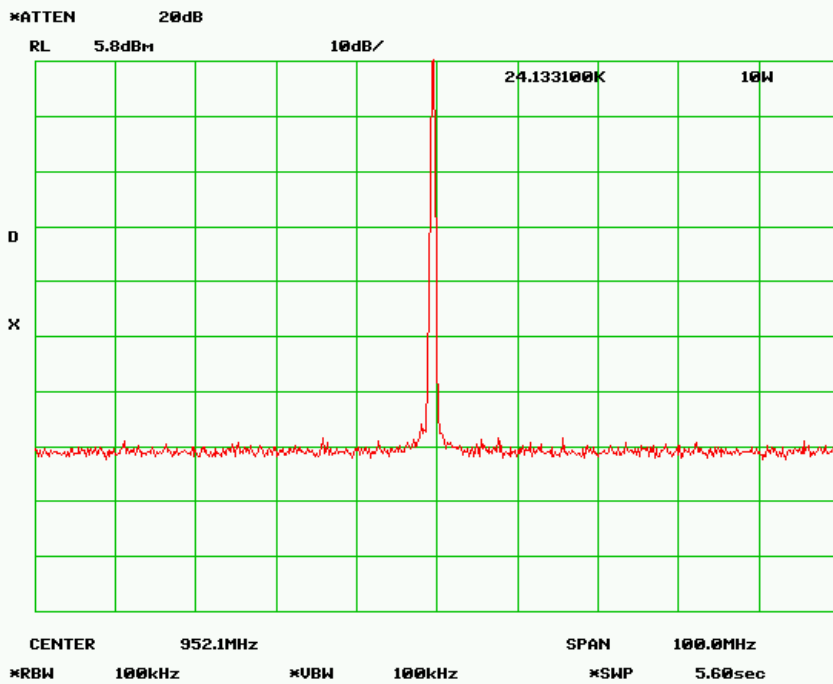
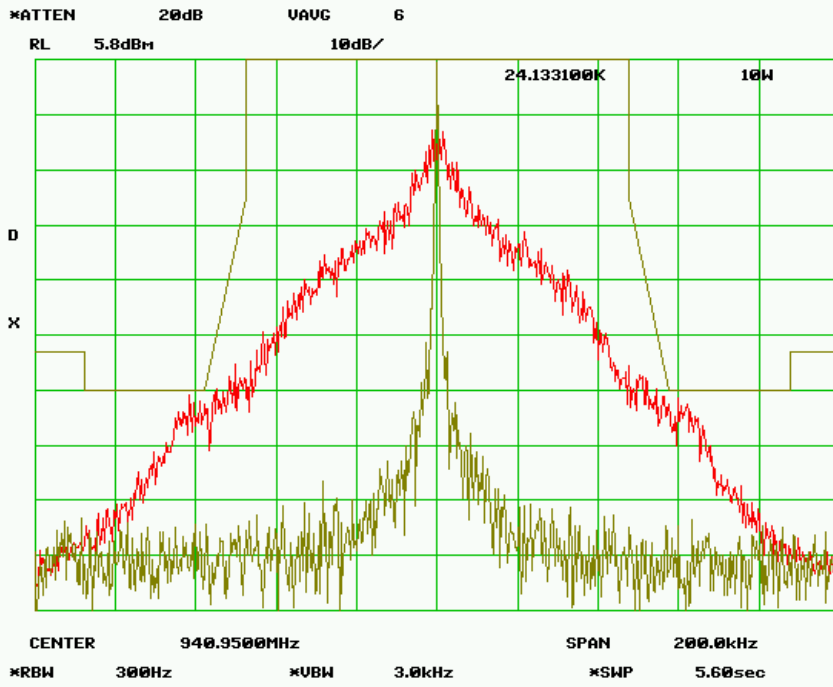

MASK 24.133a1 100 kHz - 1.0 Watt
RF Frequency 940.950 MHz
SPECTRUM FOR EMISSION - 51K3F1D
Data Rate = 256kbps
PEAK DEVIATION = 13.77 kHz

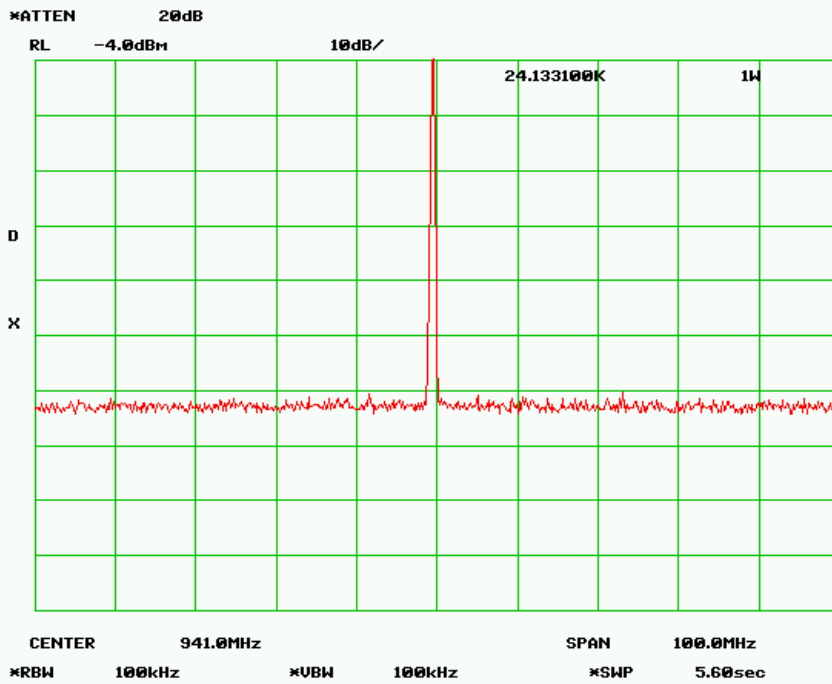
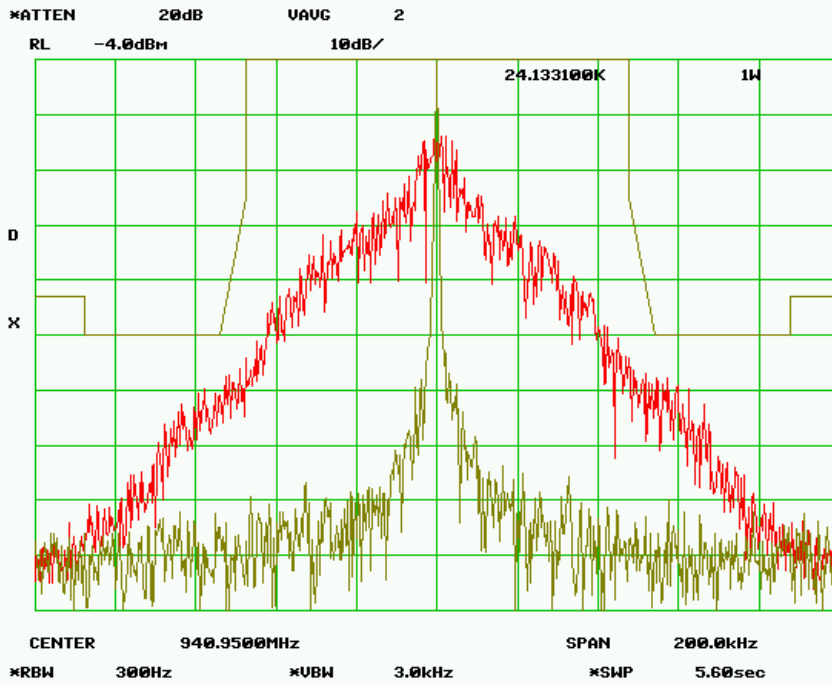

MASK 24.133a1 100 kHz - 10 Watts
RF Frequency 940.950 MHz
SPECTRUM FOR EMISSION - 51K3F1D
Data Rate = 256kbps
PEAK DEVIATION = 13.77 kHz

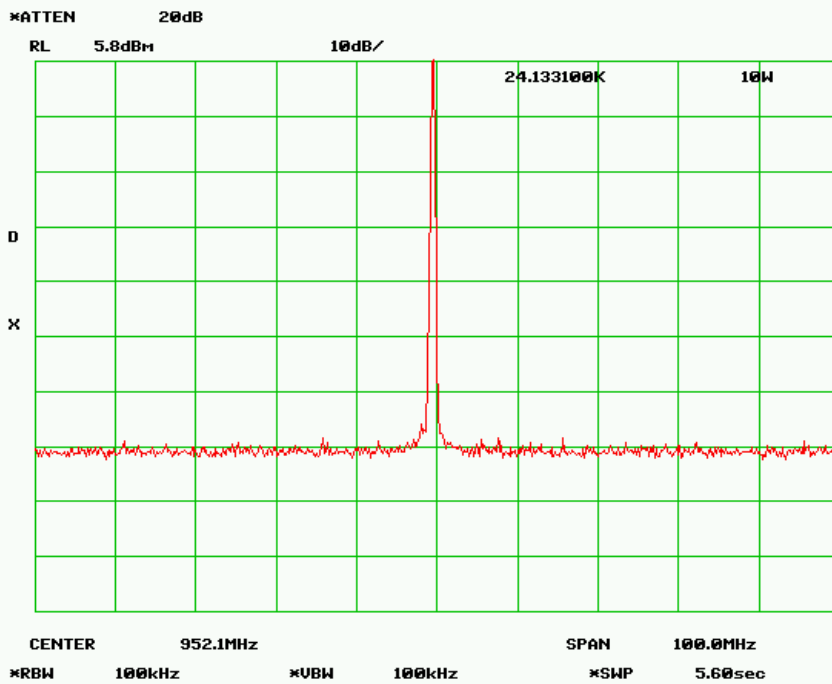
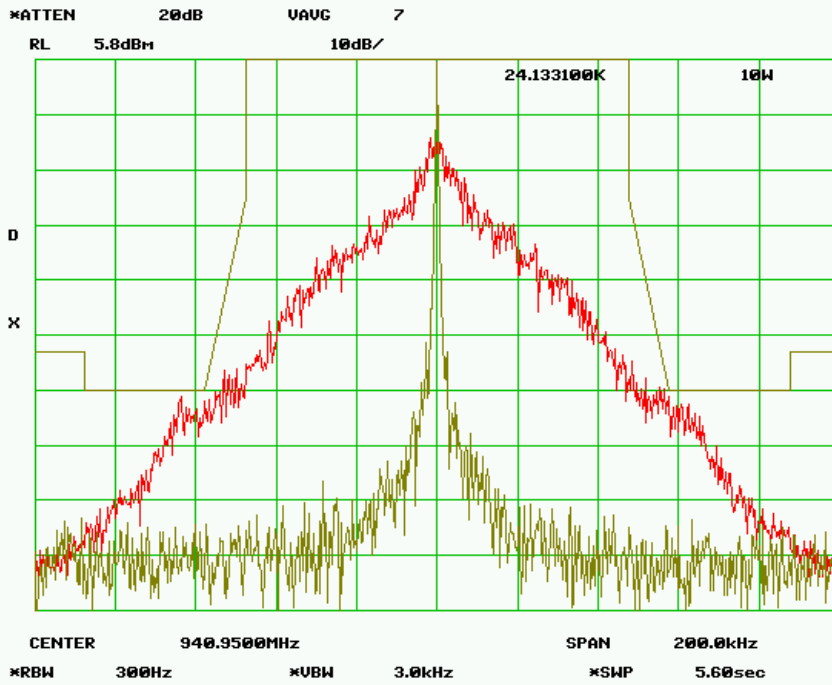

18.0 Part 101.111(a)(5) – 12.5 kHz ABW

NAME OF TEST: Transmitter Occupied Bandwidth for Emission Designators
8K20F1D, 8K30F1D, 8K50F1D and 8K08F1D

RULE PART NUMBER: FCC: 2.202, 2.1049 (c) (1), 101.111 (a)(5)

MINIMUM STANDARDS: **Mask 101.111(a)(5)**
 Sidebands and Spurious [P = 10 Watts and P=1 Watt]
 Authorized Bandwidth = 12.5 kHz
 From Fo to 2.5 kHz, down 0 dB.
 Greater than 2.5 kHz to 6.25 kHz, down 53log(fd/2.5)
 Greater than 6.25 kHz to 9.5 KHz, down 103log(fd/3.9)
 Greater than 9.5 to 15 KHz, 157log(fd/5.3)
 Greater than 15 KHz,, 50+10log(P) or 70 dB

Attenuation = 0 db from Fo to 2.50 kHz
 Attenuation = 21.1dB at 6.25 kHz
 Attenuation = 39.8 dB at 9.5 KHz
 Attenuation = 70.9 dB at 15 kHz
 Attenuation = 60 dB at > 15 KHz @ 10W
 Attenuation = 50 dB at > 15 KHz @ 1W

TEST RESULTS: Meets minimum standards (see data on following page)

TEST CONDITIONS: Standard Test Conditions, 25 C

TEST EQUIPMENT: 50-Ohm Attenuator, Bird Electronics 50-A-FFN-20 (20dB, 50W)
 50-Ohm Attenuator, Bird Electronics 10-A-MFN-10 (10dB, 10W)
 50-Ohm Attenuator, Pasternack PE7002-10 (10dB)
 Power Supply, Instek Model GPS-2303
 Spectrum Analyzer, Hewlett Packard Model HP8563E
 Modulation Analyzer, Hewlett Packard Model HP8901A

TEST SET-UP:

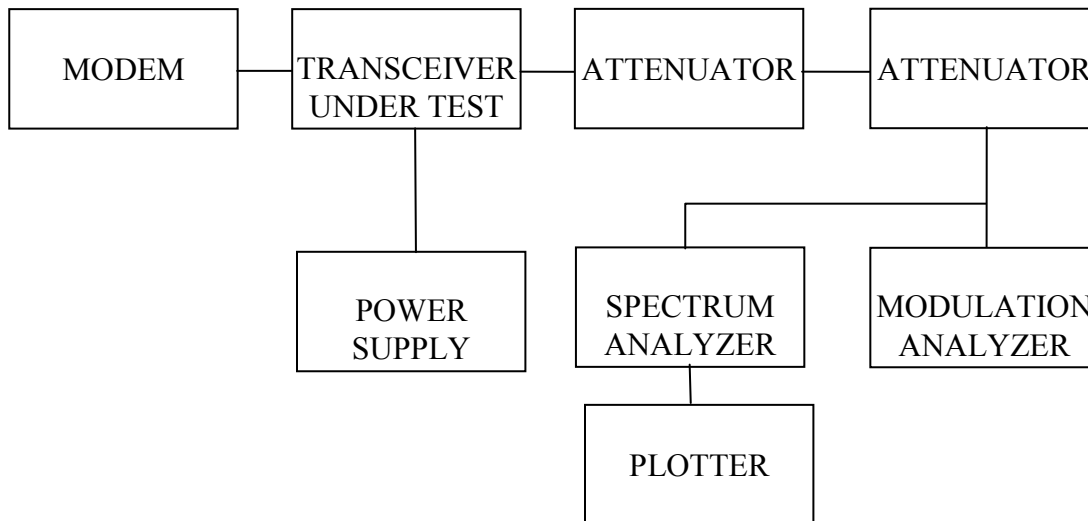

MASK 101.111a5 – 1.0 Watts
RF Frequency 952.050 MHz
SPECTRUM FOR EMISSION - 8K20F1D
 Data Rate = 8 kbps
 PEAK DEVIATION = 3.05 kHz

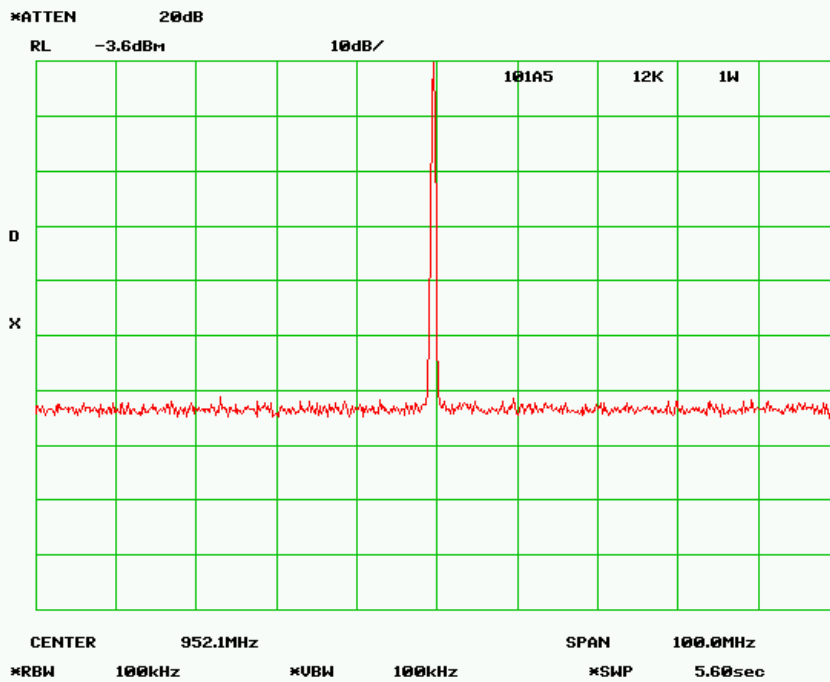
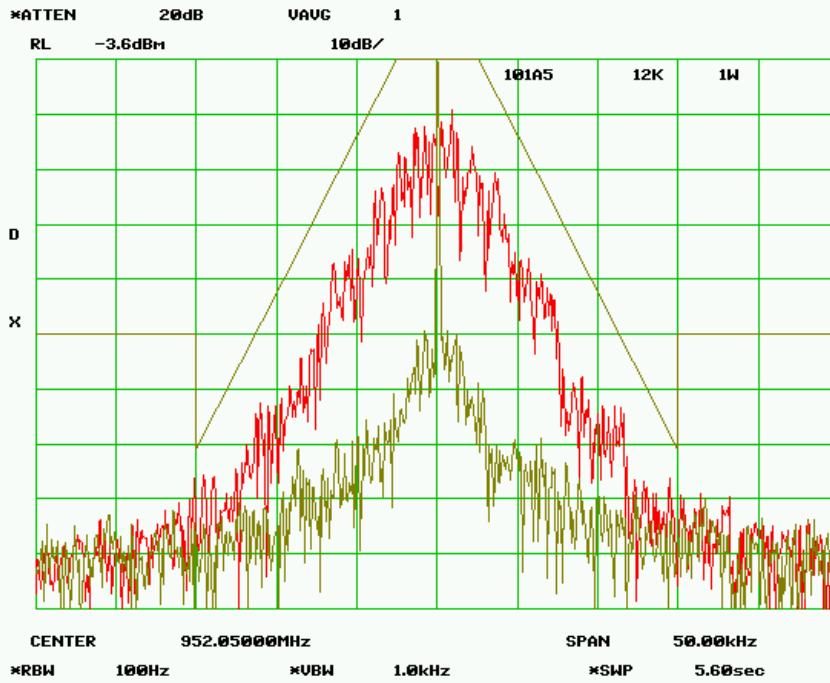

MASK 101.111a5 – 10.0 Watts
RF Frequency 952.050 MHz
SPECTRUM FOR EMISSION - 8K20F1D
Data Rate = 8 kbps
PEAK DEVIATION = 3.05 kHz

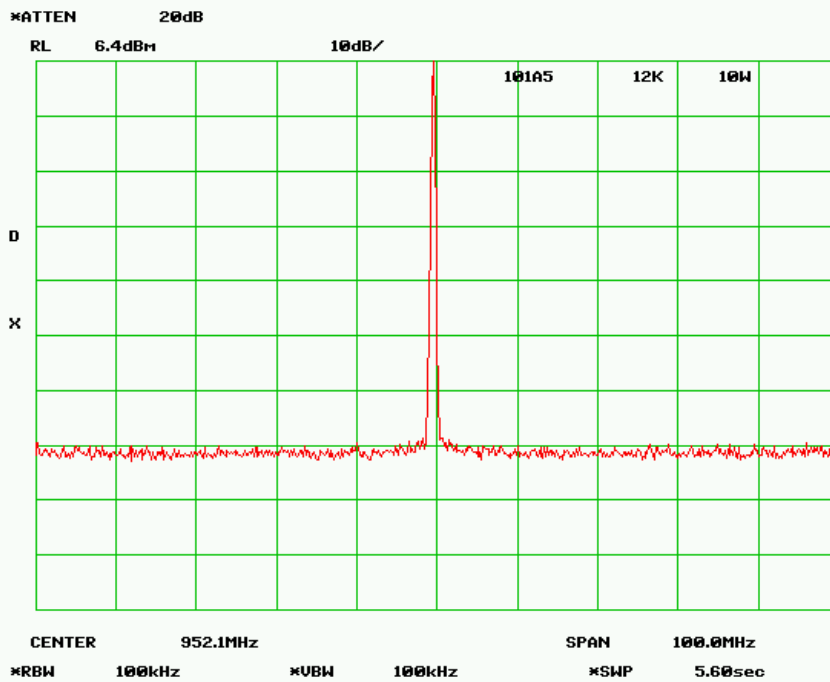
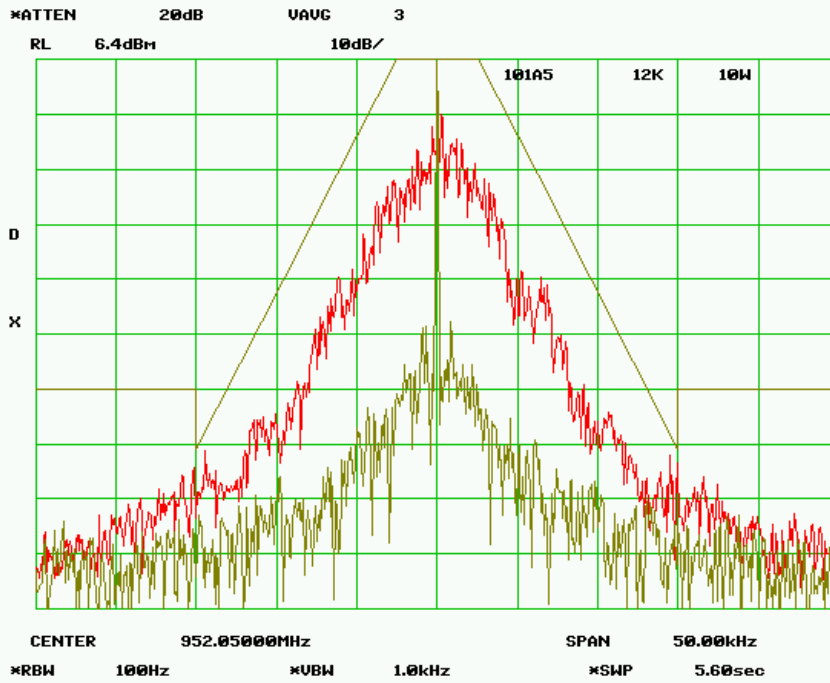

MASK 101.111a5 – 1.0 Watts
RF Frequency 952.050 MHz
SPECTRUM FOR EMISSION - 8K30F1D
Data Rate = 16 kbps
PEAK DEVIATION = 3.70 kHz

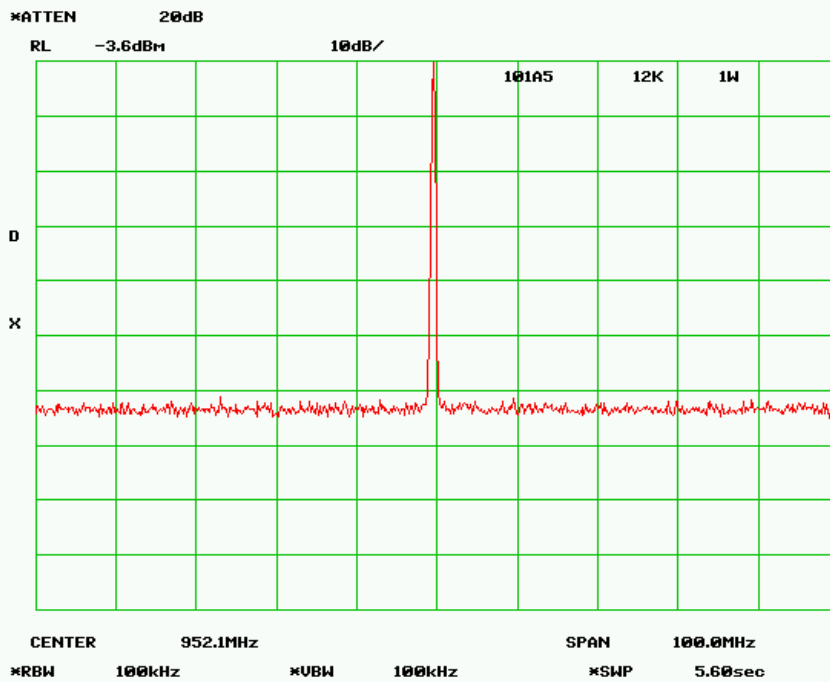
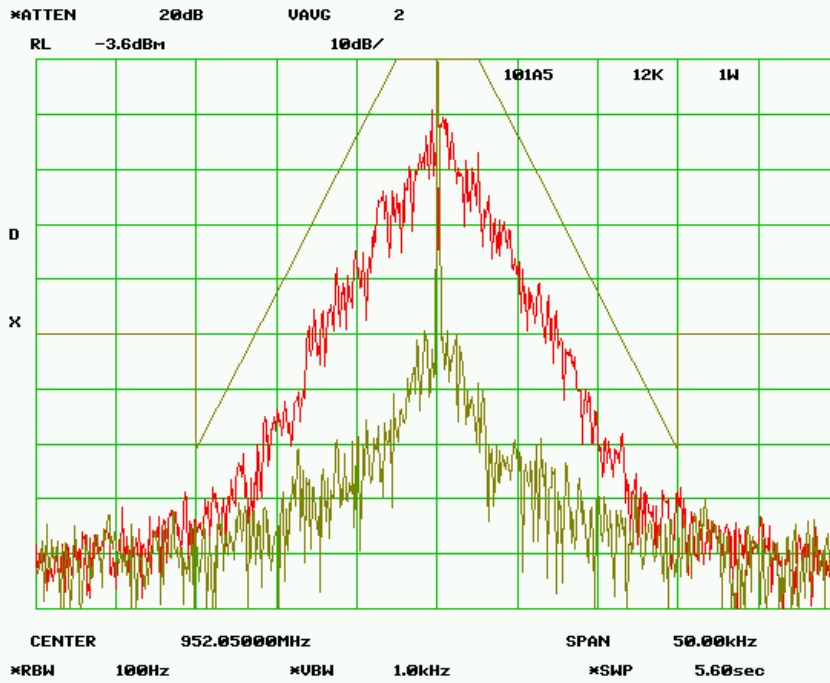

MASK 101.111a5 – 10.0 Watts
RF Frequency 952.050 MHz
SPECTRUM FOR EMISSION - 8K30F1D
Data Rate = 16 kbps
PEAK DEVIATION = 3.70 kHz

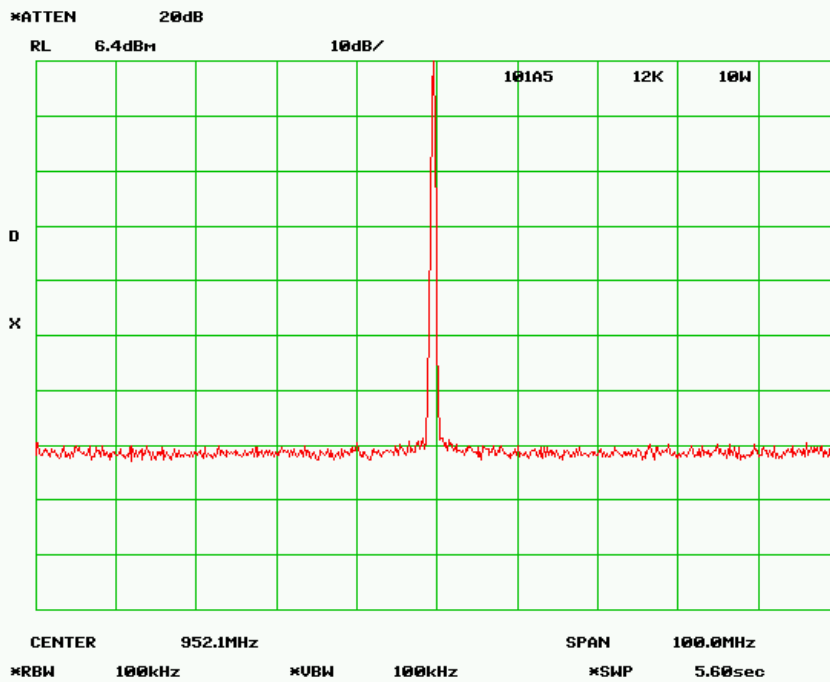
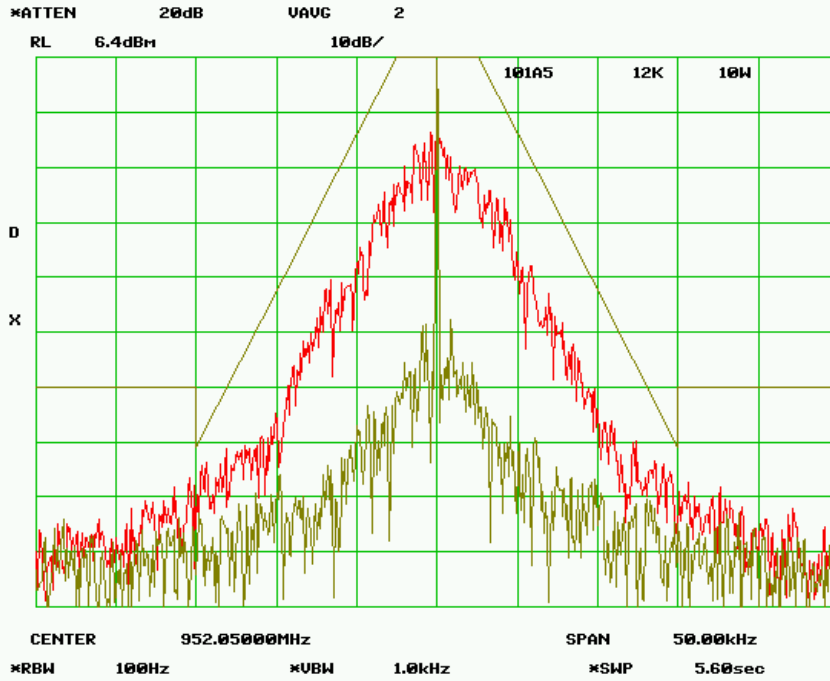

MASK 101.111a5 – 1.0 Watts
RF Frequency 952.050 MHz
SPECTRUM FOR EMISSION - 8K50F1D
Data Rate = 24 kbps
PEAK DEVIATION = 3.725 kHz

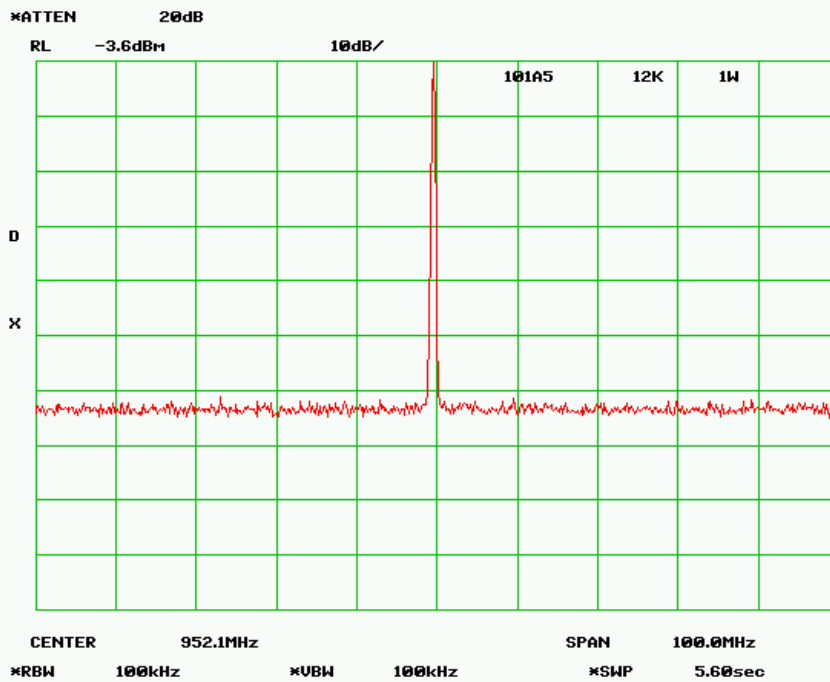
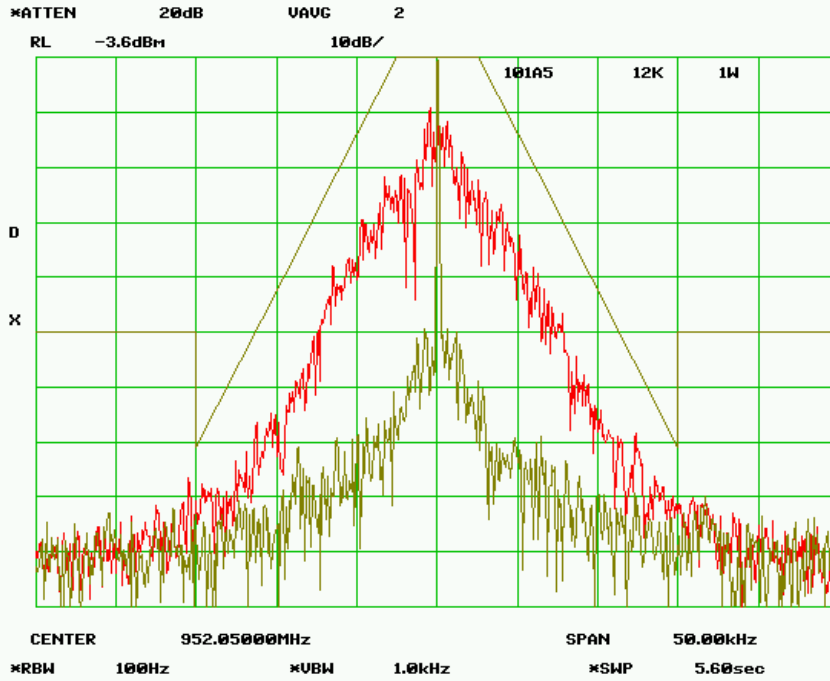

MASK 101.111a5 – 10.0 Watts
RF Frequency 952.050 MHz
SPECTRUM FOR EMISSION - 8K50F1D
Data Rate = 24 kbps
PEAK DEVIATION = 3.725 kHz

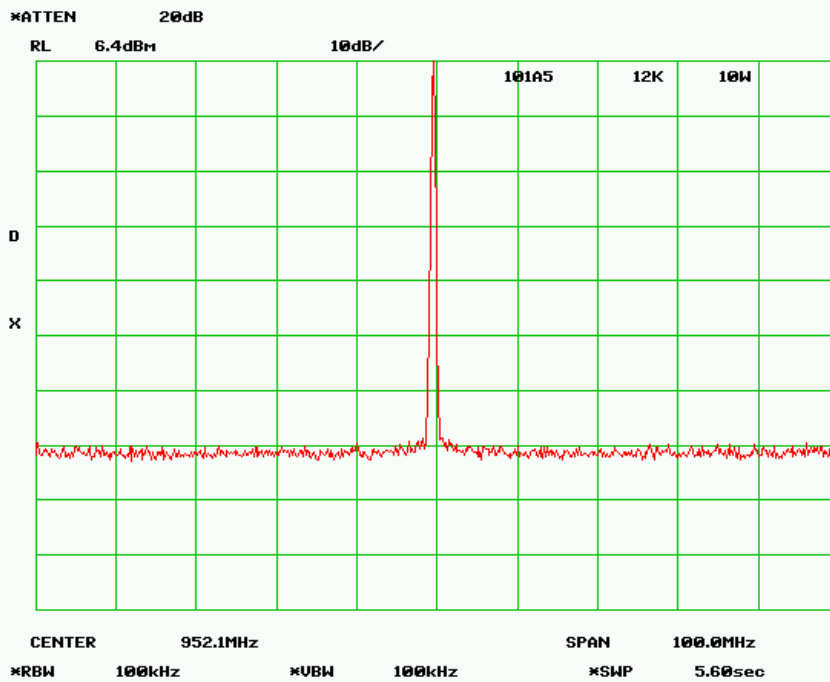
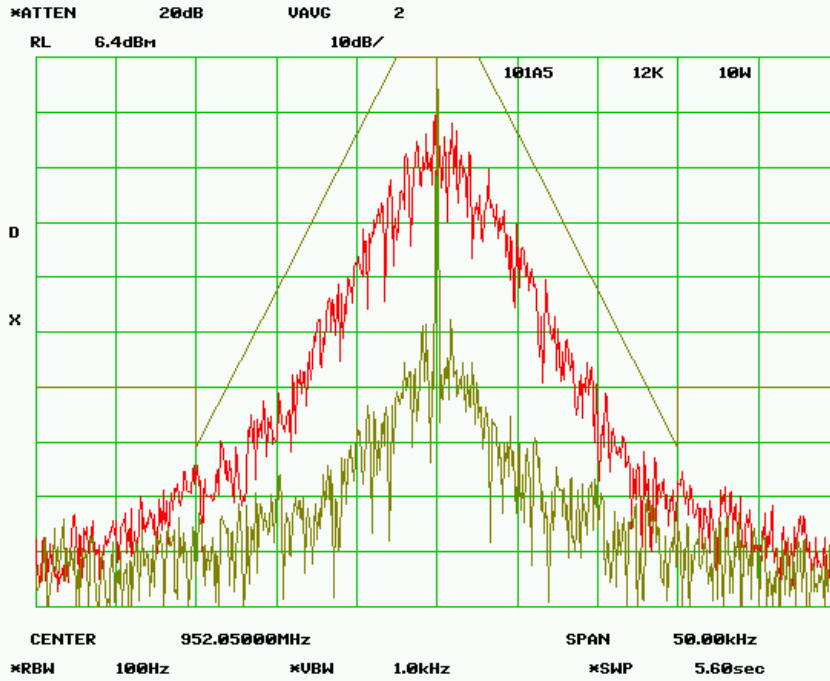

MASK 101.111a5 – 1.0 Watts
RF Frequency 952.050 MHz
SPECTRUM FOR EMISSION - 8K08F1D
Data Rate = 32 kbps
PEAK DEVIATION = 3.728 kHz

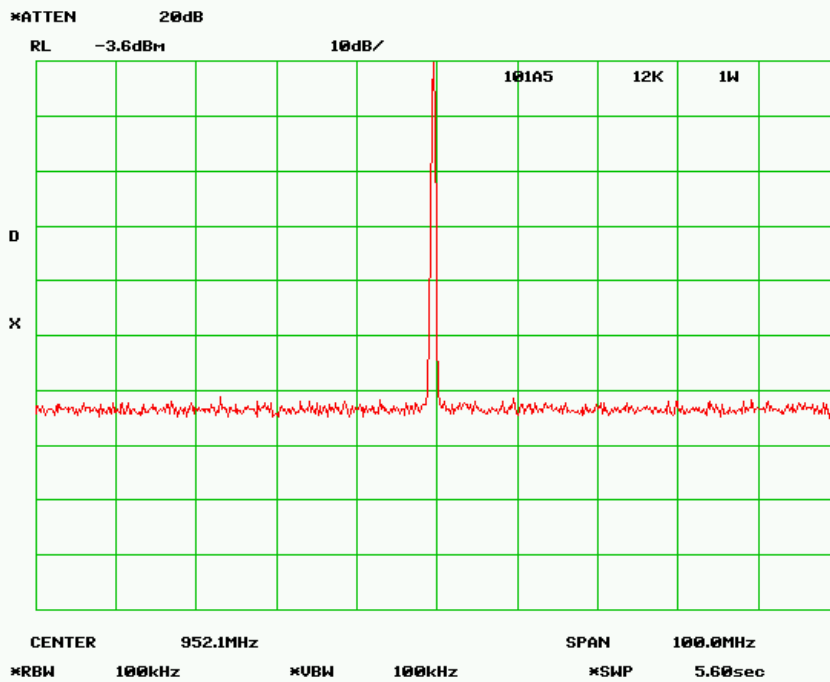
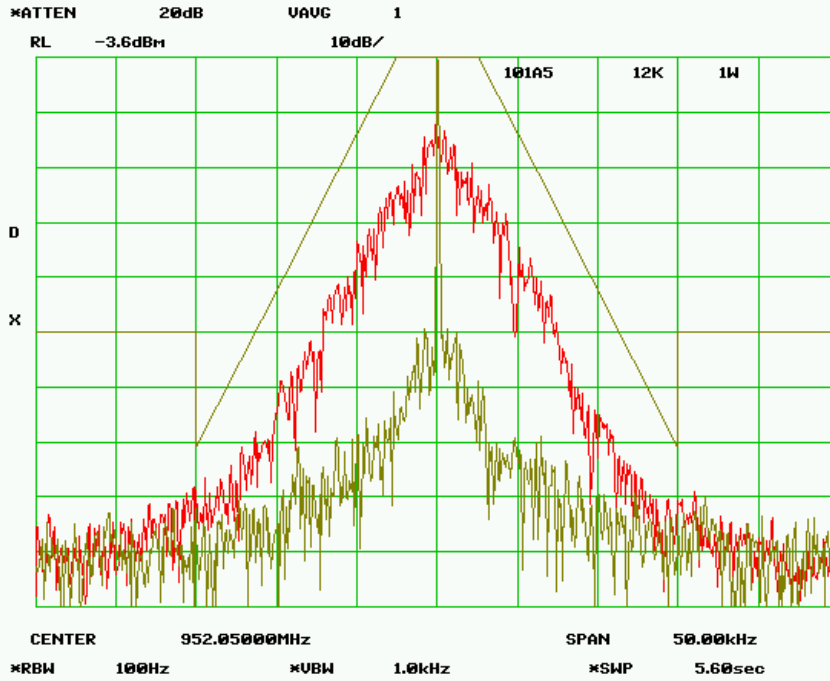

MASK 101.111a5 – 10.0 Watts
RF Frequency 952.050 MHz
SPECTRUM FOR EMISSION - 8K08F1D
Data Rate = 32 kbps
PEAK DEVIATION = 3.728 kHz

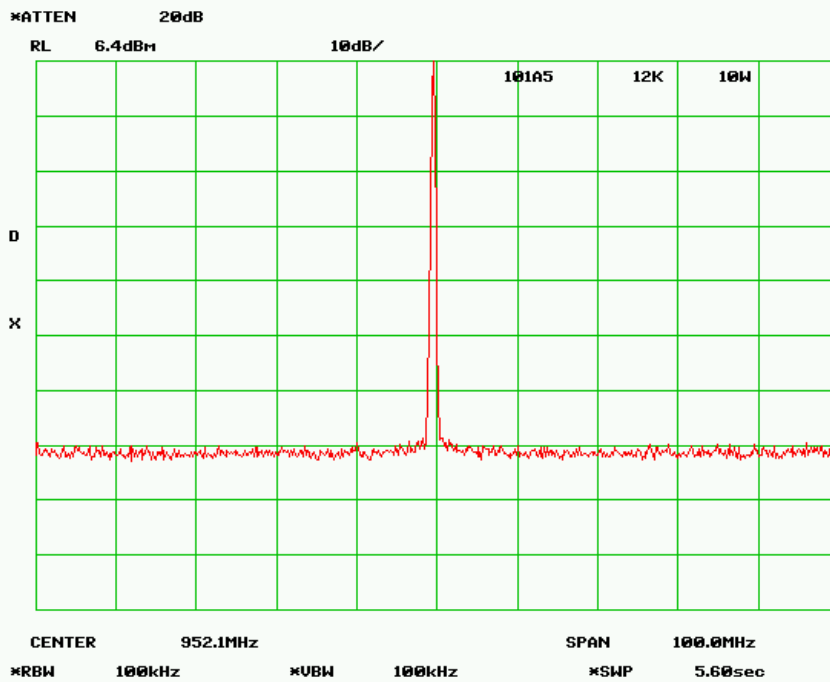
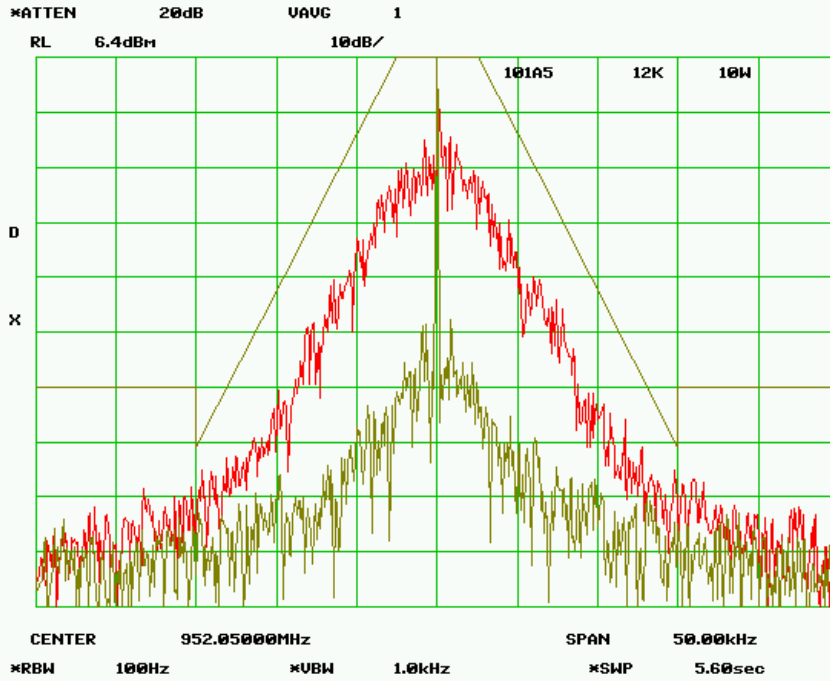

19.0 Part 101.111(a)(6) – 25 kHz ABW

NAME OF TEST: Transmitter Occupied Bandwidth for Emission Designators **16K5F1D**, **16K8F1D**, **17K8F1D**, and **17K0F1D**

RULE PART NUMBER: FCC: 2.202, 2.1049 (c) (1), 101.109, 101.111 (a)(5)

MINIMUM STANDARDS: **Mask 101.111(a)(6)**
 Sidebands and Spurious [P = 10 Watts and P=1 Watt]
 Authorized Bandwidth = 25 kHz
 From Fo to 5.0 kHz, down 0 dB.
 From 5 kHz to 10 kHz, down $83 * \log_{10}(f_d / 5)$ dB
 Greater than 10.0 kHz to 250% auth BW, down $116\log(fd/6.1)$ or $50+10\log(P)$ or 70 dB.
 Greater than 250% auth BW, $43+10\log_{10}(P)$ or 80 dB.

Attenuation = 0 db at Fo to 5 kHz
 Attenuation = 25 dB at 10 kHz
 Attenuation = 60 dB at 20.1 kHz @ 10W
 Attenuation = 50 dB at 16.5 kHz @ 1W
 Attenuation = 53 dB at > 62.5 kHz @ 10W
 Attenuation = 43 dB at > 62.5 kHz @ 1W

TEST RESULTS: Meets minimum standards (see data on following page)

TEST CONDITIONS: Standard Test Conditions, 25 C
 RF Power Level = 1 Watt and 10 Watts
 Voltage = 20VDC

TEST PROCEDURE: TIA/EIA – 603-C

TEST EQUIPMENT: 50-Ohm Attenuator, Bird Electronics 50-A-FFN-20 (20dB, 50W)
 50-Ohm Attenuator, Bird Electronics 10-A-MFN-10 (10dB, 10W)
 50-Ohm Attenuator, Pasternack PE7002-10 (10dB)
 Power Supply, Instek Model GPS-2303
 Spectrum Analyzer, Hewlett Packard Model HP8563E
 Modulation Analyzer, Hewlett Packard Model HP8901A

TEST SET-UP:

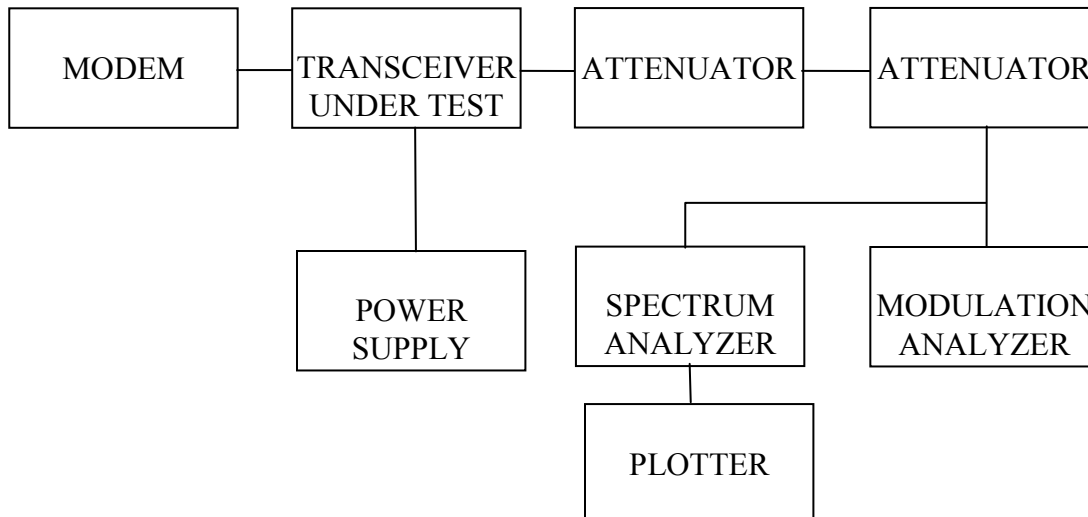

MASK 101.111a6 - 1.0 Watt
RF Frequency 952.050 MHz
SPECTRUM FOR EMISSION - 16K5F1D
 Data Rate =16 kbps
 PEAK DEVIATION = 6.30 kHz

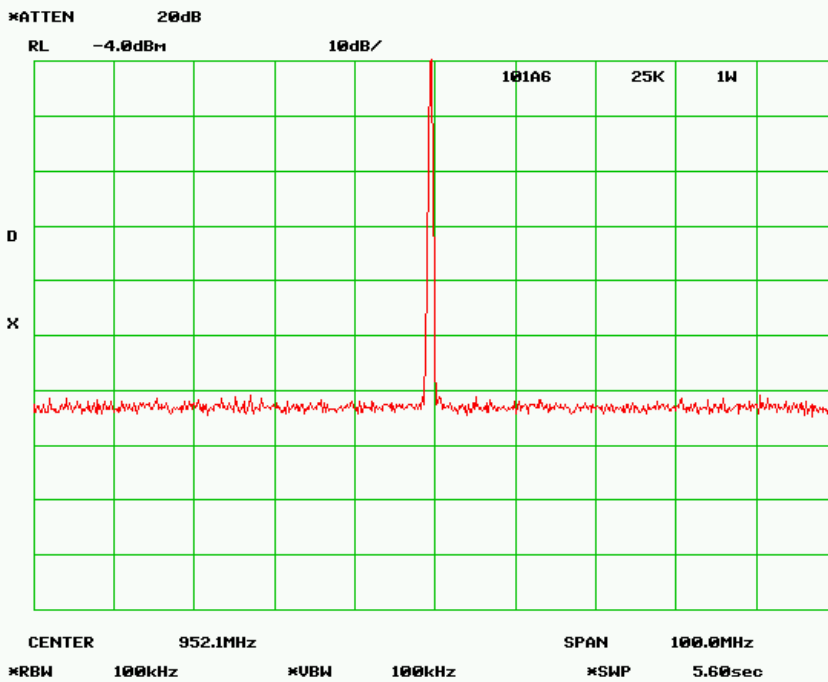
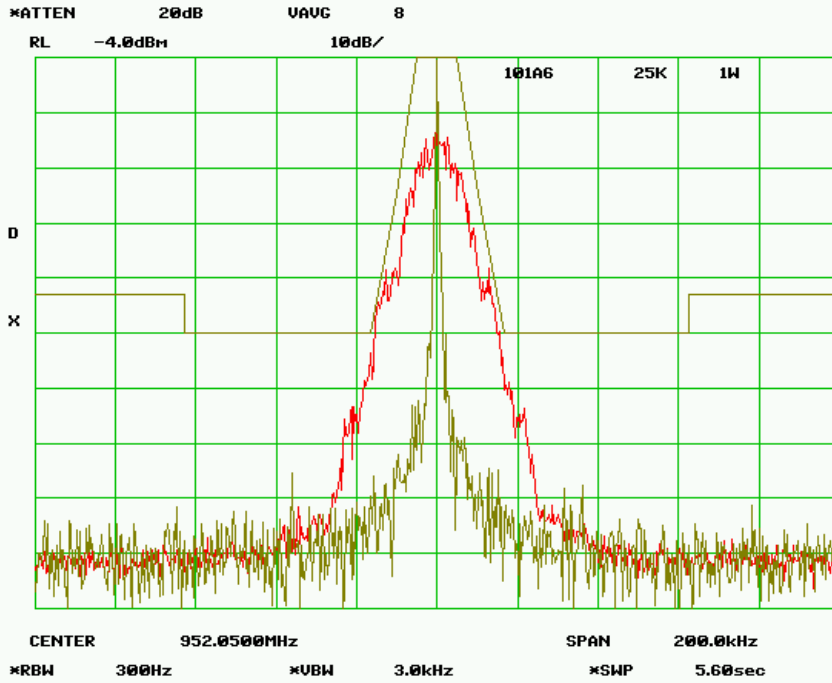

MASK 101.111a6 - 10.0 Watt
RF Frequency 952.050 MHz
SPECTRUM FOR EMISSION - 16K5F1D
Data Rate = 16 kbps
PEAK DEVIATION = 6.30 kHz

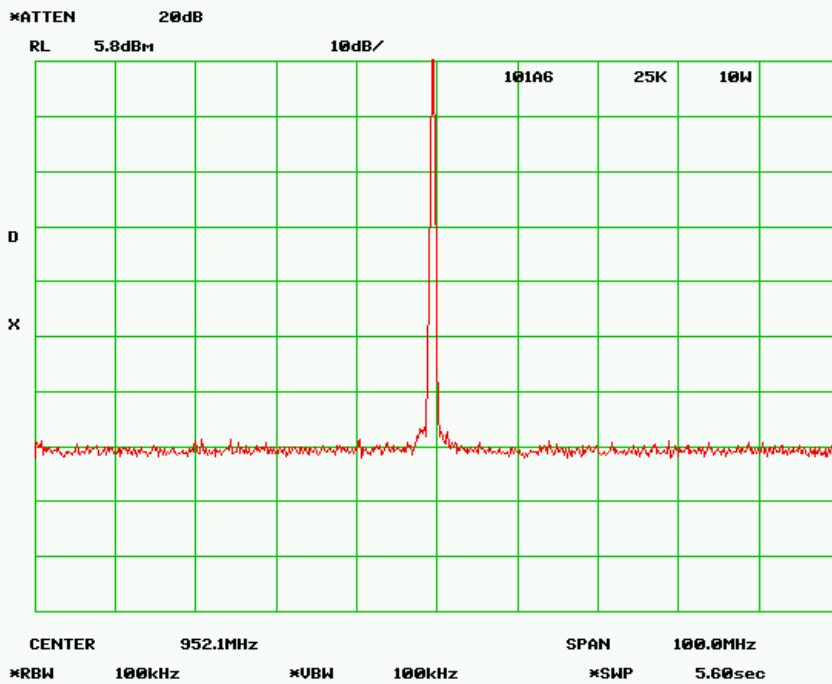
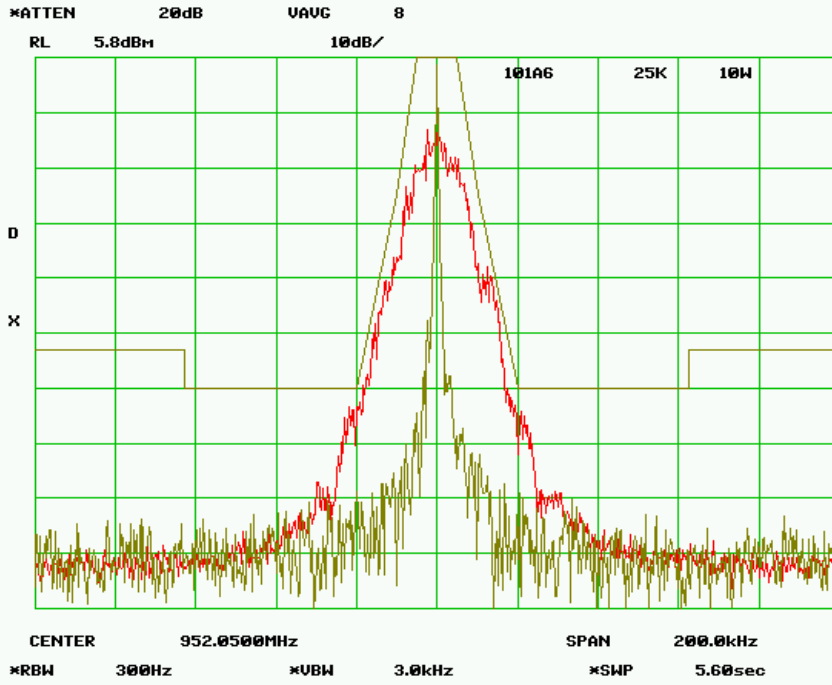

MASK 101.111a6 - 1.0 Watt
RF Frequency 952.050 MHz
SPECTRUM FOR EMISSION - 16K8F1D
Data Rate = 32 kbps
PEAK DEVIATION = 6.30 kHz

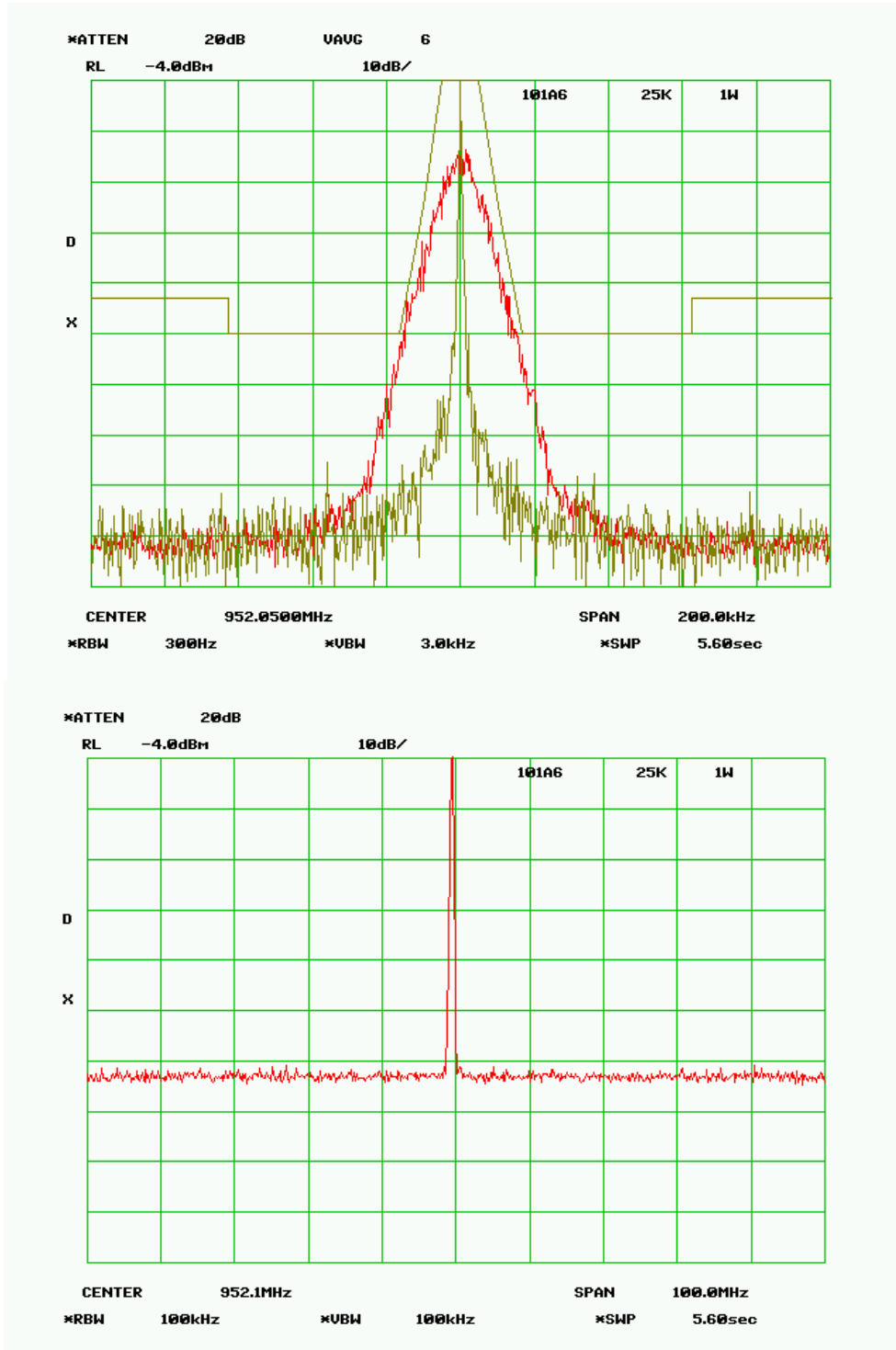

MASK 101.111a6 - 10 Watts
RF Frequency 952.050 MHz
SPECTRUM FOR EMISSION - 16K8F1D
Data Rate = 32 kbps
PEAK DEVIATION = 6.30 kHz

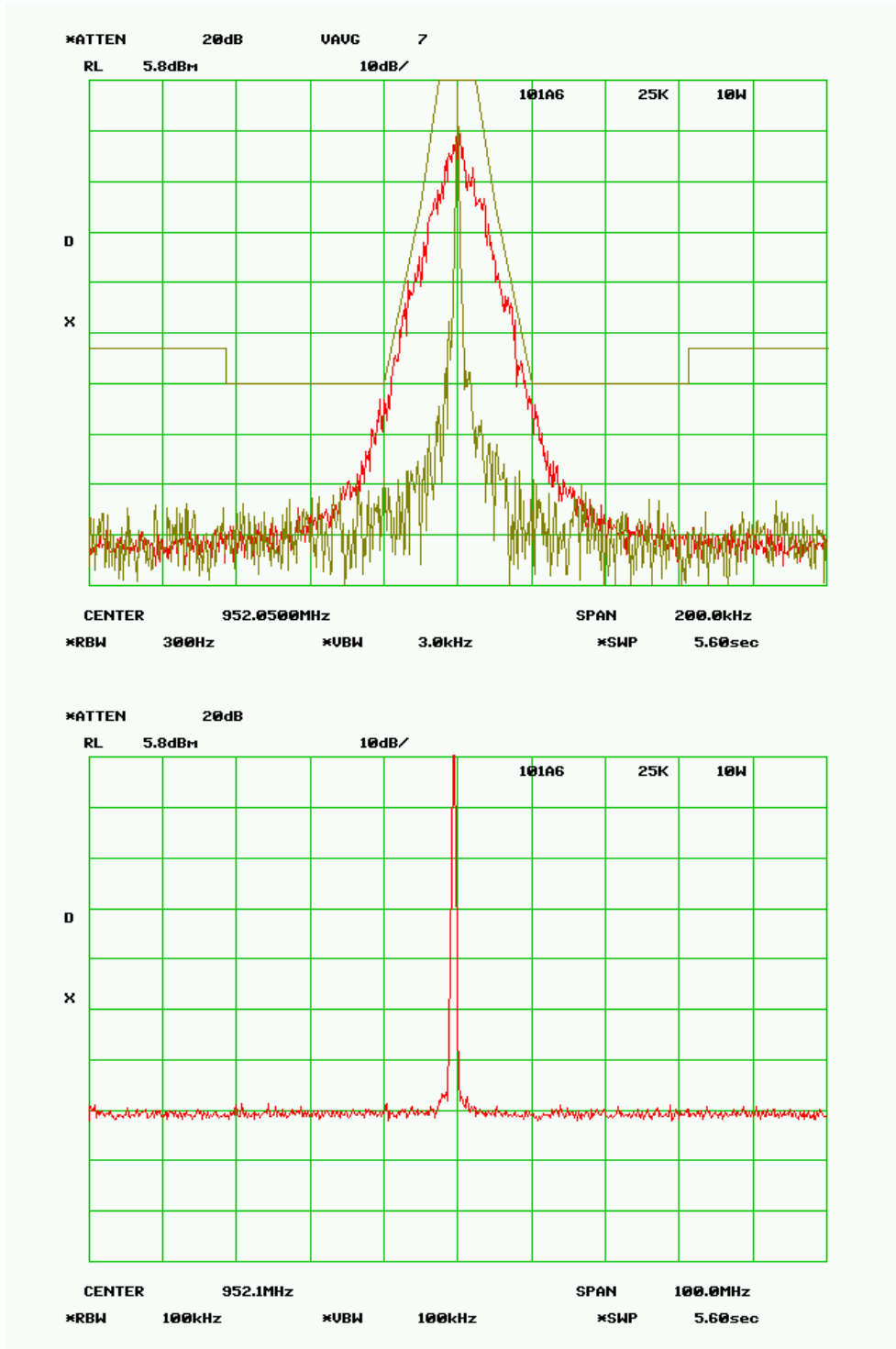

MASK 101.111a6 - 1.0 Watt
RF Frequency 952.050 MHz
SPECTRUM FOR EMISSION - 17K8F1D
Data Rate = 48 kbps
PEAK DEVIATION = 7.59 kHz

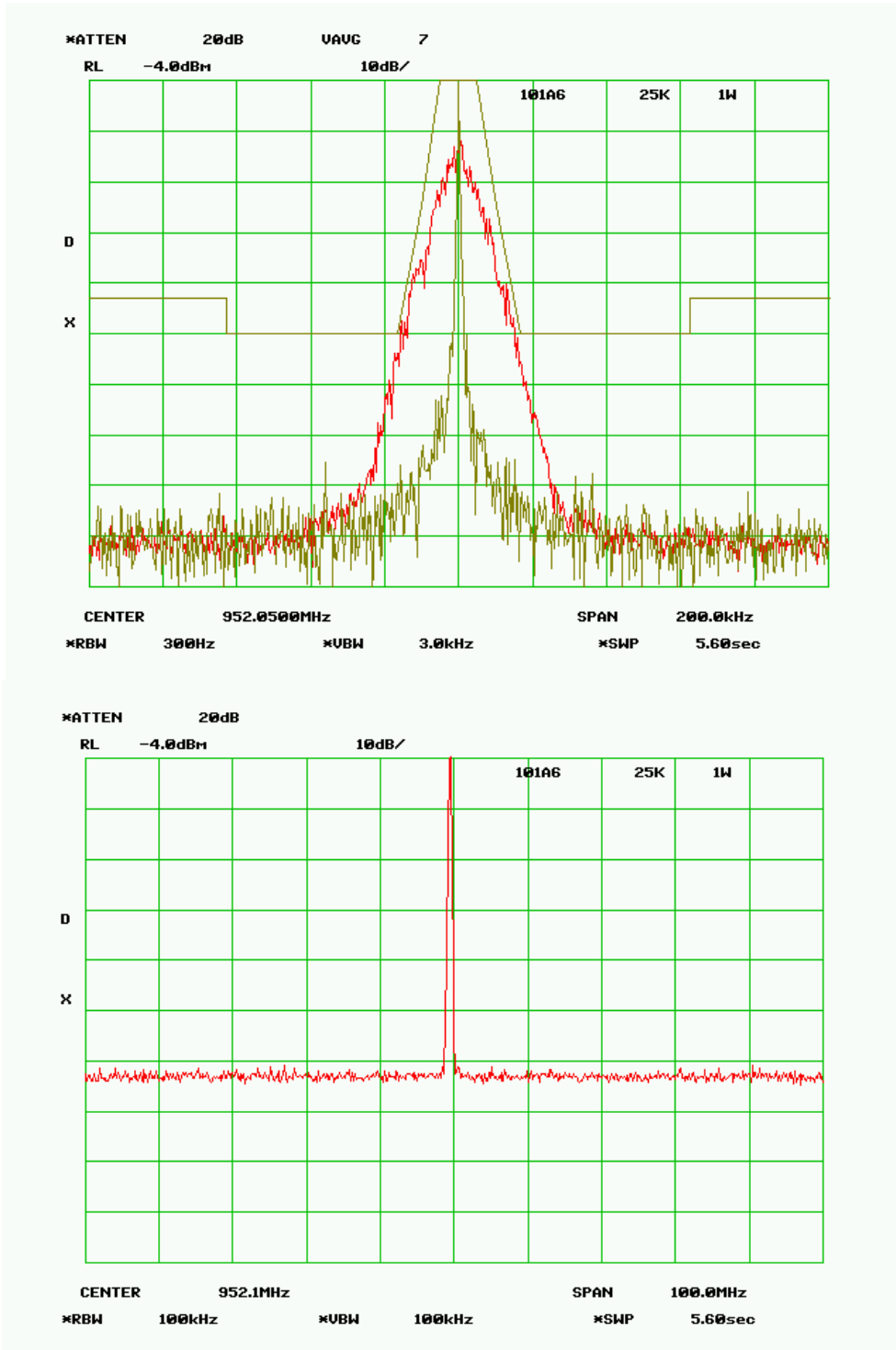

MASK 101.111a6 - 10 Watts
RF Frequency 952.050 MHz
SPECTRUM FOR EMISSION - 17K8F1D
Data Rate = 48 kbps
PEAK DEVIATION = 7.59 kHz

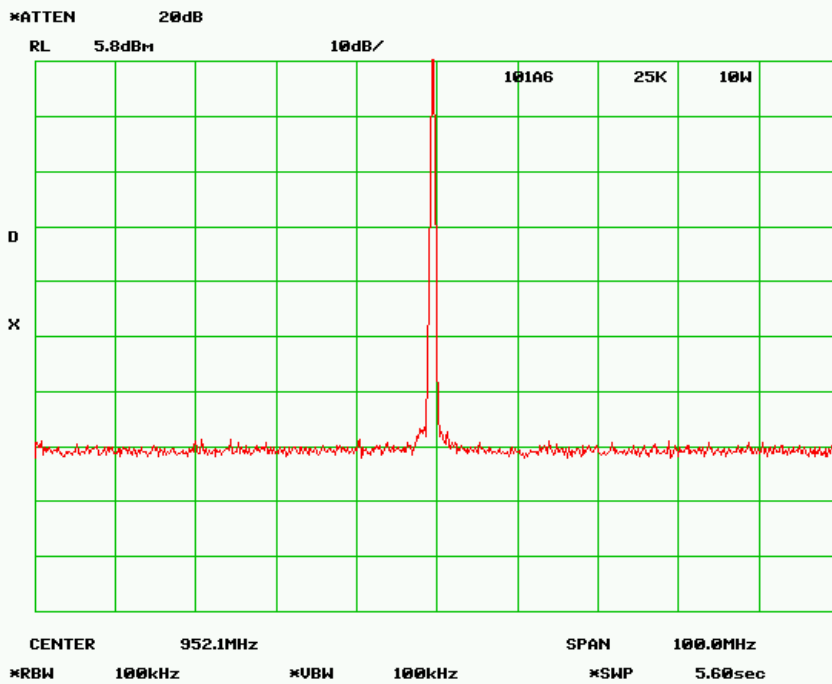
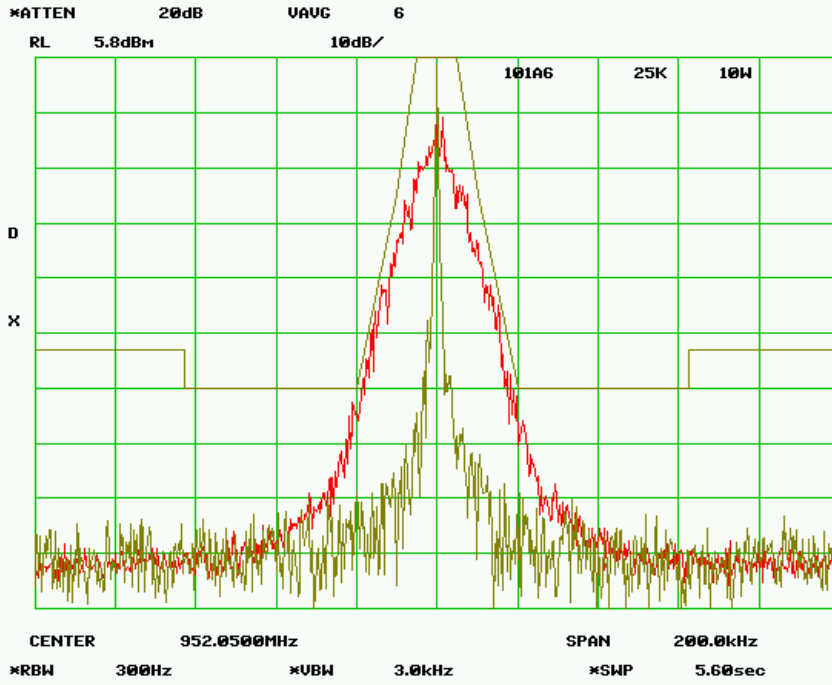

MASK 101.111a6 - 1.0 Watt
RF Frequency 952.050 MHz
SPECTRUM FOR EMISSION - 17K0F1D
Data Rate = 64kbps
PEAK DEVIATION = 7.52 kHz

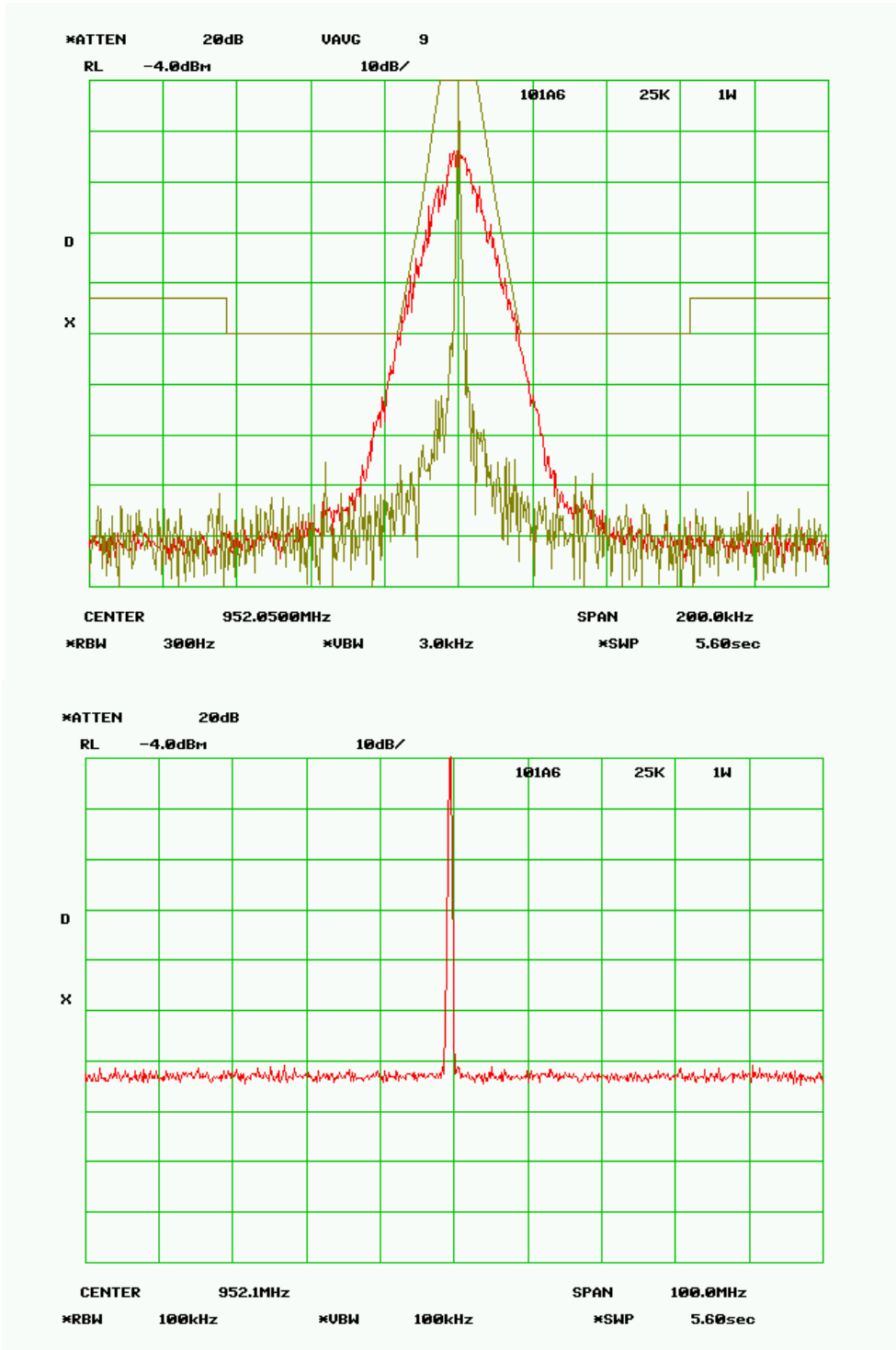

MASK 101.111a6 - 10 Watts
RF Frequency 952.050 MHz
SPECTRUM FOR EMISSION - 17K0F1D
Data Rate = 64 kbps
PEAK DEVIATION = 7.52 kHz

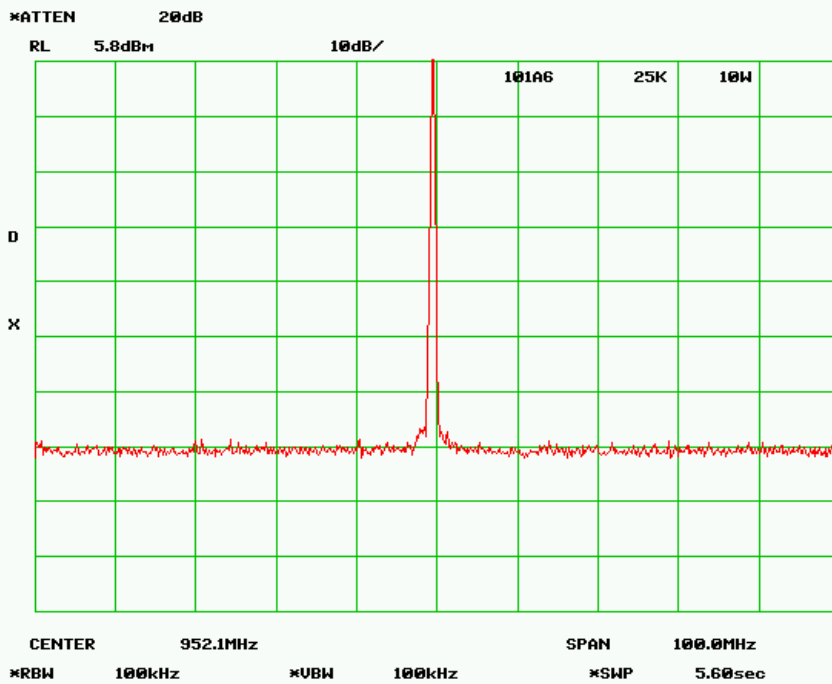
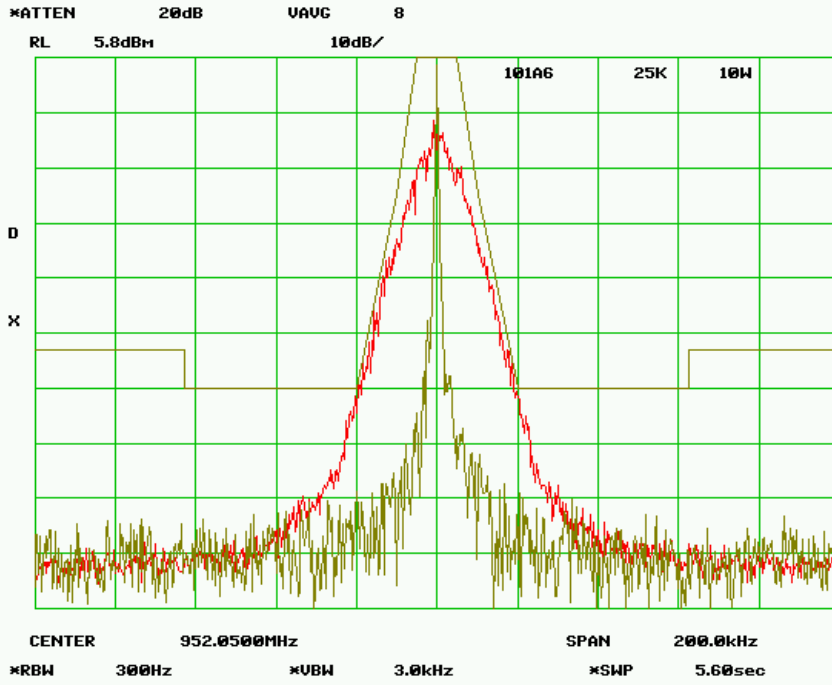

20.0 Part 101.111(a)(6) – 50 kHz ABW

NAME OF TEST: Transmitter Occupied Bandwidth for Emission Designators
29K8F1D, 30K0F1D, 29K5F1D, 30K5F1D

RULE PART NUMBER: FCC: 2.202, 2.1049 (c) (1), 101.109, 101.111 (a)(6)

MINIMUM STANDARDS: **Mask 101.111(a)(6) 50 kHz**
 Sidebands and Spurious [P = 10 Watts and P=1 Watt]
 Authorized Bandwidth = 50 kHz
 From Fo to 17.5 kHz, down 0 dB.
 From 17.5 kHz to 22.5 kHz, down $83 * \log_{10}(f_d / 5)$ dB
 Greater than 22.5 kHz to 250% auth BW, down $116\log(fd/6.1)$
 or $50+10\log(P)$ or 70 dB.
 Greater than 250% auth BW, $43+10\log_{10}(P)$ or 80 dB.

Attenuation = 0 db at Fo to 17.5 kHz
 Attenuation = 25 dB at 22.5 kHz
 Attenuation = 60 dB at 32.6 kHz @ 10W
 Attenuation = 50 dB at 29.0 kHz @ 1W
 Attenuation = 53 dB at > 75 kHz @ 10W
 Attenuation = 43 dB at > 75 kHz @ 1W

TEST RESULTS: Meets minimum standards (see data on following page)

TEST CONDITIONS: Standard Test Conditions, 25 C
 RF Power Level = 1 Watt and 12 Watts
 Voltage = 20VDC

TEST PROCEDURE: TIA/EIA – 603-C, 2.2.13, 3.2.11.2

TEST EQUIPMENT: 50-Ohm Attenuator, Bird Electronics Model 50-A-FFN-20 (20dB, 50W)
 50-Ohm Attenuator, Bird Electronics Model 10-A-MFN-10 (10dB, 10W)
 50-Ohm Attenuator, Pasternack Model PE7002-10 (10dB)
 DC Power Supply, Hewlett Packard Model 6653A
 Spectrum Analyzer, Hewlett Packard Model HP8563E
 Modulation Analyzer, Hewlett Packard Model HP8901A

TEST SET-UP:

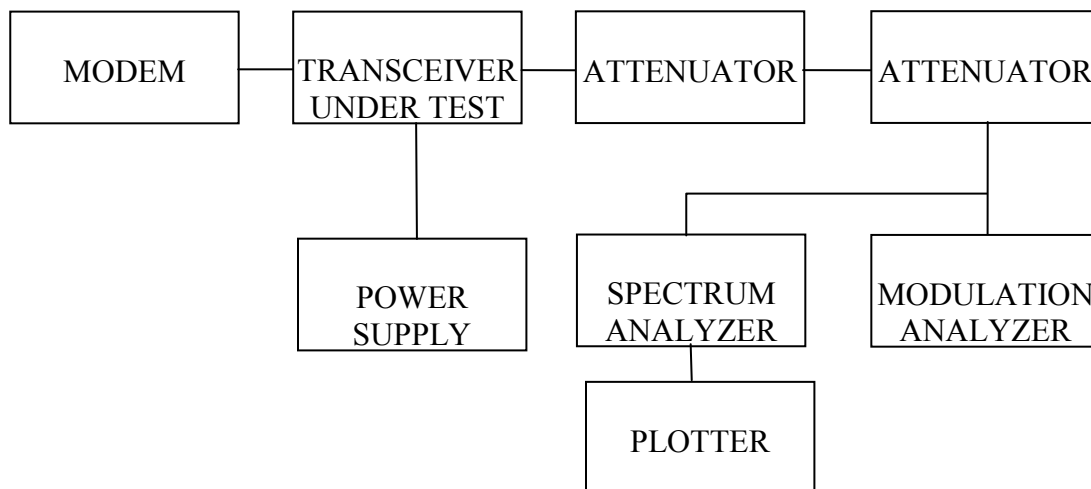

MASK 101.111a6 50 kHz- 1.0 Watt
RF Frequency 952.050 MHz
SPECTRUM FOR EMISSION - 29K8F1D
Data Rate =32 kbps
PEAK DEVIATION = 9.36 kHz

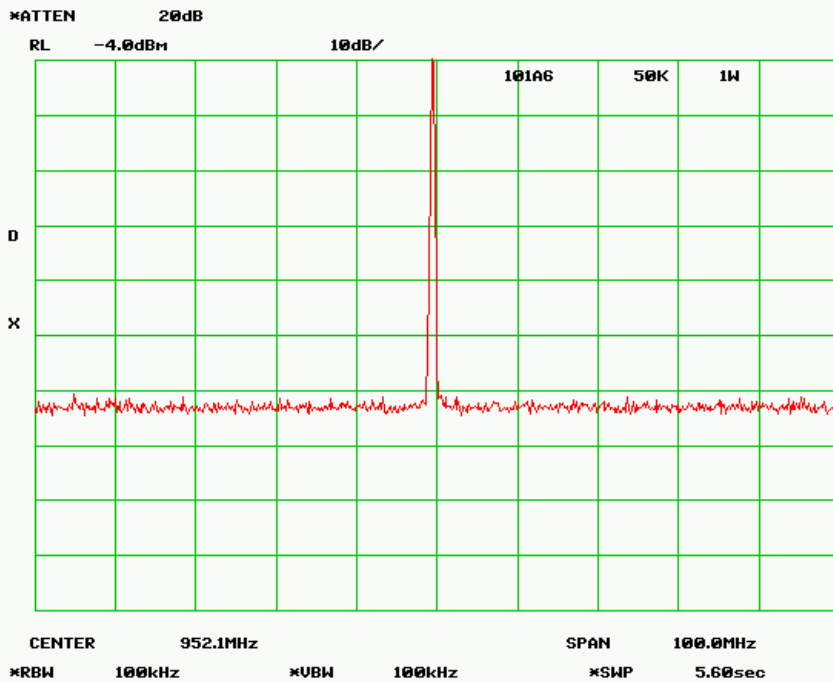
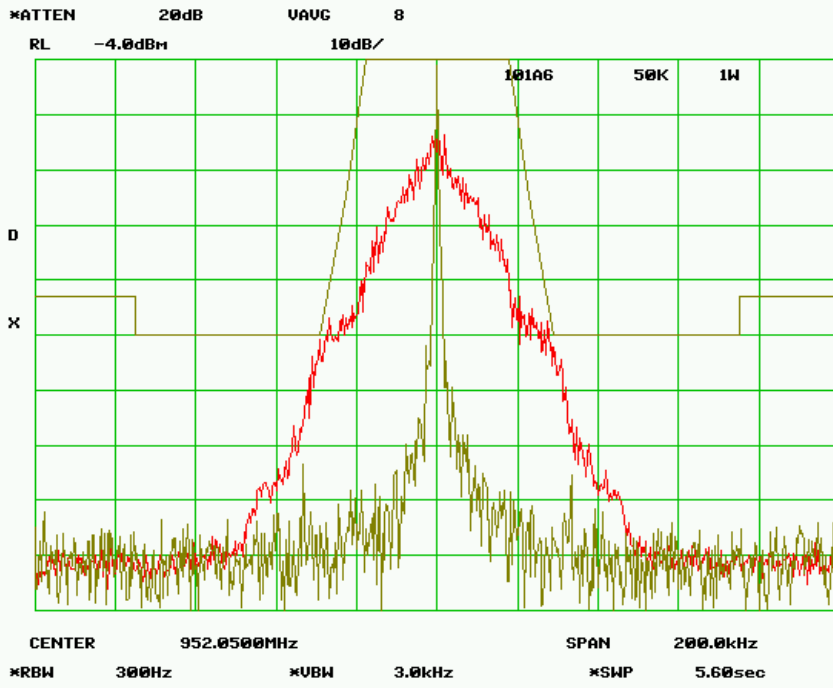

MASK 101.111a6 50 kHz- 10.0 Watt
RF Frequency 952.050 MHz
SPECTRUM FOR EMISSION - 29K8F1D
 Data Rate =32 kbps
 PEAK DEVIATION = 9.36 kHz

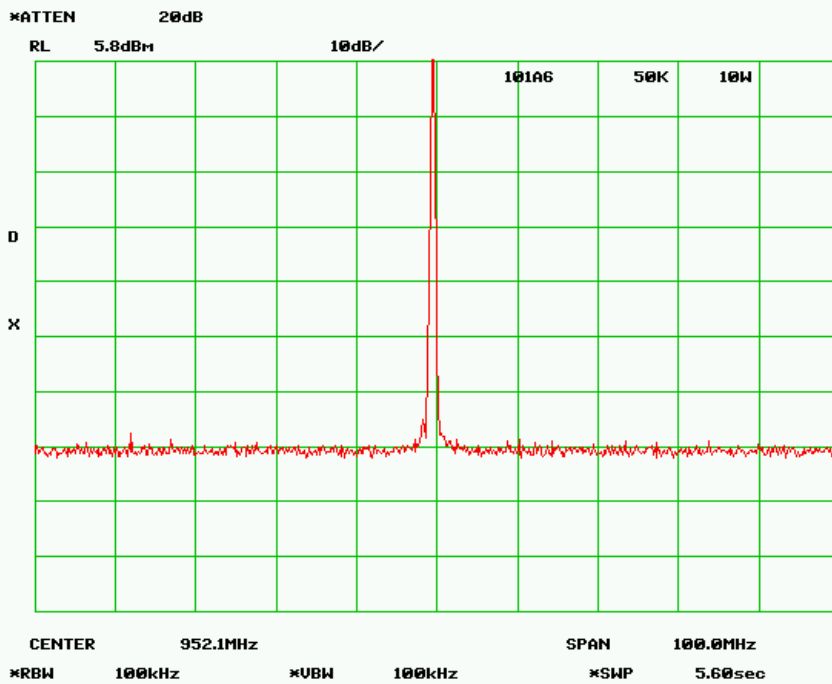
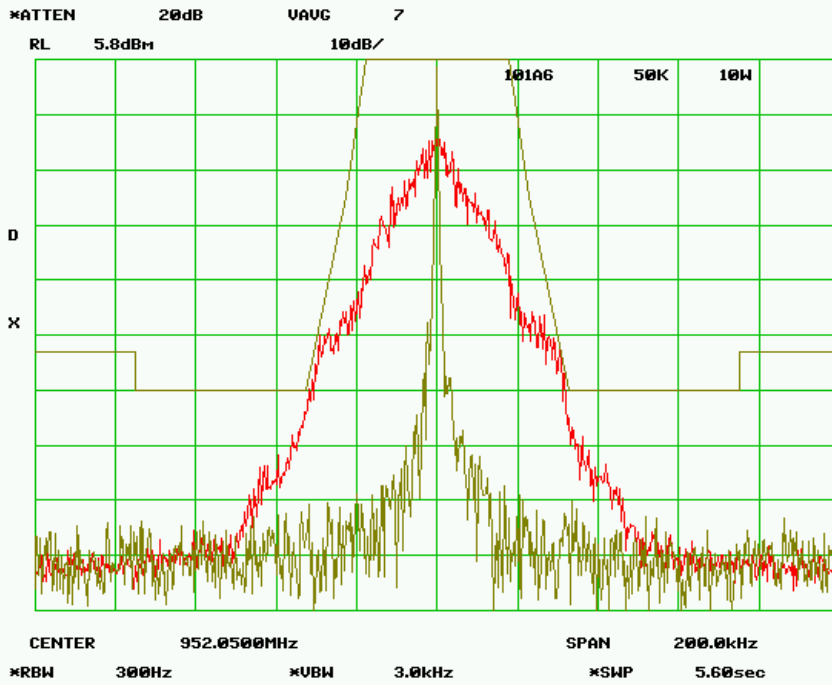

MASK 101.111a6 50 kHz- 1.0 Watt
RF Frequency 952.050 MHz
SPECTRUM FOR EMISSION - 30K0F1D
Data Rate = 64 kbps
PEAK DEVIATION = 11.02 kHz

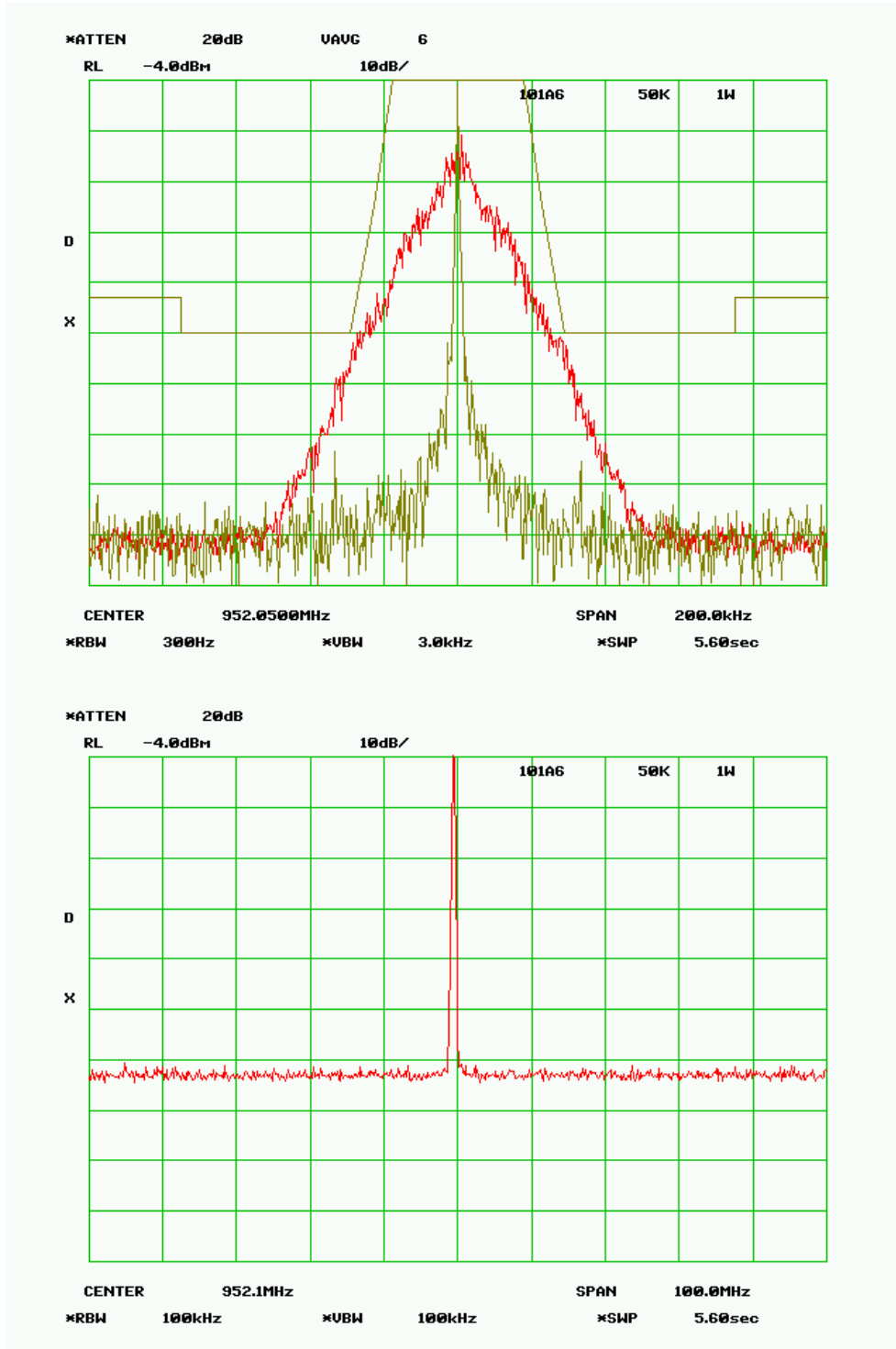

MASK 101.111a6 50 kHz- 10 Watts
RF Frequency 952.050 MHz
SPECTRUM FOR EMISSION - 30K0F1D
Data Rate = 64 kbps
PEAK DEVIATION = 11.02 kHz

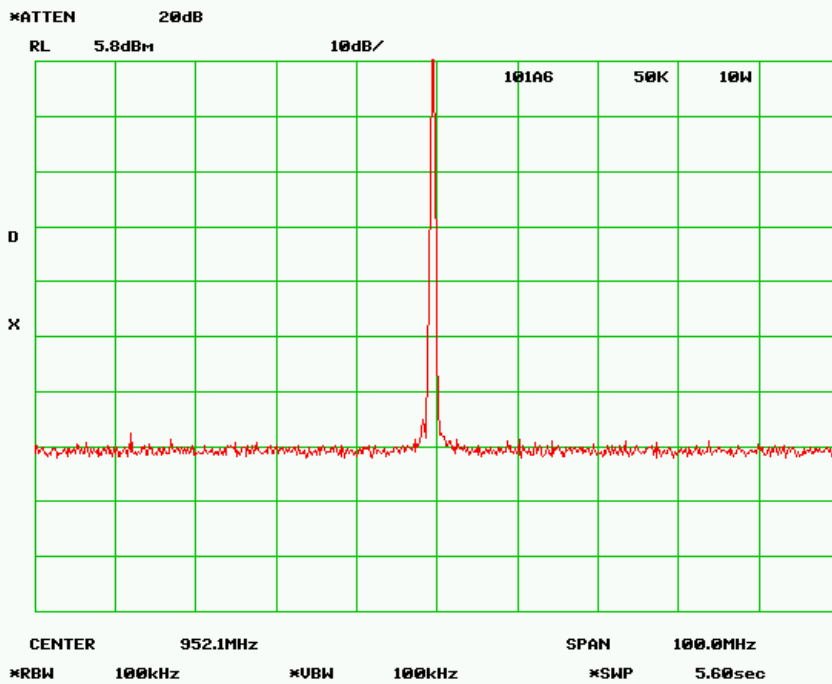
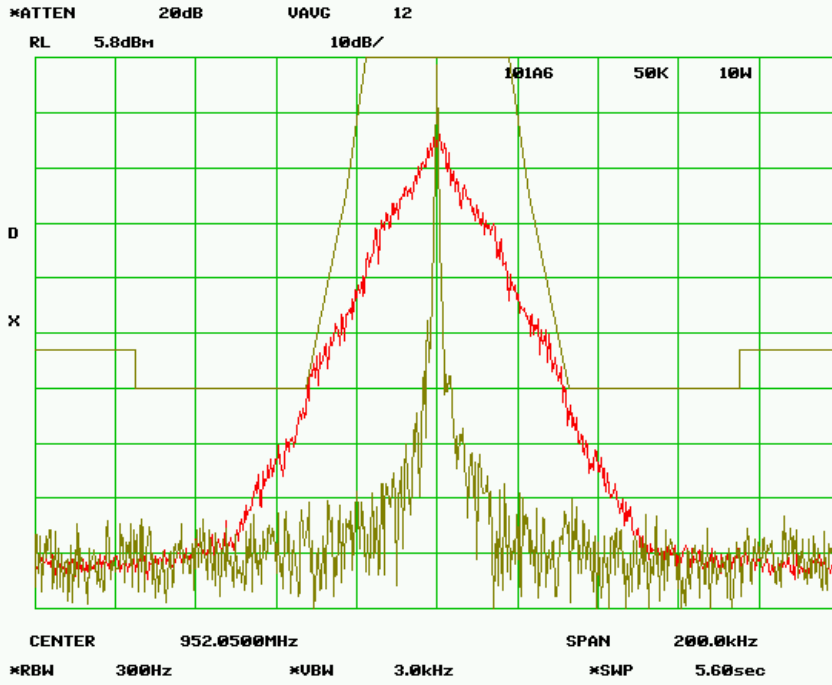

MASK 101.111a6 50 kHz- 1.0 Watt
RF Frequency 952.050 MHz
SPECTRUM FOR EMISSION - 29K5F1D
Data Rate = 96 kbps
PEAK DEVIATION = 10.81 kHz

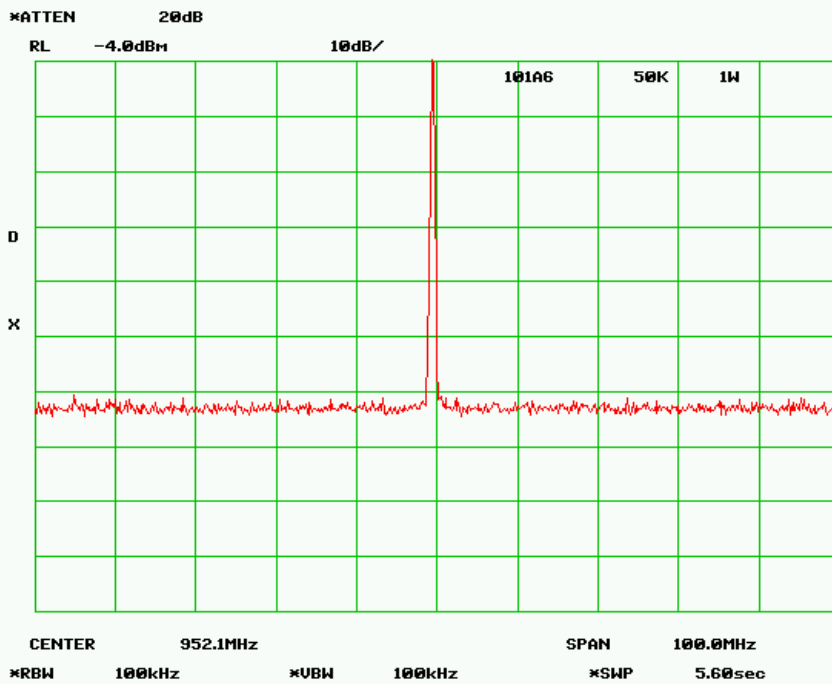
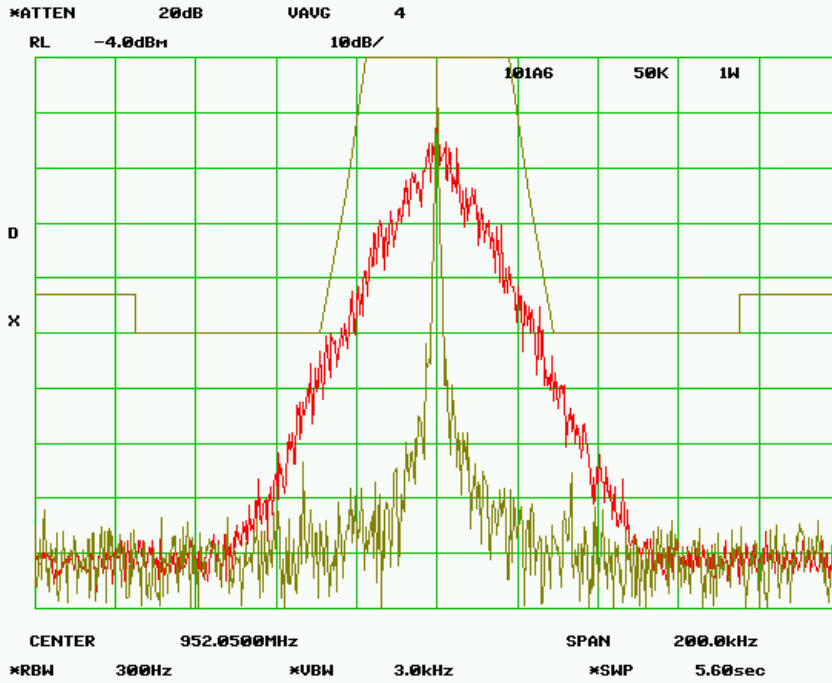

MASK 101.111a6 50 kHz- 10 Watts
RF Frequency 952.050 MHz
SPECTRUM FOR EMISSION - 29K5F1D
Data Rate = 96 kbps
PEAK DEVIATION = 10.81 kHz

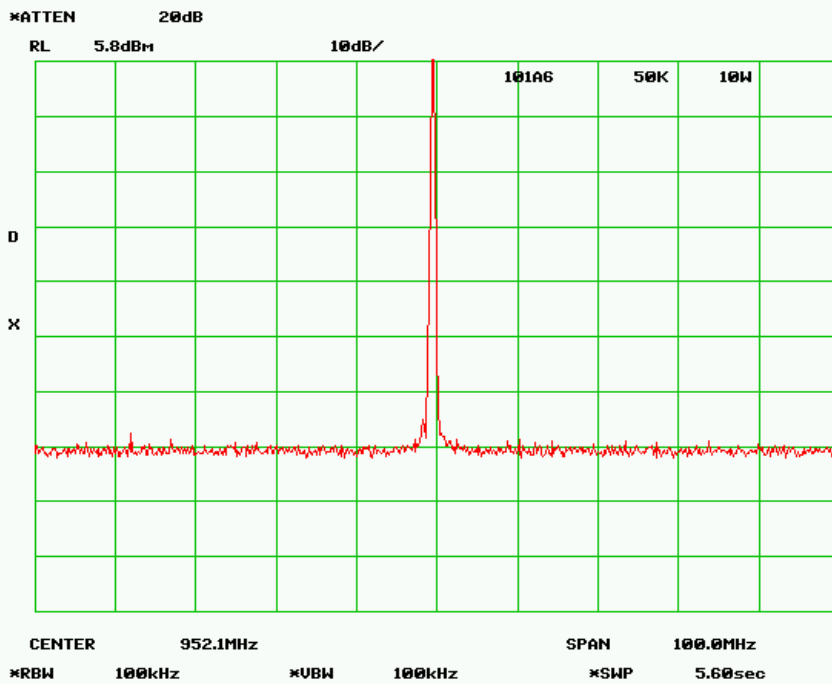
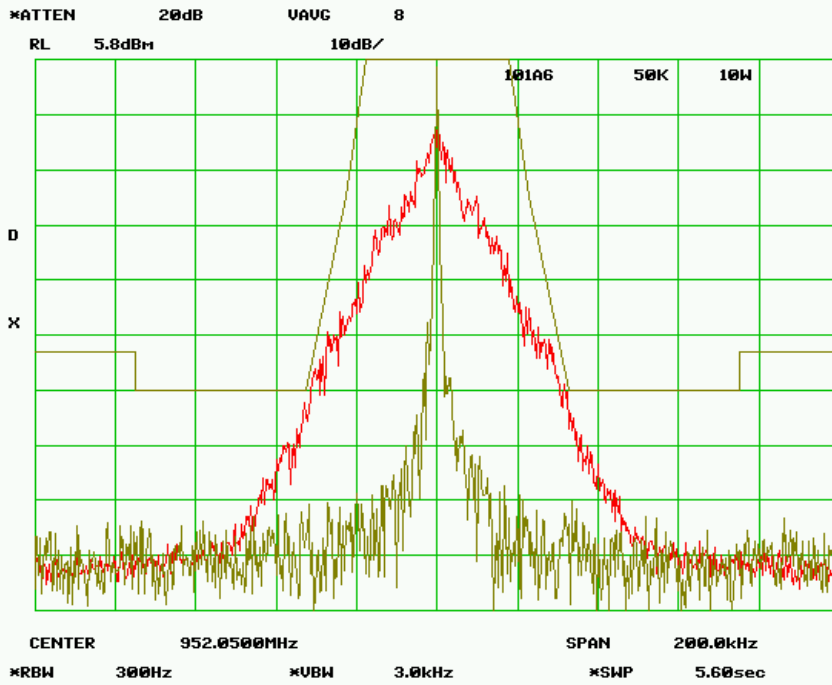

MASK 101.111a6 50 kHz- 1.0 Watt
RF Frequency 952.050 MHz
SPECTRUM FOR EMISSION - 30K5F1D
Data Rate = 128 kbps
PEAK DEVIATION = 11.66 kHz

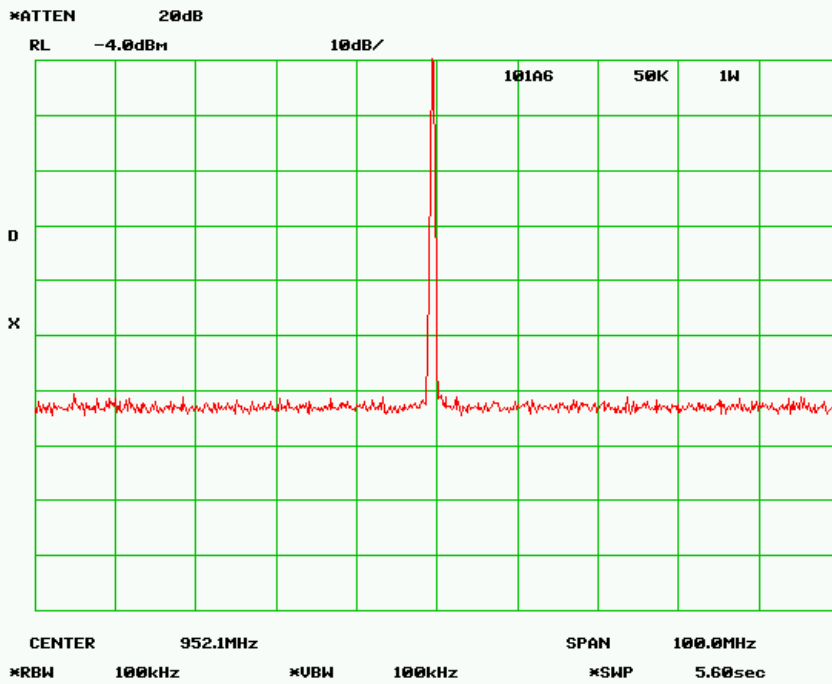
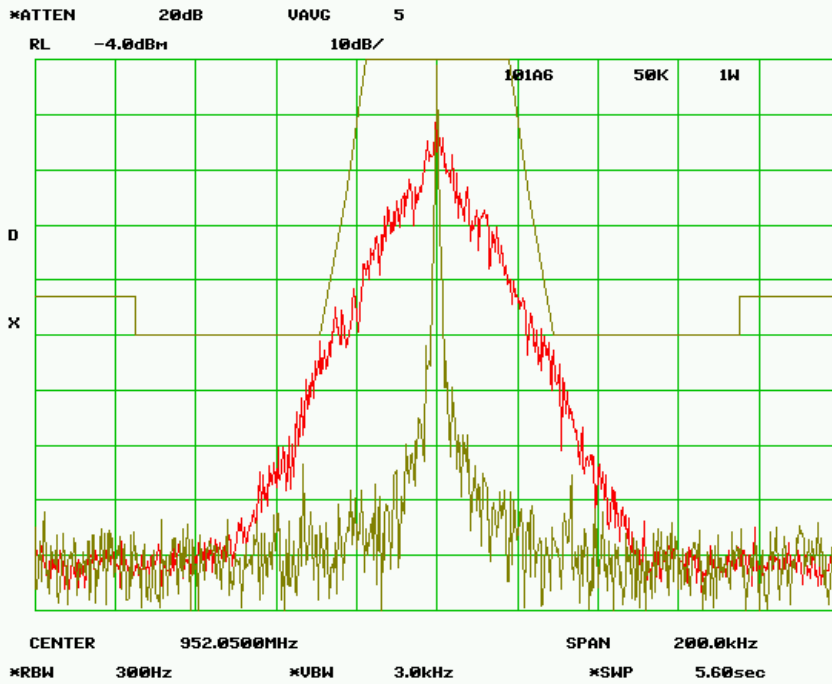

MASK 101.111a6 50 kHz- 10 Watts
RF Frequency 952.050 MHz
SPECTRUM FOR EMISSION - 30K5F1D
Data Rate = 128 kbps
PEAK DEVIATION = 11.66 kHz

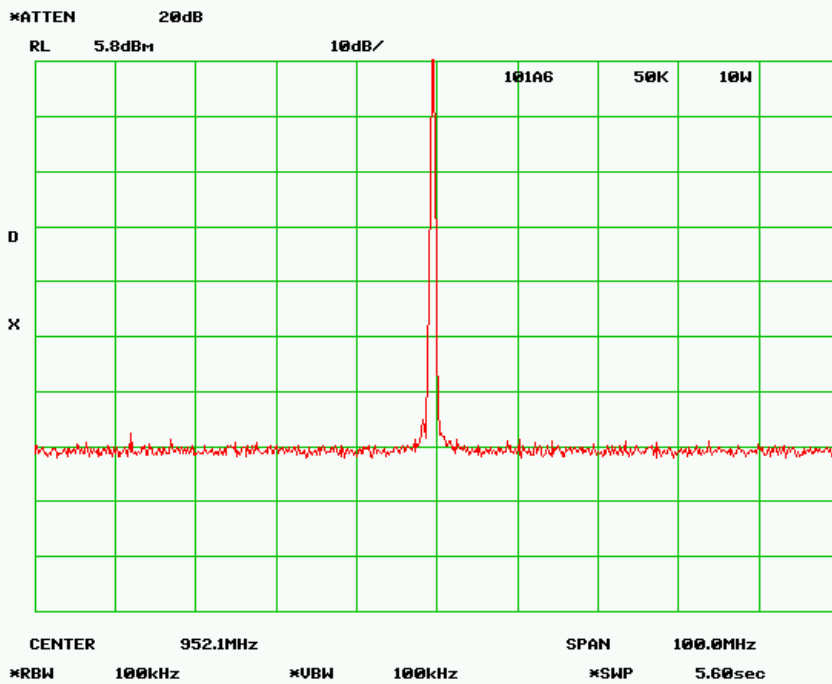
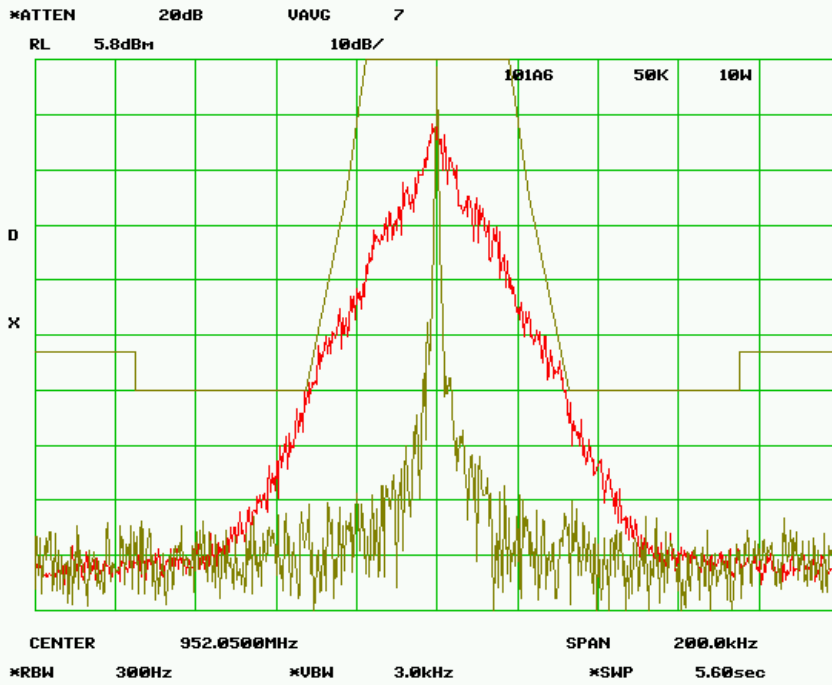

21.0 Part 101.111(a)(6) – 100 kHz ABW

NAME OF TEST: Transmitter Occupied Bandwidth for Emission Designators
51K0F1D, 52K7F1D, 49K7F1D, 51K3F1D

RULE PART NUMBER: FCC: 2.202, 2.1049 (c) (1), 101.109, 101.111 (a)(6)

MINIMUM STANDARDS: **Mask 101.111(a)(6) 100 kHz**
 Sidebands and Spurious [P = 10 Watts and P=1 Watt]
 Authorized Bandwidth = 100 kHz
 From Fo to 42.5 kHz, down 0 dB.
 From 42.5 kHz to 47.5 kHz, down $83 * \log_{10}(f_d / 5)$ dB
 Greater than 47.5 kHz to 250% auth BW, down $116\log(fd/6.1)$
 or $50+10\log(P)$ or 70 dB.
 Greater than 250% auth BW, $43+10\log_{10}(P)$ or 80 dB.

Attenuation = 0 db at Fo to 42.5 kHz
 Attenuation = 25 dB at 47.5 kHz
 Attenuation = 60 dB at 57.6 kHz @ 10W
 Attenuation = 50 dB at 54.0 kHz @ 1W
 Attenuation = 53 dB at > 100 kHz @ 10W
 Attenuation = 43 dB at > 100 kHz @ 1W

TEST RESULTS: Meets minimum standards (see data on following page)

TEST CONDITIONS: Standard Test Conditions, 25 C
 RF Power Level = 1 Watt and 12 Watts
 Voltage = 20VDC

TEST PROCEDURE: TIA/EIA – 603-C, 2.2.13, 3.2.11.2

TEST EQUIPMENT: 50-Ohm Attenuator, Bird Electronics Model 50-A-FFN-20 (20dB, 50W)
 50-Ohm Attenuator, Bird Electronics Model 10-A-MFN-10 (10dB, 10W)
 50-Ohm Attenuator, Pasternack Model PE7002-10 (10dB)
 DC Power Supply, Hewlett Packard Model 6653A
 Spectrum Analyzer, Hewlett Packard Model HP8563E
 Modulation Analyzer, Hewlett Packard Model HP8901A

TEST SET-UP:

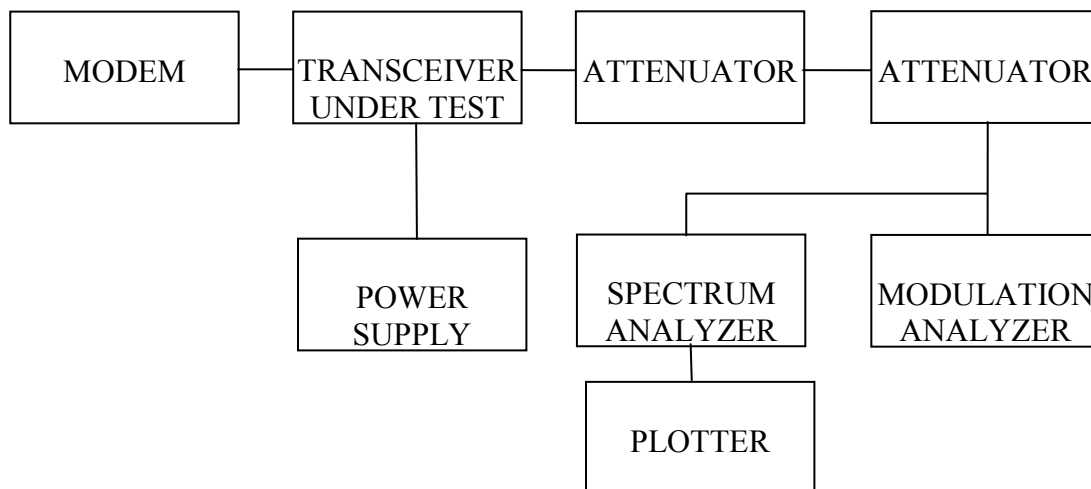

MASK 101.111a6 100 kHz- 1.0 Watt
RF Frequency 952.050 MHz
SPECTRUM FOR EMISSION - 51K0F1D
Data Rate =64 kbps
PEAK DEVIATION = 10.81kHz

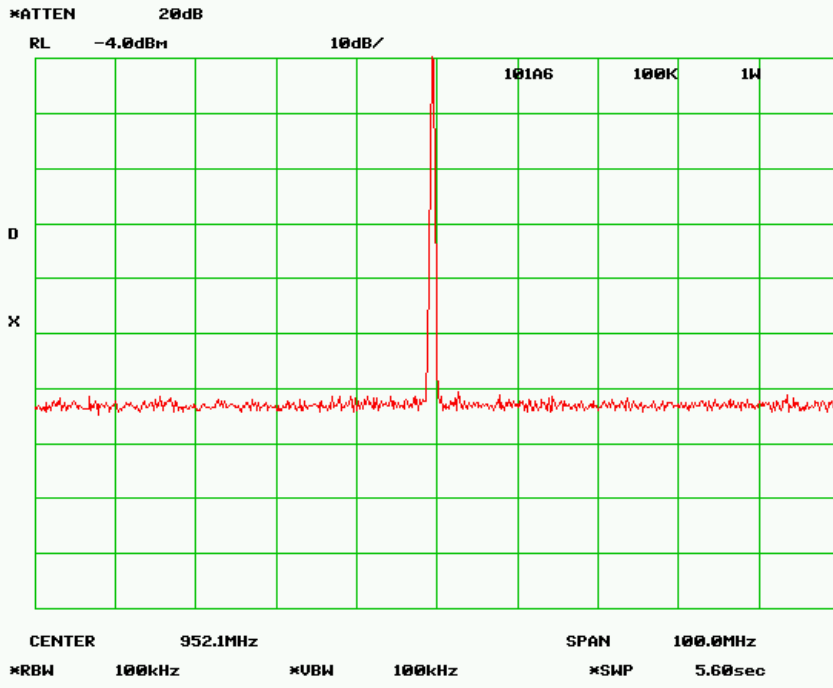
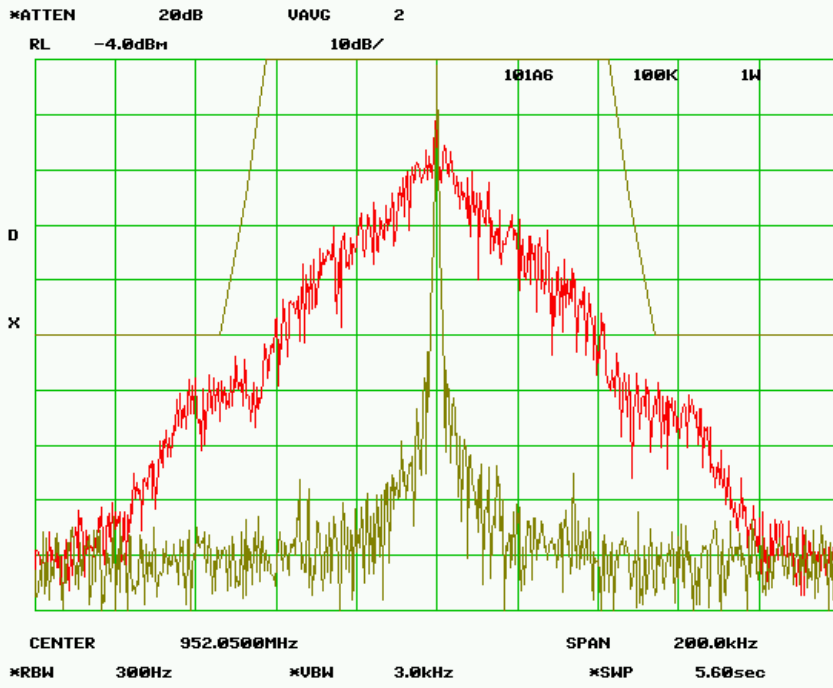

MASK 101.111a6 100 kHz- 10.0 Watt
RF Frequency 952.050 MHz
SPECTRUM FOR EMISSION - 51K0F1D
Data Rate =64 kbps
PEAK DEVIATION = 10.81kHz

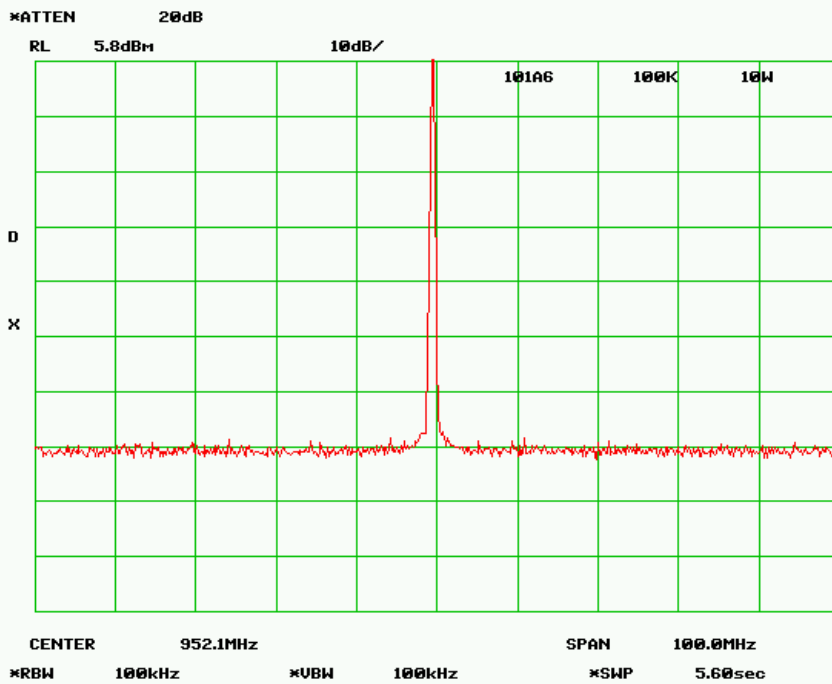
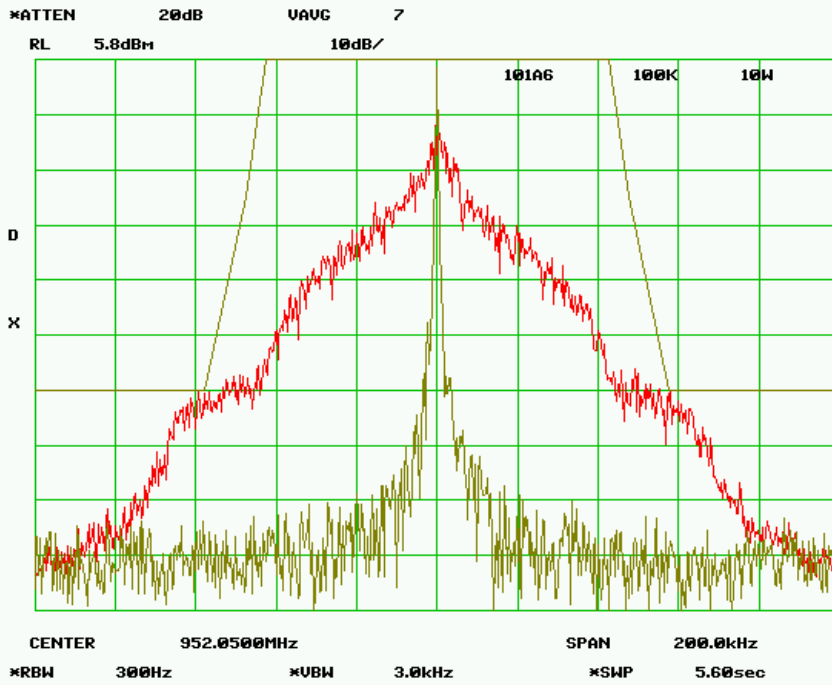

MASK 101.111a6 100 kHz- 1.0 Watt
RF Frequency 952.050 MHz
SPECTRUM FOR EMISSION - 52K7F1D
Data Rate = 128 kbps
PEAK DEVIATION = 12.40kHz

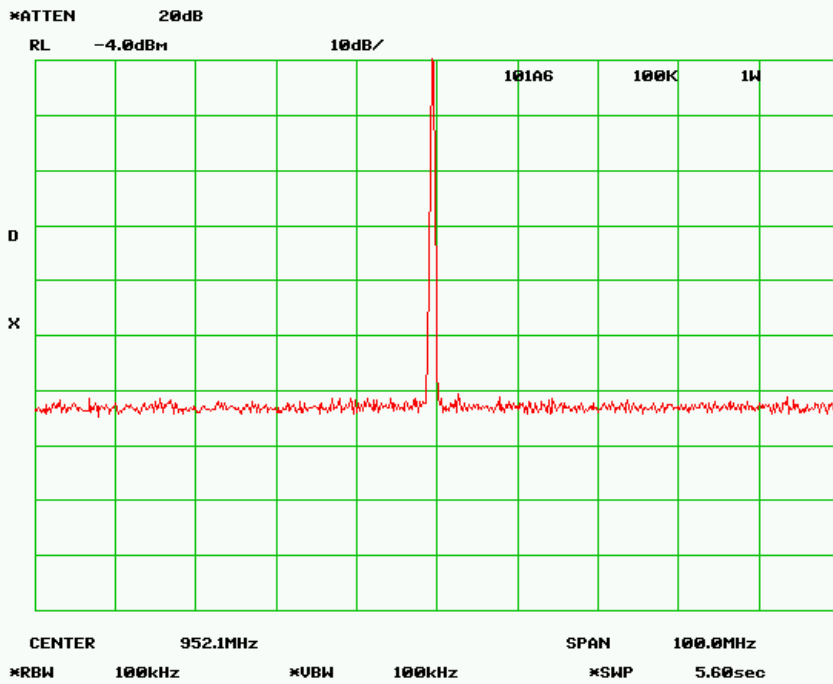
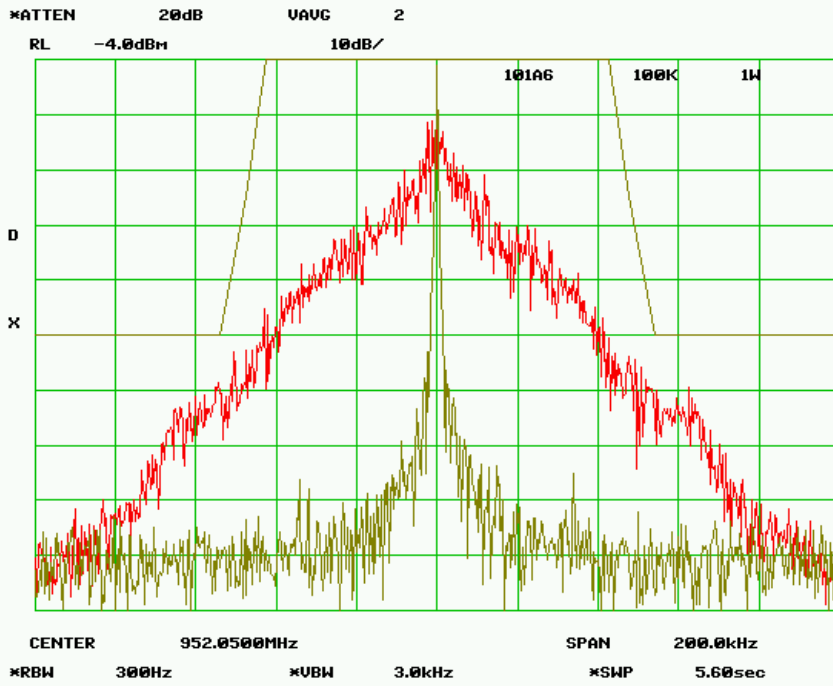

MASK 101.111a6 100 kHz- 10 Watts
RF Frequency 952.050 MHz
SPECTRUM FOR EMISSION - 52K7F1D
Data Rate = 128 kbps
PEAK DEVIATION = 12.40kHz

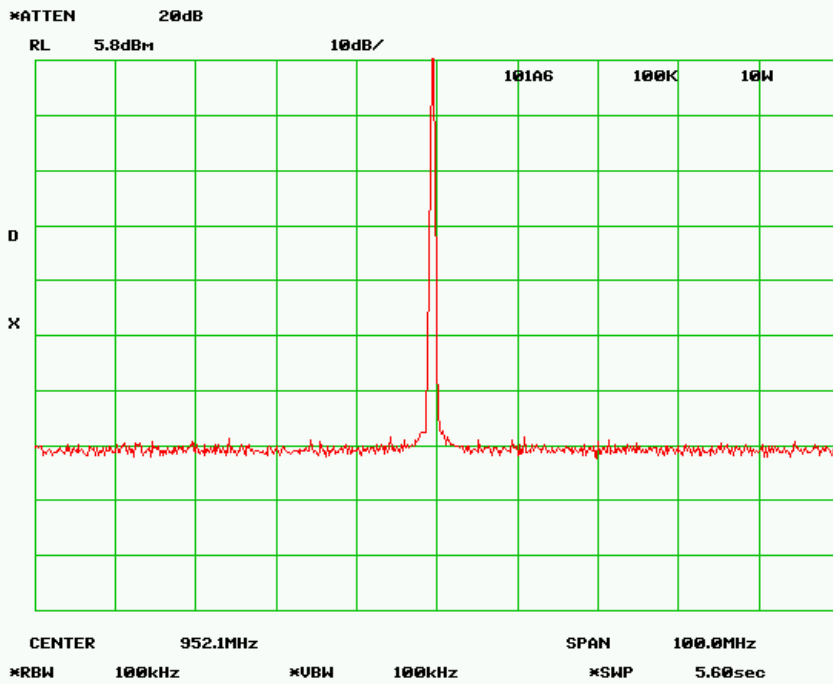
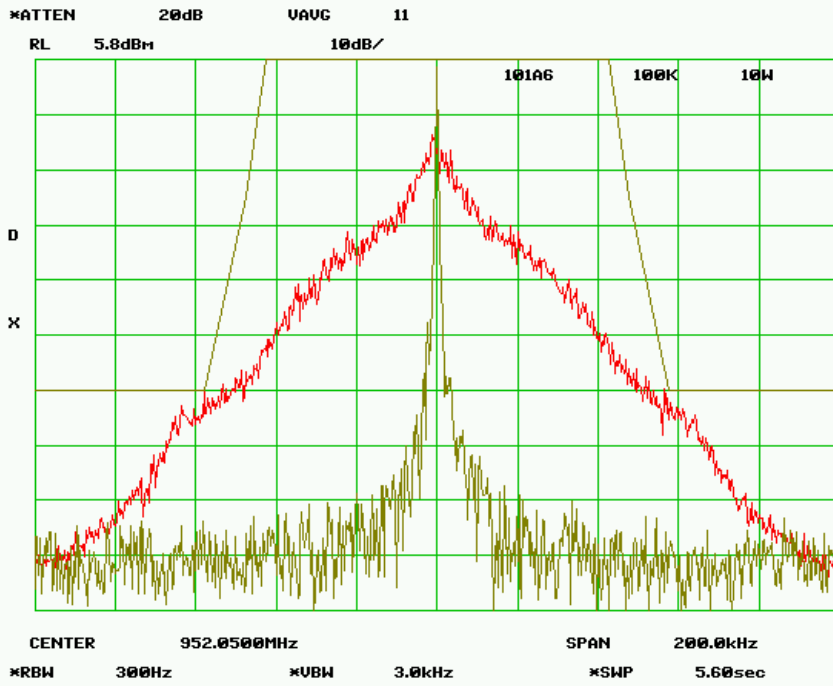

MASK 101.111a6 100 kHz- 1.0 Watt
RF Frequency 952.050 MHz
SPECTRUM FOR EMISSION - 49K7F1D
Data Rate = 192kbps
PEAK DEVIATION = 13.02 kHz

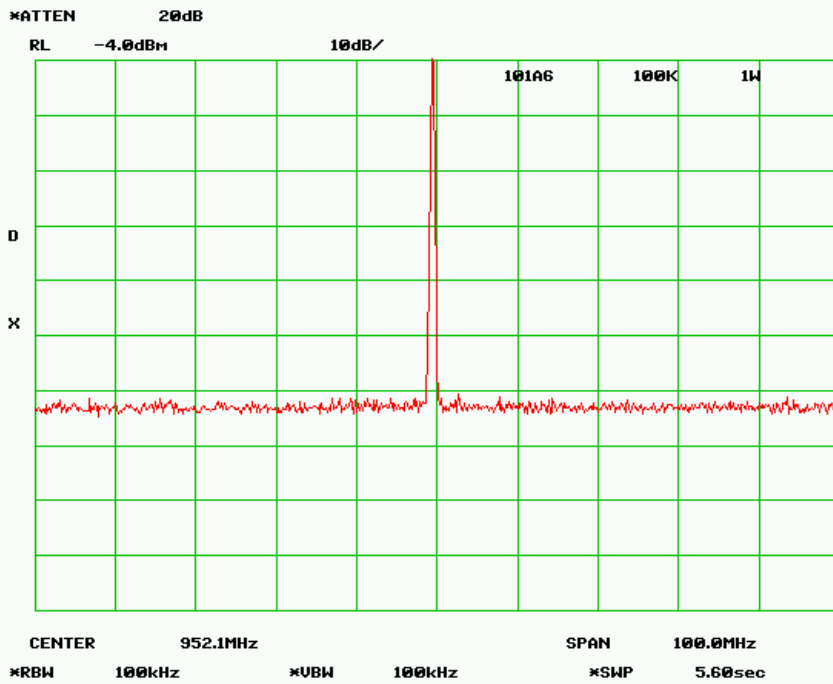
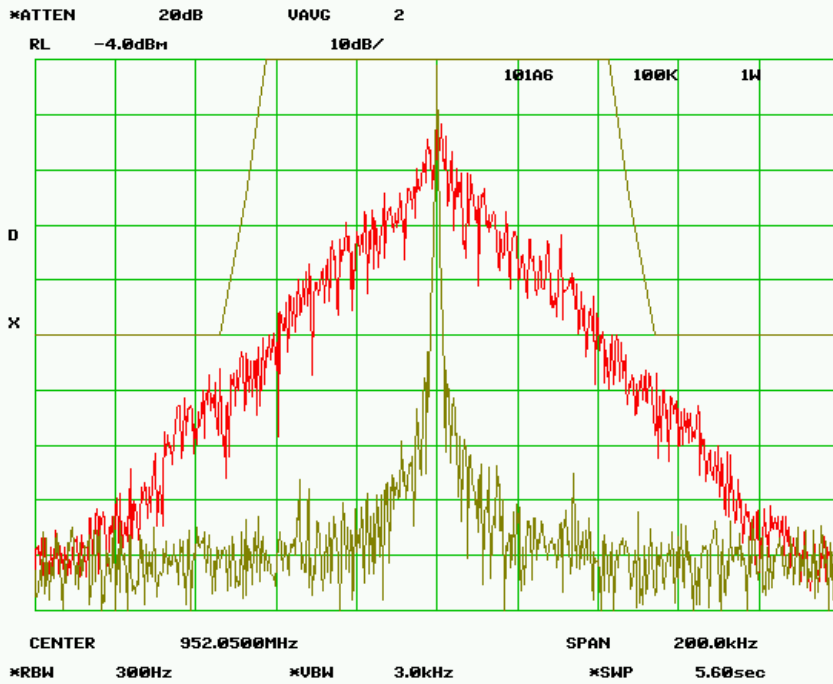

MASK 101.111a6 100 kHz- 10 Watts
RF Frequency 952.050 MHz
SPECTRUM FOR EMISSION - 49K7F1D
Data Rate = 192kbps
PEAK DEVIATION = 13.02 kHz

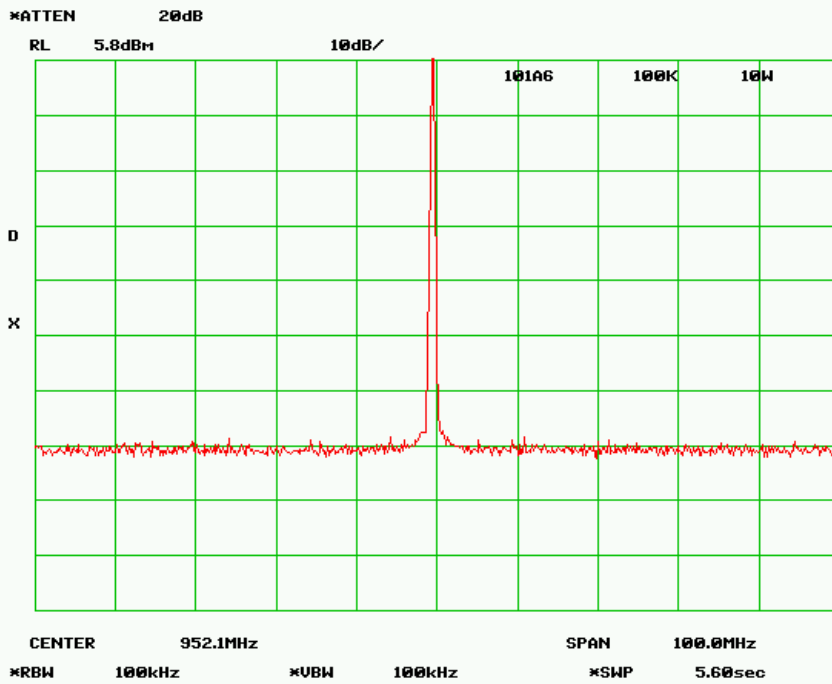
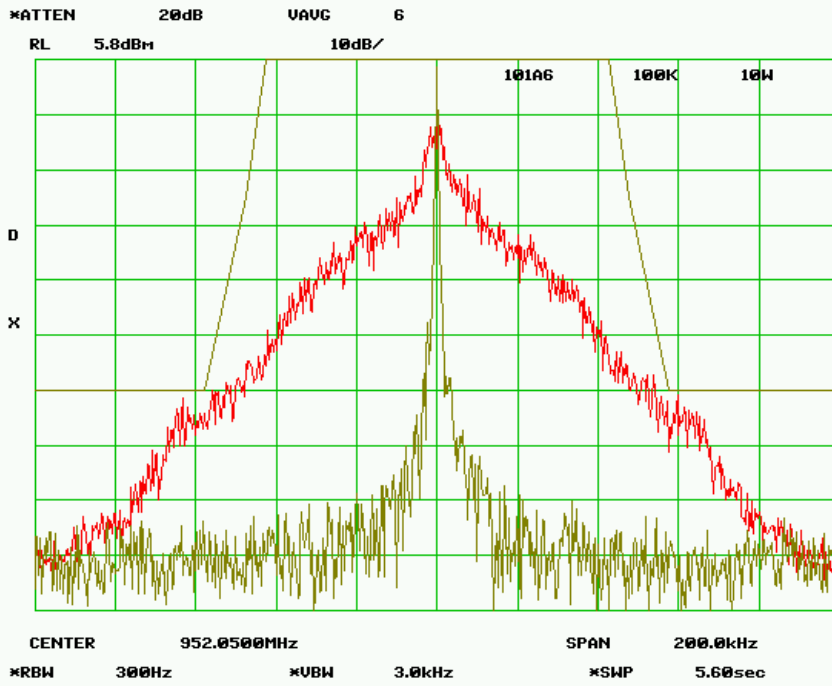

MASK 101.111a6 100 kHz- 1.0 Watt
RF Frequency 952.050 MHz
SPECTRUM FOR EMISSION - 51K3F1D
Data Rate = 256kbps
PEAK DEVIATION = 13.77 kHz

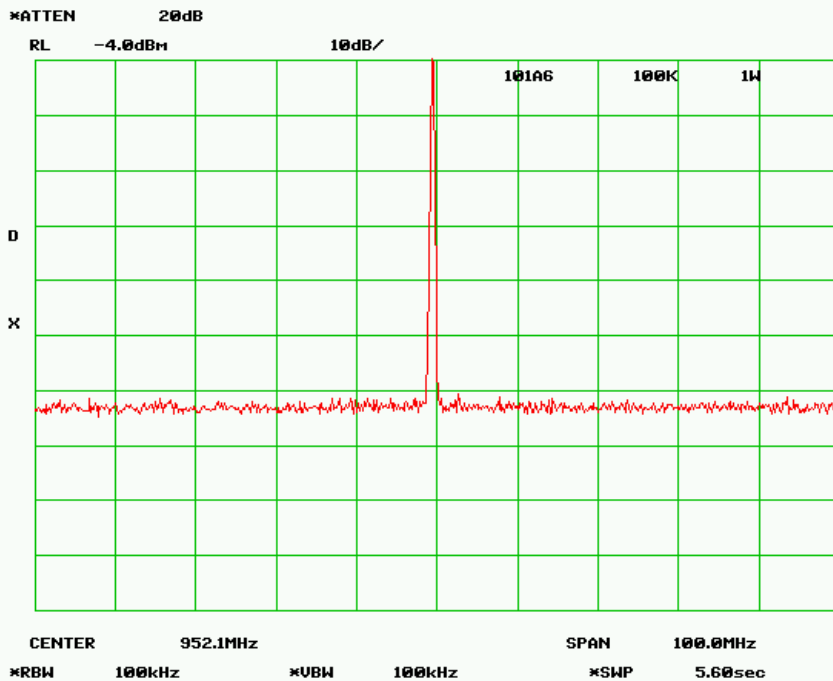
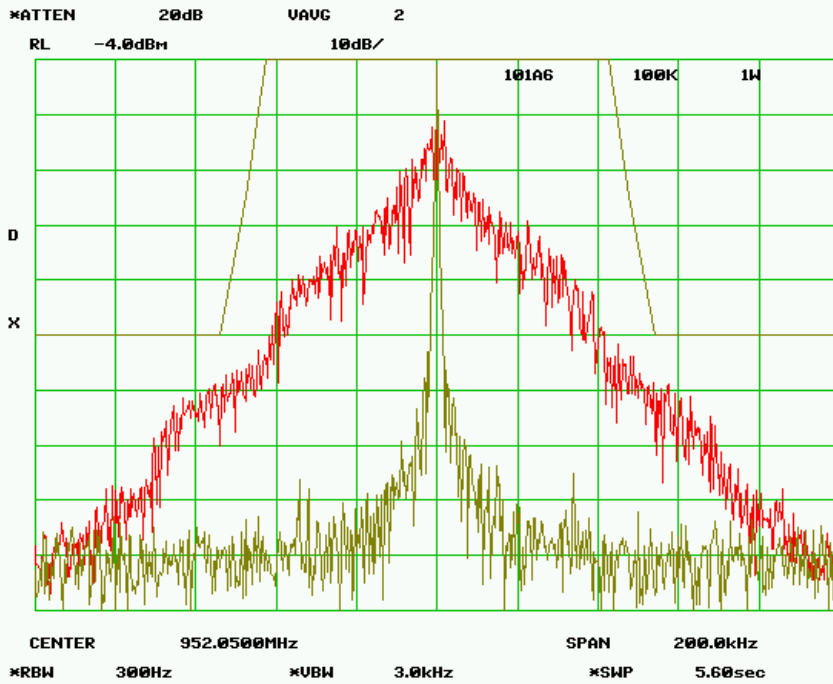

MASK 101.111a6 100 kHz- 10 Watts
RF Frequency 952.050 MHz
SPECTRUM FOR EMISSION - 51K3F1D
Data Rate = 256kbps
PEAK DEVIATION = 13.77 kHz

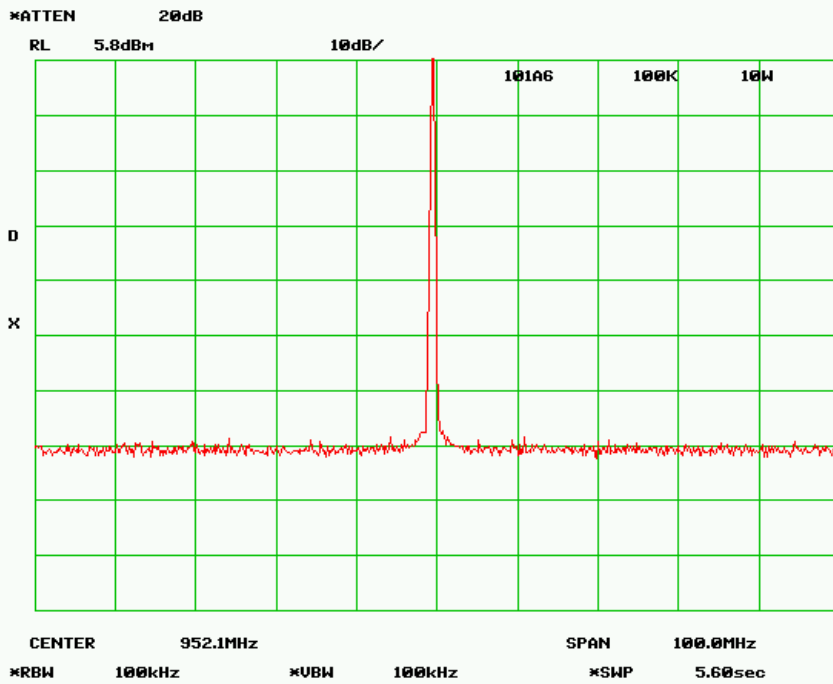
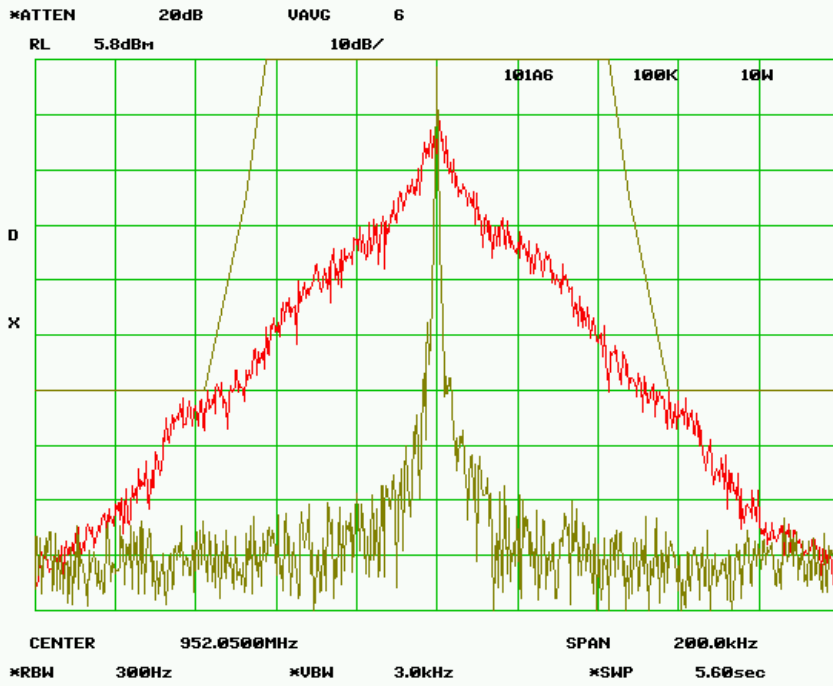

22.0 Calibration Information

Equipment	Serial Number	Cal Date	Cal Due
HP 8563E Spectrum Analyzer	3350A01938	6/19/2013	6/19/2014
Agilent E8257D Signal Generator	MY44320507	6/19/2013	6/19/2014
HP 8901A Modulation Analyzer	2924A02774	6/19/2013	6/19/2014
HP 437B Power Meter	3125U22336	6/19/2013	6/19/2014

Instruments have been calibrated using standards with accuracies traceable to NIST standards.