

**T-96H**  
**Radio Modem**  
**Technical Manual**  
**version 0.01**

**PRELIMINARY**

The entire contents of this manual and the Radio Service Software described in this manual are copyright 1998 by DATARADIO Inc.

Copyright DATARADIO Inc.  
August 1998

part no.: 120 10504-001

# Table of Contents

<b>1. PRODUCT OVERVIEW</b>	<b>1</b>
1.1 INTENDED AUDIENCE	1
1.2 INTRODUCTION	1
1.3 GENERAL DESCRIPTION	1
1.4 PHYSICAL DESCRIPTION	1
1.5 CONFIGURATION	1
1.6 CATALOG NUMBERS	2
1.7 FACTORY TECHNICAL SUPPORT	2
1.8 PRODUCT WARRANTY	2
1.9 REPLACEMENT PARTS	2
1.9.1 <i>Factory Repair</i>	2
1.10 DIAGNOSTICS AND REMOTE COMMANDS	3
1.10.1 <i>Addressing</i>	3
1.10.2 <i>Online Diagnostics</i>	3
1.10.3 <i>Offline Diagnostics</i>	4
1.10.4 <i>Remote Commands</i>	4
1.11 NETWORK CONFIGURATION	4
1.11.1 <i>Basic Network</i>	4
1.11.2 <i>Network Using T-Base</i>	5
1.11.3 <i>Network Using T-Base Repeater</i>	5
1.11.4 <i>Network Using T-96H for Online Diagnostics</i>	6
<b>2. FEATURES AND OPERATION</b>	<b>7</b>
1.1 OVERVIEW	7
2.1 INTENDED AUDIENCE	7
2.2 FRONT PANEL	7
2.2.1 <i>LED Indicators</i>	7
2.3 DTE PORT INTERFACE	7
2.3.1 <i>RS-232 Interface Signal Levels</i>	7
2.3.2 <i>Interface Port</i>	8
2.3.3 <i>Interface Signal Description</i>	8
2.4 CHANNEL SELECTION	9
2.5 OPERATION	9
2.5.1 <i>RTS/CTS Timing</i>	10
2.5.2 <i>XTAL mode</i>	10
2.5.3 <i>Extended Turnoff</i>	10
<b>3. ADJUSTMENTS AND MAINTENANCE</b>	<b>11</b>
1.1 OVERVIEW	11
3.1 INTENDED AUDIENCE	11
3.2 EQUIPMENT REQUIRED	11
3.3 MAINTENANCE INTERVALS	11
3.4 T96H ADJUSTMENTS	11
3.4.1 <i>Preliminary Verification</i>	11
3.4.2 <i>Basic Adjustments</i>	11
3.4.3 <i>Tests &amp; adjustments</i>	11
3.4.4 <i>Opening the Unit</i>	14
3.4.5 <i>Location of Adjustments and Test Points</i>	14
3.4.5.1 <i>All Models, Logic PCB</i>	14
<b>4. LOADER/MODEM BOARD CIRCUIT DESCRIPTION</b>	<b>14</b>
4.1 GENERAL	14

4.2 TRANSMIT DATA .....	14
4.3 RECEIVE DATA.....	15
4.4 SYNTHESIZER PROGRAMMING.....	15
4.5 POWER SUPPLIES .....	15
4.6 MISCELLANEOUS FUNCTIONS .....	15
<b>5. SPECIFICATIONS.....</b>	<b>17</b>
<b>INDEX.....</b>	<b>19</b>
FIGURE 1 - BASIC NETWORK.....	4
FIGURE 2 - NETWORK USING T-BASE .....	5
FIGURE 3 - USING A T-BASE REPEATER.....	5
FIGURE 4 - NETWORK WITH MONITORING SITE.....	6
FIGURE 5 - DATA I/O CONNECTOR PINOUT .....	7
FIGURE 6 - DIP SWITCH LOCATION .....	9
FIGURE 7 - LOGIC BOARD ADJUSTMENTS AND TEST POINTS .....	14
<i>TABLE 1 - RS-232 SIGNAL LEVELS .....</i>	<i>7</i>
TABLE 2 - CHANNEL SELECTION.....	9
TABLE 3 - RTS / CTS DELAYS.....	10
TABLE 4 - EXTENDED TURNOFF DELAYS.....	10
TABLE 5: TESTS AND ADJUSTMENTS <b>FULL CHANNEL</b> UNITS (25 KHZ & 30 KHZ MODELS).....	12
TABLE 6: TESTS AND ADJUSTMENTS <b>HALF CHANNEL</b> UNITS (12.5 KHZ & 15 KHZ MODELS).....	13

### **What's New in Version 0.01**

- First version of the T-96H technical manual based on the latest T-96S technical manual ver 2.01.

### **History**

Version 0.01:

- Preliminary version.

## Definitions

The following terms are used throughout this document.

<b><u>Item</u></b>	<b><u>Definition</u></b>
<b>Bit dribble</b>	Extraneous bits delivered at the end of a data transmission. Equivalent to a “squelch tail” in voice systems.
<b>DCE</b>	Data Communications Equipment. This designation defines the direction (input or output) of the various RS-232C interface signals. Modems are always wired as DCE. See also DTE.
<b>DTE</b>	Data Terminal Equipment. This designation defines the direction (input or output) of the various RS-232C interface signals. Most telemetry and SCADA equipment, as well as PCs, are wired as DTE. See also DCE.
<b>HDX</b>	Half Duplex. A unit which uses separate transmit and receive frequencies, but which may not transmit and receive simultaneously.
<b>OFLNDIAG</b>	Offline Diagnostics software. This software allows local (T-96S only) and remote diagnostics (T-96S and RNET 9600S).
<b>ONDMON</b>	Online Diagnostics Monitor software. This software allows online diagnostics monitoring of T-96S/DL3276 and RNET 9600S.
<b>PLC</b>	Programmable Logic Controller. An intelligent device that can make decisions, gather and report information, and control other devices.
<b>RS-232</b>	Industry–standard interface for low speed data transfer (EIA-RS-232E).
<b>RSS</b>	Radio Service Software. This software allows configuration and testing of the T-96S (T96RSS).
<b>RTS</b>	Request To Send. An RS-232C signal used by most SCADA equipment to initiate a data transmission.
<b>RTU</b>	Remote Terminal Unit. A SCADA device used to gather information or control other devices.
<b>SCADA</b>	Supervisory Control And Data Acquisition. A general term referring to systems that gather data and/or perform control operations.
<b>Simplex</b>	A unit which uses the same frequency for transmit and receive.
<b>Transparent</b>	A transparent unit transmits all data without regard to special characters, etc.
<b>T-96S</b>	The DATARADIO T-96S Telemetry Radiomodem. The T-Base is made up of 2 or 3 modified T-96S units.
<b>DL-3276</b>	The Johnson Data Telemetry (JDT) version of the T96S.
<b>T-96H</b>	Enhance version of the T-96S capable of 19200 b/s in full channel radio and 9600 b/s in half channel radio models.

# 1. PRODUCT OVERVIEW

This document provides the information required for the selection, installation, operation and maintenance of the DATARADIO T-96H radiomodem.

## 1.1 Intended Audience

This document is designed for use by engineering design, installation, and maintenance personnel.

## 1.2 Introduction

This chapter provides the information necessary to identify and assess the capabilities of the T-96H. Connection and operation are also described.

## 1.3 General Description

The T-96H is a transparent real-time radiomodem designed primarily for SCADA and telemetry use. The T-96H is available in different versions according to radio frequency. Common features to all versions include:

- Data speeds of 4800 to 19200 b/s (9600 b/s maximum in half channels) using standard RS-232 interface.
- Built-in 8 channel synthesized radio transceiver for VHF, UHF and 900 MHz.
- Power output of 1W to 5W (software controlled).
- Half duplex or simplex operation.
- Transmit switching via RTS.
- On-line diagnostics monitoring
- Offline local and remote diagnostics.
- Compatible with DATARADIO T-Base for base station or repeater use.
- Compatible with any  DATARADIO Interoperability Standard (DIOS) equipment for data rate up to 9600 b/s.

## 1.4 Physical Description

The T-96H consists of a logic PCB (which includes the modem circuitry) and a separate radio module. The two boards plug directly together and slide into the rails of an extruded aluminum case. The front panel includes the DE-15 data connector and a SMA antenna connector, as well as three LED indicators. Power connections are made through the DE-15 data connector. The unit is not hermetically sealed and should be mounted in a suitable enclosure where dust and/or a corrosive atmosphere are anticipated. There are no external switches or adjustments. Operating parameters are set using software.

Channel selection may be done using an internal DIP switch, by strapping the appropriate pins on the DE-15 data connector, or by selecting the desired channel using the T96HRSS or the OFLNDIAG.

## 1.5 Configuration

Operating characteristics of the T-96H are configured by means of *Radio Service Software* (T96HRSS - p/n 085 03250-xxx) available from your sales representative. Also available is the *Offline Diagnostics* software (OFLNDIAG) and the *Online Diagnostics Monitor* (ONDMON) which give access to offline diagnostics & commands (local and remote) and online diagnostics monitoring with or without a T-Base. Both programs are MSDOS based and will run on any 486 or higher PC (2 Megabytes memory required).

**The T-96H requires the use of the T96HRSS for both configuration and adjustment.**

## 1.6 Catalog Numbers

A T-96H may be identified from its catalog number.

### CATALOG NUMBERS

Format is TH[radio][band][channel spacing]0

#### radio

22	VHF		
12		UHF	
92			900

#### band (frequencies in MHz)

1		380 - 403	
2		403 - 419	
3		419 - 435	
4	132 - 150	435 - 451	
5	150 - 174	450 - 470	928 - 960
6		464 - 480	
7		480 - 496	
8		496 - 512	

#### channel spacing (frequencies in MHz)

1	15.0	12.5	12.5
3	30.0	25.0	25.0

For example, a TH12530 is a UHF, 450-470 MHz unit with 25 kHz channel spacing.

## 1.7 Factory Technical Support

The Technical Support departments of DATARADIO and Johnson Data Telemetry (JDT) provide customer assistance on technical problems and serve as an interface with factory repair facilities. They can be reached in the following ways:

DATARADIO Inc.  
5500 Royalmount Ave, suite 200  
Town of Mount Royal  
Quebec, Canada H4P 1H7

Technical support hours: Monday to Friday  
9:00 AM to 5:00 PM, Eastern Time,.

phone: +1 514 737-0020  
fax: +1 514 737-7883

Email address: [support@dataradio.com](mailto:support@dataradio.com)

Johnson Data Telemetry Corp.

Customer Service Department  
299 Johnson Avenue, P.O. Box 1733  
Waseca, MN 56093-0833

Technical support hours: Monday to Friday  
9:00 AM to 5:00 PM, Central Time,.

phone: 800 992-7774 and  
+1 507 835-6911

fax: 507 835-6969

Email address: [support@johnsondata.com](mailto:support@johnsondata.com)

## 1.8 Product Warranty

Warranty information may be obtained by contacting your sales representative.

## 1.9 Replacement Parts

This product is normally not field serviceable, except by the replacement of complete units. Specialized equipment and training is required to repair logic boards and radio modules.

Contact Technical Support for service information before returning equipment. A Technical Support representative may suggest a solution eliminating the need to return equipment.

### 1.9.1 Factory Repair

When returning equipment for repair, you must request an RMA (Returned Material Authorization) number. The Tech Support representative will ask you several questions to clearly identify the problem. Please give the representative the name of a contact person who is familiar with the problem, should questions arise during servicing of the unit.

Customers are responsible for shipping charges for returned units. Units in warranty will be repaired free of charge unless there is evidence of abuse or damage beyond the terms of the warranty. Units out of warranty will be subject to service charges. Information about these charges is available from Technical Support.

## 1.10 Diagnostics and Remote Commands

Diagnostics and remote commands are processed using the T96H Offline Diagnostics software (OFLNDIAG). Diagnostics can be monitored using the T96H Online Diagnostics Monitor program (ONDMON).

The T-96H has the following diagnostic and command features:

**Online diagnostics.** Information is automatically sent by each unit at the beginning of every transmission. May be disabled for back compatibility with DATARADIO T-Modem 96 or Motorola RNET 9600.

**Offline diagnostics.** Information is sent by a specific unit in response to an inquiry by the master or monitoring station.

**Remote commands.** Commands may be sent by the master or monitoring station to any specific remote unit.

### 1.10.1 Addressing

Each T-96H has addressing capability which is used for diagnostics and remote commands **only**. Two addresses are used:

**ID Number:** This value (maximum 1023) is assigned at the factory but may be modified using the T96RSS. The *ID Number* is used to uniquely identify the T-96H for remote commands and offline diagnostics. The *ID Number* may have values within the range of 1 to 99,999,999 but **multiples of 1024 should not be used**.

**Short ID:** This value is the low order 10 bits of the *ID Number*. It is used to identify online diagnostics only. It may not be modified directly using the T96HRSS; it is always derived from the *ID Number*. All units within a network should have unique *Short ID* numbers to avoid ambiguity in Online Diagnostics reports.

Either the T96HRSS or OFLNDIAG may be used to check the value of the *Short ID*. When setting up a network, we recommend checking each unit to make sure that there is no duplication of *Short ID* numbers. Duplications may be resolved by changing the *ID Number*.

If *ID Numbers* are set so that their value is within the range of 1 to 1023, the *ID Number* and the *Short ID* will always have the same value. Customers may find this to be a convenience.

### 1.10.2 Online Diagnostics

Online diagnostics (statistics) require the use of a network configuration such as that specified in section 1.11.2. or 1.11.4 Online diagnostics do not interfere with normal network operation. The following information is gathered:

- Supply voltage
- Internal temperature
- Forward and reverse power in watts (T96S models only)
- Received signal strength in dBm

Each T-96H can accumulate these statistics for the last 15 stations heard. The accumulated values may be displayed using the OFLNDIAG or dynamically monitored by the Online Diagnostics Monitor program (ONDMON).



### 1.10.3 Offline Diagnostics

Offline diagnostics are statistics returned in response to a specific request to a particular station. The use of this feature requires that network operation temporarily be suspended.

The following information may be gathered and displayed via the OFLNDIAG:

- Supply voltage
- Analog supply voltage
- Internal temperature
- Received signal strength in dBm
- Forward and relected power in watts (T96S models only)

### 1.10.4 Remote Commands

The following commands may be sent remotely (using the OFLNDIAG).

- Begin test transmission (several types available).
- Get statistics (diagnostics).
- Sample network statistics (monitoring online diagnostics).
- Get parameters (configuration) from remote unit.

Sending remote commands and receiving responses is done with the host application offline.

## 1.11 Network Configuration

The T-96H is designed to replace wire lines in SCADA, telemetry and control applications. The RS-232 serial port allows direct connection to PLCs (Programmable Logic Controllers) or RTUs (Remote Terminal Units). Several network configurations are described in the sections that follow.

### 1.11.1 Basic Network

This configuration has the following characteristics:

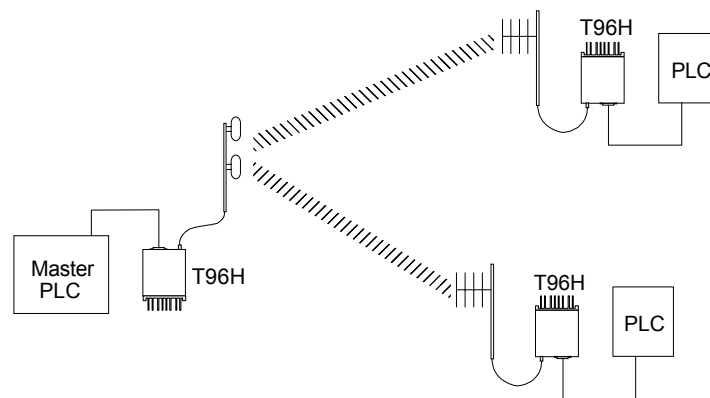

Figure 1 - Basic Network

- Master station may be half duplex or simplex.
- Online diagnostics are not available in real time.
- Remote and local diagnostics, accumulated online diagnostics and control are available by disconnecting the master PLC and substituting a PC running the T96H Offline Diagnostics software (OFLNDIAG).

### 1.11.2 Network Using T-Base

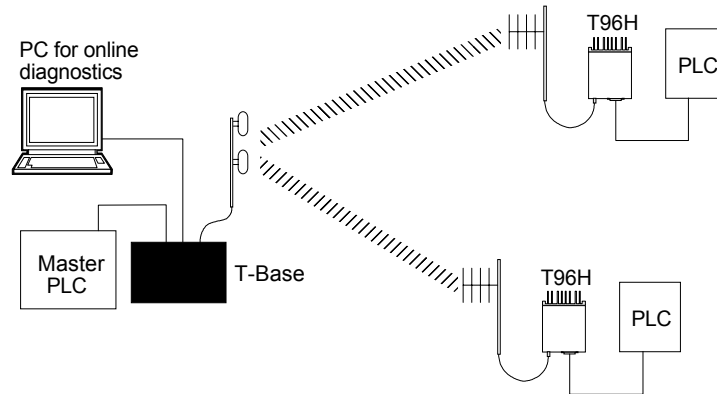

Figure 2 - Network Using T-Base

This configuration has the following characteristics:

- Master station may be full duplex (duplexer required), half duplex or simplex.
- Online diagnostics are available using the *Online Diagnostics Monitor* program (ONDMON) without disrupting network activity.
- Remote and local diagnostics, statistics and control are available using the T-96H OFLNDIAG.
- The T-Base provides output of online diagnostic information which could be processed by the T-96H ONDMON program or by a user-supplied network management program. Contact your sales representative for further information.

### 1.11.3 Network Using T-Base Repeater

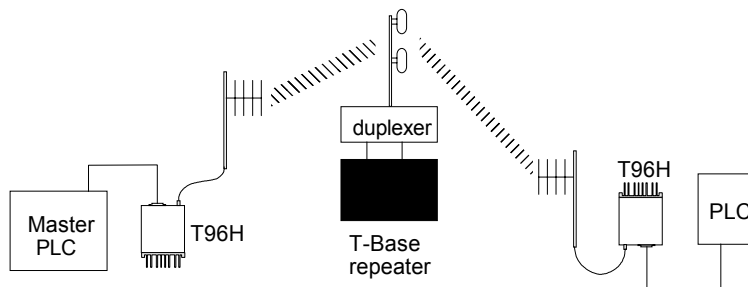

Figure 3 - Using a T-Base Repeater

This configuration has the following characteristics:

- Master station and all remotes must be half duplex.
- Any of the network types described in sections 1.11.1, 1.11.2 or 1.11.4 may be used with a T-Base repeater.
- The RTS/CTS delays for each T-96H in the system must be extended as shown in section 2.5.1

### 1.11.4 Network Using T-96H for Online Diagnostics

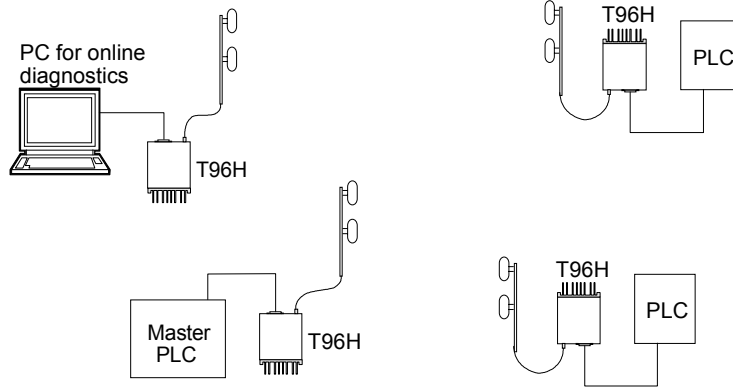

Figure 4 - Network with Monitoring Site

This configuration has the following characteristics:

- Master station may be half duplex or simplex.
- Accumulated online diagnostics for a maximum of 15 stations are available at a monitoring site (monitoring site must be in range of all remotes).
- Online diagnostics are available in real time at the monitoring site.
- Remote offline diagnostics, statistics and control are available from the monitoring site by temporarily disabling network activity.

Online diagnostics are accumulated in the monitoring T-96H for the last 15 stations heard. This information may be viewed using the OFLNDIAG. For larger networks, the T-96H can output raw diagnostic data only, which may be interpreted for network management by the Dataradio ONDMON program or by a user-supplied software program. Contact your sales representatives for more information.

## 2. Features and Operation

### 2.1 Overview

This chapter outlines the physical features, connections and theory of operation of the T-96H.

### 2.2 Intended Audience

This chapter is intended for use by engineering design, installation, and maintenance personnel.

### 2.3 Front Panel

The front panel includes:

- One SMA type female antenna connector.
- Three LED indicators (described below).
- One DE-15F interface (includes power connections)

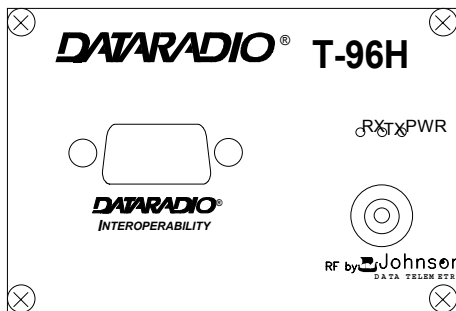

#### 2.2.1 LED Indicators

The T-96H has three LED indicators as shown described:

LED	Indicates	Description
Green	Power	DC Power is applied.
Flashing green	Setup mode	Unit is in setup mode.
Red	Transmit	Unit is transmitting a data signal.
Yellow	Receive	Unit is receiving a data signal.

### 2.3 DTE Port Interface

#### 2.3.1 RS-232 Interface Signal Levels

In the descriptions of data signals, the following conventions are used:

Table 1 - RS-232 Signal Levels

Term	Alternates	Signal level
ON	asserted, spacing	+3 to +15 V
OFF	dropped, marking	-3 to -15 V

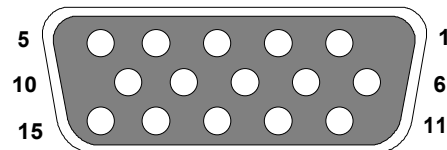

Pin	Name	Pin	Name	Pin	Name
1	Ground	6	Ground	11	CS 0
2	RX Data	7	CTS	12	CS 1
3	TX Data	8	RTS	13	CS 2
4	Test Audio	9	DCD	14	RSSI
5	B+ Power	10	B+ Power	15	DTR

Figure 5 - Data I/O Connector Pinout

### 2.3.2 Interface Port

The T-96H signals are defined as DCE. Connection to user DTE is made via a DE-15 female connector. This connection meets the *DATARADIO Interoperability Standard* (DIOS).

Users can build a suitable cable by referring to the connector pinout and the Interface Signal Description given in the next section. A cable for connection to a PC AT type DE-9 connector is available from DATARADIO as p/n 730 03267-001.

**Important Note:** The T96H RSS kit, used to configure the T-96H, includes a special setup cable, p/n 730 03266-001. **Do not use this cable to connect a user application.** Doing so will result in the T-96H switching to “setup mode”, in which case it will not transmit or receive user data. The green LED flashes to indicate that the unit is in this mode.

### 2.3.3 Interface Signal Description

**B+ power (input).** 10 - 16 VDC (13.3V nominal), maximum 2 A.

**RX Data.** Received data from T-96H to DTE.

**TX Data.** Transmit data from DTE to T-96H.

**CTS.** Clear to Send. Asserted when the T-96H is ready to accept TX Data.

**RTS.** Request to Send. Causes the T-96H to transmit when asserted by the DTE.

**DCD.** Data Carrier Detect. Asserted by the T-96H when a data signal is being received.

**DTR.** Data Terminal Ready. Asserted by the T96HRSS/OFLNDIAG to select setup mode. **Do not connect to this pin for user applications.**

**Test Audio.** Output signal used during adjustment and testing.

**RSSI.** Output signal used during testing.

## 2.4 Channel Selection

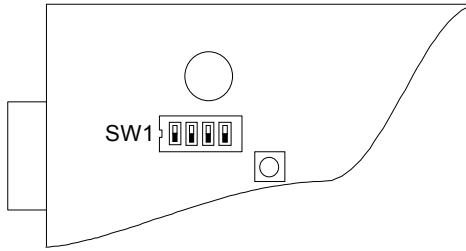

Figure 6 - DIP switch location

Channel frequencies for 8 channels are selected using the T96HRSS. Once selected, the current operating channel may be selected in one of three ways:

1. By setting the channel on the internal DIP switch. **CS0 to CS2 on the interface connector must be left disconnected.**
2. By strapping connections on the interface connector. There is a 10K $\Omega$  pull up resistor on each line (CS0 to CS2). **The DIP switch channel settings must be all OFF.**
3. By selecting the channel from the T96RSS or the OFLNDIAG programs. **The DIP switch channel settings must be all OFF and CS0 to CS2 on the interface connector must be disconnected (open).**

Table 2 - Channel Selection

Channel	SW1-3	SW1-2	SW1-1	CS 2	CS 1	CS 0
1	on	on	on	gnd	gnd	gnd
2	on	on	off	gnd	gnd	open
3	on	off	on	gnd	open	gnd
4	on	off	off	gnd	open	open
5	off	on	on	open	gnd	gnd
6	off	on	off	open	gnd	open
7	off	off	on	open	open	gnd
8	off	off	off	open	open	open

In the table, "gnd" indicates that the pin should be connected to ground (pin 1 or 6)

## 2.5 Operation

The T-96H operates transparently at the speed set using the Radio Service Software (T96HRSS) and is designed to operate unattended. Basic operation is as follows.

1. The DTE starts a data transfer by asserting RTS. CTS is returned after the transmitter has been keyed and a modem synchronization preamble sent.

See Table 3 - RTS / CTS Delays for actual value.

2. Data are transmitted as long as RTS is asserted and the PTT timer, if enabled, has not expired. RTS can be dropped after the last stop bit of the last character has been given to the T-96H. CTS will be dropped when the last character has been transmitted on the network.

3. In the idle mode, i.e. no transmission or reception, RX Data will be held in the idle (i.e. “marking”) condition.
4. When a valid radio data signal is received, DCD will be asserted and data will be delivered.
5. When the radio carrier is dropped, the T-96H will clamp RX Data idle (marking) again and drop DCD. At 19200 b/s a few extraneous bits may be delivered after the carrier is dropped (sometimes called “bit dribble”). User software should take this possibility into account.

### 2.5.1 RTS/CTS Timing

The T-96H asserts CTS after RTS has been asserted and a sufficient time has elapsed to allow modem synchronization. The times are fixed at the factory and are not user-adjustable.

*Repeater mode* (Extended time) must be set (via the T96HRSS) if the unit is to communicate through a repeater.

Times are increased if *online diagnostics* are enabled, as shown in the columns *diag. on*.

Table 3 - RTS / CTS Delays

Speed	RTS/CTS delay (normal)		RTS/CTS delay (extended)	
	diag. off	diag. on	diag. off	diag. on
1200 b/s	50 ms	144 ms	80 ms	174 ms
2400 b/s	40 ms	87 ms	70 ms	117 ms
4800 b/s	30 ms	54 ms	60 ms	84 ms
9600 b/s	30 ms	41 ms	60 ms	71 ms
19200 b/s	30 ms	36 ms	60 ms	66 ms

### 2.5.2 XTAL mode

This mode extends all RTS/CTS delays by 5 ms for compatibility with earlier, crystal controlled products (T-Modem 96, RNet 9600). Select this mode from the T96RSS.

### 2.5.3 Extended Turnoff

An end-of-transmission quiet period approximately 8 characters long can be invoked on the T-96H by holding its transmitter on briefly after RTS is dropped. This quiet period, which occurs between the last valid data character and any possible extraneous “noise” bits, may be of benefit to some DTE

that would otherwise be adversely affected by the extraneous bits. This quiet period is selected via the T96RSS.

Table 4 - Extended Turnoff Delays

Speed	Quiet “turnoff” period
1200 b/s	70 ms
2400 b/s	35 ms
4800 b/s	16 ms
9600 b/s	8 ms
19200 b/s	4 ms

## 3. Adjustments and Maintenance

### 1.1 Overview

This chapter outlines the basic adjustment procedures required upon initial installation and thereafter at prescribed maintenance intervals. Units are delivered from the factory properly aligned and tested on the frequencies specified at time of order. Adjustment beyond that described in this chapter is not required unless radio modules have been tampered with or repaired. In such cases we recommend complete factory re-alignment as special test jigs are required.

### 3.1 Intended Audience

This chapter is intended for use by installation and maintenance personnel.

### 3.2 Equipment Required

The adjustments described below require the following equipment:

- 13.3 VDC (nominal), 3A regulated power supply.
- Radio service monitor (IFR or equivalent).
- Cable with SMA-male connector to connect T-96H to the service monitor.
- T96H Radio Service Software (T96HRSS) kit, including setup cable (p/n 085 03250-xxx)
- A 486 PC (or better) to run the T96HRSS.
- Normal radio shop tools.

### 3.3 Maintenance Intervals

The adjustments described below should be done once upon initial installation of the unit, and thereafter at annual intervals or whenever a deterioration in performance indicates that adjustment may be required.

## 3.4 T96H Adjustments

### 3.4.1 Preliminary Verification

Before performing any adjustments, verify the performance of the unit as shown in the Table 5 for *full channel units* in the Table 6 for *half channel units*.

**Important Note: Before proceeding make sure that the service monitor has been calibrated recently and has warmed up for at least the time specified by its manufacturer.**

Some reported frequency and deviation problems have actually been erroneous indications from service monitors that have not adequately warmed up. This is particularly likely when field service is done during winter months.

### 3.4.2 Basic Adjustments

Basic adjustments to be performed are:

1. Transmitter power output
2. TX/RX frequency
3. Transmitter deviation
4. Demodulated audio level

These adjustments should be performed in the sequence shown above.

### 3.4.3 Tests & adjustments

Refer to the T96HRSS help file for parameter information.

1. Connect the T-96H antenna connector to the TX/RX input of the service monitor using a suitable length of 50 ohm cable.
2. Connect the T-96H to a suitable power supply and adjust the supply voltage to 13.3 volts.
3. Using the setup cable (p/n 730 03266-001; part of kit 085 03250-xxx) connect the T-96H Data connector to the serial port of a PC and run the T96HRSS program. This cable is required to put the T-96H into *setup mode*.
4. Press *GET* to get the configuration of the unit.
5. Refer to “*Tests and Adjustments*” tables related to the radio type (half or full channel).



Table 5: Tests and Adjustments **full channel** units (25 KHz & 30 Khz models)

STEP	ACTION	EXPECTED RESULTS at 25°C	MEASURE WITH	IF NOT?
1	<b>Output Power</b> Press <i>PTT Channel x</i>	5 watts <sup>1</sup> +10%, -20%	Service monitor set to read power	Check T96HRSS maximum power output setting: must be set to 255 (means 5W) Refer to factory tech support.
2	<b>Frequency Error</b> Press <i>PTT Channel x</i>	±300 Hz	Service monitor set to read frequency error	Open the unit (see 3.4.4) Adjust the Frequency Adjust control on the TCXO <sup>2</sup>
3	<b>Deviation</b> Press <i>PTT Channel x</i>	±4.0 kHz <sup>3</sup> +5%, -10%	Service monitor set to read deviation with mid (15 - 30 kHz) IF filter.	Using T96HRSS, adjust TX deviation with the up/down arrows.
4	Set the service monitor to generate a -80 dBm signal on the selected receive frequency. The signal should be modulated with a 1.0 kHz tone.			
5	<b>Demodulated Audio</b> <ul style="list-style-type: none"> <li>For 9600 b/s set generator deviation to ±2.5 kHz.</li> <li>For 1200 - 4800 b/s set generator deviation to ±4.0 kHz.</li> </ul>	2.0 ±0.2 Vpp	Oscilloscope connected to pin 4 of the data I/O connector. <sup>4</sup>	Using T96HRSS, adjust receive audio level with the up/down arrows.
6	<b>12 dB SINAD</b> Set deviation to ±3 kHz. Set IF filter to mid (15-30 kHz), no audio filter.	≤ 0.5 μV <sup>5</sup>	Service monitor set for SINAD. Connect to pin 4 of the data I/O connector <sup>4</sup> .	Refer to factory technical support.
7	<b>Distortion</b> Set deviation to ±3 kHz. Set IF filter to mid (15-30 kHz), no audio filter.	< 3%	Service monitor set for Distortion. Connect to pin 4 of the data I/O connector <sup>4</sup> .	Refer to factory technical support.

<sup>1</sup> (unless you have set a lower value). Note that readings less than 5 watts may be due to losses in the cables used for testing. Check also your wattmeter frequency calibration curve. Do not be too ready to condemn the transmitter.

<sup>2</sup> The TCXO adjustment is accessible through the hole next to the DIP switch on the logic board.

<sup>3</sup> The unit is automatically set to 19200 b/s (Bt.3) for this procedure. If the unit is later used at 9600 b/s (Bt.5) or 4800 b/s, the deviation will be automatically set to ±3.0 kHz and ±4.0kHz respectively.

<sup>4</sup> Pin 4 is accessible by removing the cable connector hood. If you anticipate frequent need for access to this pin, solder a short insulated lead to that pin on the cable connector and replace the hood. (The same signal is available at TP1 on the logic board if the unit is open).

<sup>5</sup> If a psophometrically weighted filter is available on the service monitor, use 0.35 μV.

Table 6: Tests and Adjustments **half channel** units (12.5 kHz & 15 KHz models)

STEP	ACTION	EXPECTED RESULTS at 25°C	MEASURE WITH	IF NOT?
1	<b>Output Power</b> Press <i>PTT Channel x</i>	5 watts <sup>1</sup> +10%, -20%	Service monitor set to read power	Check T96RSS maximum power output setting: must be set to 255 (means 5W) Refer to factory tech support.
2	<b>Frequency Error</b> Press <i>PTT Channel x</i>	±300 Hz	Service monitor set to read frequency error	Open the unit (see 3.4.4) Adjust the Frequency Adjust control on the TCXO <sup>2</sup>
3	<b>Deviation</b> Press <i>PTT Channel x</i>	±3.0 kHz <sup>3</sup> +5%, -10%	Service monitor set to read deviation with mid (15 - 30 kHz) IF filter.	Using T96HRSS, adjust TX deviation with the up/down arrows.
4	Set the service monitor to generate a -80 dBm signal on the selected receive frequency. The signal should be modulated with a 1.0 kHz tone.			
5	<b>Demodulated Audio</b> For 1200 - 4800 b/s set generator deviation to ±2.0 kHz.	2.0 ±0.2 Vpp	Oscilloscope connected to pin 4 of the data I/O connector. <sup>4</sup>	Using T96HRSS, adjust receive audio level with the up/down arrows.
6	<b>12 dB SINAD</b> Set deviation to 1.5kHz. Set IF filter to mid (15-30 kHz), no audio filter.	≤ 0.5 μV <sup>5</sup>	Service monitor set for SINAD. Connect to pin 4 of the data I/O connector <sup>4</sup> .	Refer to factory technical support.
7	<b>Distortion</b> Set deviation to 1.5kHz. Set IF filter to mid (15-30 kHz), no audio filter.	< 3%	Service monitor set for Distortion. Connect to pin 4 of the data I/O connector <sup>4</sup> .	Refer to factory technical support.

<sup>1</sup> (unless you have set a lower value). Note that readings less than 5 watts may be due to losses in the cables used for testing. Check also your wattmeter frequency calibration curve. Do not be too ready to condemn the transmitter.

<sup>2</sup> The TCXO adjustment is accessible through the hole next to the DIP switch on the logic board.

<sup>3</sup> The unit is automatically set to 9600 b/s (Bt.3) for this procedure. **This T96H model has not been designed to operate at 19200 b/s using half channel radios.** If the unit is later used at 4800 b/s (Bt.5), the deviation will be automatically set to ±2.0 kHz.

<sup>4</sup> Pin 4 is accessible by removing the cable connector hood. If you anticipate frequent need for access to this pin, solder a short insulated lead to that pin on the cable connector and replace the hood. (The same signal is available at TP1 on the logic board if the unit is open).

<sup>5</sup> If a psophometrically weighted filter is available on the service monitor, use 0.35 μV.

### 3.4.4 Opening the Unit

1. Remove the two retaining nuts from the data I/O connector, and the nut and washer from the antenna connector.
2. Remove the four screws holding the rear panel heat sink.
3. Slide the unit out of the case from the rear.

### 3.4.5 Location of Adjustments and Test Points

#### 3.4.5.1 All Models, Logic PCB

Adjustments and test points are shown below.

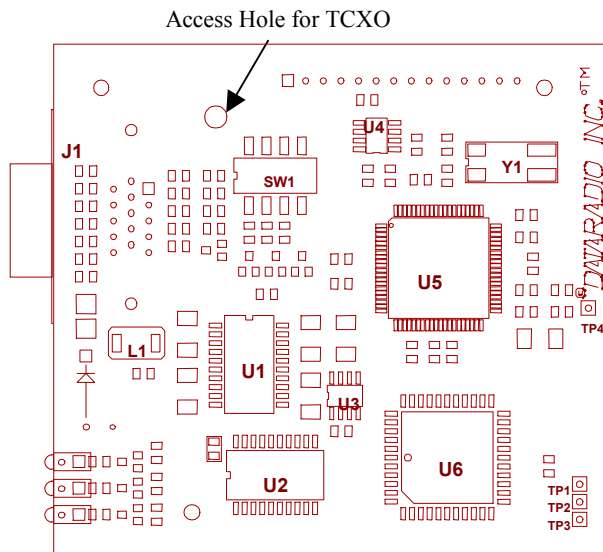

Figure 7 - Logic Board Adjustments and Test Points

## 4. Loader/Modem Board Circuit Description

### 4.1 GENERAL

The Loader/Modem board, Part No. 03280-xxx, is a plug-in circuit board. The four main functions of the Loader/Modem board include, loading the radio synthesizer, providing the baseband modulating signal for the transmitter and demodulating receive audio signals. The Loader/Modem board is programmed by a personal computer and software. The Loader/Modem board connects to the radio through 14-pin connector P1/J201. User data, programming channels and other operating parameters are provided through a DE-15 connector. A block diagram of the

modem is shown at the end of this section.

### 4.2 TRANSMIT DATA

Transmit Data from the RS-232 port is level-shifted to TTL by U1, then gated through U6 and converted from asynchronous to synchronous format by U2. The CPLD modem, U6 takes the digital data stream and synthesizes to the constant-amplitude analog baseband signal, which is filtered by U12, buffered by U10B then applied to radio module TXA at P1-6.

The modem IC is a CPLD based on a Philips eXtended Programmable Logic Array (XPLA, PZ5128) which, with a programmable Raise-Cosine filter

(U12), operates in DRCMSK<sup>1</sup> mode at 4800, 9600 and 19200 bits/sec. It incorporates a 7-bit hardware scrambler and uses Differential (NRZI) encoding in DRCMSK mode to minimize data pattern-sensitivity. Electronic potentiometer U9B (E-Pot), controlled by CPU U5, is used to set the transmitter deviation by amplitude adjustment of the baseband signal.

### 4.3 RECEIVE DATA

Received signals are applied to the RXA pin on P1-13 and amplified by U7A, whose gain is set by the electronic potentiometer U9A, then filtered by U12. The same filter circuit is used for transmission and reception: two analog multiplexer/demultiplexer gates (U11 A and B) controlled by TX\_EN line are used for sharing. The filter U12 cut-off frequency is programmable by the CPU, based on the data rate. The analog signal is then fed to Peak Detectors U7C and U7D, to the slicer circuit U8C via U7B and U8B. The resulting synchronous bit stream is converted to asynchronous at U2 and shifted to RS-232 levels by U1.

### 4.4 SYNTHESIZER PROGRAMMING

The CPU programs the RF module synthesizer serially on each Tx/Rx transition. Logic of U1 and U11A/B switch the receive and transmit data path from the modem to the radio and/or the external serial port, under CPU control. The CPU also controls the sync/async con-

verter U2, the filter cut-off frequency, the serial port handshake lines, and the LED indicators via Q1-3.

Three channel select inputs, ESD protected by D1,2,3, in parallel with the on-board DIP switches, are read by the CPU to select the active channel. The fourth DIP switch puts the unit in TEST mode, which sends a test, tone (data rate/4).

### 4.5 POWER SUPPLIES

The main DC power (13.3V nom.) coming from J1.5,10 is filtered out for transient and then sent directly to power-up the radio module at P1.2. Voltage Regulator U14 (AVCC) provides 5 V for the receiver RX\_5V and analog modem circuitry, while U13 (DVCC) provides 5V for the CPU and other digital logic.

### 4.6 MISCELLANEOUS FUNCTIONS

U4 generates a power-on reset for the CPU and U3 is a temperature sensor used by the firmware to compensate for variations in RSSI.

The RF module's RSSI output, P1-12, is read by an analog input on the CPU, which implements a squelch threshold in software. Other analog inputs are used to read ambient temperature (used to correct RSSI variations) and various internal voltages (B+\_LVL, AVCC, etc.).

The DTR\_PGM input, J2-10, puts the CPU in programming mode in which the CPU accepts commands and setup data from the Radio Service Software.

---

<sup>1</sup> DRCMSK = Differential Raise Cosine Minimum Shift Keying

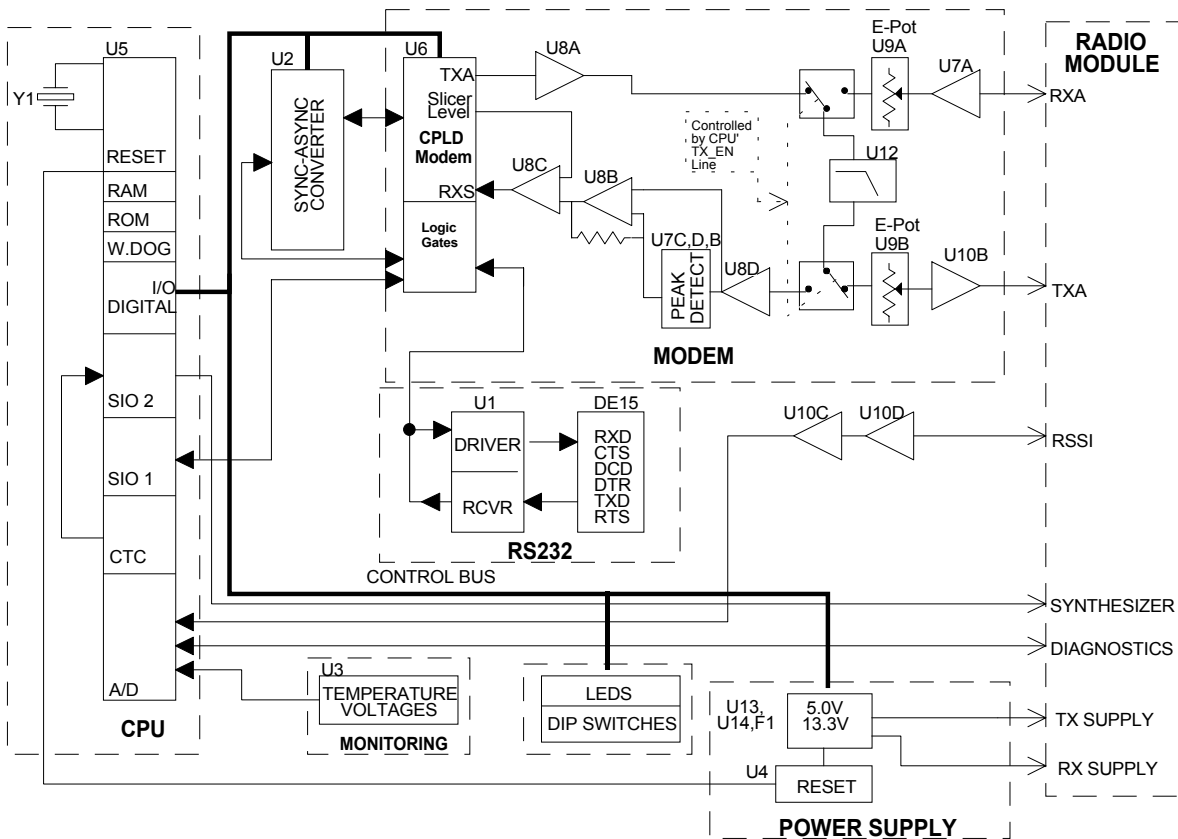

Figure 8 – Logic / Modem board Block Diagram

## 5. Specifications

### GENERAL

	VHF	UHF	900 MHz
Frequency	132 - 174 MHz	403 - 512 MHz	928 - 960 MHz
Channel spacing	15 or 30 kHz	12.5 or 25 kHz	12.5 or 25 kHz
Operating temperature	-30°C to +60°C		
Supply voltage	10 - 16 VDC (applied through the interface connector)		
RX Current at 13.3 VDC	120 mA	125 mA	135 mA
TX Current at 13.3 VDC	1.6 A	1.8 A	2.3 A
RX/TX bandwidth	18 MHz (132 - 150) 24 MHz (150 - 174)	16 MHz except 20 MHz (450 - 470)	32 MHz
Nominal Dimensions	2.25" (H) x 3.25" (W) x 4.75" (L)		
RF connector	SMA-F		
Interface connector	DE-15F high density D-subminiature		

### RECEIVER

	VHF	UHF	900 MHz
Sensitivity (12 dB SINAD)	< 0.35 $\mu$ V *		
Selectivity (25 or 30 kHz)	75 dB typical 70 dB minimum		72 dB typical 65 dB minimum
Selectivity (12.5 or 15 kHz)	65 dB typical 60 dB minimum		63 dB typical 60 dB minimum
Intermodulation	75 dB typical 70 dB minimum		72 dB typical 70 dB minimum
Spurious rejection	75 dB typical 70 dB minimum		75 dB typical 70 dB minimum
FM hum & noise	-48 dB typical * -45 dB max (30 kHz) * -40 dB max (15 kHz) *		-40 dB max (25 kHz)* -35 dB max (12.5 kHz)*
Conducted spurious	< -57 dBm maximum		

\* psophometrically weighted filter

### TRANSMITTER

	VHF	UHF	900 MHz
Power output	1 - 5 watts		
Spurious and harmonics	-63 dBc (-26 dBm) typ -57dBc (-20 dBm) max	-75 dBc (-38 dBm) typ -63dBc (-26 dBm) max	-75 dBc (-38 dBm) typ -57 dBc (-20 dBm) max
Frequency stability	2.5 ppm	1.5 ppm	
FM hum and noise	-50 dB typ (30 kHz) -45 dB max (30 kHz) -40 dB max (15 kHz)	-50 dB typical (25 kHz) -45 dB max 25 kHz) -40 dB max (12.5 kHz)	-50 dB typ (25 kHz) -40 dB max (25 kHz) -35 dB max (12.5 kHz)
Attack time	< 7 ms		
Duty cycle	50% at full power, 30 seconds maximum transmit time		

**MODEM OPERATION**

Interface	EIA RS-232C			
Operation	Simplex/half duplex			
Data rates	4800 b/s	9600 b/s	19200 b/s	
Modulation type	DRCMSK	DRCMSK	DRCMSK	
RTS/CTS delay (Online diagnostics OFF)	30 ms			
Bit error rate	better than $1 \times 10^{-6}$ at 1.0 $\mu$ V at 9600 b/s			
Protocol	Transparent to the user			

**DISPLAY and CONTROLS**

3 status LEDs	RX, TX, PWR
Internal DIP switch	Channel select, test mode

**DIAGNOSTICS**

Online	Supply voltage, internal temperature, forward and reverse power, RSSI
Offline	As for online, plus analog supply voltage, transmit test tones

**PROGRAMMABLE FEATURES**

30 second timeout timer enable, bit rate, word length, parity, compatibility modes, frequency, channel, diagnostics on/off.

**FCC / IC  
CERTIFICATIONS**

	FCC	IC (DOC)
VHF		
UHF		
900 MHz		

## INDEX

<b>A</b>		<b>H</b>	
addressing	3	<b>half channel</b> units	13
adjustments	11	<b>I</b>	
equipment required	11	ID number	3
location of controls	14	<b>L</b>	
maintenance intervals	11	LED indicators	7
<b>B</b>		<b>N</b>	
bit dribble	10	networks	4
<b>C</b>		<b>O</b>	
channel selection	9	operation	9
commands	4	<b>P</b>	
compatibility	10	performance verification	11
configuration	1	<b>R</b>	
<b>D</b>		RS-232 signal description	8
diagnostics	3	RS-232 signal levels	7
offline	4	RTS/CTS timing	10
online	3, 6	<b>S</b>	
<b>E</b>		specifications	17
extended delay	10	<b>T</b>	
extended turnoff	10	T-Base	5
<b>F</b>			
<b>full channel</b> units	12		