

DATARADIO COR Ltd.
Corporate Headquarters and Manufacturing Operations
299 Johnson Avenue, Suite 110
Waseca, MN 56093-0833 USA
Phone: 507-833-8819
Fax: 507-833-6748

FCC Part 80/90 Certification Application

FCC Form 731

For The

**Viper 200
VHF RADIO MODEM**

FCC ID: NP4-5028-502

For a Class II Permissive Change

TABLE OF CONTENTS

	Page #
Test 6: Transmitter Occupied Bandwidth – Mask D	3
6.25 kHz Quarter Channel Mask E / Mask B	6
12.5 kHz Half Channel Mask D / Mask B	13
25 kHz Full Channel Mask C / Mask B	20
50 kHz Full Channel Mask C / Mask B	27
6.25 / 12.5 kHz / 25 / 50 kHz Mask F	40
Calibration Information	62

NAME OF TEST: Transmitter Occupied Bandwidth

RULE PART NUMBER: FCC: 2.201, 2.202, 2.1033 (c)(14), 2.1049 (h), 2.1041;90.203(j)(3); 80.211 (f)
IC: RSS-Gen 4.4.1

Necessary Bandwidth Measurement

This radio modem uses digital modulation signals, passing through a Squared Root Raised Cosine $\alpha=0.2$ or $\alpha=0.5$ DSP implemented low-pass filter to an FM transceiver. The digital modulation is based on SRRC4FSK allows a SRRC2FSK subset to be used for lower bit rate with a better sensitivity reception. The necessary bandwidth calculation for this type of modulation is not covered by paragraphs (1), (2) or (3) from 2.202(c). Therefore, the approach outlined in (2.202(c)(4)) is applicable in this case.

The measurement explanations are provided below.

Necessary Bandwidth Measurement:

Channel Spacing	Emission Type	Data Rate	Baud Rate	Measured Peak Deviation	Measured 99% Occupied BW
6.25 kHz	3K20 F1D	12 kbps	4000	1.15 kHz	3.20 kHz
6.25 kHz	3K45 F1D	16 kbps	4000	1.056 kHz	3.45 kHz
12.5 kHz	8K50 F1D	24 kbps	8000	3.725 kHz	8.50 kHz
12.5 kHz	8K08 F1D	32 kbps	8000	3.728 kHz	8.08 kHz
25 kHz	17K8 F1D	48 kbps	16000	7.590 kHz	17.8 kHz
25 kHz	17K0 F1D	64 kbps	16000	7.520 kHz	17.0 kHz
50 kHz	33K3 F1D	32 kbps	32000	12.31 kHz	33.3 kHz
50 kHz	34K0 F1D	64 kbps	32000	14.45 kHz	34.0 kHz
50 kHz	36K0 F1D	96 kbps	32000	15.33 kHz	36.0 kHz
50 kHz	33K0 F1D	128 kbps	32000	11.66 kHz	33.0 kHz

THEORY OF MEASUREMENT

The way to define the Occupied Bandwidth is “the frequency bandwidth such that, below its lower and above its upper frequency limits, the mean powers radiated are each equal to 0.5 percent of the total mean power radiated by a given emission” (FCC 2.202), the mathematics are as follows:

$$0.005*TP=P_{(f1)}=\int_0^{f1} PSD_{(f)}df$$

$$0.995*TP=P_{(f2)}=\int_0^{f2} PSD_{(f)}df$$

$$OBW=f2-f1$$

where TP (total mean power) is

$$TP=\int_0^{+\infty} PSD_{(f)}df=(1/t)\int_{-\infty}^{+\infty}|z_{(t)}|^2dt$$

and PSD (power spectral distribution) is

$$PSD_{(f)}=|Z_{(f)}|^2+|Z_{(-f)}|^2 \quad 0\leq f<\infty$$

and expresses the positive frequency representation of the transmitter output power for $z(t)$ signal.

By applying these mathematics to the measurements, it is possible to measure the Occupied Bandwidth using a digital spectrum analyzer.

The Occupied Bandwidth measurement is in two parts relatively independent of each other. The first gives the RF spectrum profile, and the second calculates the frequency limits and they result in the Occupied bandwidth. While the first involves RF measurement instrumentation, the second is strictly a computational part related to measured trace.

TEST EQUIPMENT:

50-Ohm Attenuator, Bird Electronics Model 50-A-FFN-20 (20dB, 50W)
 50-Ohm Attenuator, Bird Electronics Model 10-A-MFN-10 (10dB, 10W)
 DC Power Supply, Hewlett Packard Model 6653A
 Spectrum Analyzer, Hewlett Packard Model HP8563E
 Modulation Analyzer, Hewlett Packard Model HP8901B

TEST SET-UP:

For the above requirements, the occupied bandwidth of a transmitter was measured using an HP8563E using the following settings:

Occupied BW % Power: 99%

Trace: Max Hold A

RBW: 100 Hz (6.25 and 12.5 kHz channels)

RBW: 300 Hz (25 kHz and 50 kHz channels)

VBW: 3 kHz

SPAN: 100 kHz (6.25 and 12.5 kHz channels)

SPAN: 150 kHz (25 kHz channels)

SPAN: 200 kHz (50 kHz channels)

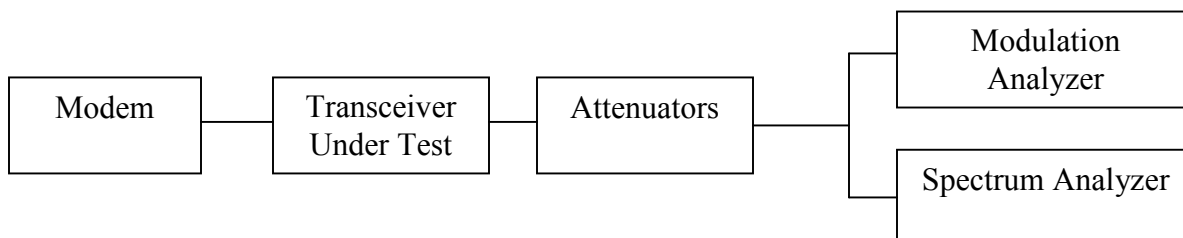

MODULATION SOURCE DESCRIPTION:

The 4-level signaling transmits two information bits per symbol (baud), which yields a bit rate of twice the on-air baud rate. Hence the 64 kbps references in the Installation Guide correspond to a transmitter baud rate of 32000 baud. The 8-level signaling transmits three information bits per symbol (baud), which yields a bit rate of three times the on-air baud rate. Hence the 12, 24, 48, or 96 kbps references in the Installation Guide correspond to a transmitter baud rate of 4000, 8000, 16000 or 32000 baud. The 16-level signaling transmits four information bits per symbol (baud), which yields a bit rate of four times the on-air baud rate. Hence the 16, 32, 64, or 128 kbps references in the Installation Guide correspond to a transmitter baud rate of 4000, 8000, 16000 or 32000baud. That digital signal is digitally filtered (Square Root Raised Cosine pulse shaping with $\alpha=0.2$ or 0.5) by the DSP and converted to I&Q components, then fed to the digital to analog converter. This SRRC4FSK, SRRC8FSK, or SRRC16FSK wave shape applied to the FM modulator will then produce a compact RF spectrum, when using proper frequency deviation, to fit inside the restrictive masks inherent to the intended channel bandwidth.

TX Data Test Pattern:

The transmit “test data” pattern command produces a 107,3741,823 bit pseudo- random pattern. This pattern is generated by the DSP. The 107,3741,823 bit sequence is repeated thereafter as long is necessary to complete the test duration, this sequence lasts 67,109 seconds at 16 kbps. Commonly this is longer than the test duration. This pattern is applied to the DSP modulator for mapping to 4-FSK, 8-FSK and 16-FSK and pulse shaping with SRRC $\alpha=0.2$ or $\alpha=0.5$ depending on the channel selection. This data follows same modulation process as described in MODULATION SOURCE DESCRIPTION and the resulting base band signal feeds the modulator's input of the transceiver.

NAME OF TEST: Transmitter Occupied Bandwidth for Emission Designators
3K20F1D and **3K45F1D**

RULE PART NUMBER: FCC: 2.202, 90.209 (b)(5), 90.210(e), 2.1049 (c) (1); 80.211 (f)
 IC: RSS-119 5.8.4
 Note: All data taken at 12 watts is to be applied to Part 80 only. Data taken at 2 watts is to be applied to Part 90 (217-220 MHz).

MINIMUM STANDARDS: **Mask E**
 Sidebands and Spurious [Rule 90.210 (e), 5.8.4, P = 12 Watts, P=2 Watts and P=1 Watt]
 Authorized Bandwidth = 6 kHz [Rule 90.209(b) (5), 5.8.4]
 From Fo to 3 kHz, down 0 dB.
 Greater than 3 kHz to 4.6 kHz, down 30 +16.67(fd-3 kHz) dB or 55 +10 log(P) or 65 dB, whichever is the lesser attenuation.
 Greater than 12.5 kHz, at least 50+10log₁₀(P) or 70 dB, whichever is the lesser attenuation.

Attenuation = 0 dB at Fo to 3 kHz
 Attenuation = 30 dB at 3 kHz and 56.7 dB at 4.6 kHz @ 12 Watts
 Attenuation = 65 dB at frequencies greater than 4.6 kHz @ 12 Watts
 Attenuation = 30 dB at 3 kHz and 56.7 dB at 4.6 kHz @ 2 Watts
 Attenuation = 60 dB at frequencies greater than 4.6 kHz @ 2 Watts
 Attenuation = 30 dB at 3 kHz and 50 dB at 4.2 kHz and 55 dB at 4.6 kHz @ 1 Watt
 Attenuation = 55 dB at frequencies greater than 4.6 kHz @ 1 Watt

TEST RESULTS: Meets minimum standards (see data on following page)

TEST CONDITIONS: Standard Test Conditions, 25 C
 RF Power Level = 1 Watt, 2 Watts and 12 Watts
 Voltage = 20VDC

TEST PROCEDURE: TIA/EIA – 603-C, 2.2.13, 3.2.11.2

TEST EQUIPMENT: 50-Ohm Attenuator, Bird Electronics Model 50-A-FFN-20 (20dB, 50W)
 50-Ohm Attenuator, Bird Electronics Model 10-A-MFN-10 (10dB, 10W)
 50-Ohm Attenuator, Pasternack Model PE7002-10 (10dB)
 DC Power Supply, Hewlett Packard Model 6653A
 Spectrum Analyzer, Hewlett Packard Model HP8563E
 Modulation Analyzer, Hewlett Packard Model HP8901B

TEST SET-UP:

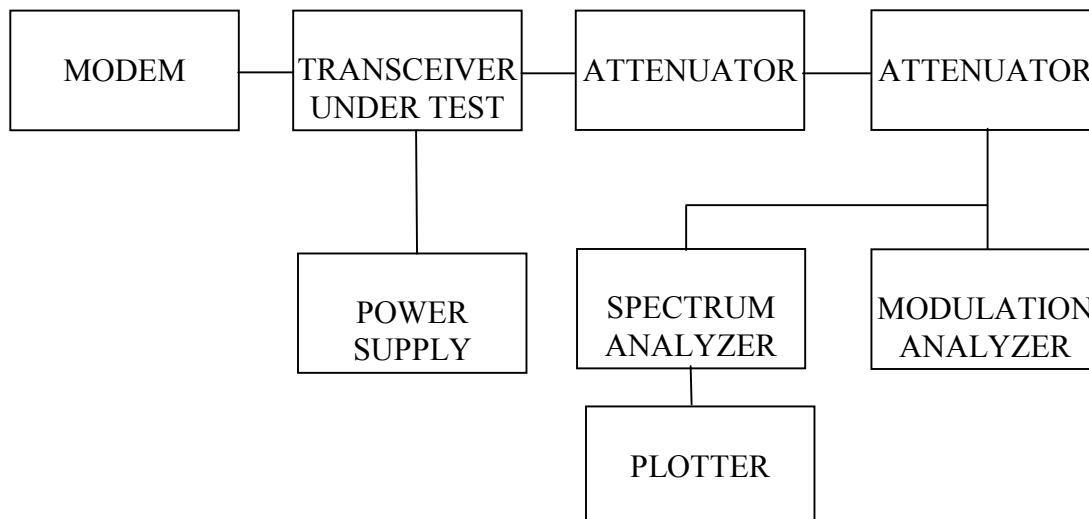

Mask: E, 1W
Output Power = 1 Watt

Spectrum for Emission: 3K20 F1D
Data Rate: 12 kbps Peak Deviation with Data: 1.15kHz

Mask B = Black Line
Mask E = Green Line

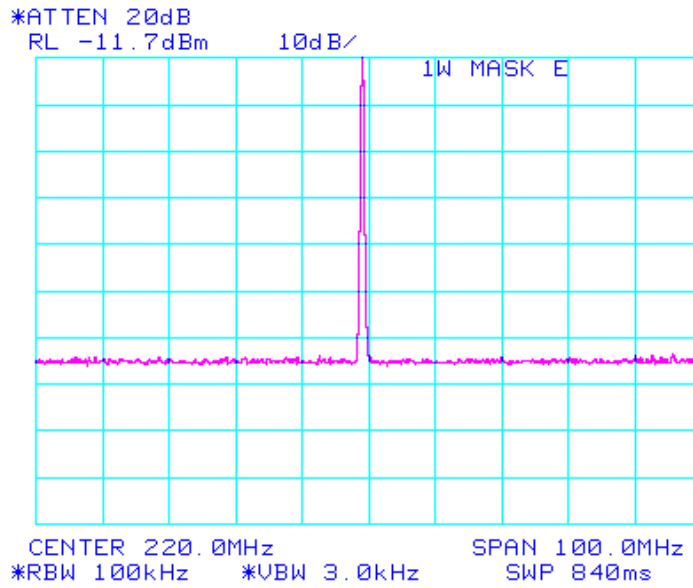
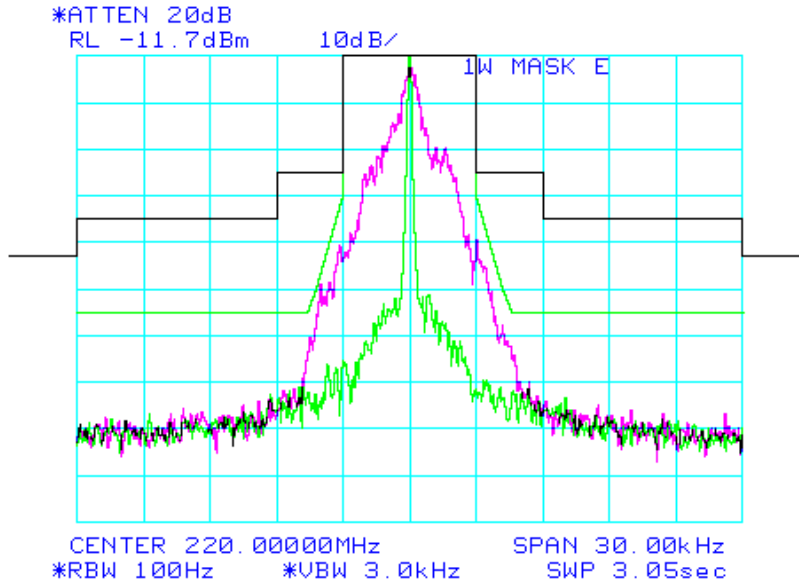

Output Power = 2 Watt
Applicable to Part 90 (217-220 MHz)

Mask B = Black Line
Mask E = Green Line

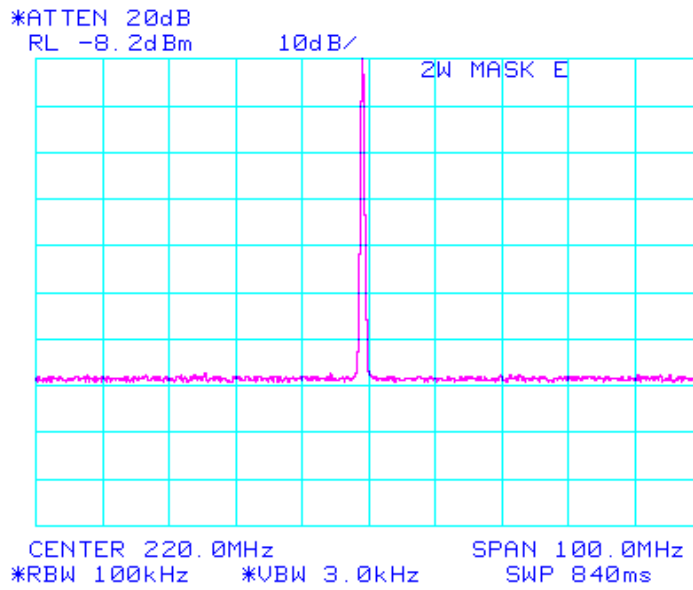
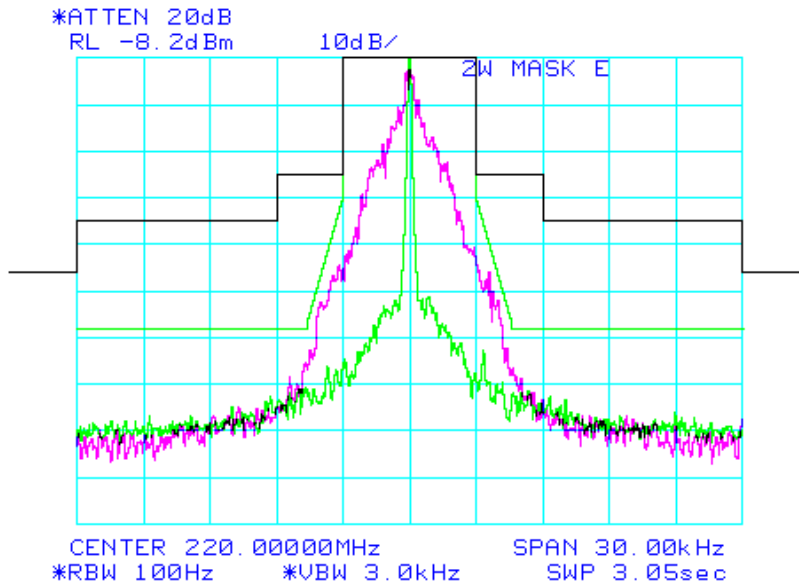

Output Power = 12 Watt
Applicable to Part 80 (216-220 MHz) only

Mask B = Black Line
Mask E = Green Line

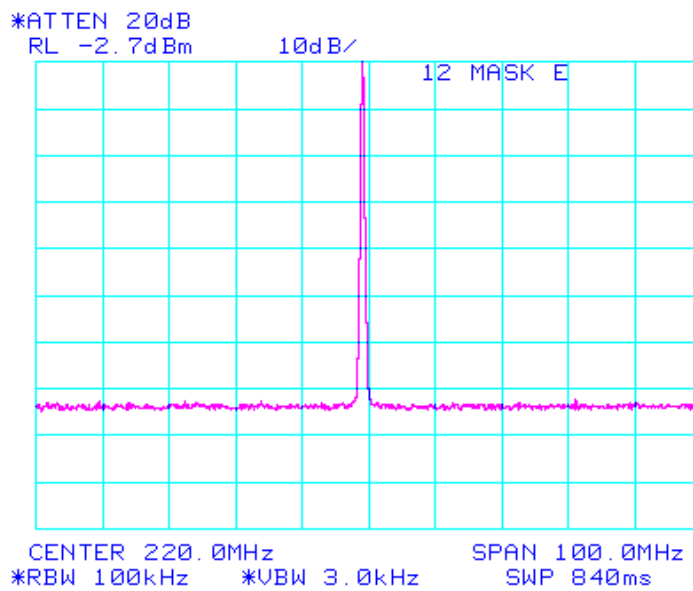
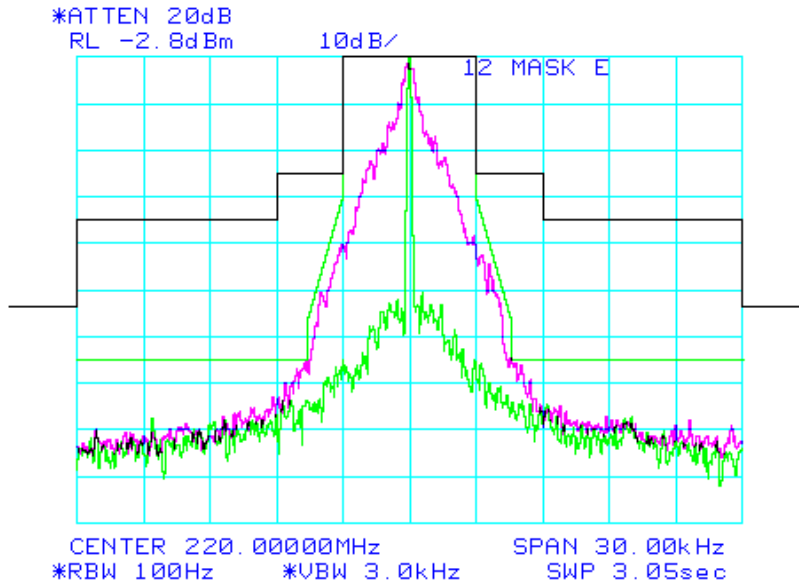

Mask: E, 1W
Output Power = 1 Watt

Spectrum for Emission: 3K45 F1D
Data Rate: 16 kbps Peak Deviation with Data: 1.056 kHz

Mask B = Black Line
Mask E = Green Line

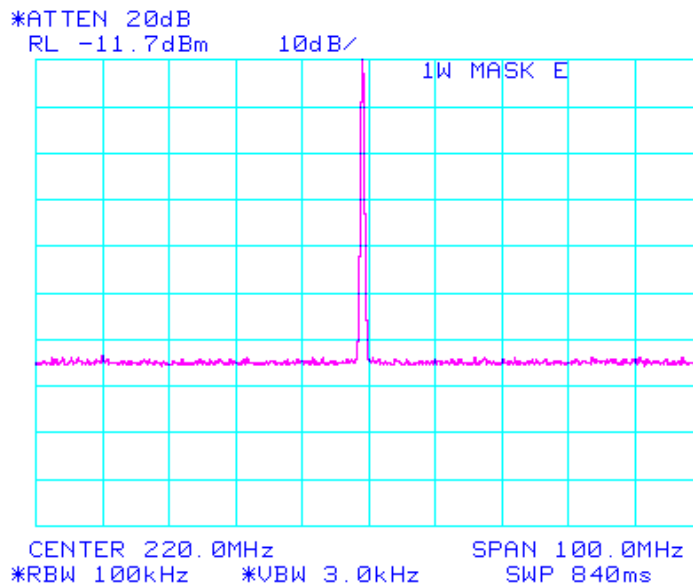
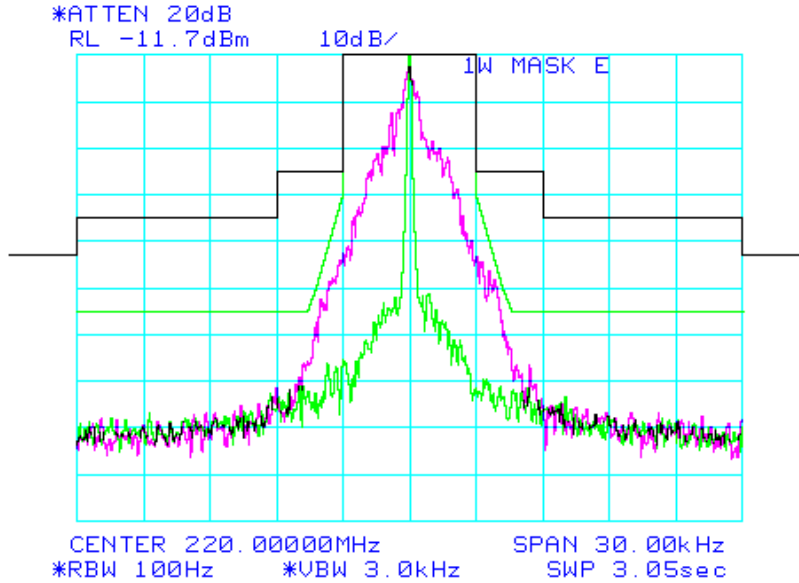

Output Power = 2 Watt
Applicable to Part 90 (217-220 MHz)

Mask B = Black Line
Mask E = Green Line

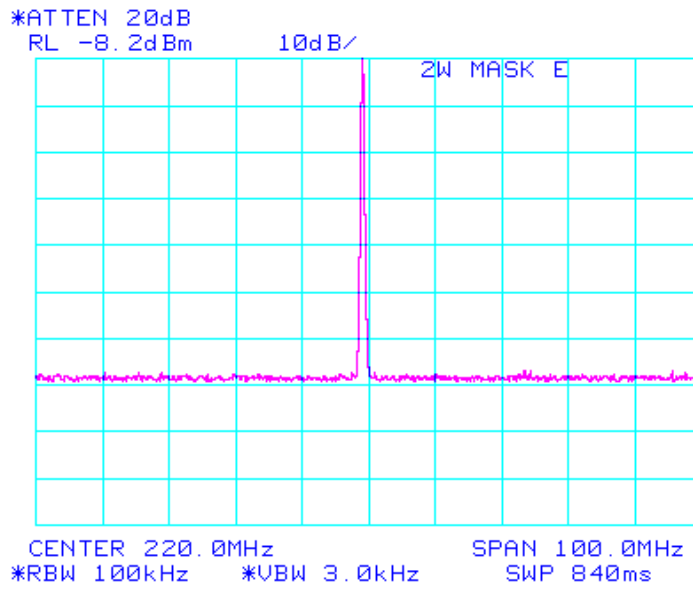
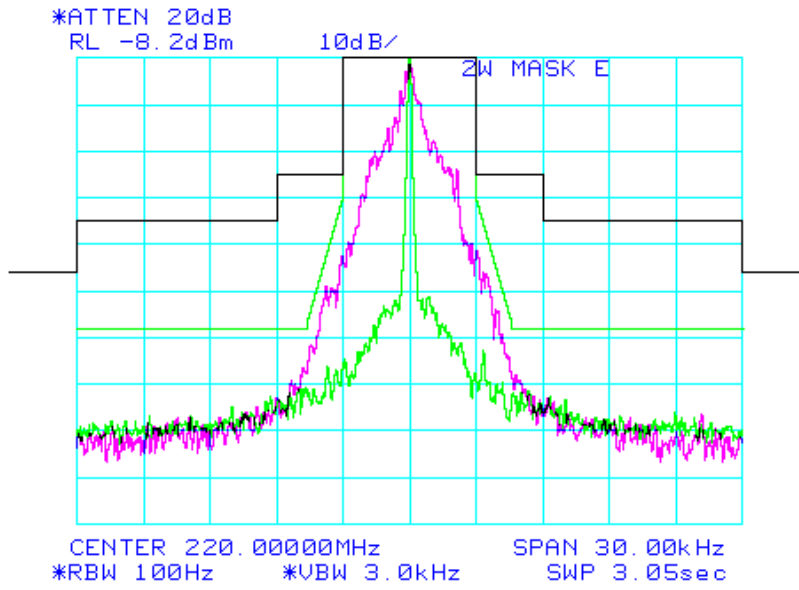

Output Power = 12 Watt
Applicable to Part 80 (216-220 MHz) only

Mask B = Black Line
Mask E = Green Line

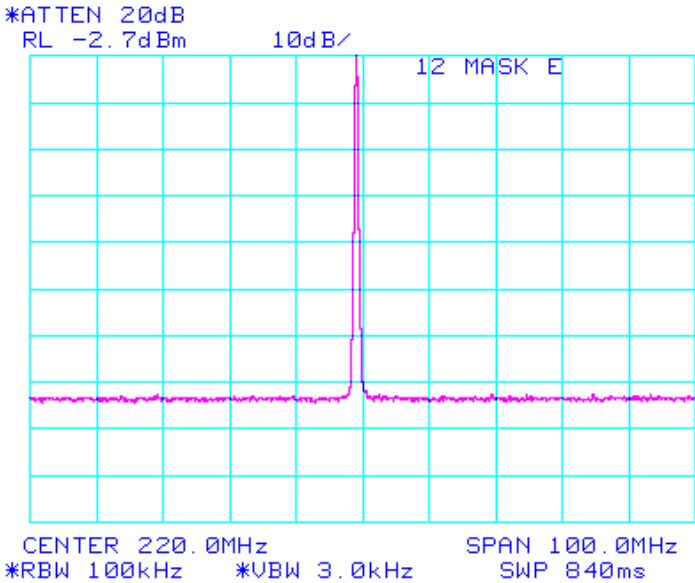
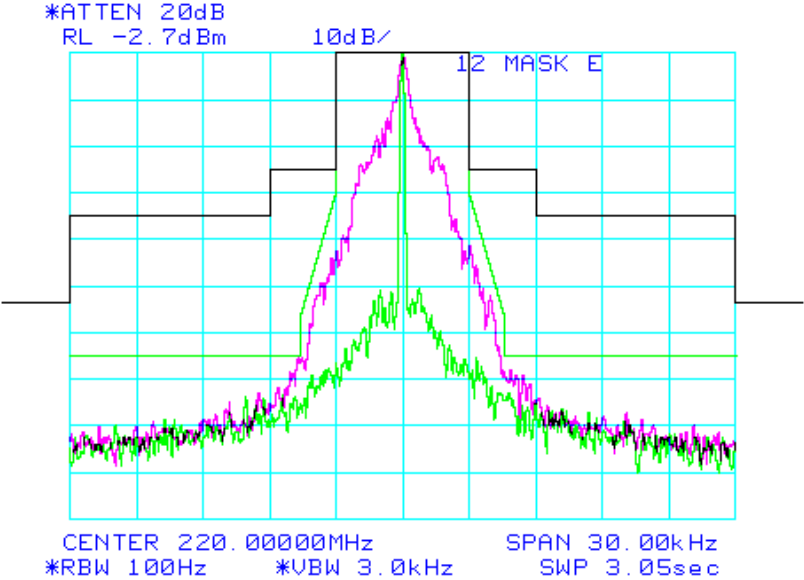

NAME OF TEST: Transmitter Occupied Bandwidth for Emission Designators
8K50F1D and **8K08F1D**

RULE PART NUMBER: FCC: 2.202, 90.209 (b)(5), 90.210(d), 2.1049 (c) (1); 80.211 (f)
IC: RSS-119 5.8.3
Note: All data taken at 12 watts is to be applied to Part 80 only. Data taken at 2 watts is to be applied to Part 90 (217-220 MHz).

MINIMUM STANDARDS: **Mask D**
Sidebands and Spurious [Rule 90.210 (d), 5.8.3, P = 12 Watts, P = 2 Watts and P = 1 Watt]
Authorized Bandwidth = 11.25 kHz [Rule 90.209(b) (5), 5.8.3]
From f_o to 5.625 kHz, down 0 dB.
Greater than 5.625 kHz to 12.5 kHz, down $7.27(f_i - 2.88\text{kHz})$ dB.
Greater than 12.5 kHz, at least $50 + 10\log_{10}(P)$ or 70 dB, whichever is the lesser attenuation.

Attenuation = 0 dB at f_o to 5.625 kHz
Attenuation = 20 dB at 5.625 kHz and 70 dB at 12.5 kHz
Attenuation = 60.8 dB at frequencies greater than 12.5 kHz @ 12 W
Attenuation = 53 dB at frequencies greater than 12.5 kHz @ 2 W
Attenuation = 50 dB at frequencies greater than 12.5 kHz @ 1 W

TEST RESULTS: Meets minimum standards (see data on following page)

TEST CONDITIONS: Standard Test Conditions, 25 C
RF Power Level = 1 Watt, 2 Watts and 12 Watts
Voltage = 20VDC

TEST PROCEDURE: TIA/EIA – 603-C, 2.2.13, 3.2.11.2

TEST EQUIPMENT: 50-Ohm Attenuator, Bird Electronics Model 50-A-FFN-20 (20dB, 50W)
50-Ohm Attenuator, Bird Electronics Model 10-A-MFN-10 (10dB, 10W)
50-Ohm Attenuator, Pasternack Model PE7002-10 (10dB)
DC Power Supply, Hewlett Packard Model 6653A
Spectrum Analyzer, Hewlett Packard Model HP8563E
Modulation Analyzer, Hewlett Packard Model HP8901B

TEST SET-UP:

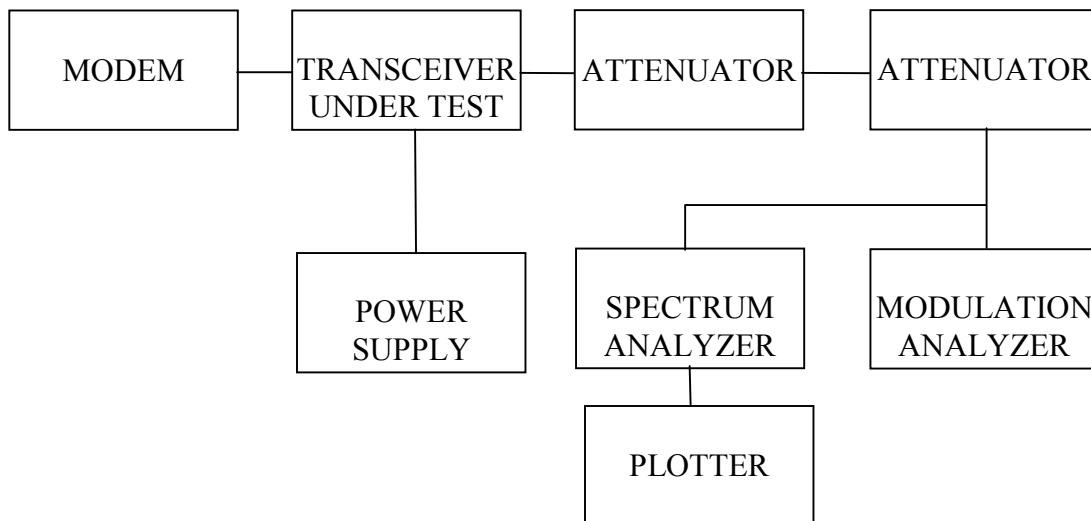

Mask: D, 1W
Output Power = 1 Watt

Spectrum for Emission: 8K50 F1D
Data Rate: 24 kbps Peak Deviation with Data: 3.725 kHz

Mask B = Black Line
Mask D = Green Line

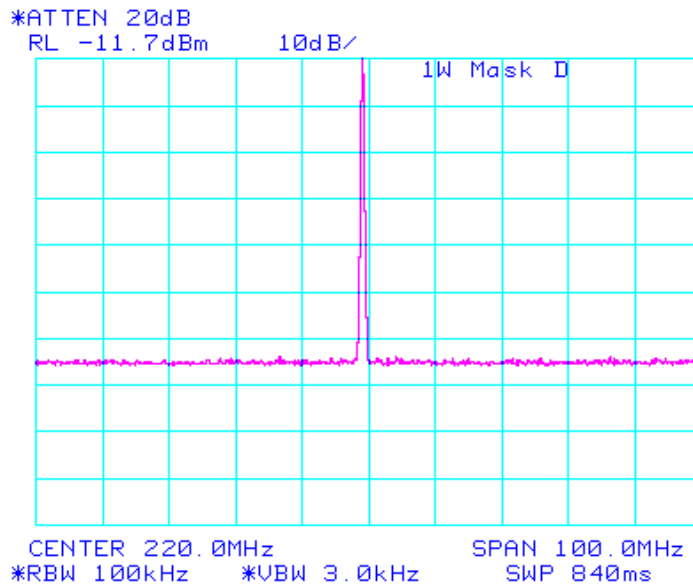
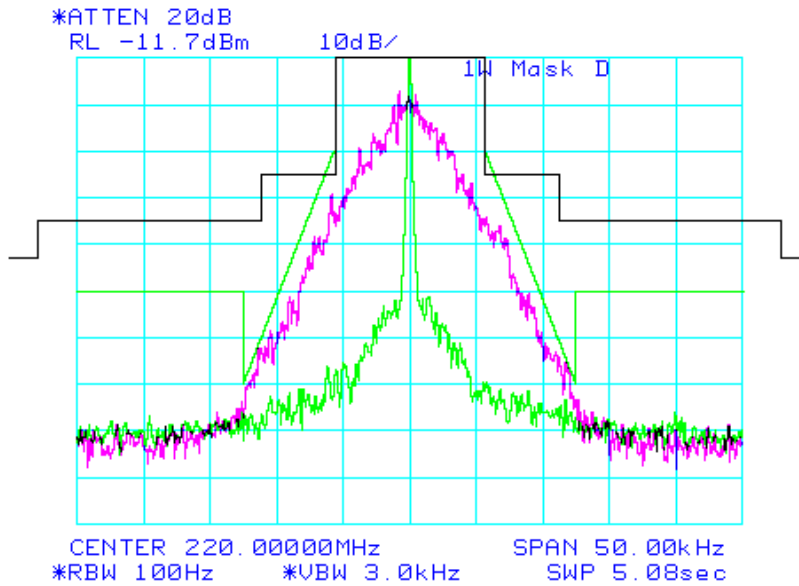

Output Power = 2 Watt
Applicable to Part 90 (217-220 MHz)

Mask B = Black Line
Mask D = Green Line

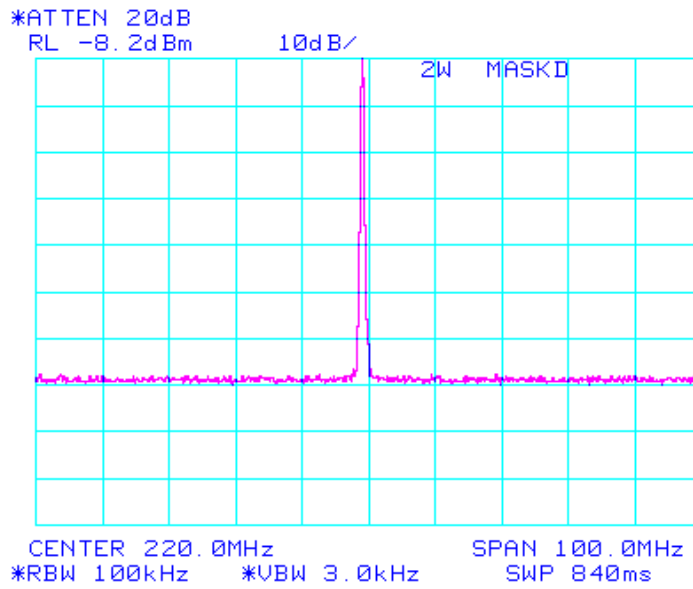
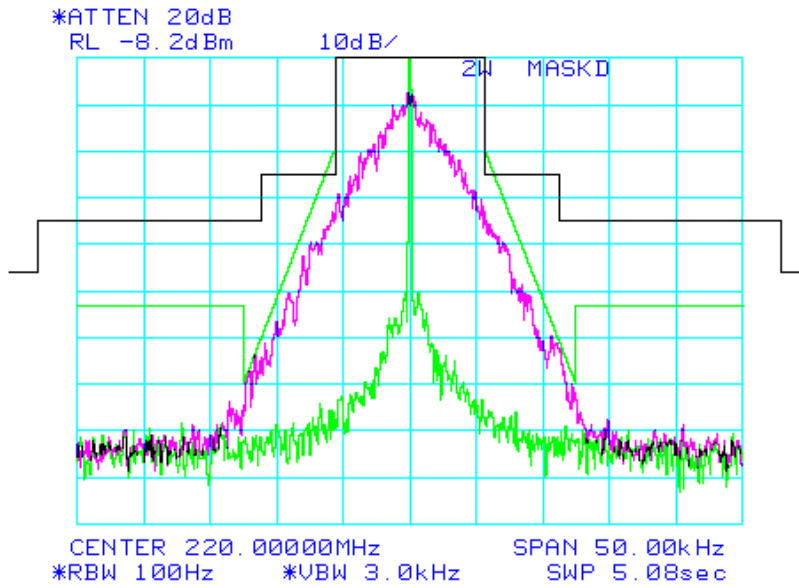

Output Power = 12 Watts
Applicable to Part 80 (216-220 MHz) only

Mask B = Black Line
Mask D = Green Line

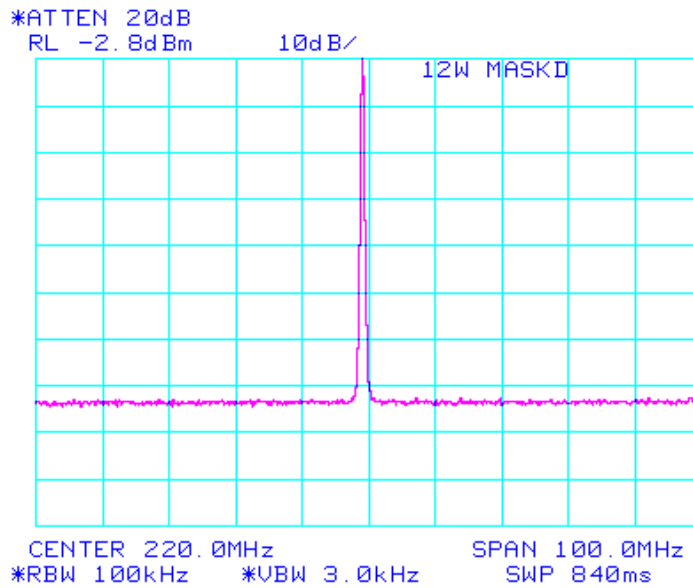
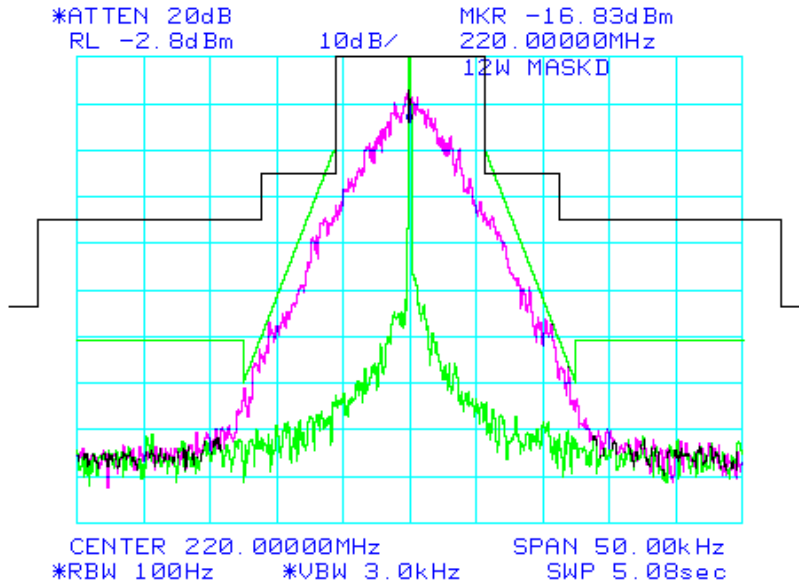

Mask: D, 1W
Output Power = 1 Watt

Spectrum for Emission: 8K08 F1D
Data Rate: 32 kbps Peak Deviation with Data: 3.728 kHz

Mask B = Black Line
Mask D = Green Line

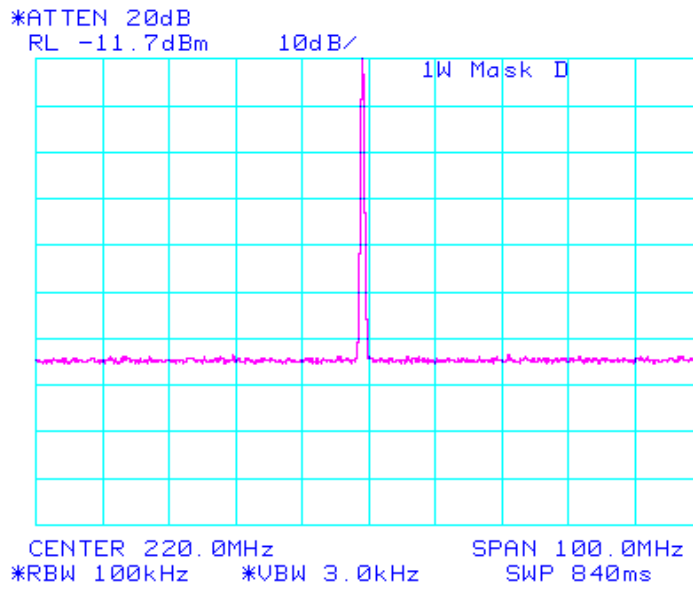
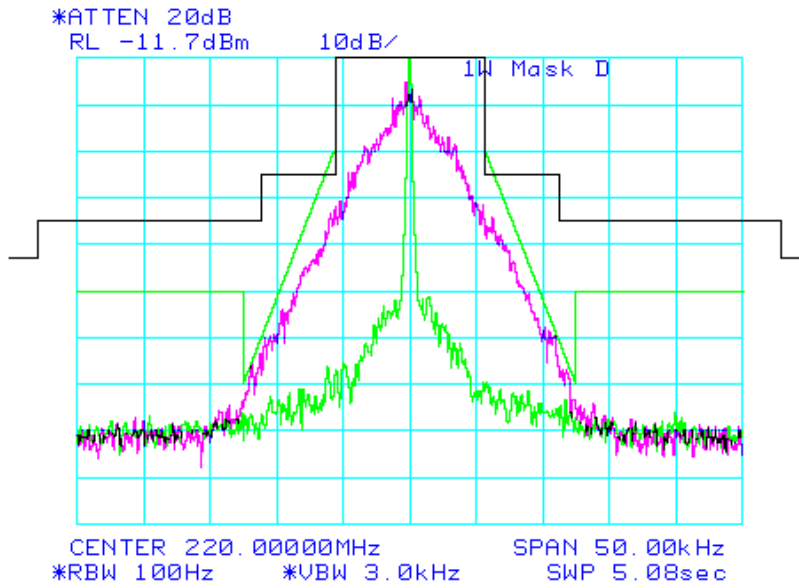

Output Power = 2 Watt
Applicable to Part 90 (217-220 MHz)

Mask B = Black Line
Mask D = Green Line

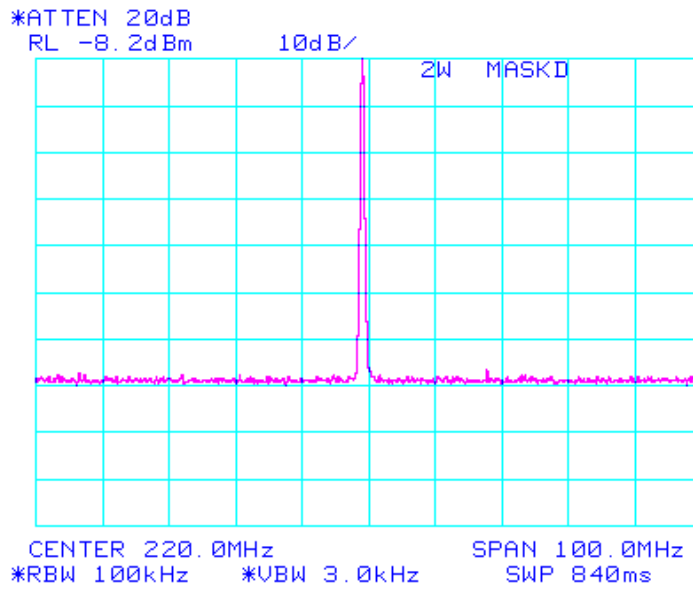
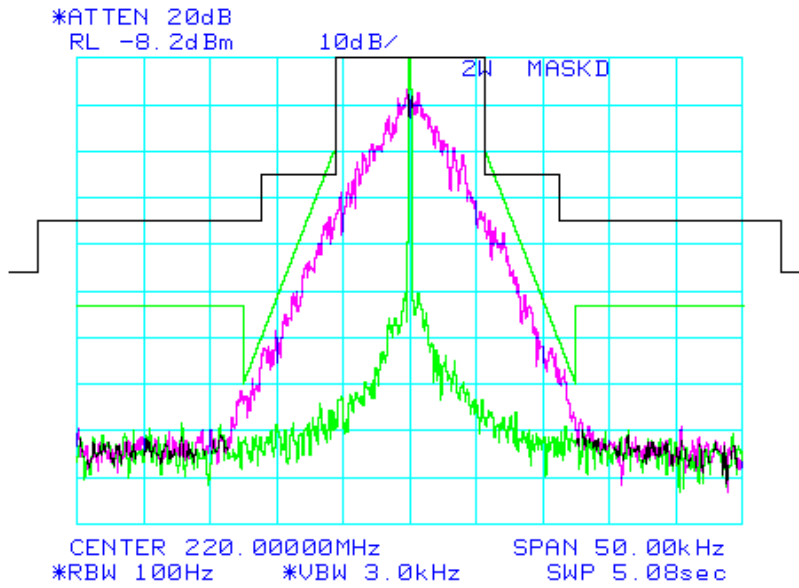

Output Power = 12 Watts
Applicable to Part 80 (216-220 MHz) only

Mask B = Black Line
Mask D = Green Line

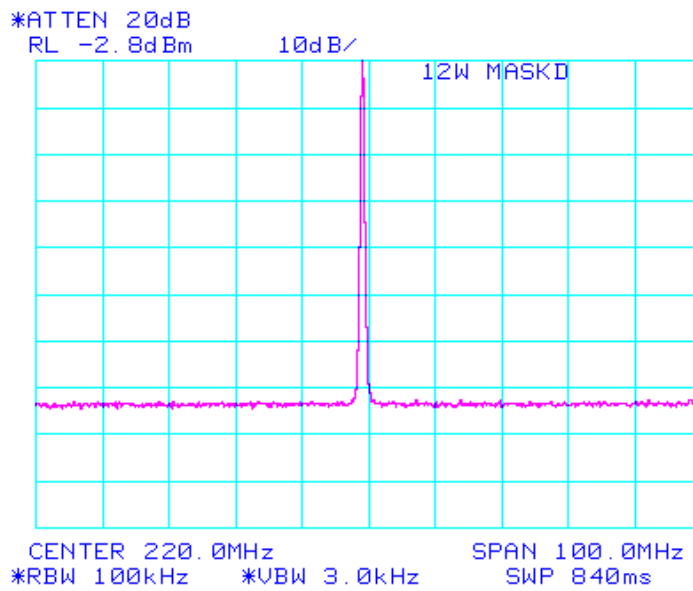
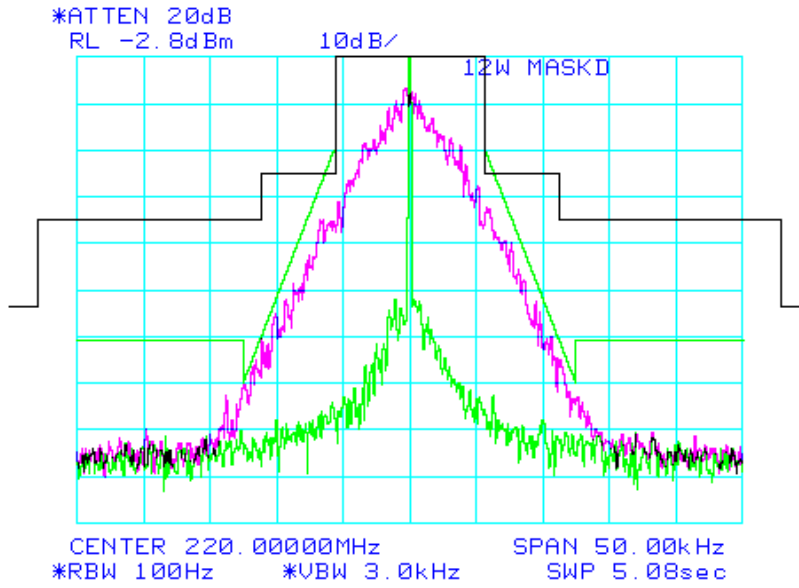

NAME OF TEST: Transmitter Occupied Bandwidth for Emission Designators **17K8F1D** and **17K0F1D**

RULE PART NUMBER: FCC: 2.202, 90.209 (b)(5), 90.210(c), 2.1049 (c) (1); 80.211 (f)
IC: RSS-119 5.8.2
Note: All data taken at 12 watts is to be applied to Part 80 only. Data taken at 2 watts is to be applied to Part 90 (217-220 MHz).

MINIMUM STANDARDS: **Mask C**
Sidebands and Spurious [Rule 90.210 (c), 5.8.2, P = 12 Watts and P=1 Watt]
Authorized Bandwidth = 20 kHz [Rule 90.209(b) (5), 5.8.2]
From Fo to 5 kHz, down 0 dB.
Greater than 5 kHz to 10 kHz, down $83 * \log_{10}(f_d / 5)$ dB.
Greater than 10 kHz to 250% of authorized BW, at least $29 * \log_{10}(f_d^2 / 11)$ or 50 dB, whichever is the lesser attenuation
Greater than 250% of authorized BW, $43 + 10\log_{10}(P)$

Attenuation = 0 dB at Fo to 5 kHz
Attenuation = 25 dB at 10 kHz
Attenuation = 50 dB at 24.1 kHz
Attenuation = 50 dB at 50 kHz
Attenuation = 53.8 dB at frequencies greater than 50 kHz @ 12 W
Attenuation = 46 dB at frequencies greater than 50 kHz @ 2 W
Attenuation = 43 dB at frequencies greater than 50 kHz @ 1 W

TEST RESULTS: Meets minimum standards (see data on following page)

TEST CONDITIONS: Standard Test Conditions, 25 C
RF Power Level = 1 Watt, 2 Watts and 12 Watts
Voltage = 20VDC

TEST PROCEDURE: TIA/EIA – 603-C, 2.2.13, 3.2.11.2

TEST EQUIPMENT: 50-Ohm Attenuator, Bird Electronics Model 50-A-FFN-20 (20dB, 50W)
50-Ohm Attenuator, Bird Electronics Model 10-A-MFN-10 (10dB, 10W)
50-Ohm Attenuator, Pasternack Model PE7002-10 (10dB)
DC Power Supply, Hewlett Packard Model 6653A
Spectrum Analyzer, Hewlett Packard Model HP8563E
Modulation Analyzer, Hewlett Packard Model HP8901B

TEST SET-UP:

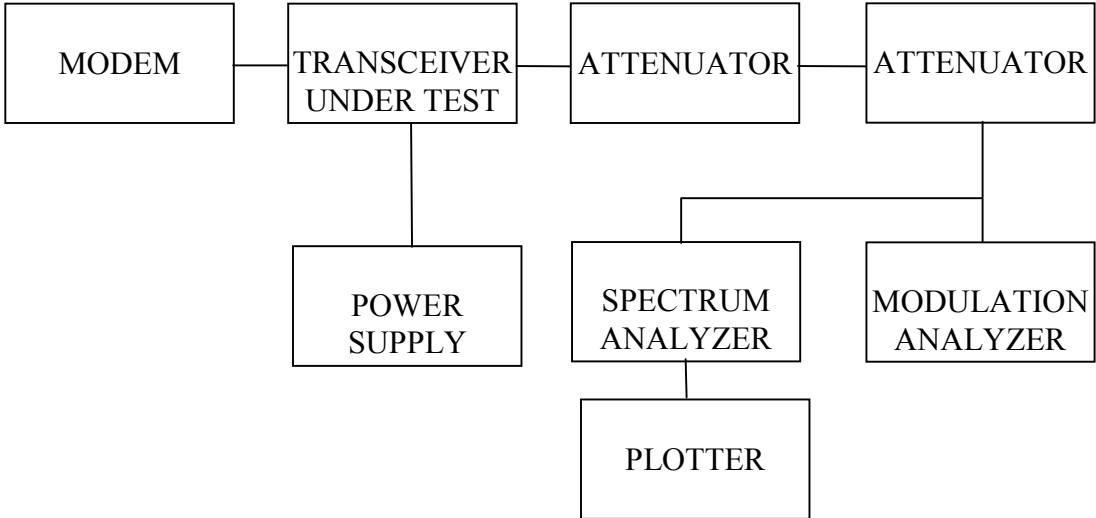

Mask: C, 1W
Output Power = 1 Watt

Spectrum for Emission: 17K8 F1D
Data Rate: 48 kbps Peak Deviation with Data: 7.59 kHz

Mask B = Black Line
Mask C = Green Line

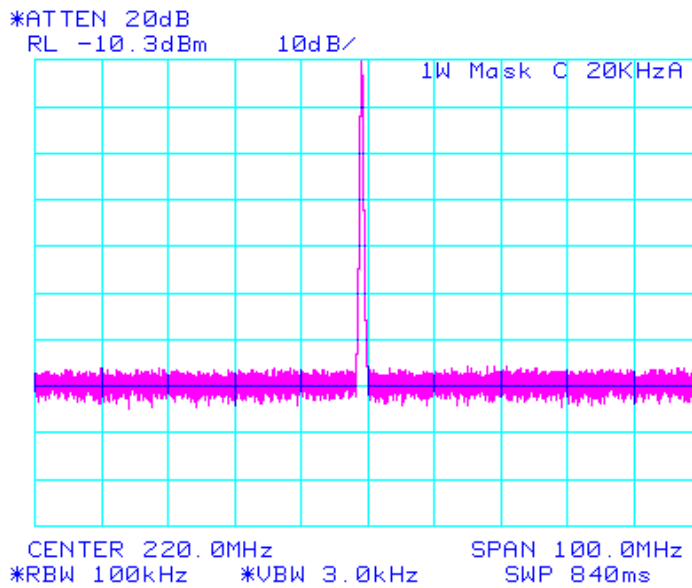
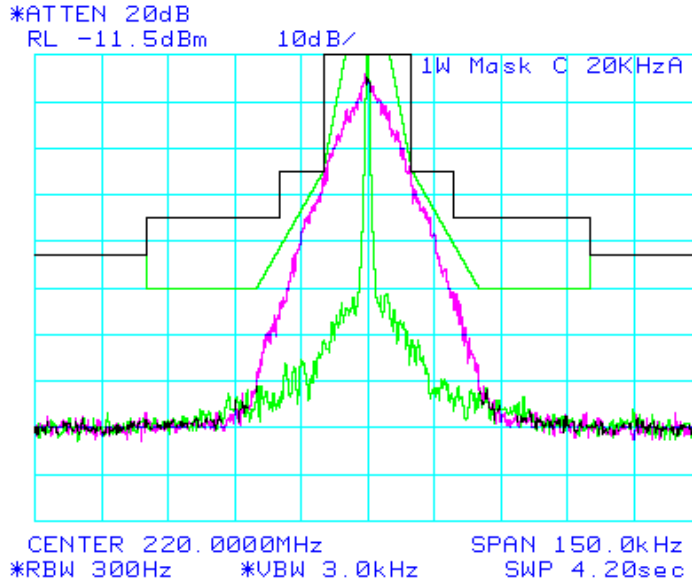

Output Power = 2 Watt
Applicable to Part 90 (217-220 MHz)

Mask B = Black Line
Mask C = Green Line

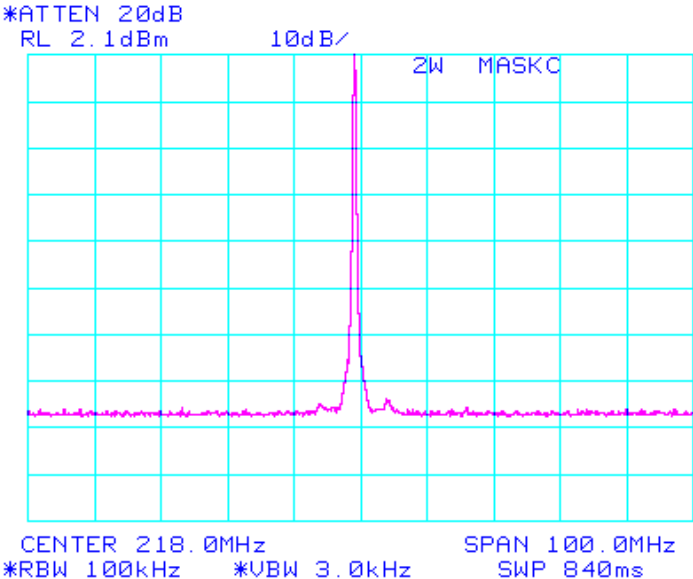
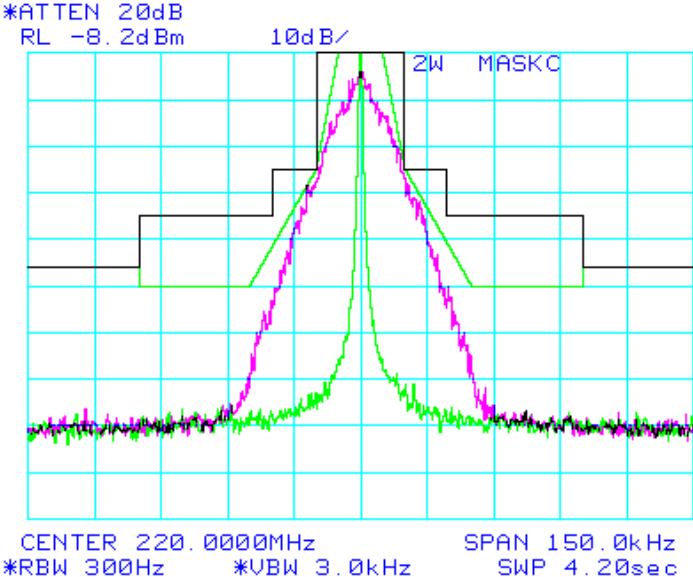

Output Power = 12 Watt
Applicable to Part 80 (216-220 MHz) only

Mask B = Black Line
Mask C = Green Line

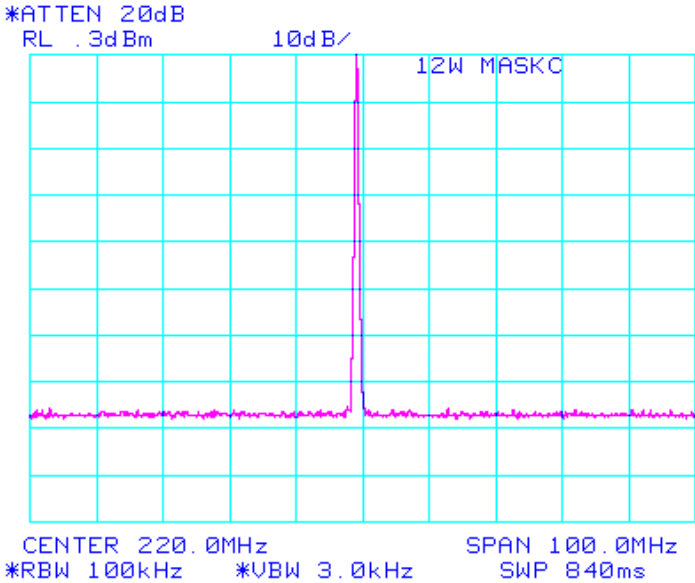
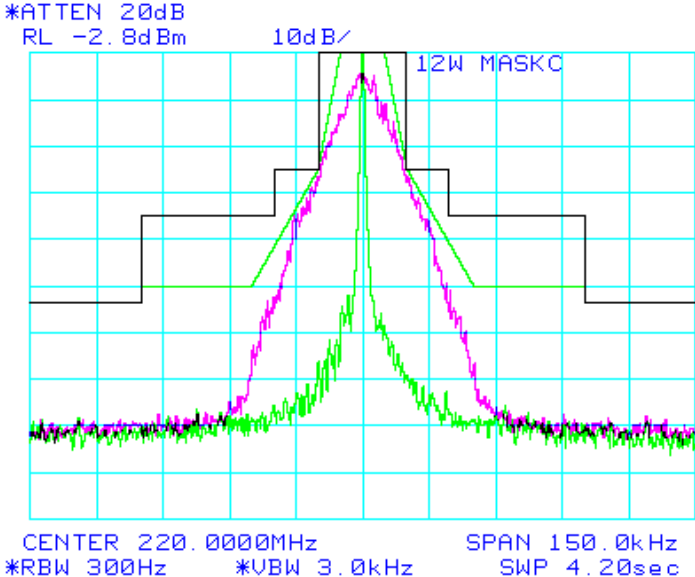

Output Power = 2 Watt
Applicable to Part 90 (217-220 MHz)\

Mask B = Black Line
Mask C = Green Line

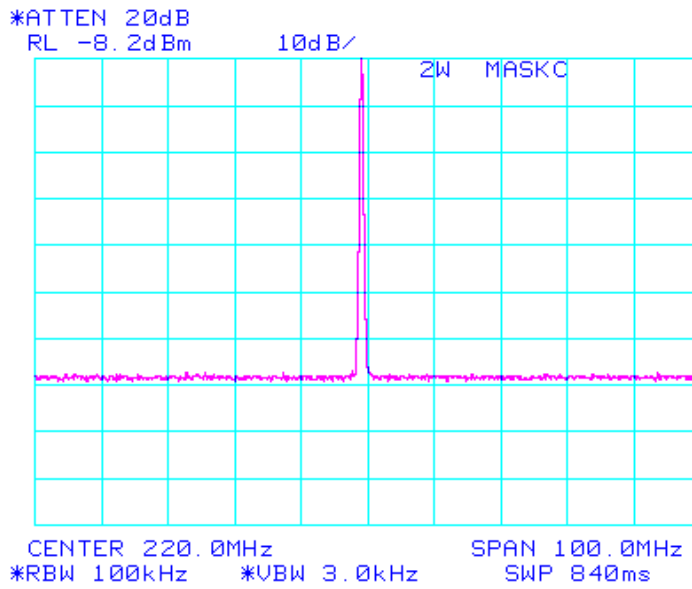
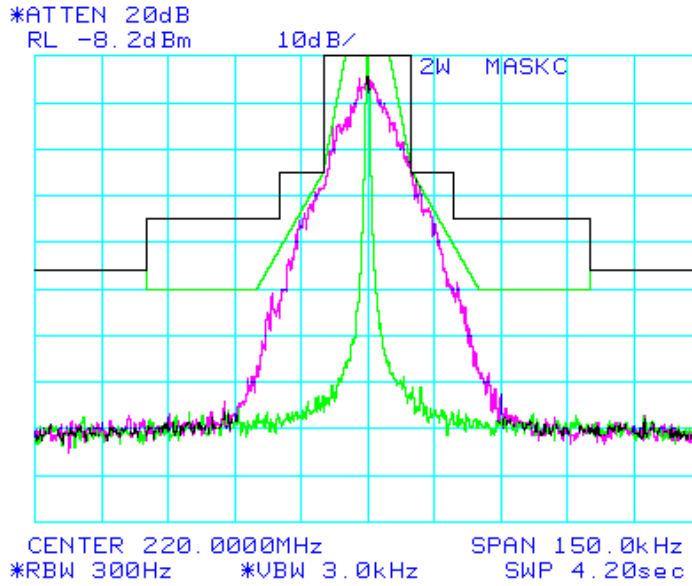

Output Power = 12 Watts
Applicable to Part 80 (216-220 MHz) only

Mask B = Black Line
Mask C = Green Line

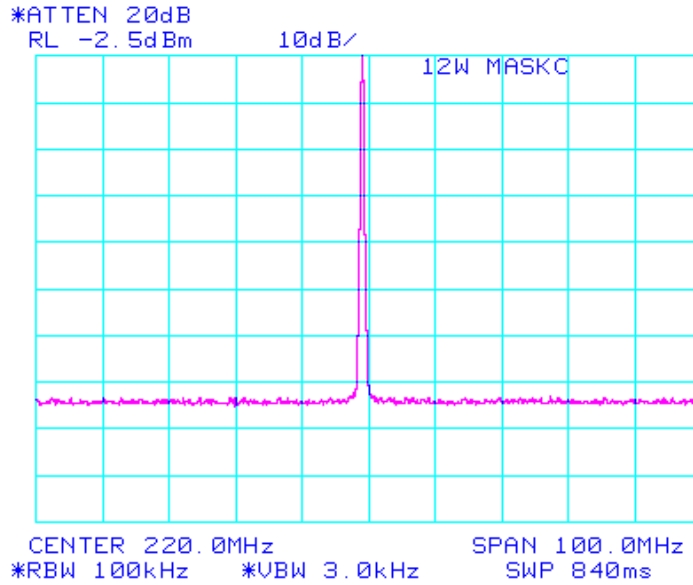
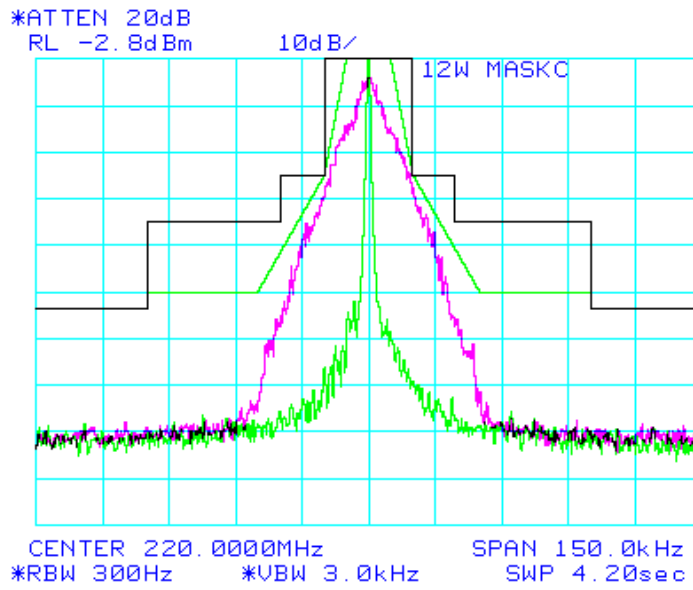

NAME OF TEST: Transmitter Occupied Bandwidth for Emission Designators **33K3F1D, 34K0F1D, 36K0F1D** and **33K0F1D**

RULE PART NUMBER: FCC: 2.202, 90.209 (b)(5), 90.210(c), 90.259 (7), 2.1049 (c) (1);
80.211 (f), 80.481
IC: RSS-119 5.8.2
Note: All data taken at 12 watts is to be applied to Part 80 only. Data taken at 2 watts is to be applied to Part 90 (217-220 MHz).

MINIMUM STANDARDS: **Mask C 50kHz**
Sidebands and Spurious [Rule 90.210 (c), 5.8.2, P = 12 Watts and P=1 Watt]
Authorized Bandwidth = 40 kHz [Rule 90.209(b) (5), 5.8.2; 90.259, 80.481]
From Fo to 5 kHz, down 0 dB.
Greater than 5 kHz to 10 kHz, down $83 * \log_{10}(f_d / 5)$ dB.
Greater than 10 kHz to 250% of authorized BW, at least $29 * \log_{10}(f_d^2 / 11)$ or 50 dB, whichever is the lesser attenuation
Greater than 250% of authorized BW, $43 + 10\log_{10}(P)$

Attenuation = 0 dB at Fo to 17.5 kHz
Attenuation = 25 dB at 22.5 kHz
Attenuation = 50 dB at 37.5 kHz
Attenuation = 50 dB at 62.5 kHz
Attenuation = 53.8 dB at frequencies greater than 62.5 kHz @ 12 W
Attenuation = 46 dB at frequencies greater than 62.5 kHz @ 2 W
Attenuation = 43 dB at frequencies greater than 62.5 kHz @ 1 W

TEST RESULTS: Meets minimum standards (see data on following page)

TEST CONDITIONS: Standard Test Conditions, 25 C
RF Power Level = 1 Watt, 2 Watts and 12 Watts
Voltage = 20VDC

TEST PROCEDURE: TIA/EIA – 603-C, 2.2.13, 3.2.11.2

TEST EQUIPMENT: 50-Ohm Attenuator, Bird Electronics Model 50-A-FFN-20 (20dB, 50W)
50-Ohm Attenuator, Bird Electronics Model 10-A-MFN-10 (10dB, 10W)
50-Ohm Attenuator, Pasternack Model PE7002-10 (10dB)
DC Power Supply, Hewlett Packard Model 6653A
Spectrum Analyzer, Hewlett Packard Model HP8563E
Modulation Analyzer, Hewlett Packard Model HP8901B

TEST SET-UP:

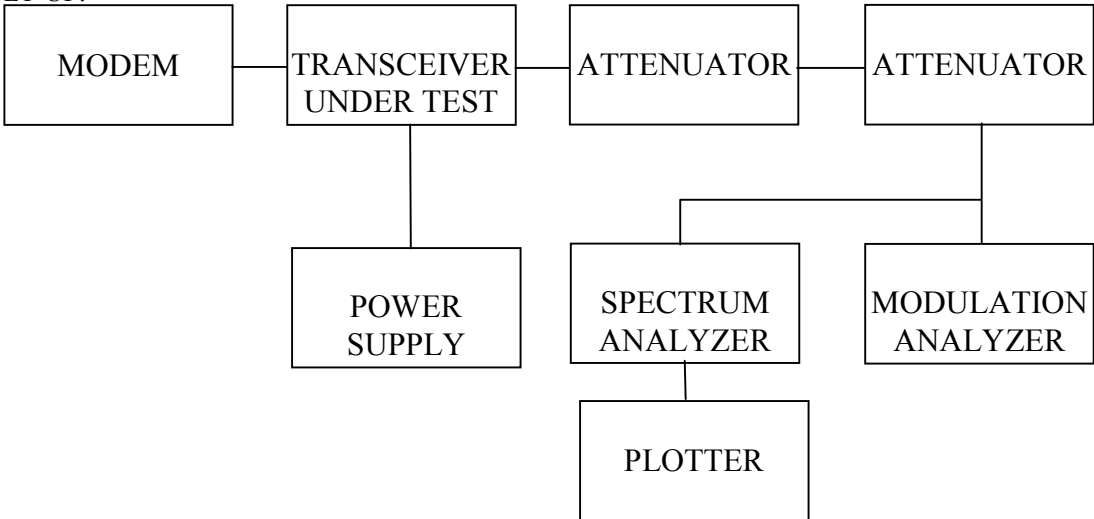

Mask: C 50 kHz
Output Power = 1 Watt

Spectrum for Emission: 33K3 F1D
Data Rate: 32 kbps Peak Deviation with Data: 12.31 kHz

Mask B = Black Line
Mask C 50 kHz = Green Line

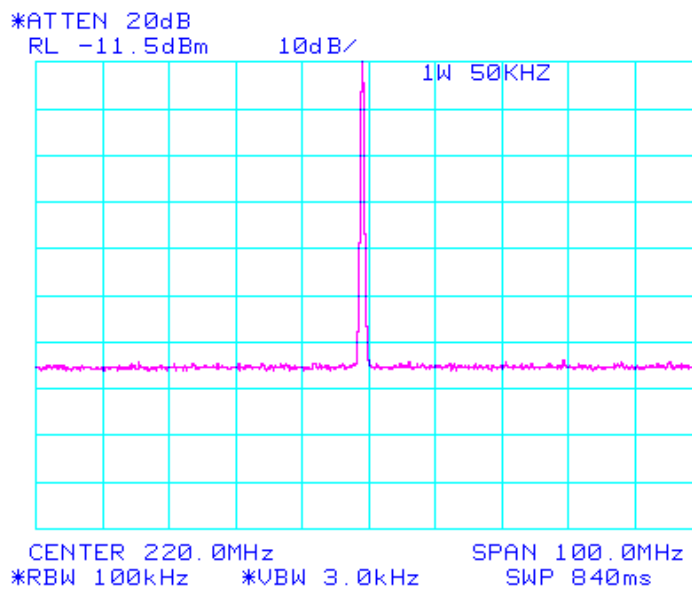
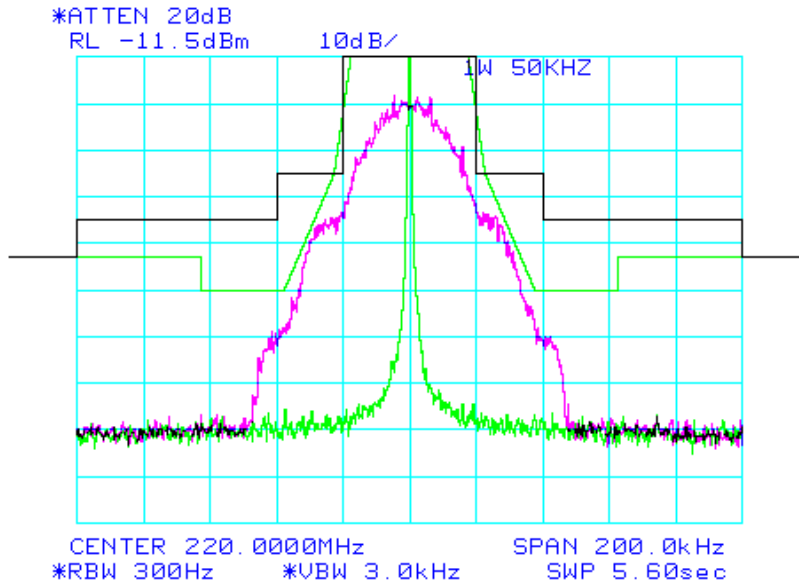

Mask: C 50 kHz Spectrum for Emission: 33K3 F1D
Output Power = 2 Watt Data Rate: 32 kbps Peak Deviation with Data: 12.31 kHz
Applicable to Part 90 (217-220 MHz)

Mask B = Black Line
Mask C 50 kHz = Green Line

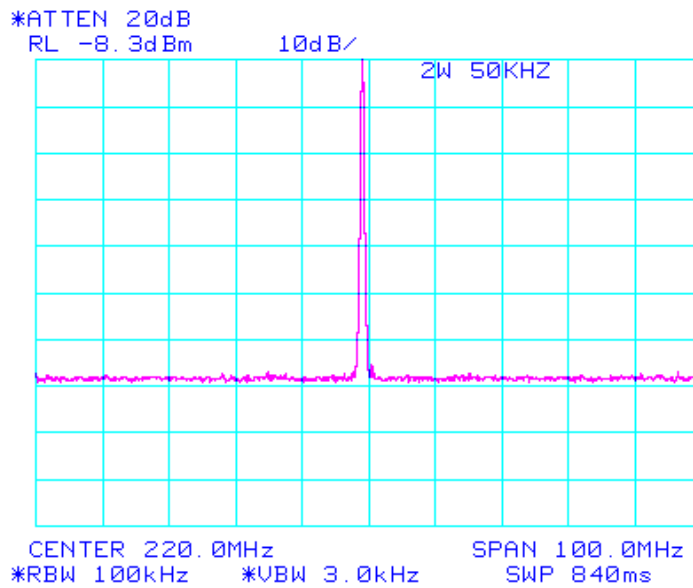
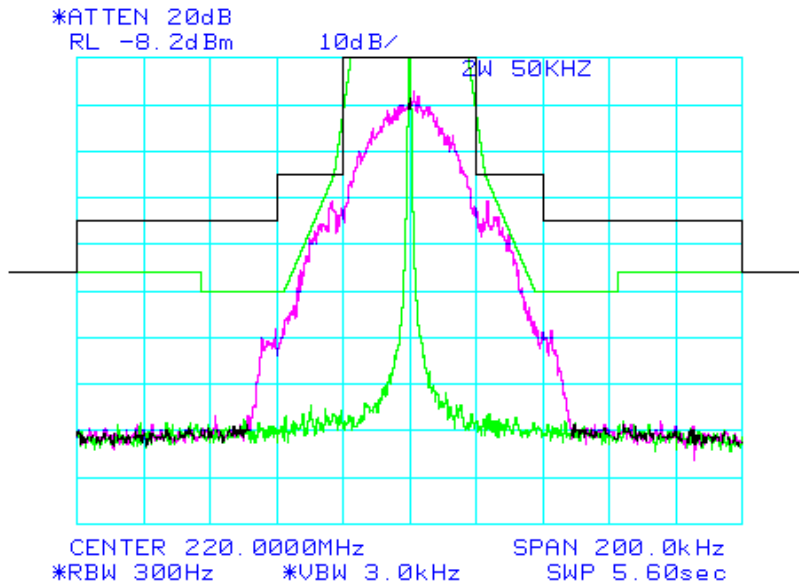

Mask: C 50 kHz Spectrum for Emission: 33K3 F1D
Output Power = 12 Watt Data Rate: 32 kbps Peak Deviation with Data: 12.31 kHz
Applicable to Part 80 (216-220 MHz) only

Mask B = Black Line
Mask C 50 kHz = Green Line

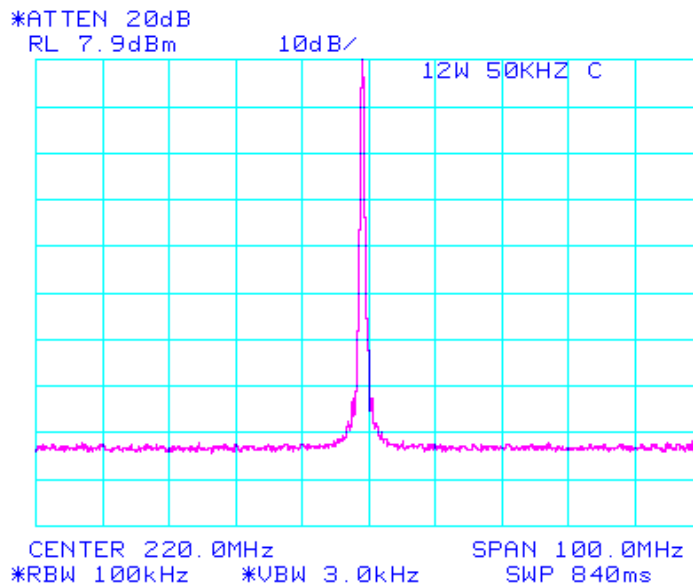
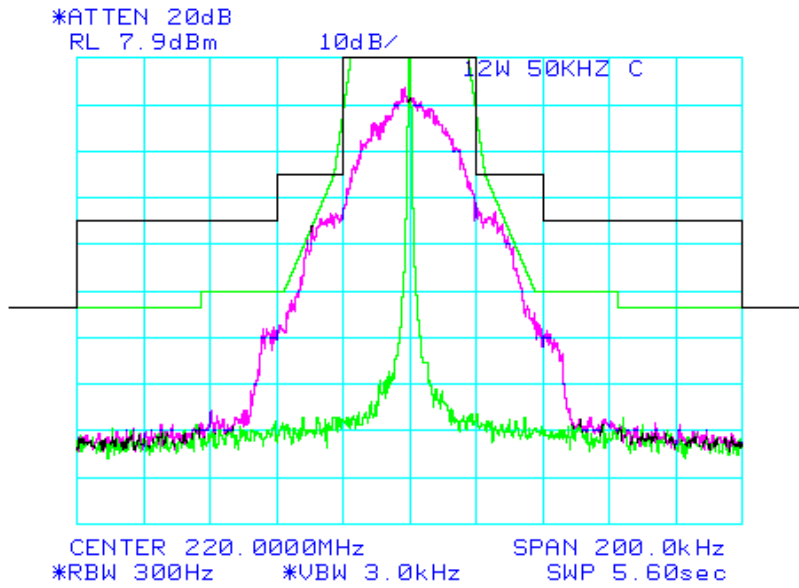

Mask: C 50 kHz
Output Power = 1 Watt

Spectrum for Emission: 34K0 F1D
Data Rate: 64 kbps Peak Deviation with Data: 14.45 kHz

Mask B = Black Line
Mask C 50 kHz = Green Line

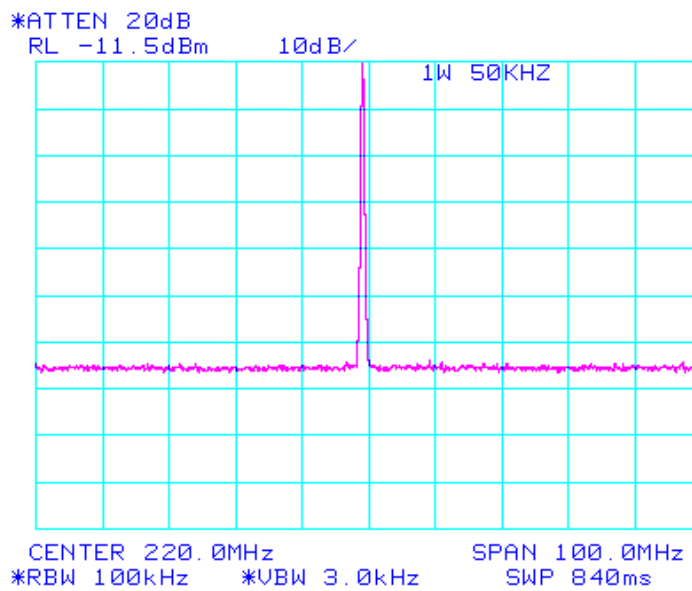
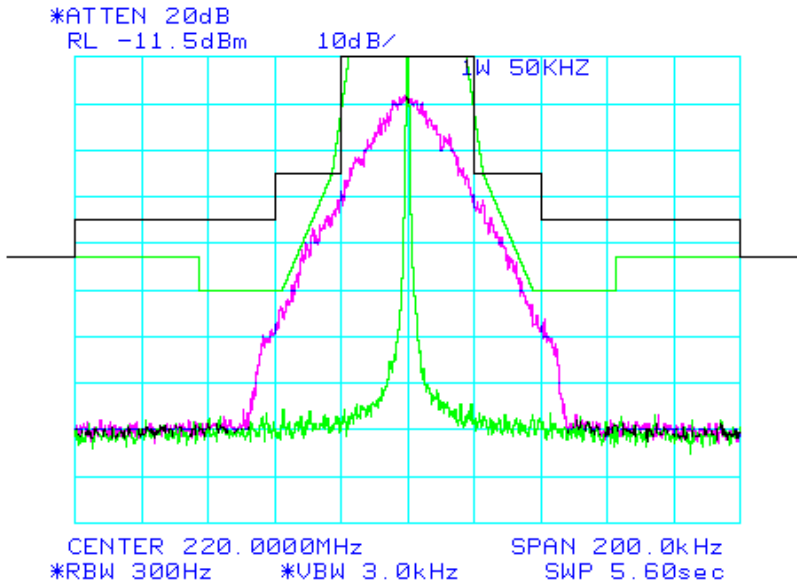

Mask: C 50 kHz Spectrum for Emission: 34K0 F1D
Output Power = 2 Watt Data Rate: 64 kbps Peak Deviation with Data: 14.45 kHz
Applicable to Part 90 (217-220 MHz)

Mask B = Black Line
Mask C 50 kHz = Green Line

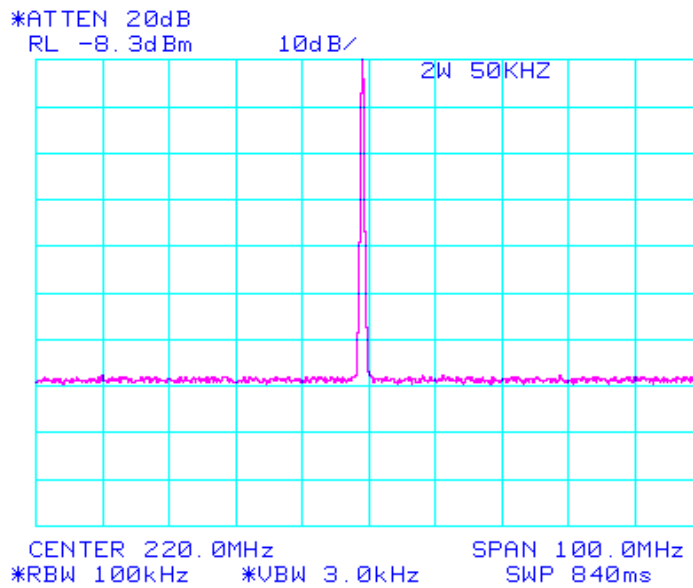
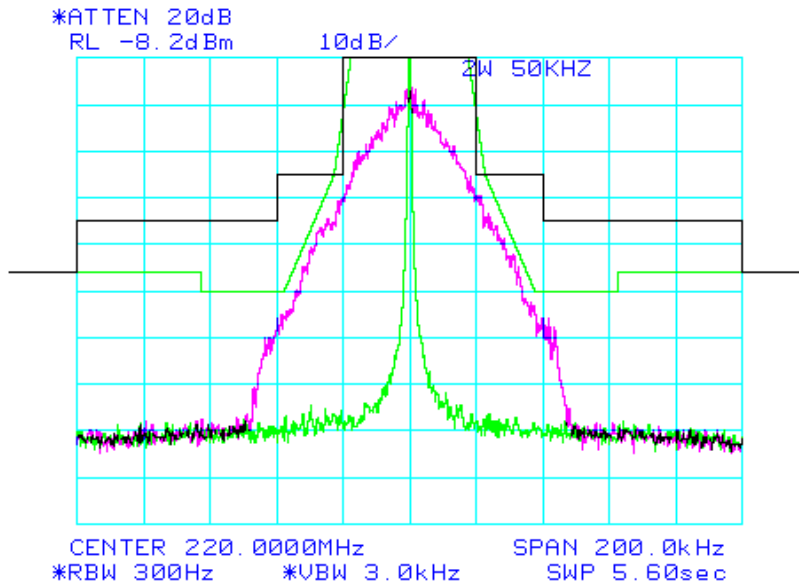

Mask: C 50 kHz Spectrum for Emission: 34K0 F1D
Output Power = 12 Watt Data Rate: 64 kbps Peak Deviation with Data: 14.45 kHz
Applicable to Part 80 (216-220 MHz) only

Mask B = Black Line
Mask C 50 kHz = Green Line

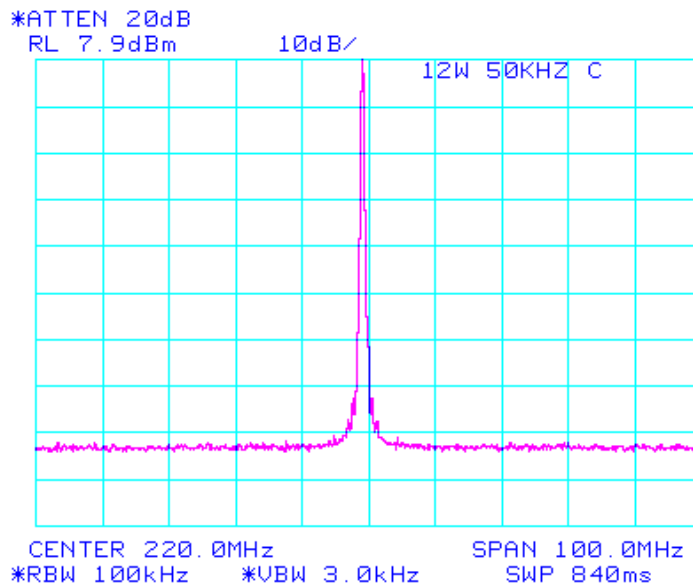
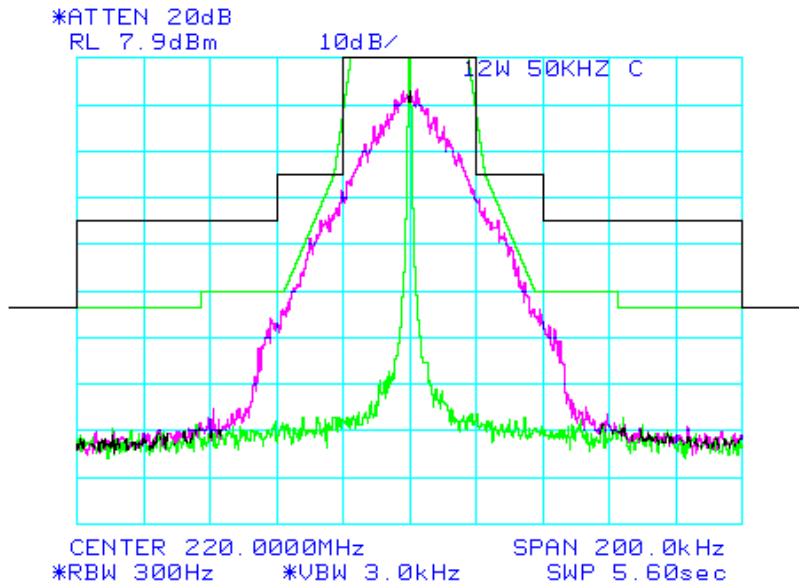

Mask: C 50 kHz
Output Power = 1 Watt

Spectrum for Emission: 36K0 F1D
Data Rate: 96 kbps Peak Deviation with Data: 15.33 kHz

Mask B = Black Line
Mask C 50 kHz = Green Line

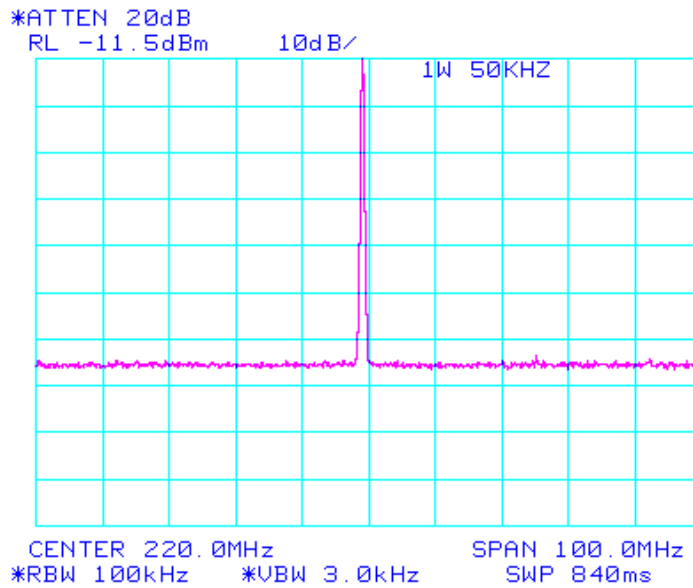
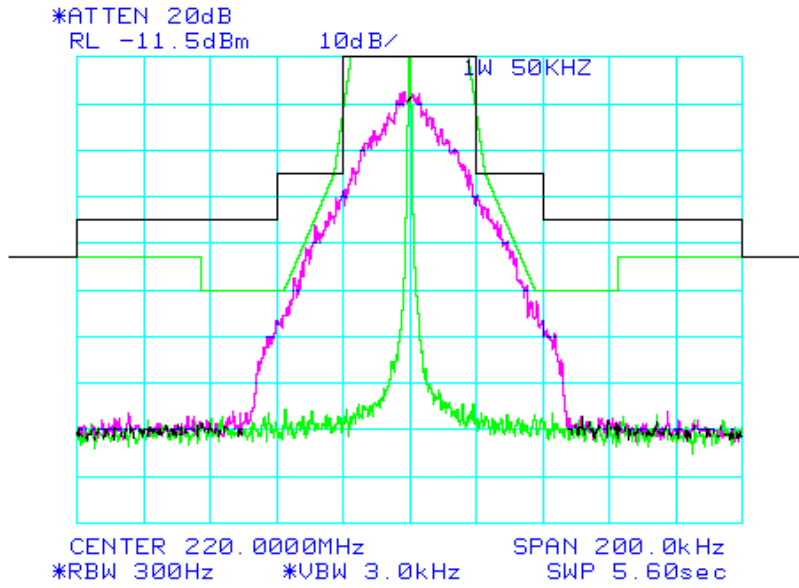

Mask: C 50 kHz Spectrum for Emission: 36K0 F1D
Output Power = 2 Watt Data Rate: 96 kbps Peak Deviation with Data: 15.33 kHz
Applicable to Part 90 (217-220 MHz)

Mask B = Black Line
Mask C 50 kHz = Green Line

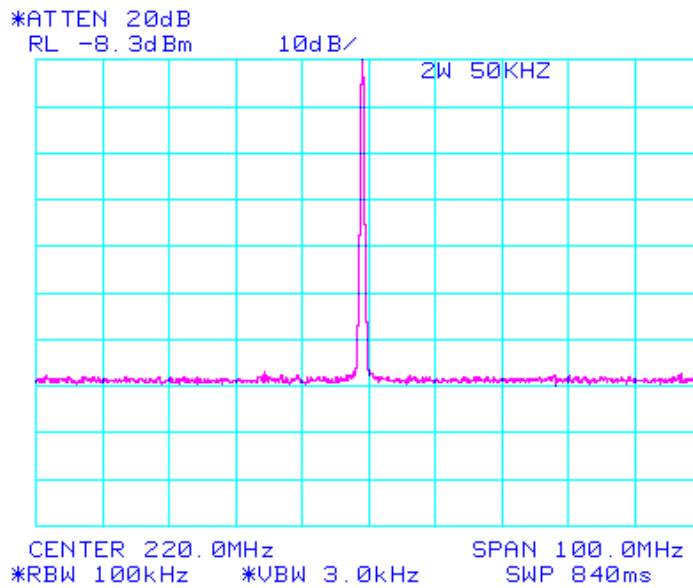
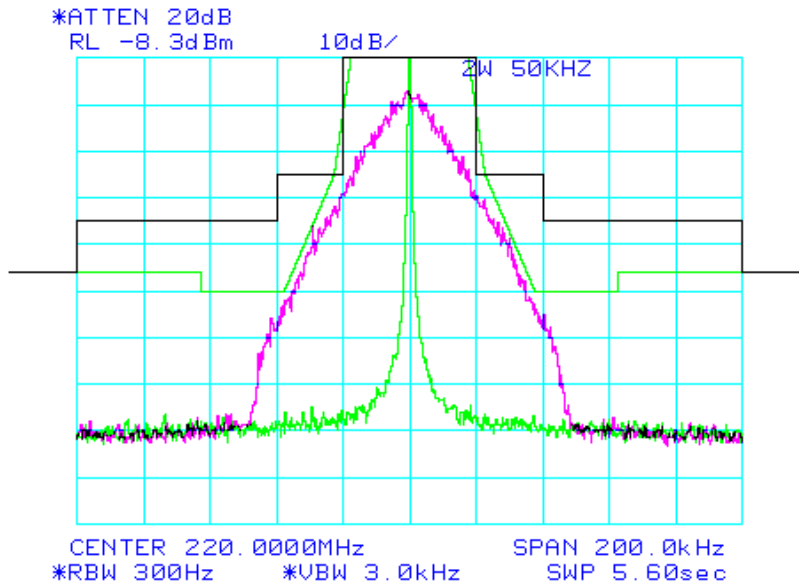

Mask: C 50 kHz Spectrum for Emission: 36K0 F1D
Output Power = 12 Watt Data Rate: 96 kbps Peak Deviation with Data: 15.33 kHz
Applicable to Part 80 (216-220 MHz) only

Mask B = Black Line
Mask C 50 kHz = Green Line

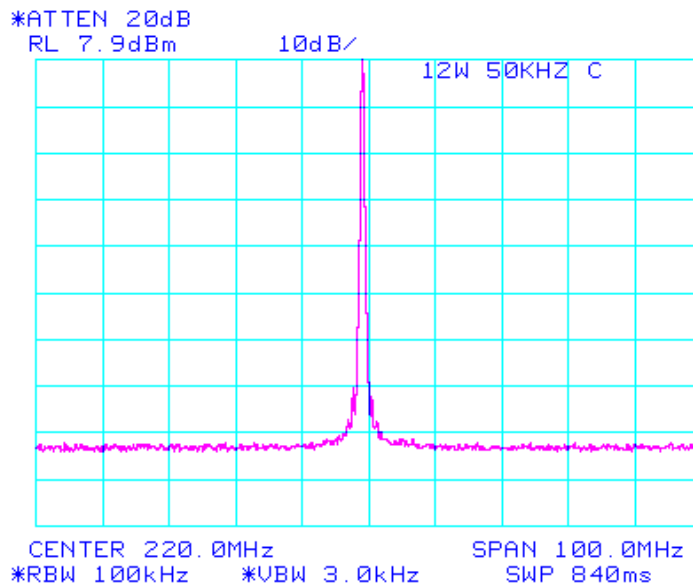
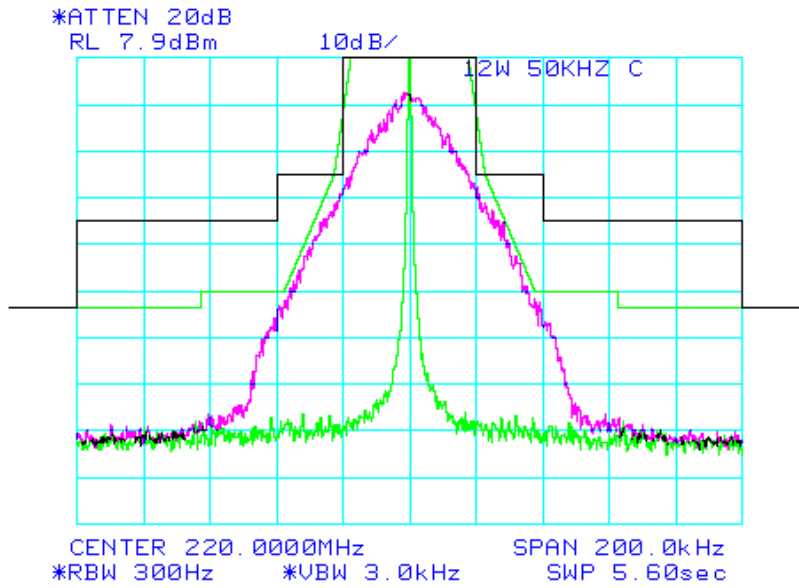

Mask: C 50 kHz
Output Power = 1 Watt

Spectrum for Emission: 33K0 F1D
Data Rate: 128 kbps Peak Deviation with Data: 11.66 kHz

Mask B = Black Line
Mask C 50 kHz = Green Line

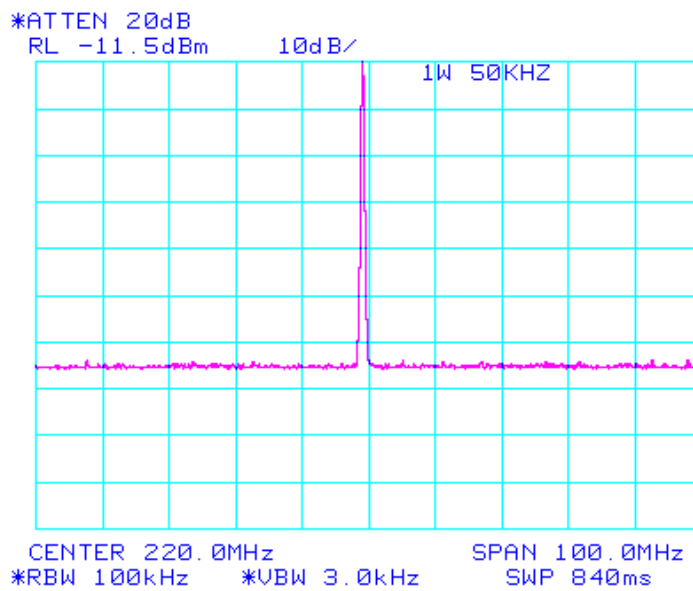
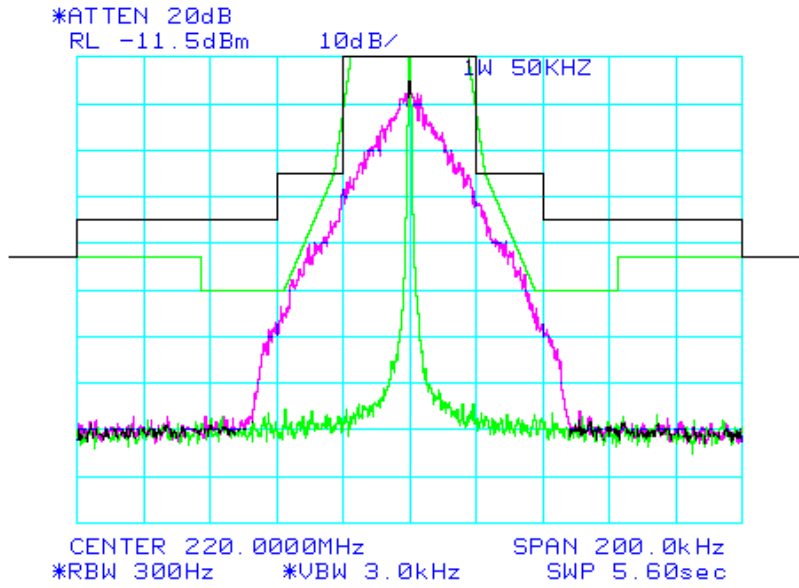

Mask: C 50 kHz Spectrum for Emission: 33K0 F1D
Output Power = 2 Watt Data Rate: 128 kbps Peak Deviation with Data: 11.66 kHz
Applicable to Part 90 (217-220 MHz)

Mask B = Black Line
Mask C 50 kHz = Green Line

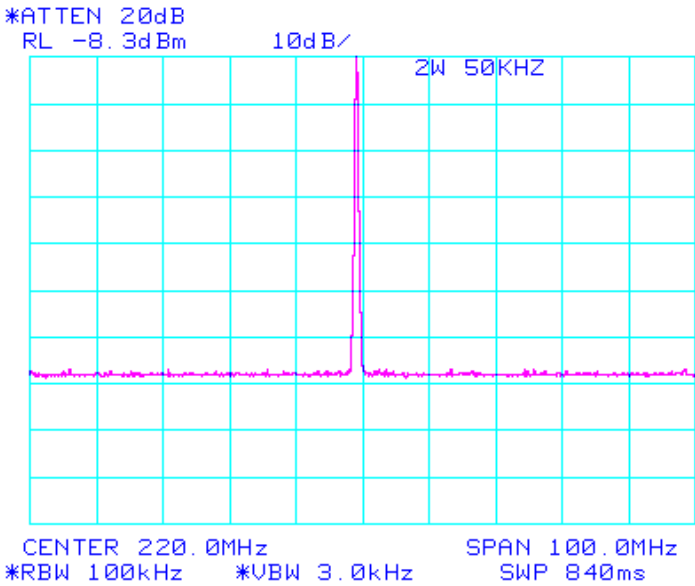
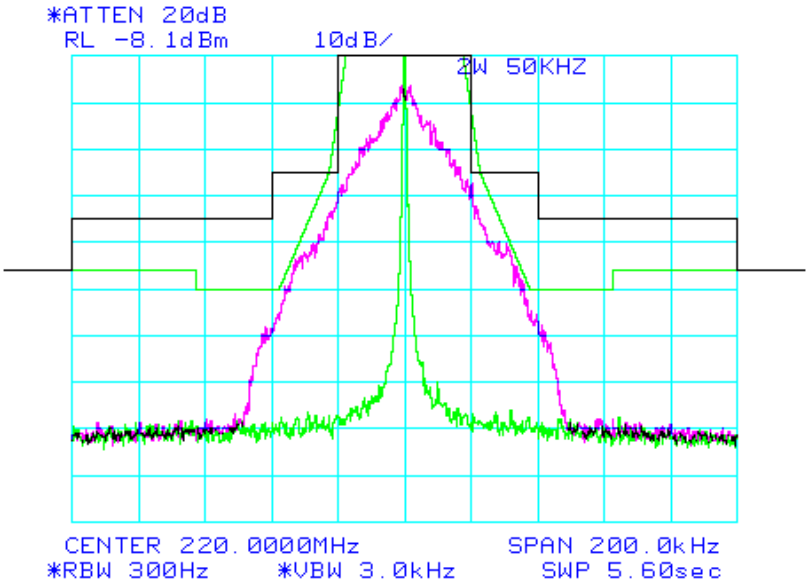

Mask: C 50 kHz Spectrum for Emission: 33K0 F1D
Output Power = 12 Watt Data Rate: 128 kbps Peak Deviation with Data: 11.66 kHz
Applicable to Part 80 (216-220 MHz) only

Mask B = Black Line
Mask C 50 kHz = Green Line

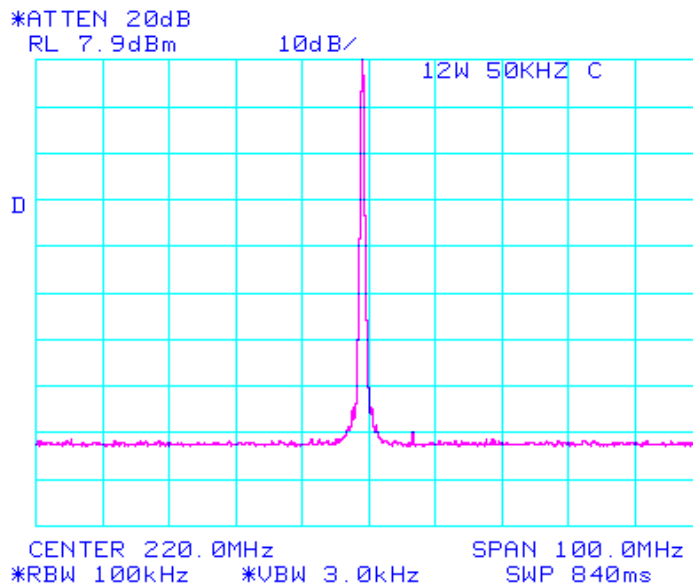
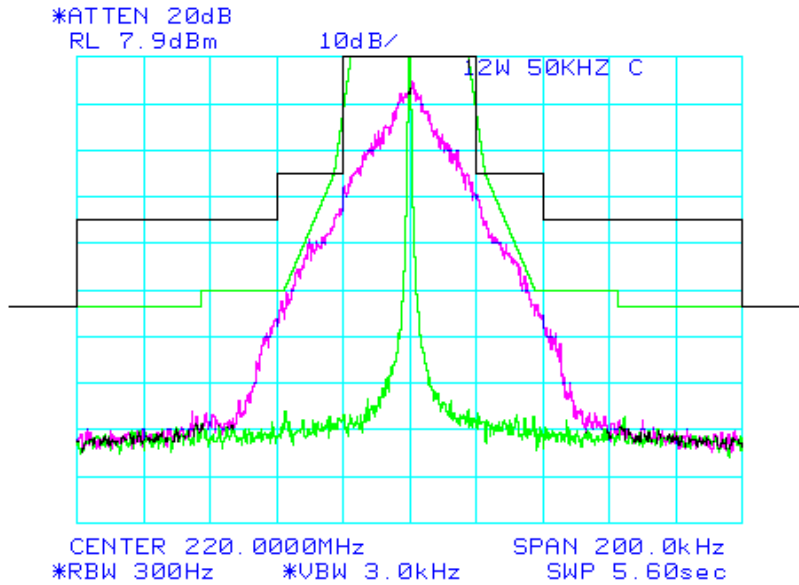

NAME OF TEST: Transmitter Occupied Bandwidth for Emission Designators **3K20F1D, 3K45F1D, 8K50F1D, 8K08F1D, 17K8F1D, 17K0F1D, 33K3F1D, 34K0F1D, 36K0F1D, 33K0F1D,**

RULE PART NUMBER: FCC: 2.202, 90.209 (b)(5), 90.210(f), 2.1049 (c) (1)

MINIMUM STANDARDS: **Mask F**
Sidebands and Spurious [Rule 90.210 (c), P = 12 Watts and P=1 Watt]
Authorized Bandwidth = 5 kHz [Rule 90.209(b) (5)]

From Fo to 2 kHz, down 0 dB.

Greater than 2 kHz to 3.75 kHz, down 30 + 20(fd -2) dB.

On any frequency beyond 3.75 kHz removed from the center of the authorized bandwidth fd: At least 55 + 10 log (P) dB.

The equipment under test will not function inside a single channel in the 220 to 222MHz band. Therefore the EUT was tested using aggregate combinations of channels as follows:

3K20F1D	2 contiguous channels
3K45F1D	2 contiguous channels
8K50F1D	5 contiguous channels
8K08F1D	5 contiguous channels
17K8F1D	10 contiguous channels
17K0F1D	10 contiguous channels
33K3F1D	19 contiguous channels
34K0F1D	19 contiguous channels
36K0F1D	19 contiguous channels
33K0F1D	19 contiguous channels

For emission designators 3K20F1D, 3K45F1D

Attenuation = 0 dB at Fo to 4.5 kHz

Attenuation = 30 dB at 4.5 kHz

Attenuation = 55 dB at 5.25 kHz @ 1W

Attenuation = 65 dB at 5.75 kHz @ 12W

For emission designators 8K50F1D,8K08F1D

Attenuation = 0 dB at Fo to 12 kHz

Attenuation = 30 dB at 12 kHz

Attenuation = 55 dB at 13.25 kHz @ 1W

Attenuation = 65 dB at 13.75 kHz @ 12W

For emission designators 17K8F1D, 17K0F1D

Attenuation = 0 dB at Fo to 24.5 kHz

Attenuation = 30 dB at 24.5 kHz

Attenuation = 55 dB at 25.75 kHz @ 1W

Attenuation = 65 dB at 26.25 kHz @ 12W

For emission designators 33K3F1D, 34K0F1D, 36K0F1D, 33K0F1D

Attenuation = 0 dB at Fo to 47 kHz

Attenuation = 30 dB at 47 kHz

Attenuation = 55 dB at 48.25 kHz @ 1W

Attenuation = 65 dB at 48.75 kHz @ 12W

TEST RESULTS: Meets minimum standards (see data on following page)

TEST CONDITIONS: Standard Test Conditions, 25 C
RF Power Level = 1 Watt and 12 Watts
Voltage = 20VDC

TEST PROCEDURE: TIA/EIA – 603-C, 2.2.13, 3.2.11.2

TEST EQUIPMENT: 50-Ohm Attenuator, Bird Electronics Model 50-A-FFN-20 (20dB, 50W)
50-Ohm Attenuator, Bird Electronics Model 10-A-MFN-10 (10dB, 10W)
50-Ohm Attenuator, Pasternack Model PE7002-10 (10dB)
DC Power Supply, Hewlett Packard Model 6653A
Spectrum Analyzer, Hewlett Packard Model HP8563E
Modulation Analyzer, Hewlett Packard Model HP8901B

TEST SET-UP:

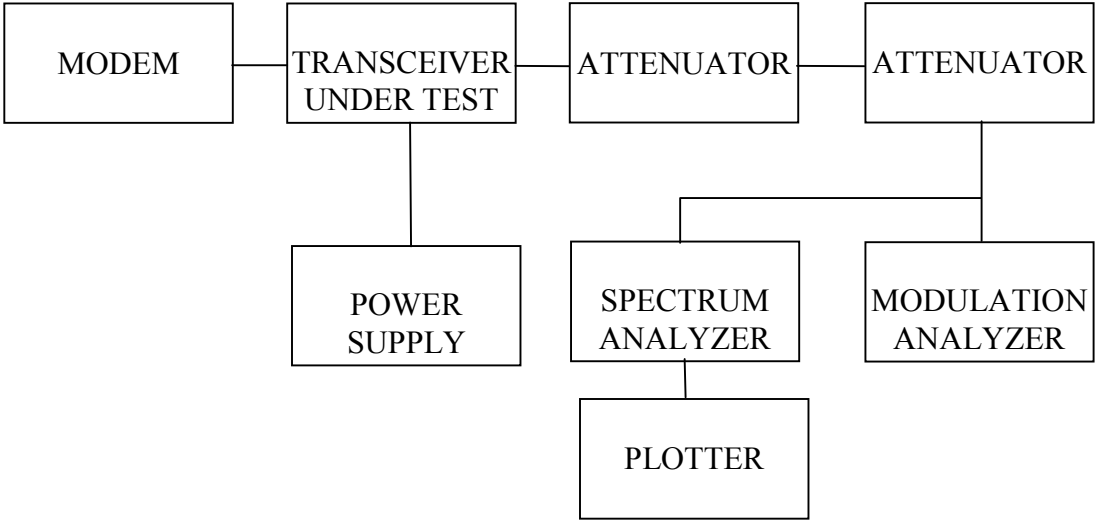

Mask: F (2 aggregate masks)
Output Power = 1 Watt

Spectrum for Emission: 3K20 F1D
Data Rate: 12 kbps Peak Deviation with Data: 1.15 kHz

Mask F = Black Line

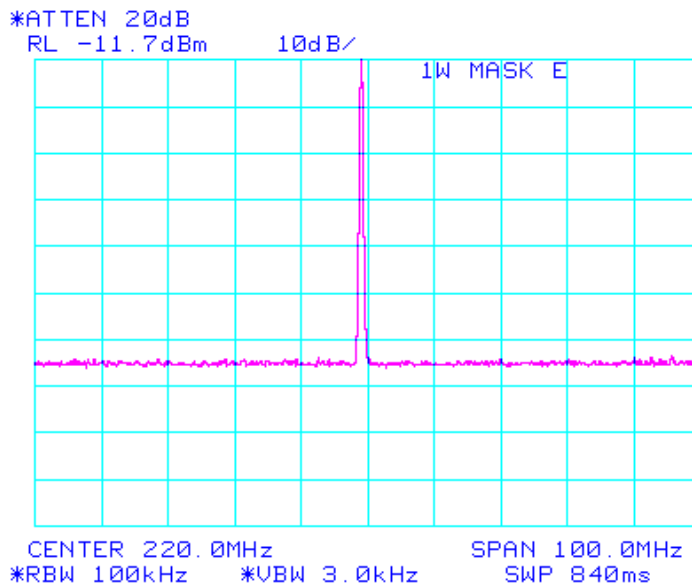
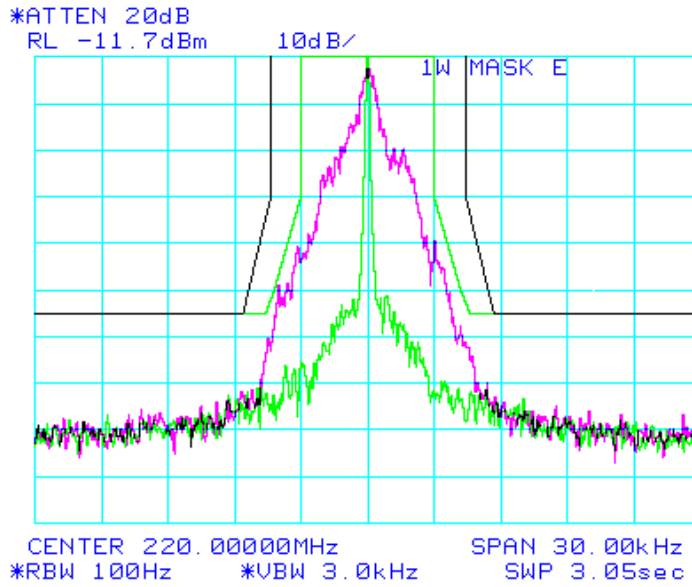

Mask: F (2 aggregate masks)
Output Power = 12 Watt

Spectrum for Emission: 3K20 F1D
Data Rate: 12 kbps Peak Deviation with Data: 1.15 kHz

Mask F = Black Line

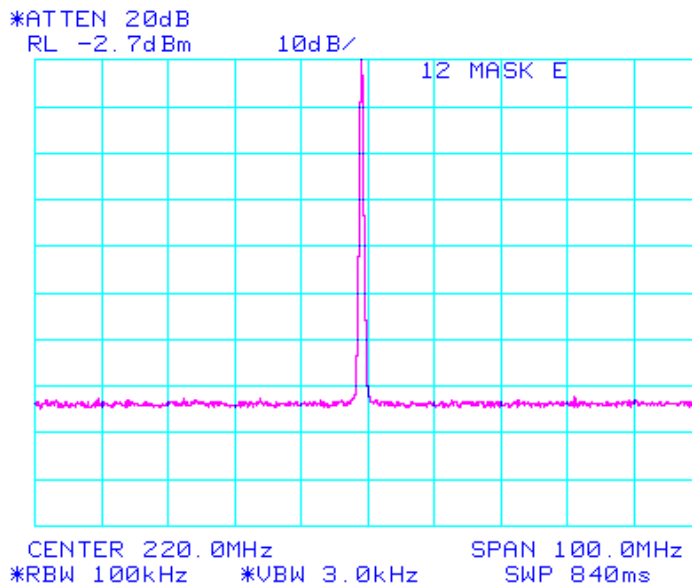
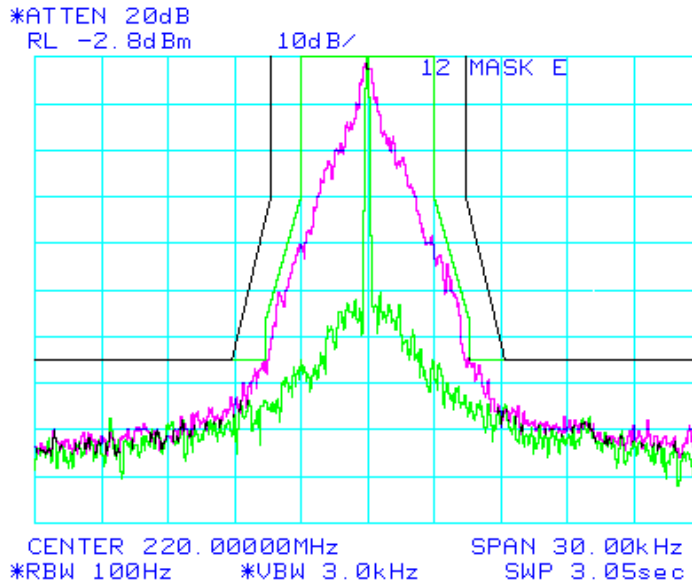

Mask: F (2 aggregate masks)
Output Power = 1 Watt

Spectrum for Emission: 3K45 F1D
Data Rate: 16 kbps Peak Deviation with Data: 1.056 kHz

Mask F = Black Line

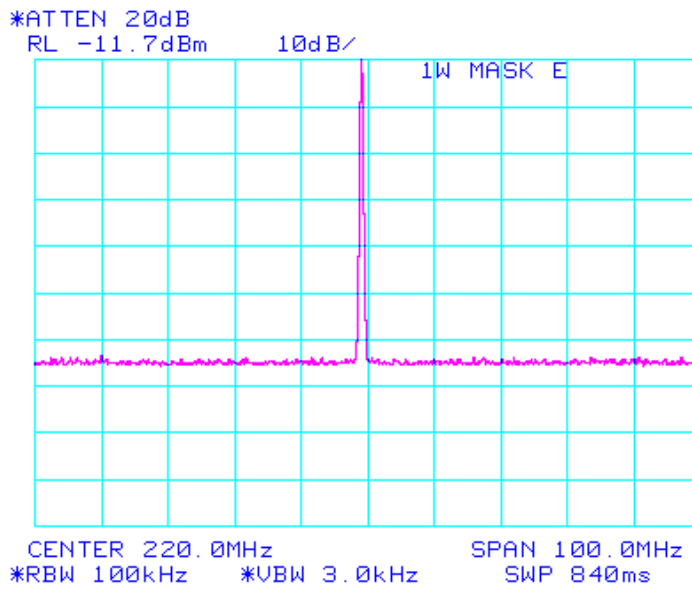
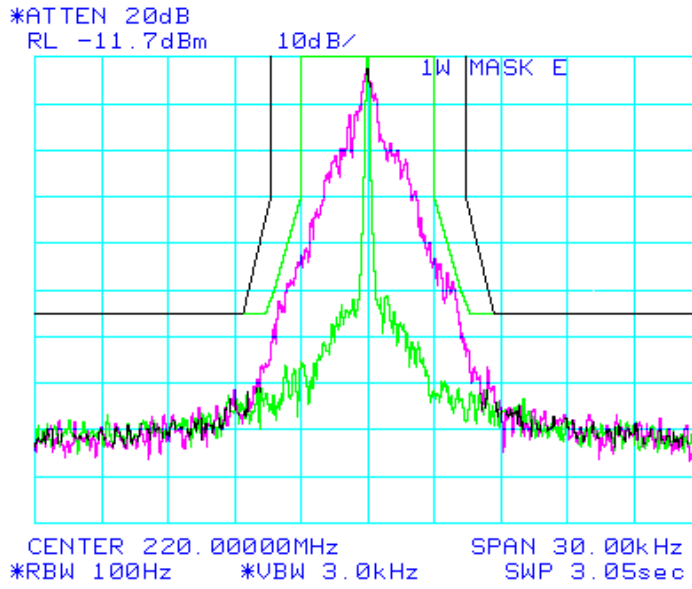

Mask: F (2 aggregate masks)
Output Power = 12 Watt

Spectrum for Emission: 3K45 F1D
Data Rate: 16 kbps Peak Deviation with Data: 1.056 kHz

Mask F = Black Line

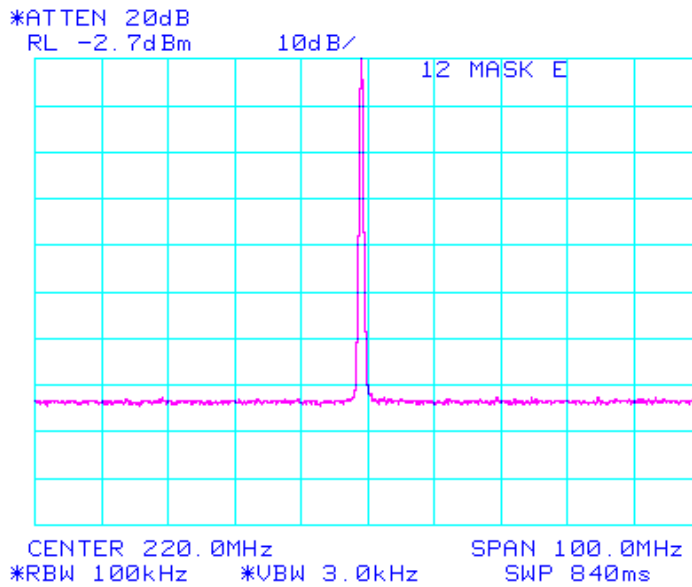
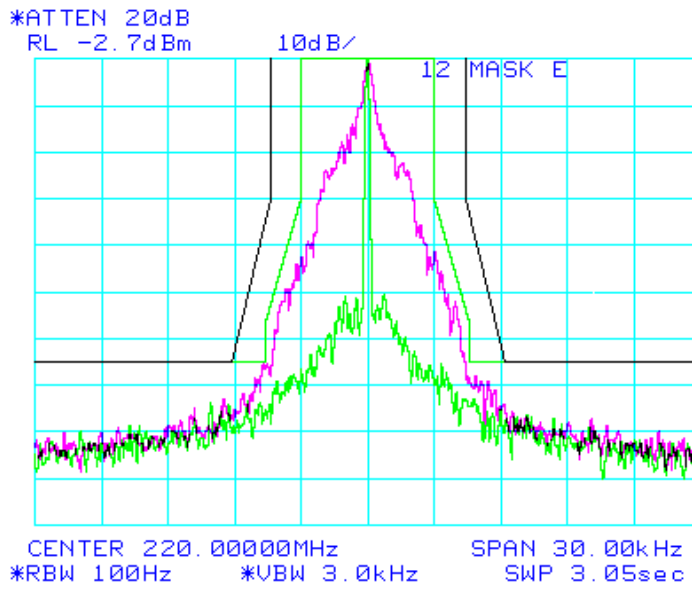

Mask: F (5 aggregate masks)
Output Power = 1 Watt

Spectrum for Emission: 8K50 F1D
Data Rate: 24 kbps Peak Deviation with Data: 3.725 kHz

Mask F = Black Line

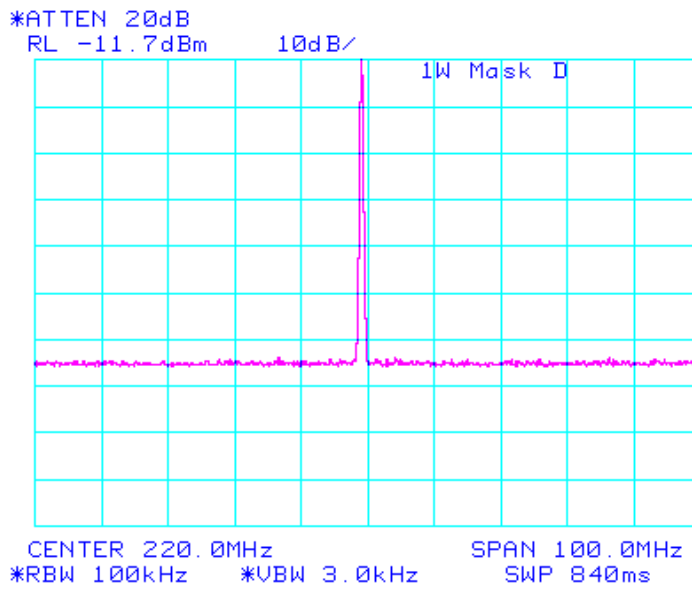
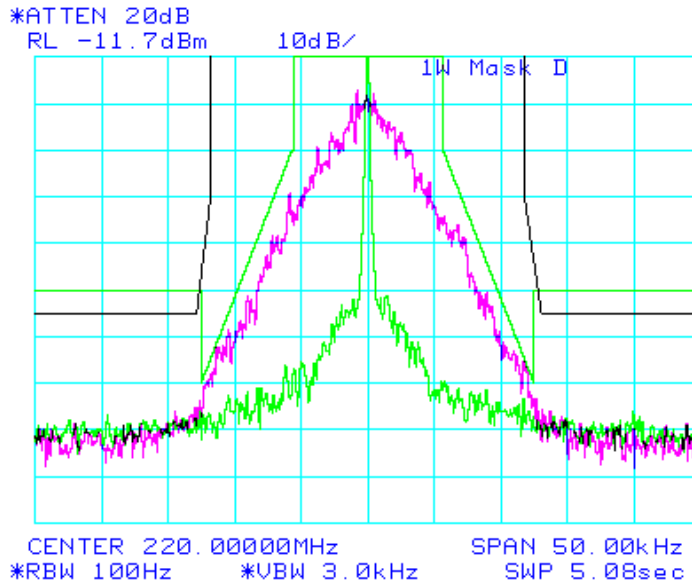

Mask: F (5 aggregate masks)
Output Power = 12 Watt

Spectrum for Emission: 8K50 F1D
Data Rate: 24 kbps Peak Deviation with Data: 3.725 kHz

Mask F = Black Line

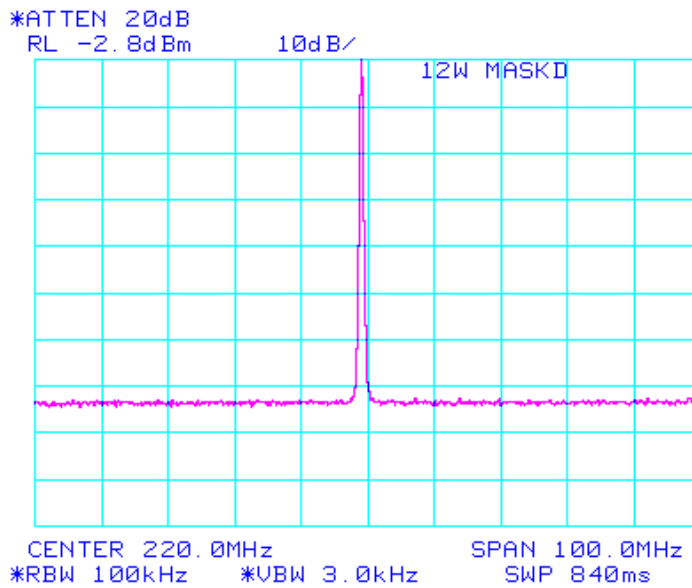
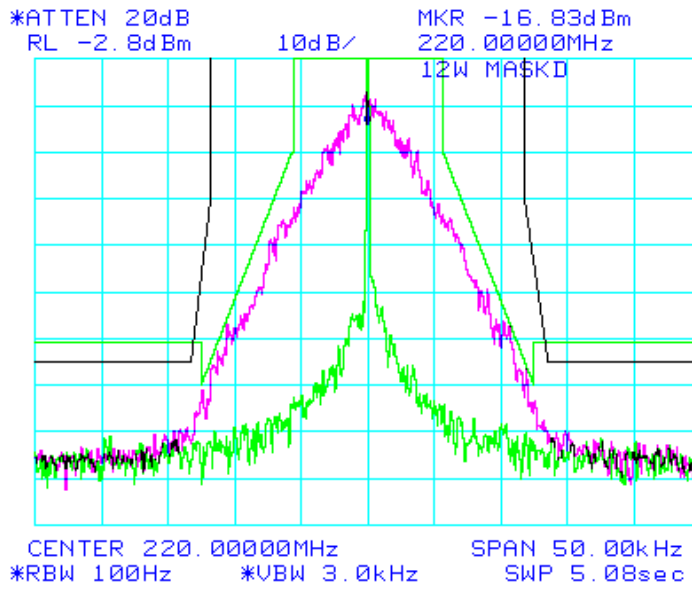

Mask: F (5 aggregate masks)
Output Power = 1 Watt

Spectrum for Emission: 8K08 F1D
Data Rate: 32 kbps Peak Deviation with Data: 3.728 kHz

Mask F = Black Line

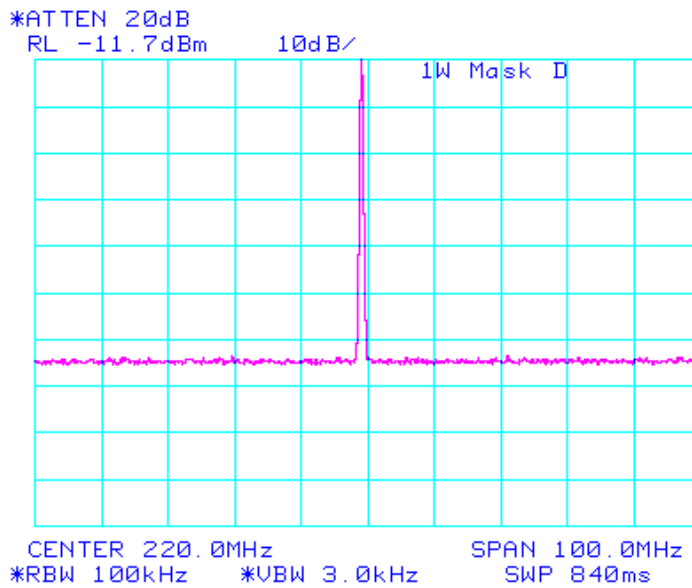
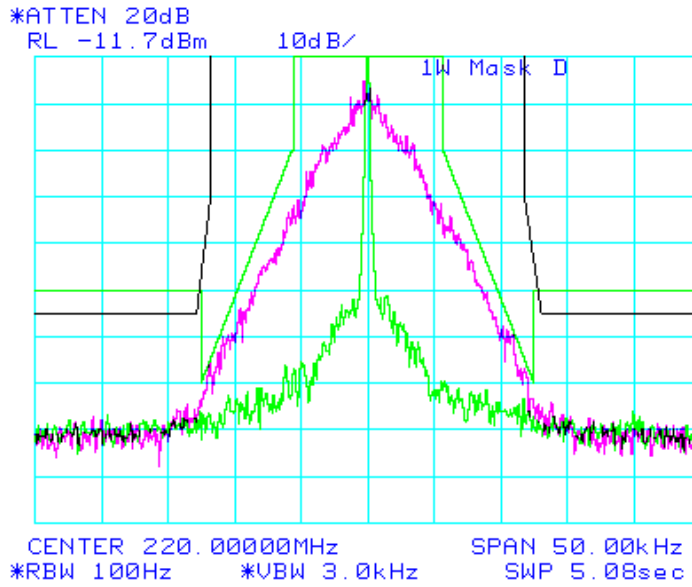

Mask: F (5 aggregate masks)
Output Power = 12 Watt

Spectrum for Emission: 8K08 F1D
Data Rate: 32 kbps Peak Deviation with Data: 3.728 kHz

Mask F = Black Line

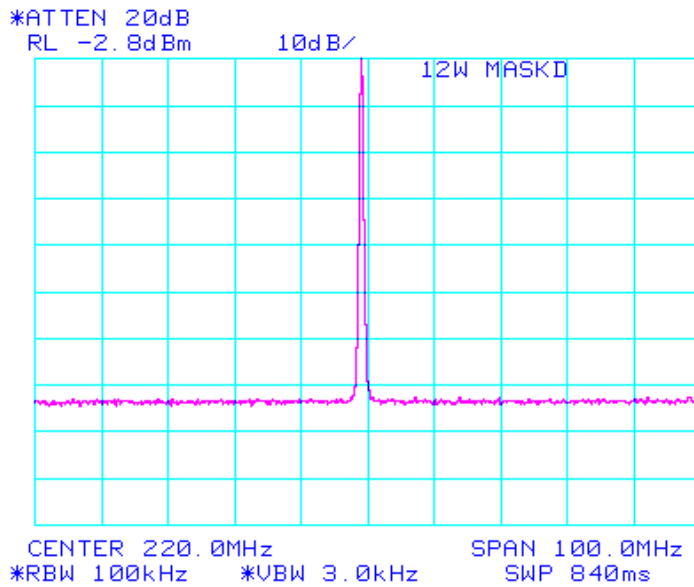
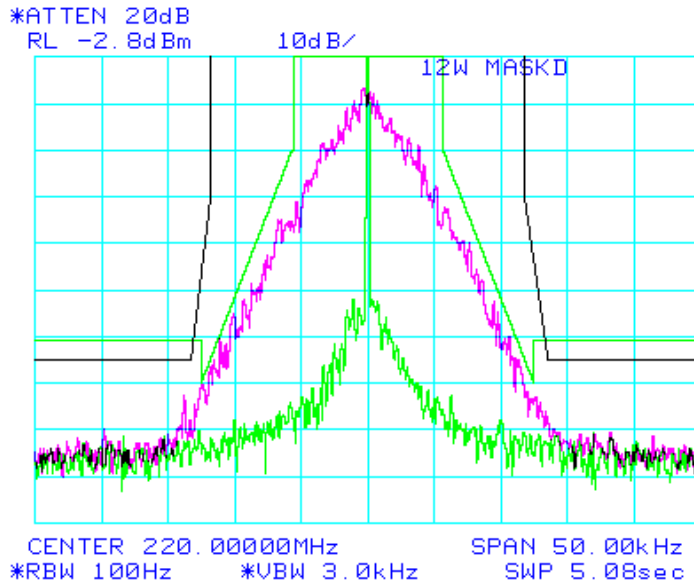

Mask: F (10 aggregate masks)
Output Power = 1 Watt

Spectrum for Emission: 17K8 F1D
Data Rate: 48 kbps Peak Deviation with Data: 7.59 kHz

Mask F = Black Line

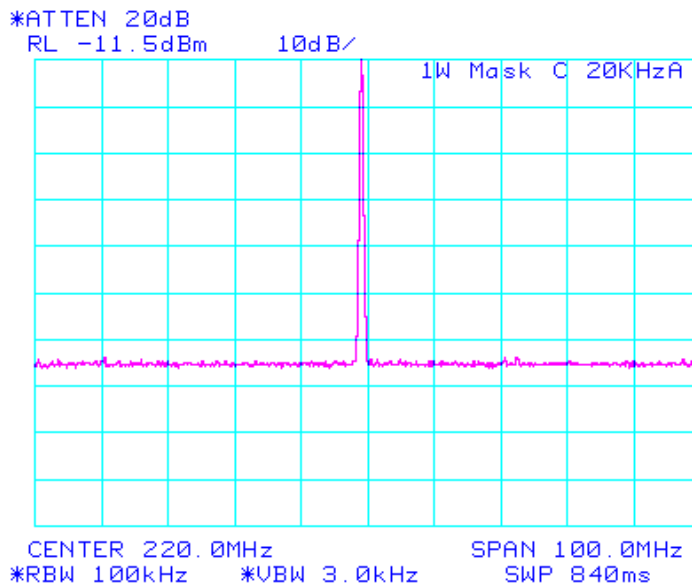
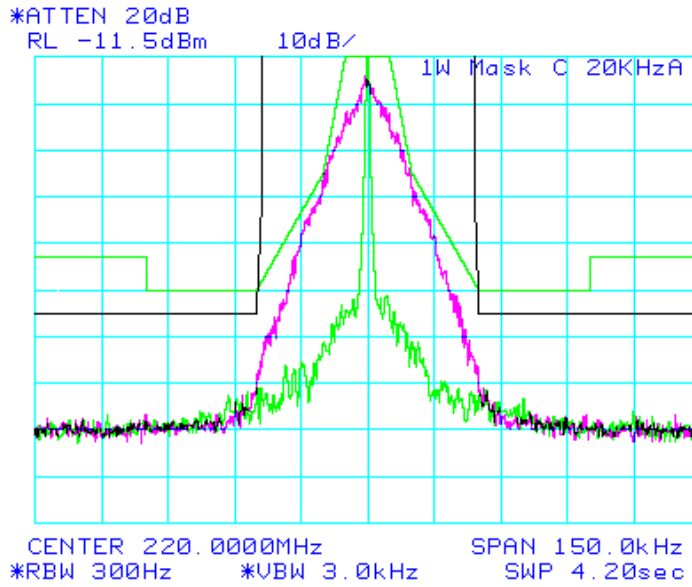

Mask: F (10 aggregate masks)
Output Power = 12 Watt

Spectrum for Emission: 17K8 F1D
Data Rate: 48 kbps Peak Deviation with Data: 7.59 kHz

Mask F = Black Line

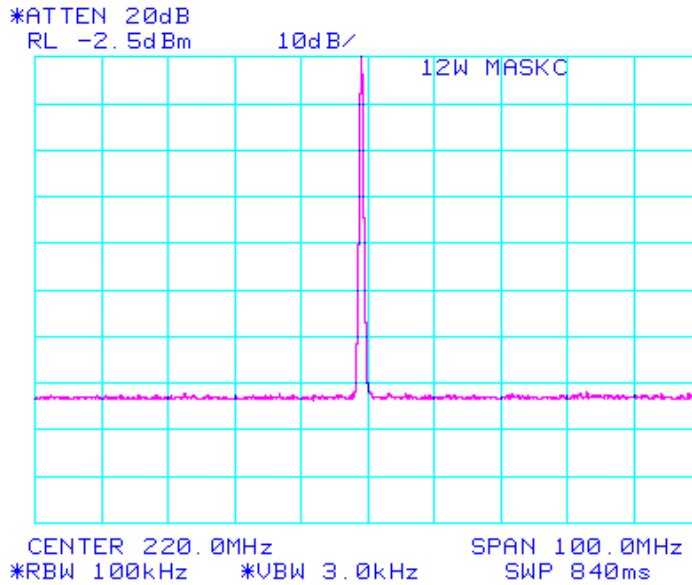
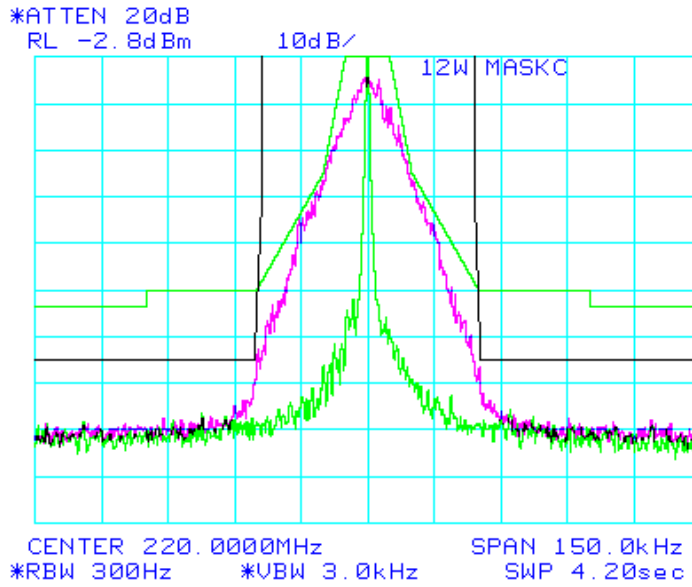

Mask: F (10 aggregate masks)
Output Power = 1 Watt

Spectrum for Emission: 17K0 F1D
Data Rate: 64 kbps Peak Deviation with Data: 7.52 kHz

Mask F = Black Line

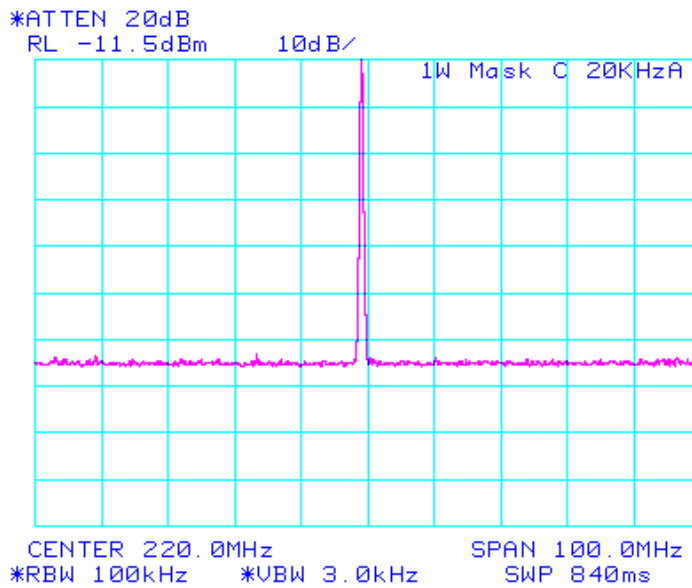
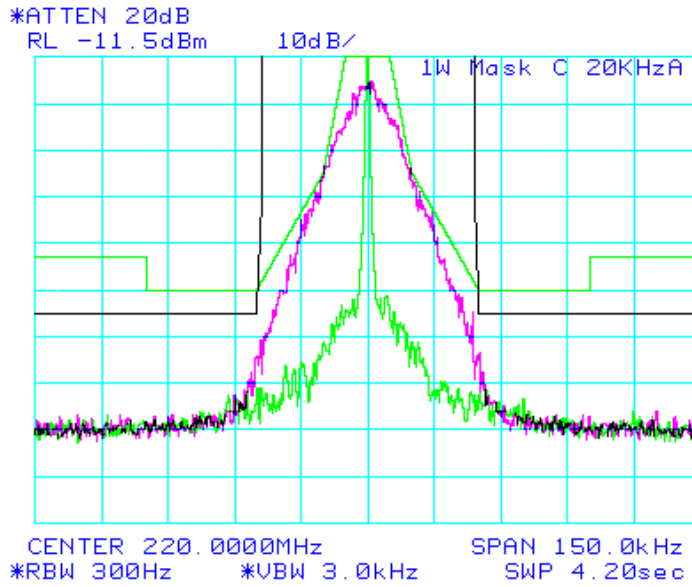

Mask: F (10 aggregate masks)
Output Power = 12 Watt

Spectrum for Emission: 17K0 F1D
Data Rate: 64 kbps Peak Deviation with Data: 7.52 kHz

Mask F = Black Line

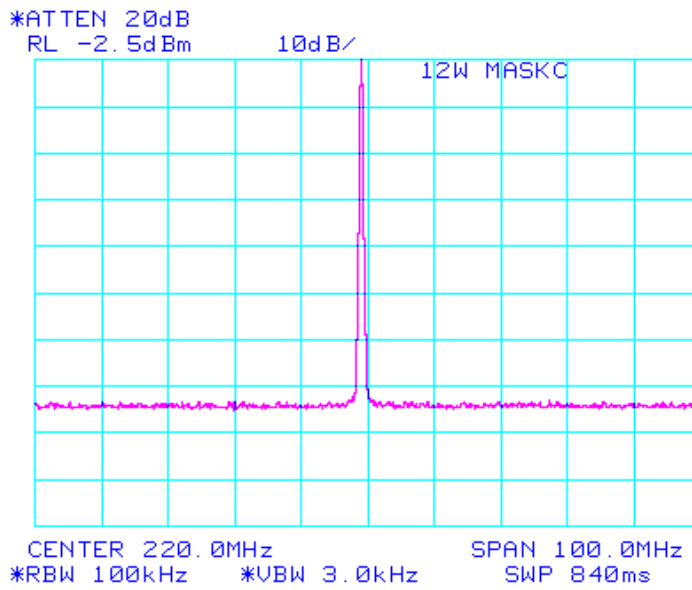
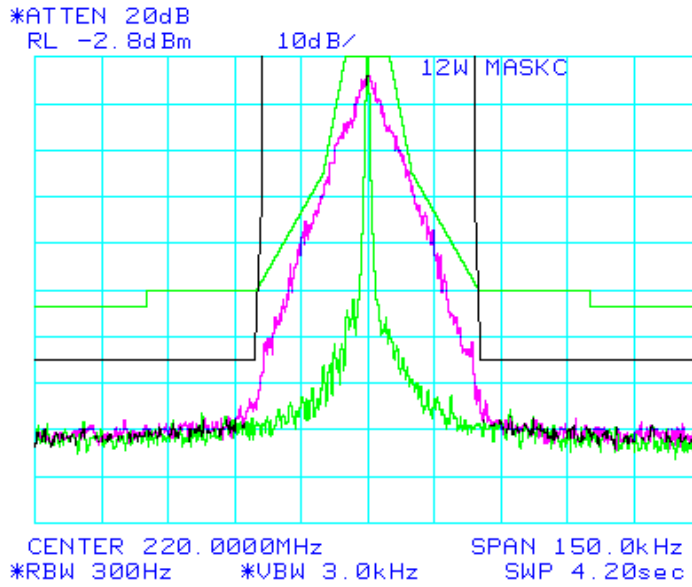

Mask: F (19 aggregate masks)
Output Power = 1 Watt

Spectrum for Emission: 33K3 F1D
Data Rate: 32 kbps Peak Deviation with Data: 12.31 kHz

Mask F = Black Line

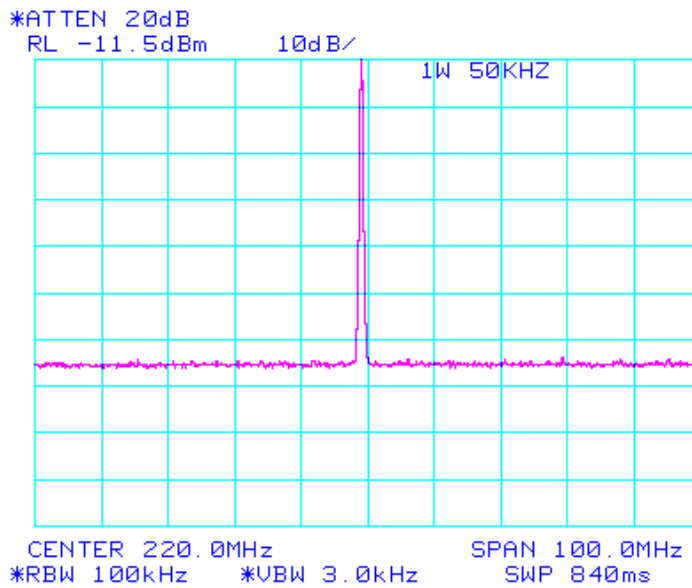
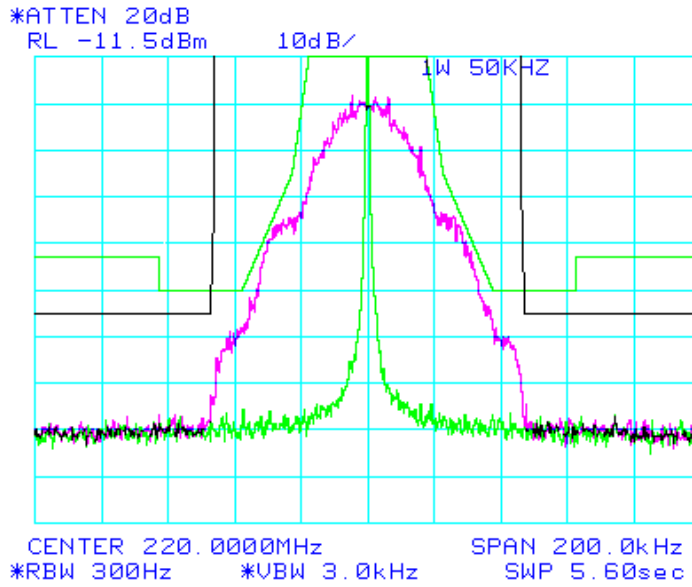

Mask: F (19 aggregate masks)
Output Power = 12 Watt

Spectrum for Emission: 33K3 F1D
Data Rate: 32 kbps Peak Deviation with Data: 12.31 kHz

Mask F = Black Line

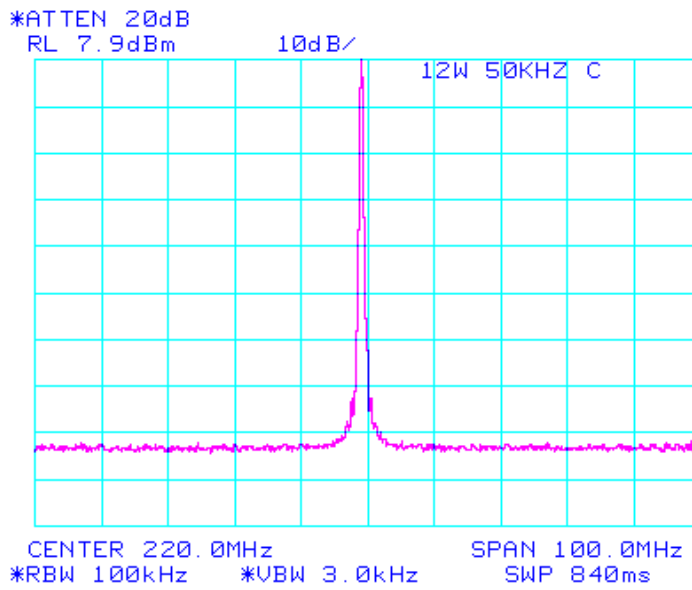
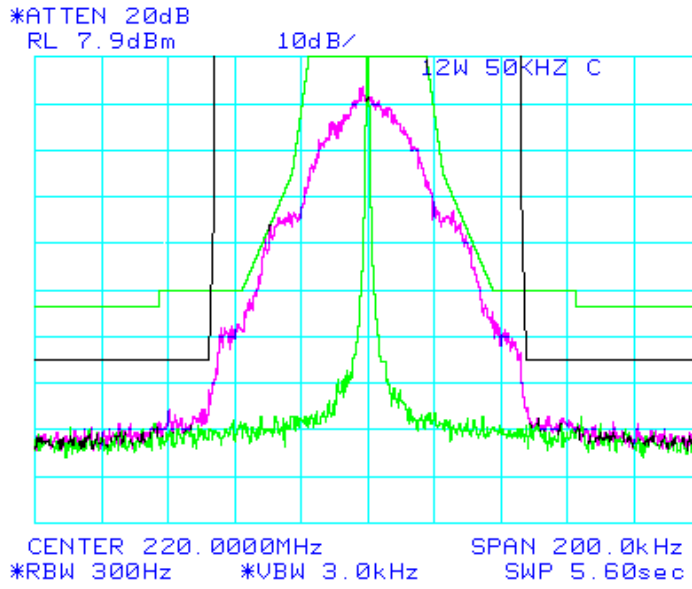

Mask: F (19 aggregate masks)
Output Power = 1 Watt

Spectrum for Emission: 34K0 F1D
Data Rate: 64 kbps Peak Deviation with Data: 14.45 kHz

Mask F = Black Line

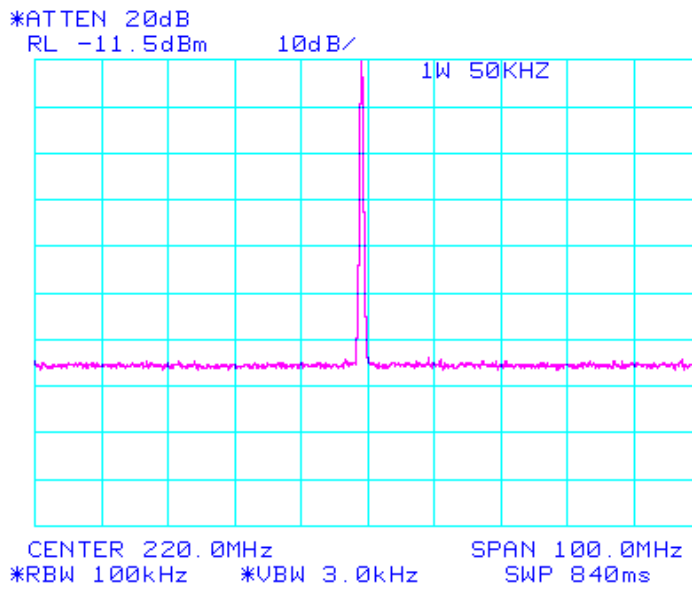
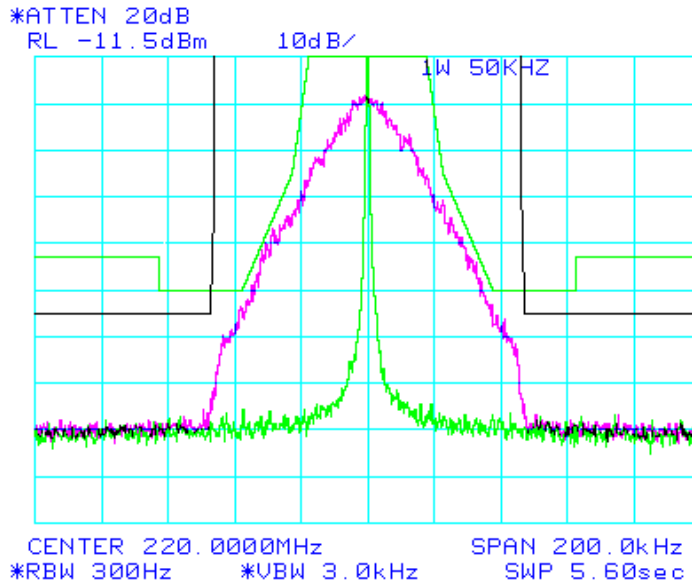

Mask: F (19 aggregate masks)
Output Power = 12 Watt

Spectrum for Emission: 34K0 F1D
Data Rate: 64 kbps Peak Deviation with Data: 14.45 kHz

Mask F = Black Line

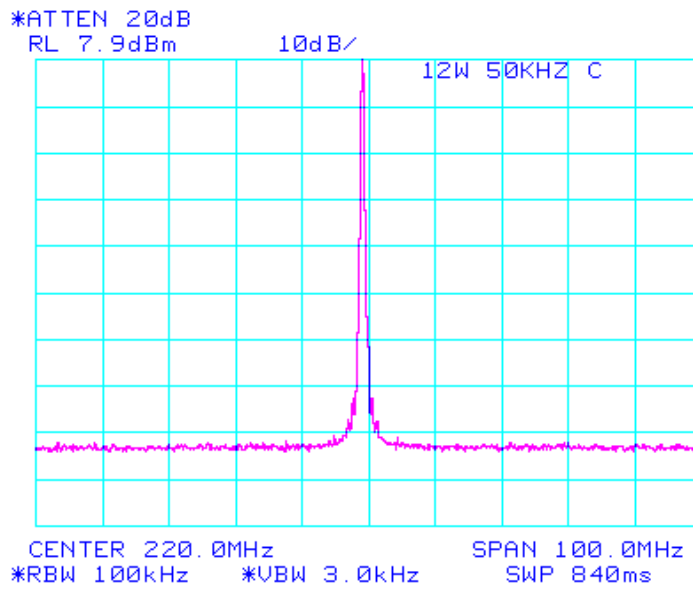
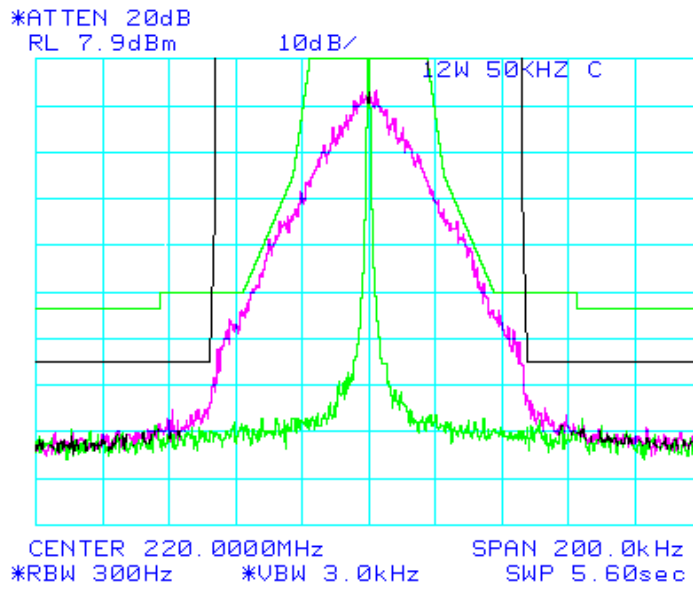

Mask: F (19 aggregate masks)
Output Power = 1 Watt

Spectrum for Emission: 36K0 F1D
Data Rate: 96 kbps Peak Deviation with Data: 15.33 kHz

Mask F = Black Line

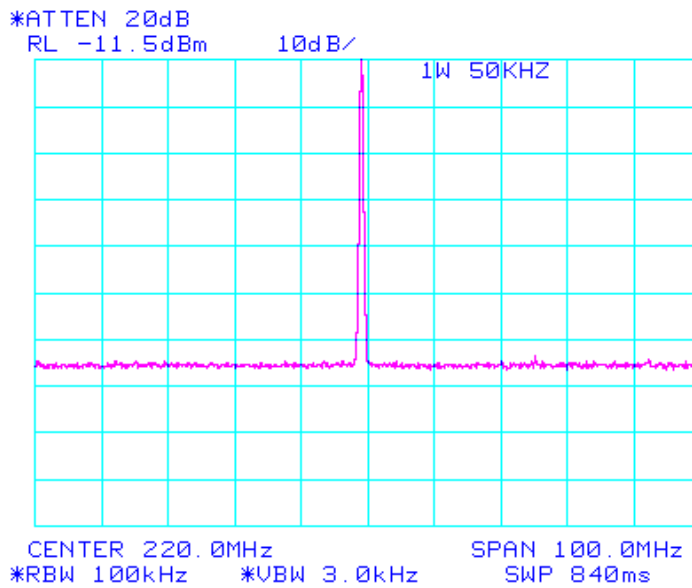
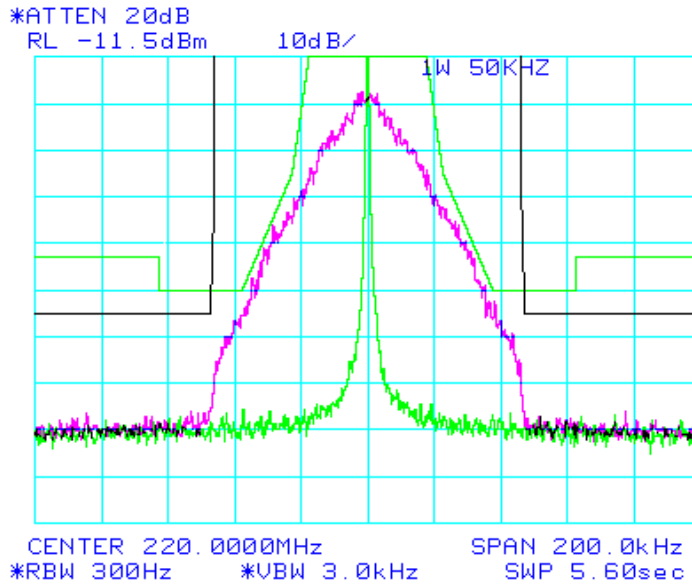

Mask: F (19 aggregate masks)
Output Power = 12 Watt

Spectrum for Emission: 36K0 F1D
Data Rate: 96 kbps Peak Deviation with Data: 15.33 kHz

Mask F = Black Line

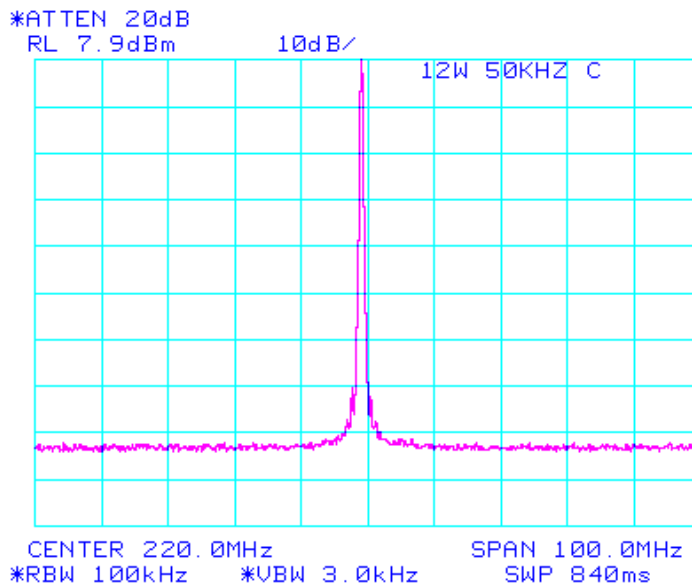
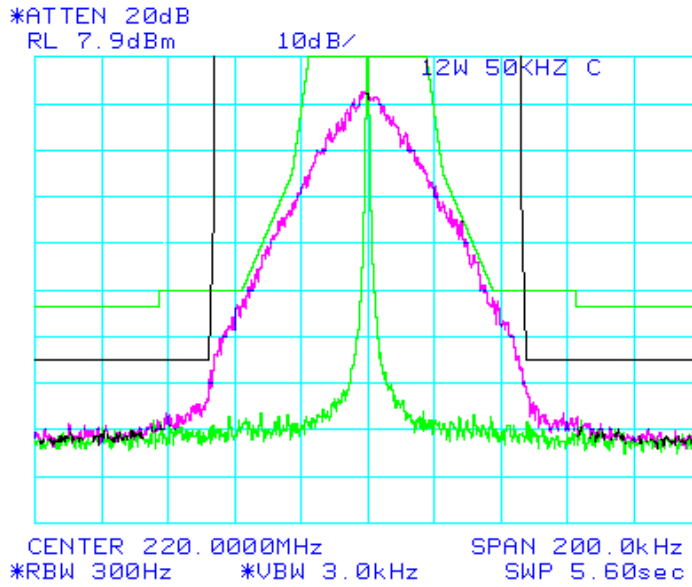

Mask: F (19 aggregate masks)
Output Power = 1 Watt

Spectrum for Emission: 33K0 F1D
Data Rate: 128 kbps Peak Deviation with Data: 11.66 kHz

Mask F = Black Line

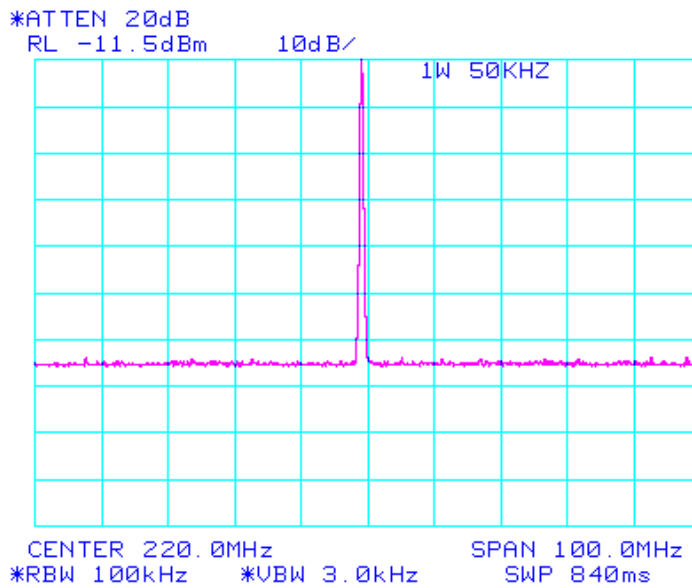
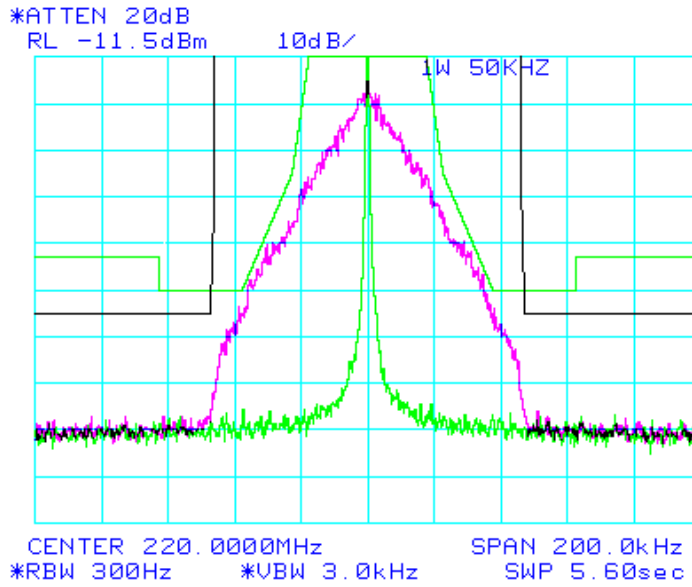

Mask: F (19 aggregate masks)
Output Power = 12 Watt

Spectrum for Emission: 33K0 F1D
Data Rate: 128 kbps Peak Deviation with Data: 11.66 kHz

Mask F = Black Line

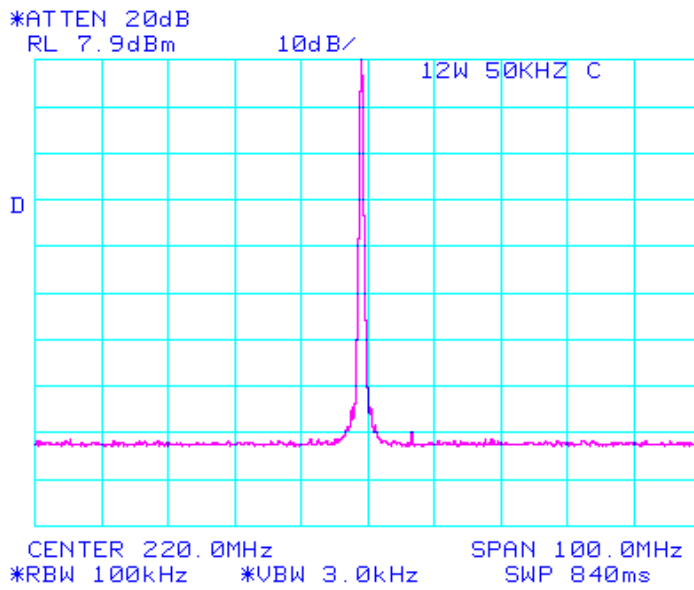
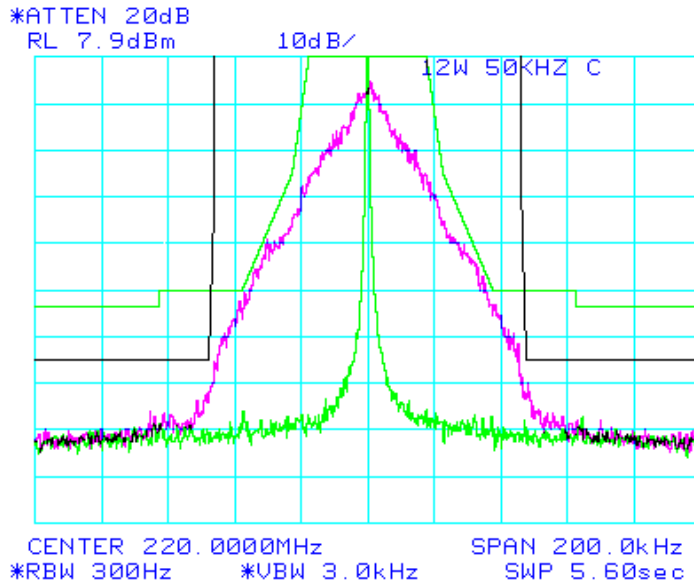

Equipment Calibration Information

Equipment	Serial Number	Cal Date	Cal Due
HP 8563E Spectrum Analyzer	3221A00149	3/23/2008	3/23/2010
Agilent E8257D Signal Generator	MY44320507	3/23/2008	3/23/2010
HP 8901B Modulation Analyzer	3019A02779	3/21/2008	3/21/2010
HP 437B Power Meter	3125U12364	4/19/2008	4/19/2010

Instruments have been calibrated using standards with accuracies traceable to NIST standards.