

CalAmp Wireless Networks Corporation
299 Johnson Avenue, Suite 110
Waseca, MN 56093-0833 USA
Phone: 507-833-8819
Fax: 507-833-6748

FCC Part 90 Certification Application

FCC Form 731

For The

**Viper
VHF RADIO MODEM**

FCC ID: NP4-5018-500

For a Class II Permissive Change

TABLE OF CONTENTS

| | Page # |
|---|--------|
| Test 6: Transmitter Occupied Bandwidth – Mask D | 3 |
| 6.25 kHz Quarter Channel Mask E | 6 |
| 12.5 kHz Half Channel Mask D | 11 |
| 25 kHz Full Channel Mask C | 16 |
| Calibration Information | 21 |

NAME OF TEST: Transmitter Occupied Bandwidth

RULE PART NUMBER: FCC: 2.201, 2.202, 2.1033 (c)(14), 2.1049 (h), 2.1041;90.203(j)(3);
IC: RSS-Gen 4.4.1

Necessary Bandwidth Measurement

This radio modem uses digital modulation signals, passing through a Squared Root Raised Cosine $\alpha=0.2$ or $\alpha=0.5$ DSP implemented low-pass filter to an FM transceiver. The digital modulation is based on SRRC4FSK allows a SRRC2FSK subset to be used for lower bit rate with a better sensitivity reception. The necessary bandwidth calculation for this type of modulation is not covered by paragraphs (1), (2) or (3) from 2.202(c). Therefore, the approach outlined in (2.202(c)(4)) is applicable in this case.

The measurement explanations are provided below.

Necessary Bandwidth Measurement:

| Channel Spacing | Emission Type | Data Rate | Baud Rate | Measured Peak Deviation | Measured 99% Occupied BW |
|-----------------|---------------|-----------|-----------|-------------------------|--------------------------|
| 6.25 kHz | 3K20 F1D | 12 kbps | 4000 | 1.15 kHz | 3.20 kHz |
| 6.25 kHz | 3K45 F1D | 16 kbps | 4000 | 1.056 kHz | 3.45 kHz |
| 12.5 kHz | 8K50 F1D | 24 kbps | 8000 | 3.725 kHz | 8.50 kHz |
| 12.5 kHz | 8K08 F1D | 32 kbps | 8000 | 3.728 kHz | 8.08 kHz |
| 25 kHz | 17K8 F1D | 48 kbps | 16000 | 7.590 kHz | 17.8 kHz |
| 25 kHz | 17K0 F1D | 64 kbps | 16000 | 7.520 kHz | 17.0 kHz |

THEORY OF MEASUREMENT

The way to define the Occupied Bandwidth is “the frequency bandwidth such that, below its lower and above its upper frequency limits, the mean powers radiated are each equal to 0.5 percent of the total mean power radiated by a given emission” (FCC 2.202), the mathematics are as follows:

$$0.005 * TP = P_{(f1)} = \int_0^{f1} PSD_{(f)} df$$

$$0.995 * TP = P_{(f2)} = \int_0^{f2} PSD_{(f)} df$$

$$OBW = f2 - f1$$

where TP (total mean power) is

$$TP = \int_0^{+\infty} PSD_{(f)} df = (1/t) \int_{-\infty}^{+\infty} |z_{(t)}|^2 dt$$

and PSD (power spectral distribution) is

$$PSD_{(f)} = |Z_{(f)}|^2 + |Z_{(-f)}|^2 \quad 0 \leq f < \infty$$

and expresses the positive frequency representation of the transmitter output power for z(t) signal.

By applying these mathematics to the measurements, it is possible to measure the Occupied Bandwidth using a digital spectrum analyzer.

The Occupied Bandwidth measurement is in two parts relatively independent of each other. The first gives the RF spectrum profile, and the second calculates the frequency limits and they result in the Occupied bandwidth. While the first involves RF measurement instrumentation, the second is strictly a computational part related to measured trace.

TEST EQUIPMENT:

- 50-Ohm Attenuator, Bird Electronics Model 50-A-FFN-20 (20dB, 50W)
- 50-Ohm Attenuator, Bird Electronics Model 10-A-MFN-10 (10dB, 10W)
- DC Power Supply, Hewlett Packard Model 6653A
- Spectrum Analyzer, Hewlett Packard Model HP8563E
- Modulation Analyzer, Hewlett Packard Model HP8901A

TEST SET-UP:

For the above requirements, the occupied bandwidth of a transmitter was measured using an HP8563E using the following settings:
 Occupied BW % Power: 99%
 Trace: Max Hold A
 RBW: 100 Hz (6.25 and 12.5 kHz channels)
 RBW: 300 Hz (25 kHz and 50 kHz channels)
 VBW: 3 kHz
 SPAN: 100 kHz (6.25 and 12.5 kHz channels)
 SPAN: 150 kHz (25 kHz channels)
 SPAN: 200 kHz (50 kHz channels)

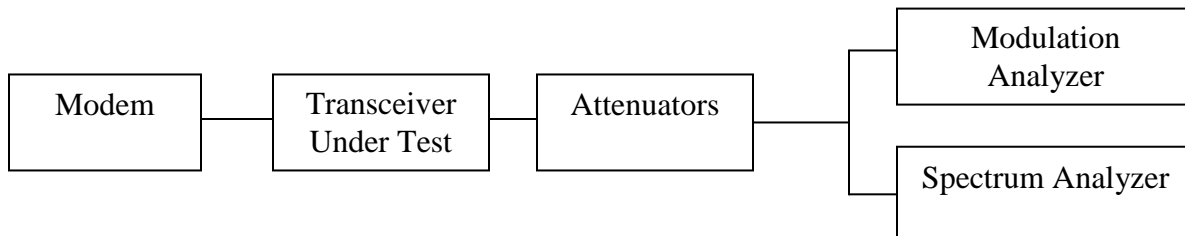

MODULATION SOURCE DESCRIPTION:

The 4-level signaling transmits two information bits per symbol (baud), which yields a bit rate of twice the on-air baud rate. Hence the 64 kbps references in the Installation Guide correspond to a transmitter baud rate of 32000 baud. The 8-level signaling transmits three information bits per symbol (baud), which yields a bit rate of three times the on-air baud rate. Hence the 12, 24, 48, or 96 kbps references in the Installation Guide correspond to a transmitter baud rate of 4000, 8000, 16000 or 32000 baud. The 16-level signaling transmits four information bits per symbol (baud), which yields a bit rate of four times the on-air baud rate. Hence the 16, 32, 64, or 128 kbps references in the Installation Guide correspond to a transmitter baud rate of 4000, 8000, 16000 or 32000baud. That digital signal is digitally filtered (Square Root Raised Cosine pulse shaping with $\alpha=0.2$ or 0.5) by the DSP and converted to I&Q components, then fed to the digital to analog converter. This SRRC4FSK, SRRC8FSK, or SRRC16FSK wave shape applied to the FM modulator will then produce a compact RF spectrum, when using proper frequency deviation, to fit inside the restrictive masks inherent to the intended channel bandwidth.

TX Data Test Pattern:

The transmit “test data” pattern command produces a 107,3741,823 bit pseudo- random pattern. This pattern is generated by the DSP. The 107,3741,823 bit sequence is repeated thereafter as long is necessary to complete the test duration, this sequence lasts 67,109 seconds at 16 kbps. Commonly this is longer than the test duration. This pattern is applied to the DSP modulator for mapping to 4-FSK, 8-FSK and 16-FSK and pulse shaping with SRRC $\alpha=0.2$ or $\alpha=0.5$ depending on the channel selection. This data follows same modulation process as described in MODULATION SOURCE DESCRIPTION and the resulting base band signal feeds the modulator's input of the transceiver.

NAME OF TEST: Transmitter Occupied Bandwidth for Emission Designators
3K20F1D and **3K45F1D**

RULE PART NUMBER: FCC: 2.202, 90.209 (b)(5), 90.210(e), 2.1049 (c) (1);
IC: RSS-119 5.8.4

MINIMUM STANDARDS: **Mask E**
Sidebands and Spurious [Rule 90.210 (e), 5.8.4, P = 12 Watts and P=1 Watt]
Authorized Bandwidth = 6 kHz [Rule 90.209(b) (5), 5.8.4]
From Fo to 3 kHz, down 0 dB.
Greater than 3 kHz to 4.6 kHz, down 30 +16.67(fd-3 kHz) dB or 55 +10 log(P) or 65 dB, whichever is the lesser attenuation.
Greater than 4.6 kHz, at least 55+10log₁₀(P) or 65 dB, whichever is the lesser attenuation.

Attenuation = 0 dB at Fo to 3 kHz
Attenuation = 30 dB at 3 kHz and 56.7 dB at 4.6 kHz @ 12 Watts
Attenuation = 65 dB at frequencies greater than 4.6 kHz @ 12 Watts
Attenuation = 30 dB at 3 kHz and 50 dB at 4.2 kHz and 55 dB at 4.6 kHz @ 1 Watt
Attenuation = 55 dB at frequencies greater than 4.6 kHz @ 1 Watt

TEST RESULTS: Meets minimum standards (see data on following page)

TEST CONDITIONS: Standard Test Conditions, 25 C
RF Power Level = 1 Watt and 12 Watts
Voltage = 20VDC

TEST PROCEDURE: TIA/EIA – 603-C

TEST EQUIPMENT: 50-Ohm Attenuator, Bird Electronics Model 50-A-FFN-20 (20dB, 50W)
50-Ohm Attenuator, Bird Electronics Model 10-A-MFN-10 (10dB, 10W)
50-Ohm Attenuator, Pasternack Model PE7002-10 (10dB)
DC Power Supply, Hewlett Packard Model 6653A
Spectrum Analyzer, Hewlett Packard Model HP8563E
Modulation Analyzer, Hewlett Packard Model HP8901B

TEST SET-UP:

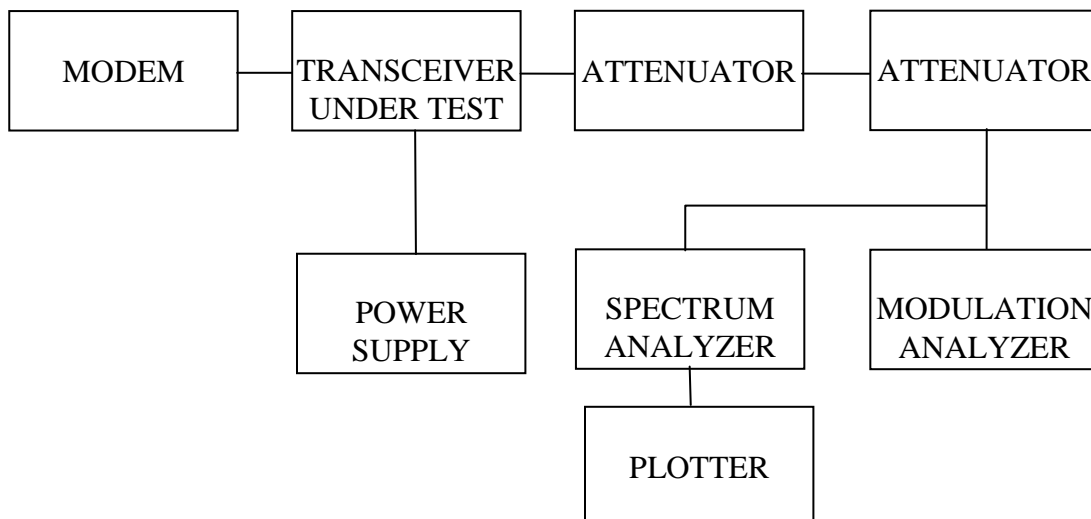

Mask: E, 1W
Output Power = 1 Watt

Spectrum for Emission: 3K20 F1D
Data Rate: 12 kbps Peak Deviation with Data: 1.15kHz

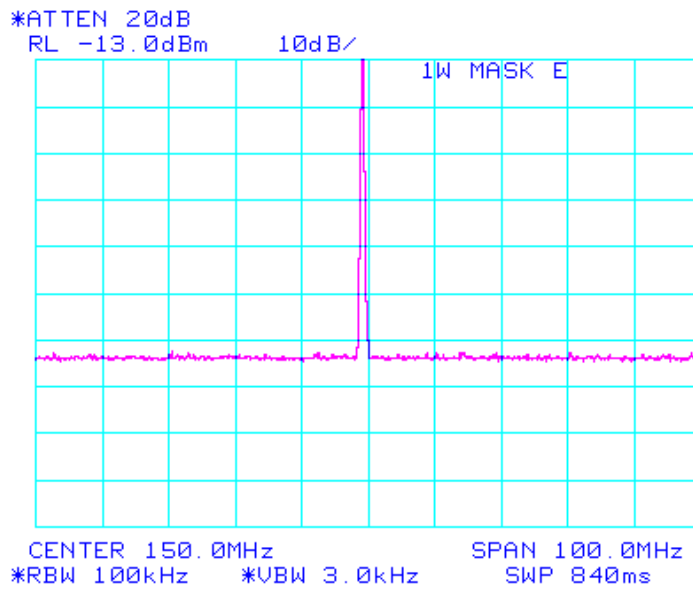
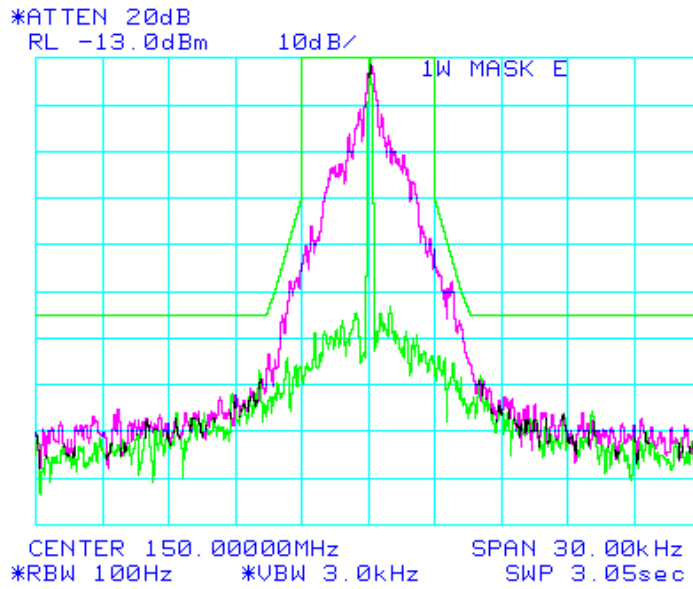

Output Power = 12 Watt

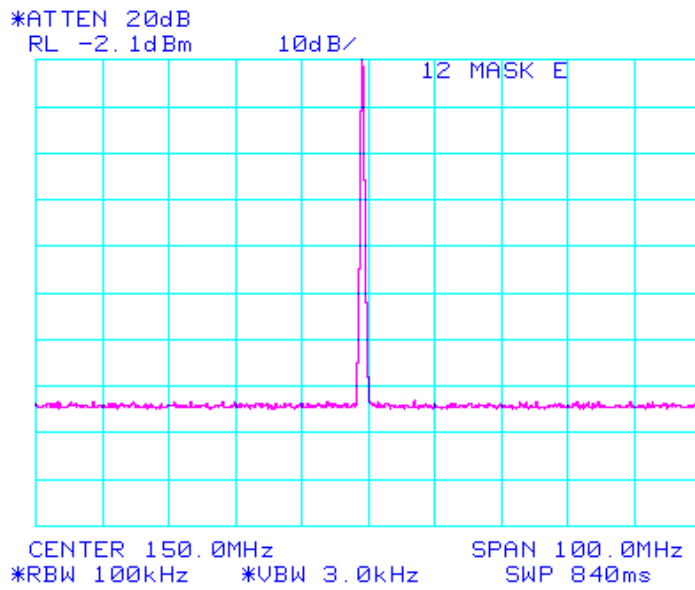
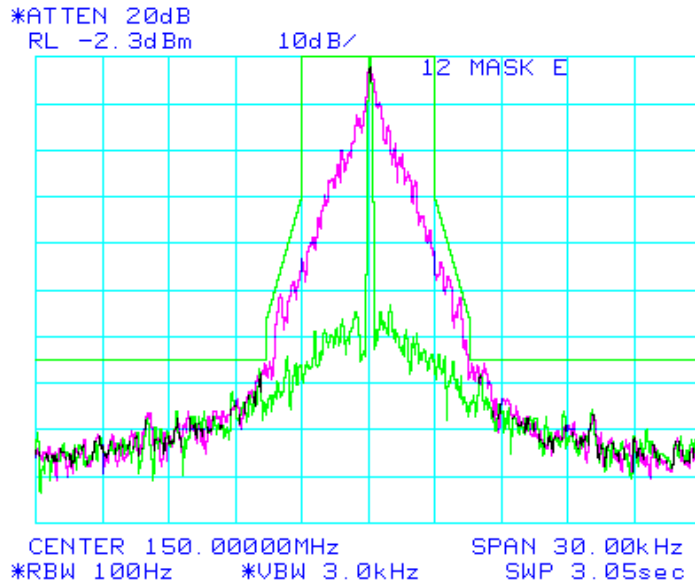

Mask: E, 1W
Output Power = 1 Watt

Spectrum for Emission: 3K45 F1D
Data Rate: 16 kbps Peak Deviation with Data: 1.056 kHz

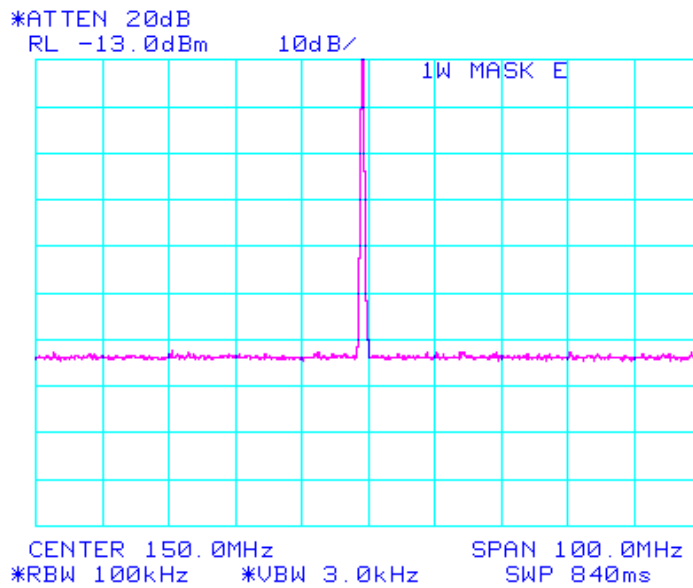
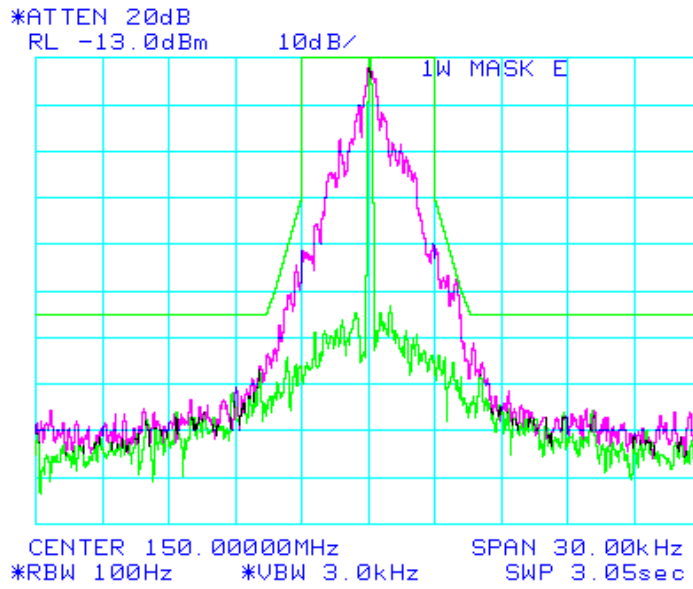

Output Power = 12 Watt

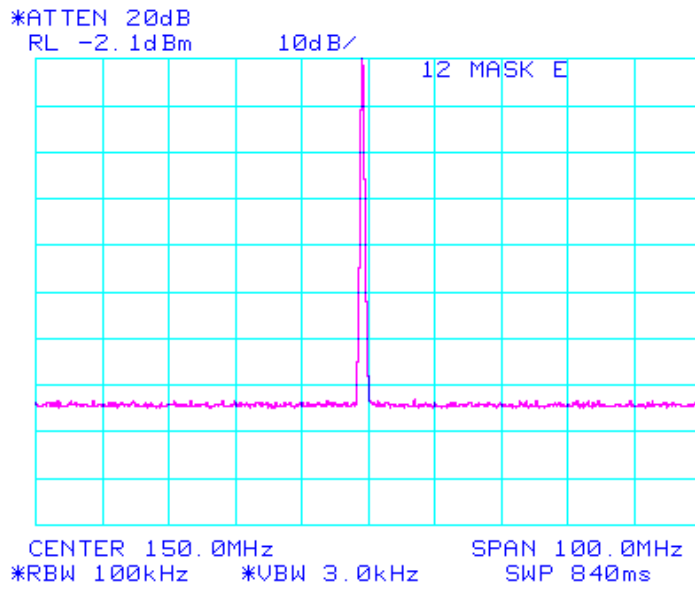
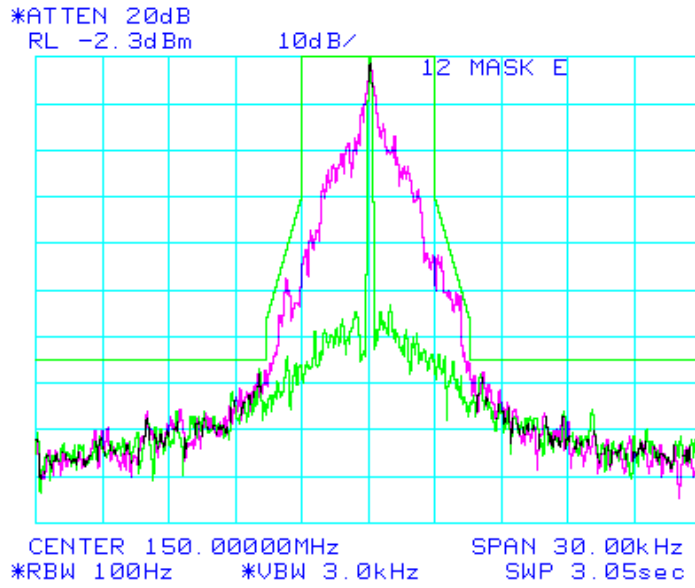

NAME OF TEST: Transmitter Occupied Bandwidth for Emission Designators
8K50F1D and **8K08F1D**

RULE PART NUMBER: FCC: 2.202, 90.209 (b)(5), 90.210(d), 2.1049 (c) (1)
IC: RSS-119 5.8.3

MINIMUM STANDARDS: **Mask D**
Sidebands and Spurious [Rule 90.210 (d), 5.8.3, P = 12 Watts and P=1 Watt]
Authorized Bandwidth = 11.25 kHz [Rule 90.209(b) (5), 5.8.3]
From Fo to 5.625 kHz, down 0 dB.
Greater than 5.625 kHz to 12.5 kHz, down 7.27($f_d - 2.88\text{kHz}$) dB.
Greater than 12.5 kHz, at least 50+10log₁₀(P) or 70 dB, whichever is the lesser attenuation.

Attenuation = 0 dB at Fo to 5.625 kHz
Attenuation = 20 dB at 5.625 kHz and 70 dB at 12.5 kHz
Attenuation = 60.8 dB at frequencies greater than 12.5 kHz @ 12 W
Attenuation = 50 dB at frequencies greater than 12.5 kHz @ 1 W

TEST RESULTS: Meets minimum standards (see data on following page)

TEST CONDITIONS: Standard Test Conditions, 25 C
RF Power Level = 1 Watt and 12 Watts
Voltage = 20VDC

TEST PROCEDURE: TIA/EIA – 603-C

TEST EQUIPMENT: 50-Ohm Attenuator, Bird Electronics Model 50-A-FFN-20 (20dB, 50W)
50-Ohm Attenuator, Bird Electronics Model 10-A-MFN-10 (10dB, 10W)
50-Ohm Attenuator, Pasternack Model PE7002-10 (10dB)
DC Power Supply, Hewlett Packard Model 6653A
Spectrum Analyzer, Hewlett Packard Model HP8563E
Modulation Analyzer, Hewlett Packard Model HP8901A

TEST SET-UP:

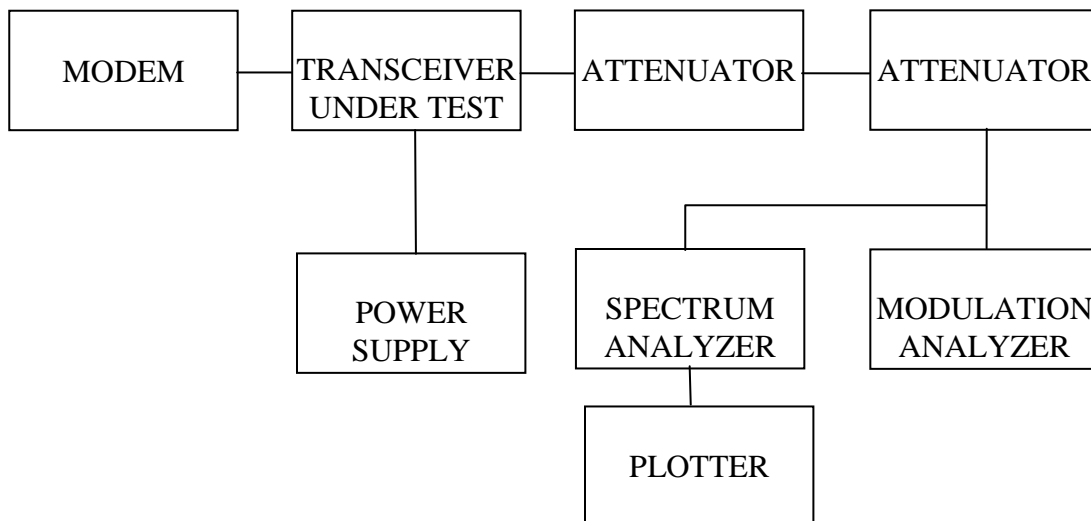

Mask: D, 1W
Output Power = 1 Watt

Spectrum for Emission: 8K50 F1D
Data Rate: 24 kbps Peak Deviation with Data: 3.725 kHz

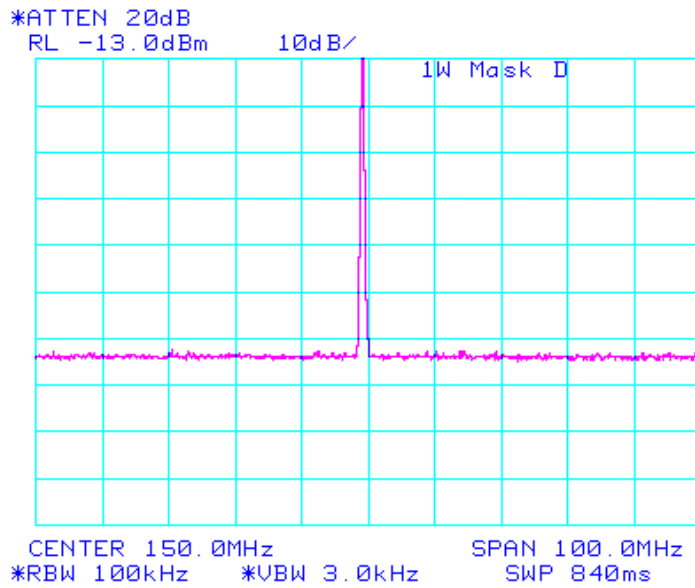
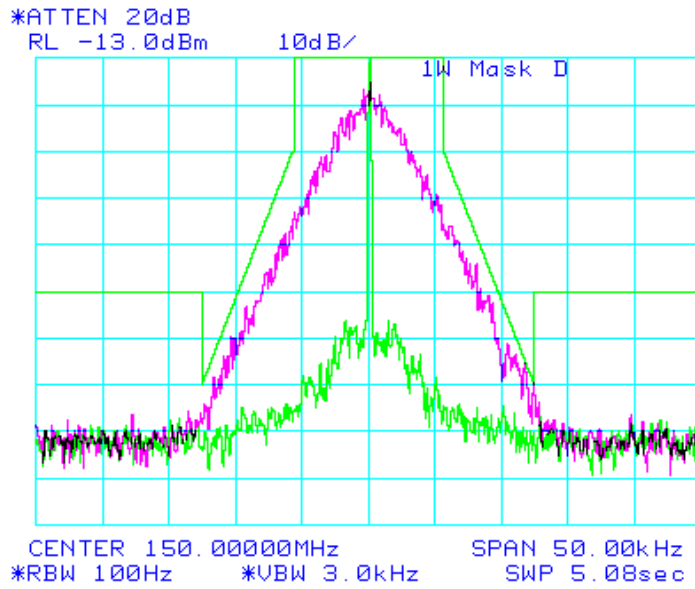

Output Power = 12 Watts

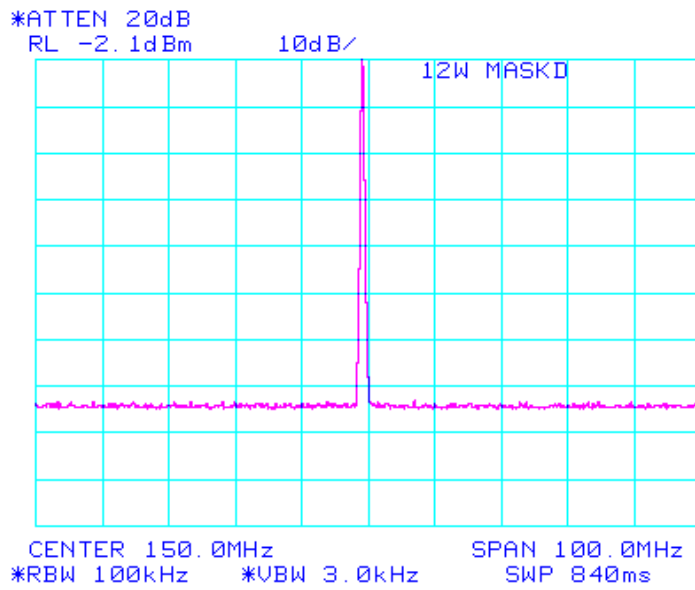
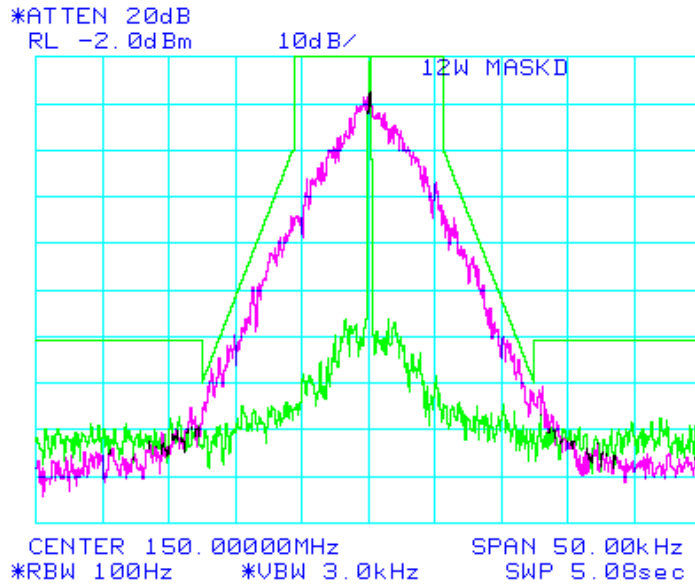

Mask: D, 1W
Output Power = 1 Watt

Spectrum for Emission: 8K08 F1D
Data Rate: 32 kbps Peak Deviation with Data: 3.728 kHz

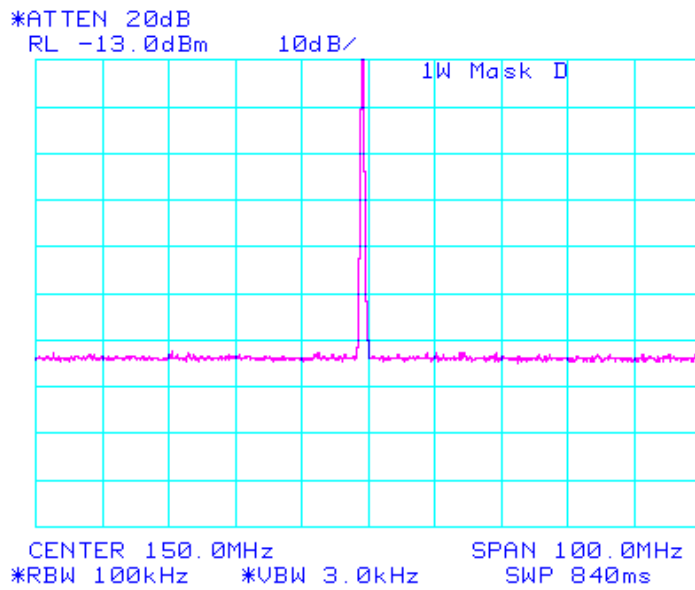
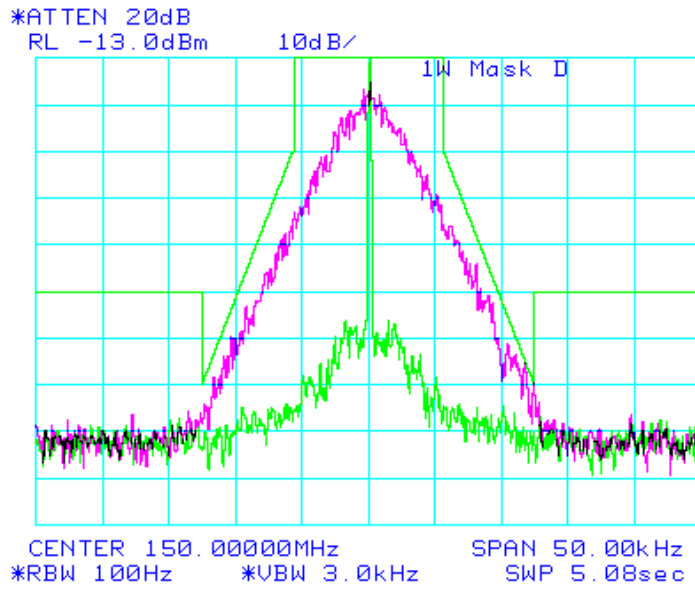

Output Power = 12 Watts

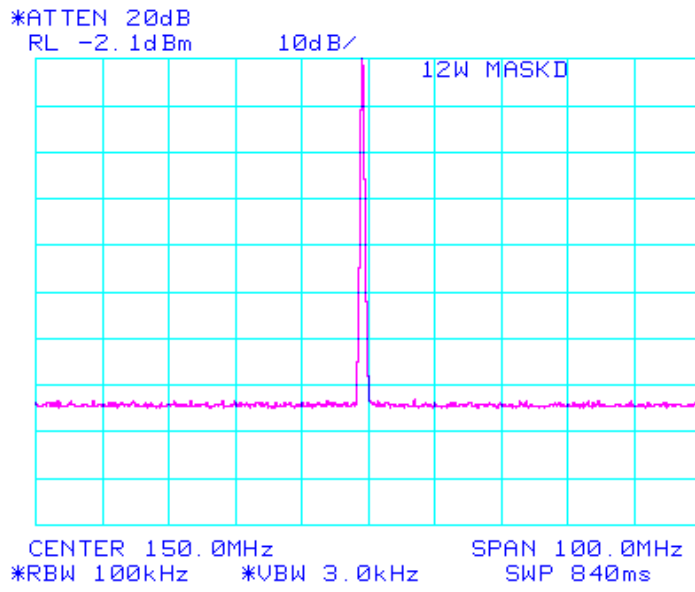
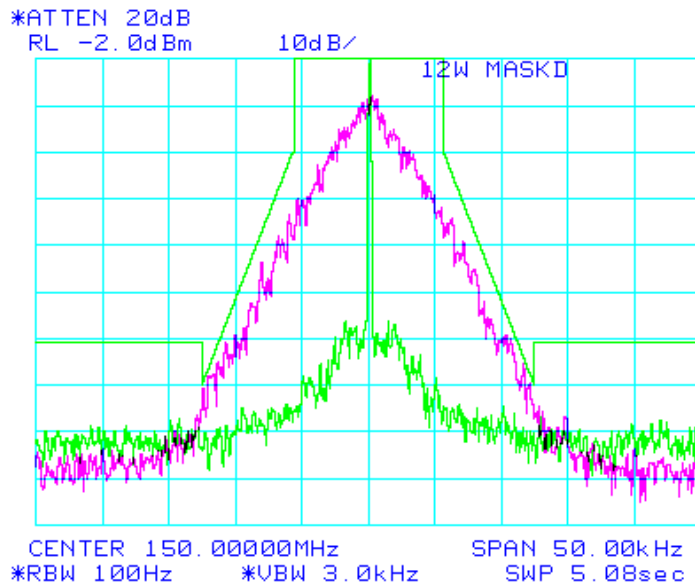

NAME OF TEST: Transmitter Occupied Bandwidth for Emission Designators **17K8F1D** and **17K0F1D**

RULE PART NUMBER: FCC: 2.202, 90.209 (b)(5), 90.210(c), 2.1049 (c) (1)
IC: RSS-119 5.8.2

MINIMUM STANDARDS: **Mask C**
Sidebands and Spurious [Rule 90.210 (c), 5.8.2, P = 12 Watts and P=1 Watt]
Authorized Bandwidth = 20 kHz [Rule 90.209(b) (5), 5.8.2]
From Fo to 5 kHz, down 0 dB.
Greater than 5 kHz to 10 kHz, down $83 * \log_{10}(f_d / 5)$ dB.
Greater than 10 kHz to 250% of authorized BW, at least $29 * \log_{10}(f_d^2 / 11)$ or 50 dB, whichever is the lesser attenuation
Greater than 250% of authorized BW, $43 + 10\log_{10}(P)$

Attenuation = 0 dB at Fo to 5 kHz
Attenuation = 25 dB at 10 kHz
Attenuation = 50 dB at 24.1 kHz
Attenuation = 50 dB at 50 kHz
Attenuation = 53.8 dB at frequencies greater than 50 kHz @ 12 W
Attenuation = 43 dB at frequencies greater than 50 kHz @ 1 W

TEST RESULTS: Meets minimum standards (see data on following page)

TEST CONDITIONS: Standard Test Conditions, 25 C
RF Power Level = 1 Watt and 12 Watts
Voltage = 20VDC

TEST PROCEDURE: TIA/EIA – 603-C

TEST EQUIPMENT: 50-Ohm Attenuator, Bird Electronics Model 50-A-FFN-20 (20dB, 50W)
50-Ohm Attenuator, Bird Electronics Model 10-A-MFN-10 (10dB, 10W)
50-Ohm Attenuator, Pasternack Model PE7002-10 (10dB)
DC Power Supply, Hewlett Packard Model 6653A
Spectrum Analyzer, Hewlett Packard Model HP8563E
Modulation Analyzer, Hewlett Packard Model HP8901A

TEST SET-UP:

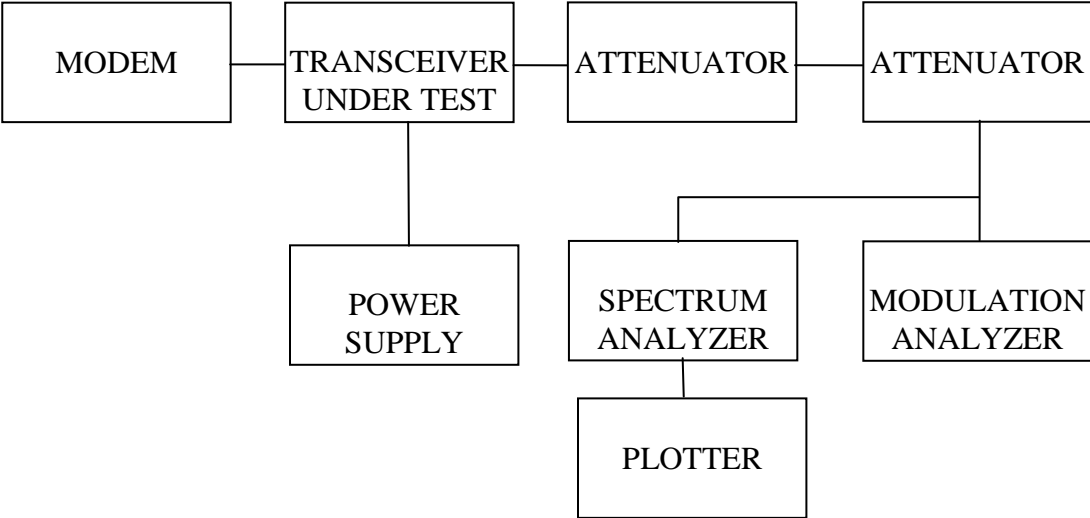

Mask: C, 1W
Output Power = 1 Watt

Spectrum for Emission: 17K8 F1D
Data Rate: 48 kbps Peak Deviation with Data: 7.59 kHz

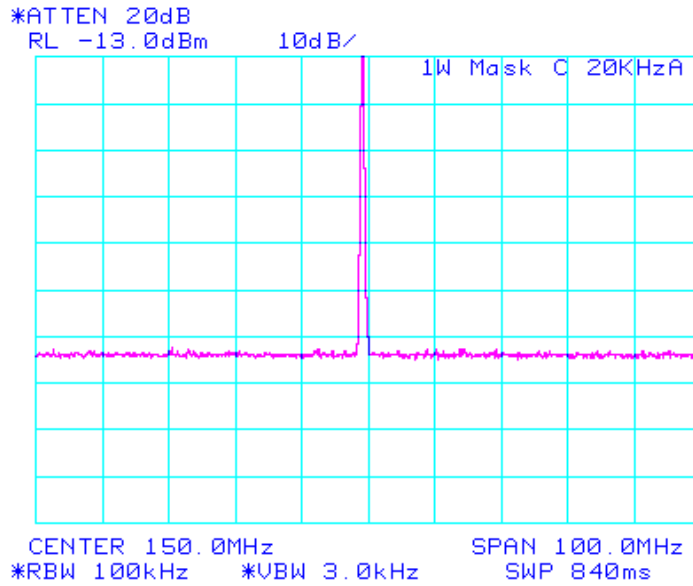
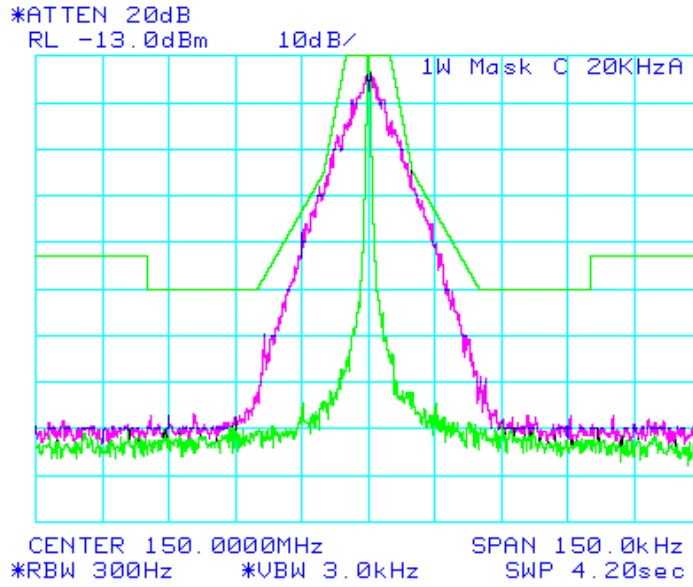

Output Power = 12 Watt

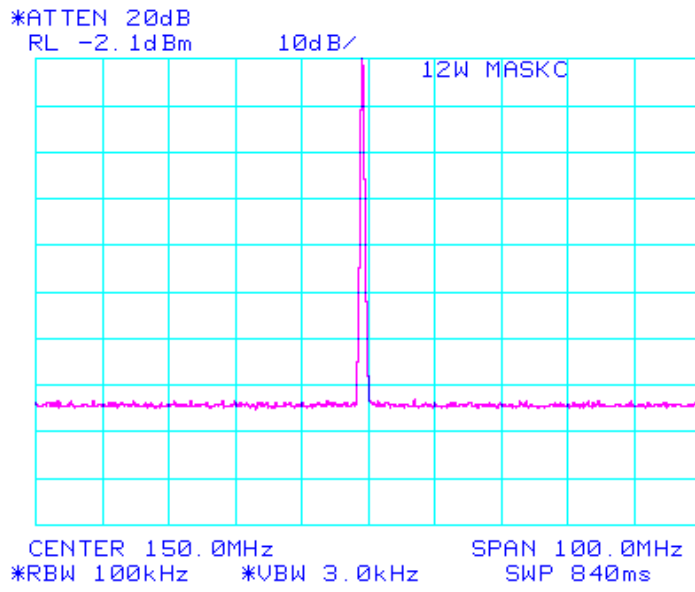
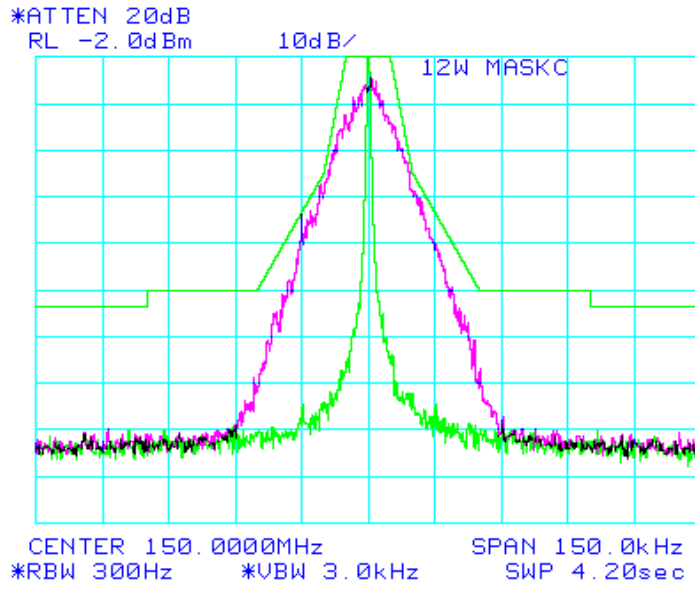

Mask: C, 1W
Output Power = 1 Watt

Spectrum for Emission: 17K0 F1D
Data Rate: 64 kbps Peak Deviation with Data: 7.52 kHz

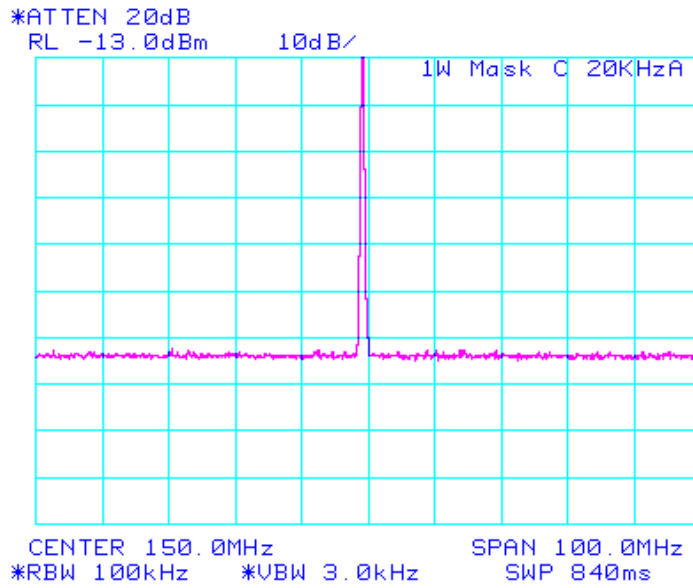
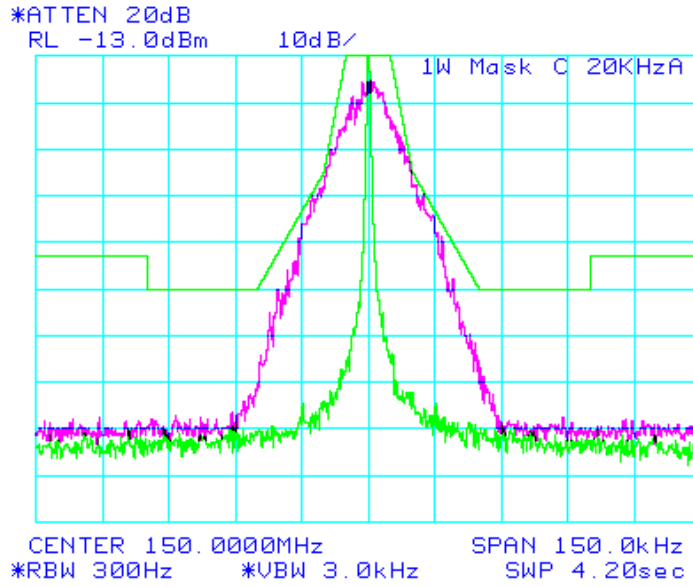

Output Power = 12 Watts

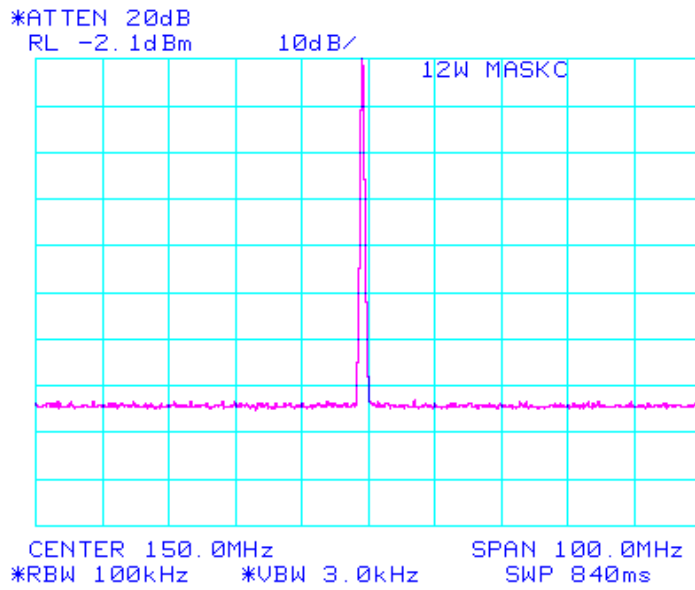
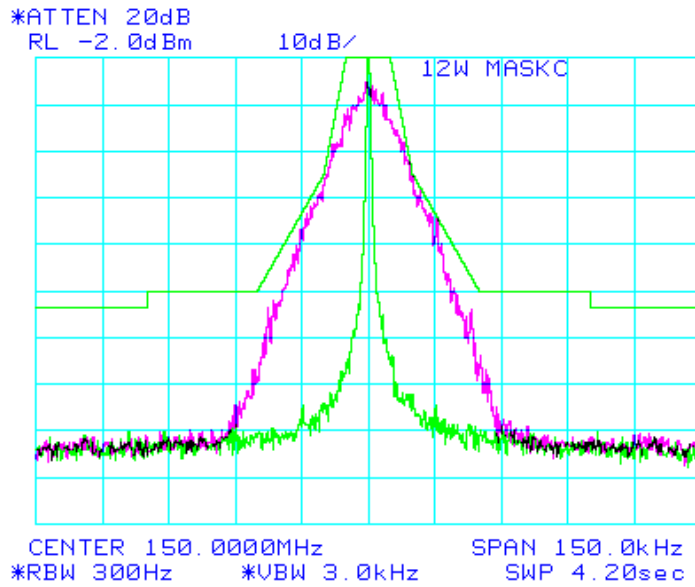

Equipment Calibration Information

| Equipment | Serial Number | Cal Date | Cal Due |
|---------------------------------|---------------|-----------|-----------|
| HP 8563E Spectrum Analyzer | 3221A00149 | 4/15/2010 | 4/15/2012 |
| Agilent E8257D Signal Generator | MY44320507 | 4/20/2010 | 4/20/2012 |
| HP 8901A Modulation Analyzer | 2950A05551 | 4/12/2010 | 4/12/2012 |
| HP 437B Power Meter | 3125U13882 | 4/12/2010 | 4/12/2012 |

Instruments have been calibrated using standards with accuracies traceable to NIST standards.