

Calamp Wireless networks Corporation
Corporate Headquarters and Manufacturing Operations
299 Johnson Avenue, Suite 110
Waseca, MN 56093-0833 USA
Phone: 507-833-8819
Fax: 507-833-6748

FCC Part 90 Certification Application

IC RSS-119 Certification Application

FCC Form 731

For The

**Guardian 100
VHF RADIO MODEM**

FCC ID: NP4-5016-500

IC ID: 773B-5016500

For a Class II Permissive Change

TABLE OF CONTENTS

	Page #
Test 6: Transmitter Occupied Bandwidth – Mask D	3
12.5 kHz Half Channel Mask D / Mask B	5
Calibration Information	18

NAME OF TEST: Transmitter Occupied Bandwidth

RULE PART NUMBER: FCC: 2.201, 2.202, 2.1033 (c)(14), 2.1049 (h), 2.1041;90.203(j)(3)
 IC: RSS-Gen 4.6.1

Necessary Bandwidth Measurement

This radio modem uses digital modulation signals, passing through a linear 8th order low-pass filter (Raise-Cosine alpha 1 approximation), to an FM transceiver. The necessary bandwidth calculation for this type of modulation (DRCMSK) is outlined in FCC: (2.202(c)(4)) and IC: TRC 43 section 7.

The measurement explanations are provided below.

Necessary Bandwidth Measurement:

Channel Spacing	Emission Type	Data Rate	Baud Rate	Measured Peak Deviation	Measured 99% Occupied BW
12.5 kHz	10K2F3D	NA	NA	2.438 kHz	10.2 kHz
12.5 kHz	10K2F3E	NA	NA	2.438 kHz	10.2 kHz

THEORY OF MEASUREMENT

The way to define the Occupied Bandwidth is “the frequency bandwidth such that, below its lower and above its upper frequency limits, the mean powers radiated are each equal to 0.5 percent of the total mean power radiated by a given emission” (FCC 2.202) (RSS-Gen 4.6.1), the mathematics are as follows:

$$0.005*TP=P_{(f1)}=\int_0^{f1} PSD_{(f)}df$$

$$0.995*TP=P_{(f2)}=\int_0^{f2} PSD_{(f)}df$$

$$OBW=f2-f1$$

where TP (total mean power) is

$$TP=\int_0^{+\infty} PSD_{(f)}df = (1/t) \int_{-\infty}^{+\infty} |z_{(t)}|^2 dt$$

and PSD (power spectral distribution) is

$$PSD_{(f)}=|Z_{(f)}|^2+|Z_{(-f)}|^2 \quad 0 \leq f < \infty$$

and expresses the positive frequency representation of the transmitter output power for z(t) signal.

By applying these mathematics to the measurements, it is possible to measure the Occupied Bandwidth using a digital spectrum analyzer.

The Occupied Bandwidth measurement is in two parts relatively independent of each other. The first gives the RF spectrum profile, and the second calculates the frequency limits and they result in the Occupied bandwidth. While the first involves RF measurement instrumentation, the second is strictly a computational part related to measured trace.

TEST EQUIPMENT:

50-Ohm Attenuator, Bird Electronics Model 50-A-FFN-20 (20dB, 50W)
50-Ohm Attenuator, Bird Electronics Model 25-A-MFN-6 (6dB, 25W)
DC Power Supply, Hewlett Packard Model 6653A
Spectrum Analyzer, Hewlett Packard Model HP8563E
Modulation Analyzer, Hewlett Packard Model HP8901B

TEST SET-UP:

For the above requirements, the occupied bandwidth of a transmitter was measured using an HP8563E using the following settings:
Occupied BW % Power: 99%
Trace: Max Hold A
RBW: 100 Hz (12.5 kHz channels)
VBW: 3 kHz
SPAN: 50 kHz (12.5 kHz channels)

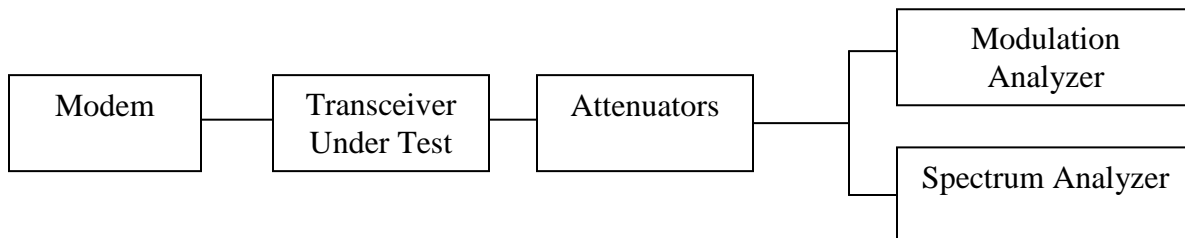

NAME OF TEST: Transmitter Occupied Bandwidth for Emission Designators
10K2F3D and **10K2F3E**

RULE PART NUMBER: FCC: 2.202, 90.209 (b)(5), 90.210(d), 2.1049 (c)(1)
IC: RSS-119 5.8.3

MINIMUM STANDARDS: **Mask D**
Sidebands and Spurious [Rule 90.210 (d), 5.8.3, P = 12 Watts, P = 2 Watts and P = 1 Watt]
Authorized Bandwidth = 11.25 kHz [Rule 90.209(b) (5), 5.8.3]
From f_0 to 5.625 kHz, down 0 dB.
Greater than 5.625 kHz to 12.5 kHz, down $7.27(f_d - 2.88\text{kHz})$ dB.
Greater than 12.5 kHz, at least $50 + 10\log_{10}(P)$ or 70 dB, whichever is the lesser attenuation.

Attenuation = 0 dB at f_0 to 5.625 kHz
Attenuation = 20 dB at 5.625 kHz and 70 dB at 12.5 kHz
Attenuation = 60.8 dB at frequencies greater than 12.5 kHz @ 12 W
Attenuation = 50 dB at frequencies greater than 12.5 kHz @ 1 W

TEST RESULTS: Meets minimum standards (see data on following page)

TEST CONDITIONS: Standard Test Conditions, 25 C
RF Power Level = 1 Watt and 12 Watts
Voltage = 20VDC

TEST PROCEDURE: TIA/EIA – 603-C

TEST EQUIPMENT: 50-Ohm Attenuator, Bird Electronics Model 50-A-FFN-20 (20dB, 50W)
50-Ohm Attenuator, Bird Electronics Model 25-A-MFN-6 (6dB, 25W)
DC Power Supply, Hewlett Packard Model 6653A
Spectrum Analyzer, Hewlett Packard Model HP8563E
Modulation Analyzer, Hewlett Packard Model HP8901B

TEST SET-UP:

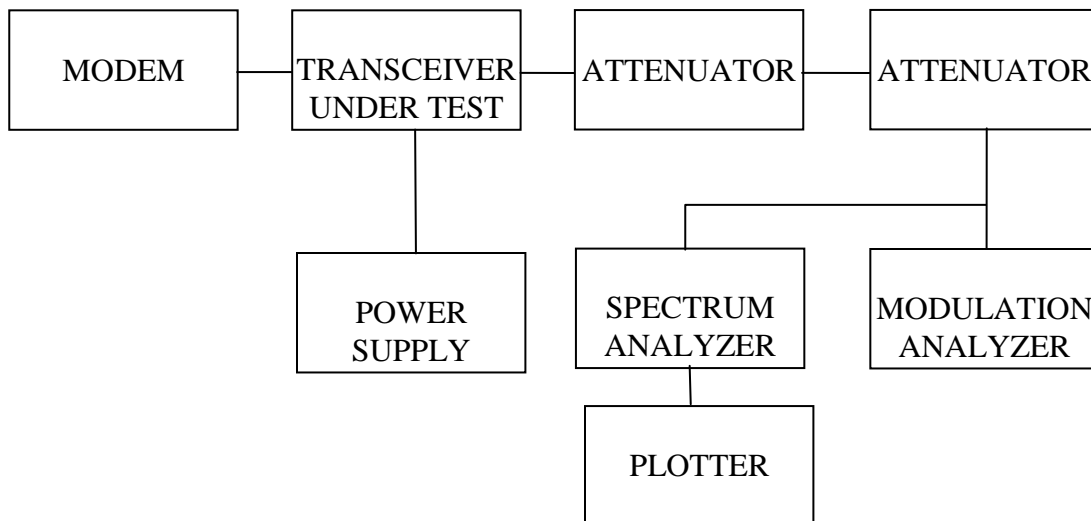

Mask: D, 1W
Output Power = 1 Watt

Spectrum for Emission: 10K2F3D
Peak Deviation with Data: 2.438 kHz

Mask B = Black Line
Mask D = Green Line

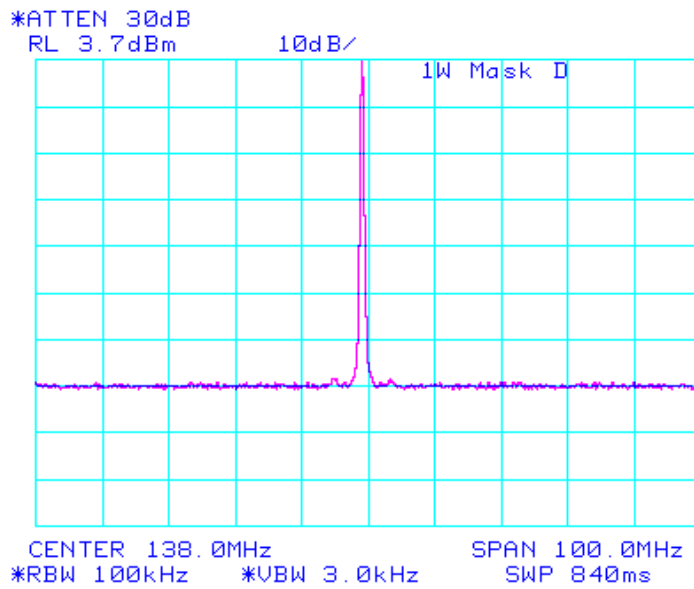
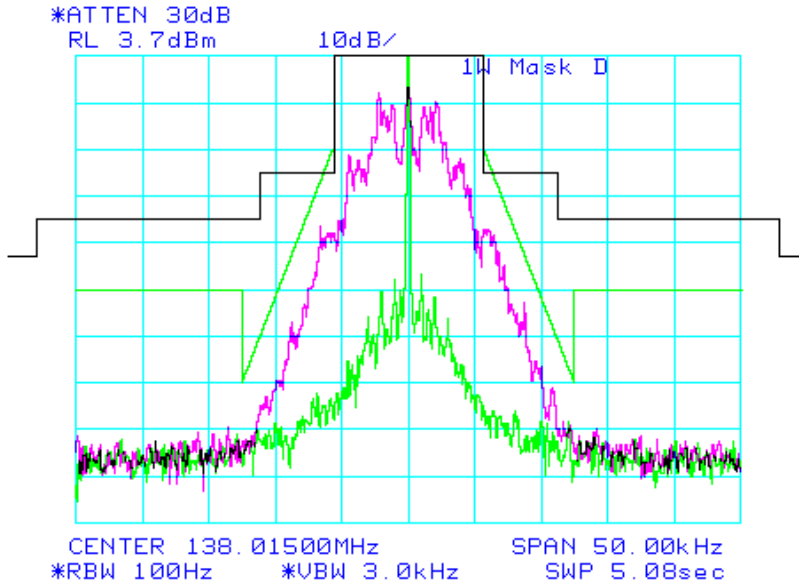

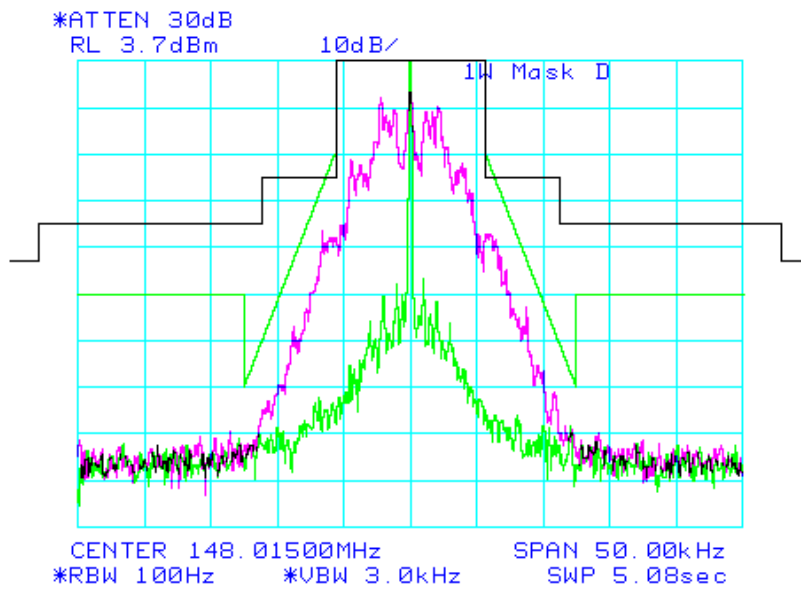
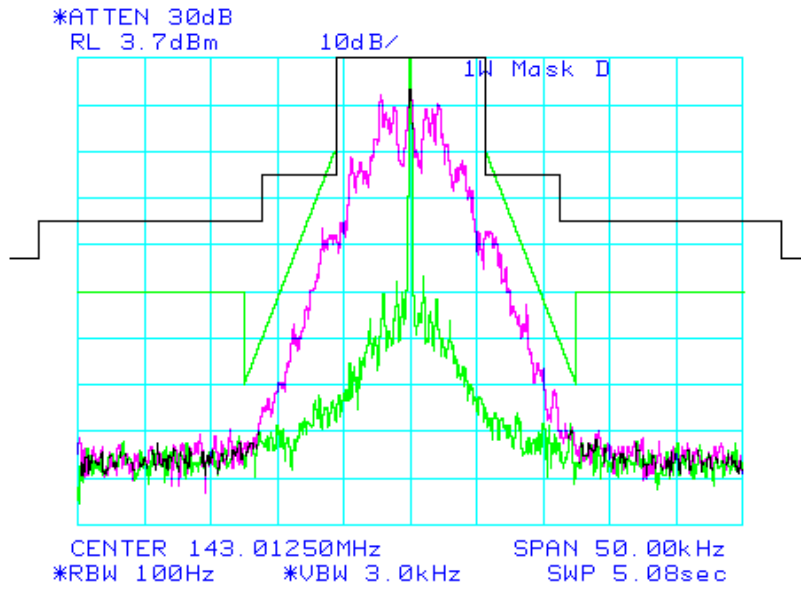

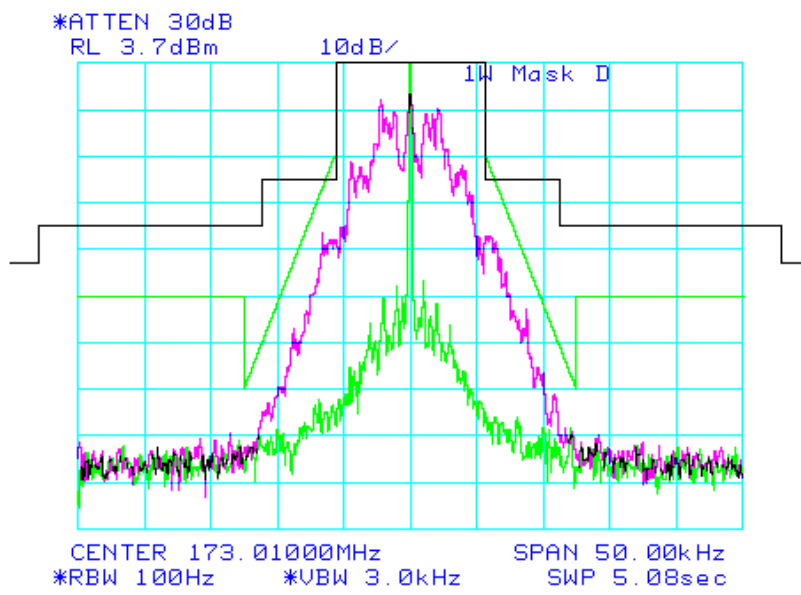
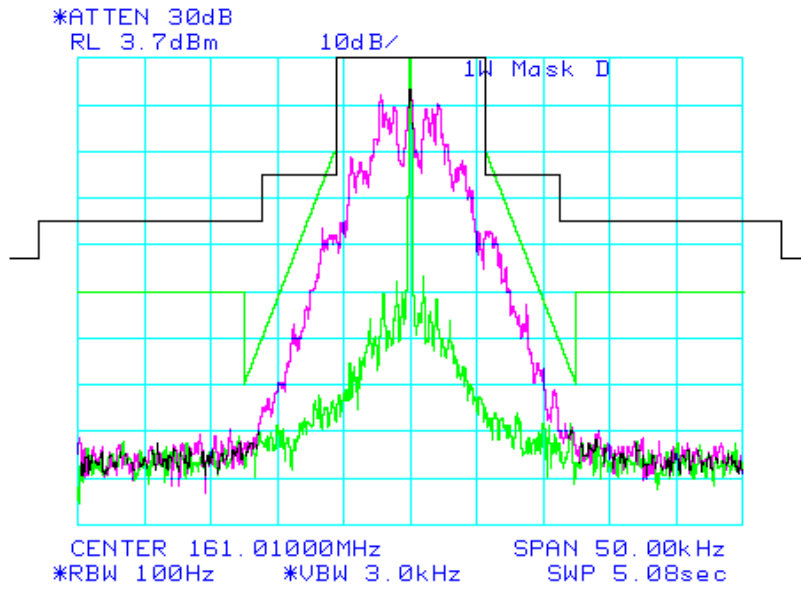

Output Power = 12 Watts

Mask B = Black Line

Mask D = Green Line

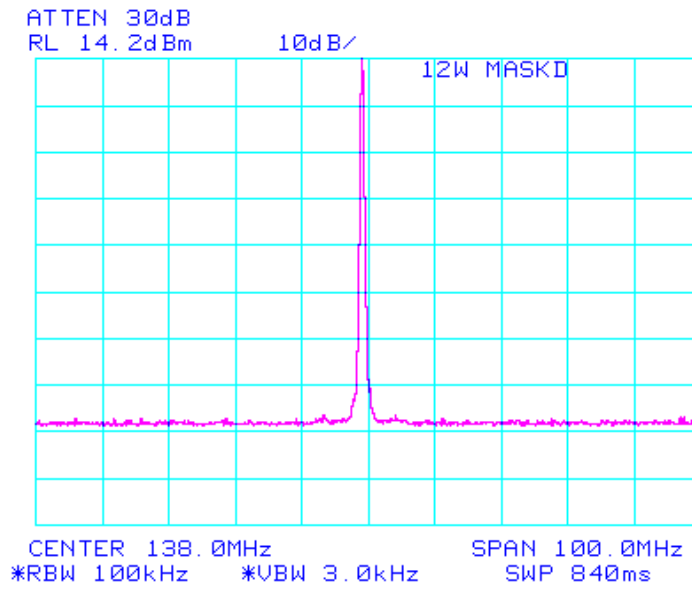
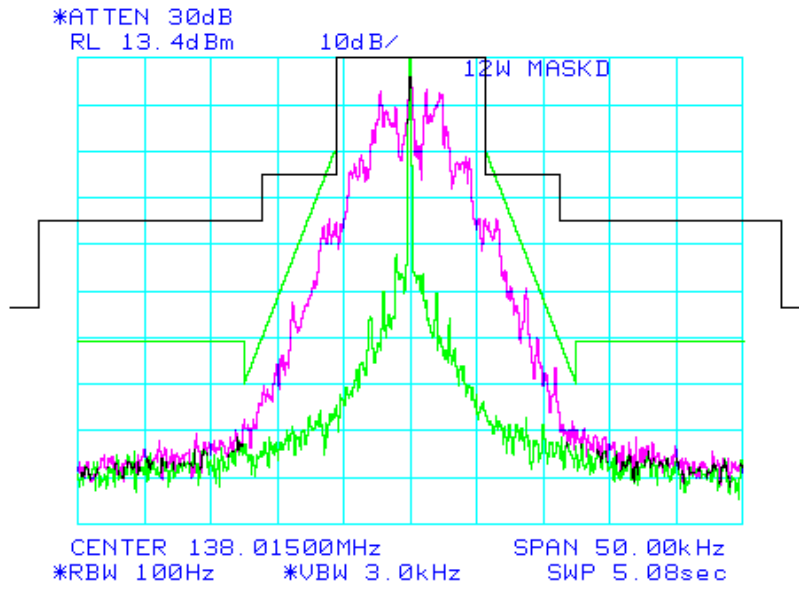

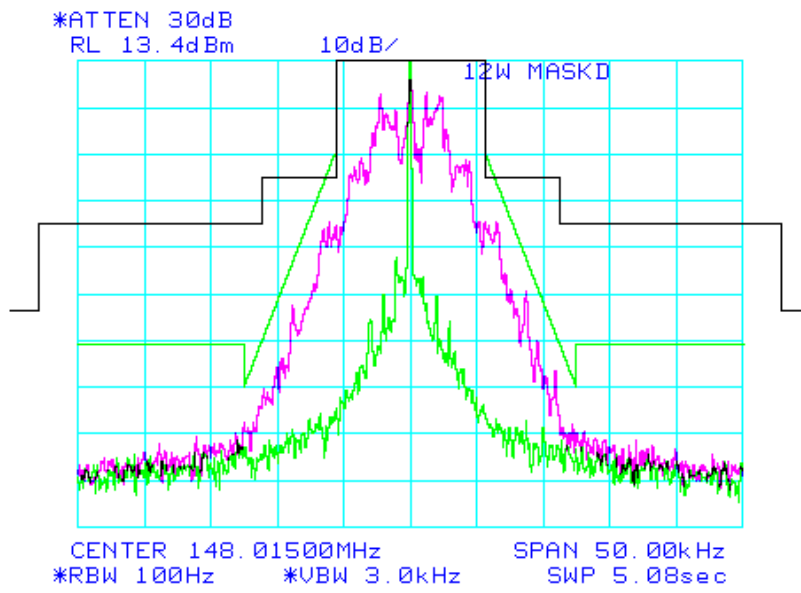
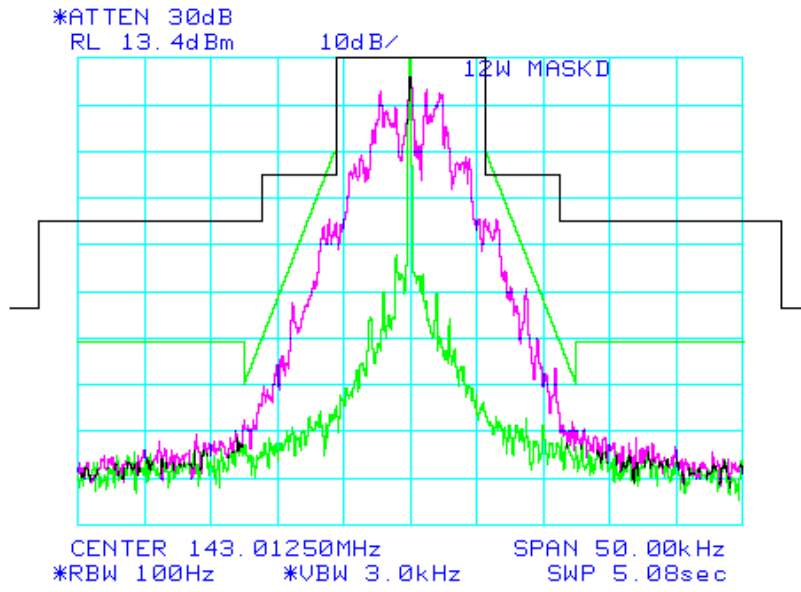

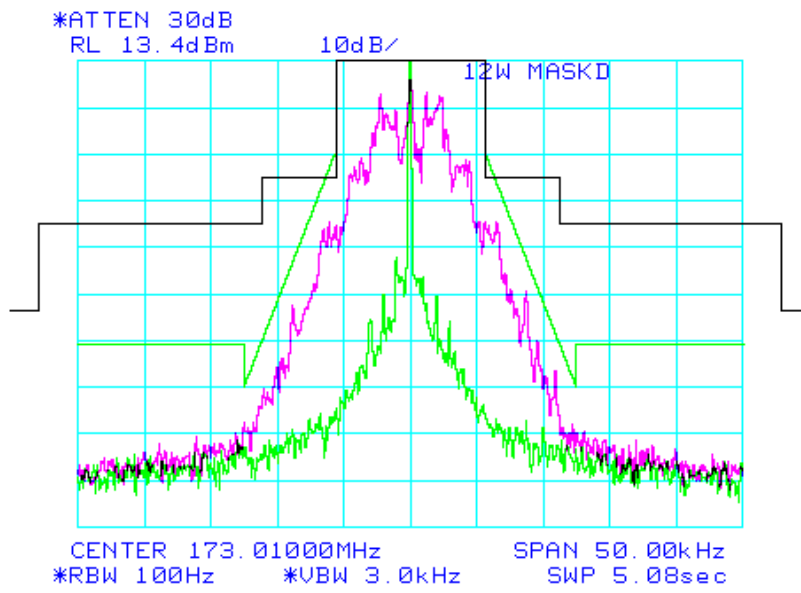
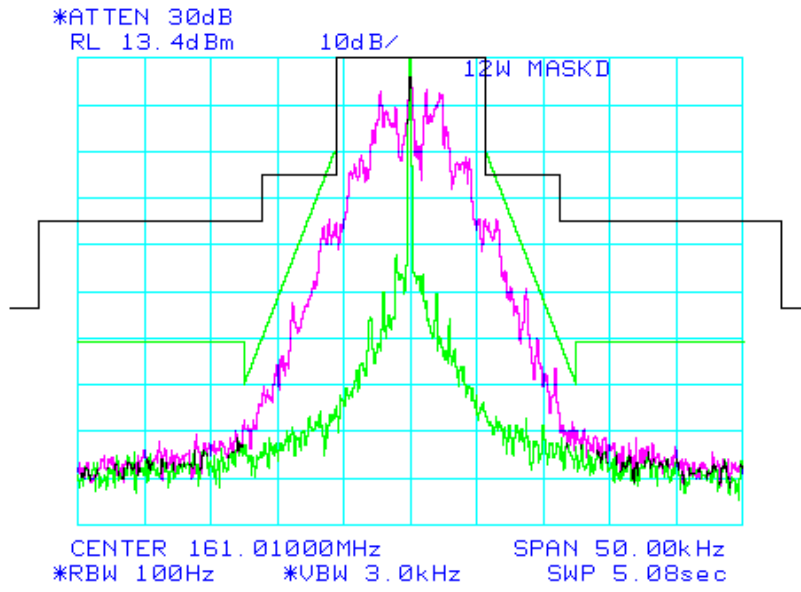

Mask: D, 1W
Output Power = 1 Watt

Spectrum for Emission: 10K2F3E
Peak Deviation with Data: 2.438 kHz

Mask B = Black Line
Mask D = Green Line

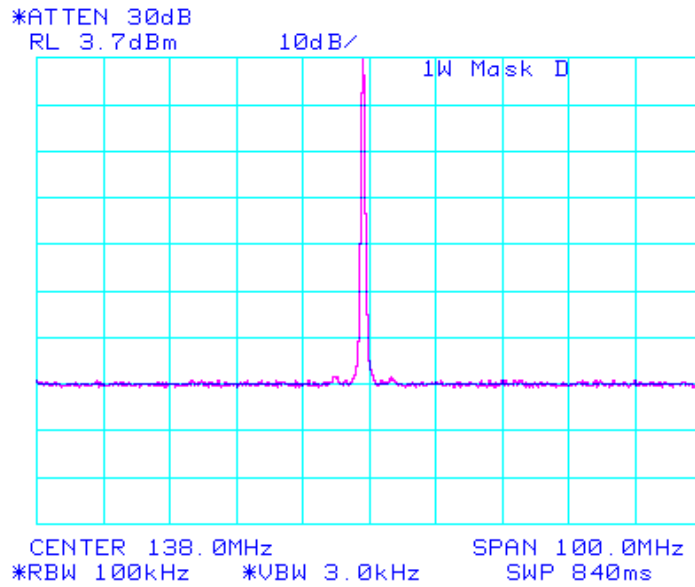
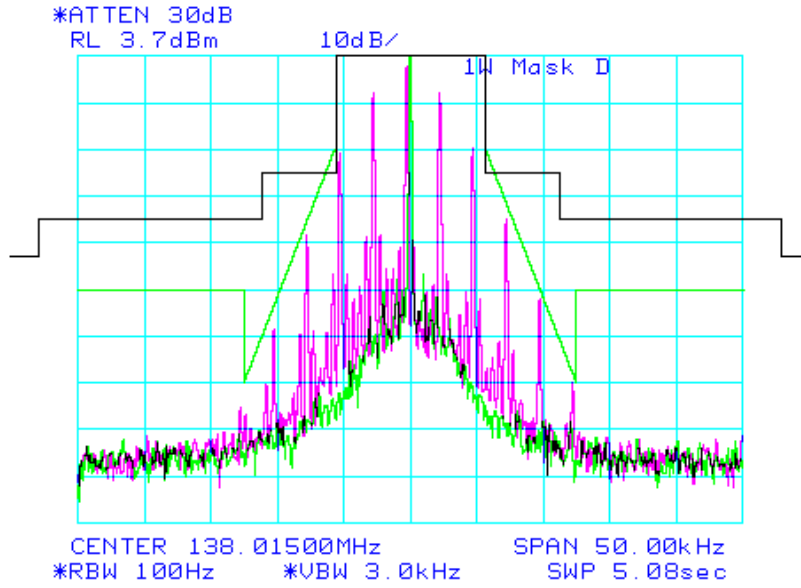

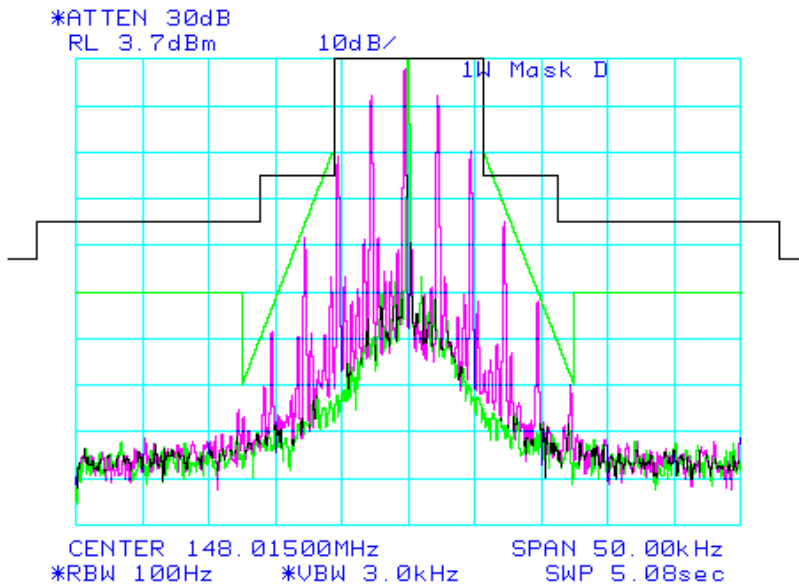
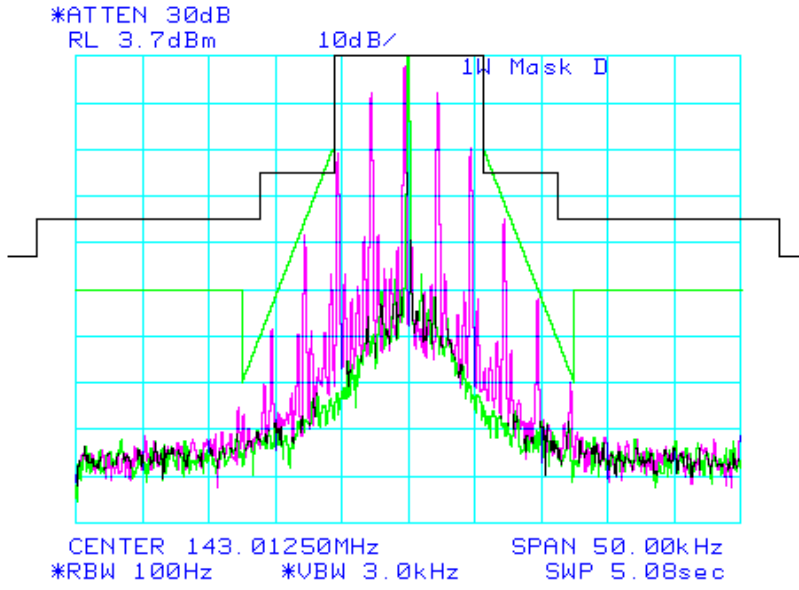

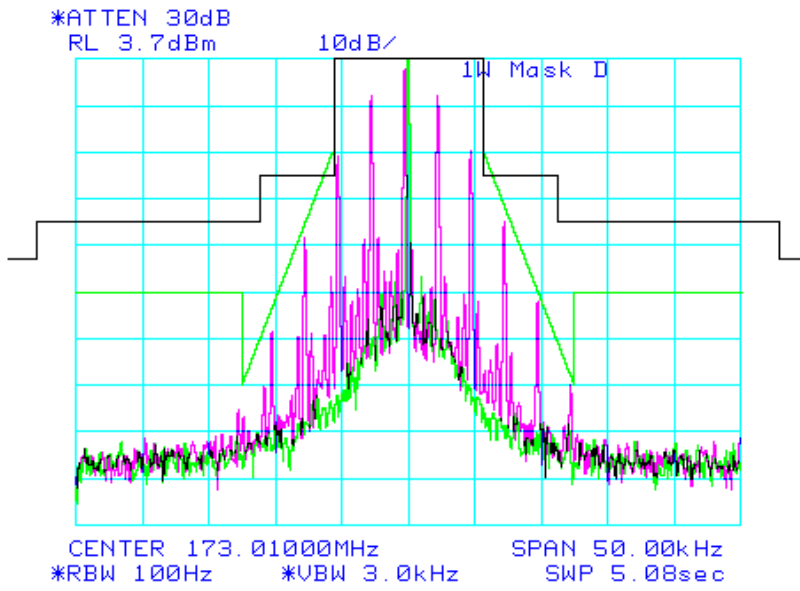
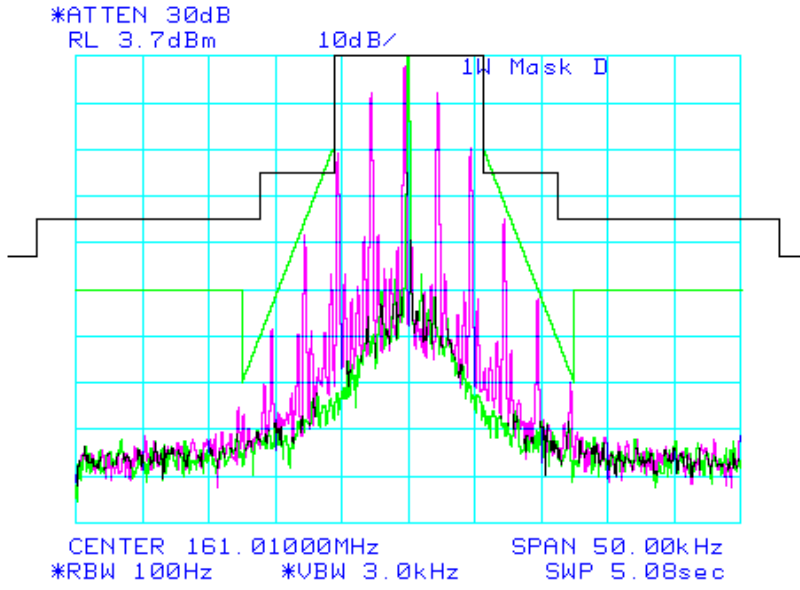

Output Power = 12 Watts

Mask B = Black Line

Mask D = Green Line

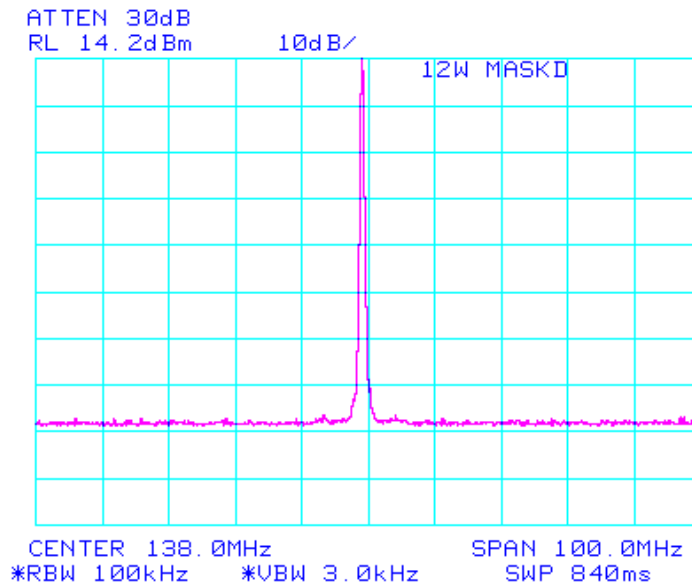
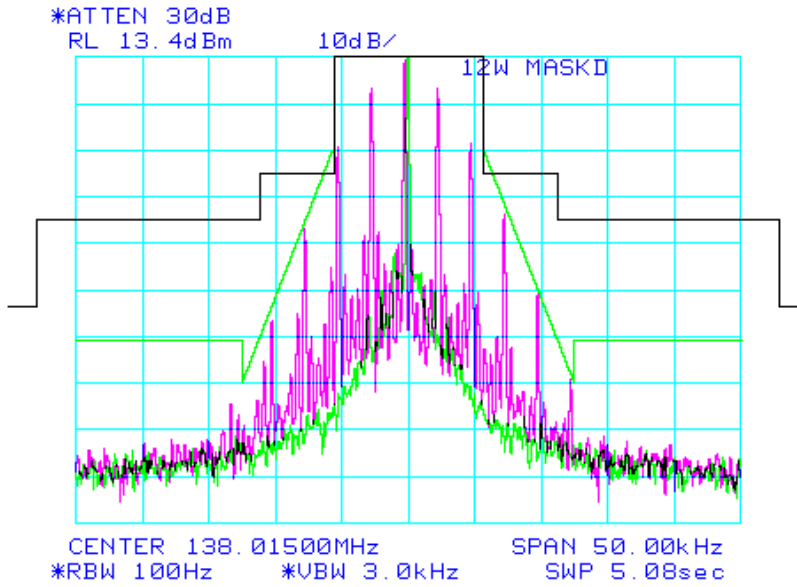

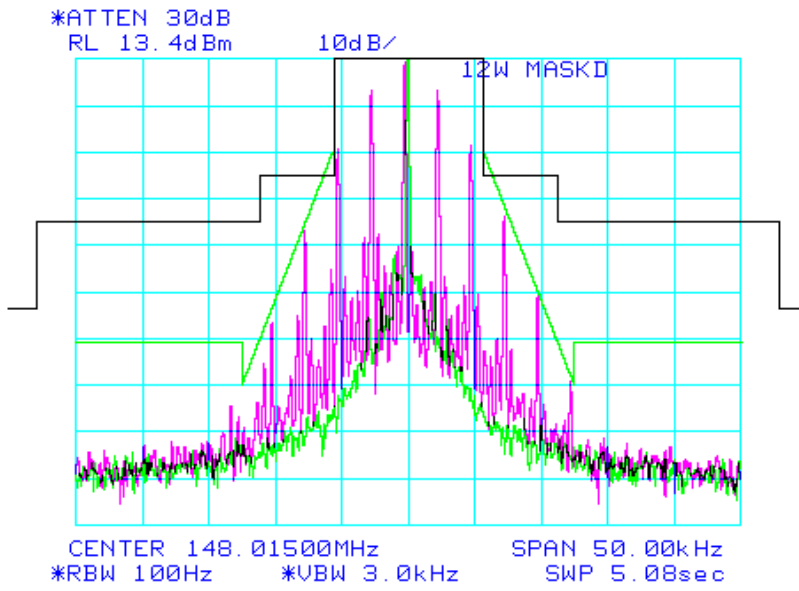
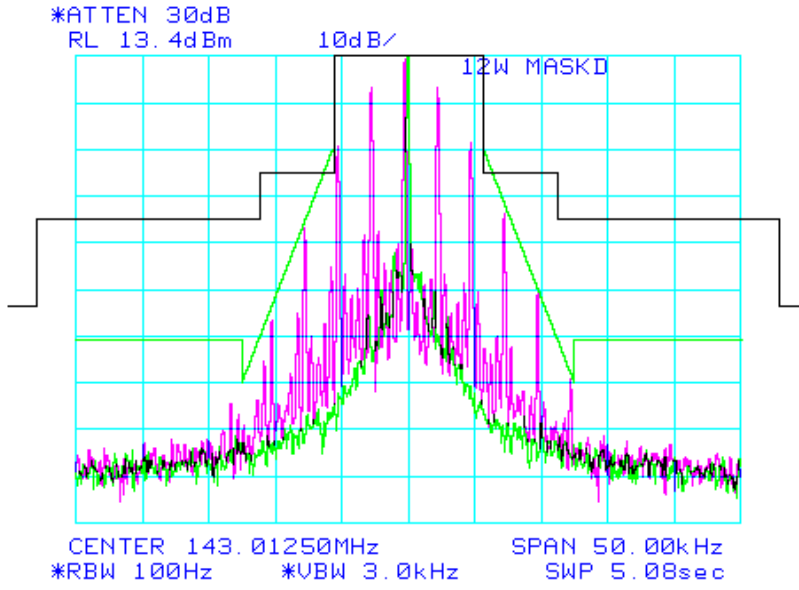

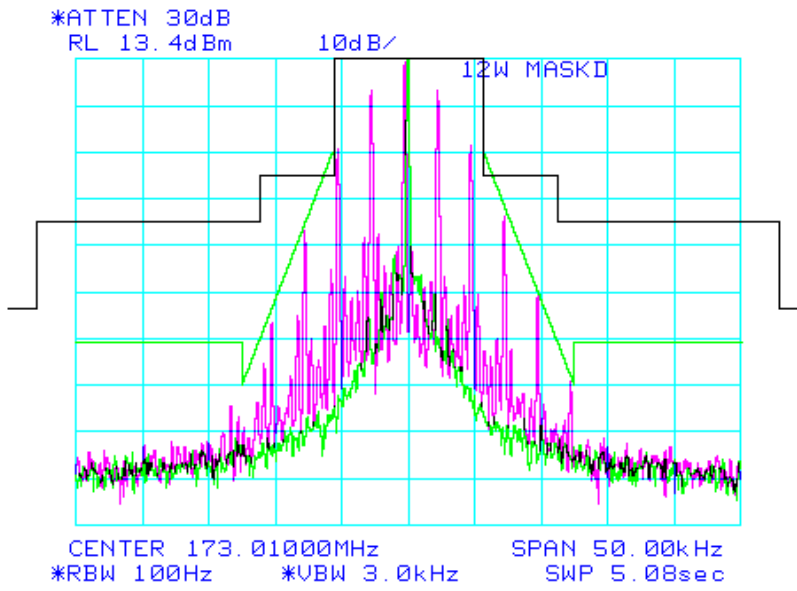
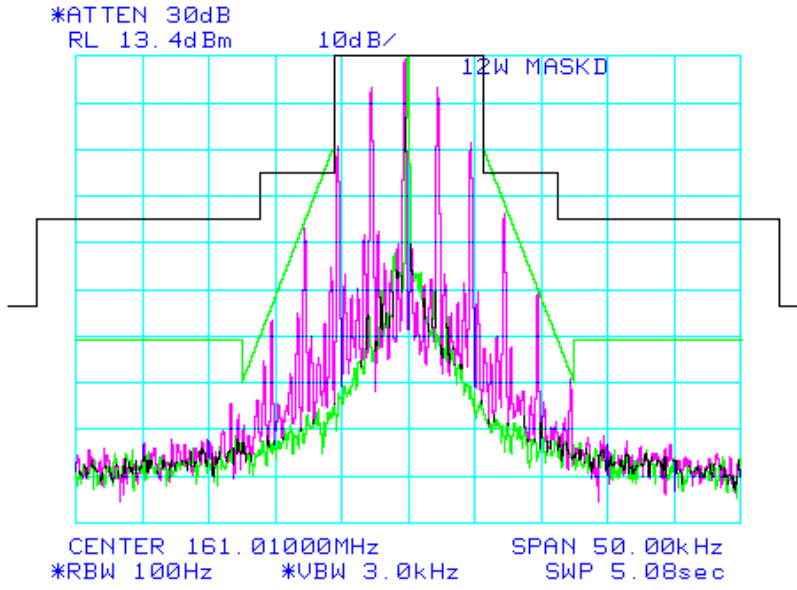

Equipment Calibration Information

Equipment	Serial Number	Cal Date	Cal Due
HP 8563E Spectrum Analyzer	3221A00149	4/15/2010	4/15/2012
Agilent E8257D Signal Generator	MY44320507	4/20/2010	4/20/2012
HP 8901A Modulation Analyzer	2950A05551	4/12/2010	4/12/2012
HP 437B Power Meter	3125U13882	4/12/2010	4/12/2012

Instruments have been calibrated using standards with accuracies traceable to NIST standards.