

DATARADIO COR Ltd.  
Corporate Headquarters and Manufacturing Operations  
299 Johnson Avenue, Suite 110  
Waseca, MN 56093-0833 USA  
Phone: 507-833-8819  
Fax: 507-833-6748

**FCC Part 90 Certification Application**

**FCC Form 731**

**For The**

**JSLM<sup>2</sup>**

**VHF ANALOG TELEMETRY RADIO MODEM**

**FCC ID: NP4-2422110610**



TABLE OF CONTENTS

Test 1: Transmitter Rated Output Power

Test 2: Frequency Response of Transmitter Audio Low Pass Filter

Test 3: Audio Frequency Response of Transmitter Modulating Circuit

Test 4: Modulation Limiting

Test 5: Transmitter Occupied Bandwidth - Mask D

Test 6: Transmitter Spurious and Harmonic Output

Test 7: Frequency Stability with Variation in Ambient Temperature

Test 8: Field Strength of Spurious Radiation

Test 9: Frequency Stability with Variation in Supply Voltage

Test 10: Transient Frequency Behavior

NAME OF TEST: Transmitter Rated Power Output

RULE PART NUMBER: 2.1046 (a) (c)

TEST RESULTS: See results below

TEST CONDITIONS: Standard Test Conditions

TEST EQUIPMENT: 50 Ohm Attenuator, Tenuline Model 8340 / 20 dB / 25 Watt  
 50 Ohm Attenuator, Tenuline Model 8340 / 10dB / 25 Watt  
 Power Supply, Instek Model GPS-2303  
 Power Meter, Model HP-436A

TEST SET-UP:

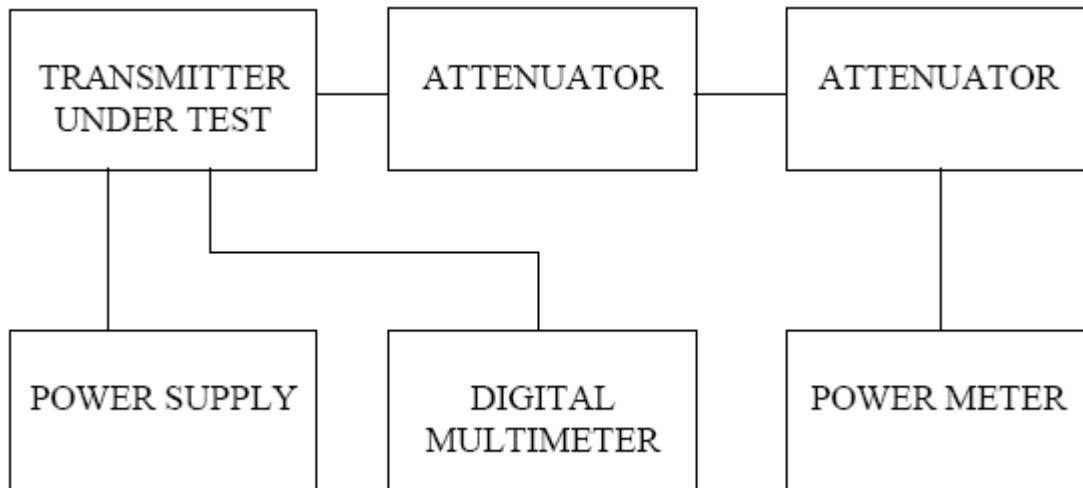

TEST RESULTS:

Frequency ( MHz )	DC Voltage at Final ( Vdc )	DC Current into Final ( Adc )	DC Power into Final ( W )	RF Power Output ( W )
150	12.50	1.24	15.50	5.0
150	7.20	0.61	4.39	0.1

NAME OF TEST: Frequency Response of Transmitter Audio Low pass Filter

RULE PART NUMBER: 2.1047(a)

TEST RESULTS: See Graph On Following Page

TEST CONDITIONS: Standard Test Conditions, 25 C

TEST PROCEDURE: TIA/EIA – 603-B, 2.2.15

TEST EQUIPMENT: Audio Generator, Model HP8903A  
Audio Analyzer, Model HP8903A

TEST SET-UP: TRANSMIT AUDIO SPLATTER FILTER

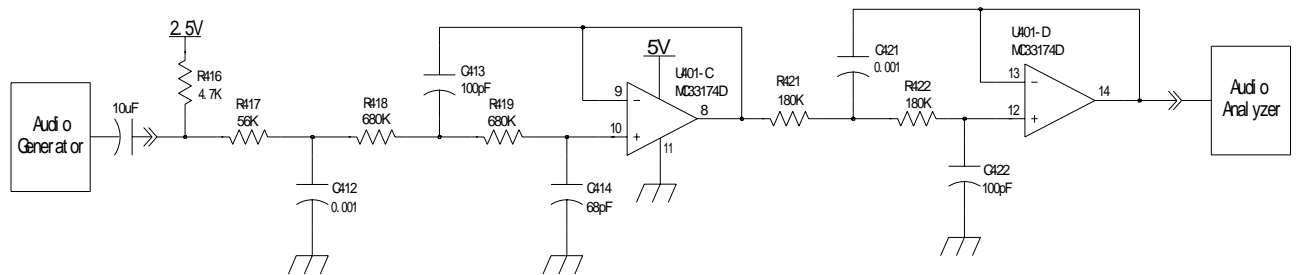

TEST RESULTS:

Performance Relative To 1000 Hz, 0 dB

Frequency (Hz)	Response (dB)
100	0.30
500	0.24
700	0.16
1000	0.00
1400	-0.25
2000	-0.82
2400	-1.80
3000	-5.96
3400	-10.20
4000	-16.65
4400	-20.60
5000	-26.00
7000	-40.50
9000	-51.50
10000	-56.30
15000	-75.00
20000	-83.40
30000	-84.40
50000	-85.30
70000	-84.70
80000	-83.90
100000	-84.20

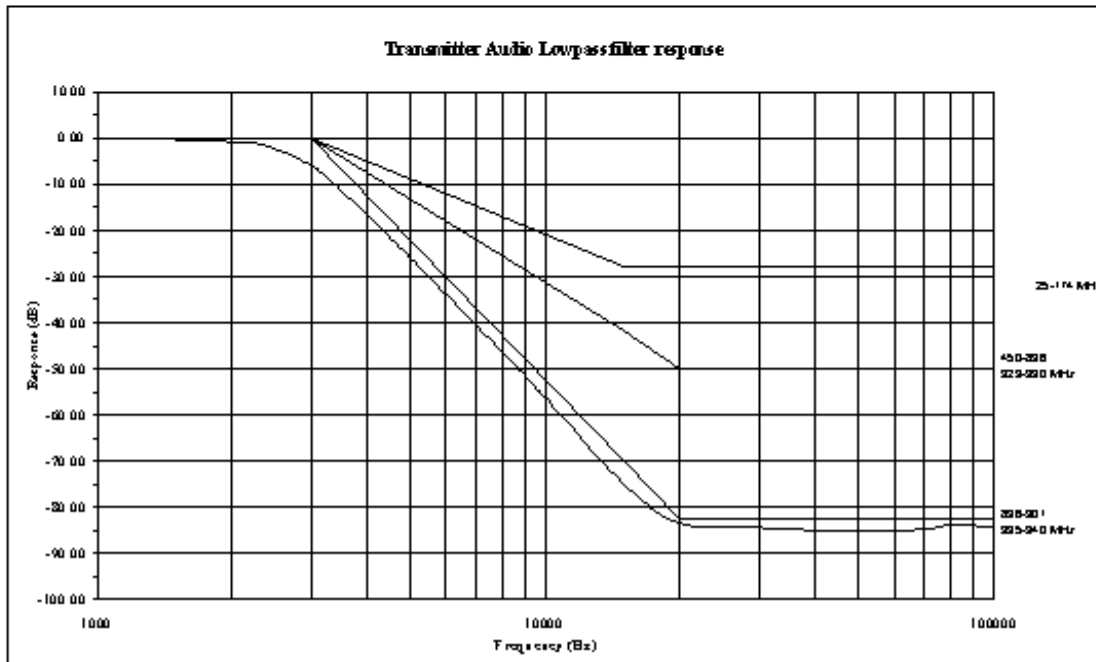

NAME OF TEST: Audio Frequency Response of Transmitter Modulating Circuit

RULE PART NUMBER: 2.1047 (a)

TEST RESULTS: Conforms to minimum standards, see following pages

TEST CONDITIONS: Standard Test Conditions, 25 C

TEST PROCEDURE: TIA/EIA – 603-B, 2.2.6.2.2

TEST EQUIPMENT: 50-Ohm Attenuator, Tenuline Model 8340 / 20 dB / 25 Watt  
 50-Ohm Attenuator, Tenuline Model 8340 / 10 dB / 25 Watt  
 Modulation Analyzer, Model HP8901A  
 Power Supply, Model Instek GPS-2303  
 Digital Voltmeter, Fluke Model 8000A  
 Audio Generator, Model HP8903A  
 Audio Voltmeter, Model HP8903A

TEST SET-UP:

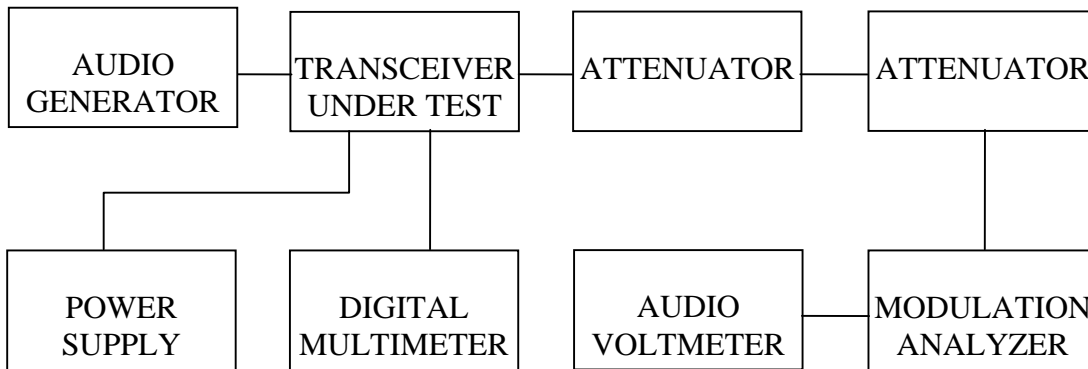

Reference level (0 dB) = 1.0 kHz deviation with 1000 Hz tone at audio input of loader board.

### MIC IN

Frequency (Hz)	Relative Level (dB)
100	-19.24
200	-13.98
300	-11.29
400	-8.79
500	-7.20
600	-4.18
700	-2.99
800	-1.94
900	-0.83
1000	0.00
1200	1.45
1400	2.58
1600	3.47
1800	4.28
2000	4.75
2500	5.02
3000	2.58
3500	-1.37
4000	-5.26
4500	-8.36
5000	-11.29

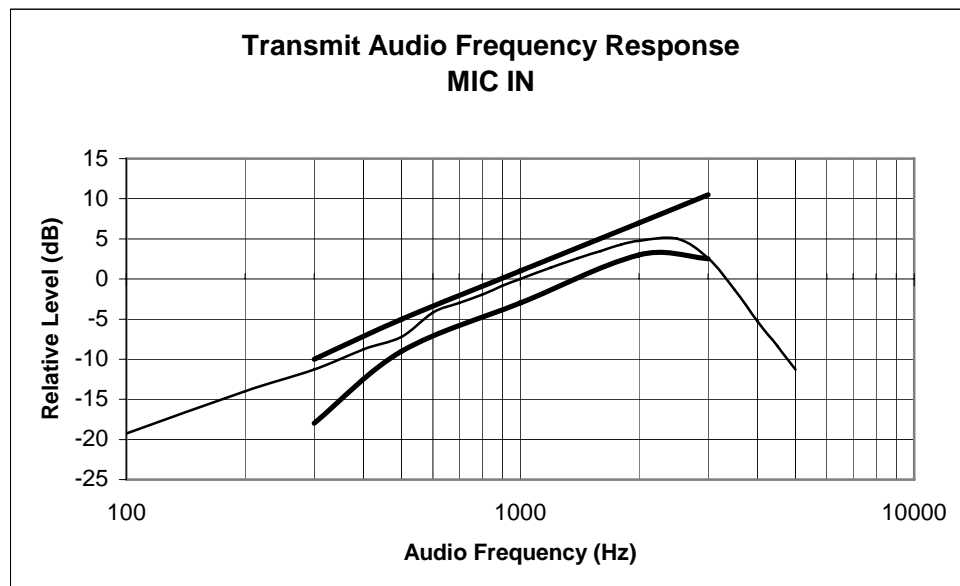

Reference level (0 dB) = 1.0 kHz deviation with 1000 Hz tone at audio input of loader board.

**AUX w/o Pre-emphasis**

Frequency (Hz)	Relative Level (dB)
100	-1.51
200	-0.35
300	0.00
400	-0.35
500	0.34
600	0.34
700	0.51
800	0.34
900	0.00
1000	0.00
1200	0.17
1400	-0.18
1600	-0.18
1800	-0.35
2000	-0.35
2500	-1.94
3000	-5.04
3500	-8.87
4000	-12.40
4500	-13.98
5000	-15.92

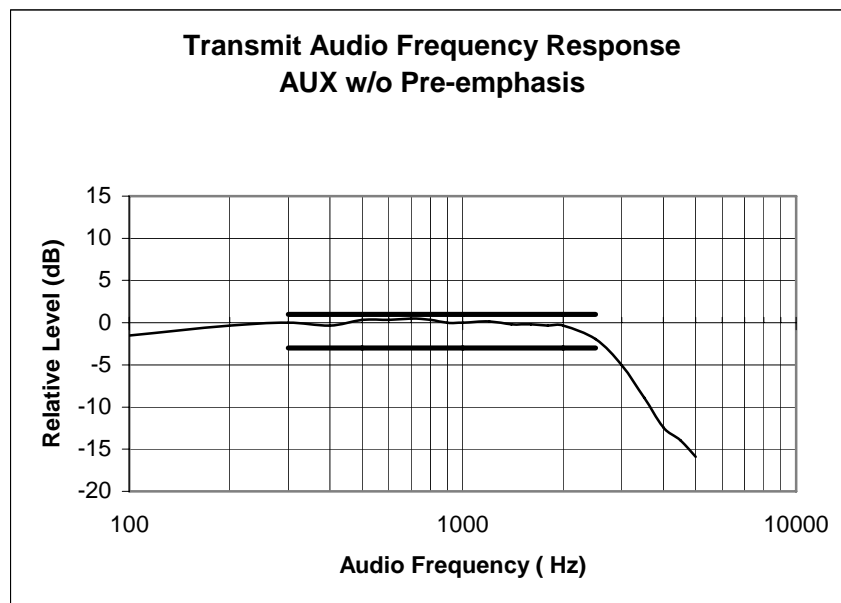



Reference level (0 dB) = 1.0 kHz deviation with 1000 Hz tone at audio input of loader board.

#### AUX with Pre-emphasis

Frequency (Hz)	Relative Level (dB)
100	-27.96
200	-17.08
300	-11.70
400	-7.96
500	-5.68
600	-3.88
700	-2.62
800	-1.72
900	-0.54
1000	0.00
1200	1.14
1400	2.54
1600	3.29
1800	3.86
2000	4.30
2500	4.71
3000	2.41
3500	-1.51
4000	-5.68
4500	-8.87
5000	-11.70

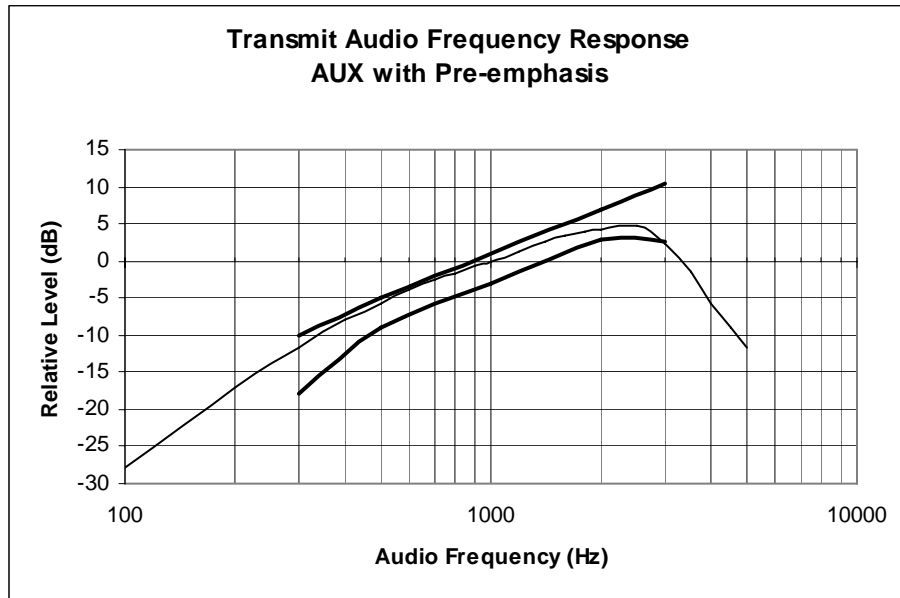

NAME OF TEST: Modulation Limiting

RULE PART NUMBER: 2.1047(b)

MINIMUM STANDARD: Shall not exceed 2.5 kHz deviation from 300 Hz to 3000 Hz

TEST RESULTS: Conforms to minimum standards

TEST CONDITIONS: Standard Test Conditions, 25 C

TEST PROCEDURE: TIA/EIA – 603-B, 2.2.3

TEST EQUIPMENT: 50 Ohm Attenuator, Tenuline Model 8340 / 20 dB / 25 Watt  
 50 Ohm Attenuator, Tenuline Model 8340 / 10 dB / 25 Watt  
 Modulation Analyzer, Model HP8901A  
 Power Supply, Model Instek GPS-2303  
 Digital Voltmeter, Fluke Model 8000A  
 Audio Generator, Model HP8903A  
 Audio Voltmeter, Model HP8903A

TEST SET-UP:

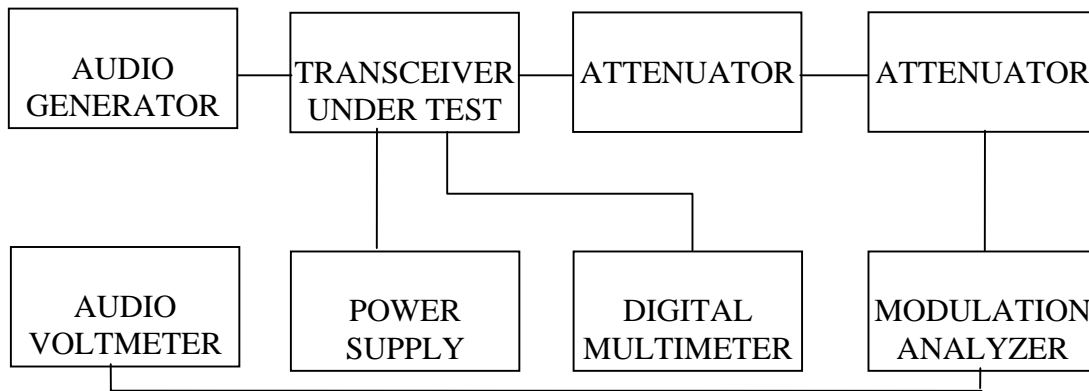

DEVIATION LIMITING WITH INPUT VOLTAGE  
20 dB ABOVE 60% RATED DEVIATION AT 300 Hz

For 11K0F3E

**MIC IN**

Mod. Freq Hz	Pos Dev (kHz)	Neg Dev (kHz)
100	1.85	1.89
200	1.94	2.10
300	2.10	2.26
400	2.25	2.11
500	2.20	1.76
800	2.20	1.59
1000	2.17	1.53
1500	2.33	1.50
2000	2.07	1.46
2500	1.74	1.60
3000	1.15	1.16
4000	0.37	0.40
5000	0.18	0.25

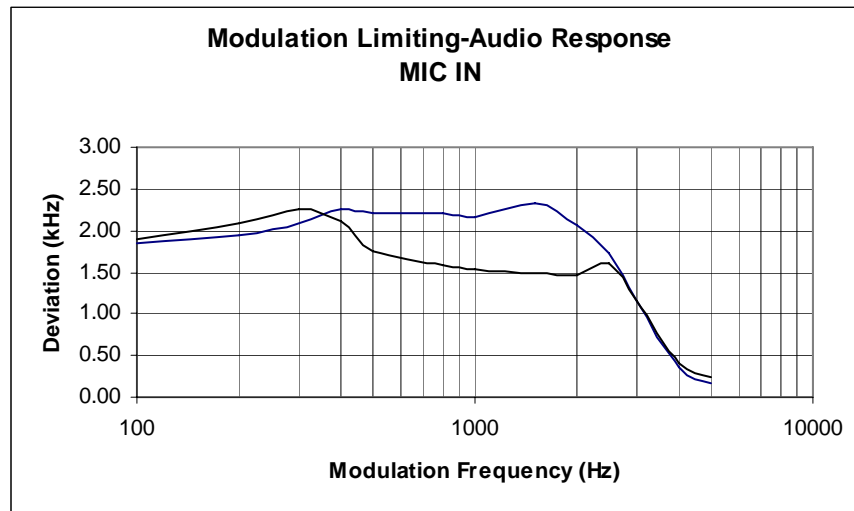

DEVIATION LIMITING WITH INPUT VOLTAGE  
20 dB ABOVE 60% RATED DEVIATION AT 1000 Hz

For 11K0F3E

**MIC IN**

Mod. Freq Hz	Pos Dev (kHz)	Neg Dev (kHz)
100	0.34	0.35
200	1.23	1.09
300	1.97	1.78
400	1.97	1.81
500	2.04	1.97
800	2.16	2.06
1000	2.17	2.13
1500	2.14	2.07
2000	2.06	2.03
2500	1.75	1.71
3000	1.15	1.14
4000	0.36	0.35
5000	0.16	0.13

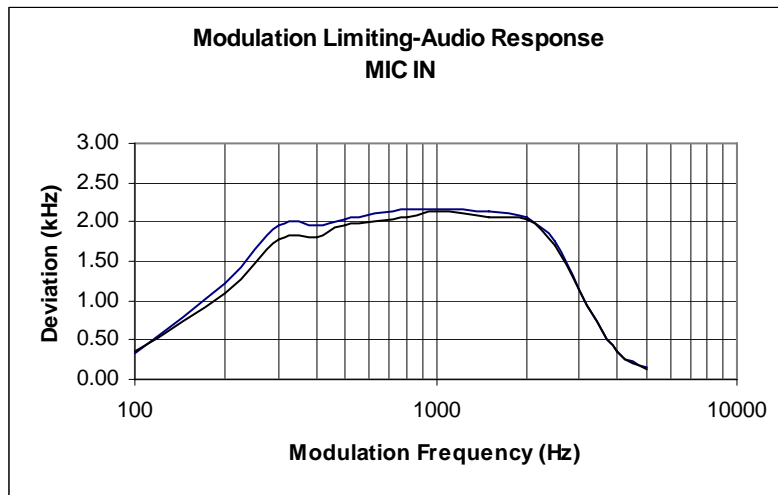

DEVIATION LIMITING WITH INPUT VOLTAGE  
20 dB ABOVE 60% RATED DEVIATION AT 3000 Hz

For 11K0F3E

**MIC IN**

Mod. Freq Hz	Pos Dev (kHz)	Neg Dev (kHz)
100	1.25	1.37
200	1.92	1.79
300	2.12	2.08
400	2.20	2.12
500	2.22	2.13
800	2.20	2.16
1000	2.13	2.16
1500	2.13	2.06
2000	2.04	2.05
2500	1.75	1.73
3000	1.15	1.14
4000	0.37	0.35
5000	0.16	0.14

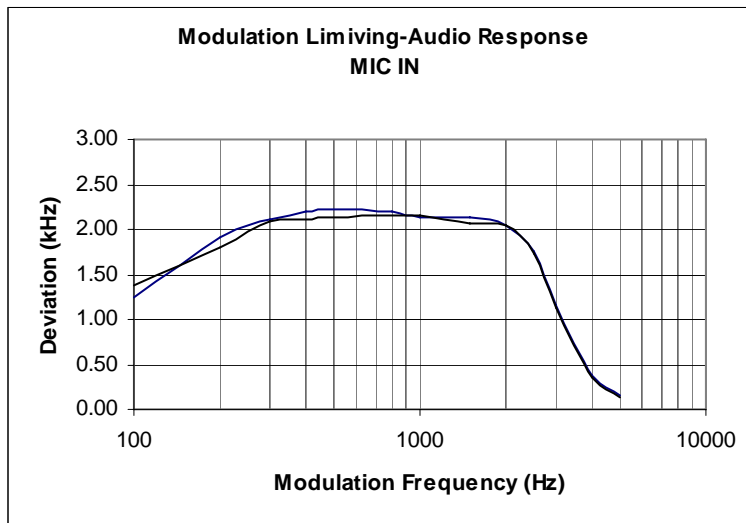

DEVIATION LIMITING WITH INPUT VOLTAGE  
20 dB ABOVE 60% RATED DEVIATION AT 300 Hz

For 11K0F3E

**AUX w/o Pre-emphasis**

Mod. Freq Hz	Pos Dev (kHz)	Neg Dev (kHz)
100	2.01	2.03
200	2.05	2.02
300	2.12	2.23
400	2.11	2.20
500	2.10	2.19
800	2.10	2.23
1000	2.03	2.22
1500	2.04	2.16
2000	2.02	2.06
2500	1.75	1.75
3000	1.14	1.14
4000	0.38	0.35
5000	0.16	0.14

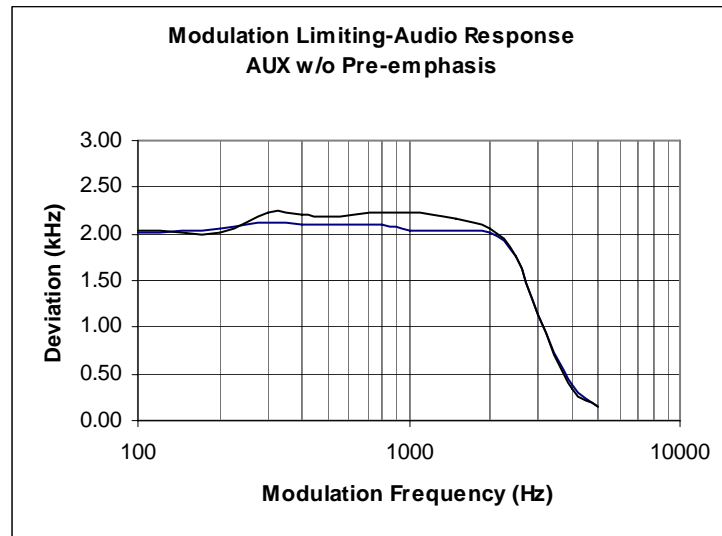

DEVIATION LIMITING WITH INPUT VOLTAGE  
20 dB ABOVE 60% RATED DEVIATION AT 1000 Hz

For 11K0F3E

**AUX w/o Pre-emphasis**

Mod. Freq Hz	Pos Dev (kHz)	Neg Dev (kHz)
100	2.00	1.88
200	2.01	2.10
300	2.07	2.17
400	2.04	2.19
500	2.04	2.24
800	2.07	2.16
1000	2.09	2.19
1500	2.07	2.13
2000	2.04	1.98
2500	1.66	1.74
3000	1.10	1.13
4000	0.37	0.35
5000	0.09	0.14

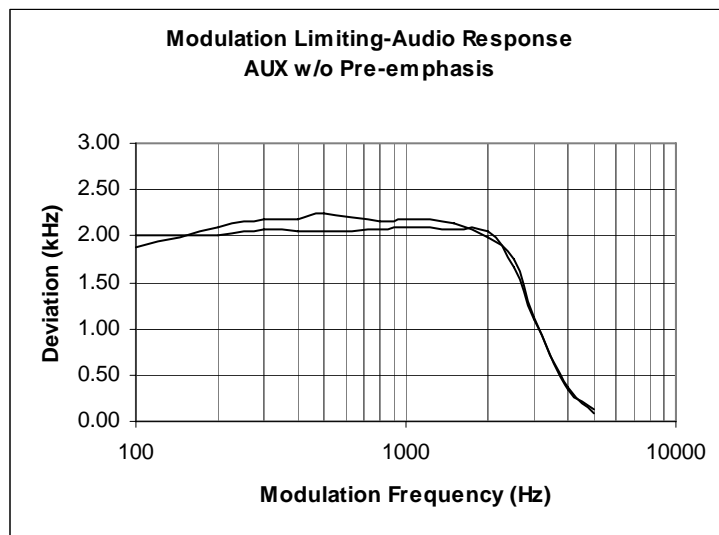

DEVIATION LIMITING WITH INPUT VOLTAGE  
20 dB ABOVE 60% RATED DEVIATION AT 3000 Hz

For 11K0F3E

**AUX w/o Pre-emphasis**

Mod. Freq Hz	Pos Dev (kHz)	Neg Dev (kHz)
100	1.98	2.02
200	1.95	2.08
300	2.05	2.14
400	2.13	2.15
500	2.10	2.13
800	2.06	2.20
1000	2.06	2.19
1500	2.06	2.13
2000	2.04	2.04
2500	1.73	1.74
3000	1.14	1.12
4000	0.37	0.33
5000	0.16	0.14

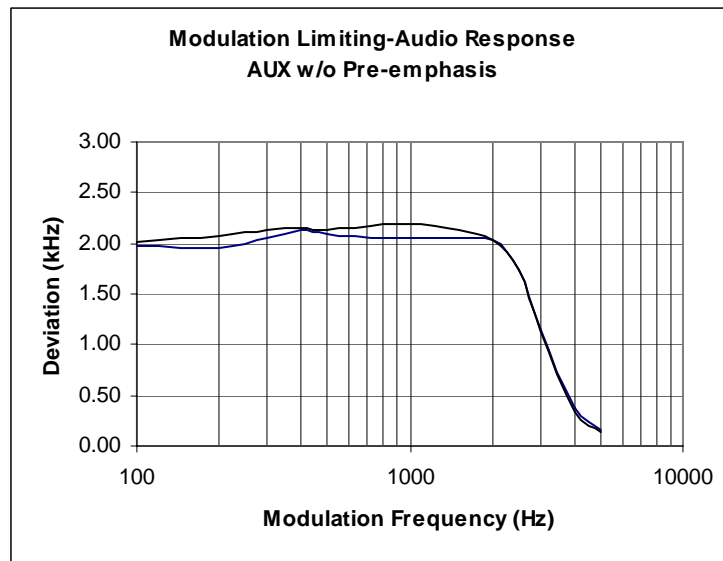



DEVIATION LIMITING WITH INPUT VOLTAGE  
20 dB ABOVE 60% RATED DEVIATION AT 300 Hz

For 11K0F3E

**AUX with Pre-emphasis**

Mod. Freq Hz	Pos Dev (kHz)	Neg Dev (kHz)
100	1.81	1.76
200	1.81	1.86
300	1.88	1.97
400	1.94	2.05
500	1.85	2.16
800	1.96	2.11
1000	1.98	2.07
1500	2.13	2.00
2000	2.06	1.98
2500	1.70	1.70
3000	1.13	1.13
4000	0.37	0.36
5000	0.14	0.11

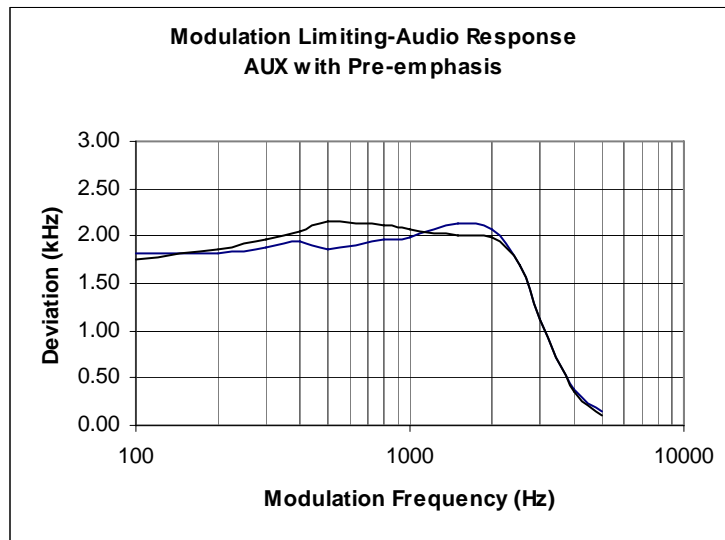

DEVIATION LIMITING WITH INPUT VOLTAGE  
20 dB ABOVE 60% RATED DEVIATION AT 1000 Hz

For 11K0F3E

**AUX with Pre-emphasis**

Mod. Freq Hz	Pos Dev (kHz)	Neg Dev (kHz)
100	1.93	1.67
200	1.83	1.81
300	1.95	1.90
400	1.87	1.90
500	1.90	2.03
800	1.93	2.10
1000	1.97	2.07
1500	2.09	2.02
2000	2.05	1.97
2500	1.70	1.70
3000	1.13	1.13
4000	0.36	0.38
5000	0.15	0.14

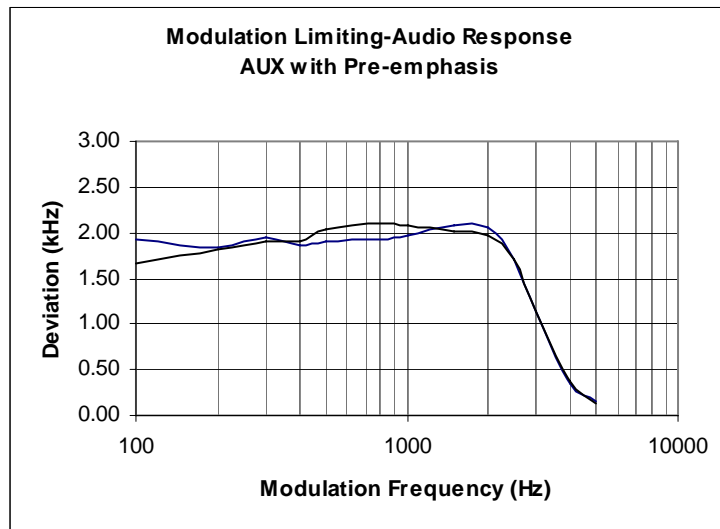

DEVIATION LIMITING WITH INPUT VOLTAGE  
 20 dB ABOVE 60% RATED DEVIATION AT 3000 Hz

For 11K0F3E

**AUX with Pre-emphasis**

Mod. Freq	Pos Dev	Neg Dev
Hz	(kHz)	(kHz)
100	1.90	1.75
200	2.00	1.86
300	1.82	2.04
400	1.95	2.06
500	1.95	2.17
800	1.99	2.11
1000	2.02	2.12
1500	2.12	2.07
2000	2.06	2.03
2500	1.74	1.66
3000	1.13	1.13
4000	0.36	0.36
5000	0.16	0.13

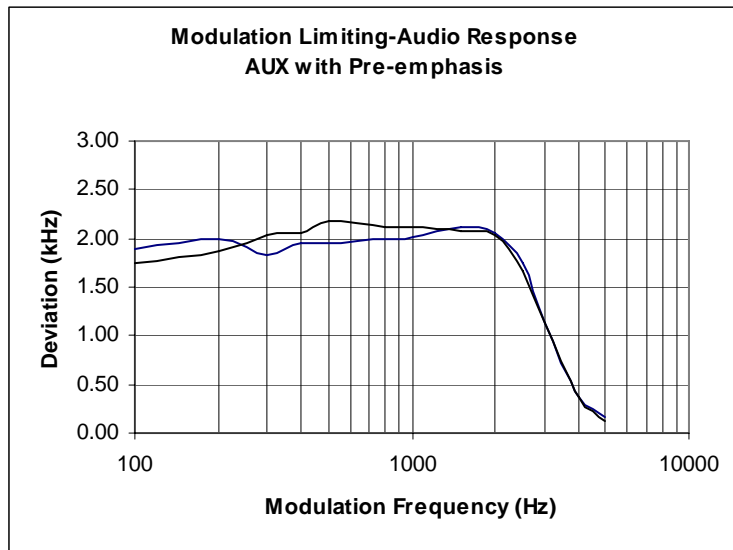

Modulation Versus Input Voltage for  
11KOF3E  
MIC IN

Input Voltage (Vrms)	FM=300 Hz		FM=1000 Hz		FM=3000 Hz	
	Pos Dev	Neg Dev	Pos Dev	Neg Dev	Pos Dev	Neg Dev
0.000	0.11	0.09	0.11	0.10	0.13	0.12
0.003	0.11	0.16	0.24	0.25	0.65	0.51
0.005	0.16	0.14	0.36	0.33	0.51	0.49
0.010	0.19	0.23	0.59	0.62	0.86	0.84
0.020	0.31	0.28	1.11	1.11	1.23	1.20
0.030	0.37	0.40	1.63	1.64	1.25	1.23
0.040	0.49	0.47	2.05	1.93	1.26	1.26
0.050	0.57	0.58	2.14	2.03	1.24	1.27
0.060	0.70	0.66	2.20	2.06	1.27	1.26
0.070	0.76	0.78	2.23	2.16	1.27	1.25
0.080	0.88	0.87	2.26	2.15	1.27	1.26
0.090	0.96	0.98	2.25	2.18	1.26	1.27
0.100	1.06	1.05	2.28	2.20	1.27	1.25
0.120	1.26	1.31	2.27	2.22	1.24	1.28
0.150	1.56	1.54	2.30	2.21	1.27	1.25
0.180	1.86	1.84	2.28	2.27	1.25	1.26
0.200	2.02	1.84	2.30	2.22	1.27	1.27
0.250	1.98	1.89	2.29	2.28	1.26	1.27
0.300	2.01	1.91	2.34	2.27	1.27	1.26
0.350	2.01	1.95	2.33	2.25	1.28	1.25
0.400	2.02	1.94	2.32	2.30	1.28	1.26
0.500	2.02	2.02	2.32	2.28	1.27	1.27
0.700	2.08	2.00	2.33	2.20	1.24	1.25
1.000	2.15	2.18	2.32	2.30	1.27	1.28
2.000	2.25	2.10	2.37	2.27	1.28	1.36
3.000	2.36	1.86	2.18	2.00	1.28	1.29

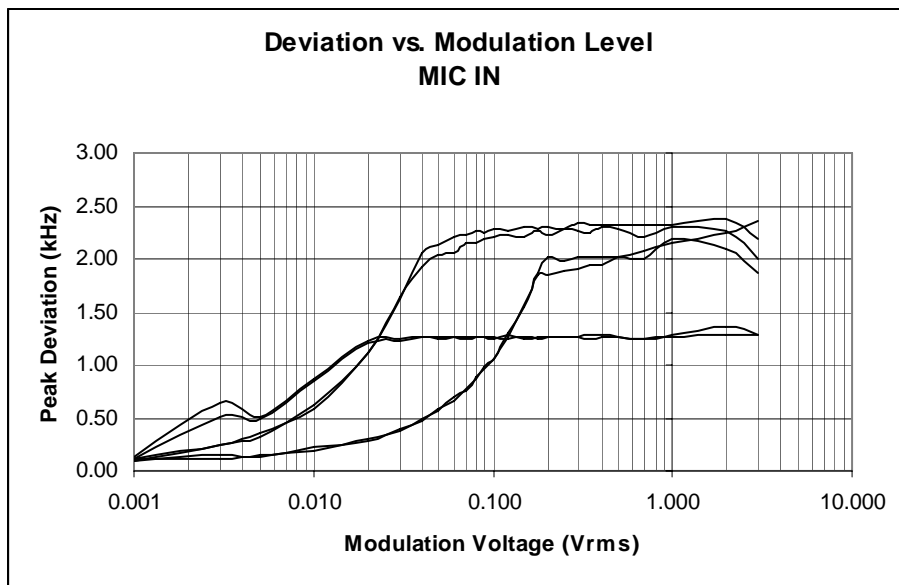

Modulation Versus Input Voltage for  
11K0F3E

**AUX w/o Pre-emphasis**

Input Voltage (Vrms)	FM=300 Hz		FM=1000 Hz		FM=3000 Hz	
	Pos Dev	Neg Dev	Pos Dev	Neg Dev	Pos Dev	Neg Dev
0.000	0.06	0.03	0.07	0.06	0.07	0.05
0.003	0.17	0.15	0.17	0.16	0.11	0.08
0.005	0.22	0.22	0.19	0.22	0.14	0.12
0.010	0.40	0.41	0.40	0.32	0.23	0.23
0.020	0.73	0.73	0.78	0.75	0.41	0.40
0.030	1.05	1.04	1.13	1.12	0.59	0.57
0.040	1.43	1.43	1.48	1.46	0.77	0.74
0.050	1.79	1.66	1.82	1.70	0.93	0.94
0.060	1.97	1.80	1.97	1.77	1.04	0.97
0.070	1.92	1.83	2.02	1.92	1.08	1.06
0.080	1.97	1.77	2.02	1.95	1.08	1.09
0.090	1.87	1.79	2.08	1.98	1.06	1.12
0.100	1.87	1.89	2.07	2.00	1.12	1.10
0.120	2.01	1.87	2.13	2.05	1.07	1.14
0.150	1.85	1.82	2.14	2.06	1.13	1.14
0.180	1.98	1.86	2.15	2.03	1.13	1.13
0.200	1.93	1.98	2.14	2.10	1.15	1.12
0.250	2.00	1.92	2.12	2.06	1.15	1.13
0.300	2.02	2.09	2.13	2.15	1.14	1.05
0.350	2.10	2.06	2.12	2.17	1.16	1.12
0.400	2.03	2.19	2.09	2.19	1.15	1.15
0.500	1.99	2.22	2.04	2.23	1.15	1.11
0.700	2.00	2.24	2.04	2.24	1.15	1.06
1.000	2.15	2.15	2.09	2.20	1.16	1.13
2.000	2.26	2.21	2.10	2.10	1.14	1.12
3.000	2.18	2.08	2.15	2.14	1.17	1.15

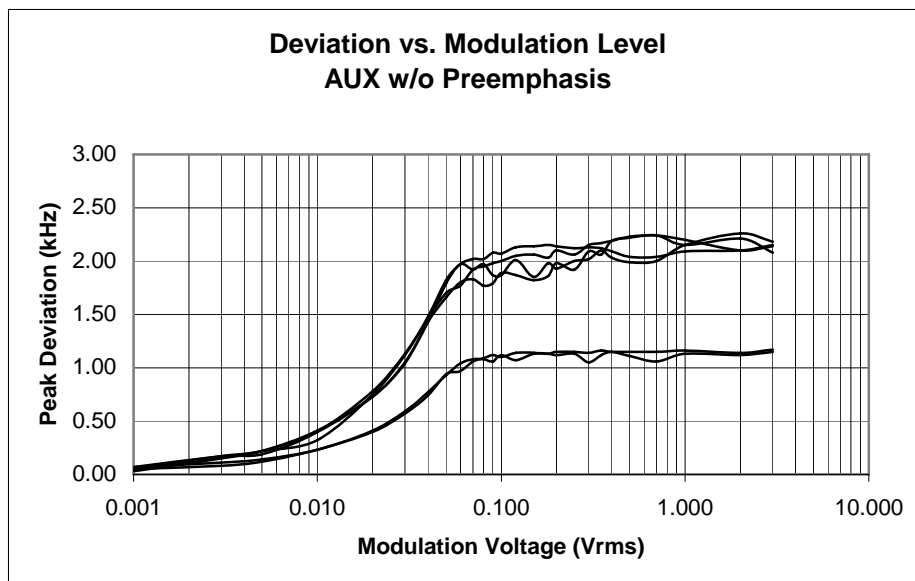

Modulation Versus Input Voltage for  
11K0F3E

**AUX with Pre-emphasis**

Input Voltage (Vrms)	FM=300 Hz		FM=1000 Hz		FM=3000 Hz	
	Pos Dev	Neg Dev	Pos Dev	Neg Dev	Pos Dev	Neg Dev
0.000	0.06	0.04	0.06	0.02	0.06	0.03
0.003	0.06	0.03	0.10	0.06	0.08	0.06
0.005	0.07	0.05	0.08	0.04	0.14	0.13
0.010	0.07	0.06	0.11	0.09	0.24	0.20
0.020	0.10	0.09	0.18	0.18	0.38	0.37
0.030	0.12	0.09	0.24	0.22	0.58	0.58
0.040	0.14	0.11	0.28	0.28	0.77	0.69
0.050	0.15	0.14	0.35	0.37	0.93	0.92
0.060	0.16	0.15	0.45	0.43	1.03	0.93
0.070	0.18	0.08	0.48	0.45	1.06	1.06
0.080	0.15	0.20	0.53	0.55	1.02	1.07
0.090	0.23	0.19	0.63	0.63	1.10	1.10
0.100	0.25	0.22	0.71	0.64	1.10	1.09
0.120	0.29	0.27	0.84	0.74	1.12	1.09
0.150	0.28	0.29	1.04	1.03	1.14	1.14
0.180	0.41	0.39	1.23	1.25	1.07	1.14
0.200	0.45	0.44	1.37	1.36	1.14	1.04
0.250	0.57	0.48	1.69	1.67	1.09	1.15
0.300	0.67	0.64	2.10	1.83	1.09	1.12
0.350	0.85	0.79	2.12	1.87	1.14	1.14
0.400	1.06	0.98	2.13	1.85	1.15	1.13
0.500	1.43	1.36	2.14	1.95	1.15	1.13
0.700	2.00	1.67	2.18	2.06	1.16	1.13
1.000	1.85	1.76	2.15	2.02	1.14	1.12
2.000	1.88	1.85	2.08	2.10	1.15	1.14
3.000	1.91	1.91	2.02	2.05	1.15	1.14

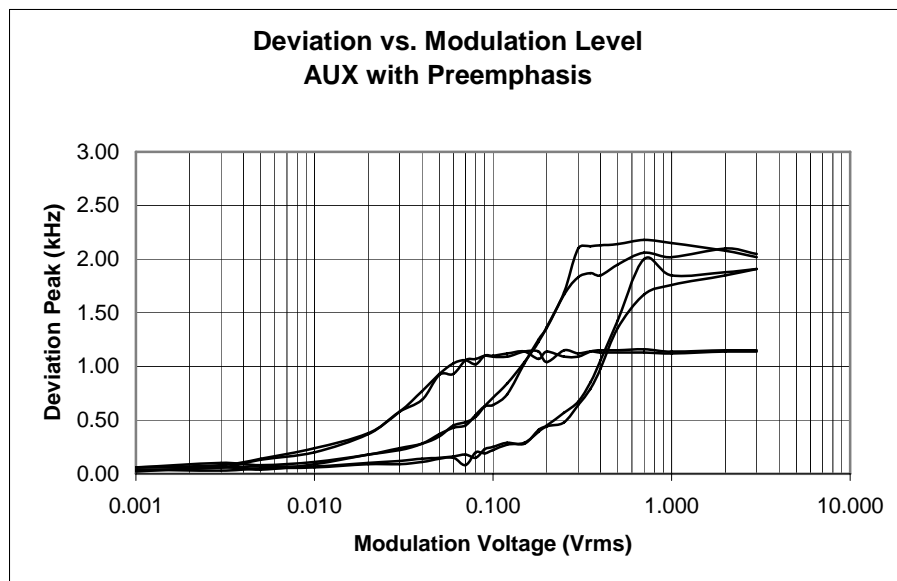

NAME OF TEST: Transmitter Occupied Bandwidth for Emission Designator

RULE PART NUMBER: 2.202, 90.209 (b)(5), 90.210(d), 2.1049 (c) (1)

MINIMUM STANDARDS: **Mask D**  
 Sidebands and Spurious [Rule 90.210 (d), P = 5 Watts and P=0.1 Watt]  
 Authorized Bandwidth = 11.25 kHz [Rule 90.209(b) (5)]  
 From Fo to 5.625 kHz, down 0 dB.  
 Greater than 5.625 kHz to 12.5 kHz, down 7.27( $f_d$ -2.88kHz) dB.  
 Greater than 12.5 kHz, at least 50+10log<sub>10</sub>(P) or 70 dB, which ever is the lesser attenuation

Attenuation = 0 dB at Fo to 5.625 kHz  
 Attenuation = 20 dB at 5.625 kHz and 70 dB at 12.5 kHz  
 Attenuation = 57 dB at greater than 12.5 kHz @ 5 Watts  
 Attenuation = 40 dB at greater than 12.5 kHz @ 0.1 Watt

TEST RESULTS: Meets minimum standards (see data on following page)  
 With 2.5 kHz deviation

TEST CONDITIONS: Standard Test Conditions, 25 C

TEST PROCEDURE: TIA/EIA – 603-B, 2.2.13, 3.2.11.2

TEST EQUIPMENT: 50 Ohm Attenuators, Pasternack Model PE4131 / 10 dB / 20 Watt  
 50 Ohm Attenuators, MCL Model 5W-S20 / 20 dB / 5 Watt  
 50 Ohm Attenuators, Inmet Model 6B-10W / 20 dB / 10 Watt  
 Power Supply, Instek Model GPS-2303  
 Spectrum Analyzer, Agilent Model E4404B  
 Audio Generator, Model HP 8903A  
 Modulation Analyzer, Model HP8901A

TEST SET-UP:

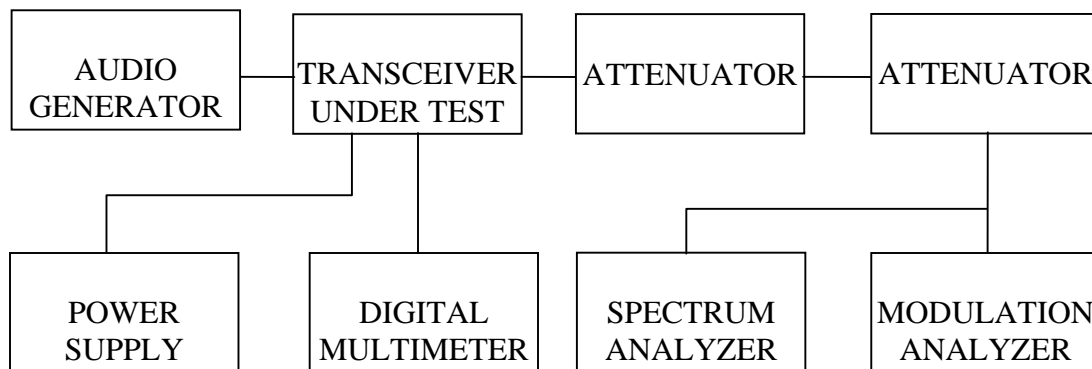

MODULATION SOURCE DESCRIPTION:

HP-8903A was used to provide modulation at 2.5 kHz. The audio signal was applied to the audio input of the DL-3232 loader board. Deviation was set via the loader board

NECESSARY BANDWIDTH CALCULATION

$$B_n = 2M + 2DK$$

M= 3000 Hz. This is the highest modulating frequency widely recognized by the industry as a standard for voice.

D = 2500 Hz. This is the maximum deviation.

$$K = 1$$

$$B_n = 2(3000) + 2(2500)(1) = 11,000 \text{ Hz.}$$

The corresponding emission designator prefix for necessary bandwidth = **11K0**.



Frequency: 150.002500 MHz  
 Power: 5 W

MIC IN

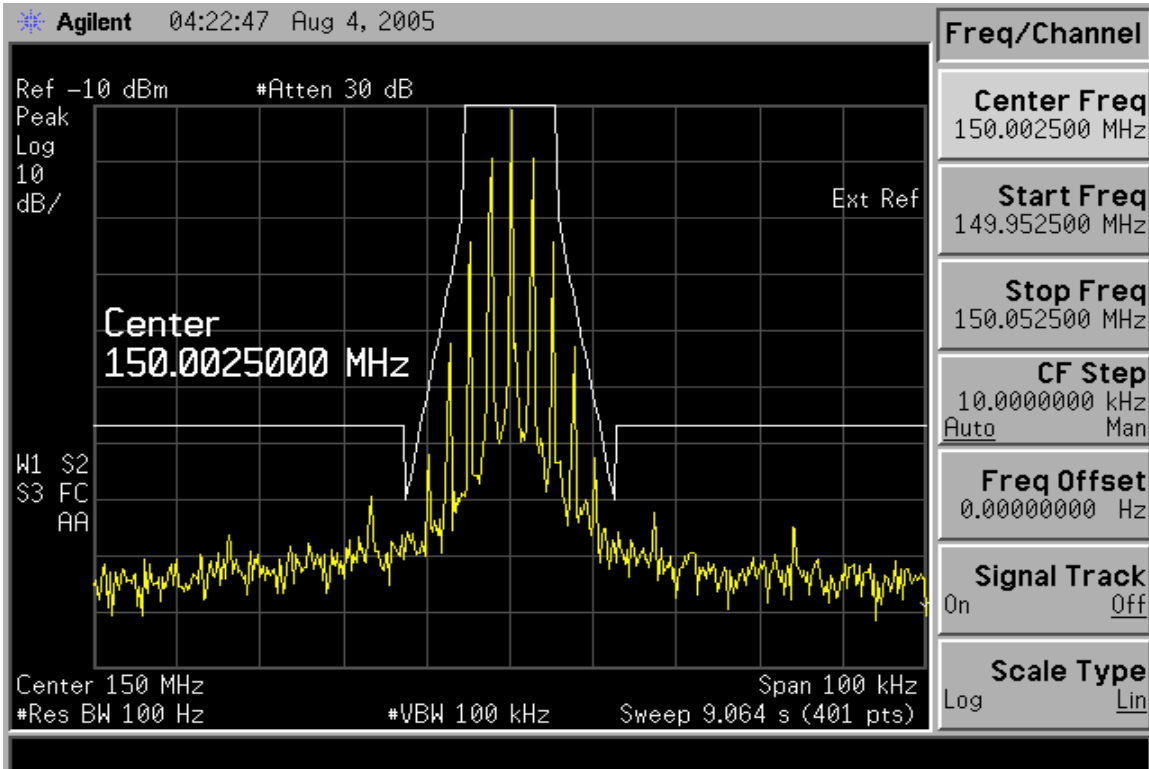

Frequency: 150.002500 MHz  
 Power: 0.1 W

MIC IN

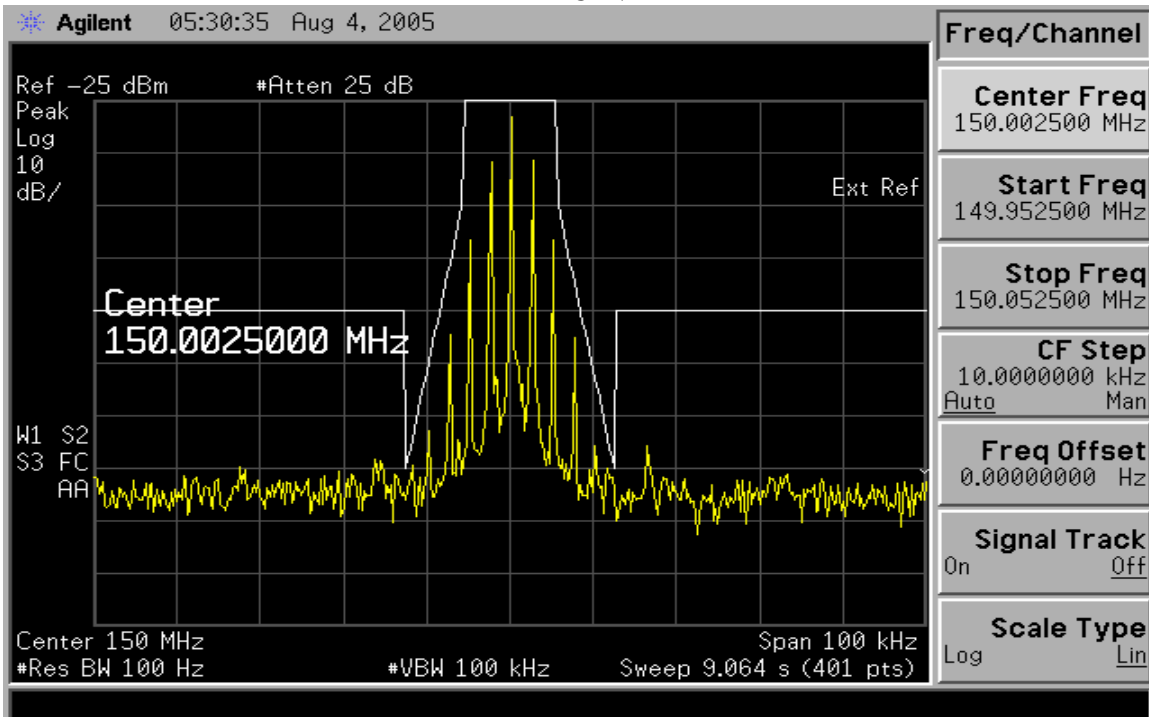

Frequency: 150.002500 MHz  
 Power: 5 W

AUX w/o Pre-emphasis

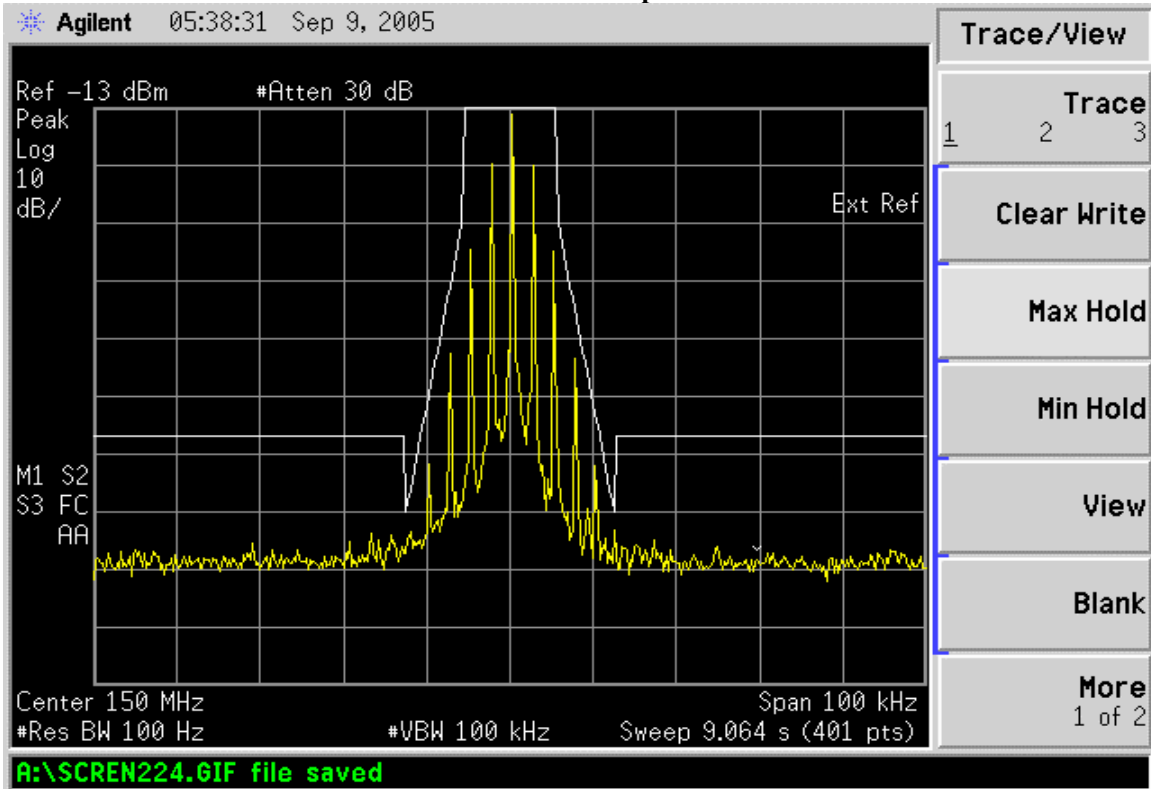

Frequency: 150.002500 MHz  
 Power: 0.1 W

AUX w/o Pre-emphasis

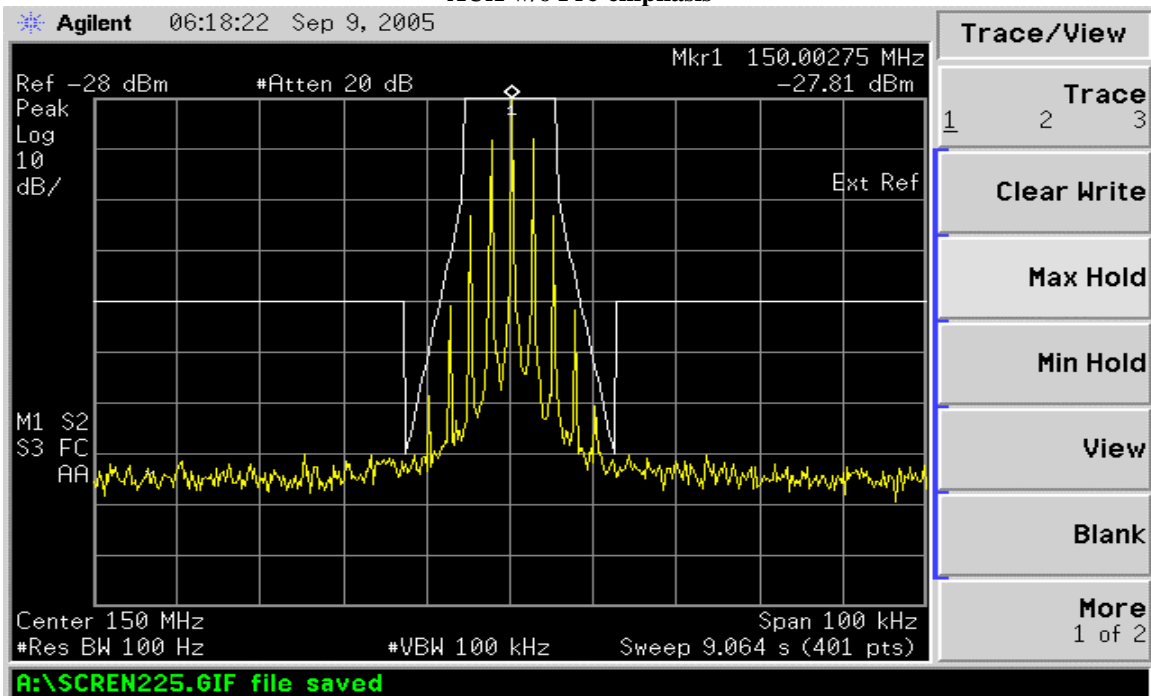

Frequency: 150.002500 MHz  
Power: 5 W

AUX with Pre-emphasis

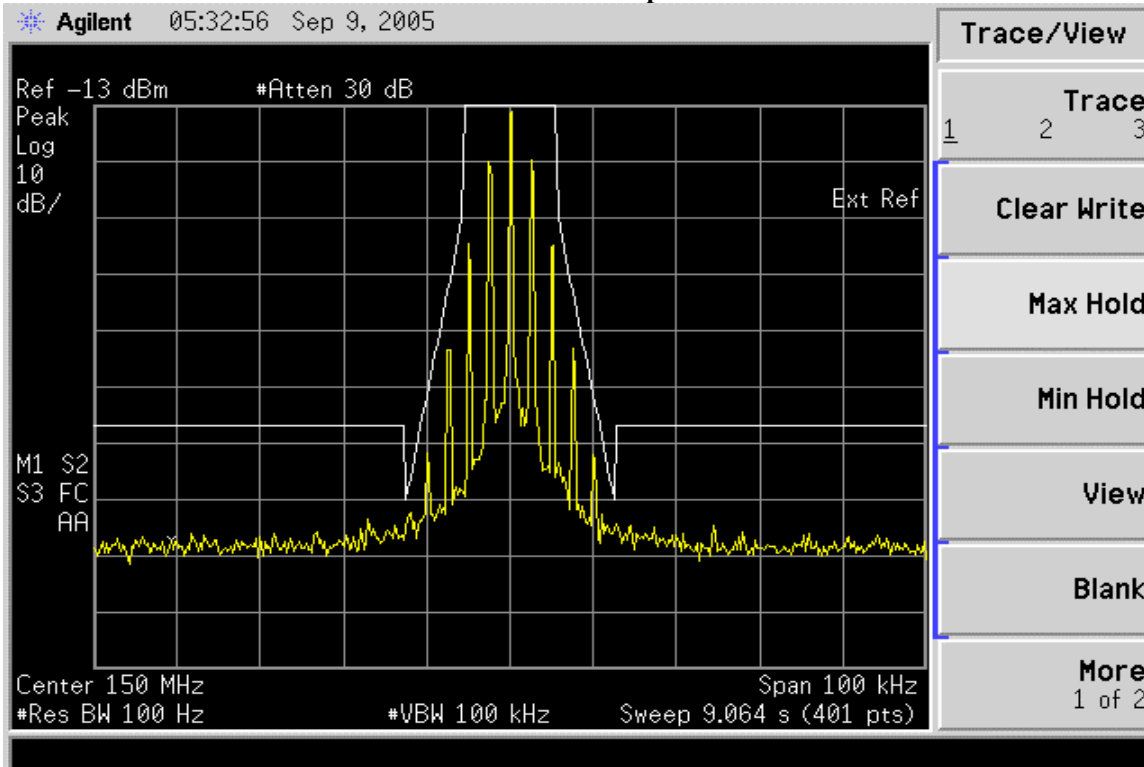

Frequency: 150.002500 MHz  
Power: 0.1 W

AUX with Pre-emphasis

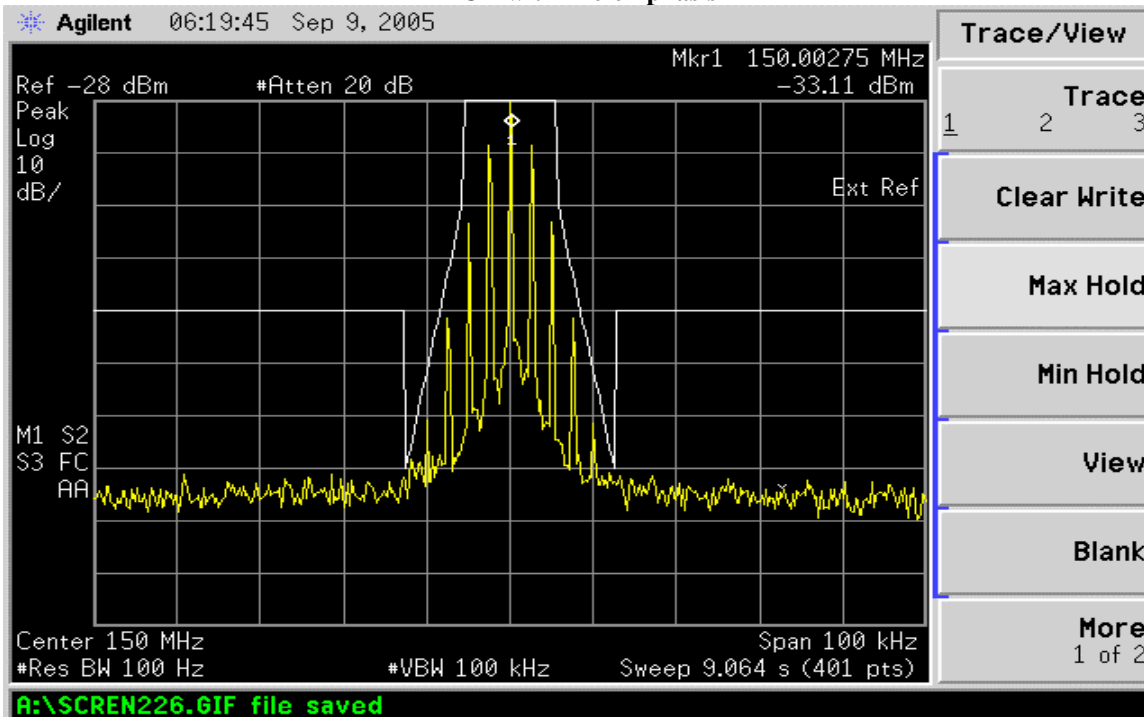

NAME OF TEST: Transmitter Spurious and Harmonic Outputs

RULE PART NUMBER: 2.1051, 90.210 (d)(3)

MINIMUM STANDARDS: For 5 Watts;  $50+10\text{Log}_{10}(5 \text{ Watts}) = -57 \text{ dBc}$   
 For 0.1 Watts;  $50+10\text{Log}_{10}(0.1 \text{ Watts}) = -40 \text{ dBc}$   
 or  $-70 \text{ dBc}$  whichever is the lesser attenuation.

TEST RESULTS: Meets minimum standards ( see data on following page )

TEST CONDITIONS: Standard Test Conditions, 25 C  
 RF Voltage measured at antenna terminals

TEST PROCEDURE: TIA/EIA – 603-B, 2.2.13

TEST EQUIPMENT: 50 Ohm Attenuators, Pasternack Model PE4131 / 10 dB / 20 Watt  
 50 Ohm Attenuators, MCL Model 5W-S20 / 20 dB / 5 Watt  
 50 Ohm Attenuators, Inmet Model 6B-10W / 20 dB / 10 Watt  
 Power Supply, Instek Model GPS-2303  
 Spectrum Analyzer, Advantest Model R3265A  
 Reference Generator, Agilent Model E82570  
 Notch Filter

TEST SET-UP:

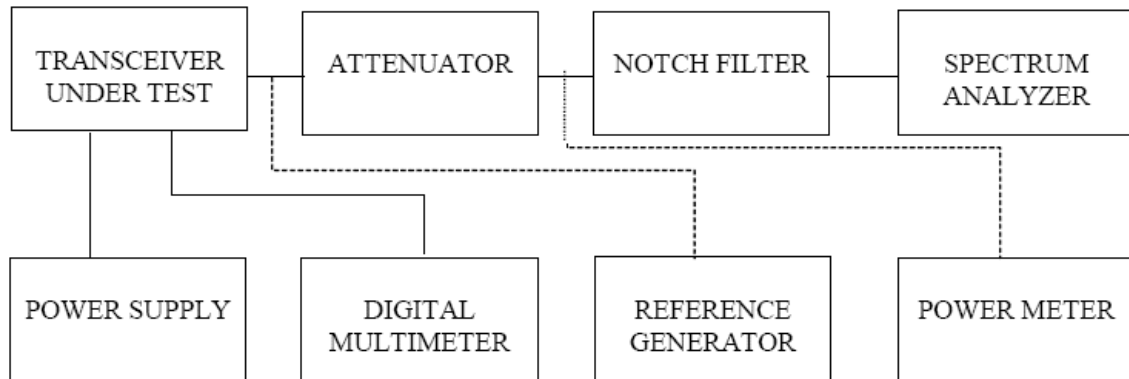

## MEASUREMENT PROCEDURE:

1. The transmitter carrier output frequency is 137.000, 162.000, 150.000, and 174.000. The reference oscillator frequency is 17.5000 MHz. The transmitter has voltage levels at 12.5 Volts and 7.2 Volts.
2. After the carrier reference was established on the spectrum analyzer, the notch filter was adjusted to null the carrier fundamental to extend the range of the spectrum analyzer for harmonic measurements.
3. At each spurious frequency, generation substitution was used to establish the true spurious level.
4. The spectrum was scanned to the 10<sup>th</sup> harmonic

## TEST DATA:

$F_o = 137.000$  MHz

12.5 Volts @ 5 Watts = 37.0 dBm

Spec = -57dBc

Harmonic	Frequency ( MHz )	Level Relative to Carrier( dBc )	Passed by ( dB )
2	274	-62.60	-5.60
3	411	-77.30	-20.30
4	548	-91.80	-34.80
5	685	-90.40	-33.40
6	822	-91.30	-34.30
7	959	-93.60	-36.60
8	1096	-89.70	-32.70
9	1233	-89.50	-32.50
10	1370	-102.80	-45.80

$F_o = 162.000$  MHz

12.5 Volts @ 5 Watts = 37.0 dBm

Spec = -57 dBc

Harmonic	Frequency ( MHz )	Level Relative to Carrier( dBc )	Passed by ( dB )
2	324	-60.67	-3.67
3	486	-76.10	-19.10
4	648	-93.30	-36.30
5	810	-87.60	-30.60
6	972	-94.30	-37.30
7	1134	-90.60	-33.60
8	1296	-87.60	-30.60
9	1458	-93.70	-36.70
10	1620	-97.10	-40.10

$F_o = 150.000 \text{ MHz}$

12.5 Volts @ 5 Watts = 37.0 dBm

Spec = -57dBc

Harmonic	Frequency ( MHz )	Level Relative to Carrier( dBc )	Passed by ( dB )
2	300	-58.46	-1.46
3	450	-72.73	-15.73
4	600	-95.69	-38.69
5	750	-94.41	-37.41
6	900	-103.46	-46.46
7	1050	-100.52	-43.52
8	1200	-100.04	-43.04
9	1350	-100.82	-43.82
10	1500	-103.08	-46.08

$F_o = 174.000 \text{ MHz}$

12.5 Volts @ 5 Watts = 37.0 dBm

Spec = -57dBc

Harmonic	Frequency ( MHz )	Level Relative to Carrier( dBc )	Passed by ( dB )
2	348	-58.00	-1.00
3	522	-71.58	-14.58
4	696	-102.49	-45.49
5	870	-93.73	-36.73
6	1044	-99.92	-42.92
7	1218	-99.21	-42.21
8	1392	-99.33	-42.33
9	1566	-100.34	-43.34
10	1740	-100.76	-43.76

$F_o = 137.000 \text{ MHz}$

7.2 Volts @ 0.1 Watts = 20.0 dBm

Spec = -40dBc

Harmonic	Frequency ( MHz )	Level Relative to Carrier( dBc )	Passed by ( dB )
2	274	-68.40	-28.40
3	411	-98.90	-58.90
4	548	-97.40	-57.40
5	685	-98.30	-58.30
6	822	-95.40	-55.40
7	959	-95.80	-55.80
8	1096	-96.00	-56.00
9	1233	-87.50	-47.50
10	1370	-98.20	-58.20

$F_0 = 162.000 \text{ MHz}$

7.2 Volts @ 0.1 Watts = 20.0 dBm

Spec = -40dBc

Harmonic	Frequency ( MHz )	Level Relative to Carrier( dBc )	Passed by ( dB )
2	324	-69.40	-29.40
3	486	-70.90	-30.90
4	648	-95.70	-55.70
5	810	-95.40	-55.40
6	972	-92.80	-52.80
7	1134	-95.00	-55.00
8	1296	-97.20	-57.20
9	1458	-98.50	-58.50
10	1620	-98.00	-58.00

$F_0 = 150.000 \text{ MHz}$

7.2 Volts @ 0.1 Watts = 20.0 dBm

Spec = -40dBc

Harmonic	Frequency ( MHz )	Level Relative to Carrier( dBc )	Passed by ( dB )
2	300	-68.88	-28.88
3	450	-97.91	-57.91
4	600	-96.78	-56.78
5	750	-97.67	-57.67
6	900	-95.88	-55.88
7	1050	-94.87	-54.87
8	1200	-96.91	-56.91
9	1350	-98.37	-58.37
10	1500	-99.74	-59.74

$F_0 = 174.000 \text{ MHz}$

7.2 Volts @ 0.1 Watts = 20.0 dBm

Spec = -40dBc

Harmonic	Frequency ( MHz )	Level Relative to Carrier( dBc )	Passed by ( dB )
2	348	-69.75	-29.75
3	522	-97.58	-57.58
4	696	-95.09	-55.09
5	870	-95.07	-55.07
6	1044	-93.13	-53.13
7	1218	-94.38	-54.38
8	1392	-96.03	-56.03
9	1566	-68.79	-28.79
10	1740	-67.34	-27.34

NAME OF TEST: Frequency Stability with Variation in Ambient Temperature

RULE PART NUMBER: 2.1055 (a) (b), 90.213 (a)

MINIMUM STANDARD: Shall not exceed  $\pm 0.000250$  % form test frequency, or 2.50 ppm

TEST RESULTS: Meets minimum standard, see data on following page

TEST CONDITIONS: Standard Test Conditions

TEST EQUIPMENT: 50 Ohm Attenuator, Tenuline Model 8340 / 20dB / 25 Watt  
 50 Ohm Attenuator, Tenuline Model 8340 / 10 dB / 25 Watt  
 Frequency Counter, Fluke Model 1920A  
 Power Supply, Model HP-6284A  
 Digital Voltmeter, Fluke 8840A  
 Climate Chamber, Tenney Jr. Model R-404

TEST SET-UP:

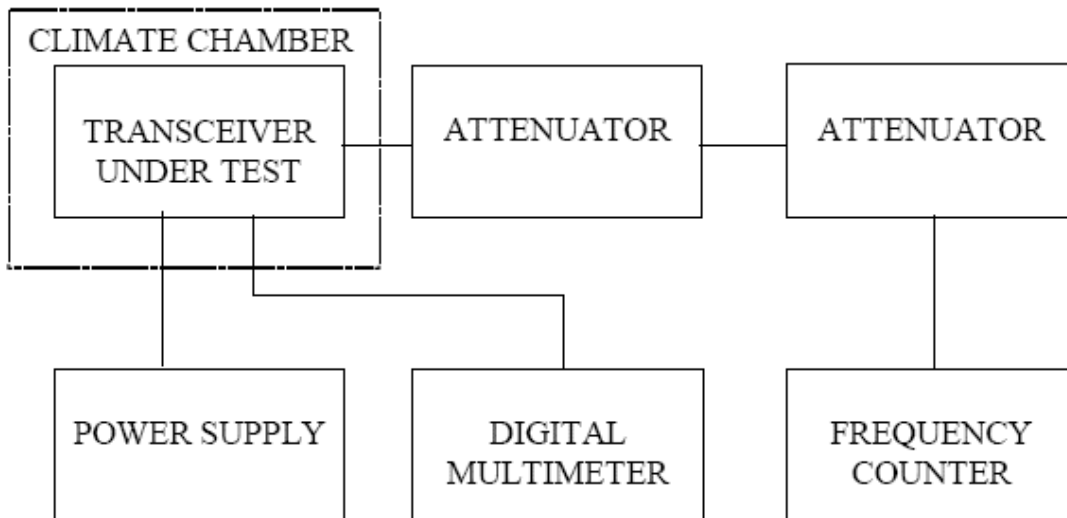



Channel Frequency: 150.00250 MHz  
 Voltage & Power Level: 12.5 Volts @ 5.0 Watts  
 Highest Variation: 1.00

Temperature ( Deg C )	Measured Frequency ( MHz )	Frequency Error ( Hz )	Frequency Error ( ppm )
-30	150.00265	150	1.00
-20	150.00264	140	0.93
-10	150.00261	110	0.73
0	150.00259	90	0.60
10	150.00257	70	0.47
20	150.00246	-40	-0.27
30	150.00251	10	0.07
40	150.00252	10	0.07
50	150.00248	-20	-0.13
60	150.00244	-60	-0.40

Channel Frequency: 150.0025 MHz  
 Voltage & Power Level: 7.2 Volts @ 0.1 Watts  
 Highest Variation: 1.00

Temperature ( Deg C )	Measured Frequency ( MHz )	Frequency Error ( Hz )	Frequency Error ( ppm )
-30	150.002650	150	1.00
-20	150.002650	150	1.00
-10	150.002610	110	0.73
0	150.002580	80	0.53
10	150.005280	80	0.53
20	150.002500	0	0.00
30	150.002500	0	0.00
40	150.002490	-10	-0.07
50	150.002470	-30	-0.20
60	150.002430	-70	-0.47

NAME OF TEST: Field Strength of Spurious Radiation

RULE PART NUMBER: 2.1053, 90.210 (d)(3)

MINIMUM STANDARDS: For 5 Watts;  $50+10\text{Log}_{10}(5 \text{ Watts}) = -57 \text{ dBc}$   
 For 0.1 Watts;  $50+10\text{Log}_{10}(0.1 \text{ Watts}) = -40 \text{ dBc}$   
 or  $-70 \text{ dBc}$  whichever is the lesser attenuation.

TEST RESULTS: Meets minimum standards ( see data on following page )

TEST CONDITIONS: Standard Test Conditions, 25 C

TEST PROCEDURE: TIA/EIA – 603-B, 2.2.12

TEST EQUIPMENT: Waveguide Horn Antenna, EMCO Model 3115  
 Bilog Antenna, Chase Model CBL6111B  
 Log Periodic Linear Polarization Antenna, AILTECH Model 94612-1  
 Dipole Antenna, Electro-Metrics Model EM-6924  
 Power Supply, Model HP-6284A  
 Spectrum Analyzer, Model Hp-8561B  
 Reference Generator, Agilent Model E82570  
 Power Meter, Model HP436A  
 50-Ohm Load, Lucas Weinschel 58-30-43

MEASUREMENT PROCEDURE: Radiated spurious attenuation was measured according to TIA/EIA Standard 603-B Section 2.2.12

TEST SET-UP:

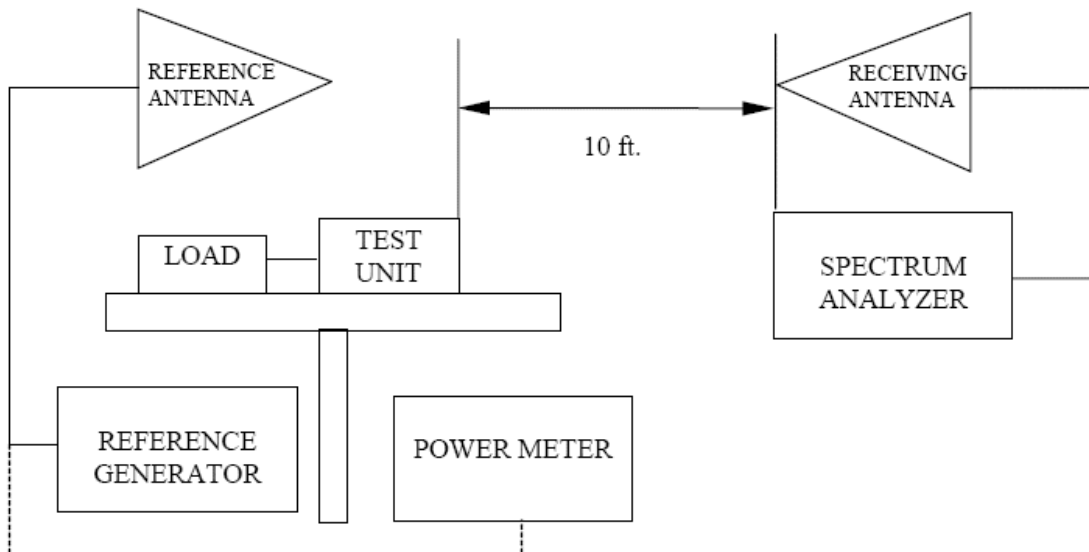

Frequency: 137 MHz  
Power: 5 Watts @ 12.5 Volts

Spurious Frequency (MHz)	Polarization (Horz/Vert)	Spurious Level (dBm)	Substitution Generator (dBm)	Cable Loss (dB)	Antenna Gain (dBd)	Spurious Attenuation dBc
274	H	-88.17	-51.0	1.17	-0.47	-89.6
	V	-80.17	-58.7	1.17	-0.47	-97.3
411	H	-89.67	-63.7	1.50	-0.47	-102.6
	V	-93.83	-63.8	1.50	-0.47	-102.8
548	H	-90.33	-55.3	2.00	-0.47	-94.8
	V	-92.67	-60.7	2.00	-0.47	-100.1
685	H	-94.00	-63.2	2.17	-0.47	-102.8
	V	-95.00	-58.8	2.17	-0.47	-98.5
822	H	-95.33	-55.5	2.50	-0.47	-95.5
	V	-96.73	-59.4	2.50	-0.47	-99.4
959	H	-95.33	-58.5	2.50	-0.47	-98.5
	V	-96.50	-55.3	2.50	-0.47	-95.3
1096	H	-96.17	-62.7	3.17	3.40	-99.4
	V	-97.00	-62.7	3.17	3.40	-99.4
1233	H	-97.00	-57.8	3.33	4.50	-93.7
	V	-97.00	-57.8	3.33	4.50	-93.7
1370	H	-97.00	-60.8	3.50	4.35	-97.0
	V	-97.00	-61.0	3.50	4.35	-97.2

Frequency: 162 MHz  
Power: 5 Watts @ 12.5 Volts

Spurious Frequency (MHz)	Polarization (Horz/Vert)	Spurious Level (dBm)	Substitution Generator (dBm)	Cable Loss (dB)	Antenna Gain (dBd)	Spurious Attenuation dBc
324	H	-97.00	-70.8	1.33	-0.47	-109.6
	V	-96.50	-70.7	1.33	-0.47	-109.5
486	H	-97.00	-70.8	1.83	-0.47	-110.1
	V	-96.83	-66.0	1.83	-0.47	-105.3
648	H	-97.00	-64.8	2.17	-0.47	-104.5
	V	-97.00	-64.3	2.17	-0.47	-104.0
810	H	-96.67	-58.8	2.67	-0.47	-99.0
	V	-95.17	-57.2	2.67	-0.47	-97.3
972	H	-97.00	-60.5	2.50	-0.47	-100.5
	V	-97.00	-53.2	2.50	-0.47	-93.1
1134	H	-94.17	-58.7	3.17	3.60	-95.2
	V	-97.00	-62.7	3.17	3.60	-99.2
1296	H	-96.00	-60.3	3.33	4.60	-96.1
	V	-97.00	-59.7	3.33	4.60	-95.4
1458	H	-96.50	-59.0	3.67	4.20	-95.5
	V	-97.00	-60.3	3.67	4.20	-96.8
1620	H	-97.00	-59.7	3.67	3.65	-96.7
	V	-97.00	-60.2	3.67	3.65	-97.2

Frequency: 150 MHz  
 Power: 5 Watts @ 12.5 Volts

Spurious Frequency (MHz)	Polarization (Horz/Vert)	Spurious Level (dBm)	Substitution Generator (dBm)	Cable Loss (dB)	Antenna Gain (dBd)	Spurious Attenuation dBc
300	H	-87.00	-59.0	1.50	-0.47	-98.0
	V	-91.50	-67.0	1.50	-0.47	-106.0
450	H	-95.33	-69.5	1.83	-0.47	-108.8
	V	-97.00	-64.8	1.83	-0.47	-104.1
600	H	-95.67	-53.8	2.00	-0.47	-93.3
	V	-97.00	-64.8	2.00	-0.47	-104.3
750	H	-94.83	-62.3	2.50	-0.47	-102.3
	V	-94.33	-54.2	2.50	-0.47	-94.1
900	H	-97.00	-52.2	2.67	-0.47	-92.3
	V	-96.00	-58.0	2.67	-0.47	-98.1
1050	H	-97.00	-64.0	2.83	2.56	-101.3
	V	-96.50	-62.2	2.83	2.56	-99.4
1200	H	-96.50	-58.2	2.83	4.30	-93.7
	V	-97.00	-60.2	2.83	4.30	-95.7
1350	H	-97.00	-61.7	3.33	4.45	-97.6
	V	-97.00	-61.3	3.33	4.45	-97.2
1500	H	-97.00	-59.8	3.33	4.03	-96.1
	V	-97.00	-58.7	3.33	4.03	-95.0

Frequency: 174 MHz  
 Power: 5 Watts @ 12.5 Volts

Spurious Frequency (MHz)	Polarization (Horz/Vert)	Spurious Level (dBm)	Substitution Generator (dBm)	Cable Loss (dB)	Antenna Gain (dBd)	Spurious Attenuation dBc
348	H	-95.60	-70.8	1.50	-0.47	-109.7
	V	-92.67	-65.7	1.50	-0.47	-104.6
522	H	-94.33	-65.0	1.83	-0.47	-104.3
	V	-95.00	-63.7	1.83	-0.47	-103.0
696	H	-95.83	-64.8	2.17	-0.47	-104.5
	V	-96.17	-58.5	2.17	-0.47	-98.1
870	H	-96.50	-47.2	2.17	-0.47	-86.8
	V	-97.00	-61.7	2.17	-0.47	-101.3
1044	H	-95.67	-62.5	2.83	2.56	-99.8
	V	-97.00	-62.2	2.83	2.56	-99.4
1218	H	-97.00	-58.0	3.00	4.40	-93.6
	V	-97.00	-58.1	3.00	4.40	-93.7
1392	H	-97.00	-59.7	3.50	4.30	-95.9
	V	-97.00	-60.5	3.50	4.30	-96.7
1566	H	-97.00	-59.7	3.50	3.85	-96.3
	V	-97.00	-58.5	3.50	3.85	-95.2
1740	H	-97.00	-57.8	3.50	3.15	-95.2
	V	-97.00	-57.7	3.50	3.15	-95.0

Frequency: 137 MHz  
Power: 0.1 Watts @ 7.2 Volts

Spurious Frequency (MHz)	Polarization (Horz/Vert)	Spurious Level (dBm)	Substitution Generator (dBm)	Cable Loss (dB)	Antenna Gain (dBd)	Spurious Attenuation dBc
274	H	-96.17	-59.0	1.17	-0.47	-80.6
	V	-95.83	-74.3	1.17	-0.47	-96.0
411	H	-96.17	-70.2	1.50	-0.47	-92.1
	V	-95.50	-65.5	1.50	-0.47	-87.5
548	H	-97.00	-62.0	2.00	-0.47	-84.5
	V	-97.00	-65.0	2.00	-0.47	-87.5
685	H	-96.83	-66.0	2.17	-0.47	-88.6
	V	-97.00	-60.8	2.17	-0.47	-83.5
822	H	-96.83	-57.0	2.50	-0.47	-80.0
	V	-96.17	-58.8	2.50	-0.47	-81.8
959	H	-96.50	-59.7	2.50	-0.47	-82.6
	V	-97.00	-55.8	2.50	-0.47	-78.8
1096	H	-95.67	-62.2	3.17	3.40	-81.9
	V	-97.00	-62.7	3.17	3.40	-82.4
1233	H	-96.33	-57.2	3.33	4.50	-76.0
	V	-97.00	-57.8	3.33	4.50	-76.7
1370	H	-97.00	-60.8	3.50	4.35	-80.0
	V	-97.00	-61.0	3.50	4.35	-80.2

Frequency: 162 MHz  
Power: 0.1 Watts @ 7.2 Volts

Spurious Frequency (MHz)	Polarization (Horz/Vert)	Spurious Level (dBm)	Substitution Generator (dBm)	Cable Loss (dB)	Antenna Gain (dBd)	Spurious Attenuation dBc
324	H	-95.3	-69.2	1.33	-0.47	-91.0
	V	-96.2	-70.3	1.33	-0.47	-92.1
486	H	-97.0	-70.8	1.83	-0.47	-93.1
	V	-97.0	-66.2	1.83	-0.47	-88.5
648	H	-97.0	-64.8	2.17	-0.47	-87.5
	V	-97.0	-64.3	2.17	-0.47	-87.0
810	H	-97.0	-59.2	2.67	-0.47	-82.3
	V	-97.0	-59.0	2.67	-0.47	-82.1
972	H	-97.0	-60.5	2.50	-0.47	-83.5
	V	-97.0	-53.2	2.50	-0.47	-76.1
1134	H	-96.7	-61.2	3.17	3.60	-80.7
	V	-95.5	-61.2	3.17	3.60	-80.7
1296	H	-97.0	-61.3	3.33	4.60	-80.1
	V	-96.9	-59.6	3.33	4.60	-78.3
1458	H	-97.0	-59.5	3.67	4.20	-79.0
	V	-97.0	-60.3	3.67	4.20	-79.8
1620	H	-97.0	-59.7	3.67	3.65	-79.7
	V	-97.0	-60.2	3.67	3.65	-80.2

Frequency: 150 MHz  
 Power: 0.1 Watts @ 7.2 Volts

Spurious Frequency (MHz)	Polarization (Horz/Vert)	Spurious Level (dBm)	Substitution Generator (dBm)	Cable Loss (dB)	Antenna Gain (dBd)	Spurious Attenuation dBc
300	H	-97.0	-69.0	1.50	-0.47	-91.0
	V	-97.0	-72.5	1.50	-0.47	-94.5
450	H	-97.0	-71.2	1.83	-0.47	-93.5
	V	-97.0	-64.8	1.83	-0.47	-87.1
600	H	-97.0	-55.2	2.00	-0.47	-77.6
	V	-97.0	-64.8	2.00	-0.47	-87.3
750	H	-97.0	-64.5	2.50	-0.47	-87.5
	V	-97.0	-56.8	2.50	-0.47	-79.8
900	H	-97.0	-52.2	2.67	-0.47	-75.3
	V	-97.0	-59.0	2.67	-0.47	-82.1
1050	H	-97.0	-64.0	2.83	2.56	-84.3
	V	-97.0	-62.7	2.83	2.56	-82.9
1200	H	-97.0	-58.7	2.83	4.30	-77.2
	V	-97.0	-60.2	2.83	4.30	-78.7
1350	H	-97.0	-61.7	3.33	4.45	-80.6
	V	-97.0	-61.3	3.33	4.45	-80.2
1500	H	-97.0	-59.8	3.33	4.03	-79.1
	V	-97.0	-58.7	3.33	4.03	-78.0

Frequency: 174 MHz  
 Power: 0.1 Watts @ 7.2 Volts

Spurious Frequency (MHz)	Polarization (Horz/Vert)	Spurious Level (dBm)	Substitution Generator (dBm)	Cable Loss (dB)	Antenna Gain (dBd)	Spurious Attenuation dBc
348	H	-97.0	-72.2	1.50	-0.47	-94.1
	V	-97.0	-70.0	1.50	-0.47	-92.0
522	H	-97.0	-67.7	1.83	-0.47	-90.0
	V	-97.0	-65.7	1.83	-0.47	-88.0
696	H	-97.0	-66.0	2.17	-0.47	-88.6
	V	-97.0	-59.3	2.17	-0.47	-82.0
870	H	-97.0	-47.7	2.17	-0.47	-70.3
	V	-97.0	-61.7	2.17	-0.47	-84.3
1044	H	-97.0	-63.8	2.83	2.56	-84.1
	V	-97.0	-62.2	2.83	2.56	-82.4
1218	H	-97.0	-58.0	3.00	4.40	-76.6
	V	-97.0	-58.1	3.00	4.40	-76.7
1392	H	-97.0	-59.7	3.50	4.30	-78.9
	V	-97.0	-60.5	3.50	4.30	-79.7
1566	H	-97.0	-59.7	3.50	3.85	-79.3
	V	-97.0	-58.5	3.50	3.85	-78.2
1740	H	-97.0	-57.8	3.50	3.15	-78.2
	V	-97.0	-57.7	3.50	3.15	-78.0

NAME OF TEST: Frequency Stability with Variation in Supply Voltage

RULE PART NUMBER: 2.1055 (d) (1), 90.213 (a)

MINIMUM STANDARD: Shall not exceed  $\pm 0.000250$  % from the test frequency, 2.50 ppm for  $\pm 15\%$  change in supply voltage.

TEST RESULTS: Meets minimum standard, see data on following page

TEST CONDITIONS: Standard Test Conditions, 25 C

TEST EQUIPMENT: 50 Ohm Attenuator, Tenuline Model 8340 / 20dB / 25 Watt  
 50 Ohm Attenuator, Tenuline Model 8340 / 10dB / 25 Watt  
 Frequency Counter, Fluke Model 1920A  
 Digital Voltmeter, Fluke Model 8012A  
 DC Power Supply, Instek Model GPS-2303

TEST SET-UP:

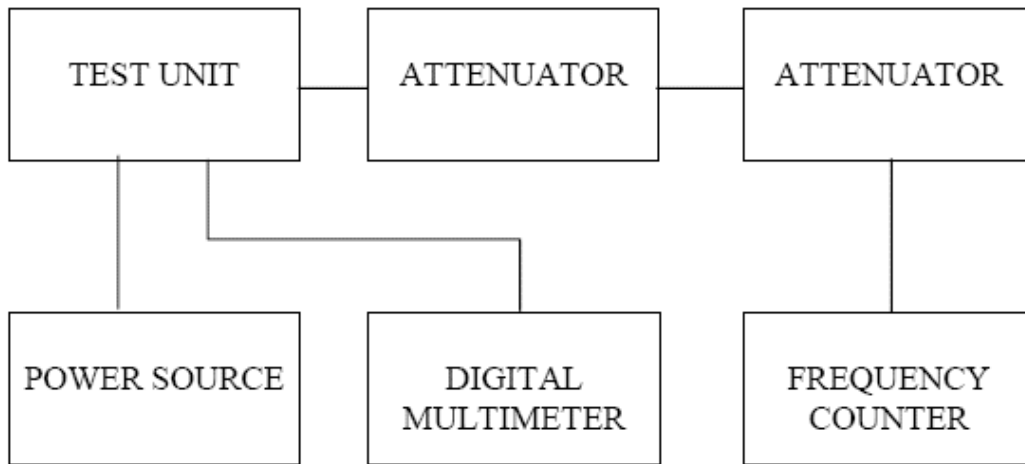

TEST SET-UP

Channel Frequency: 137.000 MHz  
 Tolerance Requirements: 0.00025%  
 Highest Variation: 0.00

Input Voltage ( Vdc )	Frequency ( MHz )	Delta Freq ( % of assigned Freq )	ppm from assigned Frequency
6.0	137.000	0.00	0.00
12.5	137.000	0.00	0.00
15.0	137.000	0.00	0.00

Channel Frequency: 150.000 MHz  
 Tolerance Requirements: 0.00025%  
 Highest Variation: 0.00

Input Voltage ( Vdc )	Frequency ( MHz )	Delta Freq ( % of assigned Freq )	ppm from assigned Frequency
6.0	150.000	0.00	0.00
12.5	150.000	0.00	0.00
15.0	150.000	0.00	0.00



NAME OF TEST: Transient Frequency Behavior

RULE PART NUMBER: 90.214

TEST CONDITIONS: Transient tests were conducted by modulating a 1 kHz tone with 1.5 kHz deviation through the loader audio input.

MINIMUM STANDARD: 12.5 kHz channel (used worst case numbers from 137 to 174 MHz)

<u>TIME INTERVAL</u>	<u>MAXIMUM FREQUENCY DIFFERENCE (kHz)</u>	<u>TIME (ms)</u>
T1	+/- 12.5	5
T2	+/- 6.25	20
T3	+/- 12.5	5

TEST RESULTS: Meets minimum standards, see data on following pages

TEST CONDITIONS: RF Power Level = 5 Watts and 0.1 Watt  
Standard Test Conditions, 25 C

TEST PROCEDURE: TIA/EIA – 603-B, 2.2.19

TEST EQUIPMENT: 50 Ohm Attenuator, Tenuline Model 8340 / 20 dB / 25 Watt  
50 Ohm Attenuator, Tenuline Model 8340 / 10 dB / 25 Watt  
Power Supply, Instek Model GPS-2303  
Digital Voltmeter, Fluke Model 8012A  
Power Combiner, Model MCL ZFSC-4-1  
Modulation Analyzer, Model HP8901A  
Power Meter, Model HP436  
Oscilloscope, Tektronix Model TDS 3014B  
Power Detector, Model JDT lab made  
Directional Coupler, Model HP778D  
Signal Generator, Model HP8657B  
Audio Analyzer, Model HP8903A

TEST SET-UP:

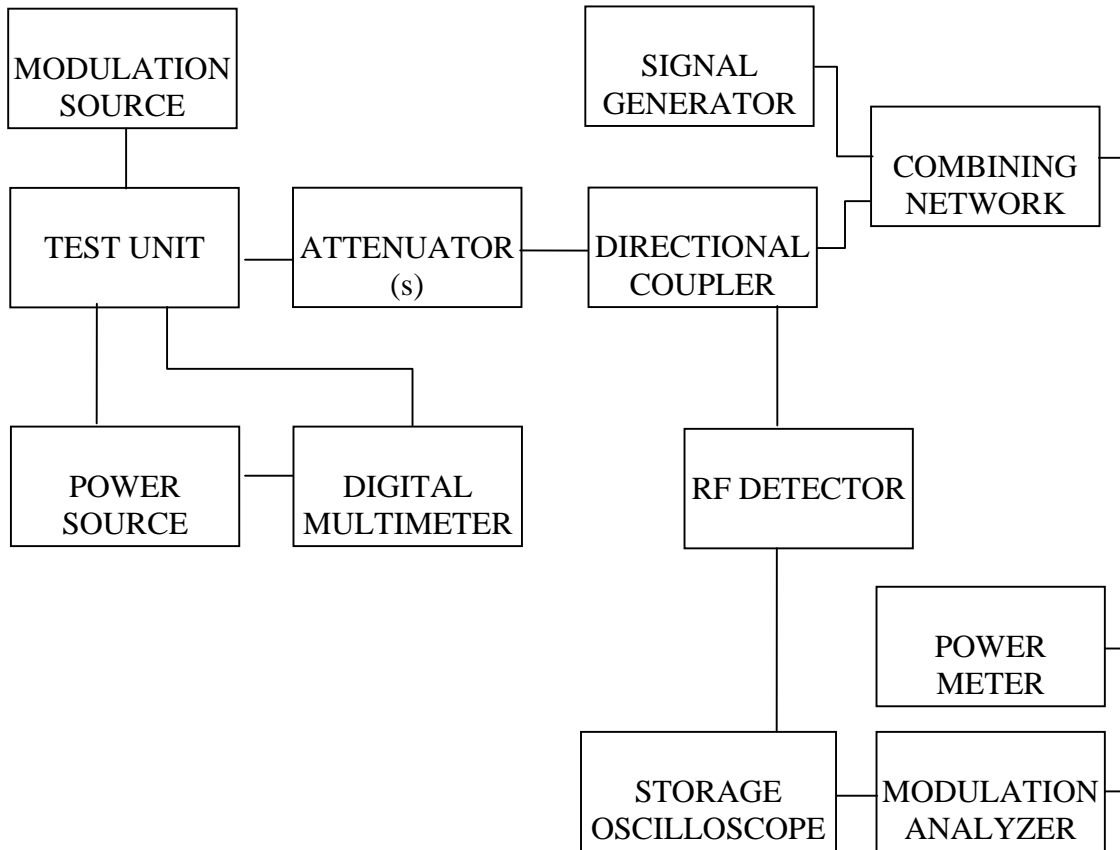

Transient Frequency Response

Frequency: 150.000000 MHz  
 Power: 5 W

Key Up

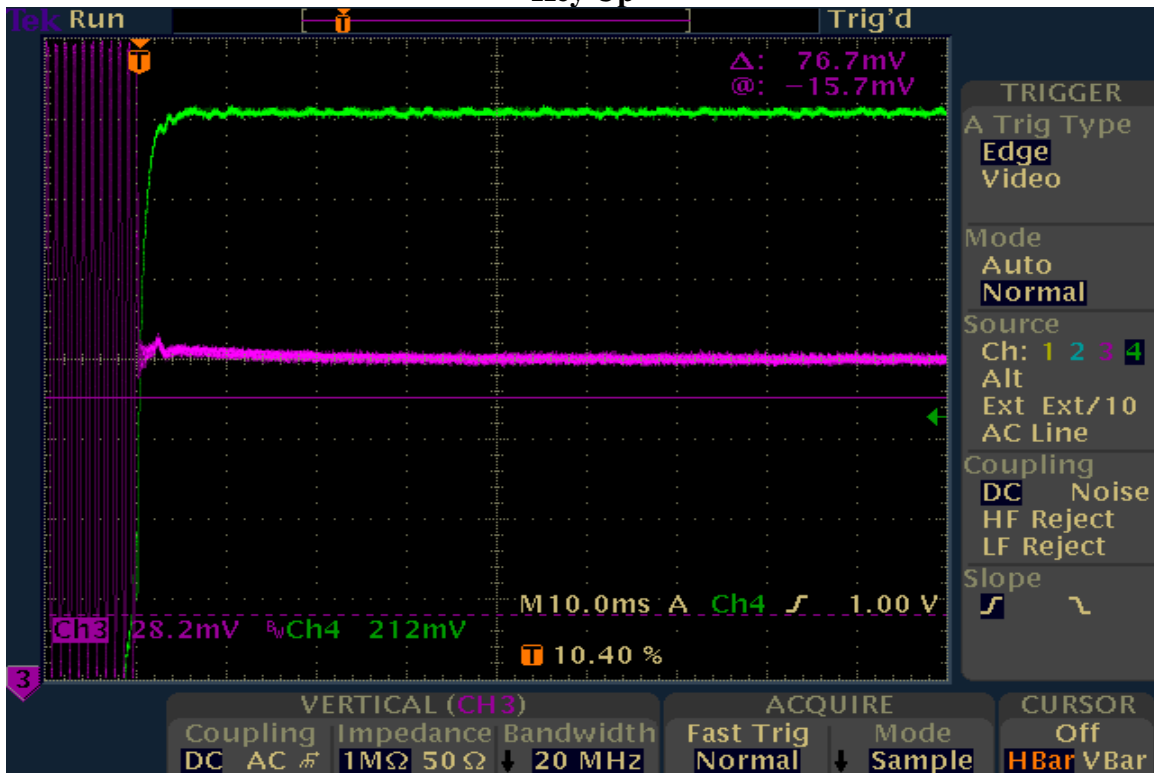

Key Down

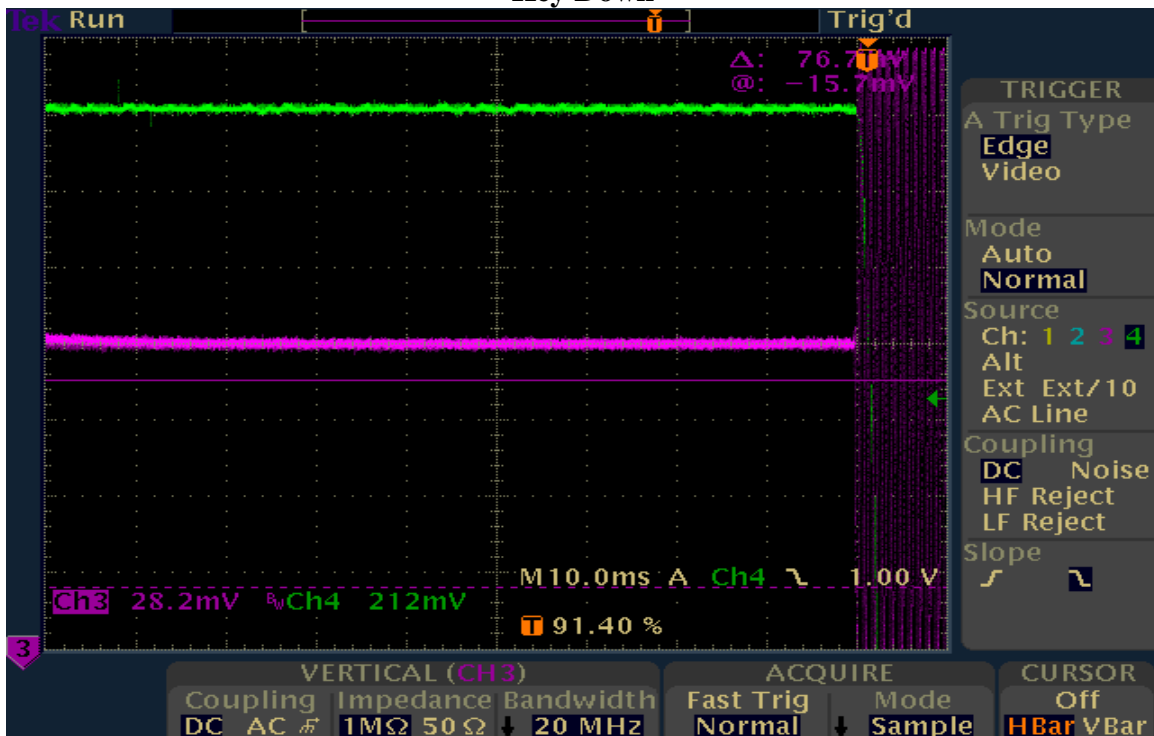

Frequency: 150.000000 MHz  
 Power 0.1W

Key Up

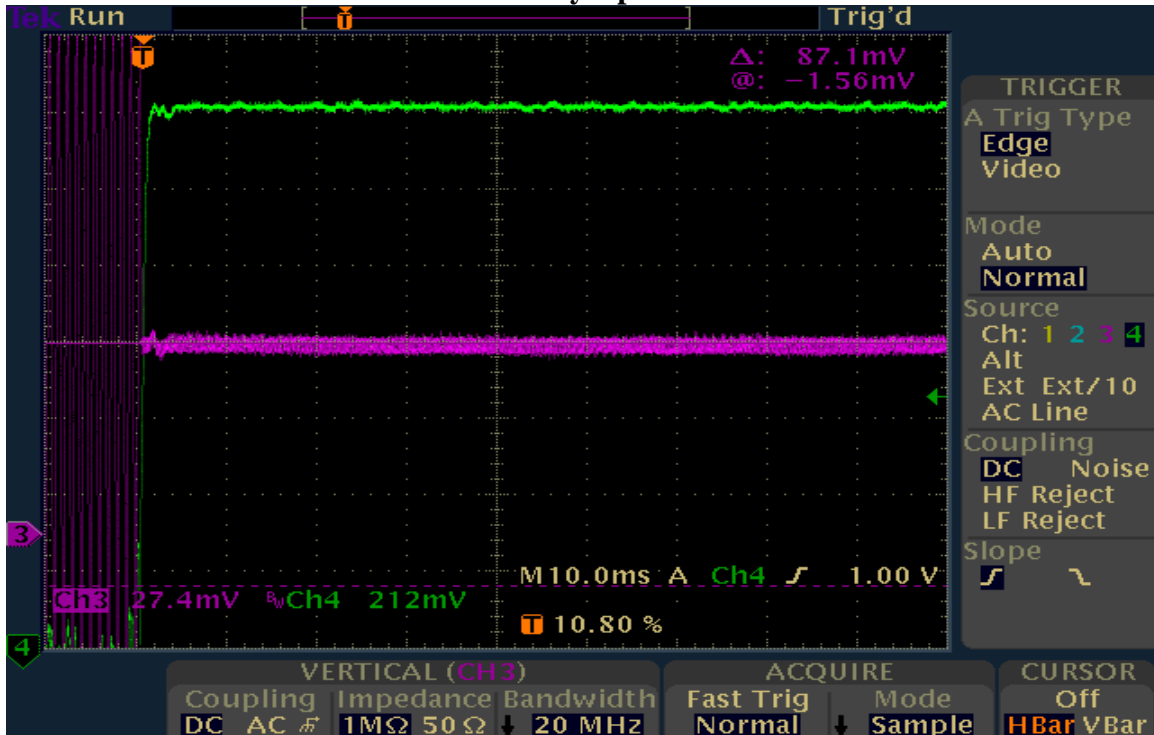

Key Down

