



InterReach Unison[®] Installation, Operation, and Reference Manual

ADCP-77-053 • Issue 2 • 9/2009



COPYRIGHT

© 2009, ADC Telecommunications, Inc.
All Rights Reserved

REVISION HISTORY

ISSUE	DATE	REASON FOR CHANGE
1	7/2008	First ADC release
2	9/2009	Add Unison 700 LTE product content

LIST OF CHANGES

The technical changes incorporated into this issue are listed below.

PAGE	IDENTIFIER	DESCRIPTION OF CHANGE
-	-	Add Unison 700 LTE product content

TRADEMARK INFORMATION

ADC is a registered trademark and InterReach, InterReach Unison, InterReach Fusion, WAVEXchange, FlexWave are registered trademarks and trademarks of ADC Telecommunications, Inc. All other products, company names, service marks, and trademarks mentioned in this document or website are used for identification purposes only and may be owned by other companies.

DISCLAIMER OF LIABILITY

Contents herein are current as of the date of publication. ADC reserves the right to change the contents without prior notice. **In no event shall ADC be liable for any damages resulting from loss of data, loss of use, or loss of profits and ADC further disclaims any and all liability for indirect, incidental, special, consequential or other similar damages. This disclaimer of liability applies to all products, publications and services during and after the warranty period.**

This publication may be verified at any time by contacting ADC's Technical Assistance Center at 1-800-366-3891, extension 73476 (in U.S.A. or Canada) or 952-917-3476 (outside U.S.A. and Canada), or by e-mail to wireless.tac@adc.com.



ADC Telecommunications, Inc.
541 E. Trimble Road, San Jose, California 95131-1224 USA
In U.S.A. and Canada: 1-800-530-9960
Outside U.S.A. and Canada: 1-408-952-2400
Fax: 1-408-952-2410

Table of Contents

SECTION 1	General Information	1-1
1.1	Firmware Release	1-2
1.2	Purpose and Scope	1-2
1.3	Conventions in this Manual	1-3
1.4	Acronyms in this Manual	1-4
1.5	Standards Conformance	1-6
1.6	Related Publications	1-6
SECTION 2	InterReach Unison System Description	2-1
2.1	System Hardware	2-3
2.2	System OA&M Capabilities	2-4
2.2.1	OA&M Software	2-7
2.2.2	Using Alarm Contacts	2-9
2.3	System Connectivity	2-11
2.4	System Operation	2-12
2.5	System Specifications	2-13
2.5.1	InterReach Unison Wavelength and Laser Power	2-14
2.5.2	Environmental Specifications	2-14
2.5.3	Operating Frequencies	2-15
2.5.4	RF End-to-End Performance	2-16
SECTION 3	Unison Main Hub	3-1
3.1	Main Hub Front Panel	3-2
3.1.1	Optical Fiber Uplink/Downlink Ports	3-3
3.1.2	Communications RS-232 Serial Connector	3-3
3.1.3	LED Indicators	3-4
3.2	Main Hub Rear Panel	3-7
3.2.1	Main Hub Rear Panel Connectors	3-8
3.3	Main Hub Specifications	3-9
3.4	Faults, Warnings, and Status Messages	3-10
3.4.1	Description	3-10

3.4.2 View Preference	3-10
-----------------------------	------

SECTION 4 Unison Expansion Hub 4-1

4.1 Expansion Hub Front Panel	4-2
4.1.1 RJ-45 Connectors	4-3
4.1.2 Optical Fiber Uplink/Downlink Connectors	4-3
4.1.3 LED Indicators	4-3
4.2 Expansion Hub Rear Panel	4-6
4.3 Faults, Warnings, and Status Messages	4-7
4.4 Expansion Hub Specifications	4-8

SECTION 5 Unison Remote Access Unit 5-1

5.1 Remote Access Unit Connectors	5-4
5.1.1 SMA Connector	5-4
5.1.2 RJ-45 Connector	5-4
5.2 LED Indicators	5-4
5.3 Faults, Warnings, and Status Messages	5-6
5.4 Remote Access Unit Specifications	5-6
5.5 RAUs in a Dual Band System	5-7

SECTION 6 Designing a Unison Solution 6-1

6.1 Maximum Output Power Per Carrier at RAU	6-3
6.1.1 700 MHz LTE	6-4
6.1.2 800 MHz Cellular	6-5
6.1.3 800 MHz iDEN/SMR	6-6
6.1.4 900 MHz GSM and EDGE	6-7
6.1.5 1800 MHz DCS	6-8
6.1.6 1900 MHz PCS	6-9
6.1.7 2.1 GHz UMTS	6-10
6.1.8 1.7/2.1 GHz AWS	6-10
6.1.9 700 MHz Public Safety	6-11
6.2 Estimating RF Coverage	6-13
6.2.1 Path Loss Equation	6-14
6.2.2 Coverage Distance	6-15
6.2.3 Examples of Design Estimates	6-21
6.3 System Gain	6-25
6.3.1 System Gain (Loss) Relative to ScTP Cable Length	6-25
6.4 Link Budget Analysis	6-26
6.4.1 Elements of a Link Budget for Narrowband Standards	6-26
6.4.2 Narrowband Link Budget Analysis for a Microcell Application	6-29
6.4.3 Elements of a Link Budget for CDMA Standards	6-31
6.4.4 CDMA Link Budget Analysis for a Microcell Application	6-34
6.4.5 Considerations for Re-Radiation (Over-the-Air) Systems	6-37
6.5 Optical Power Budget	6-38

6.6	Connecting a Main Hub to a Base Station	6-39
6.6.1	Attenuation	6-40
6.6.2	Uplink Attenuation	6-41
6.6.3	RAU Attenuation and ALC	6-43
6.7	Designing for a Neutral Host System	6-46

SECTION 7 Installing Unison 7-1

7.1	Installation Requirements	7-1
7.1.1	Component Location Requirements	7-2
7.1.2	Cable and Connector Requirements	7-2
7.1.3	Multiple Operator System Recommendations	7-2
7.1.4	Distance Requirements	7-2
7.2	Safety Precautions	7-4
7.2.1	Installation Guidelines	7-4
7.2.2	General Safety Precautions	7-4
7.2.3	Fiber Port Safety Precautions	7-5
7.3	Preparing for System Installation	7-6
7.3.1	Pre-Installation Inspection	7-6
7.3.2	Installation Checklist	7-6
7.3.3	Tools and Materials Required	7-9
7.3.4	Optional Accessories	7-9
7.4	Unison Component Installation Procedures	7-11
7.4.1	Installing a Main Hub	7-13
7.4.2	Installing Expansion Hubs	7-18
7.4.3	Installing RAUs	7-23
7.4.4	Installing a Dual-Band RAU Configuration	7-27
7.4.5	Using a Cat-5 Extender	7-29
7.4.6	Configuring the System	7-30
7.5	Splicing Fiber Optic Cable	7-33
7.5.1	Fusion Splices	7-33
7.6	Interfacing a Main Hub to a Base Station or a Roof-top Antenna	7-35
7.6.1	Connecting Multiple Main Hubs	7-38
7.7	Connecting Contact Alarms to a Unison System	7-42
7.7.1	Alarm Source	7-43
7.7.2	Alarm Sense	7-46
7.7.3	Alarm Cables	7-49
7.8	Alarm Monitoring Connectivity Options	7-51
7.8.1	Direct Connection	7-51
7.8.2	Modem Connection	7-52
7.8.3	RS-232 Port Expander Connection	7-53
7.8.4	POTS Line Sharing Switch Connection	7-54
7.8.5	Ethernet and ENET/RS-232 Serial Hub Connection	7-55
7.8.6	Network Interface Unit (NIU)	7-56

SECTION 8	Replacing Unison Components	8-1
8.1	Replacing an RAU	8-1
8.2	Replacing an Expansion Hub	8-3
8.3	Replacing a Main Hub	8-4
SECTION 9	Maintenance, Troubleshooting, and Technical Assistance	9-1
9.1	Service	9-1
9.2	Maintenance	9-2
9.3	Troubleshooting	9-3
9.3.1	Troubleshooting using AdminManager	9-4
9.3.2	Troubleshooting using LEDs	9-27
9.4	Troubleshooting CAT-5/5E/6	9-31
9.5	Technical Assistance	9-33
APPENDIX A	Cables and Connectors	A-1
A.1	CAT-5E/6 Cable (ScTP)	A-1
A.2	Fiber Optical Cables	A-3
A.3	Coaxial Cable	A-3
A.4	Standard Modem Cable	A-3
A.5	DB-9 to DB-9 Null Modem Cable	A-4
A.6	DB-25 to DB-9 Null Modem Cable	A-5
APPENDIX B	Compliance	B-1
B.1	Unison System Approval Status	B-1
B.2	Human Exposure to RF	B-3
APPENDIX C	Changes and New Capabilities	C-1
C.1	New in Rev. M of Manual	C-1
C.2	New in Rev. L of Manual	C-1
C.3	New in Rev. K of Manual	C-1
C.4	New in Rev. J of Manual	C-1
C.5	New in Rev. H. of Manual	C-2
C.6	New in Rev. G of Manual	C-2
C.7	New in Rev. F of Manual	C-2
C.8	New in Rev. E of Manual	C-2
C.9	New in Rev. D of Manual	C-3
C.10	New in Rev. C of Manual	C-3
C.11	New in Rev. B of Manual	C-3
APPENDIX D	Glossary	D-1

List of Figures

Figure 2-1	Unison System Hardware	2-3
Figure 2-2	OA&M Communications	2-4
Figure 2-3	Local System Monitoring and Reporting	2-7
Figure 2-4	Remote System Monitoring and Reporting	2-8
Figure 2-5	Alarm Source	2-9
Figure 2-6	Alarm Sense.	2-10
Figure 2-7	Unison's Double Star Architecture	2-11
Figure 2-8	Downlink (Base Station to Wireless Devices)	2-12
Figure 2-9	Uplink (Wireless Devices to Base Station)	2-12
Figure 3-1	Main Hub in a Unison System	3-1
Figure 3-2	Main Hub Block Diagram	3-1
Figure 3-3	Main Hub Front Panel	3-2
Figure 3-4	Main Hub Rear Panel	3-7
Figure 4-1	Expansion Hub in a Unison System	4-1
Figure 4-2	Expansion Hub Block Diagram	4-1
Figure 4-3	Expansion Hub Front Panel	4-2
Figure 4-4	Expansion Hub Rear Panel	4-6
Figure 5-1	Remote Access Unit in a Unison System	5-1
Figure 5-2	Remote Access Unit Block Diagram	5-2
Figure 5-3	Dual-Port Antenna Configuration	5-7
Figure 6-1	Determining Path Loss between the Antenna and the Wireless Device	6-13
Figure 6-2	Connecting Main Hubs to a Simplex Base Station	6-39
Figure 6-3	Main Hub to Duplex Base Station or Repeater Connections	6-40
Figure 6-4	ALC Operation	6-43
Figure 7-1	Mounting Bracket Detail	7-13
Figure 7-2	Mounting Bracket Installation	7-19
Figure 7-3	800 MHz Spectrum	7-24
Figure 7-4	Guideline for Unison RAU Antenna Placement	7-24

Figure 7-5	Dual Band RAU Configuration	7-28
Figure 7-6	Dual-Port Antenna Configuration	7-29
Figure 7-7	Simplex Base Station to a Main Hub	7-35
Figure 7-8	Duplex Base Station to a Main Hub	7-36
Figure 7-9	Connecting a Main Hub to Multiple Base Stations	7-37
Figure 7-10	Connecting Two Main Hubs to a Simplex Repeater or Base Station	7-39
Figure 7-11	Connecting Two Main Hubs to a Duplex Repeater or Base Station	7-41
Figure 7-12	Connecting FlexWave to Unison	7-43
Figure 7-13	Using a BTS to Monitor Unison	7-44
Figure 7-14	Using a BTS and <i>OpsConsole</i> to Monitor Unison	7-45
Figure 7-15	Connecting LGCell to Unison	7-46
Figure 7-16	Alarm Sense Contacts	7-46
Figure 7-17	5-port Alarm Daisy-Chain Cable	7-49
Figure 7-18	Alarm Sense Adapter Cable	7-50
Figure 7-19	OA&M Direct Connection	7-51
Figure 7-20	OA&M Modem Connection	7-52
Figure 7-21	OA&M Connection using an RS-232 Port Expander	7-53
Figure 7-22	OA&M Connection using a POTS Line Sharing Switch	7-54
Figure 7-23	Cascading Line Sharing Switches	7-54
Figure 7-24	OA&M Connection using Ethernet and ENET/232 Serial Hub	7-55
Figure 7-25	Network Interface Unit (NIU) Configuration Options	7-56
Figure 7-26	Multiple Unison Systems Monitored by a Single Network Management System	7-57
Figure A-1	Wiring Map for Cat-5E/6 Cable	A-2
Figure A-2	Standard Modem Cable Pinout	A-3
Figure A-3	DB-9 Female to DB-9 Female Null Modem Cable Diagram	A-4
Figure A-4	DB-25 Male to DB-9 Female Null Modem Cable Diagram	A-5

List of Tables

Table 1-1	Type Style Conventions	1-3
Table 2-1	AdminManager and OpsConsole Functional Differences	2-5
Table 2-2	AdminManager and OpsConsole Connectivity Differences	2-6
Table 2-3	System Specifications	2-13
Table 2-4	InterReach Unison Wavelength and Laser Power	2-14
Table 2-5	Environmental Specifications	2-14
Table 2-6	Operating Frequencies	2-15
Table 2-7	Cellular RF End-to-End Performance	2-16
Table 2-8	iDEN RF End-to-End Performance	2-16
Table 2-9	GSM/EGSM RF End-to-End Performance	2-17
Table 2-10	DCS RF End-to-End Performance	2-17
Table 2-11	PCS RF End-to-End Performance	2-18
Table 2-12	UMTS RF End-to-End Performance**	2-18
Table 2-13	AWS RF End-to-End Performance	2-19
Table 2-14	Public Safety 700 MHz RF End-to-End Performance	2-19
Table 2-15	700 MHz (Upper C) RF End-to-End Performance	2-20
Table 3-1	Main Hub Status LED States	3-5
Table 3-2	Main Hub Port LED States	3-6
Table 3-3	9-pin D-sub Connector Functions	3-8
Table 3-4	Main Hub Specifications	3-9
Table 4-1	Expansion Hub Unit Status and DL/UL Status LED States	4-4
Table 4-2	Expansion Hub Port LED States	4-5
Table 4-3	DB-9 Pin Connectors	4-6
Table 4-4	Expansion Hub Specifications	4-8
Table 5-1	Frequency Bands covered by Unison RAUs	5-3
Table 5-2	Remote Access Unit LED States	5-5
Table 5-3	Remote Access Unit Specifications	5-6
Table 6-1	700 MHz Power per Carrier	6-4

Table 6-2	Cellular Power per Carrier	6-5
Table 6-3	iDEN/SMR Power per Carrier	6-6
Table 6-4	GSM and EDGE Power per Carrier	6-7
Table 6-5	DCS Power per Carrier	6-8
Table 6-6	PCS Power per Carrier	6-9
Table 6-7	UMTS Power per Carrier**	6-10
Table 6-8	AWS Power per Carrier	6-10
Table 6-9	Public Safety 700 MHz Power per Carrier	6-11
Table 6-10	900 MHz Paging/SMR/iDEN	6-11
Table 6-11	800 MHz Cellular/1900 MHz PCS Power per Carrier	6-12
Table 6-12	Coaxial Cable Losses (Lcoax)	6-13
Table 6-13	Average Signal Loss of Common Building Materials	6-14
Table 6-14	Estimated Path Loss Slope for Different In-Building Environments	6-15
Table 6-15	Frequency Bands and the Value of the first Term in Equation (3)	6-16
Table 6-16	Approximate Radiated Distance from Antenna for 700 MHz LTE Applications	6-16
Table 6-17	Approximate Radiated Distance from Antenna for 800 MHz Cellular Applications	6-17
Table 6-18	Approximate Radiated Distance from Antenna for 800 MHz iDEN Applications	6-17
Table 6-19	Approximate Radiated Distance from Antenna for 900 MHz GSM Applications	6-17
Table 6-20	Approximate Radiated Distance from Antenna for 900 MHz EGSM Applications	6-17
Table 6-21	Approximate Radiated Distance from Antenna for 1800 MHz DCS Applications	6-19
Table 6-22	Approximate Radiated Distance from Antenna for 1800 MHz CDMA (Korea) Applications	6-19
Table 6-23	Approximate Radiated Distance from Antenna for 1900 MHz PCS Applications	6-19
Table 6-24	Approximate Radiated Distance from Antenna for 2.1 GHz UMTS Applications	6-19
Table 6-25	Approximate Radiated Distance from Antenna for 1.7/2.1 GHz AWS Applications	6-20
Table 6-26	Approximate Radiated Distance from Antenna for 700 MHz Public Safety Applications	6-20
Table 6-27	System Gain (Loss) Relative to ScTP Cable Length	6-25
Table 6-28	Link Budget Considerations for Narrowband Systems	6-27
Table 6-29	Narrowband Link Budget Analysis: Downlink	6-29
Table 6-30	Narrowband Link Budget Analysis: Uplink	6-30

Table 6-31	Distribution of Power within a CDMA Signal	6-31
Table 6-32	Additional Link Budget Considerations for CDMA	6-32
Table 6-33	CDMA Link Budget Analysis: Downlink	6-34
Table 6-34	CDMA Link Budget Analysis: Uplink	6-36
Table 6-35	Frequency Bands Adjacent to System Configured Bands	6-45
Table 6-36	Unison Capacity: Equal Coverage Areas	6-48
Table 7-1	Unison Distance Requirements	7-3
Table 7-2	Installation Checklist	7-6
Table 7-3	Tools and Materials Required for Component Installation	7-9
Table 7-4	Optional Accessories for Component Installation	7-9
Table 7-5	Troubleshooting Main Hub LEDs During Installation	7-16
Table 7-6	Troubleshooting Expansion Hub LEDs During Installation	7-22
Table 7-7	Troubleshooting RAU LEDs During Installation	7-26
Table 7-8	Maximum/Minimum Cable Lengths	7-30
Table 7-9	Alarm Types	7-42
Table 7-10	Pin Connections	7-47
Table 7-11	Input Electrical Characteristics	7-47
Table 7-12	Output Electrical Characteristics	7-48
Table 9-1	Faults Reported by the Main Hub	9-6
Table 9-2	Faults Reported by the Expansion Hub	9-10
Table 9-3	Faults Reported by the RAU	9-16
Table 9-4	Warnings Reported by the Main Hub	9-17
Table 9-5	Warnings Reported by the Expansion Hub	9-20
Table 9-6	Warnings Reported by the RAU	9-21
Table 9-7	Status Messages Reported by the Main Hub	9-22
Table 9-8	Status Messages Reported by the Expansion Hub	9-24
Table 9-9	Status Messages Reported by the RAU	9-26
Table 9-10	Troubleshooting Main Hub Port LEDs During Normal Operation	9-27
Table 9-11	Troubleshooting Main Hub Status LEDs During Normal Operation	9-28
Table 9-12	Troubleshooting Expansion Hub Port LEDs During Normal Operation	9-29
Table 9-13	Troubleshooting Expansion Hub Status LEDs During Normal Operation	9-30
Table 9-14	Summary of Cat-5/5E/6 Cable Wiring Problems	9-31
Table A-1	CAT-5E/6 Twisted Pair Assignment	A-1
Table A-2	DB-9 Female to DB-9 Female Null Modem Cable Pinout	A-4
Table A-3	DB-25 Male to DB-9 Female Null Modem Cable Pinout	A-5



This page is intentionally left blank.

General Information

This section contains the following subsections:

- Section 1.1 Firmware Release 1-2
- Section 1.2 Purpose and Scope 1-2
- Section 1.3 Conventions in this Manual 1-3
- Section 1.4 Acronyms in this Manual 1-4
- Section 1.5 Standards Conformance 1-6
- Section 1.6 Related Publications 1-6

1.1 Firmware Release

For the latest Firmware Release and associated documentation, access the ADC customer portal at adc.com.

1.2 Purpose and Scope

This document describes the InterReach Unison system components.

- **Section 2 InterReach Unison System Description**
This section provides an overview of the Unison hardware and OA&M capabilities. It also contains system specifications and RF end-to-end performance tables.
- **Section 3 Unison Main Hub**
This section illustrates and describes the Main Hub. This section also includes connector and LED descriptions, communication cable (serial and null modem) pin outs, and unit specifications.
- **Section 4 Unison Expansion Hub**
This section illustrates and describes the Expansion Hub, as well as connector and LED descriptions, and unit specifications.
- **Section 5 Unison Remote Access Unit**
This section illustrates and describes the Remote Access Unit, as well as connector and LED descriptions, and unit specifications.
- **Section 6 Designing a Unison Solution**
This section provides tools to aid you in designing your Unison system, including tables of the maximum output power per carrier at the RAU and formulas and tables for calculating path loss, coverage distance, and link budget.
- **Section 7 Installing Unison**
This section contains installation procedures, requirements, safety precautions, and checklists. The installation procedures include guidelines for troubleshooting using the LEDs as you install the units.
- **Section 8 Replacing Unison Components**
This section provides installation procedures and considerations when you are replacing a Unison component in an operating system.
- **Section 9 Maintenance, Troubleshooting, and Technical Assistance**
This section contains contact information and troubleshooting tables.

- Appendix A Cables and Connectors
This appendix contains connector and cable descriptions and requirements, as well as cable pin outs and diagrams.
- Appendix B Compliance
This appendix lists safety and Radio/EMC approvals.
- Appendix C Changes and New Capabilities¹
This appendix contains a hardware/firmware/software compatibility.
- Appendix D Glossary
The Glossary provides definitions of commonly-used RF and wireless networking terms.

1.3 Conventions in this Manual

Table 1-1 lists the type style conventions used in this manual.

Table 1-1 Type Style Conventions

Convention	Description
bold	Used for emphasis
BOLD CAPS	Labels on equipment
SMALL CAPS	AdminManager window buttons

Measurements are listed first in metric units, followed by U.S. Customary System of units in parentheses. For example:

0° to 45°C (32° to 113°F)

The following symbols highlight certain information as described.

NOTE: This format emphasizes text with special significance or importance, and provides supplemental information.

1. For Japan, refer to the separate addendum: *Japan Specification Document*



CAUTION: This format is used when a given action or omitted action can cause or contribute to a hazardous condition. Damage to the equipment can occur.



WARNING: This format is used when a given action or omitted action can result in catastrophic damage to the equipment or cause injury to the user.

 **Procedure**

This format highlights a procedure.

1.4 Acronyms in this Manual

Acronym	Definition
AGC	automatic gain control
ALC	automatic level control
AMPS	Advanced Mobile Phone Service
AWS	Advanced Wireless Services
BTS	base transceiver station
Cat-5/6	Category 5 or Category 6 (twisted pair cable)
CDMA	code division multiple access
CDPD	cellular digital packet data
DAS	distributed antenna system
dB	decibel
dBm	decibels relative to 1 milliwatt
DC	direct current
DCS	Digital Communications System
DL	downlink
EDGE	Enhanced Data Rates for Global Evolution
EGSM	Extended Global Standard for Mobile Communications
EH	Expansion Hub
GHz	gigahertz
GPRS	General Packet Radio Service

Acronym	Definition
GSM	Groupe Speciale Mobile (now translated in English as Global Standard for Mobile Communications)
Hz	hertz
IF	intermediate frequency
iDEN	Integrated Digital Enhanced Network (Motorola variant of TDMA wireless)
LAN	local area network
LO	local oscillator
LTE	Long Term Evolution
mA	milliamps
MBS	microcellular base station
MH	Main Hub
MHz	megahertz
MMF	multi-mode fiber
MTBF	mean time between failures
NF	noise figure
nm	nanometer
OA&M	operation, administration, and maintenance
PCS	Personal Communication Services
PLL	phase-locked loop
PLS	path loss slope
PS	Public Safety
RAU	Remote Access Unit
RF	radio frequency
RSSI	received signal strength indicator
SC/APC	fiber optic connector complying with NTT SC standard, angle-polished
SMA	sub-miniature A connector (coaxial cable connector type)
SMF	single-mode fiber
ST	straight tip (fiber optic cable connector type)
ScTP	screened twisted pair
TDMA	time division multiple access
UL	uplink; Underwriters Laboratories
uW	microwatts
UMTS	Universal Mobile Telecommunications System
UPS	uninterruptable power supply
W	watt
WCDMA	wideband code division multiple access

1.5 Standards Conformance

- Utilizes the TIA/EIA 568-A Ethernet cabling standards for ease of installation.
- Refer to Appendix B for compliance information.

1.6 Related Publications

- *AdminManager User Manual*, ADC part number 8810-10
- *OpsConsole User Manual*; ADC part number 8800-10
- *FlexWave Focus Configuration, Installation, and Reference Manual*; ADC part number 8500-10
- *LGCell Version 4.0 Installation, Operation, and Reference Manual*; ADC part number 8100-50
- *Neutral Host System Planning Guide*; ADC part number 9000-10
- *Unison Release 5.1 Field Note*, ADC FN03-007 (formerly, FN-024)
- *Unison Release 5.4 Field Note*, ADC FN04-002
- *Unison Release 5.5 Field Note*, ADC FN04-004
- *Unison Release 5.6 Field Note*, ADC FN05-001
- *Unison Release 5.7.1 Field Note*, ADC FN06-001
- *Unison Release 5.8 Field Note*, ADC FN08-001
- *Cat-5/5E/6 Cabling Requirements for Unison Family Field Note*, ADC FN04-001.

InterReach Unison System Description

InterReach Unison is an intelligent fiber optic/Cat-5/5E/6 wireless networking system designed to handle both wireless voice and data communications and provide high-quality, ubiquitous, seamless access to the wireless network in any public or private facility, including:

- Campus environments
- Airports
- Office buildings
- Shopping malls
- Hospitals
- Subways
- Public facilities (convention centers, sports venues, and so on.)

Unlike other wireless distribution alternatives, Unison is an intelligent, active system, using microprocessors to enable key capabilities such as software-selectable band settings, automatic gain control, ability to incrementally adjust downlink/uplink gain, end-to-end alarming of all components and the associated cable infrastructure, and a host of additional capabilities.

The Unison system supports major wireless standards and air interface protocols in use around the world, including:

- Frequencies: 700 MHz, 800 MHz, 900 MHz, 1700 MHz, 1800 MHz, 1900 MHz, 2100 MHz
- Voice Protocols: AMPS, TDMA, CDMA, GSM, iDEN, LTE
- Data Protocols: CDPD, EDGE, GPRS, WCDMA, CDMA2000, 1xRTT, EV-DO, LTE, and Paging

Key System Features

- **Superior RF performance**, particularly in the areas of IP3 and noise figure.
- **High downlink composite power** and **low uplink noise figure** for support of a large number of channels and larger coverage footprint per antenna.
- **Software configurable** Main and Expansion Hubs. Thus, the frequency band can be configured in the field.
- **Either single-mode or multi-mode fiber** can be used, supporting flexible cabling alternatives (in addition to standard Cat-5, Cat-5E, or Cat-6 screened twisted pair [ScTP]). You can select the cabling type to meet the resident cabling infrastructure of the facility and unique building topologies.
- **Extended system “reach.”** Using single-mode fiber, fiber runs can be as long as 6 kilometers (creating a total system “wingspan” of 12 kilometers). Alternately, with multi-mode fiber, fiber runs can be as long as 1.5 kilometers. The Cat-5/5E/6 ScTP cable run can be up to 100 meters recommended maximum, or up to 170 meters when using a Cat-5 Extender.
- **Flexible RF configuration capabilities**, including:
 - System gain:
 - Ability to manually set gain in 1 dB steps, from 0 to 15 dB, on both downlink and uplink.
 - RAU:
 - RAU uplink and downlink gain can be independently attenuated 10 dB.
 - Uplink level control protects the system from input overload and can be optimized for either a single operator or multiple operators/protocols.
 - VSWR check on RAU reports if there is a disconnected antenna (all RAUs except UMTS-1).
- **Firmware Updates** are downloaded (either locally or remotely) to operating systems when any modifications are made to the product, including the addition of new software capabilities/services.
- **Extensive OA&M capabilities**, including fault isolation to the field replaceable unit, automatic reporting of all fault and warning conditions, and user-friendly graphical-user interface OA&M software packages.

2.1 System Hardware

The InterReach Unison system consists of three modular components:

- 19" rack-mountable **Main Hub** (*connects to up to 4 Expansion Hubs*)
 - RF signal conversion to optical on the downlink; optical to RF on the uplink
 - Microprocessor controlled (for alarms, monitoring, and control)
 - Software configurable band
 - Simplex interface to RF source
 - System master – periodically polls all downstream units (Expansion Hubs/RAUs) for system status, and automatically reports any fault or warning conditions
- 19" rack-mountable **Expansion Hub** (*connects to up to 8 Remote Access Units*)
 - Optical signal conversion to electrical on the downlink; electrical to optical on the uplink
 - Microprocessor controlled (for alarms, monitoring, and control)
 - Software configurable band (based on command from Main Hub)
 - Supplies DC power to RAU
- **Remote Access Unit (RAU)**
 - Electrical signal conversion to RF on the downlink; RF to electrical on the uplink
 - Microprocessor controlled (for alarms, monitoring, and control)
 - Protocol/band specific units

The minimum configuration of a Unison system is one Main Hub, one Expansion Hub, and one RAU (1-1-1). The maximum configuration of a system is one Main Hub, four Expansion Hubs, and 32 RAUs (1-4-32). You can combine multiple systems to provide larger configurations.

Figure 2-1 Unison System Hardware



2.2 System OA&M Capabilities

The InterReach Unison is microprocessor controlled and contains firmware which enables much of the OA&M functionality.

Complete alarming, down to the field replaceable unit (that is, Main Hub, Expansion Hub, Remote Access Unit) and the cabling infrastructure, is available. All events occurring in a system, defined as a Main Hub and all of its associated Expansion Hubs and Remote Access Units, are automatically reported to the Main Hub. The Main Hub monitors system status and communicates that status using the following methods:

- Normally closed (NC) or normally open (NO) alarm contacts can be tied to standard alarm monitoring systems or directly to a base station for alarm monitoring.
- The Main Hub's front panel serial port connects directly to a PC (for local access) or to a modem (for remote access).

Figure 2-2 OA&M Communications

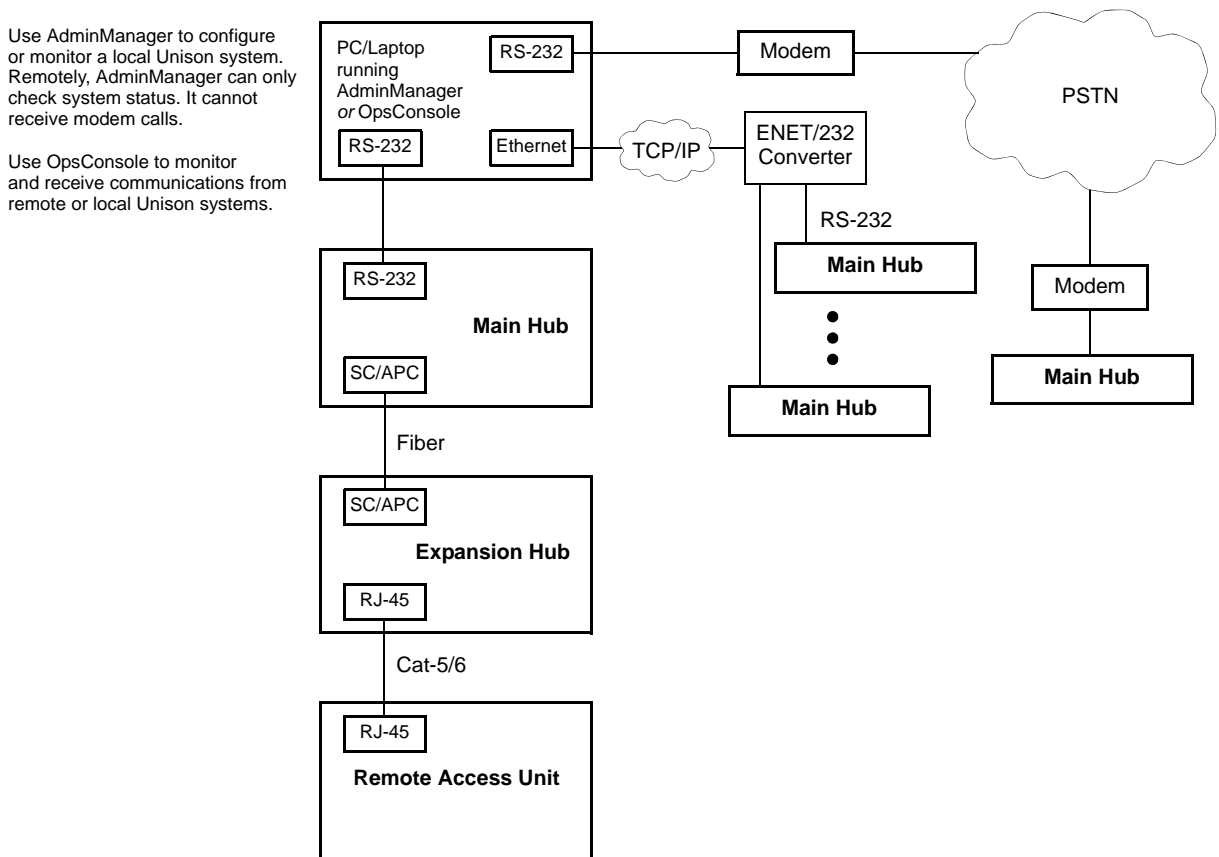

ADC offers two OA&M packages: AdminManager and OpsConsole. Both run on a PC/laptop.

- AdminManager communicates with one Main Hub, and its downstream units, at a time. Using AdminManager connected locally or remotely, you can configure a newly installed system, change system parameters, perform an end-to-end system test, or query system status.

Refer to the *AdminManager User Manual* (PN 8810-10) for information about installing and using the AdminManager software.

- OpsConsole lets you manage, monitor, and maintain multiple sites and systems from a centralized remote location. This software is described in the *OpsConsole User Guide* (PN 8800-10).

Table 2-1 lists the functional differences between AdminManager and OpsConsole.

Table 2-1 AdminManager and OpsConsole Functional Differences

Feature	AdminManager	OpsConsole
Installation Wizard	Yes	No
Local System Configuration	Yes	Yes
Remote System Configuration	Yes	Yes
Local Firmware Updating	Yes	No
Save unit information in a database	No	Yes
Network view of installed systems	Yes	Yes
Send dispatch message	No	Yes
Monitor multiple units	No	Yes
Scheduled polling	No	Yes
Windows-based GUI application	Yes	Yes
Runs on Windows 98 SE	Yes	No
Runs on Windows 2000	Yes	Yes
Installation and configuration tool	Yes	No
Operation, Administration, and Management tool	No	Yes

Table 2-2 lists connectivity differences between AdminManager and OpsConsole.

Table 2-2 AdminManager and OpsConsole Connectivity Differences

Connectivity	AdminManager	OpsConsole
Direct RS-232	Yes (COM1 through COM16)	Yes
RS-232 Expansion Board	Yes, if the expansion port is in the range of COM1 through COM16	Yes
Modem (including RF modem)	Yes	Yes
Ethernet/232 serial hub	Yes, if the remote COM port is in the range of COM1 through COM16	Yes
Line Sharing Switch after POTS	Yes	Yes

2.2.1 OA&M Software

2.2.1.1 Configuring, Maintaining, and Monitoring Unison Locally

Each Main Hub, Expansion Hub, and RAU in the system constantly monitors itself and its downstream units for internal fault and warning conditions. The results of this monitoring are stored in memory and compared against new results.

The Expansion Hubs monitor their RAUs and store their status in memory. The Main Hub monitors its Expansion Hubs and stores their status and the status of the RAUs in its memory. When a unit detects a change in status, a fault or warning is reported. Faults are indicated locally by red status LEDs, and both faults and warnings are reported to the Main Hub and displayed on a PC/laptop, using the Main Hub's serial port, that is running the AdminManager software. Passive antennas connected to the RAUs are not monitored automatically. Perform the System Test in order to retrieve status information about antennas.

Using AdminManager locally, you can install a new system or new components, change system parameters, and query system status. Figure 2-3 illustrates how the system reports its status to AdminManager.

Figure 2-3 Local System Monitoring and Reporting

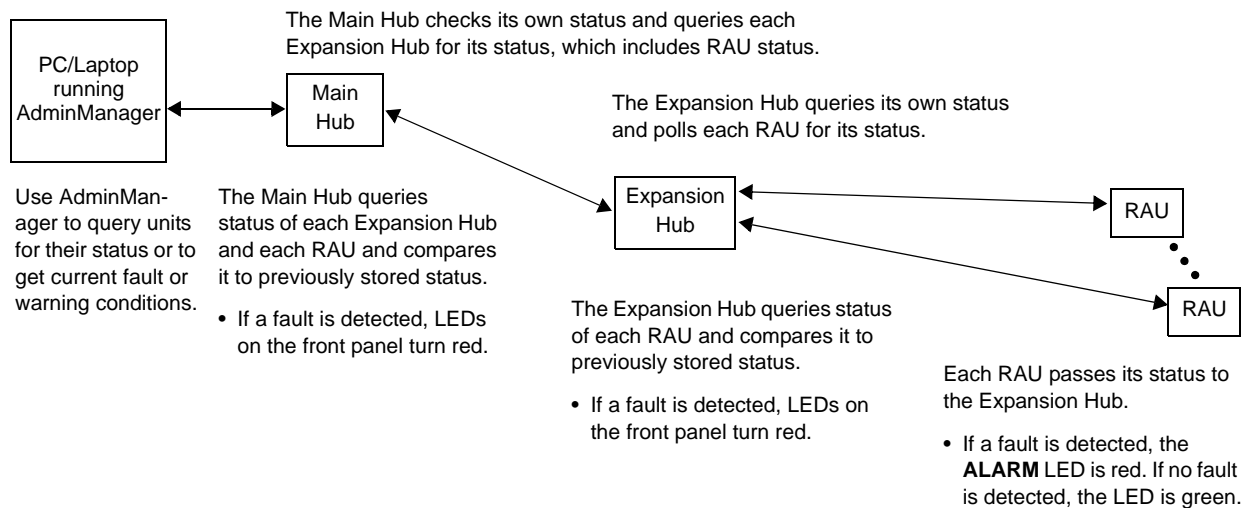

2.2.1.2 Monitoring and Maintaining Unison Remotely

- **Using AdminManager Remotely**

You can use AdminManager remotely to call into the Main Hub and query current status, change parameters, or command system end-to-end test. You cannot use AdminManager to continuously monitor system state changes.

- **Using OpsConsole Remotely**

When monitoring the system remotely, any change of state within the system causes the Main Hub to initiate an automatic call-out and report the system status to the OpsConsole. The Main Hub calls out three times, each with a 45 second interval. If the call is not acknowledged in these three tries, the Main Hub waits 15 minutes and continues the above sequence until the call is acknowledged.

Refer to the *OpsConsole User Manual* (PN 8800-10) for more information about using OpsConsole for remote system monitoring.

Figure 2-4 illustrates how the system reports its status to AdminManager and the OpsConsole.

Figure 2-4 Remote System Monitoring and Reporting

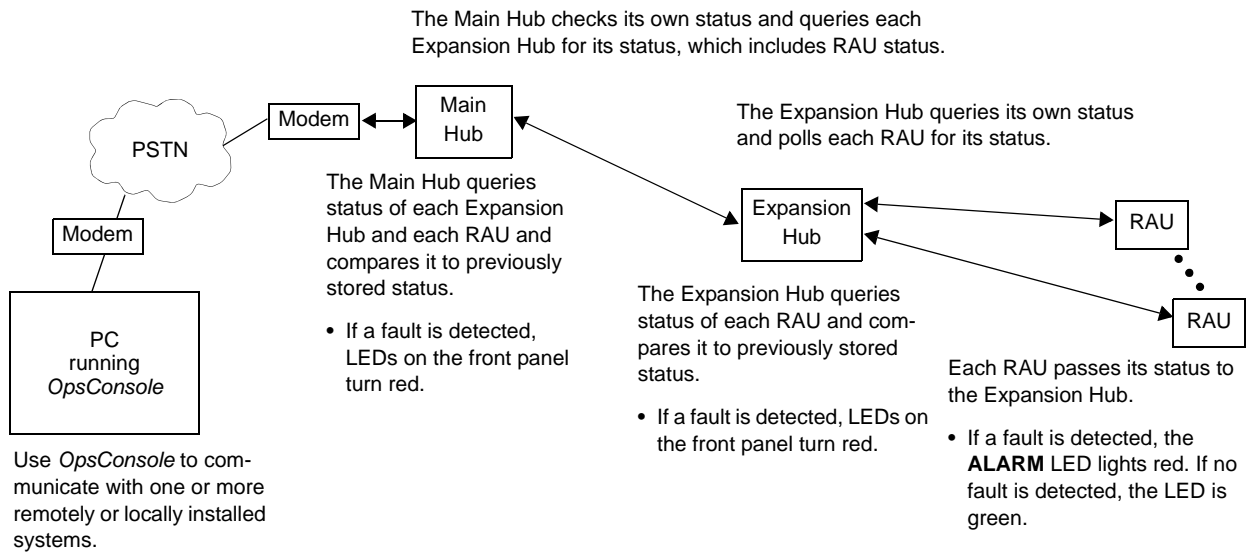

If a fault or warning condition is reported, the *OpsConsole* graphical user interface indicates the problem. *OpsConsole* can also send an e-mail and/or page notification to designated recipients.

2.2.2 Using Alarm Contacts

You can connect the DB-9 female connector on the rear panel of the Main Hub to a local base station or to a daisy-chained series of Unison, LGCell, and/or FlexWave Focus systems.

- When you connect FlexWave Focus or a BTS to Unison, the Unison Main Hub is the output of the alarms (alarm source) and FlexWave Focus or the BTS is the input (alarm sense). This is described in Section 7.7.1 on page 7-43. The following figure shows using FlexWave Focus as the input of Unison contact closures.

Figure 2-5 Alarm Source

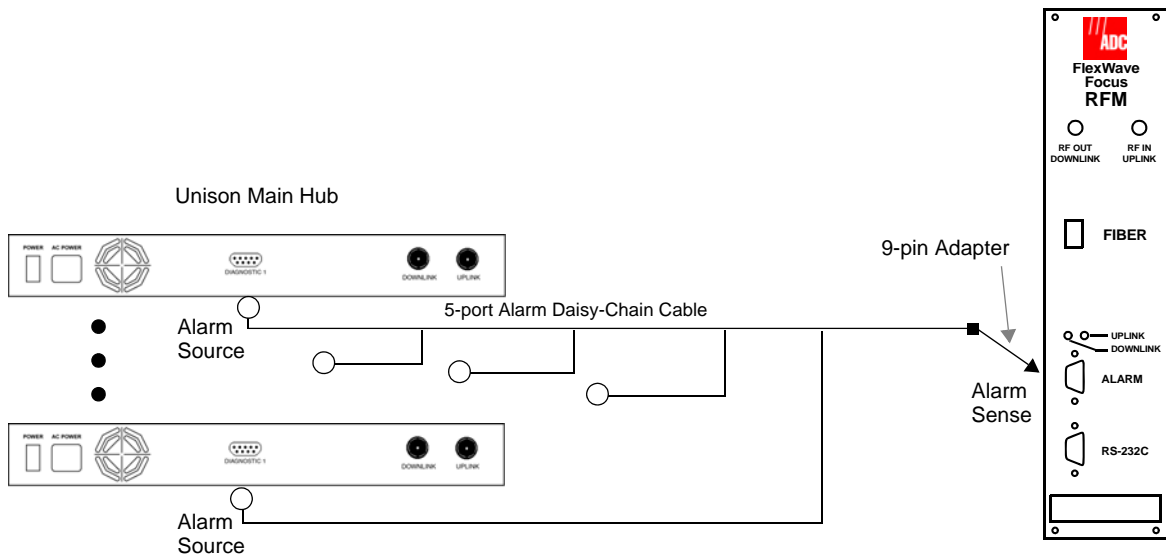

- When you connect LGCell to Unison, the Unison Main Hub is the input of the alarms (alarm sense) and LGCell is the output (alarm source). This is described in Section 7.7.2 on page 7-46

Figure 2-6 Alarm Sense.

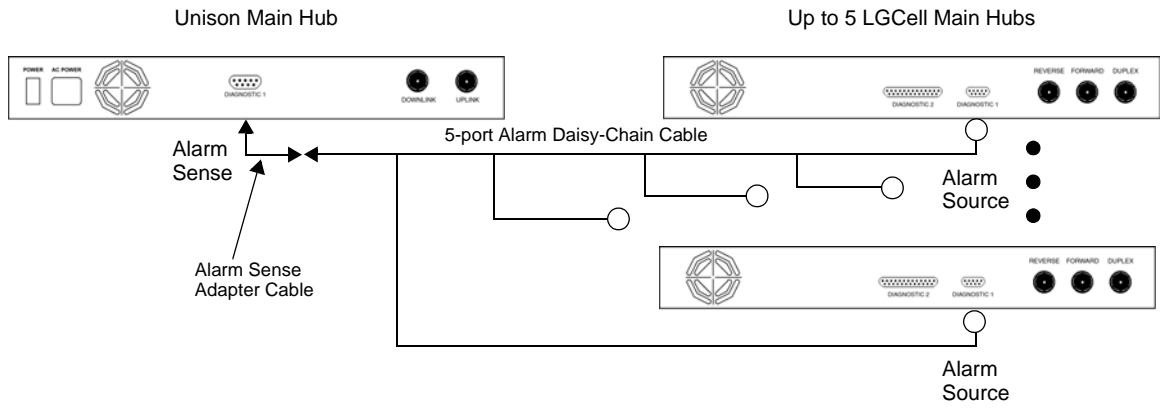

2.3 System Connectivity

The double star architecture of the Unison system, illustrated in Figure 2-7, provides excellent system scalability and reliability. The system requires only one pair of fibers for eight antenna points. This makes any system expansion, such as adding an extra antenna for additional coverage, potentially as easy as pulling an extra twisted pair.

Figure 2-7 Unison's Double Star Architecture

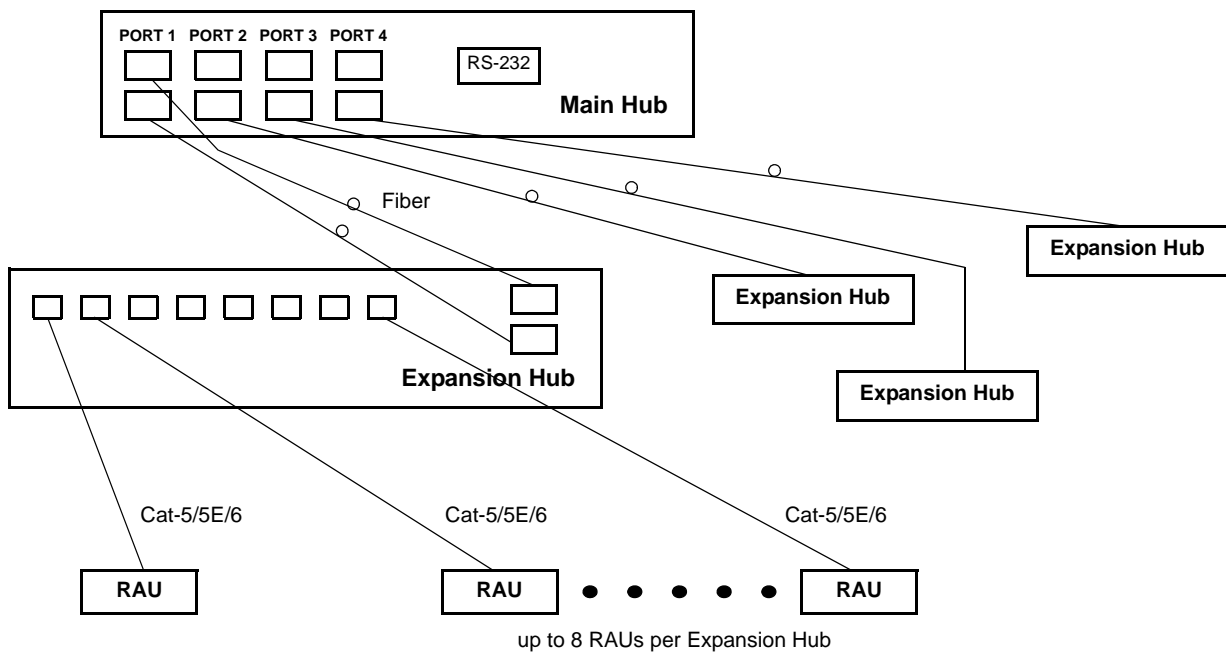

2.4 System Operation

Figure 2-8 Downlink (Base Station to Wireless Devices)

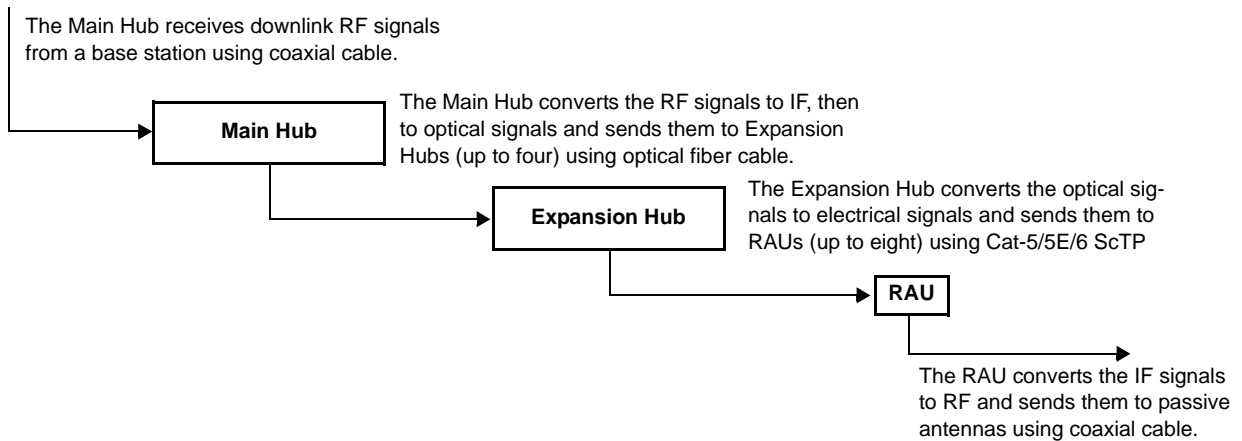
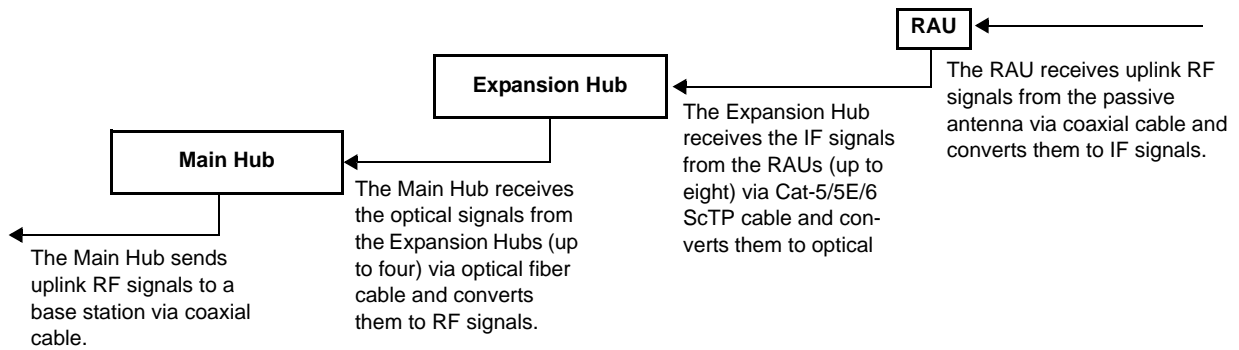

Figure 2-9 Uplink (Wireless Devices to Base Station)



2.5 System Specifications

Table 2-3 System Specifications

Parameter	Main Hub	Expansion Hub	Remote Access Unit
RF Connectors	2 N-type, female	8 shielded RJ-45, female (Cat-5/5E/6)	1 shielded RJ-45, female (Cat-5/5E/6) 1 SMA, male (coaxial)
External Alarm Connector (contact closure)	1 9-pin D-sub, female	1 9-pin D-sub, female (UNS-EH-2 only)	—
Serial Interface Connector	1 RS-232 9-pin D-sub, male	—	—
Fiber Connectors*	4 Pair, SC/APC	1 Pair, SC/APC	—
LED Alarm and Status Indicators	Unit Status (1 pair): • Power • Main Hub Status Downstream Unit Status (1 pair per fiber port): • Link • E-Hub/RAU	Unit Status (1 pair): • Power • E-Hub Status Fiber Link Status (1 pair): • DL Status • UL Status RAU/Link Status (1 pair per RJ-45 port): • Link • RAU	Unit Status (1 pair): • Link • Alarm
AC Power (Volts)**	Rating: 100–240V, 0.5A, 50–60 Hz Operating Range: 85–250V, 2.4–0.8A, 47–63 Hz	Rating: 115/230V, 5/2.5A, 50–60 Hz Operating Range: 90–132V/170–250V auto-ranging, 2.2–1.5A/1.2–0.8A, 47–63 Hz	—
DC Power (Volts)	—	—	36V (from the Expansion Hub)
Power Consumption (W)**	30	4 RAUs: 120 typ/148 max 4 RAUs & 4 Extenders: 137 typ/172 max 8 RAUs: 170 typ/212 max 8 RAUs & 8 Extenders: 204 typ/260 max	16 max (from Expansion Hub)
Enclosure Dimensions† (height × width × depth)	44.5 mm × 438 mm × 305 mm (1.75 in. × 17.25 in. × 12 in.) 1 U	89 mm × 438 mm × 305 mm (3.5 in. × 17.25 in. × 12 in.) 2 U	44 mm × 305 mm × 158 mm (1.7 in. × 12 in. × 6.2 in.)
Weight	< 3 kg (< 6.5 lb)	< 5 kg (< 11 lb)	< 1 kg (< 2 lb)
MTBF	106,272 hours	92,820 hours	282,207 hours

System Specifications

*It is critical to system performance that only SC/APC fiber connectors are used throughout the fiber network, including fiber distribution panels.

** For Japan, see separate addendum – *Japan Specification Document*.

†Excluding angle-brackets for 19" rack mounting of hubs.

Note: Expansion Hub typical power consumption assumes that the Cat-5/6 cable length is no more than 100 meters without a Cat-5 Extender and no more than 170 meters with a Cat-5 Extender.

2.5.1 InterReach Unison Wavelength and Laser Power

Table 2-4 shows wavelength and laser power according to UL testing per IEC 60825-1.

Table 2-4 InterReach Unison Wavelength and Laser Power

Wavelength	Measured Output Power	
	Main Hub	Expansion Hub
1310 nm ±20 nm	458 uW	1.8 mW

2.5.2 Environmental Specifications

Table 2-5 Environmental Specifications

Parameter	Main Hub and Expansion Hub	RAU
Operating Temperature	0° to +45°C (+32° to +113°F)	-25° to +45°C (-13° to +113°F)
Non-operating Temperature	-20° to +85°C (-4° to +185°F)	-25° to +85°C (-13° to +185°F)
Operating Humidity; non-condensing	5% to 95%	5% to 95%

2.5.3 Operating Frequencies

Table 2-6 Operating Frequencies

Freq. Band	Unison Band	Description	RF Passband	
			Downlink (MHz)	Uplink (MHz)
PCS	PCS6	A, D & B Band (35 MHz)	1930–1965	1850–1885
PCS	PCS7	D,B,E & F Band (30 MHz)	1945–1975	1865–1895
PCS	PCS8	E, F & C Band (25 MHz)	1965–1990	1885–1910
PCS	PCS9	A4/A5/D/B/E	1935-1970	1855-1890
PCS	PCS10	A5/D/B/E/F	1940-1975	1860-1895
PCS	PCS11	D/B/E/F/C2	1945-1982.5	1865-1902.5
PCS	PCS12	B4/B5/E/F/C	1955-1990	1875-1910
DCS	DCS1	DCS1 Band	1805–1842.5	1710–1747.5
DCS	DCS2	DCS2 Band	1842.5–1880	1747.5–1785
DCS	DCS4	DCS4 Band	1815–1850	1720–1755
Cellular	CELL	–	869–894	824–849
iDEN	iDEN	–	851–869	806–824
UMTS	UMTS1	–	2110–2145	1920–1955
UMTS	UMTS2	–	2125–2160	1935–1970
UMTS	UMTS3	–	2135–2170	1945–1980
UMTS	UMTS1	Japan	2110–2130	1920–1940
UMTS	UMTS2	Japan	2130–2150	1940–1960
UMTS	UMTS 3	Japan	2150–2170	1960–1980
AWS	AWS1	–	2110-2145	1710-1745
AWS	AWS2	–	2120-2155	1720-1755
PS 700	PS700	–	763-776	793-806
700 LTE	700 UC	700 (Upper C) Band	746-757	776-787

2.5.4 RF End-to-End Performance

Table 2-7 through Table 2-12 list the RF end-to-end performance of each protocol when using 2 km of single-mode fiber or 1 km of multi-mode fiber.

Cellular 800 MHz

Table 2-7 Cellular RF End-to-End Performance

Parameter	2 km of SMF		1 km of MMF	
	Typical		Typical	
	Downlink	Uplink	Downlink	Uplink
Average gain with 75 m Cat-5/5E/6 at 25°C (77°F)*	15 dB	15 dB	15 dB	15 dB
Ripple with 75 m Cat-5/5E/6	3 dB	3.5 dB	3 dB	3.5 dB
Output IP3	40 dBm		37 dBm	
Input IP3		-7 dBm		-10 dBm
Output 1 dB Compression Point	27 dBm		27 dBm	
Noise Figure with 1 MH – 1 EH – 8 RAUs configuration		15 dB		15 dB
Noise Figure with 1 MH – 4 EHs – 32 RAUs configuration		21 dB		21 dB

*The system gain is adjustable in 1 dB steps from 0 to 15 dB, and the gain of each RAU can be attenuated 10 dB in one step.

iDEN 800 MHz

Table 2-8 iDEN RF End-to-End Performance

Parameter	2 km of SMF		1 km of MMF	
	Typical		Typical	
	Downlink	Uplink	Downlink	Uplink
Average gain with 75 m Cat-5/5E/6 at 25°C (77°F)*	15 dB	15 dB	15 dB	15 dB
Ripple with 75 m Cat-5/5E/6	2 dB	3 dB	2 dB	3 dB
Output IP3	38 dBm		38 dBm	
Input IP3		-7 dBm		-10 dBm
Output 1 dB Compression Point	26 dBm		26 dBm	
Noise Figure with 1 MH – 1 EH – 8 RAUs configuration		17 dB		17 dB
Noise Figure with 1 MH – 4 EHs – 32 RAUs configuration		23 dB		23 dB

*The system gain is adjustable in 1 dB steps from 0 to 15 dB, and the gain of each RAU can be attenuated 10 dB in one step.

GSM/EGSM 900 MHz

Table 2-9 GSM/EGSM RF End-to-End Performance

Parameter	2 km of SMF		1 km of MMF	
	Typical		Typical	
	Downlink	Uplink	Downlink	Uplink
Average gain with 75 m Cat-5/5E/6 at 25°C (77°F)*	15 dB	15 dB	15 dB	15 dB
Ripple with 75 m Cat-5/5E/6	3 dB	4 dB	3 dB	4 dB
Output IP3	38 dBm		38 dBm	
Input IP3		-7 dBm		-10 dBm
Output 1 dB Compression Point	26 dBm		26 dBm	
Noise Figure with 1 MH – 1 EH – 8 RAU configuration		16 dB		16 dB
Noise Figure with 1 MH – 4 EH – 32 RAU configuration		22 dB		22 dB

*The system gain is adjustable in 1 dB steps from 0 to 15 dB, and the gain of each RAU can be attenuated 10 dB in one step.

DCS 1800 MHz

Table 2-10 DCS RF End-to-End Performance

Parameter	2 km of SMF		1 km of MMF	
	Typical		Typical	
	Downlink	Uplink	Downlink	Uplink
Average gain with 75 m Cat-5/5E/6 at 25°C (77°F)*	15 dB	15 dB	15 dB	15 dB
Downlink ripple with 75 m Cat-5/5E/6	2 dB		2 dB	
Uplink ripple for center 35 MHz of DCS1 and DCS2, Full band for DCS3 & DCS4 with 75 m Cat-5/5E/6		2 dB		2 dB
Uplink gain roll off for Full band of DCS1 and DCS2 with 75 m Cat-5/5E/6		2 dB		2 dB
Output IP3	38 dBm		37 dBm	
Input IP3		-12 dBm		-14 dBm
Output 1 dB Compression Point	26 dBm		26 dBm	
Noise Figure with 1 MH – 1 EH – 8 RAU configuration		17 dB		17 dB
Noise Figure with 1 MH – 4 EH – 32 RAU configuration		23 dB		23 dB

*The system gain is adjustable in 1 dB steps from 0 to 15 dB, and the gain of each RAU can be attenuated 10 dB in one step. UNS-UMTS-2 has a 1 dB attenuator in the RAU.

PCS 1900 MHz

Table 2-11 PCS RF End-to-End Performance

Parameter	2 km of SMF		1 km of MMF	
	Typical		Typical	
	Downlink	Uplink	Downlink	Uplink
Average gain with 75 m Cat-5/5E/6 at 25°C (77°F)*	15 dB	15 dB	15 dB	15 dB
Ripple with 75 m Cat-5/5E/6	2.5 dB	3 dB	2.5 dB	3 dB
Output IP3	38 dBm		36.5 dBm	
Input IP3		-12 dBm		-14 dBm
Output 1 dB Compression Point	26 dBm		26 dBm	
Noise Figure with 1 MH – 1 EH – 8 RAUs configuration		16 dB		16 dB
Noise Figure with 1 MH – 4 EHs – 32 RAUs configuration		22 dB		22 dB

*The system gain is adjustable in 1 dB steps from 0 to 15 dB, and the gain of each RAU can be attenuated 10 dB in one step.

UMTS 2.1 GHz

Table 2-12 UMTS RF End-to-End Performance**

Parameter	2 km of SMF		1 km of MMF	
	Typical		Typical	
	Downlink	Uplink	Downlink	Uplink
Average gain with 75 m Cat-5/5E/6 at 25°C (77°F) *	15 dB	15 dB	15 dB	15 dB
Ripple with 75 m Cat-5/5E/6	2.5 dB	4 dB	2.5 dB	4 dB
Output IP3	37 dBm		36 dBm	
Input IP3		-12 dBm		-12 dBm
Output 1 dB Compression Point	26 dBm		26 dBm	
Noise Figure with 1 MH – 1 EH – 8 RAUs configuration		16 dB		16 dB
Noise Figure with 1 MH – 4 EHs – 32 RAUs configuration		22 dB		22 dB

*The system gain is adjustable in 1 dB steps from 0 to 15 dB, and the gain of each RAU can be attenuated 10 dB in one step.

** For Japan, see separate addendum – *Japan Specification Document*.

AWS 1.7/2.1 GHz**Table 2-13 AWS RF End-to-End Performance**

Parameter	2 km of SMF		1 km of MMF	
	Typical		Typical	
	Downlink	Uplink	Downlink	Uplink
Average gain with 75 m Cat-5/5E/6 at 25°C (77°F) *	15 dB	15 dB	15 dB	15 dB
Ripple with 75 m Cat-5/5E/6	2 dB	2 dB	2 dB	2 dB
Output IP3	38 dBm		36 dBm	
Input IP3		-12 dBm		-14 dBm
Output 1 dB Compression Point	26 dBm		26 dBm	
Noise Figure with 1 MH – 1 EH – 8 RAUs configuration		17 dB		17 dB
Noise Figure with 1 MH – 4 EHs – 32 RAUs configuration		23 dB		23 dB

*The system gain is adjustable in 1 dB steps from 0 to 15 dB, and the gain of each RAU can be attenuated 10 dB in one step.

Public Safety 700 MHz**Table 2-14 Public Safety 700 MHz RF End-to-End Performance**

Parameter	2 km of SMF		1 km of MMF	
	Typical		Typical	
	Downlink	Uplink	Downlink	Uplink
Average gain with 75 m Cat-5/5E/6 at 25°C (77°F) *	15 dB	15 dB	15 dB	15 dB
Ripple with 75 m Cat-5/5E/6	2 dB	3 dB	2 dB	3 dB
Output IP3	38 dBm		36 dBm	
Input IP3		-7 dBm		-10 dBm
Output 1 dB Compression Point	26 dBm		26 dBm	
Noise Figure with 1 MH – 1 EH – 8 RAUs configuration		16 dB		16 dB
Noise Figure with 1 MH – 4 EHs – 32 RAUs configuration		22 dB		22 dB

*The system gain is adjustable in 1 dB steps from 0 to 15 dB, and the gain of each RAU can be attenuated 10 dB in one step.

700 MHz LTE

Table 2-15 700 MHz (Upper C) RF End-to-End Performance

Parameter	2 km of SMF		1 km of MMF	
	Typical		Typical	
	Downlink	Uplink	Downlink	Uplink
Average gain with 75 m Cat-5/5E/6 at 25°C (77°F) *	15 dB	15 dB	15 dB	15 dB
Ripple with 75 m Cat-5/5E/6	2 dB	3 dB	2 dB	3 dB
Output IP3	38 dBm		36 dBm	
Input IP3		-7 dBm		-10 dBm
Output 1 dB Compression Point	26 dBm		26 dBm	
Noise Figure with 1 MH – 1 EH – 8 RAUs configuration		16 dB		16 dB
Noise Figure with 1 MH – 4 EHs – 32 RAUs configuration		22 dB		22 dB

*The system gain is adjustable in 1 dB steps from 0 to 15 dB, and the gain of each RAU can be attenuated 10 dB in one step.

Unison Main Hub

The Main Hub distributes downlink RF signals from a base station, repeater, or FlexWave Focus system to up to four Expansion Hubs, which in turn distribute the signals to up to 32 Remote Access Units. The Main Hub also combines uplink signals from the associated Expansion Hubs.

Figure 3-1 Main Hub in a Unison System

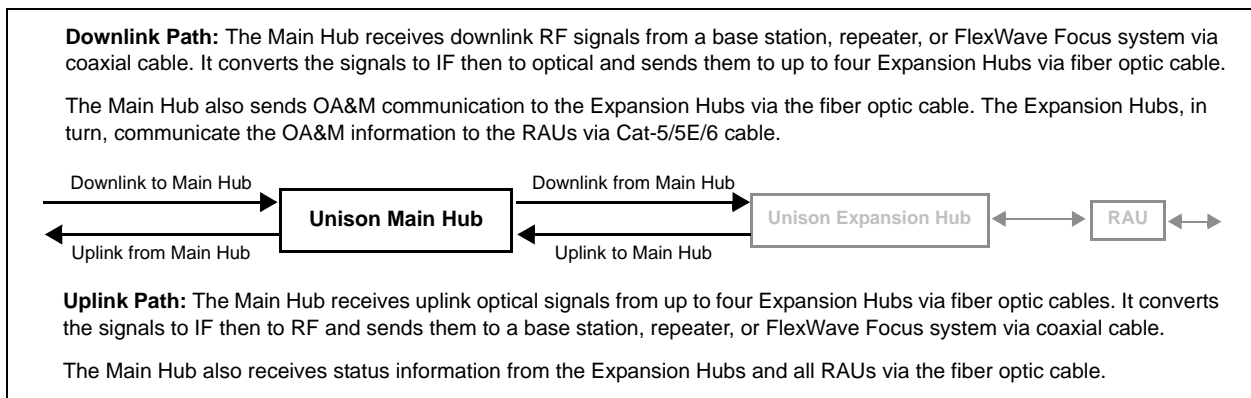
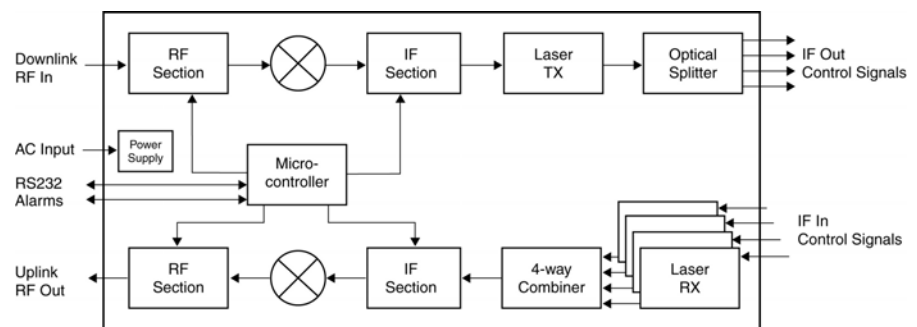

Figure 3-2 shows a detailed view of the major RF and optical functional blocks of the Main Hub.

Figure 3-2 Main Hub Block Diagram



3.1 Main Hub Front Panel

Figure 3-3 Main Hub Front Panel

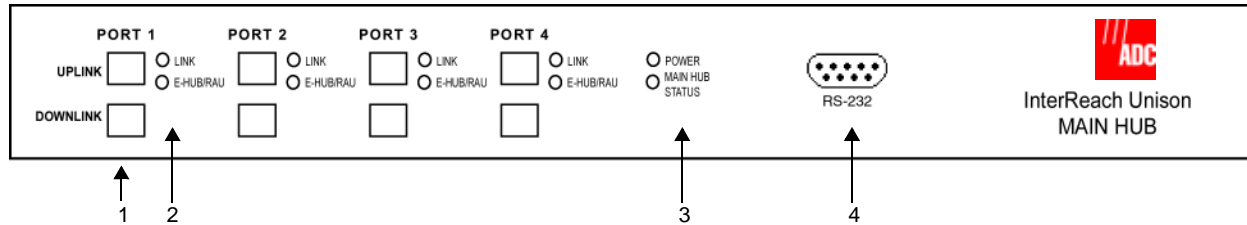

1. Four fiber optic ports (labeled **PORT 1**, **PORT 2**, **PORT 3**, **PORT 4**)
 - One standard female SC/APC connector per port for MMF/SMF input (labeled **UPLINK**)
 - One standard female SC/APC connector per port for MMF/SMF output (labeled **DOWNLINK**)
2. Four sets of fiber port LEDs (one set per port)
 - One LED per port for port link status (labeled **LINK**)
 - One LED per port for downstream unit status (labeled **E-HUB/RAU**)
3. One set of unit status LEDs
 - One LED for unit power status (labeled **POWER**)
 - One LED for unit status (labeled **MAIN HUB STATUS**)
4. One 9-pin D-sub male connector for system communication and diagnostics using a PC/laptop or modem (labeled **RS-232**)

3.1.1 Optical Fiber Uplink/Downlink Ports

The optical fiber uplink/downlink ports transmit and receive optical signals between the Main Hub and up to four Expansion Hubs using industry-standard SMF or MMF cable. There are four fiber ports on the front panel of the Main Hub; one port per Expansion Hub. Each fiber port has two female SC/APC connectors:

- **Optical Fiber Uplink Connector**

This connector (labeled **UPLINK**) is used to receive the uplink optical signals from an Expansion Hub.

- **Optical Fiber Downlink Connector**

This connector (labeled **DOWNLINK**) is used to transmit the downlink optical signals to an Expansion Hub.



CAUTION: To avoid damaging the Main Hub's fiber connector ports, use only SC/APC fiber cable connectors when using either single-mode or multi-mode fiber. Additionally, it is critical to system performance that only SC/APC fiber connectors are used throughout the fiber network, including fiber distribution panels.

3.1.2 Communications RS-232 Serial Connector

Remote Monitoring

Use a standard serial cable to connect a modem to the 9-pin D-sub male serial connector for remote monitoring or configuring. The cable typically has a DB-9 female and a DB-25 male connector. Refer to Appendix A.4 on page A-3 for the cable pinout.

Local Monitoring

Use a null modem cable to connect a laptop or PC to the 9-pin D-sub male serial connector for local monitoring or configuring. The cable typically has a DB-9 female connector on both ends. Refer to Appendix A.5 on page A-4 for the cable pinout.

3.1.3 LED Indicators

The unit's front panel LEDs indicate faults and commanded or fault lockouts. The LEDs do not indicate warnings or whether the system test has been performed. Only use the LEDs to provide basic information or as a backup when you are not using AdminManager.

Upon power up, a Main Hub goes through a five-second test to check the LED lamps. During this time, the LEDs blink through the states shown in Table 3-2, letting you visually verify that the LED lamps and the firmware are functioning properly.

Main Hubs ship without a band programmed into them. After the equipment is installed, cables connected, and powered up, an unprogrammed Main Hub LEDs displays as follows:

- **MAIN HUB STATUS LED:** Red
- **LINK LED:** Green
- **E-HUB/RAU LED:** Red

If the LEDs do not display as above, refer to Table 3-1 on page 3-5, Table 3-2 on page 3-6, and/or Section 9 for troubleshooting using the LEDs.

Unit Status LEDs

The Main Hub status LEDs can be in one of the states shown in Table 3-1. These LEDs can be:

- steady green
- steady red
- blinking green/red (alternating green/red)

There is no off state when the unit's power is on.

NOTE: AdminManager or OpsConsole must be used for troubleshooting the system. Only use LEDs as backup or for confirmation. However, if there are communications problems within the system, the LEDs may provide additional information that is not available using AdminManager.

Table 3-1 Main Hub Status LED States

	LED State	Indicates
● POWER ● MAIN HUB STATUS	Green Green	<ul style="list-style-type: none"> • The Main Hub is connected to power and all power supplies are operating. • The Main Hub is not reporting a fault; but the system test may need to be performed or a warning could exist (use AdminManager to determine).
● POWER ● MAIN HUB STATUS	Green Red	<ul style="list-style-type: none"> • The Main Hub is connected to power and all power supplies are operating. • The Main Hub is reporting a fault or lockout condition, or the band is not programmed.
● POWER ● MAIN HUB STATUS	Green Alternating Green/Red	<ul style="list-style-type: none"> • The Main Hub is connected to power and all power supplies are operating. • The Main Hub input signal level is too high.
● POWER ● MAIN HUB STATUS	Red Red	<ul style="list-style-type: none"> • One or more power supplies in the hub are out-of-specification.

Port LEDs

The Main Hub has one pair of fiber port LEDs for each of the four fiber optic ports. The LED pairs can be in one of the states shown in Table 3-2. These LEDs can be:

- off
- steady green
- steady red

The port LEDs indicate the status of the Expansion Hub and RAUs; however, they do not indicate which particular unit has a fault (that is, the Expansion Hub vs. one of its RAUs).

Table 3-2 Main Hub Port LED States

	LED State	Indicates
LINK ○ E-HUB/RAU ○	Off Off	<ul style="list-style-type: none">• The Expansion Hub is not connected.
LINK ● E-HUB/RAU ●	Green Green	<ul style="list-style-type: none">• The Expansion Hub is connected, communications are normal.• There are no faults from Expansion Hub or any connected RAU.
LINK ● E-HUB/RAU ○	Red Off	<ul style="list-style-type: none">• There was a loss of communications with the Expansion Hub.• The Expansion Hub is disconnected.
LINK ● E-HUB/RAU ●	Green Red	<ul style="list-style-type: none">• The Expansion Hub is connected.• A fault or lockout was reported by the Expansion Hub or any connected RAU.

3.2 Main Hub Rear Panel

Figure 3-4 Main Hub Rear Panel

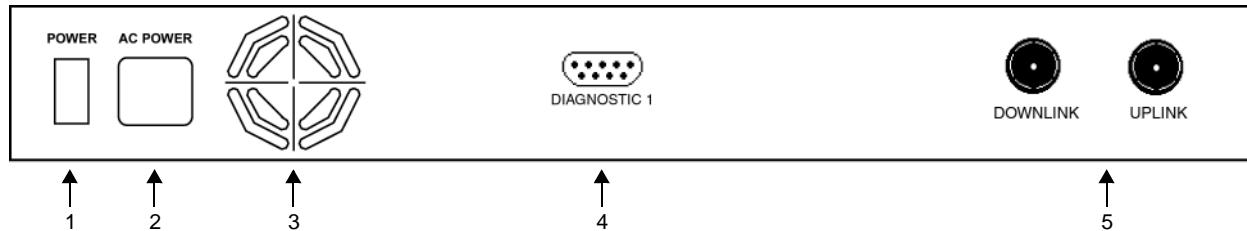

1. Power On/Off switch
2. AC power cord connector
3. Fan exhaust vent
4. One 9-pin D-sub female connector for alarm contact monitoring (labeled **DIAGNOSTIC 1**)
5. Two N-type, female connectors:
 - Downlink (labeled **DOWNLINK**)
 - Uplink (labeled **UPLINK**)

3.2.1 Main Hub Rear Panel Connectors

3.2.1.1 9-pin D-sub Connector

The 9-pin D-sub connector (labeled **DIAGNOSTIC 1**) provides contacts for fault and warning system alarm monitoring.

Table 3-3 lists the function of each pin on the 9-pin D-sub connector.

Table 3-3 9-pin D-sub Connector Functions

Pin	Function
1	Alarm Input Ground
2	Reserved
3	Reserved
4	Warning Contact (positive connection)
5	Warning Contact (negative connection)
6	DC Ground (common)
7	Fault Contact (positive connection)
8	Alarm Input
9	Fault Contact (negative connection)

This interface can both generate contact alarms and sense a single external alarm contact.

3.2.1.2 N-type Female Connectors

There are two N-type female connectors on the rear panel of the Main Hub:

- The **DOWNLINK** connector receives downlink RF signals from a repeater, local base station, or FlexWave Focus system.
- The **UPLINK** connector transmits uplink RF signals to a repeater, local base station, or FlexWave Focus system.

CAUTION: The **UPLINK** and **DOWNLINK** ports cannot handle a DC power feed from the base station. If DC power is present, a DC block must be used or the hub may be damaged.

3.3 Main Hub Specifications

Table 3-4 Main Hub Specifications

Specification**	Description
Enclosure Dimensions (H × W × D):	44.5 mm × 438 mm × 305 mm (1.75 in. × 17.25 in. × 12 in.) 1 U
Weight	< 3 kg (< 6.5 lb)
Operating Temperature**	0° to +45°C (+32° to +113°F)
Non-operating Temperature**	-20° to +85°C (-4° to +185°F)
Operating Humidity, non-condensing	5% to 95%
External Alarm Connector (contact closure)	1 9-pin D-sub, female Maximum: 40 mA @ 40V DC Typical: 4 mA @ 12V DC
Serial Interface Connector	1 RS-232 9-pin D-sub, male
Fiber Connectors	4 Pair, SC/APC ^a
RF Connectors	2 N-type, female
LED Fault and Status Indicators	Unit Status (1 pair): <ul style="list-style-type: none"> • Power • Main Hub Status Downstream Unit/Link Status (1 pair per fiber port): <ul style="list-style-type: none"> • Link • E-Hub/RAU
AC Power	Rating: 100–240V, 0.5A, 50–60 Hz Operating Range: 85–250V, 2.4–0.8A, 47–63 Hz
Power Consumption (W)	30
MTBF	106,272 hours

a. It is critical to system performance that only SC/APC fiber connectors are used throughout the fiber network, including fiber distribution panels.

** For Japan, refer to separate addendum - *Japan Specification Document*.

3.4 Faults, Warnings, and Status Messages

3.4.1 Description

The Main Hub monitors and reports changes or events in system performance to:

- Ensure that the fiber receivers, amplifiers, and IF/RF path in the Main Hub are functioning properly.
- Ensure that Expansion Hubs and Remote Access Units are connected and functioning properly.

An event is classified as a fault, warning, or status message.

- Faults are service impacting.
- Warnings indicate a possible service impact.
- Status messages are generally not service impacting.

The Main Hub periodically queries attached Expansion Hubs and their Remote Access Units for their status. Both faults and warnings are reported to a connected PC/laptop running the AdminManager software or to the optional remote OpsConsole. Only faults are indicated by LEDs.

For more information, refer to:

- page 9-6 for Main Hub faults.
- page 9-17 for Main Hub warnings.
- page 9-22 for Main Hub status messages.
- page 9-27 for troubleshooting Main Hub LEDs.

3.4.2 View Preference

AdminManager 2.04 or higher allows you to select what type of events to be displayed.

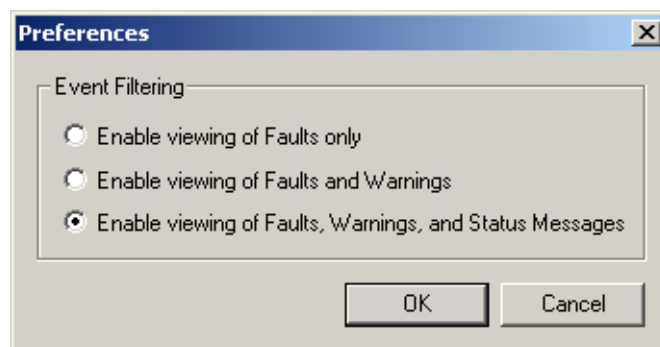

To modify the setting, select View → Preference and select the desired choice. You can change the setting either while connected to a system or offline. If there is a connection to a system, after the you click OK, AdminManager refreshes and updates the tree view according to the new setting. Note that the setting is strictly visual and only in AdminManager. There is no affect on the hardware itself. The same setting is carried with AdminManager and applied to any hardware AdminManager is connected to. By default, event filtering is set to “Enable viewing of Faults only”.

The only exception when the vent filtering is ignored is during the Install/Configure command. All events are displayed regardless of the event filtering setting. This ensures a smooth installation.

This page is intentionally left blank.

Unison Expansion Hub

The Expansion Hub interfaces between the Main Hub and the Remote Access Unit(s) by converting optical signals to electrical signals and vice versa. It also supplies control signals and DC power to operate the Remote Access Unit(s) as well as passes status information from the RAUs to the Main Hub.

Figure 4-1 Expansion Hub in a Unison System

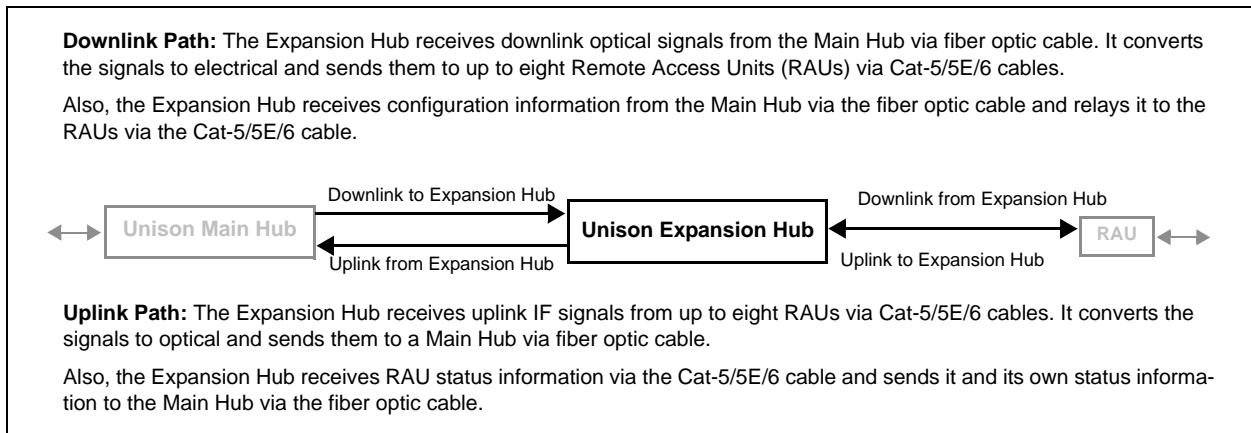
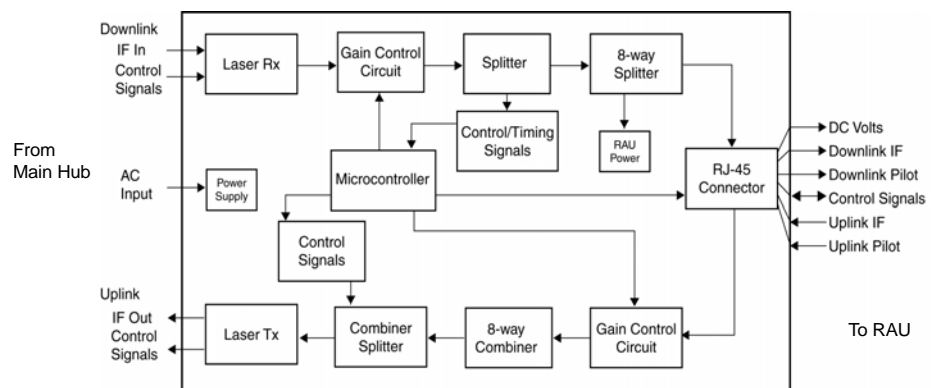
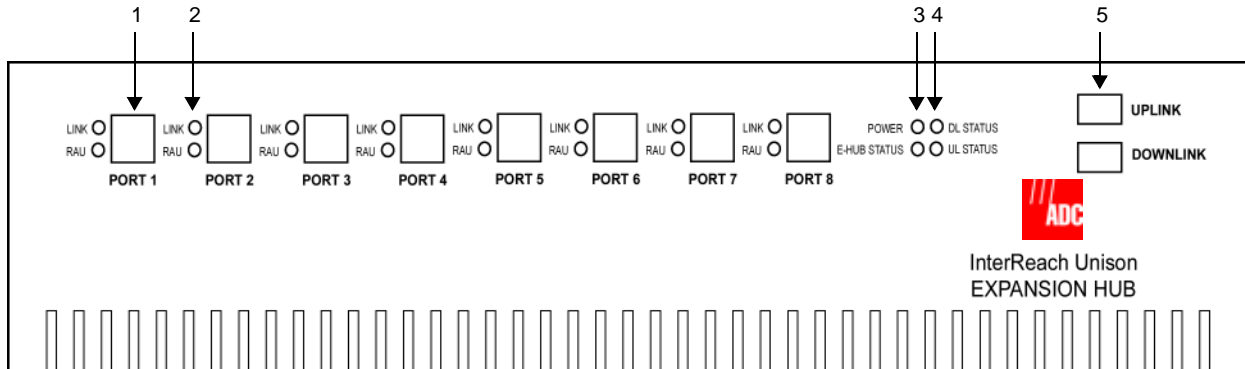

Figure 4-2 Expansion Hub Block Diagram



4.1 Expansion Hub Front Panel

Figure 4-3 Expansion Hub Front Panel



1. Eight standard Cat-5/5E/6 ScTP cable, RJ-45 shielded connectors (labeled **PORT 1, 2, 3, 4, 5, 6, 7, 8**)
2. Eight sets of RJ-45 port LEDs (one set per port)
 - One LED per port for link status (labeled **LINK**)
 - One LED per port for downstream unit status (labeled **RAU**)
3. One set of unit status LEDs
 - One LED for unit power status (labeled **POWER**)
 - One LED for unit status (labeled **E-HUB STATUS**)
4. One set of fiber connection status LEDs
 - One LED for fiber downlink status (labeled **DL STATUS**)
 - One LED for fiber uplink status (labeled **UL STATUS**)
5. One fiber optic port which has two connectors
 - One standard female SC/APC connector for MMF/SMF output (labeled **UPLINK**)
 - One standard female SC/APC connector for MMF/SMF input (labeled **DOWNLINK**)

4.1.1 RJ-45 Connectors

The eight RJ-45 connectors on the Expansion Hub are for the Cat-5/5E/6 ScTP cables used to transmit and receive signals to and from RAUs. Use shielded RJ-45 connectors on the Cat-5/5E/6 cable.

NOTE: For system performance, it is important to use only Cat-5/5E/6 ScTP (screened twisted pair) cable with shielded RJ-45 connectors.

Cat-5/5E/6 cable also delivers DC electrical power to the RAUs. The Expansion Hub's DC voltage output is 36V DC nominal. A current limiting circuit protects the Expansion Hub if any port draws excessive power.

4.1.2 Optical Fiber Uplink/Downlink Connectors

The optical fiber uplink/downlink port transmits and receives optical signals between the Expansion Hub and the Main Hub using industry-standard SMF or MMF cable. The fiber port has two female SC/APC connectors:

- **Optical Fiber Uplink Connector**

This connector (labeled **UPLINK**) is used to transmit (output) uplink optical signals to the Main Hub.

- **Optical Fiber Downlink Connector**

This connector (labeled **DOWNLINK**) is used to receive (input) downlink optical signals from the Main Hub.



CAUTION: To avoid damaging the Expansion Hub's fiber connector ports, use only SC/APC fiber cable connectors. Additionally, use only SC/APC fiber connectors throughout the fiber network, including fiber distribution panels. This is critical for ensuring system performance.

4.1.3 LED Indicators

The unit's front panel LEDs indicate fault conditions and commanded or fault lockouts. The LEDs do not indicate warnings or whether the system test has been performed. Only use the LEDs to provide basic information or as a backup when you are not using AdminManager.

Upon power up, the Expansion Hub goes through a five-second test to check the LED lamps. During this time, the LEDs blink through the states shown in Table 4-2, letting you visually verify that the LED lamps and the firmware are functioning properly.

NOTE: Refer to Section 9 for troubleshooting using the LEDs.

Unit Status and DL/UL Status LEDs

The Expansion Hub unit status and DL/UL status LEDs can be in one of the states shown in Table 4-1. These LEDs can be:

- steady green
- steady red

There is no off state when the unit's power is on.

Table 4-1 Expansion Hub Unit Status and DL/UL Status LED States

	LED State	Indicates
POWER ● ● DL STATUS E-HUB STATUS ● ● UL STATUS	Green / Green Green / Green	<ul style="list-style-type: none"> • The Expansion Hub is connected to power and all power supplies are operating. • The Expansion Hub is not reporting a fault or lockout condition; but the system test may need to be performed or a warning condition could exist (use AdminManager to determine this). • Optical power in is above minimum (the Main Hub is connected) although the cable optical loss may be greater than recommended maximum. • Optical power out (uplink laser) is normal and communications with the Main Hub are normal.
POWER ● ● DL STATUS E-HUB STATUS ● ● UL STATUS	Green / Green Red / Green	<ul style="list-style-type: none"> • Optical power in is above minimum (the Main Hub is connected) although the cable optical loss may be greater than recommended maximum. • Optical power out (uplink laser) is normal and communications with the Main Hub are normal. • The Expansion Hub is reporting a fault or commanded lockout.
POWER ● ● DL STATUS E-HUB STATUS ● ● UL STATUS	Green / Red Red / Green	<ul style="list-style-type: none"> • A fault condition was detected, optical power in is below minimum. (the Main Hub is not connected, is not powered, or the Main Hub's downlink laser has failed, or the downlink fiber is disconnected or damaged.)
POWER ● ● DL STATUS E-HUB STATUS ● ● UL STATUS	Green / Green Red / Red	<ul style="list-style-type: none"> • The Expansion Hub is reporting a fault condition. • Optical power in is above minimum (Main Hub is connected) although the cable optical loss may be greater than recommended maximum. • Optical power out is below minimum (Expansion Hub uplink laser has failed; unable to communicate with Main Hub). UL STATUS LED state must be checked within the first 90 seconds after power on. If initially green, then red after 90 seconds, it means that there is no communication with the Main Hub. If red on power up, replace the Expansion Hub.
POWER ● ● DL STATUS E-HUB STATUS ● ● UL STATUS	Green / Red Red / Red	<ul style="list-style-type: none"> • Optical power in is below minimum (the Main Hub is not connected, is not powered, or the Main Hub's downlink laser has failed, or the downlink fiber is disconnected or damaged.) • Optical power out is below minimum (the Expansion Hub uplink laser has failed; is unable to communicate with the Main Hub). UL STATUS LED state must be checked within the first 90 seconds after power on. If initially green, then red after 90 seconds, it means that there is no communication with the Main Hub. If red on power up, the uplink laser has failed, replace the Expansion Hub.

Table 4-1 Expansion Hub Unit Status and DL/UL Status LED States

	LED State	Indicates
POWER ●● DL STATUS E-HUB STATUS ●● UL STATUS	Green / Red Green / Red	• Expansion Hub is in factory test mode, return it to the factory.
POWER ●● DL STATUS E-HUB STATUS ●● UL STATUS	Red/ Red Red/ Red	• One or more power supplies are out of specification. The hub needs to be replaced.

Port LEDs

The Expansion Hub has one pair of port LEDs for each of the eight RJ-45 ports. The port LEDs can be in one of the states shown in Table 4-2. These LEDs can be:

- off
- steady green
- steady red

Table 4-2 Expansion Hub Port LED States

	LED State	Indicates
LINK ○ RAU ○	Off Off	• The RAU is not connected.
LINK ● RAU ●	Green Green	• The RAU is connected. • No faults from the RAU.
LINK ● RAU ○	Red Off	• The RAU was disconnected. • The RAU is not communicating. • The RAU port power is tripped. • 36 VDC is shutdown due to an EH over-temperature condition.
LINK ● RAU ●	Green Red	• The RAU is connected. • The RAU is reporting a fault or lockout condition.

4.2 Expansion Hub Rear Panel

Figure 4-4 Expansion Hub Rear Panel

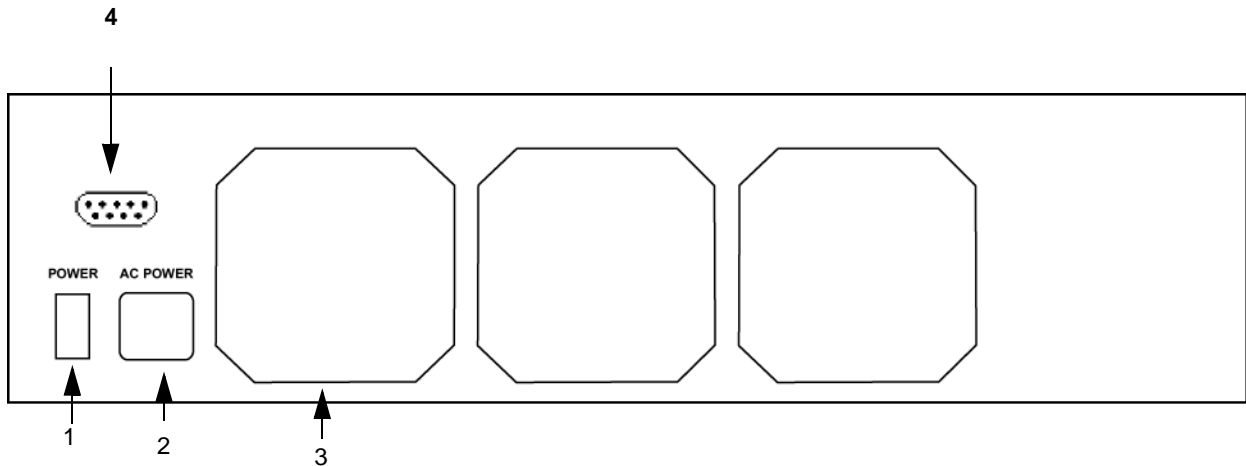

1. Power on/off switch
2. AC power cord connector
3. Three air exhaust vents
4. DB-9 connector (UNS-EH-2 specific)

Table 4-3 DB-9 Pin Connectors

Pin	Connection	Signal Name
1	N/C	N/A
2	+5V through a 10K Ohm resistor. Input to micro controller	ALARM3
3	+5V through a 10K Ohm resistor. Input to micro controller	ALARM1
4	GND	N/A
5	+5V through a 10K Ohm resistor. Input to micro controller)	ALARM2
6	N/C	N/A
7	N/C	N/A
8	GND	N/A
9	GND	N/A

This interface can both generate contact alarms and sense a single external alarm contact.

4.3 Faults, Warnings, and Status Messages

This interface monitors the output contact closures from a Universal Power Supply (UPS). Verify the output contact closure state (normally closed or normally open) of the UPS, and set the appropriate contact definition using AdminManager.

- Faults are service impacting.
- Warnings indicate a possible service impact.
- Status messages are generally not service impacting.

NOTE: You can select what type of events AdminManager displays. Refer to Section 3.4.2, “View Preference,” on page 3-10.

Both fault and warning conditions of the Expansion Hub and attached RAUs are reported to the Main Hub. Only faults are indicated by LEDs.

For more information, refer to:

- page 9-10 for Expansion Hub faults.
- page 9-20 for Expansion Hub warnings.
- page 9-24 for Expansion Hub status messages.
- page 9-30 for troubleshooting Expansion Hub LEDs.

4.4 Expansion Hub Specifications

Table 4-4 Expansion Hub Specifications

Specification	Description
Enclosure Dimensions (H × W × D)	89 mm × 438 mm × 305 mm (3.5 in. × 17.25 in. × 12 in.) 2U
Weight	< 5 kg (< 11 lb)
Operating Temperature ^c	0° to +45°C (+32° to +113°F)
Non-operating Temperature ^c	−20° to +85°C (−4° to +185°F)
Operating Humidity, non-condensing	5% to 95%
Cat-5/5E/6 Connectors ^a	8 shielded RJ-45, female (Cat-5/6)
Fiber Connectors ^b	1 Pair, SC/APC
LED Alarm and Status Indicators	Unit Status (1 pair): <ul style="list-style-type: none"> • Power • E-Hub Status Fiber Link Status (1 pair): <ul style="list-style-type: none"> • DL Status • UL Status RAU/Link Status (1 pair per RJ-45 port): <ul style="list-style-type: none"> • Link • RAU
AC Power (Volts) (47–63 Hz)	Rating: 115/230V, 5/2.5A, 50–60 Hz Operating Range: 90–132V/170–250V auto-ranging, 2.2–1.5A/1.2–0.8A, 47–63 Hz
Power Consumption (W)	4 RAUs: 120 typical/148 max 4 RAUs & 4 Extenders: 137 typical/172 max 8 RAUs: 170 typical/212 max 8 RAUs & 8 Extenders: 204 typical/260 max
MTBF	92,820 hours

- It is important that you use only Cat-5/5E/6 ScTP cable with shielded RJ-45 connectors.
- It is critical to system performance that only SC/APC fiber connectors are used throughout the fiber network, including fiber distribution panels.
- For Japan, see separate addendum - *Japan Specification Document*.

Unison Remote Access Unit

The Remote Access Unit (RAU) is an active transceiver that connects to an Expansion Hub using industry-standard Cat-5/5E/6 screened twisted pair (ScTP) cable, which delivers RF signals, configuration information, and electrical power to the RAU.

An RAU passes RF signals between an Expansion Hub and an attached passive antenna where the signals are transmitted to wireless devices.

Figure 5-1 Remote Access Unit in a Unison System

Downlink Path: The RAU receives downlink IF signals from an Expansion Hub via Cat-5/5E/6 cable. It converts the signals to RF and sends them to a passive RF antenna via coaxial cable.

Also, the RAU receives configuration information from the Main Hub via the Cat-5/5E/6 cable.



Uplink Path: The RAU receives uplink RF signals from a passive RF antenna via coaxial cable. It converts the signals to IF and sends them to an Expansion Hub via Cat-5/5E/6 cable.

Also, the RAU sends its status information to the Expansion Hub via the Cat-5/5E/6 cable.

Figure 5-2 Remote Access Unit Block Diagram

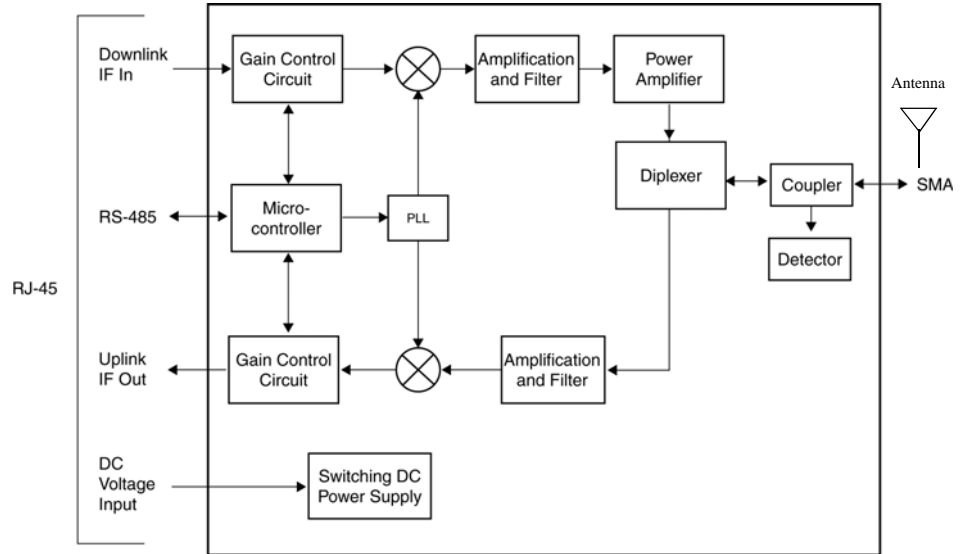

The Unison RAUs are manufactured to a specific band or set of bands. Table 5-1 lists the Unison RAUs, the Unison Band, and the frequency band(s) they cover.

Table 5-1 Frequency Bands covered by Unison RAUs

Unison RAU	Part Number	Unison Band	RF Passband	
			Downlink (MHz)	Uplink (MHz)
Cellular	UNS-CELL-1	Cellular	869–894	824–849
DCS	UNS-DCS-1	DCS1	1805–1842.5	1710–1747.5
		DCS2	1842.5–1880	1747.5–1785
		DCS4	1815–1850	1720–1755
GSM	UNS-GSM-1	GSM	925–960	880–915
iDEN	UNS-IDEN-1	iDEN	851–869	806–824
PCS	UNS-PCS-2	PCS A,D,B	1930–1965	1850–1885
		PCS D,B,E,F	1945–1975	1865–1895
		PCS E,F,C	1965–1990	1885–1910
		PCS A4/A5/D/B/E	1935-1970	1655-1890
		PCS A5/D/B/E/F	1940-1975	1860-1895
		PCS D/B/E/F/C2	1945-1982.5	1865-1902.5
		PCS B4/B5/E/F/C	1955-1990	1875-1910
UMTS	UNS-UMTS-2	UMTS 1	2110–2145	1920–1955
		UMTS 2	2125–2160	1935–1970
		UMTS 3	2135–2170	1945–1980
	UNS-J1-UMTS **	UMTS 1-Japan	2110–2130	1920–1940
		UMTS 2-Japan	2130–2150	1940–1960
		UMTS 3-Japan	2150–2170	1960–1980
AWS	UNS-AWS-1	AWS1	2110-2145	1710-1745
		AWS2	2120-2155	1720-1755
PS 700	UNS-PS70-1	PS700	763-776	793-806
700 LTE	UNS-CS75-1	700 UC	746-757	776-787

** For Japan, see separate addendum - *Japan's Specification Document*.

5.1 Remote Access Unit Connectors

5.1.1 SMA Connector

The RAU has one female SMA connector. The connector is a duplexed RF input/output port that connects to a standard passive antenna using coaxial cable.

5.1.2 RJ-45 Connector

The RAU has one RJ-45 connector that connects it to an Expansion Hub using Cat-5/5E/6 ScTP cable. Use shielded RJ-45 connectors on the Cat-5/5E/6 cable.

NOTE: For system performance, use only Cat-5/5E/6 ScTP cable with shielded RJ-45 connectors.

5.2 LED Indicators

Upon power up, the RAU goes through a two-second test to check the LED lamps. During this time, the LEDs blink green/green red/red. This lets you visually verify that the LED lamps and the firmware are functioning properly.

NOTE: Refer to Section 9 for troubleshooting using the LEDs.

Status LEDs

The RAU status LEDs can be in one of the states shown in Table 5-2. These LEDs can be:

- off
- steady green
- steady red

There is no off state when the unit's power is on.

Table 5-2 Remote Access Unit LED States

	LED State	Indicates
LINK ○ ALARM ○	Off Off	<ul style="list-style-type: none"> The RAU is not receiving DC power.
LINK ● ALARM ●	Green Green	<ul style="list-style-type: none"> The RAU is powered and is not indicating a fault condition. Communication with the Expansion Hub is normal; but the system test may need to be performed or a warning condition could exist (use AdminManager to determine).
LINK ● ALARM ●	Green Red	<ul style="list-style-type: none"> The RAU is indicating a fault or lockout condition, but communication with the Expansion Hub is normal.
LINK ● ALARM ●	Red Red	<ul style="list-style-type: none"> The RAU is reporting a fault or lockout condition, and it is not able to communicate with the Expansion Hub.

5.3 Faults, Warnings, and Status Messages

An event is classified as a fault, warning, or status message.

- Faults are service impacting.
- Warnings indicate a possible service impact.
- Status messages are generally not service impacting.

NOTE: You can select the type of events AdminManager displays. Refer to Section 3.4.2, “View Preference,” on page 3-10.

Both fault and warning conditions are reported to the Expansion Hub where they are stored until the Main Hub queries the system status. Only faults are indicated by LEDs.

For more information, refer to:

- page 9-15 for RAU faults.
- page 9-21 for RAU warnings.
- page 9-26 for RAU status messages.

5.4 Remote Access Unit Specifications

Table 5-3 Remote Access Unit Specifications

Specification**	Description
Dimensions (H × W × D)	44 mm × 305 mm × 158 mm (1.7 in. × 12 in. × 6.2 in.)
Weight	< 1 kg (< 2 lb)
Operating Temperature**	–25° to +45°C (–13° to +113°F)
Non-operating Temperature**	–25° to +85°C (–13° to +185°F)
Operating Humidity, non-condensing	5% to 95%
RF Connectors	1 shielded RJ-45, female (Cat-5/6) ^a 1 SMA, male (coaxial)
LED Alarm and Status Indicators	Unit Status (1 pair): • Link • Alarm
Maximum Heat Dissipation (W)	12.5 typical, 16 max (from Expansion Hub)
MTBF	282,207 hours

a. For system performance, it is important that you use only Cat-5/5E/6 ScTP cable with shielded RJ-45 connectors.

** For Japan, see separate addendum - *Japan Specification Document*.

5.5 RAUs in a Dual Band System

A Dual Band Diplexer can be used to connect two RAUs, one that is below 1 GHz and one that is above 1 GHz, for output to a single passive antenna.

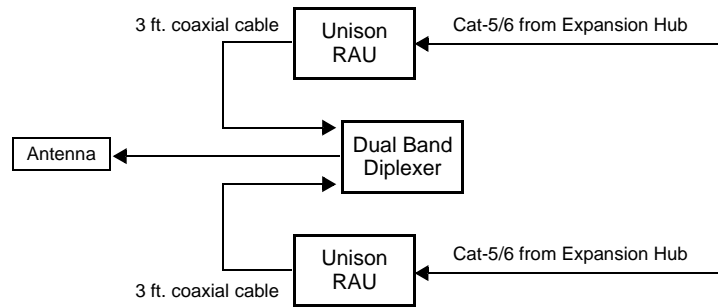

Refer to the Dual Band Diplexer specifications (ADC PN: 8000-54) for technical information.

An alternative to a diplexer is use dual-port, dual-band antennas shown in Table 5-3.

Figure 5-3 Dual-Port Antenna Configuration

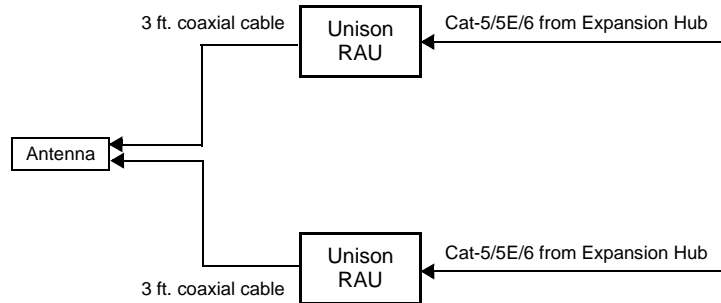

Designing a Unison Solution

Designing a Unison solution is a matter of determining coverage and capacity needs. This requires the following steps:

1. Determine the wireless service provider's requirements.

This information is usually determined by the service provider:

- Frequency (that is, 850 MHz)
- Band (that is, "A" band in the Cellular spectrum)
- Protocol (that is, TDMA, CDMA, GSM, iDEN)
- Peak capacity requirement (this, and whether or not the building is split into sectors, determines the number of carriers that the system will have to transmit)
- Design goal (RSSI, received signal strength at the wireless handset, that is, -85 dBm)

The design goal is always a stronger signal than the cell phone needs. It includes inherent factors which affect performance (refer to Section 6.4.1 on page 6-26).

- RF source (base station or BDA), type of equipment if possible

2. Determine the power per carrier and input power from the base station or BDA into the Main Hub: refer to Section 6.1, "Maximum Output Power Per Carrier at RAU," on page 6-3.

The maximum power per carrier is a function of the number of RF carriers, the carrier headroom requirement, signal quality issues, regulatory emissions requirements, and Unison's RF performance. Typically, the power per carrier decreases as the number of carriers increases.

3. Determine the in-building environment: refer to Section 6.2, "Estimating RF Coverage," on page 6-13.

- Determine which areas of the building require coverage (entire building, public areas, parking levels, and so on.)
- Obtain floor plans to determine floor space of building and the wall layout of the proposed areas to be covered. Floor plans are also useful when selecting antenna locations.

-
- If possible, determine the building's construction materials (sheetrock, metal, concrete, and so on.)
 - Determine type of environment
 - Open layout (for example, a convention center)
 - Dense, close walls (for example, a hospital)
 - Mixed use (for example, an office building with hard wall offices and cubicles)

4. Develop an RF link budget: refer to Section 6.4, “Link Budget Analysis,” on page 6-26.

Knowing the power per carrier, you can calculate an RF link budget. This is used to predict how much propagation loss can be allowed in the system, while still providing satisfactory performance throughout the area being covered. The link budget is a methodical way to derive a “design goal”. If the design goal is provided in advance, the link budget is: *allowable RF loss = maximum power per carrier – design goal*.

5. Determine the appropriate estimated path loss slope that corresponds to the type of building and its layout, and estimate the coverage distance for each RAU: refer to Section 6.2, “Estimating RF Coverage,” on page 6-13.

The path loss slope (PLS), which gives a value to the RF propagation characteristics within the building, is used to convert the RF link budget into an estimate of the coverage distance per antenna. This helps establish the Unison equipment quantities needed. The actual path loss slope that corresponds to the specific RF environment inside the building can also be determined empirically by performing an RF site-survey of the building. This involves transmitting a calibrated tone for a fixed antenna and making measurements with a mobile antenna throughout the area surrounding the transmitter.

6. Determine the items required to connect to the base station: refer to Section 6.6, “Connecting a Main Hub to a Base Station,” on page 6-39.

Once you know the quantities of Unison equipment you will use, you can determine the accessories (combiners/dividers, surge suppressors, repeaters, attenuators, circulators, and so on.) required to connect the system to the base station.

The individual elements that must be considered in designing a Unison solution are explained in the following sections.

NOTE: Access the ADC customer portal at adc.com for on-line dimensioning and design tools.

6.1 Maximum Output Power Per Carrier at RAU

The following tables show the recommended maximum power per carrier out of the RAU SMA connector for different frequencies, formats, and numbers of carriers. These limits are dictated by RF signal quality and regulatory emissions issues. The maximum input power to the Main Hub is determined by subtracting the system gain from the maximum output power of the RAU. System gain is software selectable from 0 dB to 15 dB in 1 dB steps. Additionally, both the uplink and downlink of each RAU gain can be reduced by 10 dB.

When you connect a Main Hub to a base station or repeater, the RF power per carrier usually needs to be attenuated in order to avoid exceeding Unison's maximum output power recommendations.

Refer to Section 6.7, "Designing for a Neutral Host System," on page 6-46 when combining frequencies or protocols on a single Main Hub.



WARNING: Exceeding the maximum input power could cause permanent damage to the Main Hub. Do not exceed the maximum composite input power of 1W (+30 dBm) to the Main Hub at any time.

NOTE: These specifications are for downlink power at the RAU output (excluding antenna).

6.1.1 700 MHz LTE

Table 6-1 700 MHz Power per Carrier

No. of Carriers	Power per Carrier (dBm)
	LTE
1	15.0
2	11.0
3	8.0
4	6.5
5	5.0

These PPC numbers assume 2 km of SMF or 1 km of MMF.
Note: Operation at or above these output power levels may prevent Unison from meeting RF performance specifications or FCC Part 15 and EN55022 emissions requirements. Refer to the Unison Installation, Operation, and Reference manual for system design information.

6.1.2 800 MHz Cellular

Table 6-2 Cellular Power per Carrier

No. of Carriers	Power per Carrier (dBm)						CDMA 2 km SMF/ 1 km MMF
	AMPS 2 km SMF/ 1 km MMF	TDMA 2 km SMF/ 1 km MMF	GSM 2 km SMF	GSM 1 km MMF	EDGE 2 km SMF	EDGE 1 km MMF	
1	27.0	24.0	27.0	27.0	24.0	24.0	17.0
2	21.0	19.0	14.5	12.5	14.5	12.5	14.0
3	17.5	16.0	12.5	10.5	12.5	10.5	12.0
4	14.5	14.0	11.5	9.5	11.5	9.5	11.0
5	13.0	12.5	10.5	8.5	10.5	8.5	10.0
6	11.5	11.5	9.5	7.5	9.5	7.5	9.0
7	10.5	10.5	9.0	7.0	9.0	7.0	8.5
8	9.5	9.5	8.5	6.5	8.5	6.5	8.0
9	9.0	9.0	8.5	6.5	8.5	6.5	
10	8.0	8.5	8.0	6.0	8.0	6.0	
11	8.0	8.0	7.5	5.5	7.5	5.5	
12	7.5	7.5	7.5	5.5	7.0	5.5	
13	7.0	7.5	7.0	5.0	7.0	5.0	
14	6.5	7.0	7.0	5.0	6.5	5.0	
15	6.5	6.5	6.5	4.5	6.0	4.5	
16	6.0	6.5	6.5	4.5	6.0	4.5	
20	5.0	5.5	5.5	3.5	5.0	3.5	
30	3.0	3.5	4.0	2.0	3.0	2.5	

Note: Operation at or above these output power levels may prevent Unison from meeting RF performance specifications or FCC Part 15 and EN55022 emissions requirements. Refer to the Unison Installation, Operation, and Reference manual for system design information.

6.1.3 800 MHz iDEN/SMR

Table 6-3 iDEN/SMR Power per Carrier

No. of Carriers	Power per Carrier (dBm)				Motient Data TAC 2 km SMF/ 1 km MMF
	iDEN 2 km SMF/ 1 km MMF	Analog FM 2 km SMF/ 1 km MMF	CQPSK 2 km SMF/ 1 km MMF	C4FM 2 km SMF/ 1 km MMF	
1	10.0	10.0	10.0	10.0	10.0
2	10.0	10.0	10.0	10.0	10.0
3	10.0	10.0	10.0	10.0	10.0
4	10.0	10.0	10.0	10.0	10.0
5	9.0	10.0	10.0	10.0	
6	8.0	10.0	9.5	10.0	
7	7.0	9.5	9.0	9.0	
8	6.5	8.5	8.0	8.5	
9	6.0	8.0	7.5	7.5	
10	5.5	7.0	7.0	7.0	

Note: Operation at or above these output power levels may prevent Unison from meeting RF performance specifications or FCC Part 15 and EN55022 emissions requirements. Refer to the Unison Installation, Operation, and Reference manual for system design information.

6.1.4 900 MHz GSM and EDGE

Table 6-4 GSM and EDGE Power per Carrier

No. of Carriers	Power per Carrier (dBm)			
	GSM 2 km SMF	GSM 1 km MMF	EDGE 2 km SMF	EDGE 1 km MMF
1	16.0	16.0	16.0	16.0
2	13.0	12.0	13.0	12.0
3	11.0	10.0	11.0	10.0
4	10.0	9.0	10.0	9.0
5	9.0	8.0	9.0	8.0
6	8.0	7.0	8.0	7.0
7	7.5	6.5	7.5	6.5
8	7.0	6.0	7.0	6.0
9	6.5	5.5	6.5	5.5
10	6.0	5.5	6.0	5.5
11	5.5	5.0	5.5	5.0
12	5.0	4.5	5.0	4.5
13	5.0	4.5	5.0	4.5
14	4.5	4.0	4.5	4.0
15	4.0	4.0	4.0	4.0
16	4.0	3.5	4.0	3.5

Note: Operation at or above these output power levels may prevent Unison from meeting RF performance specifications or FCC Part 15 and EN55022 emissions requirements. Refer to the Unison Installation, Operation, and Reference manual for system design information.

6.1.5 1800 MHz DCS

Table 6-5 DCS Power per Carrier

No. of Carriers	Power per Carrier (dBm)				
	GSM 2 km SMF	GSM 1 km MMF	EDGE 2 km SMF	EDGE 1 km MMF	CDMA 2 km SMF/1 km MMF
1	17.5	17.5	17.5	17.5	16.0
2	14.5	14.0	14.5	14.0	13.0
3	12.5	12.0	12.5	12.0	11.0
4	11.5	11.0	11.5	11.0	10.0
5	10.5	10.0	10.5	10.0	9.0
6	9.5	9.0	9.5	9.0	8.0
7	9.0	8.5	9.0	8.5	7.5
8	8.5	8.0	8.0	8.0	7.0
9	8.0	7.5	7.5	7.5	6.5
10	7.5	7.5	7.0	7.0	6.0
11	7.0	7.0	6.5	6.5	5.5
12	6.5	6.5	6.0	6.0	5.0
13	6.5	6.5	6.0	6.0	5.0
14	6.0	6.0	5.5	5.5	4.5
15	5.5	5.5	5.0	5.0	4.0
16	5.5	5.5	5.0	5.0	4.0

Note: Operation at or above these output power levels may prevent Unison from meeting RF performance specifications or FCC Part 15 and EN55022 emissions requirements. Refer to the Unison Installation, Operation, and Reference manual for system design information.

6.1.6 1900 MHz PCS

Table 6-6 PCS Power per Carrier

No. of Carriers	Power per Carrier (dBm)					CDMA 2 km SMF/1 km MMF
	TDMA 2 km SMF/1 km MMF	GSM 2 km SMF	GSM 1 km MMF	EDGE 2 km SMF	EDGE 1 km MMF	
1	23.0	26.0	26.0	23.0	23.0	16.0
2	18.0	15.5	14.0	15.5	14.0	13.0
3	15.0	13.5	12.0	13.5	12.0	11.0
4	13.0	12.0	11.0	12.0	11.0	10.0
5	11.5	11.0	10.0	10.5	10.0	9.0
6	10.5	10.5	9.0	9.5	9.0	8.0
7	9.5	10.0	8.5	9.0	8.5	7.5
8	8.5	9.0	8.0	8.0	8.0	7.0
9	8.0	8.5	7.5	7.5	7.5	
10	7.5	8.0	7.5	7.0	7.0	
11	7.0	7.5	7.0	6.5	6.5	
12	6.5	7.0	6.5	6.0	6.0	
13	6.5	6.5	6.5	6.0	6.0	
14	6.0	6.5	6.0	5.5	5.5	
15	5.5	6.0	6.0	5.0	5.0	
16	5.5	5.5	5.5	5.0	5.0	
20	4.5	4.5	4.5	4.0	4.0	
30	2.5	3.0	3.0	2.0	2.0	

Note: Operation at or above these output power levels may prevent Unison from meeting RF performance specifications or FCC Part 15 and EN55022 emissions requirements. Refer to the Unison Installation, Operation, and Reference manual for system design information.

6.1.7 2.1 GHz UMTS

Table 6-7 UMTS Power per Carrier**

No. of Carriers	Power per Carrier (dBm)
	WCDMA 2 km SMF/1 km MMF
1	15.0
2	11.0
3	8.0
4	6.5
5	5.0
6	4.0
7	3.0

These PPC numbers assume 2 km of SMF or 1 km of MMF.

Note: measurements taken with no baseband clipping.

Note: Operation at or above these output power levels may prevent Unison from meeting RF performance specifications or FCC Part 15 and EN55022 emissions requirements. Refer to the Unison Installation, Operation, and Reference manual for system design information.

** For Japan, refer to separate addendum - *Japan Specification Document*.

6.1.8 1.7/2.1 GHz AWS

Table 6-8 AWS Power per Carrier

No. of Carriers	Power per Carrier (dBm)
	WCDMA 2 km SMF/1 km MMF
1	15.0
2	11.0
3	8.0
4	6.5
5	5.0
6	4.0
7	3.0

These PPC numbers assume 2 km of SMF or 1 km of MMF.

Note: measurements taken with no baseband clipping.

Note: Operation at or above these output power levels may prevent Unison from meeting RF performance specifications or FCC Part 15 and EN55022 emissions requirements. Refer to the Unison Installation, Operation, and Reference manual for system design information.

6.1.9 700 MHz Public Safety

Table 6-9 Public Safety 700 MHz Power per Carrier

No. of Carriers	Power per Carrier (dBm)				
	iDEN	APCO25 CQPSK	APCO25 C4FM	CDMA 2000	WCDMA
1	10.0	10.0	10.0	16.0	15.0
2	10.0	10.0	10.0	13.0	11.0
3	10.0	10.0	10.0	11.0	8.0
4	10.0	10.0	10.0	10.0	6.5
5	9.0	10.0	10.0	9.0	5.0
6	8.0	9.5	10.0	8.0	
7	7.0	9.0	9.0	7.5	
8	6.5	8.0	8.5	7.0	
9	6.0	7.5	7.5		
10	5.5	7.0	7.0		

Note: Operation at or above these output power levels may prevent Unison from meeting RF performance specifications or FCC Part 15 and EN55022 emissions requirements. Refer to the Unison Installation, Operation, and Reference manual for system design information.

Table 6-10 900 MHz Paging/SMR/iDEN

No. of Carriers	Power per Carrier (dBm)					
	iDEN 2 km SMF 1 km MMF	Analog FM 2 km SMF 1 km MMF	CQPSK 2 km SMF 1 km MMF	C4FM 2 km SMF 1 km MMF	Mobitex 2 km SMF 1 km MMF	POCSAG/ REFLEX 2 km SMF 1 km MMF
1	17.5	26.0	22.0	26.0	26.0	26.0
2	14.0	19.5	17.0	19.5	19.5	19.5
3	11.5	16.5	14.5	16.0	16.0	16.0
4	10.0	13.5	12.5	13.5	13.5	13.5
5	9.0	12.0	11.0	11.5		
6	8.0	10.5	9.5	10.0		
7	7.0	9.5	9.0	9.0		
8	6.5	8.5	8.0	8.5		
9	6.0	8.0	7.5	7.5		
10	5.5	7.0	7.0	7.0		

Note: Operation at or above the output power levels may prevent Unison from meeting RF performance specifications or FCC Part 15 and EN55022 emissions requirements. Refer to the Unison Installation, Operation, and Reference manual for system design information.

Maximum Output Power Per Carrier at RAU

Table 6-11 800 MHz Cellular/1900 MHz PCS Power per Carrier

No. of Carriers	Recommended Maximum Output Power per Carrier at RAU (dBm)									
	800 MHz Cellular			1900 MHz PCS						
	TDMA	AMPS	CDMA	TDMA	GSM		EDGE		CDMA	
	2 km SMF/ 1 km MMF	2 km SMF/ 1 km MMF	2 km SMF/ 1 km MMF	2 km SMF	2 km SMF	1 km MMF	2 km SMF	1 km MMF	2 km SMF/ 1 km MMF	
1	23.0	26.0	16.0	21.5	24.5	24.5	21.5	21.5	14.5	
2	18.0	20.0	13.0	16.5	14.0	12.5	14.0	12.5	11.5	
3	15.0	16.5	11.0	13.5	12.0	10.5	12.0	10.5	9.5	
4	13.0	13.5	10.0	11.5	10.5	9.5	10.5	9.5	8.5	
5	11.5	12.0	9.0	10.0	9.5	8.5	9.0	8.5	7.5	
6	10.5	10.5	8.0	9.0	9.0	7.5	8.0	7.5	6.5	
7	9.5	9.5	7.5	8.0	8.5	7.0	7.5	7.0	6.0	
8	8.5	8.5	7.0	7.0	7.5	6.5	6.5	6.5	5.5	
9	8.0	8.0	N/A	6.5	7.0	6.0	6.0	6.0		
10	7.5	7.0		6.0	6.5	6.0	5.5	5.5		
11	7.0	7.0		5.5	6.0	5.5	5.0	5.0		
12	6.5	6.5		5.0	5.5	5.0	4.5	4.5		
13	6.5	6.0		5.0	5.0	5.0	4.5	4.5		
14	6.0	5.5		4.5	5.0	4.5	4.0	4.0		
15	5.5	5.5		4.0	4.5	4.5	3.5	3.5		
16	5.5	5.0		4.0	4.0	4.0	3.5	3.5		
20	4.5	4.0			3.0					

Note: Operation at or above these output power levels may prevent Unison from meeting RF performance specifications or FCC Part 15 and EN55022 emissions requirements. Refer to the Unison Installation, Operation, and Reference manual for system design information.

Allowing for Future Capacity Growth

Sometimes a Unison deployment is initially used to enhance coverage. Later, that same system may also need to provide increased capacity. Thus, the initial deployment might only transmit two carriers but need to transmit four carriers later. There are two options for dealing with this scenario:

1. Design the initial coverage with a maximum power per carrier for four carriers.
2. Design the initial coverage for two carriers but leave RAU ports on the Expansion Hubs unused. These ports can be used later if coverage holes are discovered once the power per carrier is lowered to accommodate the two additional carriers.

6.2 Estimating RF Coverage

The maximum power per carrier (based on the number and type of RF carriers that are being transmitted) and the minimum acceptable received power at the wireless device (i.e., RSSI, the design goal) establish the RF link budget, and consequently the maximum acceptable path loss between the antenna and the wireless device.

Figure 6-1 Determining Path Loss between the Antenna and the Wireless Device

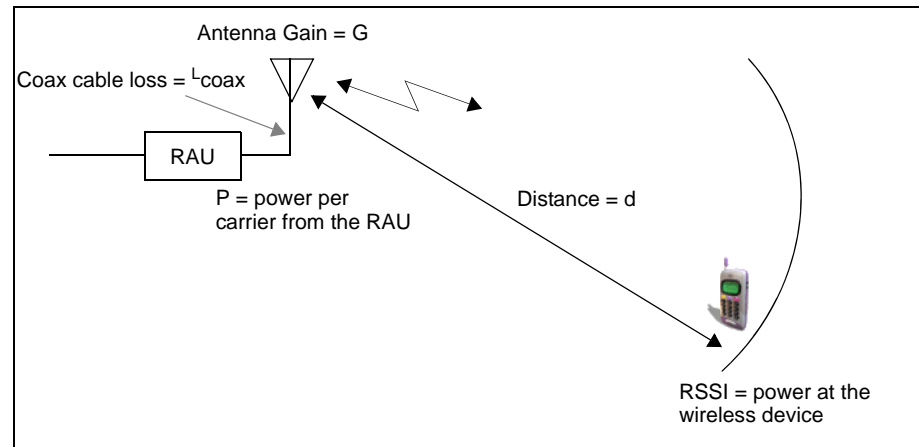

$$(P - L_{\text{coax}} + G) - \text{RSSI} = \text{PL} \quad (1)$$

The path loss (PL) is the loss in decibels (dB) between the antenna and the wireless device. The distance, d , from the antenna corresponding to this path loss can be calculated using the path loss equations in Section 6.2.1 and in Section 6.2.2.

Coaxial cable is used to connect the RAU to an antenna. The following table lists coaxial cable loss for various cable lengths.

Table 6-12 Coaxial Cable Losses (L_{coax})

Length of Cable (.195 in. diameter)	Loss at 800 MHz (dB)	Loss at 1900 MHz (dB)
0.9 m (3 ft)	0.6	0.8
1.8 m (6 ft)	1.0	1.5
3.0 m (10 ft)	1.5	2.3

6.2.1 Path Loss Equation

Indoor path loss obeys the distance power law¹ in equation (2):

$$PL = 20\log(4\pi d_0 f/c) + PLS\log(d/d_0) + X_s \quad (2)$$

where:

- PL is the path loss at a distance, d, from the antenna (the distance between the antenna connected to the RAU and the point where the RF signal decreases to the minimum acceptable level at the wireless device).
- d is the distance expressed in meters.
- d₀ is usually taken as 1 meter of free-space.
- f is the operating frequency in Hertz.
- c is the speed of light in a vacuum (3.0 × 10⁸ m/sec).
- PLS is the path loss slope and depends on the building “clutter” or environment.
- X_s is a normal random variable that depends on partition losses inside the building, and therefore, depends on the frequency of operation.

As a reference, the following table gives estimates of signal loss for some RF barriers.¹

Table 6-13 Average Signal Loss of Common Building Materials

Partition Type	Loss (dB)	Frequency (MHz)
Metal wall	26	815
Aluminum siding	20	815
Foil insulation	4	815
Cubicle walls	1.4	900
Concrete block wall	13	1300
Concrete floor	10	1300
Sheetrock	1 to 2	1300
Light machinery	3	1300
General machinery	7	1300
Heavy machinery	11	1300
Equipment racks	7	1300
Assembly line	6	1300
Ceiling duct	5	1300
Metal stairs	5	1300

1. Rappaport, Theodore S. *Wireless Communications, Principles, and Practice*. Prentice Hall PTR, 1996.

6.2.2 Coverage Distance

Use equations (1) and (2), on pages 6-13 and 6-14, respectively, to estimate the distance from the antenna to where the RF signal decreases to the minimum acceptable level at the wireless device.

Equation (2) can be simplified to:

$$PL(d) = 20\log(4\pi f/c) + PLS\log(d) \tag{3}$$

where PLS (path loss slope) is chosen to account for the building’s environment. Because different frequencies penetrate partitions with different losses, the value of PLS varies depending on the frequency.

Table 6-14 shows the estimated path loss slope (PLS) for various environments that have different “clutter” (that is, objects that attenuate the RF signals, such as walls, partitions, stairwells, equipment racks, and so on.)

Table 6-14 Estimated Path Loss Slope for Different In-Building Environments

Environment Type	Example	PLS for 800/900 MHz	PLS for 1800 /1900/2100 MHz
Open Environment with very few RF obstructions	Parking Garage, Convention Center	33.7	30.1
Moderately Open Environment with low-to-medium amount of RF obstructions	Warehouse, Airport, Manufacturing	35	32
Mildly Dense Environment with medium-to-high amount of RF obstructions	Retail, Office Space with approximately 80% cubicles and 20% hard walled offices	36.1	33.1
Moderately Dense Environment with medium-to-high amount of RF obstructions	Office Space with approximately 50% cubicles and 50% hard walled offices	37.6	34.8
Dense Environment with large amount of RF obstructions	Hospital, Office Space with approximately 20% cubicles and 80% hard walled offices	39.4	38.1

For simplicity, Equation (3), Coverage Distance, can be used to estimate the coverage distance of an antenna connected to an RAU, for a given path loss, frequency, and type of in-building environment.

Table 6-15 gives the value of the first term of Equation (3) (that is, $(20\log(4\pi f/c))$) for various frequency bands.

Table 6-15 Frequency Bands and the Value of the first Term in Equation (3)

	Band (MHz)		Mid-Band Frequency (MHz)	$20\log(4\pi f/c)$
	Uplink	Downlink		
800 MHz Cellular	824–849	869–894	859	31.1
800 MHz iDEN	806–824	851–869	837.5	30.9
900 MHz GSM	890–915	935–960	925	31.8
900 MHz EGSM	880–915	925–960	920	31.7
1800 MHz DCS	1710–1785	1805–1880	1795	37.5
1900 MHz PCS	1850–1910	1930–1990	1920	38.1
2.1 GHz UMTS	1920–1980	2110–2170	2045	38.7
1.7/2.1 GHz AWS	1710-1755	2110-2155	2132.5 ^a	39.0
700 MHz PS	793-806	763-776	784.5	30.3
700 MHz LTE	776-787	746-757	766.5	30.1

a. Due to the wide frequency spread between the Uplink and Downlink bands, the mid-band frequency of the Downlink band was chosen for 1.7/2.1 GHz AWS.

For reference, Tables 6-17 through 6-23 show the distance covered by an antenna for various in-building environments. The following assumptions were made:

- Path loss Equation (3)
- 6 dBm output per carrier at the RAU output
- 3 dBi antenna gain
- RSSI = –85 dBm (typical for narrowband protocols, but not for spread-spectrum protocols)

Table 6-16 Approximate Radiated Distance from Antenna for 700 MHz LTE Applications

Facility	Distance from Antenna	
	Meters	Feet
Open Environment	79	258
Moderately Open Environment	67	219
Mildly Dense Environment	59	193
Moderately Dense Environment	50	164
Dense Environment	42	137

Table 6-17 Approximate Radiated Distance from Antenna for 800 MHz Cellular Applications

Environment Type	Distance from Antenna	
	Meters	Feet
Open Environment	73	241
Moderately Open Environment	63	205
Mildly Dense Environment	55	181
Moderately Dense Environment	47	154
Dense Environment	39	129

Table 6-18 Approximate Radiated Distance from Antenna for 800 MHz iDEN Applications

Facility	Distance from Antenna	
	Meters	Feet
Open Environment	75	244
Moderately Open Environment	64	208
Mildly Dense Environment	56	184
Moderately Dense Environment	48	156
Dense Environment	40	131

Table 6-19 Approximate Radiated Distance from Antenna for 900 MHz GSM Applications

Facility	Distance from Antenna	
	Meters	Feet
Open Environment	70	230
Moderately Open Environment	60	197
Mildly Dense Environment	53	174
Moderately Dense Environment	45	148
Dense Environment	38	125

Table 6-20 Approximate Radiated Distance from Antenna for 900 MHz EGSM Applications

Facility	Distance from Antenna	
	Meters	Feet
Open Environment	70	231
Moderately Open Environment	60	197

**Table 6-20 Approximate Radiated Distance from Antenna
for 900 MHz EGSM Applications**

Facility	Distance from Antenna	
	Meters	Feet
Mildly Dense Environment	53	174
Moderately Dense Environment	45	149
Dense Environment	38	125

Table 6-21 Approximate Radiated Distance from Antenna for 1800 MHz DCS Applications

Facility	Distance from Antenna	
	Meters	Feet
Open Environment	75	246
Moderately Open Environment	58	191
Mildly Dense Environment	50	166
Moderately Dense Environment	42	137
Dense Environment	30	100

Table 6-22 Approximate Radiated Distance from Antenna for 1800 MHz CDMA (Korea) Applications

Facility	Distance from Antenna	
	Meters	Feet
Open Environment	75	247
Moderately Open Environment	58	191
Mildly Dense Environment	51	167
Moderately Dense Environment	42	138
Dense Environment	30	100

Table 6-23 Approximate Radiated Distance from Antenna for 1900 MHz PCS Applications

Facility	Distance from Antenna	
	Meters	Feet
Open Environment	72	236
Moderately Open Environment	56	183
Mildly Dense Environment	49	160
Moderately Dense Environment	40	132
Dense Environment	29	96

Table 6-24 Approximate Radiated Distance from Antenna for 2.1 GHz UMTS Applications^a

Facility	Distance from Antenna	
	Meters	Feet
Open Environment	69	226
Moderately Open Environment	54	176

Table 6-24 Approximate Radiated Distance from Antenna for 2.1 GHz UMTS Applications^a

Facility	Distance from Antenna	
	Meters	Feet
Mildly Dense Environment	47	154
Moderately Dense Environment	39	128
Dense Environment	28	93

a. For Japan, refer to the separate addendum: *Japan Specification Document*.

Table 6-25 Approximate Radiated Distance from Antenna for 1.7/2.1 GHz AWS Applications

Facility	Distance from Antenna	
	Meters	Feet
Open Environment	67	220
Moderately Open Environment	52	172
Mildly Dense Environment	46	150
Moderately Dense Environment	38	125
Dense Environment	28	91

Table 6-26 Approximate Radiated Distance from Antenna for 700 MHz Public Safety Applications

Facility	Distance from Antenna	
	Meters	Feet
Open Environment	78	254
Moderately Open Environment	66	216
Mildly Dense Environment	58	190
Moderately Dense Environment	49	162
Dense Environment	41	136

6.2.3 Examples of Design Estimates

Example Design Estimate for an 800 MHz TDMA Application

1. Design goals:

- Cellular (859 MHz = average of the lowest uplink and the highest downlink frequency in 800 MHz Cellular band)
- TDMA provider
- 12 TDMA carriers in the system
- -85 dBm design goal (to 95% of the building) — the minimum received power at the wireless device
- Base station with simplex RF connections

2. **Power Per Carrier:** The tables in Section 6.1, “Maximum Output Power Per Carrier at RAU,” on page 6-3 provide maximum power per carrier information. The 800 MHz TDMA table (on page 6-5) indicates that Unison can support 12 carriers with a recommended maximum power per carrier of 7.5 dBm. The input power should be set to the desired output power minus the system gain.

3. Building information:

- Eight floor building with 9,290 sq. meters (100,000 sq. ft.) per floor; total 74,322 sq. meters (800,000 sq. ft.).
- Walls are sheetrock construction, suspended ceiling tiles.
- Antennas used will be omni-directional, ceiling mounted.
- Standard office environment, 50% hard wall offices and 50% cubicles.

4. **Link Budget:** In this example, a design goal of -85 dBm is used. Suppose 3 dBi omni-directional antennas are used in the design. Then, the maximum RF propagation loss should be no more than 95.5 dB (7.5 dBm + 3 dBi + 85 dBm) over 95% of the area being covered. *It is important to note that a design goal such as -85 dBm is usually derived taking into account multipath fading and log-normal shadowing characteristics. Thus, this design goal will only be met “on average” over 95% of the area being covered. At any given point, a fade may bring the signal level underneath the design goal.*

Note that this method of calculating a link budget is only for the downlink path. For information to calculate link budgets for both the downlink and uplink paths, refer to Section 6.4 on page 6-26.

5. **Path Loss Slope:** For a rough estimate, Table 6-14, “Estimated Path Loss Slope for Different In-Building Environments” on page 6-15, shows that a building with 50% hard wall offices and 50% cubicles, at 859 MHz, has an approximate path loss slope (PLS) of 37.6. Given the RF link budget of 95.5 dB, the distance of coverage from each RAU will be 52 meters (170.6 ft). This corresponds to a coverage area of 8,494 sq. meters (91,425 sq. ft.) per RAU (refer to Section 6.2.1 for details on path loss estimation). For this case we assumed a circular radiation pattern, though the actual area covered depends upon the pattern of the antenna and the obstructions in the facility.

Equipment Required: Since you know the building size, you can now estimate the Unison equipment quantities that will be needed. Before any RF levels are tested in the building, you can estimate that two antennas per level will be needed. This assumes no propagation between floors. If there is propagation, you may not need antennas on every floor.

- a. 2 antennas per floor \times 8 floors = 16 RAUs
- b. 16 RAUs \div 8 (maximum 8 RAUs per Expansion Hub) = 2 Expansion Hubs
- c. 2 Expansion Hubs \div 4 (maximum 4 Expansion Hubs per Main Hub) = 1 Main Hub

Check that the fiber and Cat-5 cable distances are as recommended. If the distances differ, use the tables in Section 6.3, "System Gain," on page 6-25 to determine system gains or losses. The path loss may need to be recalculated to assure adequate signal levels in the required coverage distance.

The above estimates assume that all cable length requirements are met. If Expansion Hubs cannot be placed so that the RAUs are within the distance requirement, additional Expansion Hubs may need to be placed closer to the required RAUs locations.

An RF Site Survey and Building Evaluation is required to accurately establish the Unison equipment quantities required for the building. The site survey measures the RF losses within the building to determine the actual PLS, which are used in the final path loss formula to determine the actual requirements of the Unison system.

Example Design Estimate for an 1900 MHz CDMA Application

1. Design goals:

- PCS (1920 MHz = average of the lowest uplink and the highest downlink frequency in 1900 MHz PCS band)
- CDMA provider
- 8 CDMA carriers in the system
- -85 dBm design goal (to 95% of the building) — the minimum received power at the wireless device
- Base station with simplex RF connections

2. **Power Per Carrier:** The tables in Section 6.1, “Maximum Output Power Per Carrier at RAU,” on page 6-3 provide maximum power per carrier information. The 1900 MHz CDMA table (on page 6-9) indicates that Unison can support eight carriers with a recommended maximum power per carrier of 6.5 dBm. The input power should be set to the desired output power minus the system gain.

3. Building information:

- 16 floor building with 9,290 sq. meters (100,000 sq. ft.) per floor; total 148,640 sq. meters (1,600,000 sq. ft.).
- Walls are sheetrock construction, suspended ceiling tiles.
- Antennas used are omni-directional, ceiling mounted.
- Standard office environment, 80% hard wall offices and 20% cubicles.

4. **Link Budget:** In this example, a design goal of -85 dBm is used. Suppose 3 dBi omni-directional antennas are used in the design. Then, the maximum RF propagation loss should be no more than 94.5 dB (6.5 dBm + 3 dBi + 85 dBm) over 95% of the area being covered. *It is important to note that a design goal such as -85 dBm is usually derived taking into account multipath fading and log-normal shadowing characteristics. Thus, this design goal will only be met “on average” over 95% of the area being covered. At any given point, a fade may bring the signal level underneath the design goal.*

Note that this method of calculating a link budget is only for the downlink path. For information to calculate link budgets for both the downlink and uplink paths, refer to Section 6.4 on page 6-26.

5. **Path Loss Slope:** For a rough estimate, Table 6-14, “Estimated Path Loss Slope for Different In-Building Environments” on page 6-15, shows that a building with 80% hard wall offices and 20% cubicles, at 1920 MHz, has an approximate path loss slope (PLS) of 38.1. Given the RF link budget of 94.5 dB, the distance of coverage from each RAU will be 30.2 meters (99 ft). This corresponds to a coverage area of 2,868 sq. meters (30,854 sq. ft.) per RAU (refer to Section 6.2.1 for details on path loss estimation). For this case we assumed a circular radiation pattern, though the actual area covered depends upon the pattern of the antenna and the obstructions in the facility.

- 6. Equipment Required:** Since you know the building size, you can now estimate the Unison equipment quantities needed. Before you test any RF levels in the building, you can estimate that four antennas per level will be needed. This assumes no propagation between floors. If there is propagation, you may not need antennas on every floor.
- a. 4 antennas per floor \times 16 floors = 64 RAUs
 - b. 64 RAUs \div 8 (maximum 8 RAUs per Expansion Hub) = 8 Expansion Hubs
 - c. 8 Expansion Hubs \div 4 (maximum 4 Expansion Hubs per Main Hub) = 2 Main Hubs

Check that the fiber and Cat-5/5E/6 cable distances are as recommended. If the distances differ, use the tables in Section 6.3, "System Gain," on page 6-25 to determine system gains or losses. The path loss may need to be recalculated to assure adequate signal levels in the required coverage distance.

The above estimates assume that all cable length requirements are met. If Expansion Hubs cannot be placed so that the RAUs are within the distance requirement, additional Expansion Hubs may need to be placed closer to the required RAUs locations.

An RF Site Survey and Building Evaluation is required to accurately establish the Unison equipment quantities required for the building. The site survey measures the RF losses within the building to determine the actual PLS, used in the final path loss formula to determine the actual requirements of the Unison system.

** For Japan, see separate addendum - *Japan Specification Document*.

6.3 System Gain

The system gain can be decreased from 15 dB to 0 dB gain in 1 dB increments and the uplink and downlink gains of each RAU can be independently decreased by 10 dB in one step using AdminManager or OpsConsole.^a

6.3.1 System Gain (Loss) Relative to ScTP Cable Length

The recommended minimum length of ScTP cable is 10 meters (33 ft) and the recommended maximum length is 100 meters (328 ft). The system should not be operated with ScTP cable that is less than 10 meters (33 ft) in length, system performance is greatly compromised. If the ScTP cable is longer than 100 meters (328 ft), the gain of the system decreases, as shown in Table 6-27.

Table 6-27 System Gain (Loss) Relative to ScTP Cable Length

ScTP with CAT-5 Extender	ScTP Cable Length	Typical change in system gain (dB)	
		Downlink	Uplink
800 MHz TDMA/AMPS and CDMA; 900 MHz GSM and EGSM; and iDEN			
180 m	110 m / 361 ft	-1.0	-0.7
190 m	120 m / 394 ft	-3.2	-2.4
200 m	130 m / 426 ft	-5.3	-4.1
210 m	140 m / 459 ft	-7.5	-5.8
220 m	150 m / 492 ft	-9.7	-7.6
1800 MHz GSM (DCS); 1900 MHz TDMA, CDMA, and GSM			
180 m	110 m / 361 ft	-1.0	-0.7
190 m	120 m / 394 ft	-4.0	-2.4
200 m	130 m / 426 ft	-6.4	-4.1
210 m	140 m / 459 ft	-8.8	-5.8
220 m	150 m / 492 ft	-11.3	-7.6
2.1 GHz UMTS^a; 1.7/2.1 GHz AWS			
180 m	110 m / 361 ft	-1.0	-0.7
190 m	120 m / 394 ft	-3.2	-2.4
200 m	130 m / 426 ft	-5.3	-4.1
210 m	140 m / 459 ft	-7.5	-5.8
220 m	150 m / 492 ft	-9.7	-7.6

a. For Japan, refer to the separate addendum: *Japan Specification Document*.

6.4 Link Budget Analysis

A link budget is a methodical way to account for the gains and losses in an RF system so that the quality of coverage can be predicted. The end result can often be stated as a “design goal” in which the coverage is determined by the maximum distance from each RAU before the signal strength falls beneath that goal.

One key feature of the link budget is the maximum power per carrier explained in Section 6.1. While the maximum power per carrier is important as far as emissions and signal quality requirements are concerned, it is critical that the maximum signal into the Main Hub never exceed 1W (+30 dBm). Composite power levels above this limit will cause damage to the Main Hub.



WARNING: Exceeding the maximum input power of 1W (+30 dBm) could cause permanent damage to the Main Hub.

NOTE: Visit the ADC customer portal at adc.com for the on-line Link Budget Tool.

6.4.1 Elements of a Link Budget for Narrowband Standards

The link budget represents a typical calculation that might be used to determine how much path loss can be afforded in a Unison design. This link budget analyzes both the downlink and uplink paths. For most configurations, the downlink requires lower path loss and is therefore the limiting factor in the system design. It is for this reason that a predetermined “design goal” for the downlink is sufficient to predict coverage distance.

The link budget is organized in a simple manner: the transmitted power is calculated, the airlink losses due to fading and body loss are summed, and the receiver sensitivity (minimum level a signal can be received for acceptable call quality) is calculated. The maximum allowable path loss (in dB) is the difference between the transmitted power, less the airlink losses, and the receiver sensitivity. From the path loss, the maximum coverage distance can be estimated using the path loss formula presented in Section 6.2.1.

Table 6-28 provides link budget considerations for narrowband systems.

Table 6-28 Link Budget Considerations for Narrowband Systems

Consideration	Description												
BTS Transmit Power	The power per carrier transmitted from the base station output												
Attenuation between BTS and Unison	<p>This includes all losses: cable, attenuator, splitter/combiner, and so forth.</p> <p>On the downlink, attenuation must be chosen so that the maximum power per carrier going into the Main Hub does not exceed the levels given in Section 6.1.</p> <p>On the uplink, attenuation is chosen to keep the maximum uplink signal and noise level low enough to prevent base station alarms but small enough not to cause degradation in the system sensitivity.</p> <p>If the Unison noise figure minus the attenuation is at least 10 dB higher than the BTS noise figure, the system noise figure is approximately that of Unison alone. Refer to Section 6.6 for ways to independently set the uplink and downlink attenuations between the base station and Unison.</p>												
Antenna Gain	The radiated output power includes antenna gain. For example, if you use a 3 dBi antenna at the RAU that is transmitting 0 dBm per carrier, the effective radiated power (relative to an isotropic radiator) is 3 dBm per carrier.												
BTS Noise Figure	This is the effective noise floor of the base station input (usually base station sensitivity is this effective noise floor plus a certain C/I ratio).												
Unison Noise Figure	This is Unison's uplink noise figure, which varies depending on the number of Expansion Hubs and RAUs, and the frequency band. Unison's uplink noise figure is specified for a 1-1-8 configuration. Thus, the noise figure for a Unison system (or multiple systems whose uplink ports are power combined) is $NF(1-1-8) + 10*\log(\# \text{ of Expansion Hubs})$. This represents an upper-bound because the noise figure is lower if any of the Expansion Hub's RAU ports are not used.												
Thermal Noise	<p>This is the noise level in the signal bandwidth (BW).</p> <p>Thermal noise power = $-174 \text{ dBm/Hz} + 10\text{Log}(\text{BW})$.</p> <table border="1" style="margin-left: auto; margin-right: auto;"> <thead> <tr> <th>Protocol</th> <th>Signal Bandwidth</th> <th>Thermal Noise</th> </tr> </thead> <tbody> <tr> <td>TDMA</td> <td>30 kHz</td> <td>-129 dBm</td> </tr> <tr> <td>GSM</td> <td>200 kHz</td> <td>-121 dBm</td> </tr> <tr> <td>iDEN</td> <td>25 kHz</td> <td>-130 dBm</td> </tr> </tbody> </table>	Protocol	Signal Bandwidth	Thermal Noise	TDMA	30 kHz	-129 dBm	GSM	200 kHz	-121 dBm	iDEN	25 kHz	-130 dBm
Protocol	Signal Bandwidth	Thermal Noise											
TDMA	30 kHz	-129 dBm											
GSM	200 kHz	-121 dBm											
iDEN	25 kHz	-130 dBm											
Required C/I ratio	For each wireless standard, a certain C/I (carrier to interference) ratio is needed to obtain acceptable demodulation performance. For narrowband systems, (TDMA, GSM, EDGE, iDEN, AMPS) this level varies from about 9 dB to 20 dB.												
Mobile Transmit Power	The maximum power the mobile can transmit (power transmitted at highest power level setting).												
Multipath Fade Margin	This margin allows for a certain level of fading due to multipath interference. Inside buildings there is often one or more fairly strong signals and many weaker signals arriving from reflections and diffraction. Signals arriving from multiple paths add constructively or destructively. This margin accounts for the possibility of destructive multipath interference. In RF site surveys the effects of multipath fading are typically not accounted for because such fading is averaged out over power level samples taken over many locations.												

Link Budget Analysis

Table 6-28 Link Budget Considerations for Narrowband Systems (continued)

Consideration	Description
Log-normal Fade Margin	This margin adds an allowance for RF shadowing due to objects obstructing the direct path between the mobile equipment and the RAU. In RF site surveys, the effects of shadowing are partially accounted for since it is characterized by relatively slow changes in power level.
Body Loss	This accounts for RF attenuation caused by the user's head and body.
Minimum Received Signal Level	This is also referred to as the "design goal". The link budget says that you can achieve adequate coverage if the signal level is, on average, above this level over 95% of the area covered, for example.

6.4.2 Narrowband Link Budget Analysis for a Microcell Application

Table 6-29 Narrowband Link Budget Analysis: Downlink

Line	Downlink	
Transmitter		
a.	BTS transmit power per carrier (dBm)	33
b.	Attenuation between BTS and Unison (dB)	-23
c.	Power into Unison (dBm)	10
d.	Unison gain (dB)	0
e.	Antenna gain (dBi)	3
f.	Radiated power per carrier (dBm)	13
Airlink		
g.	Multipath fade margin (dB)	6
h.	Log-normal fade margin with 9 dB std. deviation, 95% area coverage, 87% edge coverage	10
i.	Body loss (dB)	3
j.	Airlink losses (not including facility path loss)	19
Receiver		
k.	Thermal noise (dBm/30 kHz)	-129
l.	Mobile noise figure (dB)	7
m.	Required C/I ratio (dB)	17
n.	Minimum received signal (dBm)	-105
p.	Maximum path loss (dB)	+99

- $c = a + b$
- $f = c + d + e$
- $j = g + h + i$
- $n = k + l + m$
- k: in this example, k represents the thermal noise for a TDMA signal, which has a bandwidth of 30 kHz
- $p = f - j - n$

Table 6-30 Narrowband Link Budget Analysis: Uplink

Line	Uplink	
	Receiver	
a.	BTS noise figure (dB)	4
b.	Attenuation between BTS and Unison (dB)	-10
c.	Unison gain (dB)	0
d.	Unison noise figure (dB) 1-4-32	22
e.	System noise figure (dB)	22.6
f.	Thermal noise (dBm/30 kHz)	-129
g.	Required C/I ratio (dB)	12
h.	Antenna gain (dBi)	3
i.	Receive sensitivity (dBm)	-97.4
	Airlink	
j.	Multipath fade margin (dB)	6
k.	Log-normal fade margin with 9 dB std. deviation, 95% area coverage, 87% edge coverage	10
l.	Body loss (dB)	3
m.	Airlink losses (not including facility path loss)	19
	Transmitter	
n.	Mobile transmit power (dBm)	28
p.	Maximum path loss (dB)	106.4

- e: enter the noise figure and gain of each system component (a, b, c, and d) into the standard cascaded noise figure formula

$$F_{sys} = F_1 + \frac{F_2 - 1}{G_1} + \frac{F_3 - 1}{G_1 G_2} + \dots$$

where

$$F = 10^{(\text{Noise Figure}/10)}$$

$$G = 10^{(\text{Gain}/10)}$$

(See Rappaport, Theodore S. *Wireless Communications, Principles, and Practice*. Prentice Hall PTR, 1996.)

- $i = f + e + g - h$
- $m = j + k + l$
- $p = n - m - i$

Therefore, the system is downlink limited but the downlink and uplink are almost balanced, which is a desirable condition.

6.4.3 Elements of a Link Budget for CDMA Standards

A CDMA link budget is slightly more complicated because you must consider the spread spectrum nature of CDMA. Unlike narrowband standards such as TDMA and GSM, CDMA signals are spread over a relatively wide frequency band. Upon reception, the CDMA signal is de-spread. In the de-spreading process the power in the received signal becomes concentrated into a narrow band, whereas the noise level remains unchanged. Hence, the signal-to-noise ratio of the de-spread signal is higher than that of the CDMA signal before de-spreading. This increase is called *processing gain*. For IS-95 and J-STD-008, the processing gain is 21 dB or 19 dB depending on the user data rate (9.6 Kbps for rate set 1 and 14.4 Kbps for rate set 2, respectively). Because of the processing gain, a CDMA signal (comprising one Walsh code channel within the composite CDMA signal) can be received at a lower level than that required for narrowband signals. A reasonable level is -95 dBm, which results in about -85 dBm composite as shown below.

An important issue to keep in mind is that the downlink CDMA signal is composed of many orthogonal channels: pilot, paging, sync, and traffic. The composite power level is the sum of the powers from the individual channels. Table 6-31 shows an example.

Table 6-31 Distribution of Power within a CDMA Signal

Channel	Walsh Code Number	Relative Power Level	
Pilot	0	20%	-7.0 dB
Sync	32	5%	-13.3 dB
Primary Paging	1	19%	-7.3 dB
Traffic	8–31, 33–63	9% (per traffic channel)	-10.3 dB

This table assumes that there are 15 active traffic channels operating with 50% voice activity (so that the total power adds up to 100%). Notice that the pilot and sync channels together contribute about 25% of the power. When measuring the power in a CDMA signal you must be aware that if only the pilot and sync channels are active, the power level will be about 6 to 7 dB lower than the maximum power level you can expect when all voice channels are active. The implication is that if only the pilot and sync channels are active, and the maximum power per carrier table says that you should not exceed 10 dBm for a CDMA signal, for example, then you should set the attenuation between the base station and the Main Hub so that the Main Hub receives 3 dBm (assuming 0 dB system gain).

An additional consideration for CDMA systems is that the uplink and downlink paths should be gain and noise balanced. This is required for proper operation of soft-hand-off to the outdoor network as well as preventing excess interference that is caused by mobiles on the indoor system transmitting at power levels that are not coordinated with the outdoor mobiles. This balance is achieved if the power level transmitted by the mobiles under close-loop power control is similar to the power level transmitted under open-loop power control. The open-loop power control equation is

$$P_{TX} + P_{RX} = -73 \text{ dBm (for Cellular, IS-95)}$$

Link Budget Analysis

$$P_{TX} + P_{RX} = -76 \text{ dBm (for PCS, J-STD-008)}$$

where P_{TX} is the mobile's transmitted power and P_{RX} is the power received by the mobile.

The power level transmitted under closed-loop power control is adjusted by the base station to achieve a certain E_b/N_0 (explained in Table 6-32 on page 6-32). The difference between these power levels, Δ_P , can be estimated by comparing the power radiated from the RAU, $P_{downlink}$, to the minimum received signal, P_{uplink} , at the RAU:

$$\Delta_P = P_{downlink} + P_{uplink} + 73 \text{ dBm (for Cellular)}$$

$$\Delta_P = P_{downlink} + P_{uplink} + 76 \text{ dBm (for PCS)}$$

It's a good idea to keep $-12 \text{ dB} < \Delta_P < 12 \text{ dB}$.

Table 6-32 provides link budget considerations for CDMA systems.

Table 6-32 Additional Link Budget Considerations for CDMA

Consideration	Description
Power per carrier, downlink	<p>This depends on how many channels are active. For example, the signal is about 7 dB lower if only the pilot, sync, and paging channels are active compared to a fully-loaded CDMA signal. Furthermore, in the CDMA forward link, voice channels are turned off when the user is not speaking. On average this is assumed to be about 50% of the time. So, in the spreadsheet, both the power per Walsh code channel (representing how much signal a mobile will receive on the Walsh code that it is de-spreading) and the total power are used.</p> <p>The channel power is needed to determine the maximum path loss, and the total power is needed to determine how hard the Unison system is being driven.</p> <p>The total power for a fully-loaded CDMA signal is given by (approximately):</p> $\begin{aligned} \text{total power} &= \text{voice channel power} + 13 \text{ dB} + 10\log_{10}(50\%) \\ &= \text{voice channel power} + 10 \text{ dB} \end{aligned}$
Information Rate	<p>This is simply</p> $10\log_{10}(9.6 \text{ Kbps}) = 40 \text{ dB for rate set 1}$ $10\log_{10}(14.4 \text{ Kbps}) = 42 \text{ dB for rate set 2}$
Process Gain	<p>The process of de-spreading the desired signal boosts that signal relative to the noise and interference. This gain needs to be included in the link budget. In the following formulas, P_G = process gain:</p> $P_G = 10\log_{10}(1.25 \text{ MHz} / 9.6 \text{ Kbps}) = 21 \text{ dB rate set 1}$ $P_G = 10\log_{10}(1.25 \text{ MHz} / 14.4 \text{ Kbps}) = 19 \text{ dB rate set 2}$ <p>Note that the process gain can also be expressed as $10\log_{10}$ (CDMA bandwidth) minus the information rate.</p>
Eb/No	<p>This is the energy-per-bit divided by the received noise and interference. It's the CDMA equivalent of signal-to-noise ratio (SNR). This figure depends on the mobile's receiver and the multipath environment.</p> <p>If the receiver noise figure is NF (dB), then the receive sensitivity (dBm) is given by:</p> $\begin{aligned} P_{\text{sensitivity}} &= NF + E_b/N_o + \text{thermal noise in a 1.25 MHz band} - P_G \\ &= NF + E_b/N_o - 113 \text{ (dBm/1.25 MHz)} - P_G \end{aligned}$

Table 6-32 Additional Link Budget Considerations for CDMA (continued)

Consideration	Description
Noise Rise	<p>On the uplink, the noise floor is determined not only by the Unison system, but also by the number of mobiles that are transmitting. This is because when the base station attempts to de-spread a particular mobile's signal, all other mobile signals appear to be noise. Because the noise floor rises as more mobiles try to communicate with a base station, the more mobiles there are, the more power they have to transmit. Hence, the noise floor rises rapidly:</p> $\text{noise rise} = 10 \log_{10}(1 / (1 - \text{loading}))$ <p>where <i>loading</i> is the number of users as a percentage of the theoretical maximum number of users. Typically, a base station is set to limit the loading to 75%. This noise ratio must be included in the link budget as a worst-case condition for uplink sensitivity. If there are less users than 75% of the maximum, then the uplink coverage will be better than predicted.</p>
Hand-off Gain	<p>CDMA supports soft hand-off, a process by which the mobile communicates simultaneously with more than one base station or more than one sector of a base station. Soft hand-off provides improved receive sensitivity because there are two or more receivers or transmitters involved. A line for hand-off gain is included in the CDMA link budgets worksheet although the gain is set to 0 dB because the in-building system will probably be designed to limit soft-handoff.</p>

Other CDMA Issues

- Never combine multiple sectors (more than one CDMA signal at the same frequency) into a Unison system. The combined CDMA signals will interfere with each other.
- Try to minimize overlap between in-building coverage areas that utilize different sectors, as well as in-building coverage and outdoor coverage areas. This is important because any area in which more than one dominant pilot signal (at the same frequency) is measured by the mobile will result in soft-handoff. Soft-handoff decreases the overall network capacity by allocating multiple channel resources to a single mobile phone.

6.4.4 CDMA Link Budget Analysis for a Microcell Application

Table 6-33 CDMA Link Budget Analysis: Downlink

Line	Downlink	
Transmitter		
a.	BTS transmit power per traffic channel (dBm)	30.0
b.	Voice activity factor	50%
c.	Composite power (dBm)	40.0
d.	Attenuation between BTS and Unison (dB)	-24
e.	Power per channel into Unison (dBm)	9.0
f.	Composite power into Unison (dBm)	16.0
g.	Unison gain (dB)	0.0
h.	Antenna gain (dBi)	3.0
i.	Radiated power per channel (dBm)	12.0
j.	Composite radiated power (dBm)	19.0
Airlink		
k.	Handoff gain (dB)	0.0
l.	Multipath fade margin (dB)	6.0
m.	Log-normal fade margin with 9 dB std. deviation, 95% area coverage, 87% edge coverage	10.0
n.	Additional loss (dB)	0.0
o.	Body loss (dB)	3.0
p.	Airlink losses (not including facility path loss)	19.0
Receiver		
q.	Mobile noise figure (dB)	7.0
r.	Thermal noise (dBm/Hz)	-174.0
s.	Receiver interference density (dBm/Hz)	-167.0
t.	Information ratio (dB/Hz)	41.6
u.	Required $E_b/(N_o+I_o)$	7.0
v.	Minimum received signal (dBm)	-118.4
w.	Maximum path loss (dB)	+99.4

- b and c: see notes in Table 6-32 regarding power per carrier, downlink
- $e = a + d$
- $f = c + d$
- $i = e + g + h$
- $j = f + g + h$
- $p = -k + l + m + n + o$
- $s = q + r$
- $v = s + t + u$
- $w = j - p - v$
- $x = j$ (downlink) + m (uplink) + P

where

$$P = P_{tx} + P_{rx} = \begin{array}{l} -73 \text{ dB for Cellular} \\ -76 \text{ dB for PCS} \end{array}$$

Table 6-34 CDMA Link Budget Analysis: Uplink

Line	Uplink	
	Receiver	
a.	BTS noise figure (dB)	3.0
b.	Attenuation between BTS and Unison (dB)	-30.0
c.	Unison gain (dB)	0.0
d.	Unison noise figure (dB)	22.0
e.	System noise figure (dB)	33.3
f.	Thermal noise (dBm/Hz)	-174.0
g.	Noise rise 75% loading (dB)	6.0
h.	Receiver interference density (dBm/Hz)	-134.6
i.	Information rate (dB/Hz)	41.6
j.	Required $E_b/(N_o + I_o)$	5.0
k.	Handoff gain (dB)	0.0
l.	Antenna gain (dBi)	3.0
m.	Minimum received signal (dBm)	-91.1
	Airlink	
n.	Multipath fade margin (dB)	6.0
o.	Log-normal fade margin with 9 dB std. deviation, 95% area coverage, 87% edge coverage	10.0
p.	Additional loss (dB)	0.0
q.	Body loss (dB)	3.0
r.	Airlink losses (not including facility path loss)	19.0
	Transmitter	
s.	Mobile transmit power (dBm)	28.0
t.	Maximum path loss (dB)	100.1

- e: enter the noise figure and gain of each system component (a, b, c, and d) into the standard cascaded noise figure formula

$$F_{sys} = F_1 + \frac{F_2 - 1}{G_1} + \frac{F_3 - 1}{G_1 G_2} + \dots$$

where

$$F = 10^{(\text{Noise Figure}/10)}$$

$$G = 10^{(\text{Gain}/10)}$$

(See Rappaport, Theodore S. *Wireless Communications, Principles, and Practice*. Prentice Hall PTR, 1996.)

- $h = e + f + g$
- $m = h + i + j - k - l$
- $r = n + o + p + q$
- $t = s - r - m$

6.4.5 Considerations for Re-Radiation (Over-the-Air) Systems

Unison can be used to extend the coverage of the outdoor network by connecting to a roof-top donor antenna pointed toward an outdoor base station. Additional considerations for such an application of Unison are:

- Sizing the gain and output power requirements for a bi-directional amplifier (repeater).
- Ensuring that noise radiated on the uplink from the in-building system does not cause the outdoor base station to become desensitized to wireless handsets in the outdoor network.
- Filtering out signals that lie in adjacent frequency bands. For instance, if you are providing coverage for Cellular B-band operation it may be necessary to filter out the A, A' and A'' bands which may contain strong signals from other outdoor base stations.

Further information on these issues can be found in ADC application notes for re-radiation applications.

6.5 Optical Power Budget

Unison uses SC/APC connectors. The connector losses associated with mating to these connectors is accounted for in the design and *should not* be included as elements of the optical power budget. The reason is that when the optical power budget is defined, measurements are taken with these connectors in place.

The Unison optical power budget for both multi-mode and single-mode fiber cable is 3.0 dB (optical).

The maximum loss through the fiber can not exceed 3 dB (optical). The maximum lengths of the fiber cable should not exceed 1.5 km (4,921 ft) for multi-mode and 6 km (19,685 ft) for single-mode. Both the optical budget and the maximum cable length must be taken into consideration when designing the system.

NOTE: It is critical to system performance that only SC/APC fiber connectors are used throughout the fiber network, including fiber distribution panels.

6.6 Connecting a Main Hub to a Base Station

The first consideration when connecting Unison Main Hubs to a base station is to ensure there is an equal amount of loss through cables, combiners, and so on from the base station to the Main Hubs. For this example, assume that the base station will have simplex connections, one uplink and one downlink. Each of these connections needs to be divided to equilibrate power for each Main Hub. For example, two Main Hubs require a 2×1 combiner/divider; four Main Hubs require a 4×1 combiner/divider; and so on.

Figure 6-2 Connecting Main Hubs to a Simplex Base Station

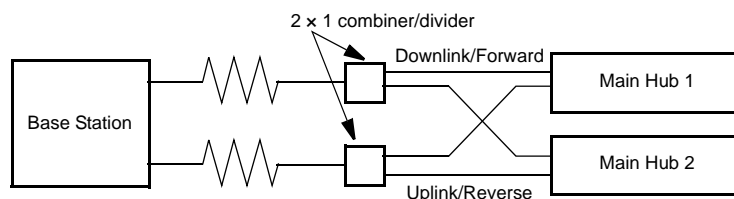

When connecting a Unison Main Hub to a base station, also consider the following:

1. The downlink power from the base station must be attenuated enough so that the power radiated by the RAU does not exceed the maximum power per carrier listed in Section 6.1, “Maximum Output Power Per Carrier at RAU,” on page 6-3.
2. The uplink attenuation should be small enough that the sensitivity of the overall system is limited by Unison, not by the attenuator. However, some base stations trigger alarms if the noise or signal levels are too high. In this case the attenuation has to be large enough to prevent this from happening.

NOTE: The UPLINK and DOWNLINK ports cannot handle a DC power feed from the base station. If DC power is present, a DC block must be used or the hub may be damaged.

If, in an area covered by Unison, a mobile phone indicates good signal strength but consistently has difficulty completing calls, it is possible that the attenuation between Unison and the base station needs to be adjusted. In other words, it is possible that if the uplink is over-attenuated, the downlink power will provide good coverage, but the uplink coverage distance will be small.

When there is an excessive amount of loss between the Main Hub uplink and the base station, the uplink system gain can be increased to as much as 15 dB to prevent a reduction in the overall system sensitivity.

6.6.1 Attenuation

Figure 6-3 shows a typical setup wherein a duplex base station is connected to a Main Hub. For a simplex base station, eliminate the circulator and connect the simplex ports of the base station to the simplex ports of the Main Hub. Add attenuators to regulate the power appropriately.

Figure 6-3 Main Hub to Duplex Base Station or Repeater Connections

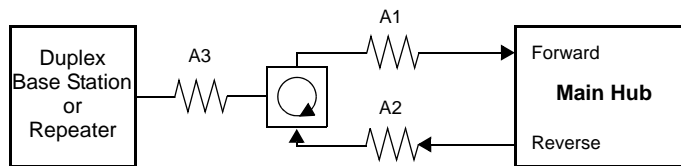

- A typical circulator has an IP3 of +70dBm. If you drive the circulator too hard it produces intermods bigger than the intermods produced by Unison. The IP3 at the Forward port input of the Main Hub is approximately +38 dBm. The IP3 of the circulator at that same point (i.e., following attenuator A1) is +70dBm – A1. Thus, to keep the system IP3 from being adversely affected by the circulator, attenuator A1 should be no more than approximately +30 dB.
- A filter diplexer can be used in place of the circulator. The IP3 of the diplexer can be assumed to be greater than +100 dBm. If a diplexer is used, A3 can be omitted.
- A1+A3 should be chosen so that the output power per carrier at the RAU's output is correct for the number of carriers being transmitted. Suppose the base station transmits 36 dBm per carrier and it is desired that the RAU output be 6 dBm per carrier and the forward port gain is 0 dB. Then A1+A3=30 dB.
- A2+A3 should, ideally, be at least 10 dB less than the noise figure plus the gain of the Unison system. For example, if the reverse port has a 0 dB gain and if there are 32 RAUs, the noise figure is approximately 22 dB. So A2+A3 should be about 10 dB. If A2+A3 is too large, the uplink coverage can be severely reduced.
- Given these three equations:
 - A1 < 30 dB
 - A1+A3 = 30 dB (in this example)
 - A2+A3 < 10 dB (in this example)
 we could choose A1=20 dB, A2=0 dB, A3=10 dB

6.6.2 Uplink Attenuation

The attenuation between the Main Hub's uplink port and the base station does two things:

- It attenuates the noise coming out of Unison.
- It attenuates the desired signals coming out of Unison.

Setting the attenuation on the uplink is a trade-off between keeping the noise and maximum signal levels transmitted from Unison to the base station receiver low while not reducing the SNR (signal-to-noise ratio) of the path from the RAU inputs to the base station inputs. This SNR can not be better than the SNR of Unison by itself, although it can be significantly worse.

For example, suppose we have a GSM Unison system consisting of one Main Hub, four Expansion Hubs, and 32 RAUs (1-4-32) with uplink NF=22 dB. (Refer to Table 6-32 on page 6-32.) If we use 30 dB of attenuation between the Main Hub's uplink port and the base station (which has its own noise figure of about 4 dB), the overall noise figure is 34.3 dB (refer to the formula on page 6-30) which is 12.3 dB worse than Unison by itself. That causes a 12.3 dB reduction in the uplink coverage distance. If the attenuation is 10 dB instead, the cascaded noise figure is NF=22.6 dB, which implies that the uplink sensitivity is limited by Unison, a desirable condition.

Rule of Thumb

A good rule of thumb is to set the uplink attenuation, A2+A3 in Figure 6-3 on page 6-40, as follows:

$$A2+A3 \approx \text{Unison uplink NF} + \text{uplink gain (0 dB for reverse port)} - \text{BTS NF} - 10\text{dB}$$

and round A2 *down* to the nearest convenient attenuation value.

6.6.2.1 Uplink Attenuation Exception: CDMA

In CDMA systems, the power transmitted by the mobile is determined by the characteristics of both the uplink and downlink paths. The power transmitted by the mobile should be similar in open-loop control (as determined by the downlink path) as during closed-loop control (as determined by the uplink and downlink paths). In addition, the mobile's transmit power when it communicates with a base station through Unison should be similar to the power transmitted when it communicates with a base station in the outdoor network (during soft hand-off). Because of these considerations, you should not allow the downlink and uplink gains to vary widely.

Open-loop power control:

$$P_{TX} = -76 \text{ dBm (for PCS)} - P_{RX}$$

where P_{TX} is the power transmitted and P_{RX} is the power received by the mobile. If PL is the path loss (in dB) between the RAU and the mobile, and P_{DL} is the downlink power radiated by the RAU, then

$$P_{TX} = -76 \text{ dBm (for PCS)} - P_{DL} + PL$$

Closed-loop power control:

$$\begin{aligned} P_{TX} &= \text{noise floor} + \text{uplink NF} - \text{process gain} + E_b/N_o + PL \\ &= -113 \text{ dBm/1.25 Mhz} + \text{NF} - 19 \text{ dB} + 7 \text{ dB} + PL \end{aligned}$$

where $E_b/N_o = 7 \text{ dB}$ is a rough estimate, and NF is the cascaded noise figure of the Unison uplink, the uplink attenuation, and the base station noise figure. Equating P_{TX} for the open-loop and closed-loop we see that

$$\text{NF} = 49 - P_{DL}$$

where P_{DL} is determined by the downlink attenuation. Since P_{DL} for Unison is about 10 dBm, the cascaded noise figure is about 39 dB, which is considerably higher than that of Unison itself. This implies that we should use a fairly large attenuation on the uplink. This case suggests using as much attenuation on the downlink as on the uplink. The drawback is that the uplink coverage sensitivity is reduced. A link budget analysis clarifies these issues. Typically, the uplink attenuation between the Main Hub and the base station will be the same as, or maybe 10 dB less than, the downlink attenuation.

6.6.3 RAU Attenuation and ALC

The RAU attenuation and Automatic Level Control (ALC) are set using the OpsConsole or AdminManager Advanced RAU Settings command.

Embedded within the uplink RF front-end of each Unison Remote Access Unit is an ALC circuit. This ALC circuit protects the Unison system from overload and excessive intermodulation products due to high-powered mobiles or other signal sources that are within the supported frequency band and are in close proximity to the RAU.

The Unison uplink ALC circuit operates as a feedback loop. A power detector measures the level of the uplink RF input and if that level exceeds -30 dBm, an RF attenuator is activated. The level of attenuation is equal to the amount that the input exceeds -30 dBm. The following sequence describes the operation of the ALC circuit, as illustrated in Figure 6-4.

1. The RF signal level into the RAU rises above the activation threshold (-30 dBm), causing the ALC loop to enter into the attack phase.
2. During the attack phase, the ALC loop increases the attenuation (0 to 30 dB) until the detector reading is reduced to the activation threshold. The duration of this attack phase is called the attack time.
3. After the attack time, the ALC loop enters the hold phase and maintains a fixed attenuation so long as the high-level RF signal is present.
4. The RF signal level drops below the release threshold (-45 dBm) and the ALC loop enters the release phase.
5. During the release phase, the ALC loop holds the attenuation for a fixed period then quickly releases the attenuation.

An important feature of the ALC loop is that in Step 3, the attenuation is maintained at a fixed level until the signal drops by a significant amount. This prevents the ALC loop from tracking variations in the RF signal itself and distorting the waveform modulation.

Figure 6-4 ALC Operation

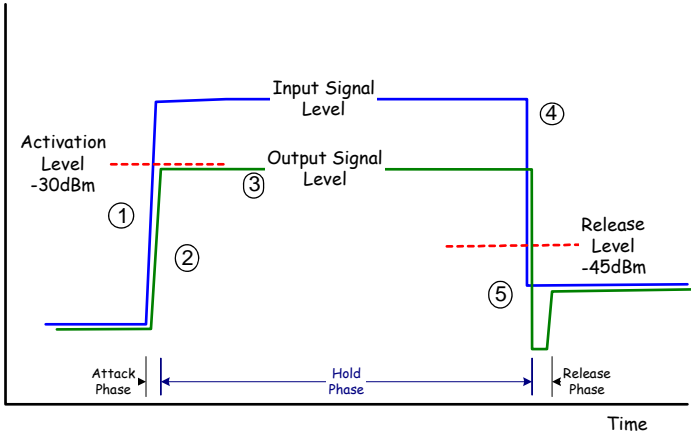

6.6.3.1 Using the RAU 10 dB Attenuation Setting

Each RAU can, independently of the other RAUs in a system, have its uplink or downlink gain attenuated by 10dB.¹ This is accomplished by selecting the check boxes in the Advanced RAU Settings dialog box. There are two check boxes: one for setting the downlink attenuation and another for setting the uplink attenuation.

- **Downlink Attenuation**

The purpose of the downlink attenuator is to provide a mechanism to reduce the signal strength from an RAU. For instance, this could be for an RAU located near a window in a tall building that is causing excessive leakage to the macro-network. In such a case it is important to attenuate the downlink only. The uplink should not be attenuated. If the uplink is attenuated, the uplink sensitivity is reduced and mobile phones in the area of that RAU will have to transmit at a higher power. This would increase interference to the outdoor network from such mobiles.

- **Uplink Attenuation**

The purpose of the uplink attenuator is to attenuate environmental noise picked up by an RAU located in an area where heavy electrical machinery is operating. In such environments the electrical noise can be quite high and it is useful to reduce the amount of such noise that gets propagated through the distributed antenna system. Attenuating the uplink of an RAU located in areas of high electrical noise helps preserve the sensitivity of the rest of the system.

The effect of activating the uplink or downlink attenuators is to reduce the coverage area of the adjusted RAU. The coverage radius will be reduced by roughly a factor of 2. More specifically, if d is the coverage distance without attenuation and d' is the coverage radius with the attenuation, then

$$\frac{d}{d'} = 10^{10dB / PLS}$$

where PLS is the path loss slope.

1. With UMTS-2 RAU, a higher granularity of gain control is provided in 1dB increments, giving a better gain control and fine-tuning capability.

6.6.3.2 Using the Uplink ALC Setting

Uplink automatic level control (UL ALC) circuitry within the RAU provides automatic level control on high-power signals in the uplink path. This functionality is required to prevent RF signal compression caused by a single or multiple wireless devices that are in very close proximity to an RAU. Compression causes signal degradation and, ultimately, bit errors, and should be prevented. Two settings are available to optimize UL ALC performance:

- **Single Operator and Protocol:** Use when only one operator and protocol is on-the-air within the Unison system's configured and adjacent frequency bands (rarely used).
- **Multiple Operators:** Use when more than one operator and/or protocol is present in the Unison system's frequency or adjacent frequency bands (almost always used).

Table 6-35 shows the frequency bands that are adjacent to the bands of which the system is configured.

Table 6-35 Frequency Bands Adjacent to System Configured Bands

System Configuration	Adjacent Bands
iDEN	Cellular
Cellular	iDEN
PCS ADB	PCS E
PCS DBEF	PCS A, PCS C
PCS EFC	PCS B
PCS A4, A5, D, B, E	F
PCS A5, D, B, E, F	C
PCS D, B, E, F, C2	A
PCS B4, B5, E, F, C	A ₁
DCS 1	DCS 2, DCS 4
DCS 2	DCS 1, DCS 4
DCS4	DCS 1, DCS 2
UMTS 1	UMTS 2, UMTS 3
UMTS 2	UMTS 1, UMTS 3
UMTS 3	UMTS 1, UMTS 2
AWS1	AWS2
AWS2	AWS1
PS700	iDEN, 700 UC
700 UC	PS700

6.7 Designing for a Neutral Host System

Designing for a neutral host system uses the same design rules previously explained. Since a neutral host system typically uses *multiple systems in parallel* with common equipment locations, it is best to design according to the minimum among the systems' RAU coverage distances so that there will not be holes in the coverage area, and so that the economies of a single installation can be achieved. For example, as indicated in Section 7.1, the 1900 MHz RF signals do not propagate throughout a building as well as the 800 MHz signals. Therefore, we design using the 1900 MHz radiated distance, calculated with the path loss slope formula.

The example neutral host system described below consists of one iDEN, one 800 MHz, and two 1900 MHz systems and can support up to seven separate service providers in the following manner:

- 1 on iDEN
- 2 on 800 MHz, A band and B band
- 2 in each of the two 1900 MHz frequency sub-bands

Example Unison Neutral Host System

The following example configuration was designed to provide:

- Similar coverage per band in an office environment that is 80% cubicles and 20% offices.
- Similar capacity.
- Support for up to 7 Operators, where equipment has been shared to minimize the number of parallel systems.

Example Configuration:

- 800 MHz iDEN: 16 channels (3 dBm)
- 800 MHz Cellular (3 dBm)
 - TDMA Band: 14 channels (shared)
 - CDMA Band: 3 channels (shared)
- 1900 MHz PCS (6 dBm)
 - TDMA Band: 14 channels
 - CDMA Band: 3 channels (shared)
 - GSM Band: 6 channels (shared)

Similar coverage is achieved by setting the transmit power per carrier of the 800 MHz systems to 3 dBm per carrier and those of the 1900 MHz systems to 6 dBm per carrier.

The numbers of RF carriers were selected in order to match subscriber capacity approximately. Because each protocol in the example supports a different number of voice channels, the RF carrier numbers also differ. As Table 6-36 indicates, the 800 MHz Cellular and shared 1900 MHz systems can support additional RF carriers without decreasing the power per carrier figures.

For logistical reasons, operators involved in a neutral host system sometimes prefer not to share equipment with other operators. From technical and economic perspectives, too, this can be a prudent practice in medium to high-capacity installations. Though deploying parallel systems appears to increase the amount of equipment needed as well as the system cost, the trade-off between capacity and coverage must be considered because, in short, as capacity increases, coverage area per RAU decreases. Therefore, more RAUs (and perhaps Expansion Hubs and Main Hubs) are needed to cover a given floor space.

Table 6-36 shows the capacities of both 800 and 1900 MHz Unison systems used for single and multiple protocol applications. The power per carrier for each system is based on providing equal coverage areas for both systems when they are used in an office building that is 80% cubicles and 20% offices.

Table 6-36 Unison Capacity: Equal Coverage Areas

Operator #1				Operator #2			
Protocol	RF Chs	Voice Chs	Subscribers	Protocol	RF Chs	Voice Chs	Subscribers
800 MHz Cellular A/B (Unison); 3 dBm power per carrier							
TDMA only	35	104	1837	N/A	—	—	—
CDMA only	12	180–240	3327–4517	N/A	—	—	—
TDMA (combining with CDMA: Operator #2)	15	44	694	CDMA (combining with TDMA: Operator #1)	10	150–200	2736–3723
	20	59	974		7	105–140	1856–2540
	25	74	1259		4	60–80	993–1374
	28	83	1431		2	30–40	439–620
800 MHz iDEN (Unison); 3 dBm power per carrier							
iDEN only	16	47	749	N/A	—	—	—
1900 MHz PCS (Unison); 6 dBm power per carrier							
TDMA only	14	41	638	N/A	—	—	—
CDMA only	10	150–200	2736–3723	N/A	—	—	—
GSM only	14	111	1973	N/A	—	—	—
TDMA (combining with CDMA: Operator #2)	6	17	213	CDMA (combining with TDMA: Operator #1)	4	60–80	993–1374
	8	23	315		3	45–60	712–993
	10	29	421		2	30–40	439–620
	11	32	474		1	15–20	180–264
TDMA (combining with GSM: Operator #2)	6	17	213	GSM (combining with TDMA: Operator #1)	7	55	899
	8	23	315		5	39	602
	10	29	421		3	23	315
	11	32	474		2	15	180
CDMA (combining with GSM: Operator #2)	2	30–40	439–620	GSM (combining with CDMA: Operator #1)	10	79	1355
	4	60–80	993–1374		7	55	899
	6	90–120	1566–2148		4	31	457
	8	120–200	2148–2933		1	7	59

Note 1

The RF channel capacity limits are based on the Unison data sheets' "typical" specifications for fiber length, Cat-5 length, and RF performance.

Note 2

The subscriber capacity limits are based on the Erlang B traffic model with a 2% GOS. Each user has a 50mErlangs, which is higher than the standard 35mErlangs.

Installing Unison

7.1 Installation Requirements

Before and during installation, keep in mind the following sources of potential problems:

- Faulty cabling/connector
- Dirty connectors and ports
- Malfunction of one or more Unison components
- Antenna, base station, or repeater problem
- External RF interface
- Tripped circuit breaker
- Equipment is not grounded
- Using a Null modem cable that does not support full hardware handshaking when using AdminManager

NOTE: Faulty cabling is the cause of a majority of problems. All Cat-5E/6 cable should be tested to TIA/EIA 568-A specifications. **The RAU will be damaged if the cable is not wired correctly.**

7.1.1 Component Location Requirements

Unison components are intended to be installed in indoor locations only.

7.1.2 Cable and Connector Requirements

The Unison equipment operates over:

- Category 5E or 6 (Cat-5E/6) screened twisted pair (ScTP) cable with shielded RJ-45 connectors
- Single-mode fiber (SMF) or multi-mode fiber (MMF) cable with SC/APC fiber connectors throughout the fiber network, including fiber distribution panels

These cables are widely used industry standards for Local Area Networks (LANs). The regulations and guidelines for Unison cable installation are identical to those specified by the TIA/EIA 568-A standard and the TIA/EIA/IS-729 supplement for LANs.

ADC recommends plenum-rated Cat-5E/6 ScTP and fiber cable and connectors for conformity to building codes and standards.

Belden 1533P DataTwist® Five ScTP cable, or equivalent is required for Cat-5E.

Commscope® 5ES4/5ENS4 may also be used for Cat-5E.

NOTE: In order to meet FCC and CE Mark emissions requirements, the Cat-5E/6 cable must be screened (ScTP) and it must be grounded using shielded RJ-45 connectors at both ends.

7.1.3 Multiple Operator System Recommendations

As in any Unison system, a multiple operator (neutral host) system requires one pair of fiber strands between each Main Hub and each Expansion Hub, and one Cat-5E/6 cable between each Expansion Hub and each RAU. In situations where Hubs and/or RAUs will be installed in the future to support the addition of frequency bands and/or wireless Operators, it is advantageous to install the necessary cabling initially. Such deployment typically leads to substantial cost savings over installing parallel cabling at separate times.

7.1.4 Distance Requirements

Table 7-1 shows the distances between Unison components and related equipment.

Table 7-1 Unison Distance Requirements

Equipment Combination	Cable Type	Distance	Additional Information
Repeater to Main Hub	Coaxial; N male connectors	3–6 m (10–20 ft) typical 10 m (33 ft) maximum	Limited by loss and noise. Refer to your link budget calculation. Limited by CE Mark requirements.
Base Station to Main Hub	Coaxial; N male connectors	3–6 m (10–20 ft) typical 10 m (33 ft) maximum	Limited by loss and noise. Refer to your link budget calculation. Limited by CE Mark requirements.
Main Hub to Expansion Hub	Multi-mode Fiber: Single-mode Fiber: SC/APC male connectors	1.5 km (4,921 ft) max. 6 km (19,685 ft) max.	Limited by 3 dB optical loss.
Expansion Hub to RAU	Cat-5E/6 ScTP; shielded RJ-45 male connectors	<ul style="list-style-type: none"> • Minimum: 10 meters (33 ft) • Recommended Max.: 100 meters (328 ft) See Section 7.4.5 if using a Cat-5 Extender	Refer to “System Gain (Loss) Relative to ScTP Cable Length” on page 6-25.
RAU to passive antenna	Coaxial; SMA male connectors	1–3.5 m (3–12 ft) typical	Limited by loss and noise. Refer to your link budget calculation.

7.2 Safety Precautions

7.2.1 Installation Guidelines

Use the following guidelines when installing ADC equipment:

- Provide sufficient airflow and cooling to the equipment to prevent heat build-up from exceeding the maximum ambient air temperature specification. Do not compromise the amount of airflow required for safe operation of the equipment.
- If you are removing the system, turn it off and remove the power cord first. There are no user-serviceable parts inside the components.
- The internal power supply has internal fuses that are not user replaceable. Consider the worst-case power consumption shown on the product labels when provisioning the equipment's AC power source and distribution.

7.2.2 General Safety Precautions

The following precautions apply to ADC products:

- The units have no user-serviceable parts. Faulty or failed units are fully replaceable through ADC. Please contact ADC at:
1-800-530-9960 (U.S. only)
+1-408-952-2400 (International)
- Although modeled after an Ethernet/LAN architecture and connectivity, the units are not intended to connect to Ethernet data hubs, routers, cards, or other similar data equipment.
- When you connect the fiber optic cable, take the same precaution as if installing Ethernet network equipment. All optical fiber SC/APC connectors should be cleaned according to the cable manufacturer's instructions.
- When you connect a radiating antenna to an RAU, **firmly** hand-tighten the SMA female connector – DO NOT over-tighten the connector.



WARNING: To reduce the risk of fire or electric shock, do not expose this equipment to rain or moisture. The components are intended for indoor use only. Do not install the RAU outdoors. Do not connect an RAU to an antenna that is located outside where it could be subject to lightning strikes, power crosses, or wind.

7.2.3 Fiber Port Safety Precautions

The following are suggested safety precautions for working with fiber ports. For information about system compliance with safety standards, refer to Appendix B.



WARNING: Observe the following warning about viewing fiber ends in ports. Do not stare with unprotected eyes at the connector ends of the fibers or the ports of the hubs. Invisible infrared radiation is present at the front panel of the Main Hub and the Expansion Hub. Do not remove the fiber port dust caps unless the port is going to be used. Do not stare directly into a fiber port.

- **Test fiber cables:** When you test fiber optic cables, connect the optical power source last and disconnect it first. Use Class 1 test equipment.
- **Fiber ends:** Cover any unconnected fiber ends with an approved cap. Do not use tape.
- **Broken fiber cables:** Do not stare with unprotected eyes at any broken ends of the fibers. Laser light emitted from fiber sources can cause eye injury. Avoid contact with broken fibers; they are sharp and can pierce the skin. Report any broken fiber cables and have them replaced.
- **Cleaning:** Be sure the connectors are clean and free of dust or oils. Use only approved methods for cleaning optical fiber connectors.
- **Modifications:** Do not make any unauthorized modifications to this fiber optic system or associated equipment.
- **Live work:** Live work is permitted because ADC equipment is a Class 1 hazard.
- **Signs:** No warning signs are required.
- **Class 1 laser product:** The system meets the criteria for a Class 1 laser product per IEC 60825-1:1998-01 and IEC 60825-2:2000-05.

**CLASS 1
LASER PRODUCT**

This label appears on the front panel of the Main Hub and the Expansion Hub.

In addition, it is certified by the FDA to meet 21CFR, Chapter 1, Subchapter J.

LEO WIRELESS INC. UNS-1-MH-1
San Jose, CA. 95134 November 2001

This product complies with 21 CFR, Chapter 1, Subchapter J.

This device complies with Part 15 of the FCC rules. Operation is subject to the following two conditions: (1) This device may not cause harmful interference, and (2) this device must accept any interference received, including interference that may cause undesired operation.

This example label appears on the bottom of the Main Hub and a similar one appears on the bottom of the Expansion Hub

- **CAUTION:** Use of controls or adjustments or performance of procedures other than those specified herein may result in hazardous radiation exposure.

7.3 Preparing for System Installation

7.3.1 Pre-Installation Inspection

Follow this procedure before installing Unison equipment:

1. Verify the number of packages received against the packing list.
2. Check all packages for external damage; report any external damage to the shipping carrier. If there is damage, a shipping agent should be present before you unpack and inspect the contents because damage caused during transit is the responsibility of the shipping agent.
3. Open and check each package against the packing slip. If any items are missing, contact ADC customer service.
4. If damage is discovered at the time of installation, contact the shipping agent.

7.3.2 Installation Checklist

Table 7-2 Installation Checklist

✓	Installation Requirement	Consideration
	Floor Plans	Installation location of equipment clearly marked
	System Design	Used to verify frequency bands after installation
	Power available**: Main Hub (AC) Expansion Hub (AC) To RAU (DC)	Power cord is 2 m (6.5 ft) long**. Rating: 100–240V, 0.5A, 50–60 Hz Rating: 115/230V, 5/2.5A, 50–60 Hz 36V (from the Expansion Hub)
	Rack space available: Main Hub Expansion Hub	44 mm (1.75 in.) high (1U) 89 mm (3.5 in.) high (2U)
	Clearance for air circulation: Main and Expansion Hubs RAU	76 mm (3 in.) front and rear, 51 mm (2 in.) sides 76 mm (3 in.) all around
	Suitable operating environment**: Main and Expansion Hubs RAUs	Indoor location only 0° to +45°C (+32° to +113°F) 5% to 95% non-condensing humidity –25° to +45°C (–13° to +113°F) 5% to 95% non-condensing humidity
Donor Antenna-to-Unison Configuration		
	Donor Antenna	Installed, inspected; N-male to N-male coaxial cable to lightning arrestor/surge suppressor
	Lightning Arrestor or Surge Suppressor	Installed between roof-top antenna and repeater; N-male to N-male coaxial cable
	Repeater	Installed between lightning arrestor/surge suppressor and Main Hub; N-male to N-male coaxial cable

Table 7-2 Installation Checklist (continued)

✓	Installation Requirement	Consideration
	Attenuator	Installed between the circulator and the Main Hub downlink port to prevent overload. Optionally, it may be installed between the uplink port and the circulator
	Circulator or Duplexer	Installed between the repeater and the Main Hub uplink and downlink ports
Base Station-to-Unison Configuration		
	Base Station	Verify RF power (refer to the tables in Section 6.1 on page 6-3); N-male to N-male coaxial cable; installed, inspected
	Attenuator	Attenuation may be required to achieve the desired RF output at the RAU and the desired uplink noise floor level
	Circulator or Duplexer	When using a duplex BTS: Installed between the BTS and the Main Hub uplink and downlink ports. Not used with a simplex BTS

** For Japan, see separate addendum - *Japan Specification Document* - for power cord use.

Connecting LGCell Main Hub(s) to a Unison Main Hub

5-port Alarm Daisy-Chain Cable (PN 4024-3)	For normally closed (NC) contact alarm monitoring: connecting 2 to 21 LGCell Main Hubs to a Unison Main Hub If connecting LGCell to Unison, the Alarm Sense Adapter Cable is required to connect the daisy-chain cable to Unison Do not combine LGCell Main Hubs with Unison Main Hubs in the same daisy chain
Alarm Sense Adapter Cable (PN 4024-3)	Use with 5-port Alarm Daisy-Chain Cable to connect up to 21 LGCell Main Hubs to a Unison Main Hub Also, use this cable to connect a single LGCell Main Hub to a Unison Main Hub

Connecting Multiple Unison Main Hubs Together

5-port Alarm Daisy-Chain Cable (PN 4024-3)	For normally closed (NC) contact alarm monitoring of fault and warning alarms. Use to feed the alarms from multiple Unison Main Hubs into a BTS or Flex-Wave Focus Do not combine Unison Main Hubs with LGCell Main Hubs in the same chain.
--	--

Cabling

Coaxial: repeater or base station to Main Hub	Coax approved; N-type male connectors
Coaxial: RAU to passive antennas	Use low-loss cable; SMA male connector; typical 1 m (3.3 ft) using RG142 coaxial cable

Table 7-2 Installation Checklist (continued)

✓	Installation Requirement	Consideration									
	Fiber: Main Hub to Expansion Hubs	<p>SC/APC (angle-polished) male connectors for entire fiber run (can use SC/APC pigtails, PN 4012SCAPC-10 for MMF or 4013SCAPC-10 for SMF);</p> <p>Use jumper fiber cables for collocated Main and Expansion Hubs (3 m/10 ft): Multi-mode: PN 4010SCAPC-10 Single-mode: PN: 4018SCAPC-10</p> <p>Distance limited by optical loss of 3 dB: Multi-mode: up to 1.5 km (4,921 ft); Single-mode: up to 6 km (19,685 ft)</p>									
	Cat-5E/6 ScTP: Expansion Hub to RAUs	<p>TIA/EIA 568-A approved; shielded RJ-45 male connectors. ScTP cable must be screened and it must be grounded at both connector ends</p> <p>Tie-off cables to avoid damaging the connectors because of cable strain</p> <ul style="list-style-type: none"> • Minimum: 10 meters (33 ft) • Recommended Maximum: 100 meters (328 ft) 									
	Cat-5E/6 ScTP: Expansion Hub to Cat-5 Extender to RAU**	<table border="1" style="width: 100%; border-collapse: collapse;"> <thead> <tr> <th style="text-align: center;">Minimum Cat-5E/6 Cable Length from Expansion Hub to Extender</th> <th style="text-align: center;">Minimum Cat-5E/6 Cable Length from Extender to RAU</th> <th style="text-align: center;">Maximum Total Cat-5E/6 Cable Length from Expansion Hub to RAU</th> </tr> </thead> <tbody> <tr> <td style="text-align: center;">90 meters</td> <td style="text-align: center;">20 meters</td> <td style="text-align: center;">110 to 170 meters</td> </tr> <tr> <td style="text-align: center;">295 feet</td> <td style="text-align: center;">65 feet</td> <td style="text-align: center;">360 to 557 feet</td> </tr> </tbody> </table> <p>** For Japan, see separate addendum - <i>Japan Specification Document</i>.</p>	Minimum Cat-5E/6 Cable Length from Expansion Hub to Extender	Minimum Cat-5E/6 Cable Length from Extender to RAU	Maximum Total Cat-5E/6 Cable Length from Expansion Hub to RAU	90 meters	20 meters	110 to 170 meters	295 feet	65 feet	360 to 557 feet
Minimum Cat-5E/6 Cable Length from Expansion Hub to Extender	Minimum Cat-5E/6 Cable Length from Extender to RAU	Maximum Total Cat-5E/6 Cable Length from Expansion Hub to RAU									
90 meters	20 meters	110 to 170 meters									
295 feet	65 feet	360 to 557 feet									
Configuring System											
	PC/laptop running AdminManager software	Refer to the <i>AdminManager User Manual</i> (PN 8810-10)									
Miscellaneous											
	Null modem cable	Female connectors; Main Hub to a PC/laptop that is running the AdminManager software; local connection									
	Straight-through cable	Female/male connectors; Main Hub to a modem; remote connection									
	Cat-5 Extender	Used if Cat-5E/6 run(s) will exceed 100 meters									
	Dual-Band Diplexer	Used in dual band systems to combine the output of a low-band RAU and a high-band RAU to a single dual band antenna									
Distances											
	Main Hub is within 3–6m (10–20 ft) of connecting repeater	If longer distance, determine the loss of the cable used for this connection and adjust the RF signal into the Main Hub accordingly. This can be done by readjusting the power from the base station, or by changing the attenuation value between the base station/repeater and the Main Hub									
	Main Hub is within 3–6m (10–20 ft) of connecting base station										
	Main Hub is within correct distance of Expansion Hub(s); SMF and MMF optical link budget: 3 dB										

7.3.3 Tools and Materials Required

Table 7-3 Tools and Materials Required for Component Installation

✓	Description
	Cable ties
	Phillips screwdriver
	7-inch lb. torch wrench
	Mounting screws and spring nuts
	Fiber cleaning supplies: compressed air; isopropyl alcohol; lint-free cloths; 2.5mm lint-free, foam tipped swabs;
	Compressed air
	Screws, anchors (for mounting RAUs)
	Drill
	Fiber connector cleaning kit
	Fusion splicer
	Splicing tool kit (including: snips, cladding strippers, fiber cleaver, isopropyl alcohol, lint-free wipes)
	Fusion splicing sleeves

7.3.4 Optional Accessories

Table 7-4 Optional Accessories for Component Installation

✓	Description
	Wall-mount equipment rack(s) (PN 4712) Note that if using this rack with an Expansion Hub, the Hub's mounting bracket must be moved to the center mounting position.
	Cable management (Cable manager: PN 4759; Tie wrap bar: PN 4757)
	Splice trays
	Pigtails with SC/APC connectors, 3 m (10 ft): Multi-mode Fiber SC/APC Pigtail (PN 4012SCAPC-10) Single-mode Fiber SC/APC Pigtail (PN 4013SCAPC-10)
	Jumper cable when Main and Expansion Hubs are collocated, 3 m (10 ft): Single-mode Fiber SC/APC (PN 4018SCAPC-10)
	Teltone Line Sharing Switch (M-394-B-01) When using a single POTS line with multiple Main Hub/Modems: Connect up to four modems to a line sharing switch; can cascade switches to accommodate up to 16 modems per POTS line

Table 7-4 Optional Accessories for Component Installation (continued)

✓	Description
	Alarm Cables: 5-port Alarm Daisy-Chain Cable (PN 4024-3) Alarm Sense Adapter Cable (PN 4025-1)
	RAU Dust Cover (PN UNS-1RDP-1)

7.4 Unison Component Installation Procedures

The following procedures assume that the system is new from the factory.

If you are replacing components in a pre-installed system with either new units or units that may already be programmed (that is, re-using units from another system), refer to Section 8.

- Installing a Main Hub 7-13
 - Installing a Main Hub in a Rack 7-13
 - Installing an Optional Cable Manager in the Rack 7-13
 - Connecting the Fiber Cables to the Main Hub 7-14
- Installing Expansion Hubs 7-18
 - Installing an Expansion Hub in a Rack 7-18
 - Installing an Expansion Hub in a Wall-Mounted Rack 7-18
 - Installing an Optional Cable Manager in the Rack 7-19
 - Powering On the Expansion Hub 7-19
 - Connecting the Fiber Cables to the Expansion Hub 7-20
 - Connecting the ScTP Cables 7-21
 - Troubleshooting Expansion Hub LEDs During Installation 7-22
- Installing RAUs 7-23
 - Installing RAUs 7-23
 - Installing Passive Antennas 7-23
 - Connecting the Antenna to the RAU 7-25
 - Connecting the ScTP Cable 7-25
 - Troubleshooting RAU LEDs During Installation 7-26
 - Installing RAUs in a Dual Band System 7-27
 - Connecting the Antenna to the Dual Band Diplexer 7-29
- Configuring the System 7-30
 - Configuring the Installed System 7-31

The following procedure is for splicing pigtails to fiber cable.

- Splicing Fiber Optic Cable 7-33
 - Fusion Splicing of Fiber and Pigtail 7-33

The following procedures assume that the system is installed and programmed.

- Interfacing a Main Hub to a Base Station or a Roof-top Antenna 7-35
 - Connecting a Main Hub to an In-Building Base Station 7-35
 - Connecting a Main Hub to Multiple Base Stations 7-37
 - Connecting a Main Hub to a Roof-top Antenna 7-37
- Connecting Multiple Main Hubs 7-38
 - Connecting Multiple Main Hubs to a Simplex Repeater or Base Station . 7-38
 - Connecting Multiple Main Hubs to a Duplex Repeater or Base Station . . 7-40
- Connecting Contact Alarms to a Unison System 7-42
 - Alarm Source 7-43
 - Alarm Sense 7-46
 - Alarm Cables 7-49
- Alarm Monitoring Connectivity Options 7-51
 - Direct Connection 7-51
 - Modem Connection 7-52
 - RS-232 Port Expander Connection 7-53
 - POTS Line Sharing Switch Connection 7-54
 - Ethernet and ENET/RS-232 Serial Hub Connection 7-55

7.4.1 Installing a Main Hub



CAUTION: Install Main Hubs in indoor locations only.

✓ Installing a Main Hub in a Rack

Install the Main Hub (1U high) in a standard 19 in. (483 mm) equipment rack. Allow clearance of 76 mm (3 in.) front and rear, and 51 mm (2 in.) on both sides for air circulation. No top and bottom clearance is required.

Consideration:

- The Main Hub is shipped with #10-32 mounting screws. Another common rack thread is #12-24. Confirm that the mounting screws match the rack's threads.

To install the hub in a rack:

1. Insert spring nuts into the rack where needed or use existing threaded holes.
2. Place the Main Hub into the rack from the front.
3. Align the flange holes with the spring nuts installed in Step 1.
4. Insert the mounting screws in the appropriate positions in the rack.
5. Tighten the mounting screws.

Rack-mounting Option

You can flip the rack mounting brackets, as shown in Figure 7-1, so the hub can be mounted 76 mm (3 in.) forward in the rack.

Figure 7-1 Mounting Bracket Detail



✓ Installing an Optional Cable Manager in the Rack

- Using the screws provided, fasten the cable manager to the rack, immediately above or below the Main Hub.

✓ Connecting the Fiber Cables to the Main Hub

Considerations:

- Before connecting the fiber cables, confirm that their optical loss does not exceed the 3 dB optical budget.
- If you are using fiber distribution panels, confirm that the total optical loss of fiber cable, from the Main Hub through distribution panels and patch cords to the Expansion Hub, does not exceed the optical budget.
- Make sure the fiber cable's connectors are SC/APC (angle-polished). Using any other connector type will result in degraded system performance and may damage the equipment. (You can use an SC/APC pigtail if the fiber cable's connectors are not SC/APC. Refer to "Fusion Splicing of Fiber and Pigtail" on page 7-33. Or, you can change the fiber's connector to SC/APC.)

NOTE: Observe all Fiber Port Safety Precautions listed in Section 7.2.3 on page 7-5.

To clean the fiber ports:

You can clean the Hub's fiber ports using canned compressed air or isopropyl alcohol and foam tipped swabs.

Considerations:

- If using compressed air:
 - The air must be free of dust, water, and oil.
 - Hold the can level during use.
- If using isopropyl alcohol and foam tipped swabs:
 - Use only 98% pure or more alcohol

Procedure using compressed air:

1. Remove the port's dust cap.
2. Spray the compressed air away from the unit for a few seconds to clean out the nozzle and then blow dust particles out of each fiber port.

Procedure using isopropyl alcohol:

1. Remove the connector's dust cap.
2. Dip a 2.5mm lint-free, foam-tipped swab in isopropyl alcohol and slowly insert the tip into the connector.
3. Gently twist the swab to clean the port.
4. Insert a dry swab into the port to dry it.

Additionally, you can use compressed air after the alcohol has completely evaporated.

To clean the fiber ends:

Be sure that the fiber cable's SC/APC connectors are clean and free of dust and oils. You need lint-free cloths, isopropyl alcohol, and compressed air

1. Moisten a lint-free cloth with isopropyl alcohol.
2. Gently wipe the fiber end with the moistened cloth.
3. Using a dry lint-free cloth, gently wipe the fiber end.
4. Spray the compressed air away from the connector for a few seconds to clean out the nozzle and then use it to completely dry the connector.

To test the fiber cables:

Perform cable testing and record the results. Test results are required for the final As-Built Document.

To connect the fiber cables:

The fiber cable is labeled with either **1** or **2**, or is color-coded. In addition to these labels, you should add a code that identifies which port on the Main Hub is being used and which Expansion Hub the cables are intended for. This differentiates the connectors for proper connection between the Main Hub and Expansion Hubs.

For example:

First pair to Main Hub port 1: 11 (uplink), 12 (downlink);

Second pair to Main Hub port 2: 21 (uplink), 22 (downlink);

Third pair to Main Hub port 3: 31 (uplink), 32 (downlink); and so on.

If the fiber jumper is labeled with **1** or **2**:

1. Connect **1s** to **UPLINK** ports on the Main Hub.
2. Connect **2s** to **DOWNLINK** ports on the Main Hub.
3. Record which cable number and port number you connected to **UPLINK** and **DOWNLINK**.

This information is needed when connecting the other end of the fiber cable to the Expansion Hub's fiber ports.

The fiber port LEDs should be off, indicating that the Expansion Hub(s) are not connected.

If the fiber jumper is color-coded (for example, "blue" or "red"):

1. Connect "blue" to **UPLINK** ports on the Main Hub.
2. Connect "red" to **DOWNLINK** ports on the Main Hub.
3. Record which color and port number you connected to **UPLINK** and **DOWNLINK**.

This information is needed when connecting the other end of the fiber cable to the Expansion Hub's fiber ports.

The fiber port LEDs should be off, indicating that the Expansion Hub(s) are not connected.

 **Powering On the Main Hub**

1. Connect the AC power cord to the Main Hub.
2. Plug the power cord into an AC power outlet.
3. Turn on the power to the Main Hub and check that all the LED lamps are functioning properly.

Upon power-up, the LEDs blinks for five seconds as a visual check that they are functioning. After the five-second test:

LED states during power on will vary, depending on whether Expansion Hubs are connected. Refer to Table 7-5 for possible combinations.

Table 7-5 Troubleshooting Main Hub LEDs During Installation

During Installation Power On	LED	State	Action	Impact
1. Main Hub power is On with no Expansion Hubs connected.	POWER	Off	Check AC power; check that the Main Hub power-on switch is on; replace the Main Hub	The Main Hub is not powering on.
	POWER	Red	Replace the Main Hub	The power supply is out-of-specification.
	LINK	LEDs are on but they didn't blink through all states	Replace the Main Hub.	The micro controller is not resetting properly; flash memory corrupted.
	E-HUB/RAU			
	LINK	Red	The port is unusable; replace the Main Hub when possible.	Fiber sensor fault, do not use the port.
E-HUB/RAU	Off			

Table 7-5 Troubleshooting Main Hub LEDs During Installation (continued)

During Installation Power On	LED	State	Action	Impact
2. Main Hub power is On with Expansion Hubs connected and powered on.	LINK	Off	<ul style="list-style-type: none"> If the port LEDs do not illuminate, check the fiber uplink for excessive optical loss. If Expansion Hub's DL STATUS LED is red: <ul style="list-style-type: none"> Verify that the fiber is connected to the correct port (that is, uplink/downlink) Swap the uplink and downlink cables. Connect the fiber pair to another port. If the second port's LEDs do not illuminate Green/Red, replace the Main Hub. If the second port works, flag the first port as unusable; replace the Main Hub when possible. 	No uplink optical power, the Expansion Hub is not recognized as being present. No communication with the Expansion Hub.
	E-HUB/RAU	Off		
	LINK	Red	<ul style="list-style-type: none"> If the Expansion Hub DL STATUS LED is red, check the downlink fiber cable for excessive optical loss. Connect the fiber pair to another port. If the second port's LEDs do not illuminate Green/Red, replace the Main Hub. If the second port works, flag the first port as unusable; replace the Main Hub when possible. 	No communication with the Expansion Hub.
	E-HUB/RAU	Off		
	LINK	Green	The Expansion Hub or connected RAU reports a fault Use AdminManager to determine the problem.	The Expansion Hub or one or more RAUs are off-line.
	E-HUB/RAU	Red		

7.4.1.1 Installing Main Hubs in a Multiple Operator System

Installing Main Hubs in a multiple operator system is the same as described in Section 7.4.1 on page 7-13.

We recommend mounting all multiple operator system Main Hubs in the same rack(s), grouped by frequency or wireless carrier. For example, group the Main Hubs for the 800 MHz cellular bands together, and so on.

Connecting to base stations and repeaters is the same as described in Section 7.6 on page 7-35 and Section 7.6.1 on page 7-38.

7.4.2 Installing Expansion Hubs

The Expansion Hub (2U high) can be installed in a standard 19 in. (483 mm) equipment rack or in a wall-mountable equipment rack that is available from ADC. Allow a clearance of 76 mm (3 in.) front and rear and 51 mm (2 in.) sides for air circulation. No top and bottom clearance is required.

Install the Expansion Hub in a horizontal position only.



CAUTION: Install Expansion Hubs in indoor locations only.

✓ Installing an Expansion Hub in a Rack

Consideration:

- The Expansion Hub is shipped with #10-32 mounting screws. Another common rack thread is #12-24. Confirm that the mounting screws match the rack's threads.
- If you want to move the mounting brackets to a mid-mounting position, refer to Installing an Expansion Hub in a Wall-Mounted Rack on page 7-18.

To install the hub in a rack:

1. Insert spring nuts into the rack where needed or use existing threaded holes.
2. Place the Expansion Hub into the rack from the front.
3. Align the flange holes with the spring nuts installed in Step 1.
4. Insert the mounting screws in the appropriate positions in the rack.
5. Tighten the mounting screws.

✓ Installing an Expansion Hub in a Wall-Mounted Rack

Considerations:

- The rack and the Expansion Hub are both 305 mm (12 in.) deep. You must move the rack mounting brackets on the Expansion Hub to the center mounting position to allow for the 76 mm (3 in.) rear clearance that is required.
- The maximum weight the rack can hold is 22.5 kg (50 lbs).

To install the hub in a wall-mounted rack:

1. Attach the equipment rack to the wall using the screws that are provided.
The rack must be positioned so that the Expansion Hub will be in a horizontal position when it is installed.
2. Remove both of the rack mounting brackets from the hub.

3. Reattach each of the rack mounting brackets to the opposite side of the hub from which it came.

Refer to Figure 7-2 for bracket placement.

Figure 7-2 Mounting Bracket Installation

Right Rack Mounting Bracket as installed from the factory.

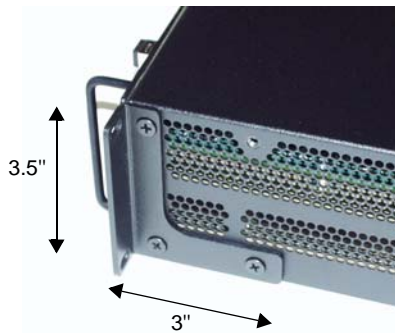

Left Rack Mounting Bracket installed on the right side of the hub.

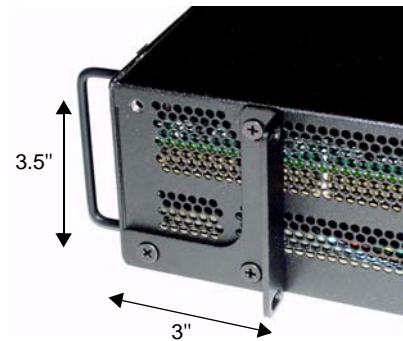

4. Attach the Expansion Hub to the rack.

NOTE: Leave the dust caps on the fiber ports until you are ready to connect the fiber optic cables.

✓ Installing an Optional Cable Manager in the Rack

- Using the screws provided, fasten the cable manager to the rack, immediately above or below the Expansion Hub.

✓ Powering On the Expansion Hub

1. Connect the AC power cord to the Expansion Hub.
2. Plug the power cord into an AC power outlet.
3. Turn on the power to the Expansion Hub and check that all the LED lamps are functioning properly.

Upon power-up, the LEDs blink for five seconds as a visual check that they are functioning. After the five-second test:

- The **POWER** and **UL STATUS** LEDs should be green.
 - If the uplink fiber is not connected within 90 seconds after the test, the **UL STATUS** LED will turn red indicating that there is no communication with the Main Hub.

- The **E-HUB STATUS** and **DL STATUS** LEDs should be red.
- All port LEDs should be off because no RAUs are connected yet.

✓ **Connecting the Fiber Cables to the Expansion Hub**

Considerations:

- Before connecting the fiber cables, confirm that their optical loss does not exceed 3 dB optical budget. RL is less than -60dB.
- If fiber distribution panels are used, confirm that the total optical loss of fiber cable, from the Main Hub through distribution panels and patch cords to the Expansion Hub, does not exceed the optical budget.
- Make sure the fiber cable's connectors are SC/APC (angle-polished). Using any other connector type will result in degraded system performance and may damage the equipment. (You can use an SC/APC pigtail if the fiber cable's connectors are not SC/APC, refer to "Fusion Splicing of Fiber and Pigtail" on page 7-33, or replace the connectors.)

NOTE: Observe all Fiber Port Safety Precautions listed in Section 7.2.3 on page 7-5.

To connect the fiber cables:

The fiber cable is labeled with either **1** or **2**, or is color-coded. For proper connection between the Main Hub ports and the Expansion Hub ports, refer to the numbering or color-coded connections you recorded when installing the Expansion Hub(s).

If the fiber jumper is labeled with **1** or **2**:

1. Connect **1** to **DOWNLINK** on Expansion Hub.

The **DL STATUS** LED should turn green as soon as you connect the fiber. If it does not, there is a downlink problem. Make sure you are connecting the correct cable to the port.

2. Connect **2** to **UPLINK** on Expansion Hub.

The **UL STATUS** LED turns green on the first Main Hub communication. It may take up to 20 seconds to establish communication.

The Expansion Hub's **E-HUB STATUS** LED turns green when the Main Hub sends it the frequency band command.

If the **UL STATUS** and **E-HUB STATUS** LEDs do not turn green/green, check the Main Hub LEDs. Refer to page 7-16, item 2 in Table 7-5.

If the fiber jumper is color-coded (for example, "blue" or "red"):

1. Connect "blue" to **DOWNLINK** on Expansion Hub.

The **DL STATUS** LED should turn green as soon as you connect the fiber. If it does not, there is a downlink problem. Make sure you are connecting the correct cable to the port.

2. Connect “red” to **UPLINK** on Expansion Hub.

The **UL STATUS** LED turns green on the first Main Hub communication. It may take up to 20 seconds to establish communication.

The Expansion Hub’s **E-HUB STATUS** LED turns green when the Main Hub sends it the frequency band command.

If the **UL STATUS** and **E-HUB STATUS** LEDs do not turn green/green, check the Main Hub LEDs. See page 7-16, item 2 in Table 7-5.

Connecting the ScTP Cables

Consideration:

- Verify that the cable has been tested and the test results are recorded.

To test and connect the ScTP cable:

1. Perform cable testing.

Test results are required for the final As-Built Document.

Cable length:

- Minimum: 10 m (33 ft)
- Recommended Maximum: 100 m (328 ft)
- Absolute Maximum: 150 m (492 ft)

If you are using a Cat-5 Extender, the cable length maximum is 170 m (557 feet). (Refer to Section 7.4.5 on page 7-29.)

2. Label both ends of each cable with which RJ-45 port you’re using.
3. Connect the ScTP cables to any available RJ-45 port on the Expansion Hub.
The **LINK** and **RAU** LEDs should be off because the RAU is not connected.
4. Record which cable you are connecting to which port.
This information is required for the As-Built Document.
5. Tie-off cables or use the optional cable manager to avoid damaging the connectors because of cable strain.

7.4.2.1 Troubleshooting Expansion Hub LEDs During Installation

- All Expansion Hub **LINK** and **E-HUB/RAU** LEDs with RAUs connected should indicate Green/Red. This indicates that the RAU is powered on and communication has been established.
- The Expansion Hub **UL STATUS** LED should be Green.

Table 7-6 Troubleshooting Expansion Hub LEDs During Installation

During Installation	LED	State	Action	Impact
1. Expansion Hub power is On and no RAUs are connected	POWER	Off	Check AC power; make sure the Expansion Hub power-on switch is on; replace the Expansion Hub.	The Expansion Hub is not powering on.
	LINK	LEDs are on but didn't blink through all states.	Replace the Expansion Hub.	The Microcontroller is not resetting properly; flash memory corrupted.
	RAU			
	LINK	Red	Port unusable; replace the Expansion Hub when possible.	Current sensor fault; do not use the port.
	RAU	Off		
	UL STATUS	Red, after power-up blink	Replace the Expansion Hub.	The Expansion Hub laser is not operational; no uplink between the Expansion Hub and Main Hub.
	UL STATUS	Red from green after 90 second power-up blink, the cable was connected within 90 seconds of power up.	Check the Main Hub LEDs Refer to page 7-16, item 2 in Table 7-5.	No communication with Main Hub.
DL STATUS	Red	Check the downlink fiber for optical power; verify that the cables are connected to correct ports (that is, uplink/downlink) Check the Main Hub LEDs. Refer to page 7-16, item 2 in Table 7-5.	No downlink between the Expansion Hub and Main Hub.	
2. Expansion Hub power is On and RAUs are connected	LINK	Off	Check the Cat-5E/6 cable. Check the Cat-5 Extender if one is being used.	Power is not getting to the RAU.
	RAU	Off		
	LINK	Red	Test the Cat-5E/6 cable. If the cable tests OK, try another port. If the second port's LEDs are Red/Off, replace the RAU. If the second RAU doesn't work; replace the Expansion Hub. Check the Cat-5 Extender if one is being used.	Power levels to RAU are not correct; communications are not established. If the second port works, flag the first port as unusable; replace EH when possible.
	RAU	Off		
	LINK	Green	Use AdminManager to determine the problem.	RAU is off-line.
	RAU	Red		

7.4.2.2 Installing Expansion Hubs in a Multiple Operator System

Installing Expansion Hubs in a multiple operator system is the same as described in Section 7.4.2 on page 7-18.

If rack-mounting the Expansion Hubs, we recommend mounting all multiple operator system hubs in the same rack(s) or location, grouped by frequency or carrier. For example, group the Expansion Hubs for iDEN together, then the 800 MHz cellular bands, and so on.

7.4.3 Installing RAUs



CAUTION: Install RAUs in indoor locations only. Do not connect an antenna that is installed in an outdoor location to an RAU.

✓ Installing RAUs

Mount all RAUs in the locations marked on the floor plans.

Considerations:

- Install iDEN and 800 MHz Cellular RAUs so that their antennas are apart enough to reduce signal interference between the two bands. Refer to Section , “800 MHz Isolation Requirements,” on page 7-23 for recommended distance between antennas.
- Attach the RAU securely to a stationary object (that is, wall, pole, ceiling tile).
- For proper ventilation:
 - Keep at least 76 mm (3 in.) clearance around the RAU to ensure proper venting. Do not stack RAUs on top of each other.
 - Always mount the RAU with the solid face against the mounting surface.

✓ Installing Passive Antennas

Refer to the manufacturer’s installation instructions to install passive antennas.

Location

Passive antennas are usually installed below the ceiling. If they are installed above the ceiling, the additional loss due to the ceiling material must be considered when estimating the antenna coverage area.

800 MHz Isolation Requirements

When deploying any RF system, give special attention to preventing receiver blocking or desensitization by out-of-band transmitters. Typically, sharp filters in the receiver front-end will reduce the interfering transmitters to tolerable levels. In select

cases, the interferers may occupy a frequency band that is directly adjacent to the receiving band and cannot be adequately rejected by filtering. The only recourse in these situations is to provide sufficient isolation by physically separating the interfering transmitters and receivers.

iDEN occupies spectrum at both 800 MHz and 900 MHz (Tx:806–825/Rx:851–870 and Tx:896–901/Rx:935–940), while the Cellular A and B carriers share a single 800 MHz block (Tx:869–894/Rx:824–849). The combination of these frequency bands, 800/900 MHz iDEN and 800 MHz Cellular, result in uplink (BTS receive) bands that are adjacent to downlink (BTS transmit) bands. Figure 7-3 depicts these nearly contiguous bands, with arrows indicating the interfering downlink and receiving uplink bands.

Figure 7-3 800 MHz Spectrum

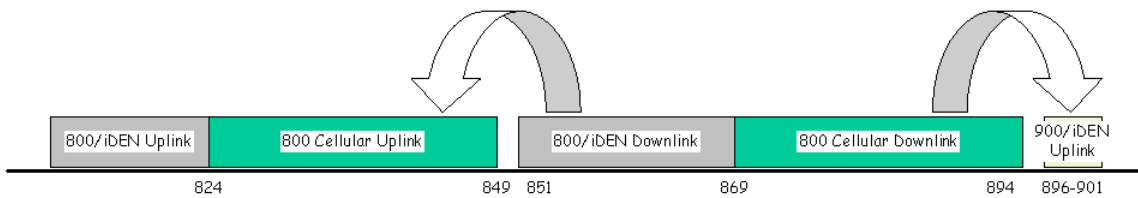

Installation of an in-building distributed antenna system (DAS) to provide coverage for both 800/900 MHz iDEN and 800 MHz Cellular must account for these downlink-to-uplink interference issues and provide adequate isolation.

ADC offers the following guidelines toward achieving the proper amount of isolation when deploying ADC Unison DAS products.

Figure 7-4 Guideline for Unison RAU Antenna Placement

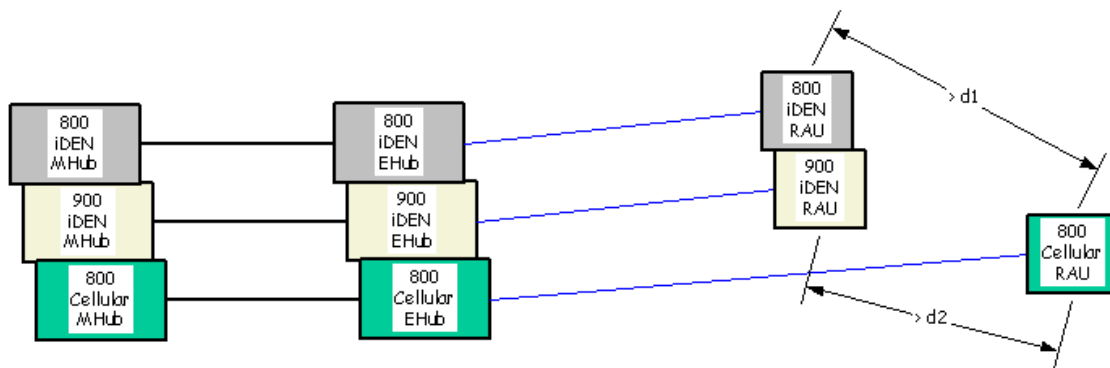

800 MHz iDEN Downlink & 800 MHz Cellular Uplink

A 2 MHz frequency gap (851 – 849 MHz) separates the 800 iDEN downlink and 800 Cellular uplink frequency bands. Because of this narrow spacing, 800 iDEN down-

link intermodulation products may fall within the 800 Cellular uplink band. In addition, 800 iDEN downlink signals near the lower edge of the band at 851 MHz may cause the 800 Cellular uplink automatic level control (ALC) circuitry in the RAU to engage and thereby reduce uplink gain.

To prevent either of these conditions, use the following guidelines:

- In-band 800 iDEN intermodulation products < -90dBm
- Lower frequency 800 iDEN signals < -30dBm for Unison

Given a typical DAS configuration (4 iDEN carriers, omni-directional antennas, line of sight), these guidelines translate to an antenna spacing (d1) of 6–9 meters for Unison.

800 MHz Cellular Downlink & 900 MHz iDEN Uplink

A 2 MHz frequency gap (896 – 894 MHz) separates the 800 Cellular downlink and 900 iDEN uplink frequency bands. Because of this narrow spacing, 800 Cellular downlink intermodulation products may fall within the 900 iDEN uplink band. In addition, 800 Cellular downlink signals near the upper edge of the band at 894 MHz may cause the 900 iDEN uplink ALC to engage and thereby reduce uplink gain.

To prevent either of these conditions, use the following guidelines:

- In-band 800 Cellular intermodulation products < -90dBm
- Upper frequency 800 Cellular signals < -30dBm for Unison

Given a typical DAS configuration (6 CDMA carriers for Unison, omni-directional antennas, line of sight), these guidelines translate to an antenna spacing (d2) of 8-14 meters for Unison.

✓ Connecting the Antenna to the RAU

Connect a passive antenna to the SMA male connector on the RAU using coaxial cable with the least amount of loss possible.



CAUTION: Firmly hand-tighten the SMA female connector – DO NOT over-tighten the connector.

✓ Connecting the ScTP Cable

Consideration:

- Verify that the cable has been tested and the test results are recorded.

To connect the ScTP cable:

- Connect the cable to the RJ-45 female port on the RAU.

Power is supplied by the Expansion Hub. Upon power up, the LEDs blink for two seconds as a visual check that they are functioning. After the two-second test:

- The **LINK** LED should be green indicating that it is receiving power and communications from the Expansion Hub.
- The **ALARM** LED should be red until the Main Hub issues the band command, within about 20 seconds, then it should be green.

7.4.3.1 Troubleshooting RAU LEDs During Installation

- The **LINK** and **ALARM** LEDs should be green, and remain green for longer than 90 seconds. The **ALARM** LED will be red if the system band has not been programmed.

Table 7-7 Troubleshooting RAU LEDs During Installation

During Installation	LED	State	Action	Impact
1. The RAU is connected to the Expansion Hub, which is powered on	LINK	Off	Check the Cat-5E/6 cable.	No power to RAU.
	ALARM	Off		
	LINK	Green	<ul style="list-style-type: none"> • Check the Cat-5E/6 cable. • Check Expansion Hub LEDs Refer to page 7-22, item 2 in Table 7-6. • Use AdminManager to determine the problem. 	RAU is off-line.
	ALARM	Red		
	LINK	Red from green, after the cables are connected for 60 seconds	<ul style="list-style-type: none"> • Check the Cat-5E/6 cable • Check the Expansion Hub LEDs Refer to page 7-22, item 2 in Table 7-6. • Use AdminManager to determine the problem. 	No communications between the RAU and the Expansion Hub.
	ALARM	Red		

7.4.3.2 Installing RAUs in a Multiple Operator System

When installing both iDEN and Cellular systems in parallel, either as dual-band or multiple operator systems, you must take special provision to assure that the individual RAUs do not interfere with each other.

The 800 MHz Cellular and iDEN RAU's antennas must be separated by 6 to 8 meters (20 to 26 feet) to assure that the iDEN downlink signals do not interfere with the Cellular uplink signals.

7.4.4 Installing a Dual-Band RAU Configuration

7.4.4.1 Using Dual-Band Diplexer



CAUTION: Install RAUs and diplexers in indoor locations only. Do not connect an antenna that is installed in an outdoor location.

Dual band RAU configuration consists of:

- 1 higher band RAU
- 1 lower band RAU
- 1 Dual-Band Diplexer (PN #DIPX1-1)
- 2 coaxial cables, 3 ft. long (PN #4005-3)

✓ Installing RAUs in a Dual Band System

Use a Dual-Band Diplexer to combine the output of a low-band RAU and a high-band RAU to a single dual band antenna.

Considerations:

- The Diplexer will have a high loss when it is connected incorrectly. When using it with the Unison system, incorrect connections may trigger the Antenna Disconnect alarm.
- When using the Dual-Band Diplexer, the Unison system Antenna Disconnect alarm can detect if the cable is disconnected or cut **between the RAU and the Diplexer**. This alarm, however, cannot detect it if the cable is disconnected or cut between the Diplexer and the antenna.

Figure 7-5 shows the RAU configuration in a dual band system. It consists of two RAUs, one for upper band and one for lower band, a diplexer and two 3 ft. coaxial cables.

Figure 7-5 Dual Band RAU Configuration

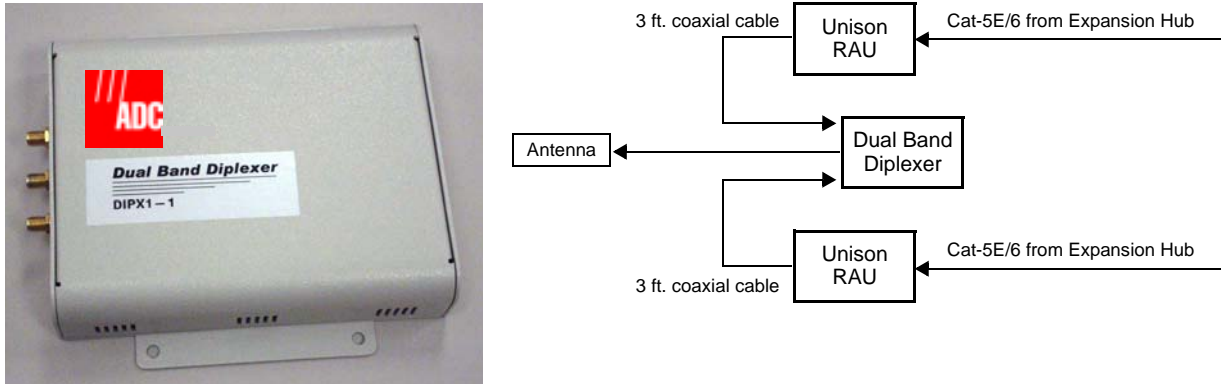

To connect the RAUs and Dual Band Diplexer for a dual band system:

1. Verify that the Unison system is powered on.
2. Attach the Diplexer to a stable surface (that is, wall, ceiling tile, pole).
Do not mount the Diplexer on top of an RAU.
3. Attach the two RAUs to a stable surface within 2.5 ft. of the Diplexer (do not stack the RAUs on top of each other).
4. Connect the Cat-5E/6 cable coming from the Unison lower band system (that is, system band below 1 GHZ) to the correct RAU.
The **LINK** LED on the RAU should be green.
5. Connect the Cat-5E/6 cable coming from the Unison upper band system (that is, system band above 1 GHZ) to the correct RAU.
The **LINK** LED on the RAU should be green.
6. Connect a coaxial cable to the antenna ports on each of the RAUs.
The recommended coaxial cable (PN 4005-3) is 3 ft. long.
7. Connect the coaxial cable coming from the Unison lower band system (that is, system band below 1 GHZ) to the Diplexer port labeled “LOWER BAND.”
8. Connect the coaxial cable coming from the Unison upper band system (that is, system band above 1 GHZ) to the Diplexer port labeled “UPPER BAND.”
9. Connect a coaxial cable from the dual band antenna to the Diplexer port labeled “ANTENNA.”



✓ Connecting the Antenna to the Dual Band Diplexer

Connect a single passive antenna to the Dual Band Diplexer’s “Antenna” SMA connector using coaxial cable with the least amount of loss possible.



CAUTION: Firmly hand-tighten the SMA female connector – DO NOT over-tighten the connector.

7.4.4.2 Using Dual-Port Antenna

Connect both RAUs directly to a dual-port, dual-band antenna.

Figure 7-6 Dual-Port Antenna Configuration

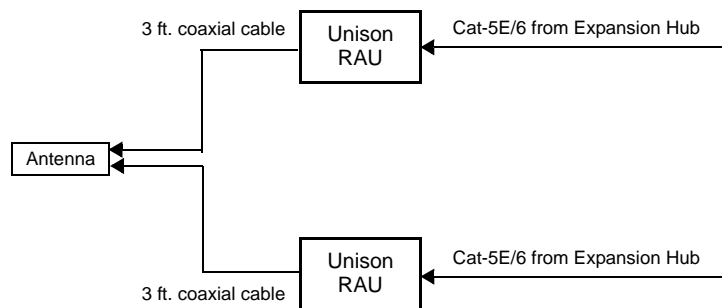

7.4.5 Using a Cat-5 Extender

The Cat-5 Extender (PN #UNS-EX170-1)** increases the maximum length of the Cat-5E/6 ScTP cable run that connects the Expansion Hub to the RAU from 100 meters to 170 meters. The minimum cable length between the Hub and Extender is 90 meters and the minimum length between the Extender and RAU is 20 meters. Beyond the minimum lengths, an additional 60 meters of cable, maximum of 170 meters total, can be inserted before or after the Extender.

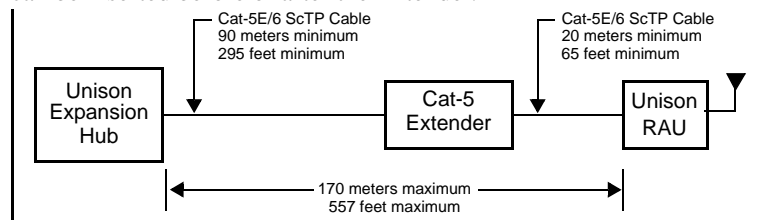

** For Japan, refer to the separate addendum - *Japan Specification Document*.

Table 7-8 shows the minimum and maximum cable lengths that must be met:

Table 7-8 Maximum/Minimum Cable Lengths

Min. Cat-5E/6 Cable Length from Unison Hub to Extender	Min. Cat-5E/6 Cable Length from Extender to RAU	Max. Cat-5E/6 Cable Length from Unison Hub to RAU
90 meters (295 feet)	20 meters (65 feet)	170 meters (557 feet)

✓ Installing a Cat-5 Extender



Power is transported from the Unison system to the Cat-5 Extender using the Cat-5E/6 cable. No power comes from the RAU. Although the bottom LED on the Cat-5 Extender lights green when the cable is connected to either port, it is only providing power when it is correctly inserted into the port labeled “TO UNISON HUB.” (Note that the top LED is disabled and will not light.)

1. Verify that the Unison system is powered on and that the Cat-5E/6 cable is connected into the appropriate port.
2. At the Cat-5 Extender site, plug the Cat-5E/6 cable coming from the Unison system into the Extender port labeled “TO UNISON HUB.” The Extender’s bottom LED should light green if the Expansion Hub is powered on.
3. Connect the Cat-5E/6 cable going to the RAU into the other port, which is labeled “TO RAU.”

CAUTION: Ensure that the cables are connected to the correct ports. Otherwise, you may damage the RAU.

If the bottom LED does not light after you have verified that the Cat-5E/6 cable from the Unison system is plugged into the port called “TO UNISON HUB,” then the Unison system may not be powered on, the Cat-5E/6 cable may be cut/broken, or there is a problem with the Extender. Verify that the Unison system is connected to AC power and the power switch is in the ON position.

7.4.6 Configuring the System

✓ Configuring the Installed System

Considerations:

- The AdminManager PC/laptop is connected to the Main Hub.
- The AdminManager software is started.
- All system components are installed and powered on.

To configure an installed system:

1. Turn on the PC and start AdminManager.

The AdminManager main window appears.

2. Disable alarm filtering. Use View, Preferences and select “Enable faults, warnings, and status messages.”
3. Select Settings from the Connection menu item.

The Connection Settings dialog box appears.

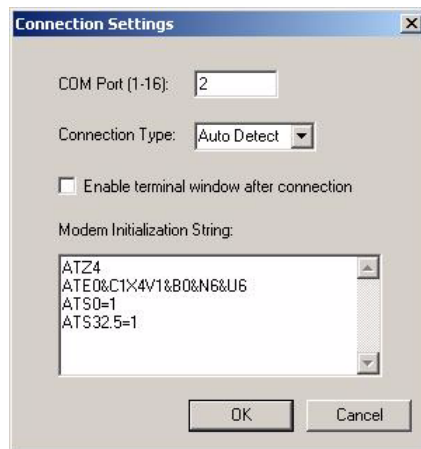

4. Enter the COM Port in the text box.
5. Select the Connection Type from the drop-down menu. ADC recommends using Auto Detect if unsure.
6. Click OK.
7. Press the Enter key to initiate the connection.

When the connection is made, a hierarchical system tree is displayed in the left pane of the window. The following icons are displayed indicated that the frequency band is not programmed:



If the system tree is not displayed, press F5 key to refresh the tree display.

8. Right-click on the Main Hub icon and select Install/Configure System.

The System Configuration window appears.

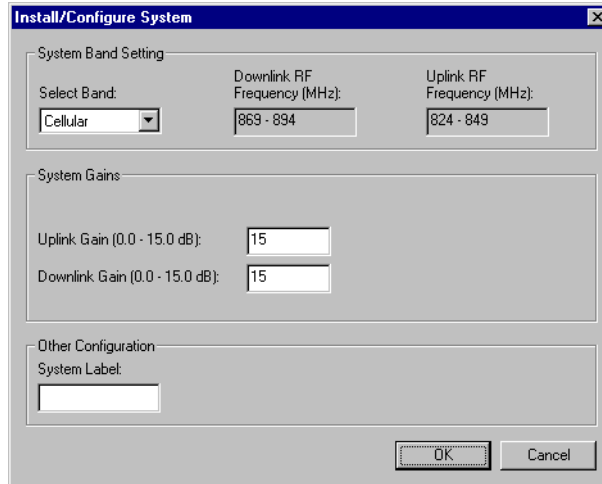

9. Select the operating band from the Select Band pull down menu.
The operating band must match the band of the RAUs that are used in the system.
10. Change the System Gain in the text boxes, if desired.
The default is 0 dB for both the uplink and downlink.
11. Change the System Label, if desired.
The default is “Unison.”
12. Click OK.

During configuration, which can take several minutes for a fully-loaded system (that is, 32 RAUs), all disconnect status are cleared; the frequency band, gain, and system label are set; logs are cleared; the system test is performed; and finally the status tree is refreshed. The icons should be:



Indicating that the band is correctly set.



Indicating that communications are OK.



Indicating that communications are OK.

If there are problems, the icons are different and a message is displayed in the Messages pane.

The Unison system should now be operational. Using a mobile phone, walk your site and test the signal strength.

NOTE: Refer to Section 9 for troubleshooting.

7.5 Splicing Fiber Optic Cable

The fiber cable must have SC/APC connectors for the entire run. If it does not, you can splice a pigtail, which has SC/APC connectors, to the fiber cable.

ADC offers two pigtails: one for single-mode fiber (PN 4013SCAPC-3) and one for multi-mode fiber (PN 4012SCAPC-3).

ADC recommends fusion splices because they have the lowest splice loss and return loss. Mechanical splices have higher losses and higher back reflection than fusion splices and are not recommended.

7.5.1 Fusion Splices

Using a fusion splicer involves fusing together two butted and cleaved ends of fiber. The fusion splicer aligns the fibers and maintains alignment during the fusion process. Fusion splices have very low loss (typically less than 0.05 dB) and very low back reflection (return loss). Fusion splices should be organized in a splice tray designed to store and protect the splices.

✓ Fusion Splicing of Fiber and Pigtail

Before you begin, make sure the fusion splicer is set to the proper mode (that is, single- or multi-mode).

To fusion splice the fiber optic cable to the SC/APC pigtail: Option A

1. Secure both the fiber cable and the SC/APC pigtail in a splice tray that is installed immediately adjacent to the Hub.
2. Prepare the fiber end by cutting back the polyethylene jacket, the kevlar or fiber-glass strength members, the extruded coating, and the buffer coating in order to expose the “bare fiber” – cladding plus core.
Ensure that sufficient slack is maintained in order to be able to reach the fusion splicer.
3. Clean the unclad fiber core using isopropyl alcohol and lint-free wipes.
4. Cleave the unclad fiber to the length prescribed by the fusion splicer’s specification sheets.
5. Repeat steps 2 through 4 for the SC/APC pigtail.
6. Pass the splice sleeve onto the fiber strand.
7. Position both fiber ends in the fusion splicer and complete splice in accordance with the fusion splicer’s operation instructions.
8. Ensure that the estimated loss for the splice as measured by the fusion splicer is 0.10 dB or better.
9. Slide the fusion splicing sleeve over the point of the fusion splice.
10. Place the sleeve and fused fiber into the fusion splicer’s heater.

11. Allow time for the splice sleeve to cure.
12. Return fiber splice to the splice tray, store the sleeve in a splice holder within the tray, and store excess cable length in accordance with the tray manufacture's directions.

After successfully testing the fiber, plug the SC/APC pigtail into the proper optical port on the Hub.

To fusion splice the fiber optic cable to the SC/APC pigtail: Option B

1. Secure both the fiber cable and the SC/APC pigtail in a splice tray portion of a fiber distribution panel.
2. Prepare the fiber end by cutting back the polyethylene jacket, the kevlar or fiber-glass strength members, the extruded coating, and the buffer coating in order to expose the "bare fiber" – cladding plus core.

Ensure that sufficient slack is maintained in order to be able to reach the fusion splicer.

3. Clean the unclad fiber core using isopropyl alcohol and lint-free wipes.
4. Cleave the unclad fiber to the length prescribed by the fusion splicer's specification sheets.
5. Repeat steps 2 through 4 for the SC/APC pigtail.
6. Pass the splice sleeve onto the fiber strand.
7. Position both fiber ends in the fusion splicer and complete splice in accordance with the fusion splicer's operation instructions.
8. Ensure that the estimated loss for the splice as measured by the fusion splicer is 0.10 dB or better.
9. Slide the fusion splicing sleeve over the point of the fusion splice.
10. Place the sleeve and fused fiber into the fusion splicer's heater.
11. Allow time for the splice sleeve to cure.
12. Return fiber splice to the splice tray, store the sleeve in a splice holder within the tray, and store excess cable length in accordance with the tray manufacture's directions.
13. After successfully testing the fiber cable, plug the SC/APC pigtail into the back side of the SC/APC bulkhead in the Fiber Distribution Panel.

Install a SC/APC patch cord between the front side of the SC/APC bulkhead and the proper optical port on the Hub.

7.6 Interfacing a Main Hub to a Base Station or a Roof-top Antenna



WARNING: Only ADC personnel or ADC-authorized installation personnel should connect the Unison Main Hub to a base station or repeater. Exceeding the maximum input power could cause failure of the Main Hub (refer to Section 6.1 on page 6-3 for maximum power specifications). If the maximum composite power is too high, attenuation is required.

NOTE: The **UPLINK** and **DOWNLINK** ports cannot handle a DC power feed from a base station. If DC power is present, a DC block must be used or the main hub may be damaged.

✓ Connecting a Main Hub to an In-Building Base Station

Connecting a Simplex Base Station to a Main Hub:

1. Connect an N-male to N-male coaxial cable to the transmit simplex connector on the base station.
2. Connect the other end of the N-male to N-male coaxial cable to the **DOWNLINK** connector on the Main Hub.
3. Connect an N-male to N-male coaxial cable to the receive simplex connector on the base station.
4. Connect the other end of the N-male to N-male coaxial cable to the **UPLINK** connector on the Main Hub.

Figure 7-7 Simplex Base Station to a Main Hub

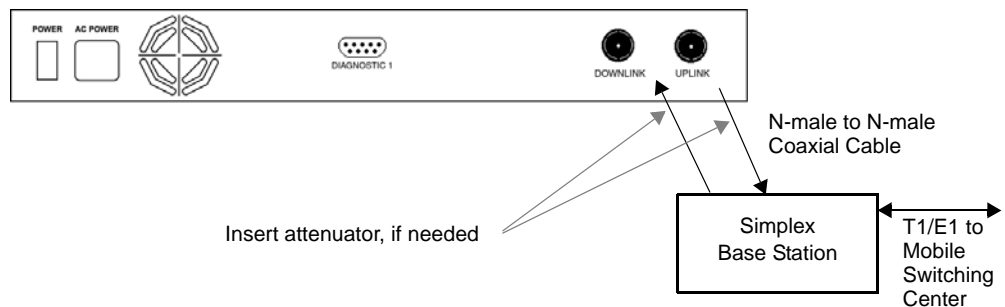

Connecting a Duplex Base Station to a Main Hub:

When connecting to a duplex base station, use a circulator between it and the Main Hub.

You can insert attenuators between the circulator and Main Hub as needed; refer to Section 6.6.1 on page 6-40 for more information.

1. Connect an N-male to N-male coaxial cable to the duplex connector on the base station.
2. Connect the other N-male connector to a circulator.
3. Connect an N-male to N-male coaxial cable to the **DOWNLINK** connector on the Main Hub.
4. Connect the other end of the N-male coaxial cable to the transmit connector on the circulator.
5. Connect an N-male to N-male coaxial cable to the **UPLINK** connector on the Main Hub.
6. Connect the other end of the N-male coaxial cable to the receive connector on the circulator.

Figure 7-8 Duplex Base Station to a Main Hub

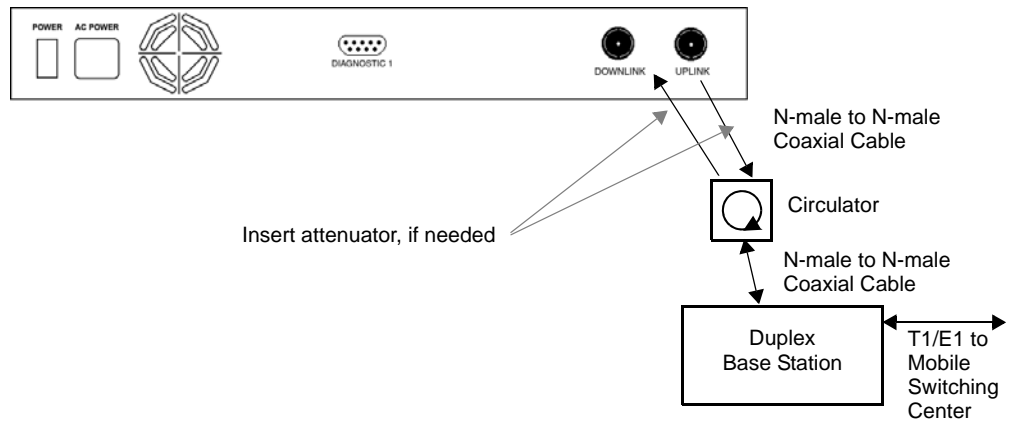

✓ Connecting a Main Hub to Multiple Base Stations

You can use power combiner/splitters to connect a Main Hub to multiple base stations, as shown in Figure 7-9.

Figure 7-9 Connecting a Main Hub to Multiple Base Stations

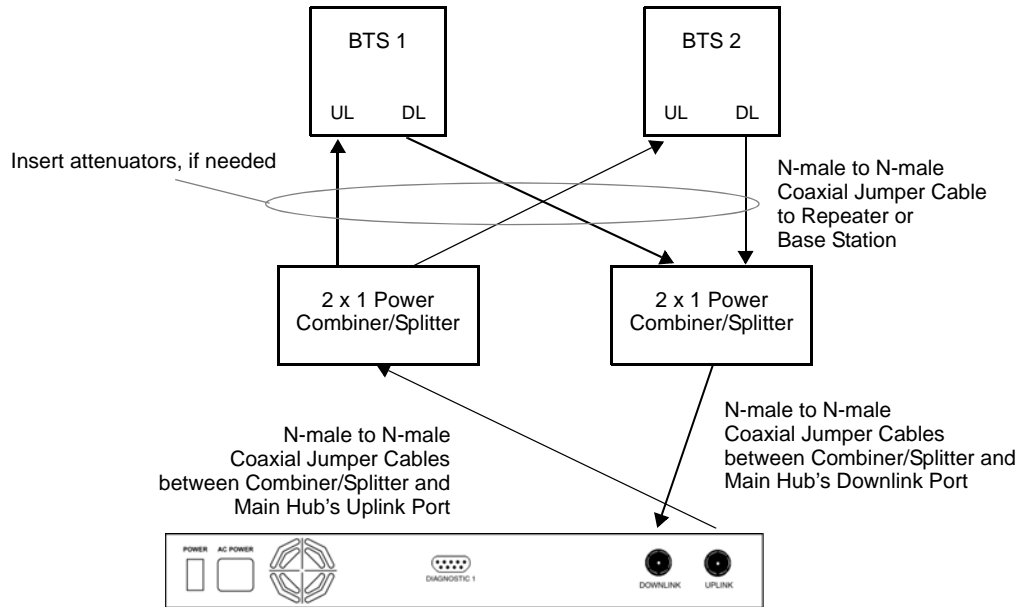

✓ Connecting a Main Hub to a Roof-top Antenna

ADC recommends that you use a lightning arrestor or surge protector in a roof-top antenna configuration. Insert the lightning arrestor or surge protector between the roof-top antenna and the repeater that is connected to the Main Hub.

1. Connect an N-male to N-male coaxial cable to the roof-top antenna.
2. Connect the other end of the N-male to N-male coaxial cable to the grounded surge suppressor.
3. Connect an N-male to N-male coaxial cable to the grounded surge suppressor.
4. Connect the other end of the N-male to N-male coaxial cable to the repeater.
5. Connect an N-male to N-male coaxial cable to the repeater.
6. Connect the other end of the N-male to N-male coaxial cable to the circulator 1 connector.
7. Connect an N-male to N-male coaxial cable to the circulator 2 connector.
8. Connect the other end of the N-male to N-male coaxial cable to the **DOWNLINK** connector on the Main Hub.

Attenuation may be required to achieve the desired RF output at the RAU.

9. Connect an N-male to N-male coaxial cable to the circulator **3** connector.
10. Connect the other end of the N-male to N-male coaxial cable to the **UPLINK** connector on the Main Hub.

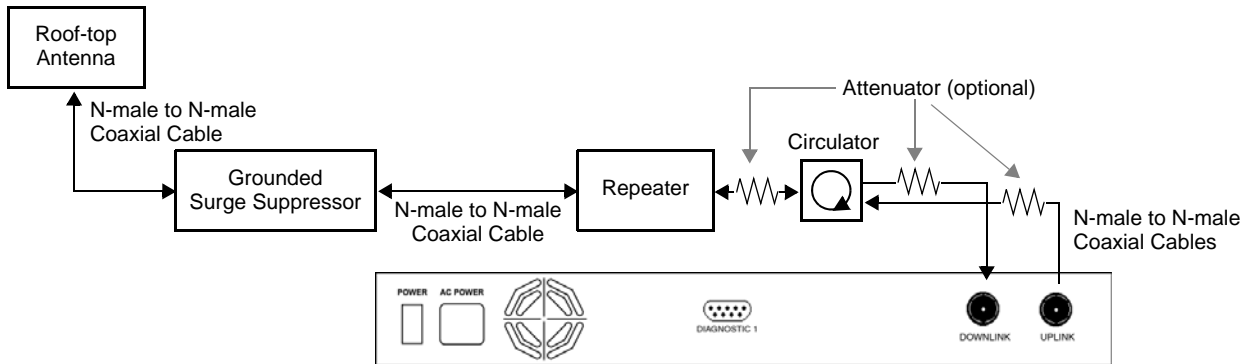

7.6.1 Connecting Multiple Main Hubs

You can use power combiner/splitters as splitters to connect multiple Main Hubs in order to increase the total number of RAUs in a system. You can also use power combiner/splitters to combine base station channels in order to increase the number of RF carriers the system transports.

✓ Connecting Multiple Main Hubs to a Simplex Repeater or Base Station

Considerations:

- 2 hybrid power combiner/splitters; one for uplink and one for downlink (2x1 for two Main Hubs, 3x1 for three, 4x1 for four, etc.)
- 1 N-male to N-male coaxial jumper cable between each power combiner/splitter and the base station
- 2 N-male to N-male coaxial jumper cables between each power combiner/splitter and each Main Hub

Procedure:

1. Connect the power combiner/splitters to the repeater or base station using N-male to N-male coaxial jumper cables:
 - a. From the first power combiner/splitter to the repeater or base station
 - b. From the second power combiner/splitter to the repeater or base station
2. Connect the power combiner/splitters to the Main Hubs:
 - a. From the first Main Hub's **UPLINK** port to the first power combiner/splitter

- b. From the first Main Hub's **DOWNLINK** port to the second power combiner/splitter
 - c. From the second Main Hub's **UPLINK** port to the first power combiner/splitter
 - d. From the second Main Hub's **DOWNLINK** port to the second power combiner/splitter
3. Check Main Hub LEDs.

After connecting and powering on the Main Hub, check all LEDs to ensure that the system is operating properly.

NOTE: Use a 50 ohm terminator on any unused power combiner/splitter ports.

Figure 7-10 shows connecting two Main Hubs to a simplex repeater or base station. Connecting two Main Hubs increases the total number of supportable RAUs from 32 to 64. Two Main Hubs support up to 8 Expansion Hubs which in turn support up to 64 RAUs.

Figure 7-10 Connecting Two Main Hubs to a Simplex Repeater or Base Station

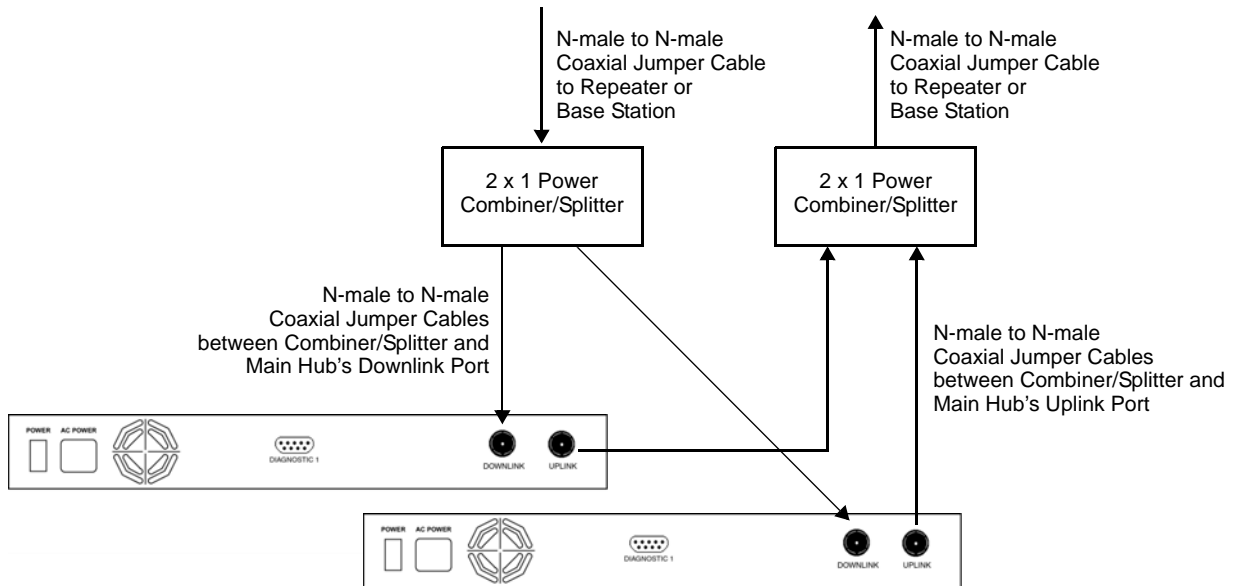

✓ Connecting Multiple Main Hubs to a Duplex Repeater or Base Station

Considerations:

- 2 hybrid power combiner/splitters; one for uplink and one for downlink (2x1 for two Main Hubs, 3x1 for three, 4x1 for four, and so on.)
- 2 N-male to N-male coaxial jumper cables to connect each Main Hub to the power combiner/splitters
- 1 circulator
- 1 N-male to N-male coaxial jumper cable between each circulator and the repeater or base station
- 1 N-male to N-male coaxial jumper cable between each circulator and power combiner/splitter

Procedure:

1. Connect the Circulator to the power combiner/splitters and to the repeater or base station using one N-male to N-male coaxial jumper cable.
2. Connect each power combiner/splitter to the circulator using one N-male to N-male coaxial jumper cable.
3. Connect the power combiner/splitter to the Main Hubs:
 - a. From the first Main Hub's **UPLINK** port to the first power combiner/splitter
 - b. From the first Main Hub's **DOWNLINK** port to the second power combiner/splitter
 - c. From the second Main Hub's **UPLINK** port to the first power combiner/splitter
 - d. From the second Main Hub's **DOWNLINK** port to the second power combiner/splitter

4. Check Main Hub LEDs.

After connecting and powering on the Main Hub, check all LEDs to ensure that the system is operating properly.

NOTE: Use a 50 ohm terminator on any unused power combiner/splitter ports.

To connect two Main Hubs to a duplex repeater or base station, use one circulator and one more coaxial jumper cable, as shown in Figure 7-11.

Figure 7-11 Connecting Two Main Hubs to a Duplex Repeater or Base Station

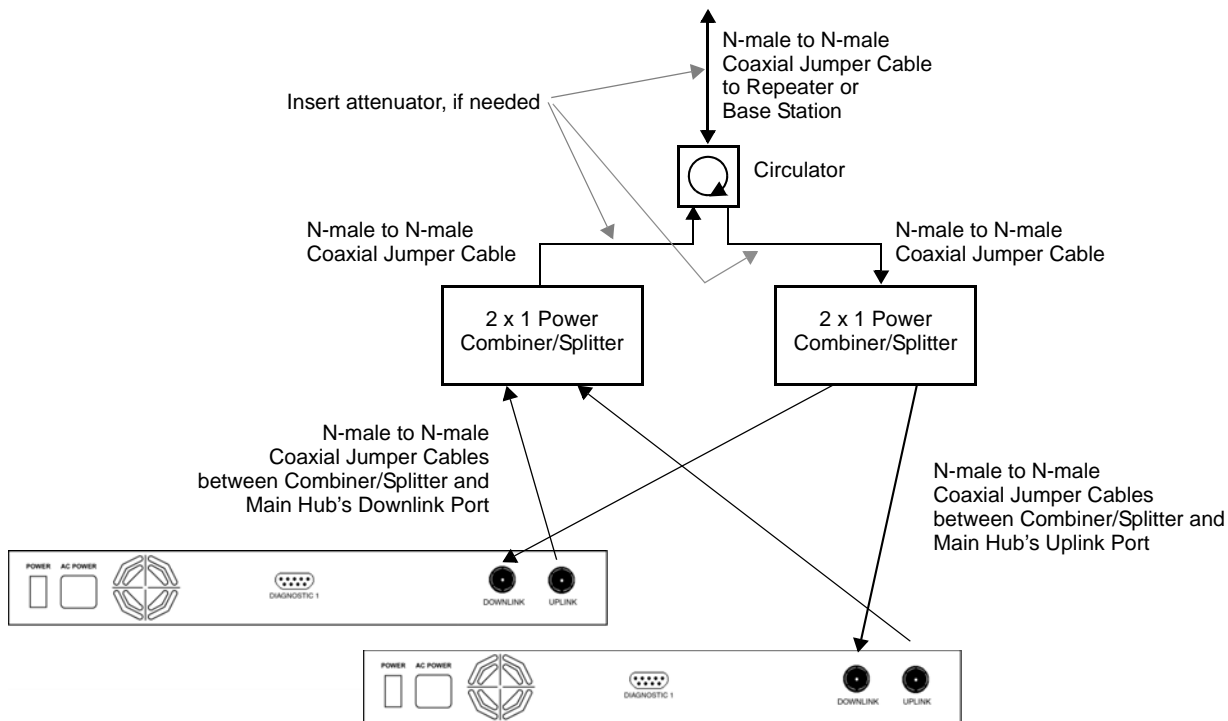

7.7 Connecting Contact Alarms to a Unison System

The Unison Main Hub can generate (source) two contact alarms as well as sense an external contact alarm.

- **Alarm Source (refer to Section 7.7.1 on page 7-43)**

The Main Hub has two alarm contacts, fault (major) and warning (minor). These contact are normally-closed (NC) and will open when an internal alarm is detected.

NOTE: The contact can be changed to normally-open (NO) with Admin-Manager. This is not recommended as no alarm would be sent if power to the Main Hub fails.

- Fault is activated when any faults or disconnects are detected.
- Warning is activated when any warning conditions are detected except lockout or when the end-to-end system test is not valid.
- **Alarm Sense (refer to Section 7.7.2 on page 7-46)**

The Main Hub can monitor an external alarm contact. The port can be configured for normally-open (NO) or normally-closed (NC) contacts. The interface expects a set of floating contacts, and an external voltage source is not required for this interface. Use AdminManager or OpsConsole to monitor the port status.

Table 7-9 lists the alarm types, equipment that Unison is connected to, cable(s) used, and the faults (major and/or minor) that are detected.

Table 7-9 Alarm Types

Alarm Type	Unison connected to	Cable(s) Used	Alarms Detected
Source	FlexWave Focus	5-port Alarm Daisy-Chain Cable	Faults
Source	BTS	5-port Alarm Daisy-Chain Cable In addition, a custom daisy-chain cable-to-BTS interface cable is required. Make this interface cable to the desired length and with the appropriate pin placement.	Faults and Warnings
Sense	LGCell	5-port Alarm Daisy-Chain Cable and the Alarm Sense Adapter Cable	Faults

NOTE: The 5-port Alarm Daisy-Chain cable is for normally closed (NC) contacts.

NOTE: LGCell and FlexWave Focus support only faults (major alarms).

Do not mix LGCell and Unison Main Hubs in the same daisy-chain. You can daisy-chain multiple LGCell Main Hubs together and use the Alarm Sense Adapter Cable to connect the chain to a Unison Main Hub, which will act as an alarm sensor.

7.7.1 Alarm Source

Unison always acts an alarm source, no matter what type of equipment you are connecting to. Refer to Section 7.7.2 on page 7-46 if you want Unison to sense LGCell contact closures or other external alarms.

Using FlexWave Focus to Monitor Unison

When you connect FlexWave Focus to Unison, the Unison Main Hub is the output of the alarms (alarm source) and Focus is the input (alarm sense), as shown in the following figure. Focus supports only faults (major alarms).

Figure 7-12 Connecting FlexWave to Unison

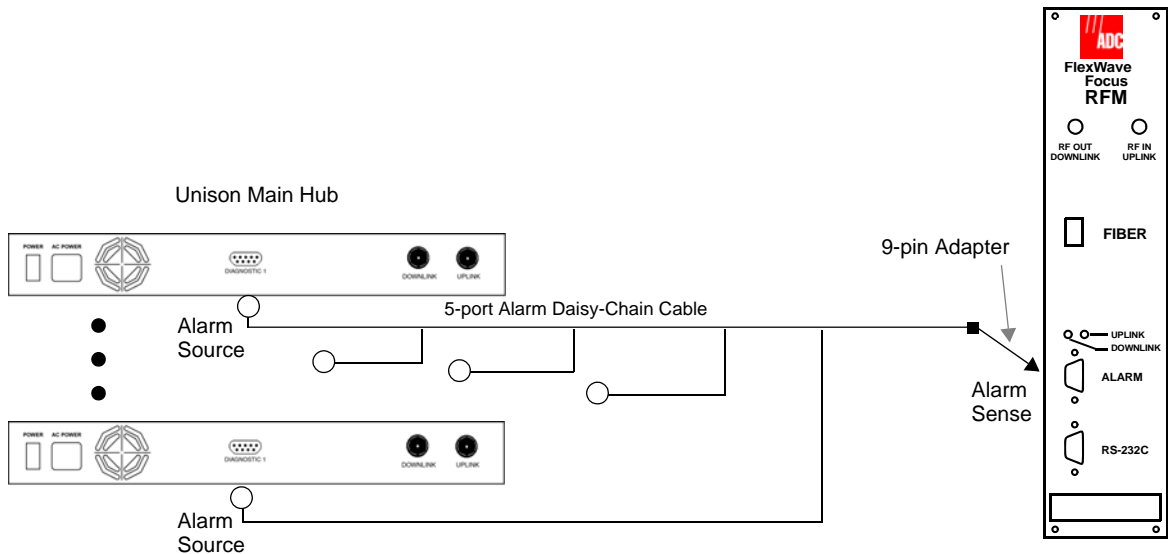

Using a Base Station to Monitor Unison

When you connect a BTS to Unison, the Unison Main Hub is the output (alarm source) and the BTS is the input (alarm sense), as shown in Figure 7-13. An interface cable is required between the daisy-chain cable and the BTS. Because BTS alarm interface pinouts and Unison-to-BTS distances vary, this cable often is custom and wired on-site. Refer to “Main Hub Rear Panel Connectors” on page 3-8 for Alarm Contact details (Normally Closed).

Figure 7-13 Using a BTS to Monitor Unison

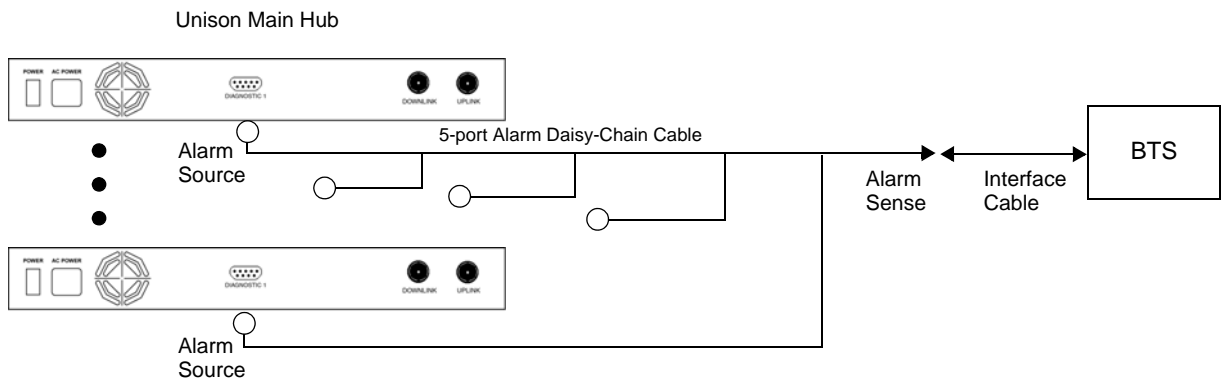

NOTE: For normally open contacts, the fault and warning contacts need to be wired in parallel with other Main Hubs.

NOTE: ADC does not recommend using normally open contacts.

Using a Base Station and *OpsConsole* to Monitor Unison

In order to take full advantage of Unison's OA&M capabilities use ADC *OpsConsole* software in addition to a BTS to monitor the system, as shown in Figure 7-14.

Figure 7-14 Using a BTS and *OpsConsole* to Monitor Unison

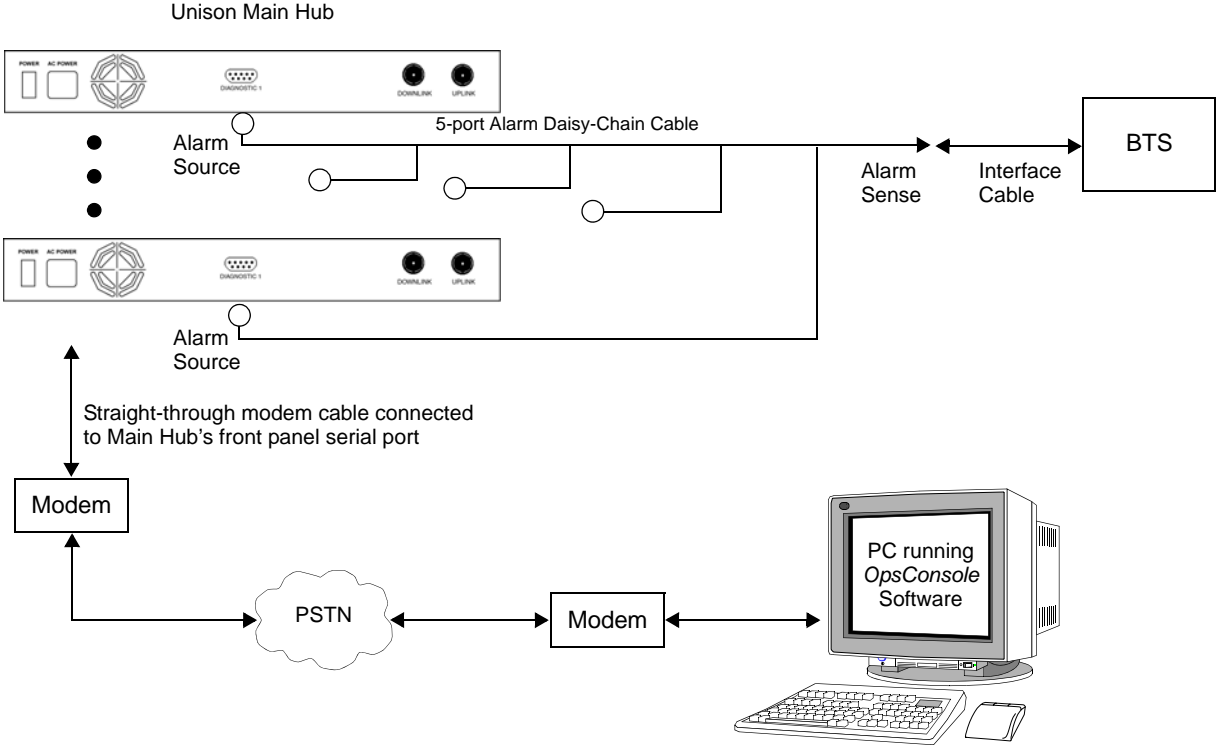

7.7.2 Alarm Sense

Use AdminManager to enable the Unison system for “alarm sense” when connecting to the contact closure of LGCell Main Hubs or other external alarms (refer to Set Contact Sense Properties in the *AdminManager User Manual*).

Using Unison to Monitor LGCells

When you connect LGCell to Unison, the Unison Main Hub is the input of the alarms (alarm sense) and the LGCell is the output (alarm source), as shown in Figure 7-15.

Figure 7-15 Connecting LGCell to Unison

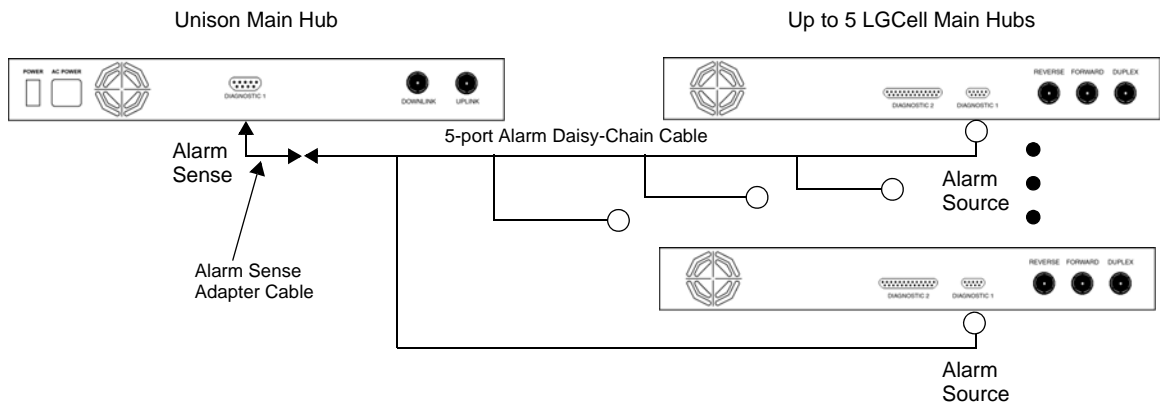

LGCell supports only faults (major alarms). You must use the Alarm Sense Adapter Cable (refer to page 7-50) to interface the daisy-chain cable to Unison. The adapter cable is required because it translates the LGCell fault pinout to the sense input pins on the Unison Main Hub.

Figure 7-16 Alarm Sense Contacts

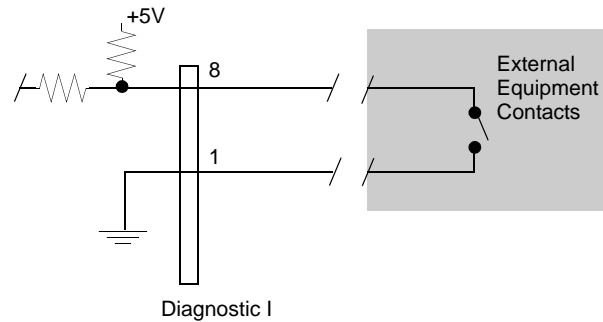

7.7.2.1 Expansion Hub Alarm Sense (UNS-EH-2 only)

The Expansion Hub can sense three external contact closure alarms. These contact closure inputs were designed for monitoring an Uninterruptible Power Supply (UPS), but could monitor any external event that provides the proper input level.

These contact closure inputs are user programmable for enable/disable and normally open/normally closed definition. The factory default is disabled/normally closed for all three contacts. Use AdminManager to enable and set the appropriate NO/NC state.

If a contact event alarm is detected, the Expansion Hub reports the alarm condition to the Main Hub as a warning condition. The Expansion Hub front panel LEDs do not indicate a contact event alarm. Use AdminManager or OpsConsole to determine the exact alarm event.

The expansion Hub supplies 5V. If the contact is open at the external device, the Micro reads 5V. When the contact is closed at the external device-the micro reads 0V or Ground.

Table 7-10 Pin Connections

DB9 Pin #	Connection	Signal Name
1	N/C	N/A
2	+5V through a 10K Ohm resistor. Input to micro controller	ALARM3
3	+5V through a 10K Ohm resistor. Input to micro controller	ALARM1
4	GND	N/A
5	+5V through a 10K Ohm resistor. Input to micro controller	ALARM2
6	N/C	N/A
7	N/C	N/A
8	GND	N/A
9	GND	N/A

Table 7-11 Input Electrical Characteristics

Parameter	Description	Specification
Rmin	Loop resistance for "OFF" condition	> 20k Ohm
Rmax	Loop resistance for "ON" condition	< 2k Ohm
T on Max	Max Turn-on Time	5 Second
T off Max	Max Turn-Off Time	5 Second

- The micro controller sees a high or 5V for an open condition. The loop resistance must be greater than 20K Ohm to guarantee the micro sees 3.5V or greater.
- The micro controller sees low or 0V for a closed condition. The loop resistance must be greater than 2K Ohm to guarantee the micro sees 1V or less.
- You may have to determine a time on and off for the connection so that the alarm is not intermittent.
- Firmware has a five second hysteresis to ensure the micro does not capture intermittent contact closures.

Table 7-12 Output Electrical Characteristics

Parameter	Description	Specification
I Max	Continuous Load Current	550uA
V Max	DC volts out	5 V + 5%
T on Max	Max Turn-on Time	5 Seconds
T off Max	Max Turn-Off Time	5 Seconds

I max is $5V/10K = 500uA$. +/- uA due to R and V tolerances.

Vmax is 5V+5% from power supply spec.

7.7.3 Alarm Cables

5-port Alarm Daisy-Chain Cable

Figure 7-17 shows the 5-port Alarm Daisy-Chain Cable (PN 4024-3), which supports fault and warning conditions (that is, major and minor alarms).

Figure 7-17 5-port Alarm Daisy-Chain Cable

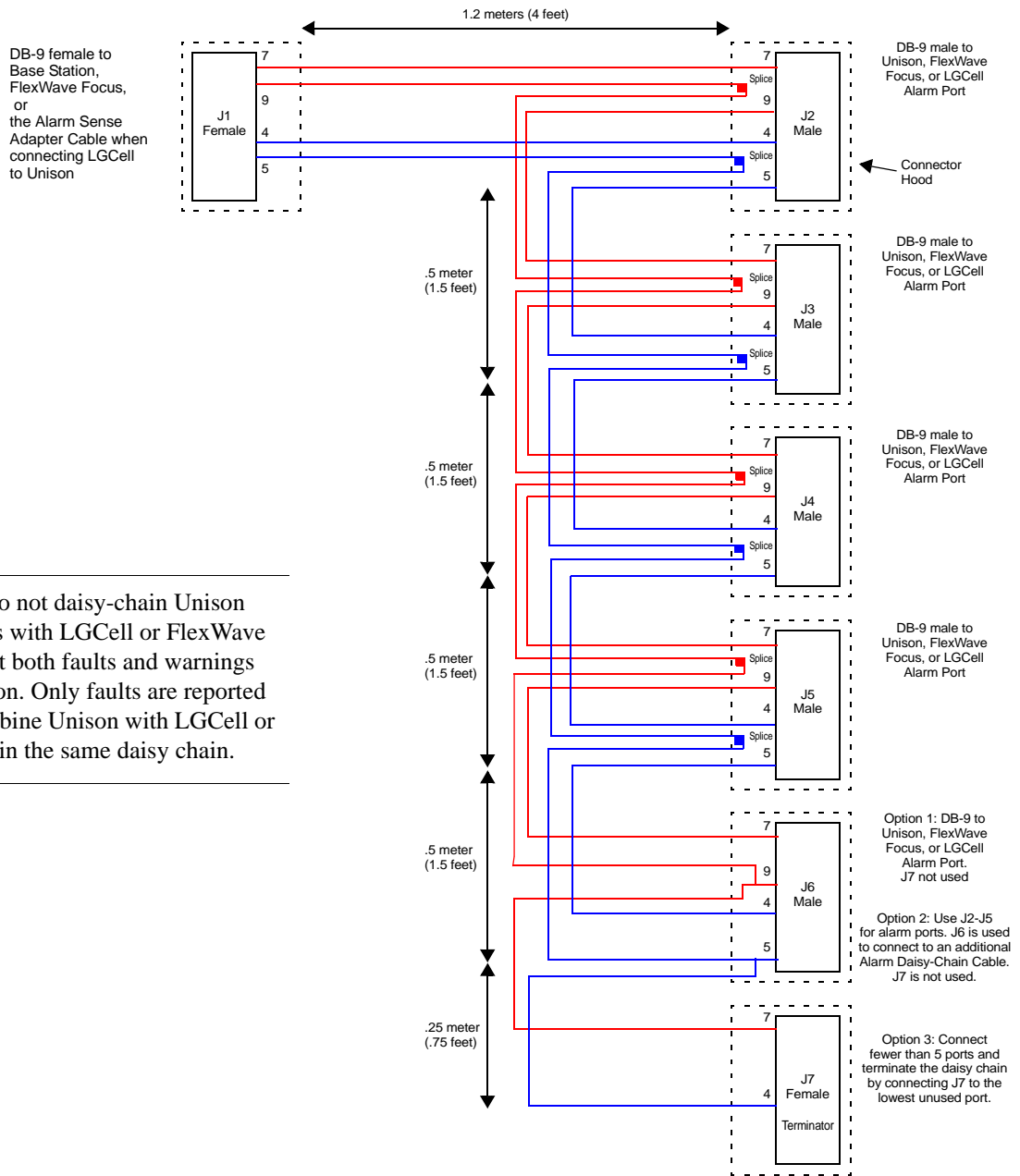

NOTE: Do not daisy-chain Unison Main Hubs with LGCell or FlexWave if you want both faults and warnings from Unison. Only faults are reported if you combine Unison with LGCell or FlexWave in the same daisy chain.

Alarm Sense Adapter Cable

The alarm sense adapter cable (PN 4025-1) translates the LGCell fault pinout to the sense input pins on the Unison Main Hub. You must use this adapter cable, as illustrated in Figure 7-18, with the 5-port Alarm Daisy-Chain Cable when connecting LGCell to Unison.

Figure 7-18 Alarm Sense Adapter Cable

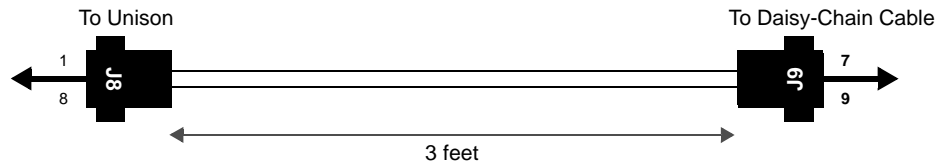

7.8 Alarm Monitoring Connectivity Options

The following connectivity options are described here:

- Section 7.8.1 Direct Connection 7-51
- Section 7.8.2 Modem Connection 7-52
- Section 7.8.3 RS-232 Port Expander Connection 7-53
- Section 7.8.4 POTS Line Sharing Switch Connection 7-54
- Section 7.8.5 Ethernet and ENET/RS-232 Serial Hub Connection 7-55
- Section 7.8.6 Network Interface Unit (NIU) 7-56

Note that the only accessory that is available through ADC is the DB-9 to DB-9 null modem cable, which is provided with AdminManager.

7.8.1 Direct Connection

In this configuration, the AdminManager or OpsConsole PC connects directly to the RS-232 serial port on the Main Hub's front panel using a null modem cable.

Figure 7-19 OA&M Direct Connection

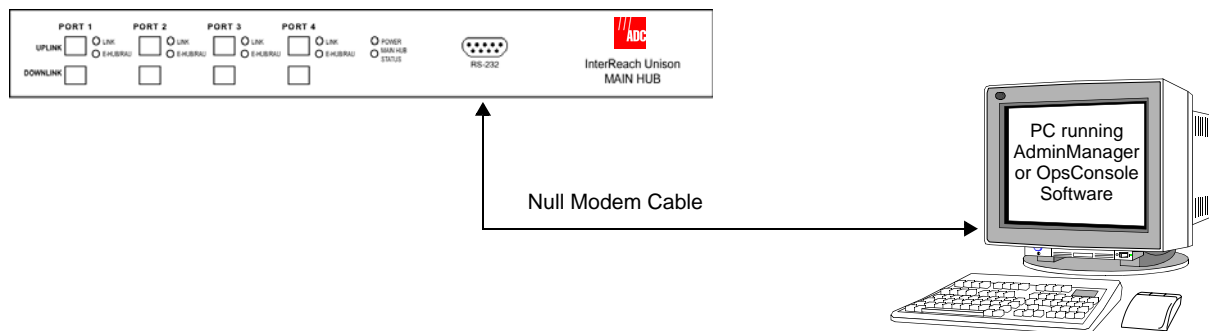

NOTE: The null modem cable must support full hardware handshaking. Refer to Appendix A.5 on page A-4 for cable wiring information.

7.8.2 Modem Connection

In this configuration, the PC and the Main Hub connect to modems and communicate using a standard dial-up telephone connection.

Figure 7-20 OA&M Modem Connection

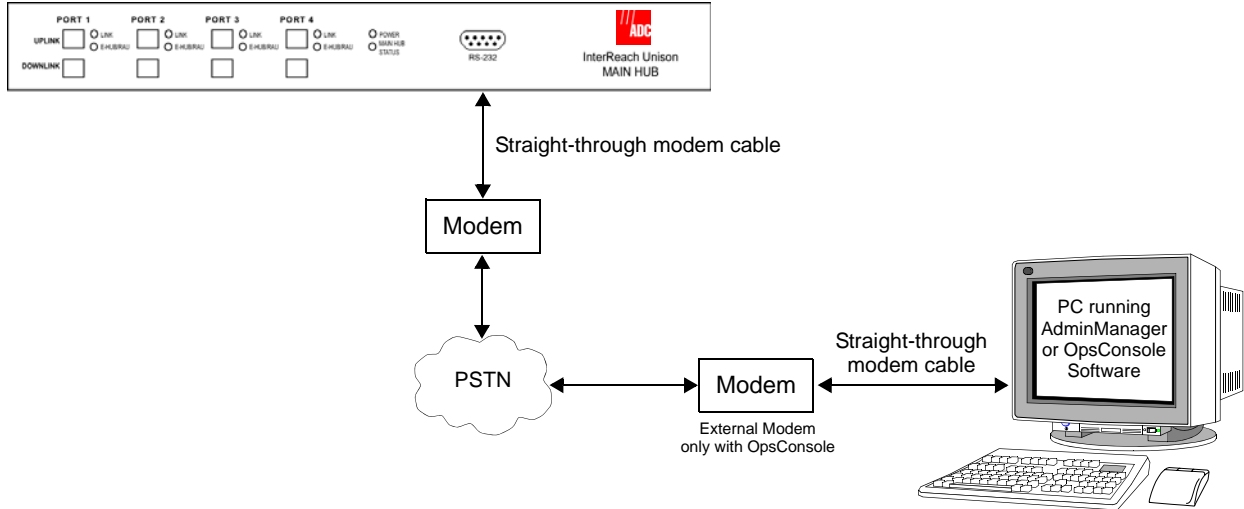

NOTE: Refer to Appendix A.4 on page A-3 for the modem cable wiring information.

7.8.3 RS-232 Port Expander Connection

In this configuration a port expander is used to allow the connection of multiple devices to a single PC serial port. Testing was performed with an Equinox SST-16P Multiport Board. A DB-25 male to DB-9 female modem cable must be made to connect the connector panel to the Main Hub (refer to Appendix A.6 on page A-5). Or, you can use a DB-25 male/DB-9 male adapter with a DB-9 female to DB-9 female null modem cable.

Figure 7-21 OA&M Connection using an RS-232 Port Expander

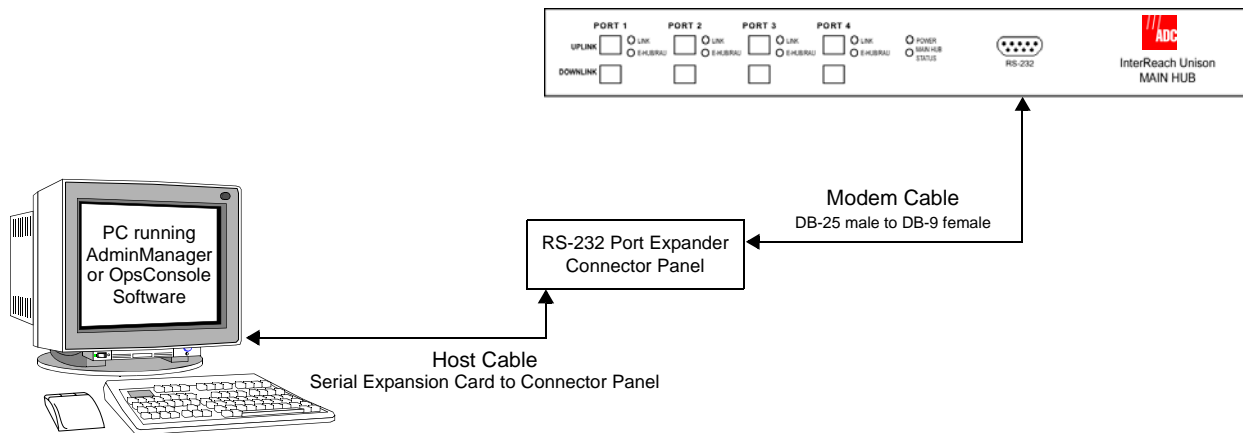

NOTE: Refer to Appendix A.6 on page A-5 for the modem cable wiring information.

7.8.4 POTS Line Sharing Switch Connection

Using a line sharing switch you can connect up to four modems to a single telephone line. Testing was performed with a Teltone Line Sharing Switch, model number M-394-B-01.

Figure 7-22 OA&M Connection using a POTS Line Sharing Switch

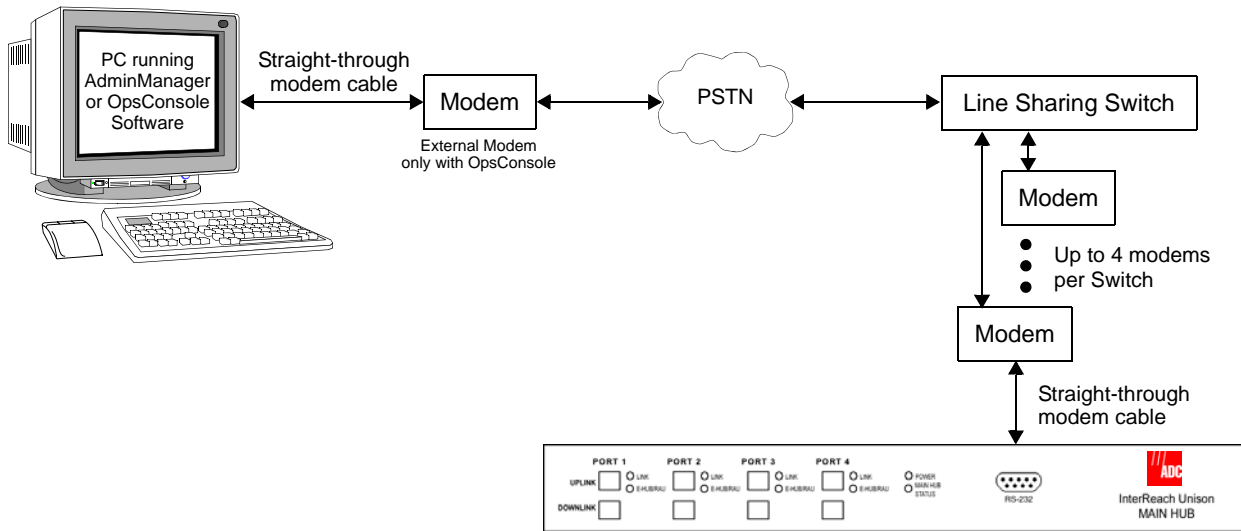

Up to 16 modems can be monitored using a single telephone line by cascading line sharing switches, as shown in Figure 7-23.

Figure 7-23 Cascading Line Sharing Switches

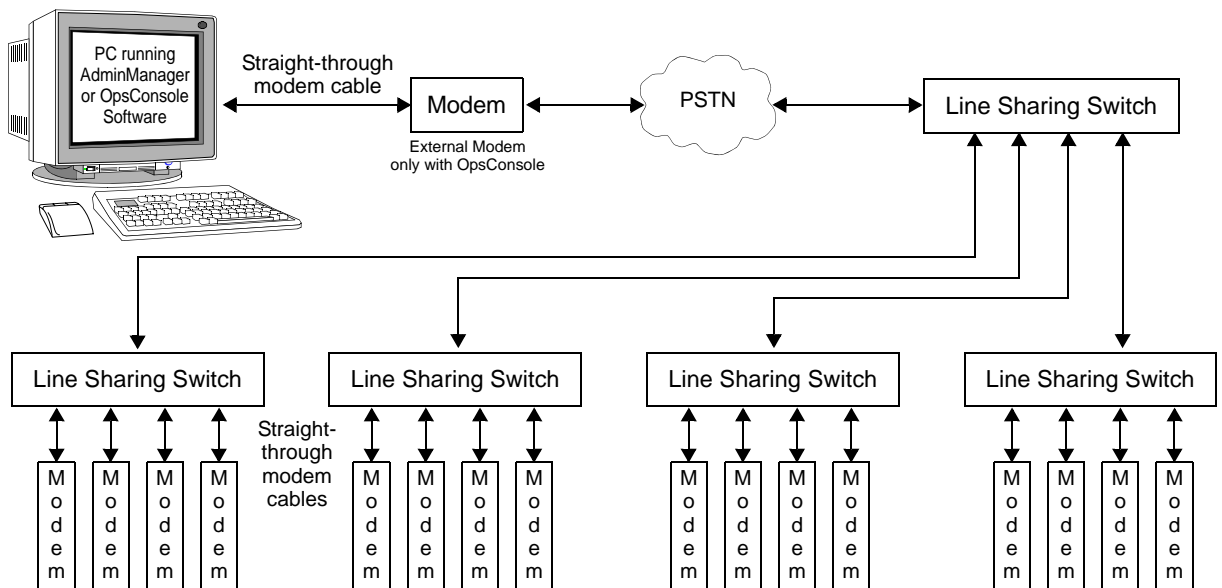

7.8.5 Ethernet and ENET/RS-232 Serial Hub Connection

You can use an Ethernet-to-RS-232 serial hub or converter box to communicate between the PC and Unison. Testing was performed with an Equinox SST Ethernet Serial Provider.

Figure 7-24 OA&M Connection using Ethernet and ENET/232 Serial Hub

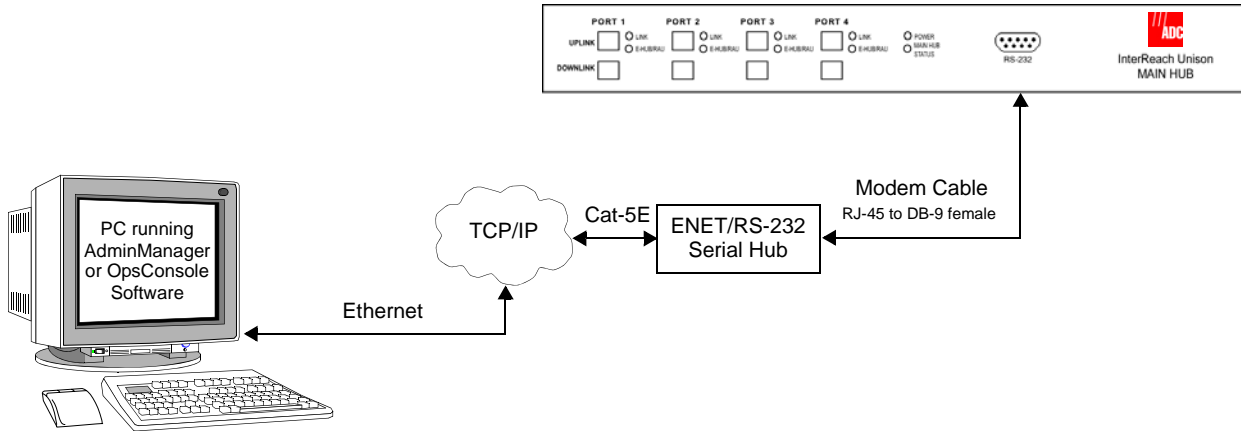

7.8.6 Network Interface Unit (NIU)

Faults and warnings can also be diagnosed with SNMP using the NIU. The NIU supports complete interactions with Unison system:

- Gets, Sets, and Traps/Notification

The NIU enables access to multiple ADC systems at a site as follows:

- NIU-4P-NM-1 (Up to four Unison systems)
- NIU-12P-NM-1 (Up to twelve Unison systems)

The ADC NIU includes a MIB for integrating into the Network Management System (NMS) and supports SNMPv1 and SNMPv2c.

Figure 7-25 Network Interface Unit (NIU) Configuration Options

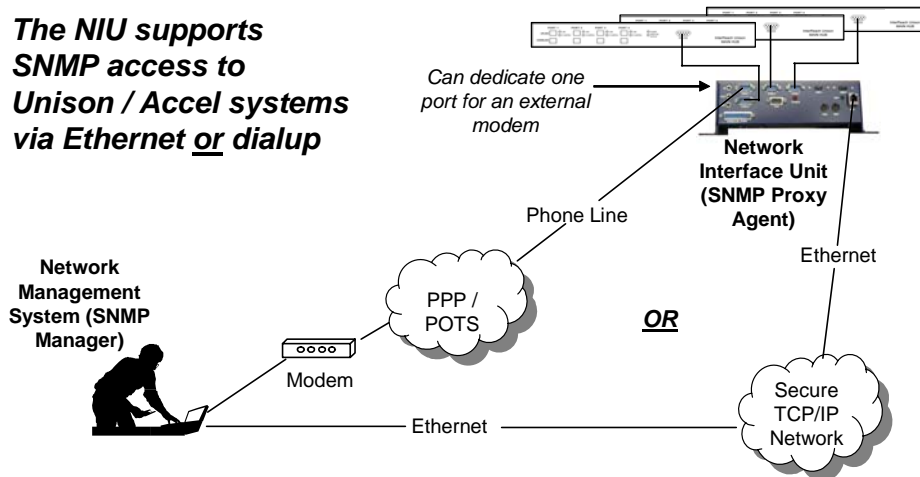

- 1 NIU-12P-NM-1 supports up to 12 Unison/Accel systems
NIU-4P-NM-1 supports up to 4 Unison/Accel systems (not exandable)

Figure 7-26 Multiple Unison Systems Monitored by a Single Network Management System

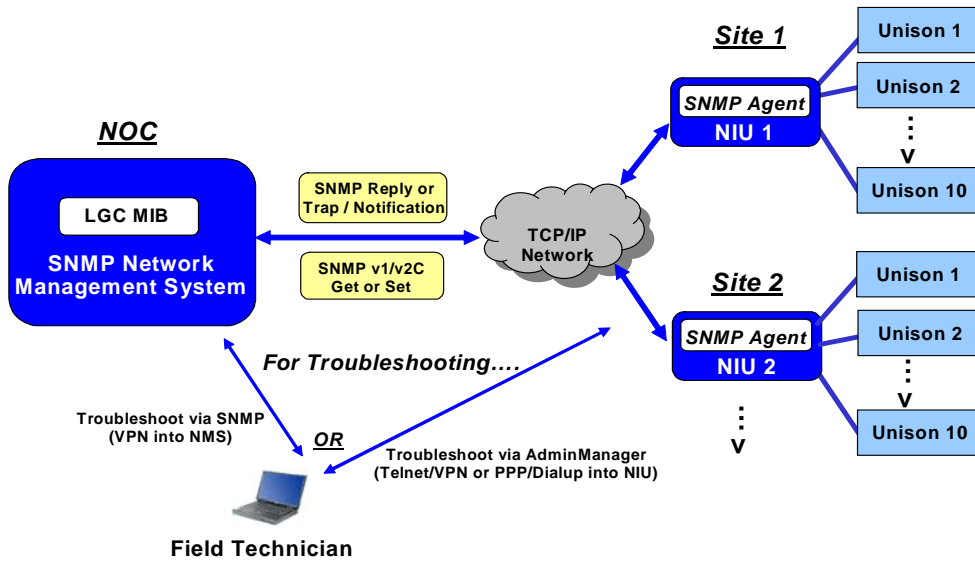

This page is intentionally left blank.

Replacing Unison Components

8.1 Replacing an RAU

Be aware that the new RAU must be the same band as the one you are replacing. If you replace an RAU with one that is of the wrong band, it will not work.

The Main Hub automatically checks the band of a replaced RAU. There is no need to issue commands directly from the Main Hub. Therefore, as long as the RAU is of the correct band, the system will operate properly.

Replacing an RAU

1. Using AdminManager, right-click on the RAU's icon and select Advanced RAU Settings from the Unit Commands menu item.

The Advanced RAU Settings window is displayed. Write down the settings so you can set the new RAU with the same settings.

2. Click CANCEL to close the window.
3. Verify that the new RAU is of the same frequency band as the one replaced.
4. Disconnect the Cat-5/5E/6 cable and antenna cable from the unit to be replaced.
5. Install the new RAU.
6. Connect the antenna cable and then the Cat-5/5E/6 cable to the new RAU.
7. Right-click on the RAU icon and select Advanced RAU Settings from the Unit Commands menu item.

The Advanced RAU Settings window is displayed.

8. Set the DL/UL attenuation as the old RAU was programmed and click OK.

✓ Perform System Test

When convenient, perform System Test to optimize performance.

During System Test, the entire system is temporarily off-line and no RF is being transmitted. For a fully loaded system (one Main Hub, four Expansion Hubs, and 32 RAUs), it can take up to 1.5 minutes to complete the test.

✓ Checking the RAU's LEDs

1. The RAU's **LINK** and **ALARM** LEDs should blink (green/red) on power up.
 - If the LEDs do not blink on power up, replace the RAU.
2. After several seconds both LEDs should change to green, which indicates that the unit has been successfully replaced, there is communication with the Expansion Hub, and the RAU band is correct.
 - a. If the **LINK** LED remains green and the **ALARM** LED remains red, verify that the RAU model is correct for the intended frequency band.
 - Disconnect the cable and then reconnect it once; doing this more than once will not change the result.
 - b. If both LEDs still don't change to green, use the AdminManager to determine the exact nature of the fault and see a recommendation of how to correct it.
 - c. If both LEDs turn red (after 90 seconds), the Expansion Hub has terminated communications.

8.2 Replacing an Expansion Hub

✓ Replacing an Expansion Hub

1. Turn off the power to the Expansion Hub.
2. Disconnect all Cat-5/5E/6 cables, both fiber cables, and the AC power cord.
3. Replace the Expansion Hub with a new one.
4. Connect the AC power cord, all Cat-5/5E/6 cables, and both fiber cables – remembering to clean and correctly connect the uplink and downlink fiber.
5. Turn on the power to the Expansion Hub.

✓ AdminManager Tasks

- The Main Hub automatically issues the band setting.
- When convenient, use AdminManager to perform System Test in order to optimize performance.

During System Test, the entire system is temporarily off-line and no RF is being transmitted. For a fully loaded system (one Main Hub, four Expansion Hubs, and 32 RAUs), it can take up to 1.5 minutes to complete the test.

✓ Checking the Expansion Hub's LEDs

- The LEDs should blink through all states on power up.
 - If the LEDs do not blink on power up, replace the Expansion Hub.
 - If the LEDs do not illuminate at all, make sure the AC power cable is connected.
- The **UL STATUS** and **DL STATUS** LEDs should be green.
- The **E-HUB STATUS** and **POWER** LEDs should be green.
- For each RJ-45 port that has an RAU connected:
 - The **LINK** LEDs should be green.
 - The **RAU** LEDs should be green.

It can take several seconds for each Cat-5/5E/6 connection for the LEDs to display properly.

NOTE: Refer to Section 9 for troubleshooting using the LEDs.

8.3 Replacing a Main Hub

You must record the system configuration settings from the old Main Hub's memory before replacing the unit (refer to Step 1 below). You will program the new Main Hub with this information. If the Main Hub is programmed incorrectly, the system will not work. If the Main Hub is not functioning, get the configuration settings from the As-Built Document that was created as part of the original installation.

✓ Replacing a Main Hub

1. Using AdminManager, right-click on the Hub's icon and select Get Parameters from the System Commands menu item.

The system's configuration is displayed in the Messages pane.

2. Turn off the power to the Main Hub.
3. Disconnect all cables and the AC power cord.
4. Replace the Hub with a new one.
5. Connect the AC power cord and all cables.
6. Connect the null modem cable to the PC and then to the Hub's front panel DB-9 serial connector.
7. Start the AdminManager software.
8. Turn on the power to the Hub.
9. Observe the LEDs after turning on the power.

All the LEDs will blink during the initial power up sequence. If the Hub has been programmed with a band, all LEDs should turn green after the power on sequence is complete. Power up sequence takes between 1 and 2 minutes depending on the number of RAUs.

✓ Configure the New Main Hub

1. Right-click the Main Hub's icon and select Install/Configure System from the menu.

The System Configuration window is displayed. Write down the settings so you can set the new Main Hub with the same settings.

2. Select the operating band from the Select Band drop down menu.
3. Enter the uplink and downlink gain in the text boxes.
4. Enter the system label.
5. Click OK.
6. Set the Callback Number and Contact Sense Properties if they are used.
7. Set the current date/time of day.

Checking the Main Hub's LEDs

- The LEDs should blink through a 5-second test on power up.
 - If the LEDs do not blink on power up, replace the Main Hub.
- ✓
 - If the LEDs do not illuminate at all, make sure the AC power cable is connected.
- For each fiber optic port that has a connected Expansion Hub, which has been programmed with a band:
 - The **LINK** LED should be green.
 - The **E-HUB/RAU** LED should be green indicating that all downstream units are functioning
- Refer to Section 9.3, "Troubleshooting," on page 9-3 for more LED states.

NOTE: If there is communication between the Main Hub and the Expansion Hubs, use the AdminManager to isolate system problems.

This page is intentionally left blank.

Maintenance, Troubleshooting, and Technical Assistance

There are no user-serviceable parts in any of the Unison components. Faulty or failed components are fully replaceable through ADC.

Address	2540 Junction Avenue San Jose, California 95134-1902 USA
Phone	1-408-952-2400
Fax	1-408-952-2410
Help Hot Line	1-800-530-9960 (U.S. only) +1-408-952-2400 (International)
Web Address	http://www.adc.com
e-mail	service@lgcwireless.com

9.1 Service

There are no user-serviceable parts in the InterReach Unison system. All units should be replaced and returned to the factory for service if needed.

9.2 Maintenance

Keep the fiber ports clean and free of dust. No other periodic maintenance of the Unison equipment is required.

To clean the fiber ports:

You can clean the Hub's fiber ports using canned compressed air or isopropyl alcohol and cotton swabs.

Considerations:

- If you use compressed air:
 - The air must be free of dust, water, and oil.
 - Hold the can level during use.
- If using isopropyl alcohol and foam-tipped swab:
 - Use only 98% pure or more alcohol.

Procedure using compressed air:

1. Remove the connector's dust cap.
2. Spray the compressed air away from the unit for a few seconds to clean out the nozzle and then blow dust particles out of each fiber port.

Procedure using isopropyl alcohol:

1. Remove the connector's dust cap.
2. Dip a 2.5mm lint-free, foam-tipped swab in isopropyl alcohol and slowly insert the tip into the connector.
3. Gently twist the swab to clean the connector.
4. Insert a dry swab to dry the connector.

Additionally, you can use compressed air after the alcohol has completely evaporated.

9.3 Troubleshooting

NOTE: Unison has no user-serviceable parts. Faulty or failed units are fully replaceable through ADC.

Sources of potential problems include:

- Faulty cabling/connector
 - Malfunction of one or more Unison components
 - Antenna, base station, or repeater problem
 - External RF interface
 - Tripped circuit breaker
 - Using a Null modem cable that does not support full hardware handshaking when using AdminManager
-

NOTE: Faulty cabling is the cause of a vast majority of problems. All Cat-5/5E/6 cable should be tested to TIA/EIA 568-A specifications. The RAU can be damaged if the cable is not wired correctly.

You must use AdminManager or OpsConsole for troubleshooting the system, use the LEDs only as backup or for confirmation. However, if there are communication problems within the system, the LEDs may provide additional information that is not available using AdminManager.

If you cannot determine the cause of a problem after following the recommended procedures, call the ADC customer help hot line:

1-800-530-9960 (U.S. only)
 +1-408-952-2400 (International)

Or, email us at service@lgcwireless.com.

Please provide the following information:

- Serial number of the unit
- Description of the problem
- Using AdminManager 2.04 or higher, execute the **Tools → Get Service Information** command. Save and email this file to us.
- What is the length of the Cat-5/5E/6 cable? Is it screened?
- Status of the LEDs on the unit
- Was the unit power cycled?

9.3.1 Troubleshooting using AdminManager

Use AdminManager software to determine the current faults and warnings for all of the units in the system. To troubleshoot, start with the Main Hub's faults AND warnings, then proceed to each of the Expansion Hubs, finishing with each of the RAUs.



NOTE: AdminManager v2.04 or higher displays events (faults, warnings, or status messages) depending on your view preference. To change your view preference, refer to Section 3.4.2, "View Preference," on page 3-10.

NOTE: Faults usually impact service; warnings may impact service; status does not generally impact service, but contains important information that you should not ignore.

System Troubleshooting

Get All Current Faults & Warnings (or Get Faults; or Get Current Faults, Warnings, and Status Messages). This gives the current status of the system depending on view preferences, and should be used to determine if there is more than one fault/warning in the system. Point to the top most icon or the Main Hub in the hierarchical tree, and right click to see the Pull down menu. Select: SYSTEM COMMANDS/GET FAULTS (OR GET CURRENT FAULTS AND WARNINGS; OR GET CURRENT FAULTS, WARNINGS, AND STATUS MESSAGES).

NOTE: System commands **always** take longer to execute than component commands.

NOTE: This RAU icon  indicates there is fault on the RAU. This icon  indicates a disconnected device. You cannot request status on a disconnected device.

Component Troubleshooting

- If a device displays as an fault icon, right click on the icon, and select UNIT COMMANDS/ GET CURRENT FAULTS. If a device displays as a warning or information icon, right click on the icon, and select UNIT COMMANDS/ GET CURRENT WARNINGS AND STATUS MESSAGES.

9.3.1.1 Troubleshooting Recommendations

- Some things that can be done, depending on the device fault or warning include:
 - a. Hardware faults on Expansion Hub.
 - Try swapping fiber with another Expansion Hub at the Main Hub.
 - Try cleaning the fiber and the fiber ports with alcohol foam tip swab and compressed air. See Section , “To clean the fiber ports:,” on page 9-2.
 - Power cycle the Expansion Hub.
 - b. Issue a CLEAR ALL DISCONNECTS at the Main Hub.
 - c. Power cycle the Main Hub.
 - d. RAU hardware faults. Try swapping the Cat-5/5E/6 at Expansion Hub with a good Cat-5/5E/6 cable.
 - e. If there is an RF14 Fault and the Cat-5/5E/6 run has an Extender, check that it is installed correctly. See Section , “Installing a Cat-5 Extender,” on page 7-30.
 - f. Try isolating the system components:
 - Check to see if the whole system is effected or a portion of the system.
 - If the whole system is effected, disconnect the DAS system from the RF source and see if the RF source is working.
 - Continue to isolate by disabling portions of the system. Use the UNIT COMMANDS/SET OUT-OF-SERVICE and SET IN-SERVICE.

9.3.1.2 Fault Indications

Once all of the units are powered on and the cable connections are made, the faults from each unit can be requested using AdminManager. Start with the Main Hub and work downstream.

NOTE: AdminManager v2.04 or higher displays events (faults, warnings, or status messages) depending on your view preference. To change your view preference, refer to Section 3.4.2, “View Preference,” on page 3-10.

Resolve all faults first and then check the warnings. Take appropriate action to resolve the faults, as indicated in the following tables. In cases where there is more than one possible cause, they are listed from the “most likely” to the “least likely” cause. Actions are listed in the order that they should be performed; not all actions may need to be done.

Faults messages are displayed in the Messages pane in red lettering.

NOTE: If you have a red **STATUS** LED without a fault message, it probably indicates that the unit is locked out.

NOTE: The tables below contain messages for all versions of firmware.



Main Hub Faults

Table 9-1 Faults Reported by the Main Hub

Alarm Message	Action
{MF01} Software error occurred and recovered	If this happens repeatedly, replace the MH. (Log entry only.)
{MF02} Software error occurred and recovered	If this happens repeatedly, replace the MH. (Log entry only.)
{MF03} Software error occurred and recovered	If this happens repeatedly, replace the MH. (Log entry only.)
{MF04} Software error occurred and recovered	If this happens repeatedly, replace the MH. (Log entry only.)
{MF05} Software error occurred and recovered	If this happens repeatedly, replace the MH. (Log entry only.)
{MF06} MH power cycle	If AC mains are not cycled, replace the MH.
{MF09} Temperature is high	Replace the Main Hub if there is fan failure. Check fan for rotation, airflow blockage, and dust. Check room environmental controls.
{MF10} System Error Lockout	Check MH faults, system is out of service due to an MH fault.
{MF11} Commanded Out-of-Service	Command In-Service to restore operation.
{MF13} Hardware failure (Power Supply)	Replace the MH.
{MF14} Hardware failure (DL Laser)	Replace the MH.
{MF15} Failed to perform system test (PLL unlock)	Unable to perform system end-to-end test, replace the MH when possible.
{MF17} Hardware failure (SPI)	Cycle power once. If fault persists, replace the MH.
{MF18} Hardware failure (DL PLL Unlock)	Cycle power once. If fault persists, replace the MH.
{MF19} Hardware failure (DL PLL Unlock)	Cycle power once. If fault persists, replace the MH.
{MF20} Hardware failure (DL Pilot PLL Unlock)	Cycle power once. If fault persists, replace the MH.
{MF21} Hardware failure (UL PLL Unlock)	Cycle power once. If fault persists, replace the MH.
{MF22} Hardware failure (UL PLL Unlock)	Cycle power once. If fault persists, replace the MH.
{MF23} Hardware failure (UL PLL Unlock)	Cycle power once. If fault persists, replace the MH.

Table 9-1 Faults Reported by the Main Hub (continued)

{MF24}Frequency band not programmed	Use AdminManager to program the frequency band.
{MF25}Hardware failure (DL Pilot too low)	Cycle power once. If fault persists, replace the MH.
{MF26}Hardware failure (DL Pilot too high)	Cycle power once. If fault persists, replace the MH.
{MF27}Failed to perform system test (Test tone too high)	Unable to perform system end-to-end test, replace the Main Hub when possible.
{MF28}Failed to perform system test (Test tone too low)	Unable to perform system end-to-end test, replace the Main Hub when possible.
{MF29}Hardware failure (DL Path)	Replace the Main Hub.
{MF30}Hardware failure (UL Path)	Re-run system test. Swap first two EHs and re-run system test. If fault persists, replace the MH when possible.
{MF33}Port 1 UL RF path has excessive gain	If fault common to more than one port, replace the MH. If only one port has the fault, try another MH port. If no fault is reported, flag the previous port as unusable and replace the MH when possible. Otherwise, replace the EH.
{MF34} Port 2 UL RF path has excessive gain	If fault common to more than one port, replace the MH. If only one port has the fault, try another MH port. If no fault is reported, flag the previous port as unusable and replace the MH when possible. Otherwise, replace the EH.
{MF35} Port 3 UL RF path has excessive gain	If fault common to more than one port, replace the MH. If only one port has the fault, try another MH port. If no fault is reported, flag the previous port as unusable and replace the MH when possible. Otherwise, replace the EH.
{MF36} Port 4 UL RF path has excessive gain	If fault common to more than one port, replace the MH. If only one port has the fault, try another MH port. If no fault is reported, flag the previous port as unusable and replace the MH when possible. Otherwise, replace the EH.
{MF37} Port 1 UL RF path loss is too high	<p>The uplink RF loss is above the recommended minimum. If codes MS13-MS16 are also present, the fiber is the most likely problem. Clean the fiber ports and connectors. Ensure that the fiber connector is correctly seated.</p> <p>If codes MS13-MS16 are not present, disconnect both downlink and uplink fiber at the Main Hub. Wait 10 seconds, then re-connect downlink and uplink fiber.</p> <p>If fault common to more than one port, replace the MH. If only one port has the fault, try another MH port. If no fault is reported, flag the previous port as unusable and replace the MH when possible. Otherwise, replace the EH.</p>
{MF38} Port 2 UL RF path loss is too high	<p>The uplink RF loss is above the recommended minimum. If codes MS13-MS16 are also present, the fiber is the most likely problem. Clean the fiber ports and connectors. Ensure that the fiber connector is correctly seated.</p> <p>If codes MS13-MS16 are not present, disconnect both downlink and uplink fiber at the Main Hub. Wait 10 seconds, then re-connect downlink and uplink fiber.</p> <p>If fault common to more than one port, replace the MH. If only one port has the fault, try another MH port. If no fault is reported, flag the previous port as unusable and replace the MH when possible. Otherwise, replace the EH.</p>

Table 9-1 Faults Reported by the Main Hub (continued)

<p>{MF39} Port 3 UL RF path loss is too high</p>	<p>The uplink RF loss is above the recommended minimum. If codes MS13-MS16 are also present, the fiber is the most likely problem. Clean the fiber ports and connectors. Ensure that the fiber connector is correctly seated.</p> <p>If codes MS13-MS16 are not present, disconnect both downlink and uplink fiber at the Main Hub. Wait 10 seconds, then re-connect downlink and uplink fiber.</p> <p>If fault common to more than one port, replace the MH. If only one port has the fault, try another MH port. If no fault is reported, flag the previous port as unusable and replace the MH when possible. Otherwise, replace the EH.</p>
<p>{MF40} Port 4 UL RF path loss is too high</p>	<p>The uplink RF loss is above the recommended minimum. If codes MS13-MS16 are also present, the fiber is the most likely problem. Clean the fiber ports and connectors. Ensure that the fiber connector is correctly seated.</p> <p>If codes MS13-MS16 are not present, disconnect both downlink and uplink fiber at the Main Hub. Wait 10 seconds, then re-connect downlink and uplink fiber.</p> <p>If fault common to more than one port, replace the MH. If only one port has the fault, try another MH port. If no fault is reported, flag the previous port as unusable and replace the MH when possible. Otherwise, replace the EH.</p>
<p>{MF41} No communication with EH 1</p>	<p>If fault common to more than one port, replace the MH. If only one port has the fault, try another MH port. If no fault is reported, the MH fiber port is dirty or bad. Clean DL & UL fiber ports on both the MH and EH. Measure DL & UL optical loss. Check for flat polished fiber connectors. Replace the EH.</p>
<p>{MF42} No communication with EH 2</p>	<p>If fault common to more than one port, replace the MH. If only one port has the fault, try another MH port. If no fault is reported, the MH fiber port is dirty or bad. Clean DL & UL fiber ports on both the MH and EH. Measure DL & UL optical loss. Check for flat polished fiber connectors. Replace the EH.</p>
<p>{MF43} No communication with EH 3</p>	<p>If fault common to more than one port, replace the MH. If only one port has the fault, try another MH port. If no fault is reported, the MH fiber port is dirty or bad. Clean DL & UL fiber ports on both the MH and EH. Measure DL & UL optical loss. Check for flat polished fiber connectors. Replace the EH.</p>
<p>{MF44} No communication with EH 4</p>	<p>If fault common to more than one port, replace the MH. If only one port has the fault, try another MH port. If no fault is reported, the MH fiber port is dirty or bad. Clean DL & UL fiber ports on both the MH and EH. Measure DL & UL optical loss. Check for flat polished fiber connectors. Replace the EH.</p>
<p>{MF45} EH 1 disconnected</p>	<p>Try another port. If no connection, cycle EH power and confirm UL STATUS LED is green for 90 seconds. Check UL fiber connection(s). Clean fiber connectors and ports on MH and EH. Measure UL optical loss. Use “Clear All Disconnect Status” command to clear fault, or physically connect the EH.</p>
<p>{MF46} EH 2 disconnected</p>	<p>Try another port. If no connection, cycle EH power and confirm UL STATUS LED is green for 90 seconds. Check UL fiber connection(s). Clean fiber connectors and ports on MH and EH. Measure UL optical loss. Use “Clear All Disconnect Status” command to clear fault, or physically connect the EH.</p>

Table 9-1 Faults Reported by the Main Hub (continued)

{MF47}EH 3 disconnected	Try another port. If no connection, cycle EH power and confirm UL STATUS LED is green for 90 seconds. Check UL fiber connection(s). Clean fiber connectors and ports on MH and EH. Measure UL optical loss. Use "Clear All Disconnect Status" command to clear fault, or physically connect the EH.
{MF48}EH 4 disconnected	Try another port. If no connection, cycle EH power and confirm UL STATUS LED is green for 90 seconds. Check UL fiber connection(s). Clean fiber connectors and ports on MH and EH. Measure UL optical loss. Use "Clear All Disconnect Status" command to clear fault, or physically connect the EH.



Expansion Hub Faults

Table 9-2 Faults Reported by the Expansion Hub

Alarm Message	Action
{EF01}Software error occurred and recovered	If this happens repeatedly, replace the EH. (Log entry only.)
{EF02}Software error occurred and recovered	If this happens repeatedly, replace the EH. (Log entry only.)
{EF03}Software error occurred and recovered	If this happens repeatedly, replace the EH. (Log entry only.)
{EF04}Software error occurred and recovered	If this happens repeatedly, replace the EH. (Log entry only.)
{EF05}Software error occurred and recovered	If this happens repeatedly, replace the EH. (Log entry only.)
{EF06}Hardware failure (SPI)	Cycle power once. If fault persists, replace the EH.
{EF07}Temperature is too high	Replace the EH if fan failure. Check fan for rotation, airflow blockage, and dust. Check room environmental controls.
{EF08}Frequency band not programmed	Use AdminManager to program the frequency band.
{EF09}Hardware failure (PLL Unlock)	If fault common to more than one EH, replace the MH. If only one EH has the fault, try another MH port. If no fault is reported, flag the previous port as unusable and replace the MH when possible. Otherwise, replace the EH.
{EF10}Excessive DL optical loss	Normally this fault is only logged because the optical loss is below the absolute minimum. EH DL LED is red. Clean fiber connectors and ports, and check DL cable for excessive optical loss. If fault common to more than one EH, replace the MH. If only one EH has the fault, try another port on the MH. If no fault is reported, flag the previous port as unusable and replace the MH when possible. Otherwise, replace the EH.
{EF11}The DL RF path has excessive gain	If fault common to more than one EH, replace the MH. If only one EH has the fault, try another MH port. If no fault is reported, flag the previous port as unusable and replace the MH when possible. Otherwise, replace the EH.
{EF12}The DL RF path loss is too high	Clean fiber connectors and ports, and check DL cable for excessive optical loss. If fault common to more than one EH, replace the MH. If only one EH has the fault, try another port on the MH. If no fault is reported, flag the previous port as unusable and replace the MH when possible. Otherwise, replace the EH.
{EF13}Hardware failure possibly resulting in degraded performance	Replace the EH.
{EF14}Hardware failure possibly resulting in degraded performance	Replace the EH.
{EF15}Hardware failure (UL Laser)	Replace the EH.
{EF16}No MH communications	Clean fiber connectors and ports, and check cables for excessive optical loss. If fault common to more than one EH, replace the MH. If only one EH has the fault, try another port on the MH. If no fault is reported, flag the previous port as unusable and replace the MH when possible. Otherwise, replace the EH.

Table 9-2 Faults Reported by the Expansion Hub (continued)

{EF17}RAU 1 disconnected	Check Cat-5/5E/6 cable for shorts/opens, especially on new install. Try another EH port. If no fault is reported flag the previous port as unusable and replace the EH when possible. Otherwise, replace the RAU. Use “Clear All Disconnect Status” command to clear fault, or physically connect the RAU.
{EF18}RAU 2 disconnected	Check Cat-5/5E/6 cable for shorts/opens, especially on new install. Try another EH port. If no fault is reported flag the previous port as unusable and replace the EH when possible. Otherwise, replace the RAU. Use “Clear All Disconnect Status” command to clear fault, or physically connect the RAU.
{EF19}RAU 3 disconnected	Check Cat-5/5E/6 cable for shorts/opens, especially on new install. Try another EH port. If no fault is reported flag the previous port as unusable and replace the EH when possible. Otherwise, replace the RAU. Use “Clear All Disconnect Status” command to clear fault, or physically connect the RAU.
{EF20}RAU 4 disconnected	Check Cat-5/5E/6 cable for shorts/opens, especially on new install. Try another EH port. If no fault is reported flag the previous port as unusable and replace the EH when possible. Otherwise, replace the RAU. Use “Clear All Disconnect Status” command to clear fault, or physically connect the RAU.
{EF21}RAU 5 disconnected	Check Cat-5/5E/6 cable for shorts/opens, especially on new install. Try another EH port. If no fault is reported flag the previous port as unusable and replace the EH when possible. Otherwise, replace the RAU. Use “Clear All Disconnect Status” command to clear fault, or physically connect the RAU.
{EF22}RAU 6 disconnected	Check Cat-5/5E/6 cable for shorts/opens, especially on new install. Try another EH port. If no fault is reported flag the previous port as unusable and replace the EH when possible. Otherwise, replace the RAU. Use “Clear All Disconnect Status” command to clear fault, or physically connect the RAU.
{EF23}RAU 7 disconnected	Check Cat-5/5E/6 cable for shorts/opens, especially on new install. Try another EH port. If no fault is reported flag the previous port as unusable and replace the EH when possible. Otherwise, replace the RAU. Use “Clear All Disconnect Status” command to clear fault, or physically connect the RAU.
{EF24}RAU 8 disconnected	Check Cat-5/5E/6 cable for shorts/opens, especially on new install. Try another EH port. If no fault is reported flag the previous port as unusable and replace the EH when possible. Otherwise, replace the RAU. Use “Clear All Disconnect Status” command to clear fault, or physically connect the RAU.
{EF25}Port 1 UL RF path loss is too high	<p>CAT-5 cable is poorly terminated, re-crimp the connector; no RF uplink is detected at all.</p> <p>Check Cat-5E/6 cable loss, especially on new install. Check Cat-5 Extender, if present. If fault present on all EH ports, replace the EH. Otherwise, try another EH port. If no fault is reported, flag the previous port as unusable and replace the EH when possible. Otherwise, replace the RAU.</p>
{EF26} Port 2 UL RF path loss is too high	<p>CAT-5 cable is poorly terminated, re-crimp the connector; no RF uplink is detected at all.</p> <p>Check Cat-5E/6 cable loss, especially on new install. Check Cat-5 Extender, if present. If fault present on all EH ports, replace the EH. Otherwise, try another EH port. If no fault is reported, flag the previous port as unusable and replace the EH when possible. Otherwise, replace the RAU.</p>

Table 9-2 Faults Reported by the Expansion Hub (continued)

{EF27} Port 3 UL RF path loss is too high	<p>CAT-5 cable is poorly terminated, re-crimp the connector; no RF uplink is detected at all.</p> <p>Check Cat-5E/6 cable loss, especially on new install. Check Cat-5 Extender, if present. If fault present on all EH ports, replace the EH. Otherwise, try another EH port. If no fault is reported, flag the previous port as unusable and replace the EH when possible. Otherwise, replace the RAU.</p>
{EF28} Port 4 UL RF path loss is too high	<p>CAT-5 cable is poorly terminated, re-crimp the connector; no RF uplink is detected at all.</p> <p>Check Cat-5E/6 cable loss, especially on new install. Check Cat-5 Extender, if present. If fault present on all EH ports, replace the EH. Otherwise, try another EH port. If no fault is reported, flag the previous port as unusable and replace the EH when possible. Otherwise, replace the RAU.</p>
{EF29} Port 5 UL RF path loss is too high	<p>CAT-5 cable is poorly terminated, re-crimp the connector; no RF uplink is detected at all.</p> <p>Check Cat-5E/6 cable loss, especially on new install. Check Cat-5 Extender, if present. If fault present on all EH ports, replace the EH. Otherwise, try another EH port. If no fault is reported, flag the previous port as unusable and replace the EH when possible. Otherwise, replace the RAU.</p>
{EF30} Port 6 UL RF path loss is too high	<p>CAT-5 cable is poorly terminated, re-crimp the connector; no RF uplink is detected at all.</p> <p>Check Cat-5E/6 cable loss, especially on new install. Check Cat-5 Extender, if present. If fault present on all EH ports, replace the EH. Otherwise, try another EH port. If no fault is reported, flag the previous port as unusable and replace the EH when possible. Otherwise, replace the RAU.</p>
{EF31} Port 7 UL RF path loss is too high	<p>CAT-5 cable is poorly terminated, re-crimp the connector; no RF uplink is detected at all.</p> <p>Check Cat-5E/6 cable loss, especially on new install. Check Cat-5 Extender, if present. If fault present on all EH ports, replace the EH. Otherwise, try another EH port. If no fault is reported, flag the previous port as unusable and replace the EH when possible. Otherwise, replace the RAU.</p>
{EF32} Port 8 UL RF path loss is too high	<p>CAT-5 cable is poorly terminated, re-crimp the connector; no RF uplink is detected at all.</p> <p>Check Cat-5E/6 cable loss, especially on new install. Check Cat-5 Extender, if present. If fault present on all EH ports, replace the EH. Otherwise, try another EH port. If no fault is reported, flag the previous port as unusable and replace the EH when possible. Otherwise, replace the RAU.</p>
{EF33}Port 1 DL RF path too low	<p>Try another port, if fault persists replace the EH. Otherwise, flag previous port as unusable and replace the EH when possible</p>
{EF34}Port 2 DL RF path too low	<p>Try another port, if fault persists replace the EH. Otherwise, flag previous port as unusable and replace the EH when possible</p>
{EF35}Port 3 DL RF path too low	<p>Try another port, if fault persists replace the EH. Otherwise, flag previous port as unusable and replace the EH when possible</p>
{EF36}Port 4 DL RF path too low	<p>Try another port, if fault persists replace the EH. Otherwise, flag previous port as unusable and replace the EH when possible</p>

Table 9-2 Faults Reported by the Expansion Hub (continued)

{EF37}Port 5 DL RF path too low	Try another port, if fault persists replace the EH. Otherwise, flag previous port as unusable and replace the EH when possible
{EF38}Port 6 DL RF path too low	Try another port, if fault persists replace the EH. Otherwise, flag previous port as unusable and replace the EH when possible
{EF39}Port 7 DL RF path too low	Try another port, if fault persists replace the EH. Otherwise, flag previous port as unusable and replace the EH when possible
{EF40}Port 8 DL RF path too low	Try another port, if fault persists replace the EH. Otherwise, flag previous port as unusable and replace the EH when possible
{EF41}No communication with RAU 1	Check Cat-5/5E/6 cable for shorts/opens, especially on new install. Try another EH port. If no fault is reported, flag the previous port as unusable and replace the EH when possible. Otherwise, replace the RAU.
{EF42}No communication with RAU 2	Check Cat-5/5E/6 cable for shorts/opens, especially on new install. Try another EH port. If no fault is reported, flag the previous port as unusable and replace the EH when possible. Otherwise, replace the RAU.
{EF43}No communication with RAU 3	Check Cat-5/5E/6 cable for shorts/opens, especially on new install. Try another EH port. If no fault is reported, flag the previous port as unusable and replace the EH when possible. Otherwise, replace the RAU.
{EF44}No communication with RAU 4	Check Cat-5/5E/6 cable for shorts/opens, especially on new install. Try another EH port. If no fault is reported, flag the previous port as unusable and replace the EH when possible. Otherwise, replace the RAU.
{EF45}No communication with RAU 5	Check Cat-5/5E/6 cable for shorts/opens, especially on new install. Try another EH port. If no fault is reported, flag the previous port as unusable and replace the EH when possible. Otherwise, replace the RAU.
{EF46}No communication with RAU 6	Check Cat-5/5E/6 cable for shorts/opens, especially on new install. Try another EH port. If no fault is reported, flag the previous port as unusable and replace the EH when possible. Otherwise, replace the RAU.
{EF47}No communication with RAU 7	Check Cat-5/5E/6 cable for shorts/opens, especially on new install. Try another EH port. If no fault is reported, flag the previous port as unusable and replace the EH when possible. Otherwise, replace the RAU.
{EF48}No communication with RAU 8	Check Cat-5/5E/6 cable for shorts/opens, especially on new install. Try another EH port. If no fault is reported, flag the previous port as unusable and replace the EH when possible. Otherwise, replace the RAU.
{EF49}RAU 1 over current	<p>Port power trip. Disconnect the CAT-5 cable and issue 'Clear All Disconnects' command. The EH port LEDs should be Off/Off. If they are not, the port has been damaged and can no longer be used. Check the CAT-5 cable, re-crimp the connector. If the fault persists, replace the RAU.</p> <p>Check Cat-5E/6 cable for shorts/opens, especially on new install. Try another EH port. If no fault is reported, flag the previous port as unusable and replace the EH when possible. Otherwise, replace the RAU. Use "Clear All Disconnect Status" command to clear fault, or power-cycle the EH.</p>

Table 9-2 Faults Reported by the Expansion Hub (continued)

{EF50}RAU 2 over current	<p>Port power trip. Disconnect the CAT-5 cable and issue 'Clear All Disconnects' command. The EH port LEDs should be Off/Off. If they are not, the port has been damaged and can no longer be used. Check the CAT-5 cable, re-crimp the connector. If the fault persists, replace the RAU.</p> <p>Check Cat-5E/6 cable for shorts/opens, especially on new install. Try another EH port. If no fault is reported, flag the previous port as unusable and replace the EH when possible. Otherwise, replace the RAU. Use “Clear All Disconnect Status” command to clear fault, or power-cycle the EH.</p>
{EF51}RAU 3 over current	<p>Port power trip. Disconnect the CAT-5 cable and issue 'Clear All Disconnects' command. The EH port LEDs should be Off/Off. If they are not, the port has been damaged and can no longer be used. Check the CAT-5 cable, re-crimp the connector. If the fault persists, replace the RAU.</p> <p>Check Cat-5E/6 cable for shorts/opens, especially on new install. Try another EH port. If no fault is reported, flag the previous port as unusable and replace the EH when possible. Otherwise, replace the RAU. Use “Clear All Disconnect Status” command to clear fault, or power-cycle the EH.</p>
{EF52}RAU 4 over current	<p>Port power trip. Disconnect the CAT-5 cable and issue 'Clear All Disconnects' command. The EH port LEDs should be Off/Off. If they are not, the port has been damaged and can no longer be used. Check the CAT-5 cable, re-crimp the connector. If the fault persists, replace the RAU.</p> <p>Check Cat-5E/6 cable for shorts/opens, especially on new install. Try another EH port. If no fault is reported, flag the previous port as unusable and replace the EH when possible. Otherwise, replace the RAU. Use “Clear All Disconnect Status” command to clear fault, or power-cycle the EH.</p>
{EF53}RAU 5 over current	<p>Port power trip. Disconnect the CAT-5 cable and issue 'Clear All Disconnects' command. The EH port LEDs should be Off/Off. If they are not, the port has been damaged and can no longer be used. Check the CAT-5 cable, re-crimp the connector. If the fault persists, replace the RAU.</p> <p>Check Cat-5E/6 cable for shorts/opens, especially on new install. Try another EH port. If no fault is reported, flag the previous port as unusable and replace the EH when possible. Otherwise, replace the RAU. Use “Clear All Disconnect Status” command to clear fault, or power-cycle the EH.</p>
{EF54}RAU 6 over current	<p>Port power trip. Disconnect the CAT-5 cable and issue 'Clear All Disconnects' command. The EH port LEDs should be Off/Off. If they are not, the port has been damaged and can no longer be used. Check the CAT-5 cable, re-crimp the connector. If the fault persists, replace the RAU.</p> <p>Check Cat-5E/6 cable for shorts/opens, especially on new install. Try another EH port. If no fault is reported, flag the previous port as unusable and replace the EH when possible. Otherwise, replace the RAU. Use “Clear All Disconnect Status” command to clear fault, or power-cycle the EH.</p>

Table 9-2 Faults Reported by the Expansion Hub (continued)

{EF55}RAU 7 over current	<p>Port power trip. Disconnect the CAT-5 cable and issue 'Clear All Disconnects' command. The EH port LEDs should be Off/Off. If they are not, the port has been damaged and can no longer be used. Check the CAT-5 cable, re-crimp the connector. If the fault persists, replace the RAU.</p> <p>Check Cat-5E/6 cable for shorts/opens, especially on new install. Try another EH port. If no fault is reported, flag the previous port as unusable and replace the EH when possible. Otherwise, replace the RAU. Use "Clear All Disconnect Status" command to clear fault, or power-cycle the EH.</p>
{EF56}RAU 8 over current	<p>Port power trip. Disconnect the CAT-5 cable and issue 'Clear All Disconnects' command. The EH port LEDs should be Off/Off. If they are not, the port has been damaged and can no longer be used. Check the CAT-5 cable, re-crimp the connector. If the fault persists, replace the RAU.</p> <p>Check Cat-5E/6 cable for shorts/opens, especially on new install. Try another EH port. If no fault is reported, flag the previous port as unusable and replace the EH when possible. Otherwise, replace the RAU. Use "Clear All Disconnect Status" command to clear fault, or power-cycle the EH.</p>
{EF60} Internal fault lockout	<p>Check the EH for faults. EH/RAUs are out of service on command from the EH.</p>
{EF61} External fault lockout	<p>Check the MH for faults. The EH/RAUs are out of service on command of the MH.</p>
{EF62} Commanded Out-of-Service	<p>Command In-Service to restore operation.</p>
{EF63} 36 VAC Shutdown	<p>36 VAC shutdown due to EH over temperature. Automatic recovery is possible when internal ambient temperature drops below 65 degrees Centigrade.</p>



Remote Access Unit Faults

Table 9-3 Faults Reported by the RAU

Alarm Message	Action
{RF01} Software error occurred and recovered	If this happens repeatedly, replace the RAU. (Log entry only.)
{RF02} Software error occurred and recovered	If this happens repeatedly, replace the RAU. (Log entry only.)
{RF03} Software error occurred and recovered	If this happens repeatedly, replace the RAU. (Log entry only.)
{RF04} Software error occurred and recovered	If this happens repeatedly, replace the RAU. (Log entry only.)
{RF05} Software error occurred and recovered	If this happens repeatedly, replace the RAU. (Log entry only.)
{RF06} Hardware failure (SPI)	Cycle the power once. If the fault persists, replace the RAU
{RF09} Temperature is too high	Check for proper installation. Check environmental controls, move the RAU to a cooler environment.
{RF10} DC Power supplied by the EH/Accel Hub is too low	Check the CAT-5E/6 cable for shorts/opens, especially on new installations. Check the CAT-5 Extender, if present. If the fault is common to more than one RAU, replace the EH/Accel Hub. Try another port. If no fault is reported, flag the previous port as unusable and replace the Hub when possible. Otherwise, replace the RAU.
{RF11} DC Power supplied by the EH/Accel Hub is too high	Check the CAT-5E/6 cable for shorts/opens, especially on new installation. Check the CAT-5 Extender, if present. If the fault is common to more than one RAU, replace the EH/Accel Hub. Try another port. If no fault is reported, flag the previous port as unusable and replace the Hub when possible. Otherwise, replace the RAU.
{RF12} Hardware failure (PA)	Replace the RAU.
{RF13} Hardware failure (PA)	Replace the RAU.
{RF14} Hardware failure (PLL Unlock)	Check the CAT-5E/6 cable for shorts/opens, especially on new installations. Check the CAT-5 Extender, if present. If the fault is common to more than one RAU, replace the EH/Accel Hub. Try another port. If no fault is reported, flag the previous port as unusable and replace the Hub when possible. Otherwise, replace the RAU.
{RF15} The DL RF path loss is too high	Check the CAT-5E/6 cable for shorts/opens, especially on new installations. Check the CAT-5 Extender, if present. If the fault is common to more than one RAU, replace the EH/Accel Hub. Try another port. If no fault is reported, flag the previous port as unusable and replace the Hub when possible. Otherwise, replace the RAU.
{RF16} DL RF path operating at minimum gain	Check the CAT-5E/6 cable for shorts/opens, especially on new installations. Check the CAT-5 Extender, if present, and validate that minimum cable length requirements are met. If the fault is common to more than one RAU, replace the EH/Accel Hub. Try another port. If no fault is reported, flag the previous port as unusable and replace the Hub when possible. Otherwise, replace the RAU.
{RF17} Hardware failure	Replace the RAU

Table 9-3 Faults Reported by the RAU (continued)

{RF18}Potential failure in the UL RF path	Unable to complete the system end-to-end. Replace the RAU when possible.
{RF19}Potential failure in the DL RF path	Unable to complete the system end-to-end test. Check the RAU termination at the SMA connector and re-test it. Replace the RAU if there are no Hub alarms.
{RF20}No communications with the EH/Accel Hub	Check the CAT-5E/6 cable for shorts/opens, especially on new installations. Check the CAT-5 Extender, if present. If the fault is common to more than one RAU, replace the EH/Accel Hub. Try another port. If no fault is reported, flag the previous port as unusable and replace the Hub when possible. Otherwise, replace the RAU.
{RF21}The DL RF path loss is above the recommended limit	Check the CAT-5E/6 cable for shorts/opens, especially on new installations. Check the CAT-5 Extender, if present. If the fault is common to more than one RAU, replace the EH/Accel Hub. Try another port. If no fault is reported, flag the previous port as unusable and replace the Hub when possible. Otherwise, replace the RAU.
{RF22}Frequency band not programmed	Use AdminManager to check band support in the RAU. Cycle power once. If the fault persists, replace the RAU.
{RF23}Commanded Out-of-Service	Command In-Service to restore service.
{RF24}External fault lockout	Check the Hubs for faults. The RAU is out of service on command from the Hub.
{RF25}Internal fault lockout	Check RAU faults. The RAU is out of service.

9.3.1.3 Warning Indications

Warnings alert you to conditions that indicate possible service impact. Warnings are displayed in the Messages pane in orange lettering.

NOTE: AdminManager v2.04 or higher displays events (faults, warnings, or status messages) depending on your view preference. To change your view preference, refer to Section 3.4.2, “View Preference,” on page 3-10.

Before addressing warnings, ensure that all faults are resolved. Take appropriate action to resolve the warnings, as indicated in the following tables.



Main Hub Warnings

Table 9-4 Warnings Reported by the Main Hub

Warning Message	Action
{MW01}DL signal from RF source is excessive	Reduce DL signal from RF source (base station or bi-directional amplifier).
{MW02}Temperature is high	Replace the MH if there is fan failure. Check fan rotation, airflow blockage, and dust. Check room environmental controls.
{MW20}Hardware failure (DL Path)	Replace the MH when possible.

Table 9-4 Warnings Reported by the Main Hub (continued)

{MW21}Hardware failure (UL Path)	Re-run system test. If warning persists, move EH to another port and re-run system test. If warning persists, replace the MH when possible.
{MW22}Hardware failure (DL Pilot too low)	Cycle power once. If warning persists, replace the MH when possible.
{MW25}Port 1 UL RF path has excessive gain	If the warning is common to more than one port, replace the MH when possible. If only one port has the warning, try another MH port. If no warning is reported, flag the previous port as unusable and replace the MH when possible. Otherwise, replace the EH when possible.
{MW26}Port 2 UL RF path has excessive gain	If the warning is common to more than one port, replace the MH when possible. If only one port has the warning, try another MH port. If no warning is reported, flag the previous port as unusable and replace the MH when possible. Otherwise, replace the EH when possible.
{MW27}Port 3 UL RF path has excessive gain	If the warning is common to more than one port, replace the MH when possible. If only one port has the warning, try another MH port. If no warning is reported, flag the previous port as unusable and replace the MH when possible. Otherwise, replace the EH when possible.
{MW28}Port 4 UL RF path has excessive gain	If the warning is common to more than one port, replace the MH when possible. If only one port has the warning, try another MH port. If no warning is reported, flag the previous port as unusable and replace the MH when possible. Otherwise, replace the EH when possible.
{MW29}Port 1 UL RF path is too high	<p>Uplink RF loss is above the recommended minimum. If codes MS13-MS16 is also present, the fiber is the most likely problem. Clean the fiber ports and connectors. Ensure that the fiber connector is correctly seated.</p> <p>If codes MS13-MS16 are not present, disconnect both downlink and uplink fiber at the Main Hub. Wait 10 seconds, then re-connect downlink and uplink fiber.</p> <p>If the warning is common to more than one port, replace the MH when possible. If only one port has the warning, try another MH port. If no warning is reported, flag the previous port as unusable and replace the MH when possible. Clean the optical connectors and ports. If the warning persists, replace the EH when possible.</p>
{MW30}Port 2 UL RF path is too high	<p>Uplink RF loss is above the recommended minimum. If codes MS13-MS16 is also present, the fiber is the most likely problem. Clean the fiber ports and connectors. Ensure that the fiber connector is correctly seated.</p> <p>If codes MS13-MS16 are not present, disconnect both downlink and uplink fiber at the Main Hub. Wait 10 seconds, then re-connect downlink and uplink fiber.</p> <p>If the warning is common to more than one port, replace the MH when possible. If only one port has the warning, try another MH port. If no warning is reported, flag the previous port as unusable and replace the MH when possible. Clean the optical connectors and ports. If the warning persists, replace the EH when possible.</p>

Table 9-4 Warnings Reported by the Main Hub (continued)

<p>{MW31}Port 3 UL RF path is too high</p>	<p>Uplink RF loss is above the recommended minimum. If codes MS13-MS16 is also present, the fiber is the most likely problem. Clean the fiber ports and connectors. Ensure that the fiber connector is correctly seated.</p> <p>If codes MS13-MS16 are not present, disconnect both downlink and uplink fiber at the Main Hub. Wait 10 seconds, then re-connect downlink and uplink fiber.</p> <p>If the warning is common to more than one port, replace the MH when possible. If only one port has the warning, try another MH port. If no warning is reported, flag the previous port as unusable and replace the MH when possible. Clean the optical connectors and ports. If the warning persists, replace the EH when possible.</p>
<p>{MW32}Port 4 UL RF path is too high</p>	<p>Uplink RF loss is above the recommended minimum. If codes MS13-MS16 is also present, the fiber is the most likely problem. Clean the fiber ports and connectors. Ensure that the fiber connector is correctly seated.</p> <p>If codes MS13-MS16 are not present, disconnect both downlink and uplink fiber at the Main Hub. Wait 10 seconds, then re-connect downlink and uplink fiber.</p> <p>If the warning is common to more than one port, replace the MH when possible. If only one port has the warning, try another MH port. If no warning is reported, flag the previous port as unusable and replace the MH when possible. Clean the optical connectors and ports. If the warning persists, replace the EH when possible.</p>



Expansion Hub Warnings

Table 9-5 Warnings Reported by the Expansion Hub

Warning Message	Action
{EW21}The DL RF path has excessive gain	If the warning is common to more than one EH, replace the MH. If only one EH has the warning, try another MH port. If no warning is reported, flag the previous port as unusable and replace the MH when possible. Otherwise, replace the EH when possible.
{EW22}The DL RF path loss is too high	Downlink RF loss is above the recommended minimum. If ES01 is also present, the fiber is the most likely problem. Clean the fiber ports and connectors. Ensure the fiber is correctly seated. If ES01 is not present, disconnect both downlink and uplink fiber at the Main Hub. Wait 10 seconds, then re-connect downlink and uplink fiber. Check the DL cable for excessive optical loss. If the warning is common to more than one EH, replace the MH when possible. If only one EH has the warning, try another port on the MH. If no warning is reported, flag the previous port as unusable and replace the MH when possible. Otherwise, replace the EH when possible
{EW23}Hardware problem. Possible degraded performance	Replace the EH when possible.
{EW24}Hardware problem. Possible degraded performance	Replace the EH when possible.
{EW33}Contact closure 1 warning active	Contact closure 1 indicates an active warning. AC may have failed.
{EW34}Contact closure 2 warning active	Contact closure 2 indicates an active warning. UPS battery may be low.
{EW35}Contact closure 3 warning active	Contact closure 3 indicates an active warning.

Note: * applies to Firmware version 5.1 or earlier



Remote Access Unit Warnings

Table 9-6 Warnings Reported by the RAU

Warning Message	Action
{RW17}The DL RF path loss is too high	<p>CAT-5 cable is poorly terminated, re-crimp the connector; no RF uplink is detected at all.</p> <p>Check the CAT-5E/6 cable for shorts/opens, especially on new installations. Check the CAT-5 Extender, if present. If the warning is common to more than one RAU, replace the EH/Accel Hub. Try another port. If no warning is reported, flag the previous port as unusable and replace the Hub when possible. Otherwise, replace the RAU when possible.</p>
{RW18}DL RF path operating at minimum gain	<p>Check CAT-5E/6 cable loss, especially on new installations. Check the CAT-5 Extender, if present, and validate that minimum cable length requirements are met. If the warning is common to more than one RAU, replace the EH/Accel Hub when possible. Try another port. If no warning is reported, flag the previous port as unusable and replace the Hub when possible. Otherwise, replace the RAU when possible.</p>
{RW19}Antenna Disconnected	<p>Check the antenna connection and rerun the system test. (You can select the antenna disconnect reporting for status or warning.)</p>

9.3.1.4 Status Messages

Status messages alert you to conditions that are important but do not generally impact service. Status messages are displayed in the Messages pane in blue lettering.

NOTE: AdminManager v2.04 or higher displays events (faults, warnings, or status messages) depending on your view preference. To change your view preference, refer to Section 3.4.2, “View Preference,” on page 3-10.

NOTE: The icons displayed in the system status tree assume that there are no other faults or warnings present.





Main Hub Status Messages

Table 9-7 Status Messages Reported by the Main Hub

Status Message	Action
[MS03]Downlink laser is failing	Replace the MH when possible.
[MS04]Fan failure	Check the fan for rotation, airflow blockage, and dust. Replace the MH on high temperature warning.
[MS05]Commanded Out-of-Service	Command In-service to restore operation.
[MS06]Factory special test mode	Cycle the power to clear.
[MS07]System Lockout	Check the MH for faults.
[MS08]Unable to perform system test on power up	Check the EHs and RAUs for faults. Re-run system test.
[MS09]EH1/RAU reports warning condition	Check EH 1 and the RAU for warnings.
[MS10]EH2/RAU reports warning condition	Check EH 2 and the RAU for warnings.
[MS11]EH3/RAU reports warning condition	Check EH 3 and the RAU for warnings.
[MS12]EH4/RAU reports warning condition	Check EH 4 and the RAU for warnings.
[MS13]Port 1 UL fiber interface has high optical loss	Uplink optical loss is above the recommended minimum. If periodic messages MF45-MF48 (EH disconnects) occur, the fiber optical loss is near the absolute minimum. Excessive uplink optical loss may also result in MW29-MF32 codes. Clean the fiber cable connectors and ports.

Table 9-7 Status Messages Reported by the Main Hub (continued)

[MS14]Port 2 UL fiber interface has high optical loss	Uplink optical loss is above the recommended minimum. If periodic messages MF45-MF48 (EH disconnects) occur, the fiber optical loss is near the absolute minimum. Excessive uplink optical loss may also result in MW29-MF32 codes. Clean the fiber cable connectors and ports.
[MS15]Port 3 UL fiber interface has high optical loss	Uplink optical loss is above the recommended minimum. If periodic messages MF45-MF48 (EH disconnects) occur, the fiber optical loss is near the absolute minimum. Excessive uplink optical loss may also result in MW29-MF32 codes. Clean the fiber cable connectors and ports.
[MS16]Port 4 UL fiber interface has high optical loss	Uplink optical loss is above the recommended minimum. If periodic messages MF45-MF48 (EH disconnects) occur, the fiber optical loss is near the absolute minimum. Excessive uplink optical loss may also result in MW29-MF32 codes. Clean the fiber cable connectors and ports.
[MS17]Failed to perform system test (PLL unlock)	Unable to perform system end-to-end test, replace the MH when possible.
[MS18]Failed to perform system test (Test tone too high)	Unable to perform system end-to-end test, replace the MHb when possible.
[MS19]Failed to perform system test (Test tone too low)	Unable to perform system end-to-end test, replace the MH when possible.
[MS23] Scheduled system test completed	Scheduled system test completed, log entry only.
[MS33] Time Tagged Log Full	Use AdminManager to dump and save the Time-Tagged Log, then erase it.
[MS34] Time of day not initialized	Use AdminManager to initialize the time and date.
[MS36] Maximum auto-recovery limit	Maximum number of fault/warning auto-recovery attempts. Use AdminManager to “Set In-Service” to allow the MH to attempt additional auto-recovery attempts.

NOTE: If your equipment is using release 3.1 firmware, the  icon is displayed instead of , except for “unable to perform system test on power up”.





Expansion Hub Status Messages

Table 9-8 Status Messages Reported by the Expansion Hub

Status Message	Action
[ES01]The DL fiber interface has high optical loss	Downlink optical loss is above THE recommended minimum. If codes MF41-MF44 (EH no communications) are observed, the fiber optical loss is near the absolute minimum. Excessive downlink optical loss may also result with ES02/EW22 codes Clean the fiber connectors and ports, and check the DL cable for excessive optical loss.
[ES02]The DL RF path loss is above the recommended limit	Downlink RF loss is above the recommended minimum. If ES01 is also present, the fiber is the most likely problem. Clean the fiber ports and connectors. Ensure the fiber is correctly seated. If ES01 is not present, disconnect both downlink and uplink fiber at the Main Hub. Wait 10 seconds, then re-connect downlink and uplink fiber.
[ES03]UL laser is failing	Replace the Expansion Hub when possible.
[ES04]System test required*	Run the system test.
[ES05]Temperature is high	Check the fan for rotation, air flow blockage, and dust. Check the room environmental controls.
[ES06]Fan 1 failure	Check the fan for rotation, air flow blockage, and dust. Replace the EH on temperature fault.
[ES07]Fan 2 failure	Check the fan for rotation, air flow blockage, and dust. Replace the EH on temperature fault.
[ES08]Fan 3 failure	Check the fan for rotation, air flow blockage, and dust. Replace the EH on temperature fault.
[ES09]Port 1 UL RF path loss is above the recommended limit	Uplink RF is below the recommended minimum; the CAT-5 cable may be longer than the recommended minimum. Check the CAT-5E/6 cable, especially on new installations. Check the CAT-5 Extender, if present. Use the CAT-5 Extender to improve coverage.
[ES10]Port 2 UL RF path loss is above the recommended limit	Uplink RF is below the recommended minimum; the CAT-5 cable may be longer than the recommended minimum. Check the CAT-5E/6 cable, especially on new installations. Check the CAT-5 Extender, if present. Use the CAT-5 Extender to improve coverage.
[ES11]Port 3 UL RF path loss is above the recommended limit	Uplink RF is below the recommended minimum; the CAT-5 cable may be longer than the recommended minimum. Check the CAT-5E/6 cable, especially on new installations. Check the CAT-5 Extender, if present. Use the CAT-5 Extender to improve coverage.
[ES12]Port 4 UL RF path loss is above the recommended limit	Uplink RF is below the recommended minimum; the CAT-5 cable may be longer than the recommended minimum. Check the CAT-5E/6 cable, especially on new installations. Check the CAT-5 Extender, if present. Use the CAT-5 Extender to improve coverage.

Table 9-8 Status Messages Reported by the Expansion Hub (continued)

[ES13]Port 5 UL RF path loss is above the recommended limit	Uplink RF is below the recommended minimum; the CAT-5 cable may be longer than the recommended minimum. Check the CAT-5E/6 cable, especially on new installations. Check the CAT-5 Extender, if present. Use the CAT-5 Extender to improve coverage.
[ES14]Port 6 UL RF path loss is above the recommended limit	Uplink RF is below the recommended minimum; the CAT-5 cable may be longer than the recommended minimum. Check the CAT-5E/6 cable, especially on new installations. Check the CAT-5 Extender, if present. Use the CAT-5 Extender to improve coverage.
[ES15]Port 7 UL RF path loss is above the recommended limit	Uplink RF is below the recommended minimum; the CAT-5 cable may be longer than the recommended minimum. Check the CAT-5E/6 cable, especially on new installations. Check the CAT-5 Extender, if present. Use the CAT-5 Extender to improve coverage.
[ES16]Port 8 UL RF path loss is above the recommended limit	Uplink RF is below the recommended minimum; the CAT-5 cable may be longer than the recommended minimum. Check the CAT-5E/6 cable, especially on new installations. Check the CAT-5 Extender, if present. Use the CAT-5 Extender to improve coverage.
[ES17]Commanded Out-of-Service	Command In-service to restore operation.
[ES18]External fault lockout	Check the MH for faults.
[ES20]Factory special test mode	Cycle the power to clear the test mode.
[ES25]Port 1 DL RF path too low	Try another port. If the status persists, replace the EH. Otherwise, flag the previous port as unusable and replace the EH when possible.
[ES26]Port 2 DL RF path too low	Try another port. If the status persists, replace the EH. Otherwise, flag the previous port as unusable and replace the EH when possible.
[ES27]Port 3 DL RF path too low	Try another port. If the status persists, replace the EH. Otherwise, flag the previous port as unusable and replace the EH when possible.
[ES28]Port 4 DL RF path too low	Try another port. If the status persists, replace the EH. Otherwise, flag the previous port as unusable and replace the EH when possible.
[ES29]Port 5 DL RF path too low	Try another port. If the status persists, replace the EH. Otherwise, flag the previous port as unusable and replace the EH when possible.
[ES30]Port 6 DL RF path too low	Try another port. If the status persists, replace the EH. Otherwise, flag the previous port as unusable and replace the EH when possible.
[ES31]Port 7 DL RF path too low	Try another port. If the status persists, replace the EH. Otherwise, flag the previous port as unusable and replace the EH when possible.
[ES32]Port 8 DL RF path too low	Try another port. If the status persists, replace the EH. Otherwise, flag the previous port as unusable and replace the EH when possible.



NOTE: If your equipment is using release 3.1 firmware, the  icon is displayed instead of , except for “unit not system tested”.



Remote Access Unit Status Messages

Table 9-9 Status Messages Reported by the RAU

Status Message	Action
[RS01]Temperature is high	Check for proper installation. Check the environmental controls, move the RAU to a cooler environment.
[RS02]DC voltage is low	Check the CAT-5E/6 cable for shorts/opens, especially on new installations. Check the CAT-5 Extender, if present. If the status message persists, replace the RAU when possible.
[RS03]Power amplifier is failing	Replace the RAU when possible.
[RS05] The cable loss between EH/Accel Hub and RAU is above the recommended limit	The downlink RF is below the recommended minimum; the CAT-5 cable may be longer than recommended. Check the CAT-5E/6 cable for shorts/opens, especially on new installations. Check the CAT-5 Extender, if present. If the status is common to more than one RAU, replace the EH/Accel Hub when possible. Use the CAT-5 Extender to improve coverage.
[RS06]System test required	Run the system test.
[RS07]Antenna disconnected	Check antenna connection and re-run system test. Note: With Firmware Release 5.5 and later, this alarm can be configured as either a status or a warning message (RW19).
[RS09]Commanded Out-of-Service	Command In-service to restore operation. Note: Message displays in Firmware Release 5.5 or earlier.
[RS10]External fault lockout	Check the Hubs for faults. Note: Message displays in Firmware Release 5.5 or earlier.
[RS11]Internal fault lockout	Check the RAU faults. The RAU is out-of-service. Note: Message displays in Firmware Release 5.5 or earlier.
[RS13]DC Power supplied by the Expansion/Accel Hub is too high	Check the CAT-5E/6 cable for shorts/opens, especially on new installations. Check the CAT-5 Extender, if present. If the status is common to more than one RAU, replace the EH/Accel Hub when possible. Try another port. If no status is reported, flag the previous port as unusable and replace the Hub when possible. Otherwise, replace the RAU when possible.
[RS14]Potential failure in the UL RF path	Unable to complete system end-to-end test. Replace the RAU when possible
[RS15]Potential failure in the DL RF path	Unable to complete system end-to-end test. Check the RAU termination at the SMA connector and re-test. Replace the RAU if there are no Hub alarms.
[RS16]Factory special test mode	Cycle the power to clear the test mode.

NOTE: If your equipment is using release 3.1 firmware, the  icon is displayed instead of , except for “unit not system tested”.

9.3.2 Troubleshooting using LEDs

The following troubleshooting guide is from the perspective that all Unison equipment is installed, their cables are connected, and they are powered on; it is assumed that the system was operating normally before the problem to be diagnosed occurred. (Refer to Section 7 for information on troubleshooting during initial installation of the system.)

Always use AdminManager, if possible, to troubleshoot the system. The LEDs are for backup troubleshooting; although, an Expansion Hub uplink laser failure can only be resolved using the **EH UL STATUS** LED.

Begin with troubleshooting the Main Hub’s LEDs and then the Expansion Hub’s LEDs. The RAU LEDs probably will not provide additional information for troubleshooting.

9.3.2.1 Troubleshooting Main Hub LEDs During Normal Operation

- All of the Main Hub’s LEDs should be green during normal operation. If any LEDs are red, get status using AdminManager to determine the exact cause and recommendations.

Table 9-10 Troubleshooting Main Hub Port LEDs During Normal Operation

During Normal Operation	Main Hub Port LEDs	State	Action	Impact
Expansion Hub Not Connected	LINK	Red	If the Expansion Hub was disconnected accidentally, re-connect the cables. The LEDs should change to Green/Red (then Green/Green, after 20 seconds, if the Main Hub band has been programmed). When the Expansion Hub is to be removed from service permanently, use AdminManager’s ‘Clear All Disconnect Status’ command to clear all disconnect states to no connect states.	The Expansion Hub was previously connected, but it is not currently connected; the Expansion Hub uplink cable disconnected. AdminManager clears all disconnects caused by installation as part of the clean-up process. After installation, power cycle the Main Hub or use AdminManager’s “Clear All Disconnect Status” command. Changes the Main Hub’s port LEDs to Off/Off.
	E-HUB/RAU	Off		

Table 9-10 Troubleshooting Main Hub Port LEDs During Normal Operation

During Normal Operation	Main Hub Port LEDs	State	Action	Impact
Expansion Hub Connected	LINK	Red	Use AdminManager to determine the exact cause of the Main Hub's faults.	Lost communication with Expansion Hub; could be Expansion Hub problem or fiber cable problem. The Expansion Hub communication problems delay MH responses to AdminManager commands, resulting in command time-outs. You can disconnect the offending Expansion Hub initially to obtain status from the rest of the system, then connect the Expansion Hub and resolve the communication problem.
	E-HUB/RAU	Off		
	LINK	Green	The Expansion Hub or connected RAU reports a fault condition; use AdminManager to determine the exact cause of the Expansion Hub and RAU's faults.	Degraded performance or unit may be off-line. Depends on fault condition.
	E-HUB/RAU	Red		

Table 9-11 Troubleshooting Main Hub Status LEDs During Normal Operation

During Normal Operation	Main Hub Status LEDs	State	Action	Impact
At Any Time	MAIN HUB STATUS	Red	Use AdminManager to determine the exact cause of the fault. Power cycle one time. If the fault remains, replace the Main Hub.	Internal Main Hub fault.
			Use AdminManager to check if the Main Hub is commanded Out-of-Service (every Expansion Hub port status LED will be red as well). A power cycle will not clear a commanded Out-of-Service, you must use AdminManager to clear this state.	The Main Hub and all downstream units are off-line.
	MAIN HUB STATUS	Alternating Red/Green	Reduce input signal power.	Signal compression.

Note: * applies to earlier firmware versions.

9.3.2.2 Troubleshooting Expansion Hub LEDs During Normal Operation

- All of the Expansion Hub **LINK** and **E-HUB/RAU** LEDs that have RAUs connected should be Green/Green, indicating that the RAU is powered on, communication is established, and operation is normal.
- The **POWER**, **EHUB STATUS**, **DL STATUS**, and **UL STATUS** LEDs should all be Green.

Table 9-12 Troubleshooting Expansion Hub Port LEDs During Normal Operation

During Normal Operation	Expansion Hub Port LEDs	State	Action	Impact
RAU is not connected	LINK	Red	If the RAU was disconnected accidentally, re-connect the CAT-5/5E/6 cable. The Expansion Hub's port LEDs should change to Green/Red (then Green/Green, after 20 seconds, if the Main Hub is connected, powered on, and has band programmed). Use AdminManager's "Clear All Disconnect Status" command if you are permanently removing the RAU from service. The Expansion Hub's port LEDs should change to Off/Off.	The RAU was previously connected, but it is not currently connected; the RAU cable is disconnected.
	RAU	Off		
RAU is connected	LINK	Red	Disconnect/reconnect the CAT-5/5E/6 cable to force power-on reset to the RAU. If the port LEDs remain Red/Off, check for the exact cause of Expansion Hub faults using AdminManager.	Lost communications with the RAU. The RAU could have powered down due to over current; cable could have been damaged.
	RAU	Off		
	LINK	Green	The RAU reports a fault condition; check for the exact cause of Expansion Hub and RAU faults using AdminManager.	Depends on the fault condition.
	RAU	Red		

Table 9-13 Troubleshooting Expansion Hub Status LEDs During Normal Operation

During Normal Operation	Expansion Hub Status LEDs	State	Action	Impact
At Any Time	UL STATUS	Red	Check uplink fiber for optical loss. Power cycle Expansion Hub one time to check uplink laser.	No communications between the Main Hub and the Expansion Hub. Uplink laser failure.
	DL STATUS	Red	Check the downlink fiber for optical loss	No communications with the Main Hub.
	E-HUB STATUS	Red	If either the UL STATUS or the DL STATUS are also red, see above. Cycle power on the Expansion Hub. If fault remains, replace the Expansion Hub.	Internal Expansion Hub fault (including either of the above UL STATUS or DL STATUS states).

NOTE: When you power cycle the Expansion Hub the **UL STATUS** LED should be green for approximately 90 seconds before it turns red. If it isn't, replace the Expansion Hub.

9.4 Troubleshooting CAT-5/5E/6

Refer to Table A-1 on page A-1 for a description of the CAT-5/5E/6 wire assignment. The following table summarizes CAT-5/5E/6 problems if a wire is cut or not wired properly.

Table 9-14 Summary of Cat-5/5E/6 Cable Wiring Problems







































Type of problem	Message	Icon	Icon*	Impact
Wire 1 or 2 cut	None			High phase noise, degraded signal on both Downlink and Uplink (high bit error rate)
Wire 3 or 6 cut	<ul style="list-style-type: none"> No communication with RAUn 			RAU unable to communicate with EH, decreased UL gain, or no UL gain
Wire 4 or 5 cut	<ul style="list-style-type: none"> Portn UL RF path loss is too high 			Increased ripple in the uplink path, decreased UL gain, or no UL gain
	<ul style="list-style-type: none"> Portn UL RF path loss is higher than recommended 			
Wire 7 or 8 cut	<ul style="list-style-type: none"> The DL RF path loss is too high 			Increased ripple in the downlink path, RAU off-line
	<ul style="list-style-type: none"> The DL RF path loss is higher than recommended 			
Wire 1 to RJ-45 pin 3 or 6	<ul style="list-style-type: none"> No communication with RAUn 			RAU unable to communicate with EH, RAU's RS-485 port damaged, degraded performance or RAU off-line
Wire 1 to RJ-45 pin 4, 5, 7 or 8	<ul style="list-style-type: none"> RAUn over current 			RAU will not power on.
Wire 2 to RJ-45 pin 3 or 6	<ul style="list-style-type: none"> No communication with RAUn 			RAU unable to communicate with EH, RAU's RS-485 port damaged, degraded performance or RAU off-line
Wire 2 to RJ-45 pin 4, 5, 7 or 8	<ul style="list-style-type: none"> RAUn over current 			RAU will not power on
Wire 3 to RJ-45 pin 4, 5, 7 or 8	<ul style="list-style-type: none"> No communication with RAUn 			RAU unable to communicate with EH, degraded performance or RAU off-line
Wire 6 to RJ-45 pin 4, 5, 7 or 8	<ul style="list-style-type: none"> No communication with RAUn 			RAU unable to communicate with EH, degraded performance or RAU off-line
Wire 4 to RJ-45 pin 7 or 8	<ul style="list-style-type: none"> Portn UL RF path loss is too high 			Increased ripple in the downlink and uplink path, degraded performance or RAU off-line
	<ul style="list-style-type: none"> Portn UL RF path loss is higher than recommended 			
	<ul style="list-style-type: none"> The DL RF path loss is too high 			
	<ul style="list-style-type: none"> The DL RF path loss is higher than recommended 			

Table 9-14 Summary of Cat-5/5E/6 Cable Wiring Problems (continued)

Type of problem	Message	Icon	Icon*	Impact
Wire 5 to RJ-45 pin 7 or 8	<ul style="list-style-type: none"> Portn UL RF path loss is too high 			Increased ripple in the downlink and uplink path, degraded performance or RAU off-line
	<ul style="list-style-type: none"> Portn UL RF path loss is higher than recommended 			
	<ul style="list-style-type: none"> The DL RF path loss is too high 			
	<ul style="list-style-type: none"> The DL RF path loss is higher than recommended 			

9.5 Technical Assistance

Call the ADC help hot line for technical assistance:

1-800-530-9960 (U.S. only)

+1-408-952-2400 (International)

Please provide your name, phone number, and e-mail address, along with the following information. An ADC customer service representative will contact you with assistance.

- Company name
- End user name
- Type of system, model number, frequency
- Approximate time in service (warranty), sales order number
- Description of problem
- LED status
- AdminManager faults, warnings, and status messages

This page is intentionally left blank.

Cables and Connectors

A.1 CAT-5E/6 Cable (ScTP)

- Connects the Expansion Hub to the RAU(s)
- Transmits (downlink) and receives (uplink) IF signals
- Delivers DC electrical power to the RAU(s). The Expansion Hub's DC voltage output is 36V DC nominal. A current limiting circuit is used to protect the Expansion Hub if it reaches its current limit
- Carries configuration and status information
- Use shielded RJ-45 connectors
- Distances:
 - Minimum: 10 meters (33 ft)
 - Recommended Maximum: 100 meters (328 ft)
 - Absolute Maximum: 150 meters (492 ft)

Refer to *Cat-5/5E/6 Cabling Requirements for Unison Family* Field Note (FN04-001) for more information.

There are four separate twisted pairs in one CAT-5E/6 screened twisted pair (ScTP) cable. The ScTP cable loss described in this document is for CAT-5 Belden 1624P DataTwist Five cable, or equivalent. Table A-1 lists the functional assignment of the pairs:

Table A-1 CAT-5E/6 Twisted Pair Assignment

Pair (wire number)	Function
1 & 2	Clock and Input Voltage
3 & 6	RS-485
4 & 5	Uplink IF, UL Pilot and Ground
7 & 8	Downlink IF, DL Pilot and Ground

All CAT-5E/6 cable must be terminated according to the TIA/EIA 568-A standard. Figure A-1 shows the top view of the wiring map for the cable and how the four pairs should be terminated.

Figure A-1 Wiring Map for Cat-5E/6 Cable

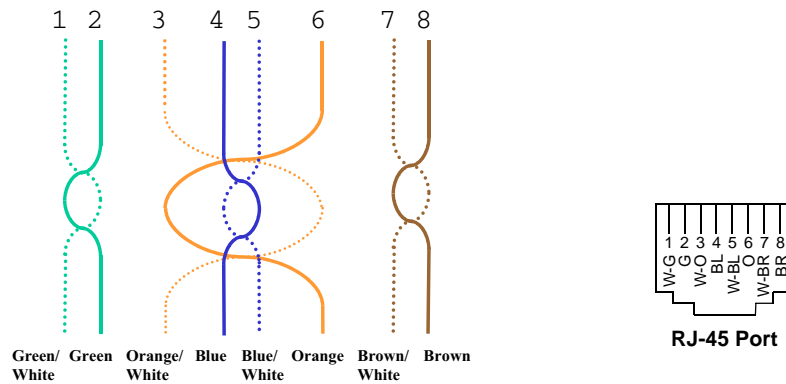

The nominal DC impedance of the CAT-5E/6 cable is 0.08 ohm/meter and the nominal RF impedance is 100 ohm.

NOTE: Be sure to test cable termination before installing the cable.

NOTE: Belden 1624P DataTwist® Five ScTP cable, or equivalent is required. Belden 1533P/R DataTwist® Five ScTP cable or equivalent is required for CAT-5E. Additionally, Commscope 5ES4/5ENS4 may also be used for CAT-5E. In order to meet FCC and CE Mark emissions requirements, the CAT-5/5E/6 cable must be screened (ScTP) and it must be grounded to the units at both ends (that is, RAU and Expansion Hub) using shielded RJ-45 connectors.

A.2 Fiber Optical Cables

- Connects the Main Hub to Expansion Hub(s)
- Transmits (downlink) and receives (uplink) optical signals
- Carries configuration and status information
- Use industry-standard 62.5µm/125µm MMF or Corning SMF-28 fiber, or equivalent.
- SC/APC (angle-polished) connectors are required throughout the fiber network (port-to-port), including fiber distribution panels
- Distances:
 - Multi-mode Fiber: up to 1.5 km (4,921 ft) – 3 dB optical loss maximum
 - Single-mode Fiber: up to 6 km (19,685 ft) – 3 dB optical loss maximum

A.3 Coaxial Cable

- Connects a Main Hub to a repeater or base station (N-type connectors)
- Connects an RAU to a passive antenna (SMA connectors)

A.4 Standard Modem Cable

- Connects a modem to the Main Hub's front panel serial port

Figure A-2 Standard Modem Cable Pinout

DB-9 Connector Pin	DB-25 Connector Pin
1	8
2	3
3	2
4	20
5	7
6	6
7	4
8	5
9	22

A.5 DB-9 to DB-9 Null Modem Cable

Use a DB-9 female to DB-9 female null modem cable to connect the AdminManager PC to a Unison Main Hub. A cable is included with AdminManager. Table A-2 lists the cable pinout and Figure A-3 shows a diagram of its wiring.

Table A-2 DB-9 Female to DB-9 Female Null Modem Cable Pinout

From	Signal	To	Signal
P1-4	DTR	P2-6, P2-1	DSR, DCD
P1-6	DSR	P1-1, P2-4	DCD, DTR
P1-3	TXD	P2-2	RXD
P1-2	RXD	P2-3	TXD
P1-5	GND	P2-5	GND
P1-7	RTS	P2-8	CTS
P1-8	CTS	P2-7	RTS
P1-9	N/C	N/C	N/C

Figure A-3 DB-9 Female to DB-9 Female Null Modem Cable Diagram

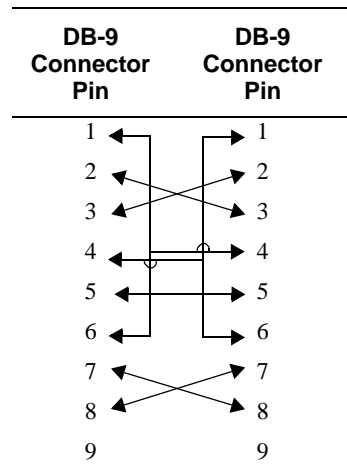

Note that for each DB-9 connector, pins 1 and 6 are tied together and sent to pin 4 of the opposite connector, providing the required handshake signals.

A.6 DB-25 to DB-9 Null Modem Cable

A DB-25 male to DB-9 female Null modem cable connects a 232 Port Expander to a Unison Main Hub, or to connect a modem to the Main Hub when using OpsConsole to monitor the system. Table A-3 lists the pinout of the cable for Unison and Figure A-4 shows a diagram of its wiring.

Table A-3 DB-25 Male to DB-9 Female Null Modem Cable Pinout

25-Pin	Signal	9-Pin	Signal
20	DTR	1, 6	DSR, DCD
2	TX	2	RX
3	RX	3	TX
6,8	DSR, DCD	4	DTR
7	GND	5	GND
5	CTS	7	RTS
4	RTS	8	CTS

Figure A-4 DB-25 Male to DB-9 Female Null Modem Cable Diagram

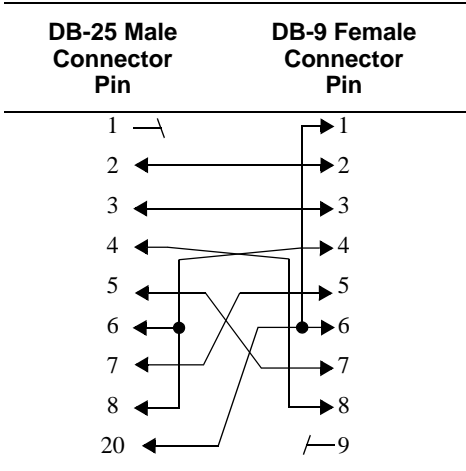

This page is intentionally left blank.

B.1 Unison System Approval Status

900 Paging/SMR

- Safety: UL 60950 3rd Edition
- EMC: FCC part 15 class A
- Radio: FCC Part 90

Cellular Products

- Safety: UL 60950 3rd Edition
- EMC: FCC part 15 class A
- Radio: FCC Part 22

DCS Products

- Safety: CB scheme evaluation to IEC 950, 3rd Edition with all national deviations
- EMC: EN 301 489-8 V.1.1.1 (2000-09), CISPR 24: 1998
- Radio: ETS 300 609-4 V.8.0.2 (2000-10)

GSM Products

- Safety: CB scheme evaluation to IEC 950, 3rd Edition with all national deviations
- Radio: EN 301 502 V.7.0.1 (2000-08)
- EMC: EN 301 489-8 V.1.1.1 (2000-09), CISPR 24: 1998

iDEN Products

- Safety: UL 60950, 3rd Edition
- EMC: FCC part 15 class A
- Radio: FCC part 90

PCS Products

- Safety: UL 60950 3rd Edition
- EMC: FCC part 15 class A
- Radio: FCC part 24
- Radio: FCC part 22

UMTS Products

- Safety: CB scheme evaluation to IEC 950, 3rd Edition with all national deviations
- EMC: ETSI TS 125 113 V.4.1.0 (2001-06)
- Radio: ETSI TS 125 143 V.4.0.0 (2001-03)

AWS Products

- Safety: UL 60950 3rd Edition and 60950-1 1st Edition
- EMC: FCC part 15 class A
- Radio: FCC part 27

Public Safety 700 MHz Products

- Safety: UL, CSA, CB Scheme certificate to IEC 60950, 3rd Edition, and IEC 60950-1, 1st Edition, with all national deviations
- EMC: FCC part 15 class A
- Radio: FCC part 27

700 MHz LTE Products

- Safety: UL, CSA, CB Scheme certificate to IEC 60950, 3rd Edition, and IEC 60950-1, 1st Edition, with all national deviations
- EMC: FCC part 15 class A
- Radio: FCC part 27

NOTE: For Canadian customers, the Manufacturer's rated output power¹ of this equipment is for single carrier operation. For situations when multiple carrier signals are present, the rating would have to be reduced by 3.5 dB, especially where the output signal is re-radiated and can cause interference to adjacent band users. This power reduction is to be by means of input power or gain reduction and not by an attenuator at the output of the device.

NOTE: This device complies with Part 15 of the FCC Rules. Operation is subject to the following two conditions: (1) this device may not cause harmful interference, and (2) this device must accept any interference received, including interference that may cause undesired operation.

NOTE: This equipment has been tested and found to comply with the limits for a Class A digital device, pursuant to Part 15 of the FCC Rules. These limits are designed to provide reasonable protection against harmful interference when the equipment is operated in a commercial environment. This equipment generates, uses, and can radiate radio frequency energy and, if not installed and used in accordance with the instruction manual, may cause harmful interference to radio communications.

This equipment complies with the FCC radiation exposure limits for general population/uncontrolled exposure environments.

Changes or modifications not approved and performed by ADC may void the user's authority to operate the equipment.

B.2 Human Exposure to RF

The U.S. Federal Communications Commission (FCC) has developed guidelines for evaluation of human exposure to RF emissions. The guidelines incorporate limits for Maximum Permissible Exposure (MPE) for power density of transmitters operating at frequencies between 300 kHz and 100 GHz. Limits have been set for portable, mobile, and fixed equipment. ADC products fall in the category of fixed equipment; products intended to be permanently secured and exposures are evaluated for dis-

1. "Manufacturer's rated output power" refers to Unison's downlink P1dB. The power per carrier tables take into account this power reduction for multiple carriers.

tances greater than 20cm (7 7/8”). Portable devices fall into exposures of less than 20cm, are SAR evaluations are used.

Antenna gain is restricted to 1.5 W ERP (2.49 W EIRP) in order to satisfy RF exposure compliance requirements. If higher than 1.5 W ERP, routine MPE evaluation is needed. The antennas should be installed to provide at least 20 cm from all persons to satisfy MPE requirements of FCC Part 2, 2.1091.

Basic MPE evaluation is performed by taking the maximum power output of the equipment, the gain of the antenna to be used, and distance from the antenna, referenced in FCC OET Bulletin 65 “*Evaluation Compliance with FCC Guidelines for Human Exposure to Radio Frequency for Electric Fields*”.

ADC products transmit well below the FCC power density limits. FCC defines power output limits at 20cm distance for various frequency ranges:

- Over 300 MHz to 1.5 GHz the limit is determined by frequency/1500
- Above 1.5 GHz the limit is 1mW/cm²

The basic equation for determining power density is:

$$S = PG / 4\pi R^2$$

Where **S** is power density in mW/cm²

PG, the transmitted power from the antenna identified as EIRP (Equivalent Isotropically Radiated Power), is the product of power output of device and antenna gain, in mW.

R is the distance of interest from the antenna.

Typical Installation Example:

Assuming an antenna is placed on a 10 foot ceiling, for a person 6 feet tall, the distance from antenna to body is 4 feet (112 cm.).

For a PCS 1900 or Cell 850 remote unit, the maximum power output, according to the power table in Section 6.3 Maximum Output Power per Carrier on page 6-4, is 16.5 dB.

Assuming a 7 dBi antenna is used, PG in the equation is equal to 23.5 dB (224 mW) EIRP.

Using $S = PG/4\pi R^2$

$$S = 224/(4 \times 3.14) \times (112)^2 = 0.001 \text{ mW/cm}^2$$

Also, assuming a minimum distance of 20 cm according to FCC regulations”

$$S = 224/(4 \times 3.14) \times (20)^2 = 0.04 \text{ mW/cm}^2$$

Changes and New Capabilities

To check the firmware version of any Unison component, launch AdminManager and right-click on the component icon (main hub, expansion hub, or RAU) in the hierarchical tree. Select “Get Information” in the pull down menu.

ADC recommends that you use the latest firmware to optimize operations of your Unison system. The latest firmware can be downloaded through the ADC Customer Portal, accessible through our main website at www.adc.com.

C.1 New in Rev. M of Manual

- Support for Unison 700 MHz LTE band.

C.2 New in Rev. L of Manual

- Added reference to “Unison Release 5.8” Field Note (FN08-001).

C.3 New in Rev. K of Manual

- Support for 700 MHz Public Safety band

C.4 New in Rev. J of Manual

- Support for two new AWS bands

C.5 New in Rev. H. of Manual

- Supports scheduled system test.
- Supports 1 dB step attenuator and antenna disconnect in UMTS-2.
- Antenna disconnect alarm is user selectable between status and warning.
- Bookmarks for navigational ease
- Link to the ADC customer portal for on-line configuration tools and product compatibility information
- Supports UPS contact closure (UNS-EH-2 only) monitoring at the Expansion Hub
- Support for 4 new PCS bands
- New system configuration screen shot
- Updated Maintenance and troubleshooting section

C.6 New in Rev. G of Manual

- Ability to filter warnings and status messages
- Reclassification of some faults to warnings and some warnings to status messages. Faults are service impacting. Warnings are possible service impacting. Status messages are internal states that could impact service but not at the current time.

C.7 New in Rev. F of Manual

- Added additional reference to Japan Specification Document

C.8 New in Rev. E of Manual

- Added reference to Japan Specification Document

C.9 New in Rev. D of Manual

- Supports 35 MHz PCS RAU
- Refer to “Unison Release 5.1” Field Note (FN03-007, formerly FN-024)

C.10 New in Rev. C of Manual

- Power per Carrier tables
- Removed DCS3
- EGSM is a subset of GSM
- Unison Cat-5 Extender added
- Dual-band Diplexer added

C.11 New in Rev. B of Manual

- Supports GSM and EGSM frequency bands using the GSM RAU
Frequencies: DL 1815–1850 MHz, UL 1720–1755 MHz
- Supports globally downloading firmware updates to multiple units at the same time (that is, all RAUs in a system, then all of the Expansion Hubs, and finally the Main Hub)
- Supports reclassification of status messages

This page is intentionally left blank.

New in Rev. B of Manual

Glossary

Air Interface A method for formatting data and voice onto radio waves. Common air interfaces include AMPS, TDMA, CDMA, and GSM.

AIN Advanced Intelligent Network. AINs allow a wireless user to make and receive phone calls while roaming outside the user's "home" network. These networks, which rely on computers and sophisticated switching techniques, also provide many Personal Communications Service (PCS) features.

Amplitude The distance between high and low points of a waveform or signal.

AMPS Advanced Mobile Phone Service. AMPS is an analog cellular FDMA system. It was the basis of the first commercial wireless communication system in the U.S and has been used in more than 35 other countries worldwide.

Analog The original method of modulating radio signals so they can carry information which involves transmitting a continuously variable signal. Amplitude Modification (AM) and Frequency Modulation (FM) are the most common methods of analog modulation.

ANSI The American National Standards Institute. A nonprofit, privately funded membership organization founded in 1918 that reviews and approves standards developed by other organizations.

AWS Advanced Wireless Services

Antenna A device for transmitting and/or receiving signals.

Attenuation The decrease in power that occurs when any signal is transmitted. Attenuation is measured in decibels (dB).

Backhaul A term applied to the process of carrying wireless traffic between the MSC and the base station.

Base Station The radio transmitter/receiver that maintains communications with mobile devices within a specific area.

BSC Base Station Controller. A GSM term referring to the device in charge of managing the radio interface in a GSM system, including the allocation and release of radio channels and hand-off of active calls within the system.

BTA Basic Trading Area. The U.S. and its territories are divided into 493 areas, called BTAs. These BTAs are composed of a specific list of counties, based on a system originally developed by Rand McNally. The FCC grants licenses to wireless operators to provide service within these BTAs and/or MTAs. (See MTA.)

BTS Base Transceiver Station. A GSM term referring to the group of network devices that provide radio transmission and reception, including antennas.

C/I Carrier to interference ratio. The ratio of the desired signal strength to the combined interference of all mobile phones using the system. Usually, the interference of most concern is that provided by mobile phones using the same channel in the system. These are referred to as “co-channel interferers.”

CCITT Consultative Committee on International Telephone and Telegraph. This organization sets international communications standards. The CCITT is now known as ITU (the parent organization).

CDMA Code Division Multiple Access. A digital wireless access technology that uses spread-spectrum techniques. Unlike alternative systems, such as GSM, that use time-division multiplexing (TDM), CDMA does not assign a specific frequency to each user. Instead, every channel uses the full available spectrum. Individual conversations are assigned a unique code which allows the conversation to be spread out over multiple channels; transmitted to the far end; and re-assembled for the recipient using a specific code.

CDPD Cellular Digital Packet Data. CDPD allows data transmission over the analog wireless network. CDPD breaks data into packets and transmits these packets on idle portions of the network.

Cell A cell defines a specific, physical area of coverage of a portion of a wireless system. It is the basic “building block” of all modern wireless communications systems.

Cell Site A term which refers to the location of the transmission equipment (e.g., basestation) within the cell.

CEPT Conference of European Postal and Telecommunications Administrations. This organization’s mandate is to define pan-European wireless communications standards. In 1982, CEPT mandated GSM as the access protocol for public wireless communications systems across Europe.

Channel The path along which a communications signal is transmitted. Channels may be simplex (communication occurs in only one direction), duplex (communication occurs in both directions) or full duplex (communication occurs in both directions simultaneously).

Circuit A communication connection between two or more points. A circuit can transmit either voice or data.

CO Central Office. The main switching facility for a telecommunications system.

CTIA Cellular Telecommunications Industry Association. The CTIA is an industry association made up of most of the wireless carriers and other industry players. It was formed in 1984 to promote the cellular industry and cellular technology.

D-AMPS Digital Advanced Mobile Phone Service. See IS-54.

dB Decibel. A unit for expressing the ratio of two amounts of power. It is often used in wireless to describe the amount of power loss in a system (i.e., the ratio of transmitted power to received power).

DCS Digital Communications System. DCS is often called “upbanded GSM” since it is the GSM access scheme adopted to operate in the 1700–1800 MHz portion of the spectrum.

Digital A method of storing, processing, and transmitting information by representing information as “0s” and “1s” via electrical pulses. Digital systems have largely replaced analog systems because they can carry more data at higher speed than analog transmission systems.

Electromagnetic Spectrum Electrical wave forms in frequency ranges as low as 535 kHz (AM radio) and as high as 29 GHz (cable TV).

ESMR Enhanced Specialized Mobile Radio. Digital mobile telephone services offered to the public over channels previously used for two-way analog dispatch services. ESMR provides digital mobile radio and telephone service as well as messaging and dispatch features.

ETSI European Telecommunications Standards Institute. ETSI was established in 1988 to set standards for Europe in telecommunications, broadcasting and office information technology.

FCC Federal Communications Commission. In the United States, the FCC is responsible for the management and regulation of communication policy for all public communications services, including wireless.

FDMA Frequency Division Multiple Access. A wireless access protocol that assigns each user a specific radio channel for use. Since FDMA only supports one user (or conversation) on each channel, it does not maximize use of the spectrum and is therefore largely been superseded by other access protocols (such as CDMA, TDMA, GSM, iDEN) that support multiple users on a single channel.

Frequency Hopping A wireless signal transmission technique whereby the frequency used to carry a signal is periodically changed, according to a predetermined code, to another frequency.

Fixed An ITU definition for radio communications between specified fixed points. Point-to-point high-frequency circuits and microwave links are two examples of fixed applications.

FM Frequency Modulation. A method of transmitting information in which the frequency of the carrier is modified according to a plan agreed to by the transmitter and the receiver. FM can be either analog or digital.

Forward Channel Refers to the radio channel that sends information from the base station to the mobile station. (See Reverse Channel.)

Frequency The number of times an electrical signal repeats an identical cycle in a unit of time, normally one second. One Hertz (Hz) is one cycle per second.

Frequency re-use The ability to use the same frequencies repeatedly across a cellular system. Because each cell is designed to use radio frequencies only within its boundaries, the same frequencies can be reused in other cells not far away with little potential for interference. The reuse of frequencies is what enables a cellular system to handle a huge number of calls with a limited number of channels.

Gain The increase in power that occurs when any signal is amplified, usually through an amplifier or antenna.

GHz Gigahertz. A measure of frequency equal to one billion hertz.

GSM Groupe Speciale Mobile (now translated in English as Global Standard for Mobile Communications). GSM is the digital wireless standard used throughout Europe, in much of Asia, as well as by some operators in the U.S. and South America.

Handoff The process by which the wireless system passes a wireless phone conversation from one radio frequency in one cell to another radio frequency in another as the caller moves between two cells. In most systems today, this handoff is performed so quickly that callers don't notice.

Hertz A measurement of electromagnetic energy, equivalent to one "wave" per second. Hertz is abbreviated as "Hz".

iDEN Integrated Digital Enhanced Network. A TDMA-based wireless access technology that combines two-way radio, telephone, text message, and data transmission into one network. This system was developed by Motorola. In the U.S., iDEN is used by Nextel in its network.

IEEE The Institute of Electrical and Electronics Engineers. The world's largest technical professional society with members from more than 130 countries. The IEEE works to advance the theory and practice of electrical, electronics, computer engineering and computer science.

Infrastructure A term used to encompass all of the equipment, including both hardware and software, used in a communications network.

IS-54 Interim Standard-54. A U.S. TDMA cellular standard that operates in the 800 MHz or 1900 MHz band. IS-54 was the first U.S. digital cellular standard. It was adopted by the CTIA in 1990.

IS-95 Interim Standard-95. A U.S. CDMA cellular standard that operates in the 800 MHz or 1900 MHz band. This standard was developed by Qualcomm and adopted by the CTIA in 1993.

IS-136 Interim Standard-136. A U.S. TDMA cellular standard based on IS-54 that operates in the 800 MHz or 1900 MHz band.

IS-553 Interim Standard-533. The U.S. analog cellular (AMPS) air interface standard.

ITU International Telecommunications Union. The ITU is the principal international standards organization. It is chartered by the United Nations and it establishes international regulations governing global telecommunications networks and services. Its headquarters are in Geneva, Switzerland.

LMDS Local Multipoint Distribution Services. LMDS provides line-of-sight coverage over distances up to 3–5 kilometers and operates in the 28 GHz portion of the spectrum. It can deliver high speed, high bandwidth services such as data and video applications.

Local Loop A communication channel (usually a physical phone line) between a subscriber's location and the network's Central Office.

LTE Long Term Evolution.

MHz Megahertz. One million Hertz. One MHz equals one million cycles per second.

Microcell A network cell designed to serve a smaller area than larger macrocells. Microcells are smaller and lower powered than macrocells. As the subscriber base increases, operators must continue to increase the number of cells in their network to maximize channel re-use. This has led to an increasing number of microcells being deployed in wireless networks.

Microwave Electromagnetic waves with frequencies above 1 GHz. Microwave communications are used for line-of-sight, point-to-point, or point-to-multipoint communications.

MSA Metropolitan Statistical Area. The FCC has established 306 MSAs in the U.S. The MSAs represent the largest population centers in the U.S. At least two wireless operators are licensed in each MSA.

MSC Mobile Services Switching Center. A generic term for the main cellular switching center in the wireless communications network.

MSS Mobile Satellite Service. Communications transmission service provided by satellites. A single satellite can provide coverage to the entire United States.

MTA Major Trading Area. The U.S. and its territories are divided into 51 MTAs. Each MTA is composed of a specific number of BTAs. The FCC grants licenses to wireless operators to provide service within these MTAs and/or BTAs. (See BTA.)

Multiplexing The simultaneous transmission of two or more signals on the same radio (or other) transmission facility.

N-AMPS Narrowband Advanced Mobile Phone Service.

PCMCIA Personal Computer Memory Card International Association. This acronym is used to refer to credit card sized packages containing memory, I/O devices and other capabilities for use in Personal Computers, handheld computers and other devices.

PCS Personal Communications Service. A vague label applied to new-generation mobile communication technology that uses the narrow band and broadband spectrum recently allocated in the 1.9 GHz band.

PDA Personal Digital Assistant. Portable computing devices that are extremely portable and that offer a variety of wireless communication capabilities, including paging, electronic mail, stock quotations, handwriting recognition, facsimile, calendar, and other information handling capabilities.

PDC Personal Digital Cellular (formerly Japanese Digital Cellular). A TDMA-based digital cellular standard that operates in the 1500 MHz band.

Phase The particular angle of inflection of a wave at a precise moment in time. It is normally measured in terms of degrees.

PHS Personal Handyphone System. A wireless telephone standard, developed and first deployed in Japan. It is a low mobility, small-cell system.

POP Short for "population". One person equals one POP.

POTS Plain Old Telephone Service.

POTS Plain Old Telephone Service.

PS Public Safety.

Reverse Channel Refers to the radio channel that sends information from a mobile station to a base station. (See Forward Channel.)

RF Radio Frequency. Those frequencies in the electromagnetic spectrum that are associated with radio wave propagation.

Roaming The ability to use a wireless phone to make and receive calls in places outside one's home calling area.

RSA Rural Service Area. One of the 428 FCC-designated rural markets across the United States used as license areas for cellular licenses. (See MTAs and BTAs.)

Sector A portion of a cell. Often, different sectors within the same cell will each use a different set of frequencies to maximize spectrum utilization.

Signal to Noise Ratio The ratio of signal power to noise power at a given point in a given system.

Smart Antenna Refers to an antenna whose signal handling characteristics change as signal conditions change.

Soft Handoff Virtually undetectable by the user, soft handoff allows both the original cell and a new cell to serve a call temporarily during the handoff transition.

Spectrum The range of electromagnetic frequencies.

Spread Spectrum A method of transmitting a signal over a broad range of frequencies and then re-assembling the transmission at the far end. This technique reduces interference and increases the number of simultaneous conversations within a given radio frequency band.

T-1 A North American commercial digital transmission standard. A T-1 connection uses time division multiplexing to carry 24 digital voice or data channels over copper wire.

TDMA Time Division Multiple Access. A method of digital wireless communications that allows multiple users to access (in sequence) a single radio frequency channel without interference by allocating unique time slots to each user within each channel.

TIA Telecommunications Industry Association.

TR-45 One of six committees of the Telecommunications Industry Association. TR-45 oversees the standard making process for wireless telecommunications.

Upbanded A service or technology that has been re-engineered to operate at a higher frequency than originally designed.

Wireless Describes any radio-based system that allows transmission of voice and/or data signals through the air without a physical connection, such as a metal wire or fiber optic cable.

Wireline Wire paths that use metallic conductors to provide electrical connections between components of a system, such as a communication system.

WLANs Wireless Local Area Networks. Technology that provides wireless communications to Portable Computer users over short distances.



This page is intentionally left blank.