



Test Report Summary
FCC CFR 47, Part 24
Subpart E Broadband PCS
FCC CFR 47, Part 90
Private Land Mobile Radio Service

Manufacturer: ADC Telecommunications

Name of Equipment: Spectrum 800 Path 2/PCS Path 2 SRAU

Model Number(s): SPT-S1-8019-22

Manufacturer's Address: 541 E Trimble Road
San Jose, CA 95131 USA

Test Report Number: MN120130 800P2 PCSP2 SRAU

Test Date(s): 17 and 18 January, 2012 (Intertek)
25 May, 2011 (ADC)
12 and 13 October, November 9, 2011 (ADC)

According to testing performed at Intertek, the above-mentioned unit is in accordance with the applicable electromagnetic compatibility (EMC) portions of the requirements defined in FCC Part 90 and 24.

It is the manufacturer's responsibility to assure that additional production units of this model are manufactured with identical electrical and mechanical characteristics. Any modifications necessary for compliance made during testing on the above mentioned date(s) must be implemented in all production units for compliance to be maintained.

All testing was done in accordance with the Federal Communications Commission's CFR 47 Part 90 and 24. The EUT fulfills the requirements of the Federal Communications Commission's CFR 47 Part 90 and 24.

Date: 30 January, 2012

Location: Intertek Testing Services (INTERTEK)
7250 Hudson Blvd., Suite 100
Oakdale, MN 55128
Phone: (651) 730-1188
Fax: (651) 730-1282

ADC Telecommunications
1187 Park Place
Shakopee, MN 55379
Phone: (952) 403-8340
Fax: (952) 403-8858

Testing Conducted by (ADC):
And Report Written by:

Joshua J. Wittman
Compliance Engineer



EMC Emission – T E S T R E P O R T

Test Report File Number: MN120130 800P2 PCSP2 SRAU

Date of Issue: 30 January, 2012

Model Number(s): SPT-S1-8019-22

Product Name: Spectrum 800 Path 2/PCS Path 2 SRAU

Product Type: Repeater

Applicant: ADC Telecommunications

Manufacturer: ADC Telecommunications

License Holder: ADC Telecommunications

Address: P.O. Box 1101
Minneapolis, MN 55440-1101

Test Result: **Positive** Negative

Test Project Number: **100616112MIN-001**

Reference(s)

Total pages including Appendices: 72



1.0 TABLE OF CONTENTS

1.0	Table of Contents	3
2.0	Revision Description	4
3.0	Documentation	4
3.1	Test Regulations	4
3.2	Test Operation Mode	5
3.3	Configuration of the Device Under Test:	5
3.4	Product Options:	5
3.5	EUT Specifications and Requirements:	5
3.6	Cables:	5
3.7	Power Requirements:	5
3.8	Typical Installation and/or Operating Environment:	5
3.9	Other Special Requirements:	5
3.10	EUT Software:	5
3.11	EUT System Components	6
3.12	Support Equipment	6
3.13	Deviations from Standard:	6
3.14	General Remarks:	6
3.15	Summary:	6
4.0	Test Set-Up Drawings and Photos	7
4.1	Test Set-up Photo, Radiated Emissions	7
4.2	Test Set-up Drawings	8
5.0	Test Results	10
5.1.1	27.50 RF Power Limits	10
5.1.2	27.54 Frequency Stability	11
5.1.3	27.53 Emission Limitations	12
6.0	Test Equipment	13
7.0	Appendix A	14
7.1	Conducted Emission Limits Test	15
7.2	Conducted Output Power Test	31
7.3	Frequency Stability Test	32
7.4	Intermodulation Test	34
7.5	Occupied Bandwidth Modulation Test	63
8.0	Appendix B	70
9.0	Appendix C	72



2.0 REVISION DESCRIPTION

Rev	Total Pages	Date	Description
A	72	30 January, 2012	Original Release

3.0 DOCUMENTATION

3.1 Test Regulations

27.50	Power limits
27.53	Emission limits
27.54	Frequency stability

The emissions tests were performed according to the following regulations:

- FCC Part 90
- FCC Part 24

Environmental Conditions in the lab:

ADC

Temperature: 24° C
Relative Humidity: 21%
Atmospheric Pressure: 98.8 kPa

Intertek

15-35° C
30-60%
86-106 kPa

Power Supply Utilized:

Power Supply System : 1 phase, 60 Hz, 120 VAC

3.2 Test Operation Mode

- Standby
- Test Program
- Practice Operation

■ Max composite in and out

3.3 Configuration of the Device Under Test:

Normal Operation – 800 – 851 to 869 MHz
Normal Operation – PCS – 1930 to 1990 MHz

3.4 Product Options:

None

3.5 EUT Specifications and Requirements:

Length: 11.50"
Width: 9.00"
Height: 3.50"
Weight: 7.49 pounds

3.6 Cables:

Cable Type	Length	From	To
RF	> 3M	Ancillary Equip	EUT
RF	< 3M	EUT	50 Ohm Load
Power (2)	< 3M	Power	Input Power (Ancillary)
Coax (75 Ohm)	> 3M	Ancillary Equip	EUT

3.7 Power Requirements:

Voltage: 54 VDC

3.8 Typical Installation and/or Operating Environment:

Indoor. System is typically employed as an indoor repeater.

3.9 Other Special Requirements:

None

3.10 EUT Software:

Revision Level: Version V.6 or greater
Description: Internet Explorer

3.11 EUT System Components

Description	Model #	Serial #	FCC ID #
Prism Host Unit	FWP-0000HUII	None	
Spectrum DRU	SPT-0000DRUII	None	
Spectrum IFEU	742735-0	None	
Spectrum Power Supply	LTPCPR1U3C-Z-527		
Remote Access Unit	<u>SPT-S1-8019-22</u>	None	

3.12 Support Equipment

Description	Manufacturer	Model #	FCC ID #
Power Meter	HP	437B	
Signal Generator	Agilent	8648C	

3.13 Deviations from Standard:

Modifications required to pass:

As indicated on the data sheet(s)

■ **None**

Test Specification Deviations; Additions to or Exclusions from:

As indicated in the Test Plan

■ **None**

3.14 General Remarks:

None.

3.15 Summary:

The requirements according to the technical regulations are

■ **met**

not Met

The equipment under test does

■ **fulfill the general approval requirements mentioned in Section 3.1.**

not fulfill the general approval requirements mentioned in Section 3.1.

4.0 TEST SET-UP DRAWINGS AND PHOTOS

[Table of Contents; Section 1.0](#)

4.1 Test Set-up Photo, Radiated Emissions

Reference Document Name: **100616112MIN-001**

Test Engineer: Richard Blonigen

Date: January 23, 2012

4.2 Test Set-up Drawings

Conducted and Radiated Emission Limits Test

Conducted Output Power Test

Inter-Modulation Test

Occupied Bandwidth Modulation Test

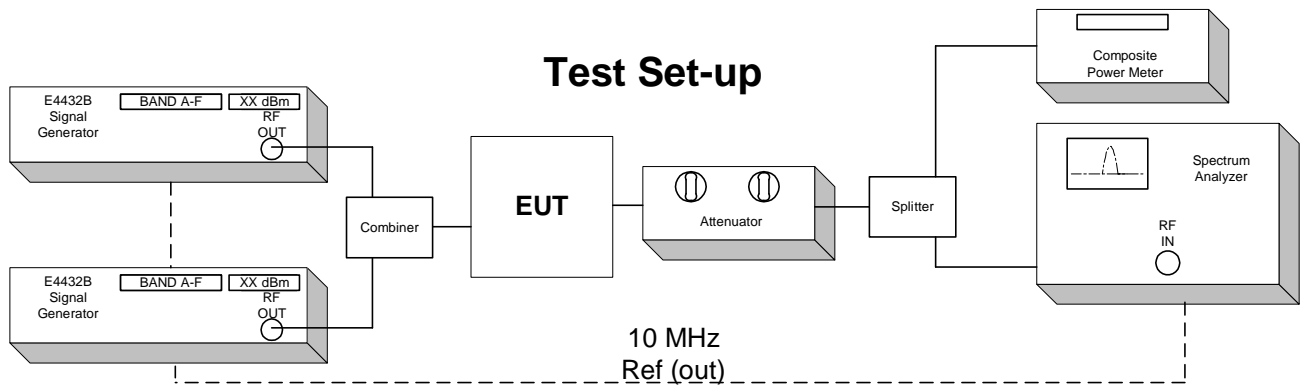

Frequency Tolerance Test

The Host, DRU, and IFEU EUT are specified for indoor use with temperature range of 0° to +50° C, and were tested within their range.

The Remote Access Unit EUT is specified for indoor use with temperature range of -25° to +50° C, and was tested with its range.

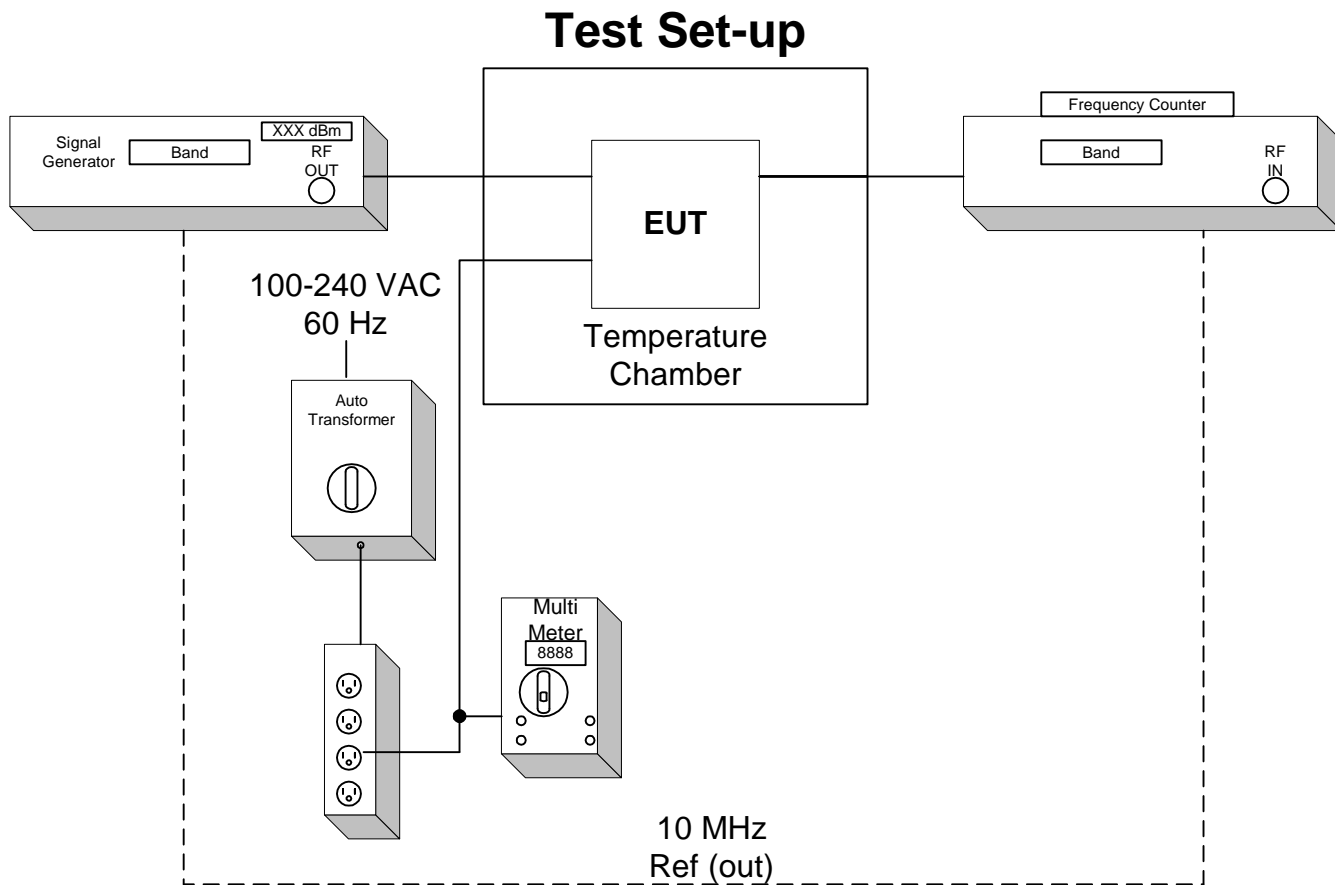

5.0 TEST RESULTS

5.1.1 27.50 RF Power Limits

Test Summary:

- The requirements are: **MET** NOT MET
- Minimum margin of compliance is 19.74 dB at 851.04 MHz (iDEN)
- Minimum margin of compliance is 26.95 dB at 851.04 MHz (APCO 25 C4FM)
- Minimum margin of compliance is 23.23 dB at 1960 MHz (CDMA)
- Minimum margin of compliance is 27.08 dB at 1960 MHz (GSM)
- Minimum margin of compliance is 25.20 dB at 1960 MHz (EDGE)
- Minimum margin of compliance is 18.29 dB at 1960 MHz (W-CDMA)

Test Location:

INTERTEK (Oakdale, MN)

ADC facility (Shakopee, MN)

Test Distance:

3 Meters

10 Meters

Conducted measurement

Test Equipment (ADC):

1, 2, 6, 7, 12

Test Limit:

100 Watts or 50 dBm Limit

Test Data:

[Conducted Output Power; Section 7.2](#)

Test Engineer: Joshua J. Wittman

Date: 25 May, 2011

12 October, 2011

[Table of Contents; Section 1.0](#)

5.1.2 27.54 Frequency Stability

Test Summary:

- The requirements are: **MET** NOT MET
- The fundamental emission stays within the limit.
- Frequency measured over a temperature range of -25 to 50° C and an input voltage range of 100 to 240 VAC.

Test Location:

INTERTEK (Oakdale, MN)

ADC facility (Shakopee, MN)

Test Equipment (ADC):

3, 4, 5, 6, 9,11,12

Test Limit:

The frequency stability shall be sufficient to ensure that the fundamental emission stays within the authorized frequency block.

Test Data:

[Frequency Stability; Section 7.3](#)

Test Engineer: Joshua J. Wittman

Date: 25 May, 2011

12 October, 2011

[Table of Contents; Section 1.0](#)

5.1.3 27.53 Emission Limitations

Test Summary:

- The requirements are: **MET** NOT MET
- Out of band emissions were less than -13 dBm.
- Outside the emission bandwidth of the carrier, all emissions are attenuated at least 26 dB below the transmitter power.

Test Location:

INTERTEK (Oakdale, MN)

ADC facility (Shakopee, MN)

Test Equipment (ADC):

1, 2, 6, 7, 12, 13

Test Limit:

Out of band emissions:

Attenuated below the transmitting power (P) by a factor of at least $43 + 10\log(P)$ dB, or -13 dBm.

Outside of the carrier emissions bandwidth:

26 dB below the transmitter power

Test Data:

[Conducted Emissions; Section 7.1](#)

[Intermodulation; Section 7.4](#)

[Occupied Bandwidth; Section 7.5](#)

Radiated Emissions; ([Appendix B](#))

[Table of Contents; Section 1.0](#)

Test Engineer: Joshua J. Wittman

Date: 25 May, 2011

13 October, 2011

9 November, 2011

6.0 TEST EQUIPMENT

[Table of Contents; Section 1.0](#)

Number	Description	Manufacturer	Model	ADC TELECOMMUNICATIONS Serial Number	Cal Due	Used
1	Spectrum Analyzer	HP	8563E	MC27690	3-15-12	<input checked="" type="checkbox"/>
2	Power Meter	HP	437B	MC27541	6-30-12	<input checked="" type="checkbox"/>
3	Multimeter	Fluke	79	MC18758	6-30-13	<input checked="" type="checkbox"/>
4	Frequency Counter	HP	5347A	MC27548	7-27-12	<input checked="" type="checkbox"/>
5	Temperature Chamber	ESPEC	PSL-4G	MC10075	9-8-12	<input checked="" type="checkbox"/>
6	Signal Generator	Aeroflex	3413	MC57343	11-9-12	<input checked="" type="checkbox"/>
7	Signal Generator	Aeroflex	3413	MC57947	4-15-12	<input checked="" type="checkbox"/>
8	Variable Auto Transformer	Staco	1520CT	MC44655	CNR	<input checked="" type="checkbox"/>
9	Digital Barometer	Fisher Scientific	02-403	MC50719	1-20-12	<input checked="" type="checkbox"/>
10	Attenuator	Aeroflex	49-30-33	N/A	CNR	<input checked="" type="checkbox"/>
11	Attenuator	Aeroflex	86-30-12	N/A	CNR	<input checked="" type="checkbox"/>
12	RF Power Sensor	HP	8482A	MC27649	6-30-12	<input checked="" type="checkbox"/>
13	Spectrum Analyzer	Rhode & Schwarz	FSQ-8	MC57131	11-15-11	13

Equipment with a Calibration Not Required (CNR) listing is verified and compensated for with NIST traceable calibrated equipment.

7.0

APPENDIX A

Conducted Emissions Test Data

[Table of Contents; Section 1.0](#)

Test Engineer: Joshua J. Wittman

7.1 Conducted Emission Limits Test

[Table of Contents; Section 1.0](#)

[Back to Emission Limits; Section 5.1.3](#)

The out of band emissions were measured directly from the EUT antenna output in the TX path using a spectrum analyzer from 30 MHz to the 10th harmonic of the highest carrier frequency. Test signals used are iDEN, APCO 25 C4FM, CDMA, GSM, EDGE, & WCDMA. The different signals were input one at a time to the EUT. In all cases, the out of band emissions were less than -13 dBm from the equation

$$(19\text{dBm} - [43 + 10\log(0.08\text{W})])$$

Band edge compliance is also demonstrated using a CDMA, GSM, EDGE, & WCDMA signal at the upper and lower limits of the band.

The Prism Host, Spectrum DRU, and Spectrum IFEU are Part 15 devices and have been tested and are compliant as such.

Industry practice has generally set the input signal power level. Test signal used was \approx -11 dBm input to Prism Host in the TX Path.

Industry practice has generally set the output signal power level.

Prism Host:	Spectrum DRU:	Spectrum IFEU	Remote Access Unit(RAU):
Range: 21 - 60 VDC	Range: 21 - 60 VDC	Range: 54 VDC	Range: 54 VDC
Tested @: 54 VDC	Tested @: 54 VDC	Tested @: 54 VDC	Tested @: 54 VDC

Application details for 2.1033(c)(10), and 2.1033(c)(13):

Final RF Amplifier Input DC Voltage and Current: 7.3V at 400mA

PLL creates all the Local Oscillators that convert signal to IF and RF signals. When PLL is unlocked the band is shut down, this is to avoid transmission of any incorrect frequency.

Internal to the electronics, the use of SAW filters provides for higher Q roll-off at band edges.

This equipment does not modulate the RF, so there is no modulation limiter. This equipment does not change the modulation of the RF or the occupied bandwidth of any channel. It transports the signal, as is, over TV (IF) coax cable. The RF input is not changed in the RF output.

This is a constant gain device, so the setup controls the output. There is an overdrive and overpower limit control that prevents excess power.

Results:

Pass (See plots)

Conducted Emissions
Center: 860 MHz

APCO 25 C4FM
Span: 5 MHz

Spectrum 800 MHz SMR
RBW/VBW: 100 kHz

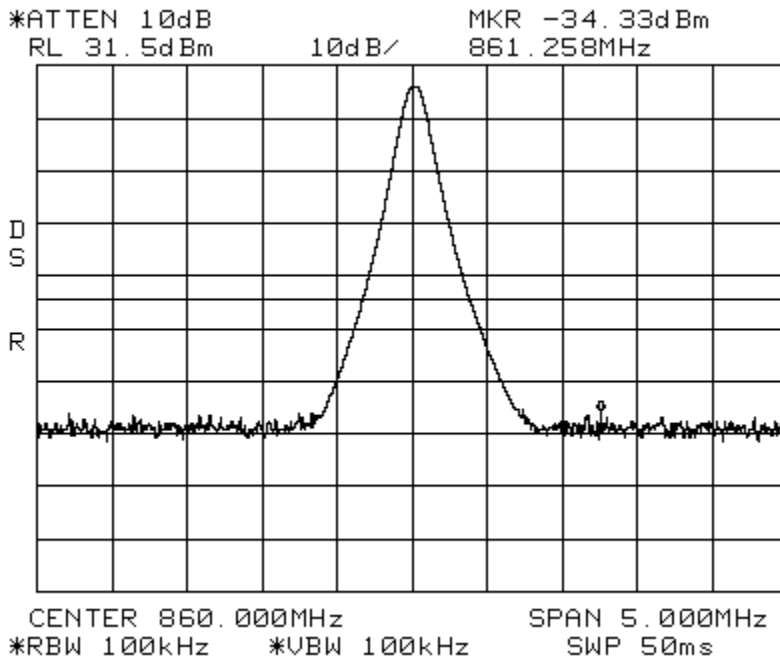

Conducted Emissions
Span: 30 MHz to 1 GHz

APCO 25 C4FM

Spectrum 800 MHz SMR
RBW/VBW: 300 kHz

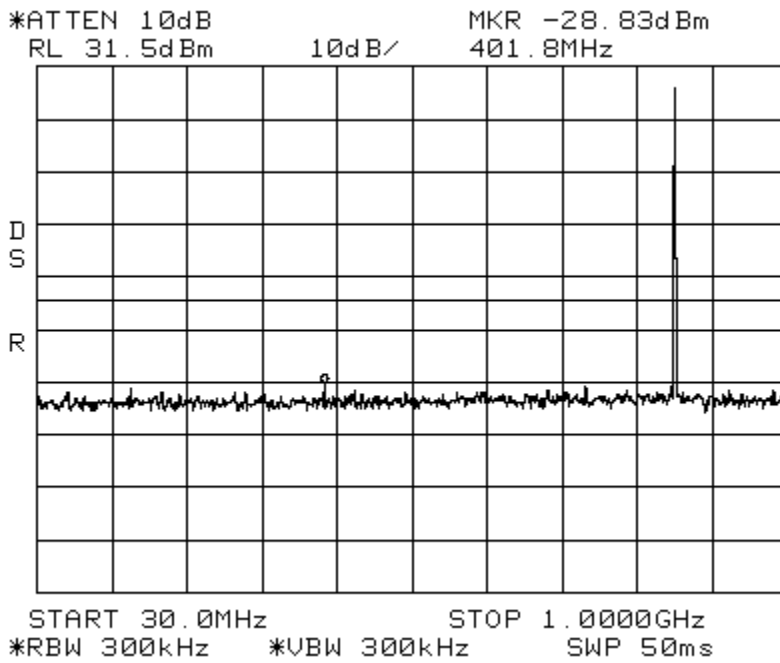

Conducted Emissions

APCO 25 C4FM

Spectrum 800 MHz SMR

Span: 1 GHz to 10 GHz

RBW/VBW: 1 MHz

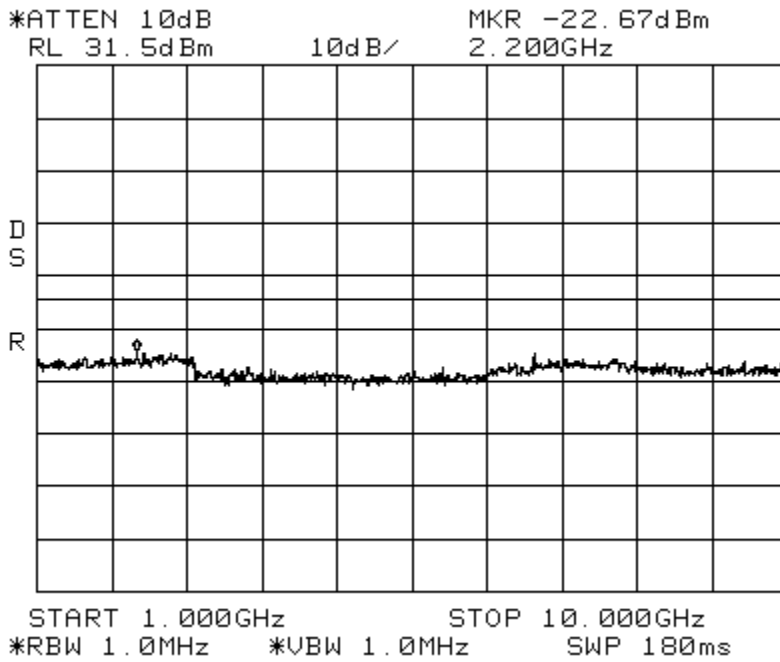

Conducted Emissions
Center: 860 MHz

iDEN
Span: 5 MHz

Spectrum 800 MHz SMR
RBW/VBW: 100 kHz

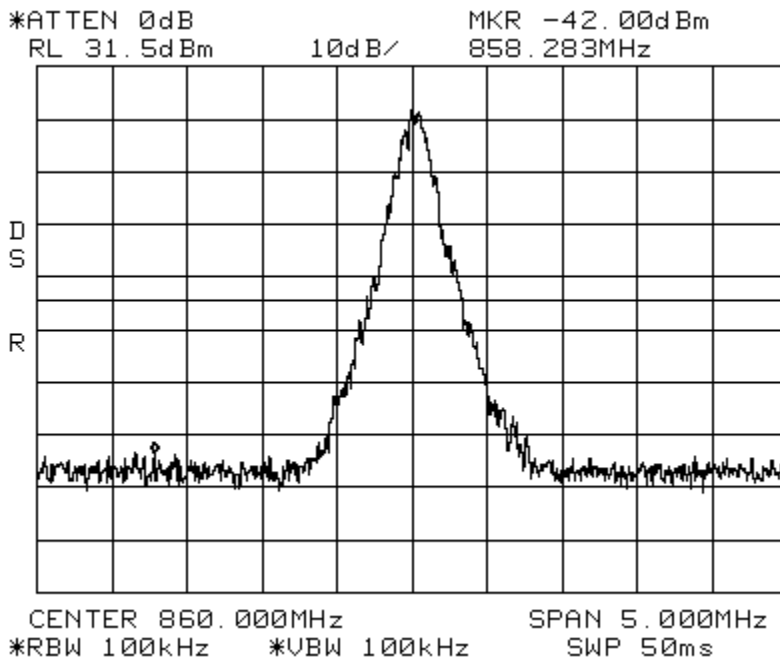

Conducted Emissions iDEN
Span: 30 MHz to 1 GHz

Spectrum 800 MHz SMR
RBW/VBW: 300 kHz

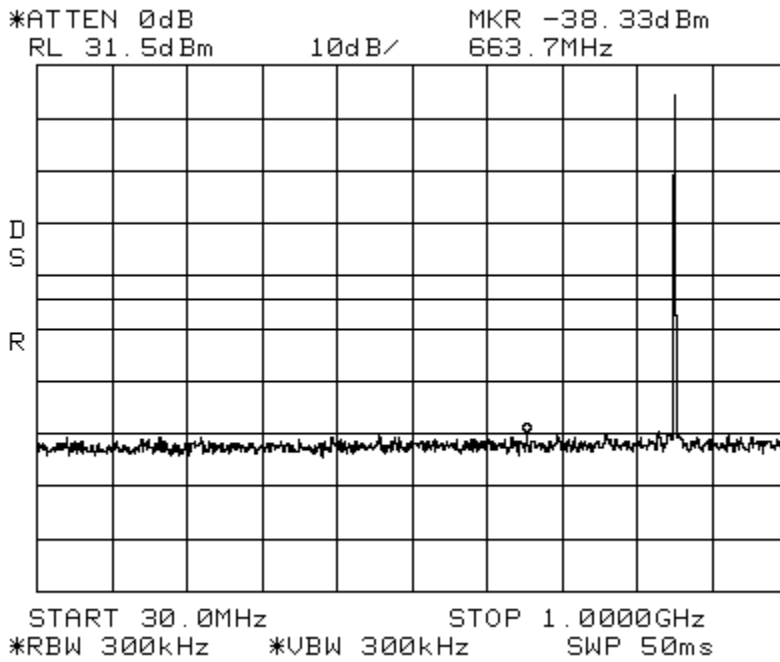

Conducted Emissions iDEN
Span: 1 GHz to 10 GHz

Spectrum 800 MHz SMR
RBW/VBW: 1 MHz

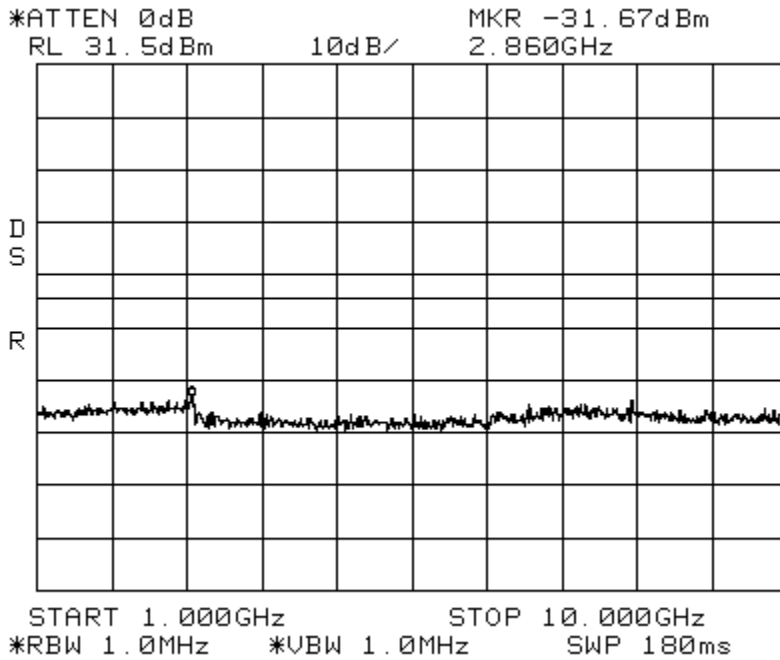

Conducted Emissions CDMA
Center: 1960 MHz Span: 5 MHz

Spectrum PCS Path 2
RBW/VBW: 100 kHz

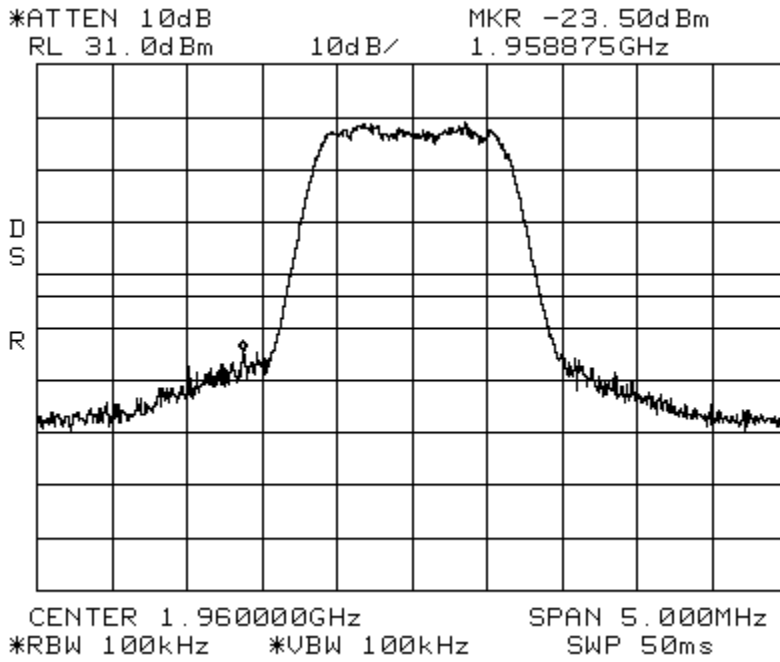

Conducted Emissions
Span: 30 MHz to 1 GHz

CDMA Spectrum PCS Path 2
RBW/VBW: 300 kHz

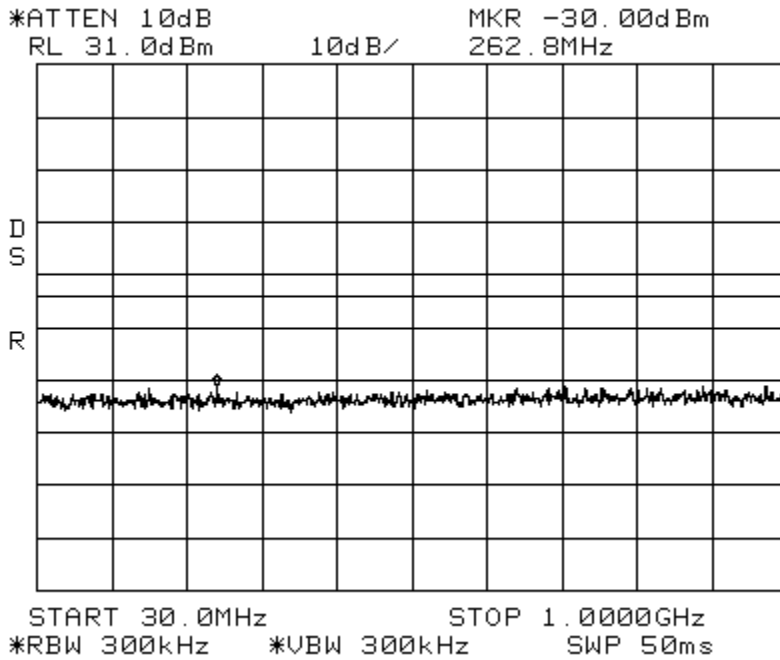

Conducted Emissions
Span: 1 GHz to 20 GHz

CDMA

Spectrum PCS Path 2
RBW/VBW: 1 MHz

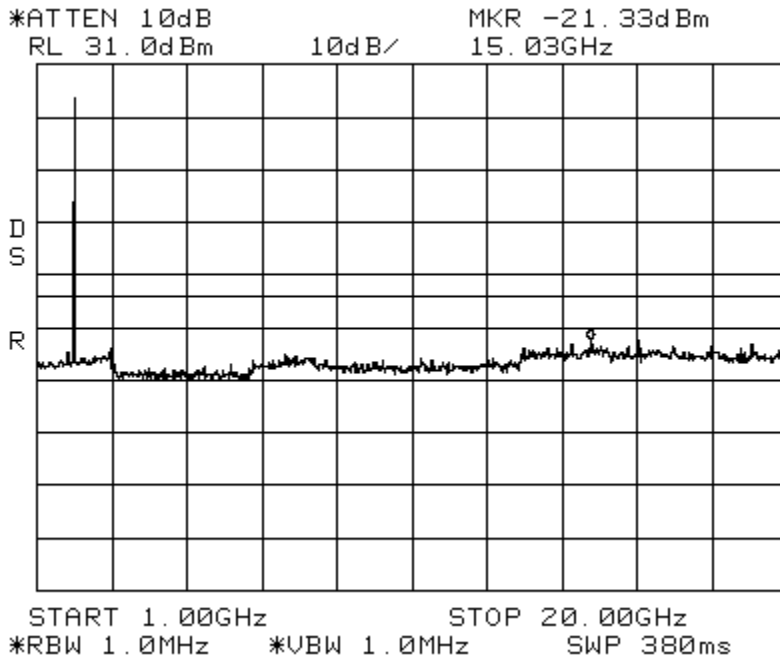

Conducted Emissions
Center: 1960 MHz

EDGE
Span: 5 MHz

Spectrum PCS Path 2
RBW/VBW: 100 kHz

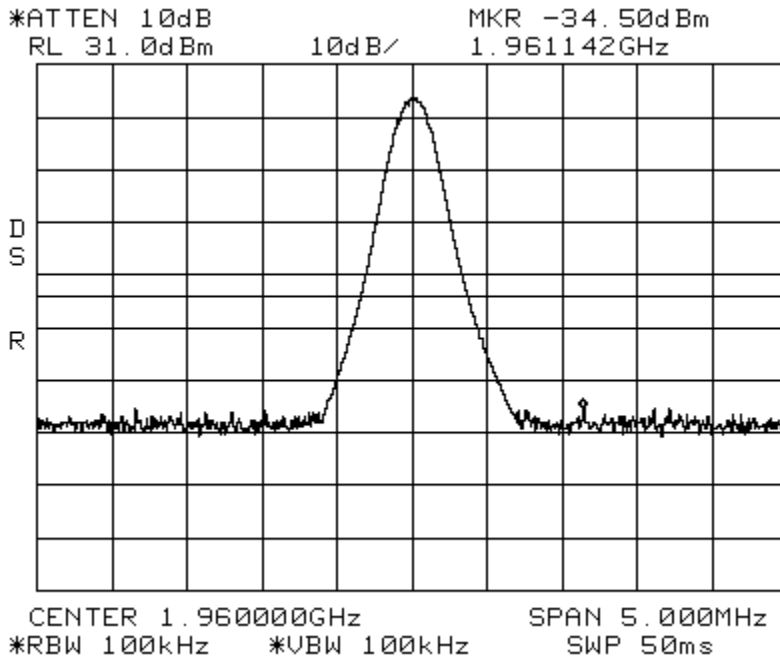

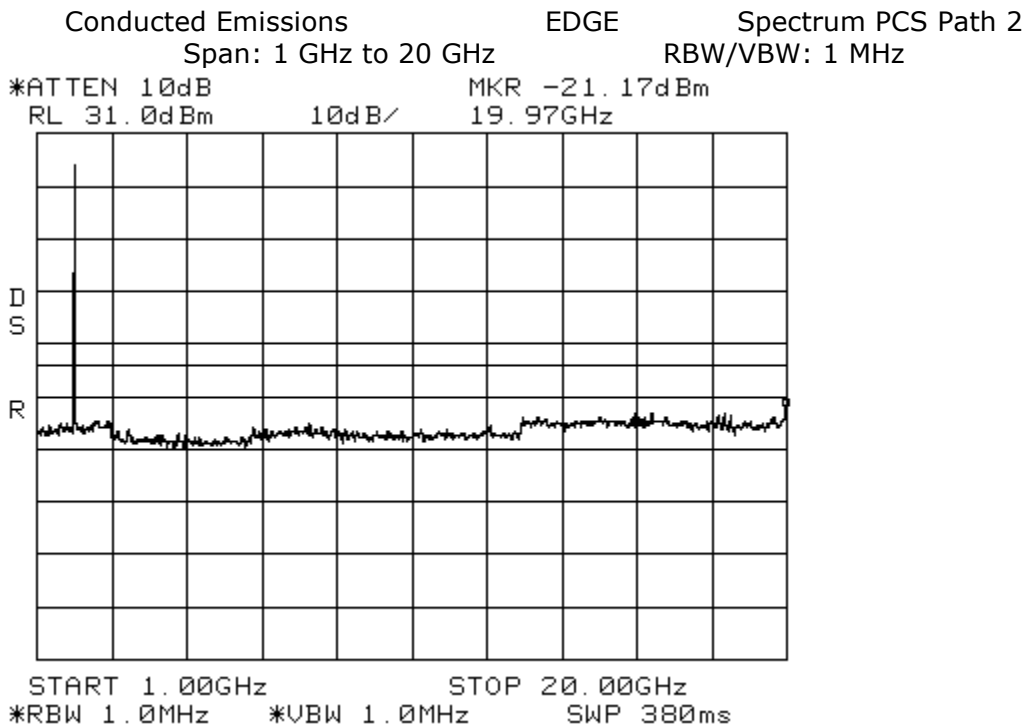
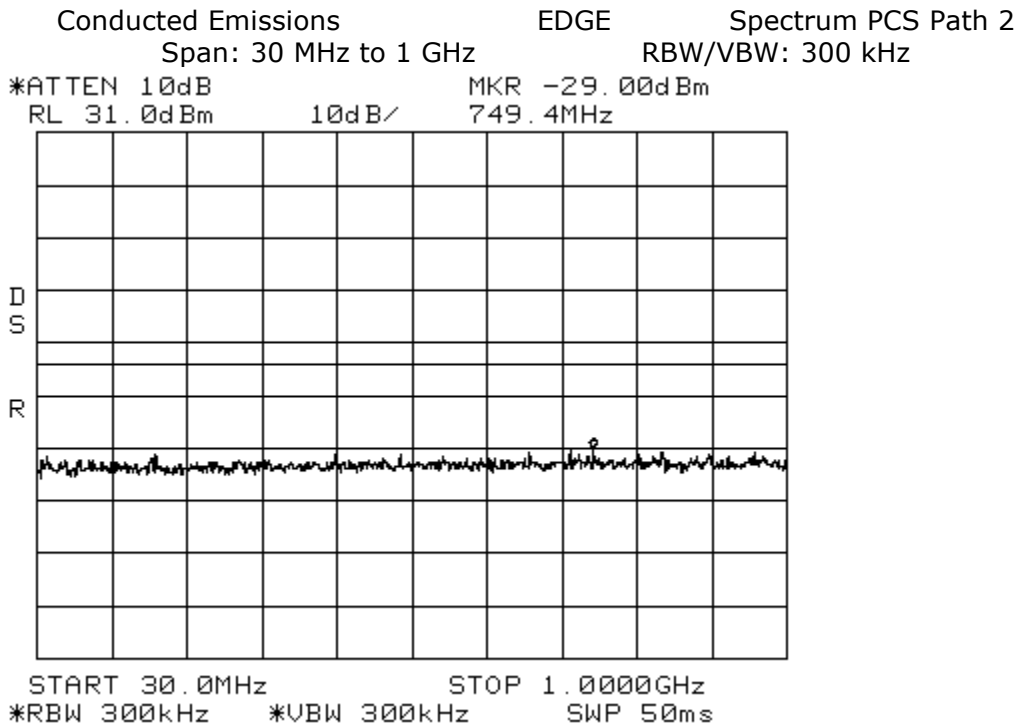

Conducted Emissions
Center: 1960 MHz

GSM
Span: 5 MHz

Spectrum PCS Path 2
RBW/VBW: 100 kHz

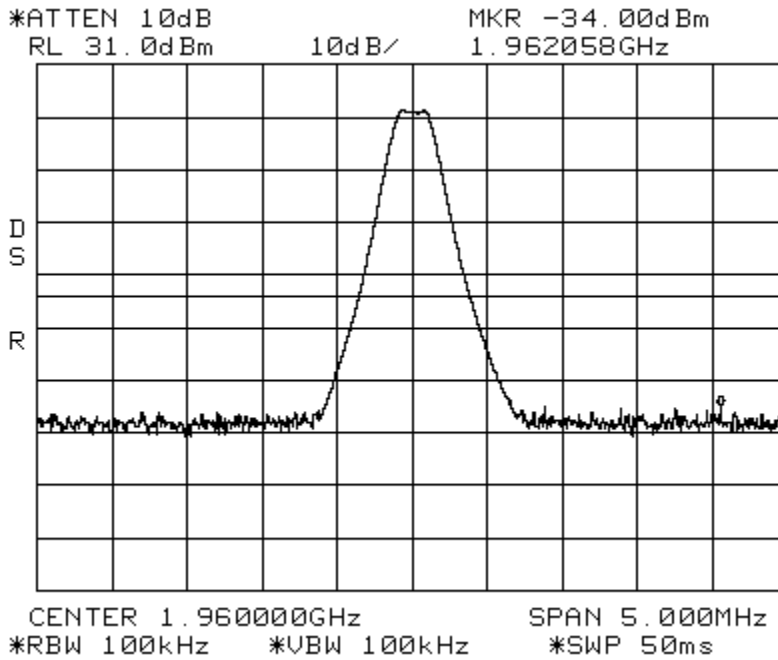

Conducted Emissions
Span: 30 MHz to 1 GHz

GSM

Spectrum PCS Path 2
RBW/VBW: 300 kHz

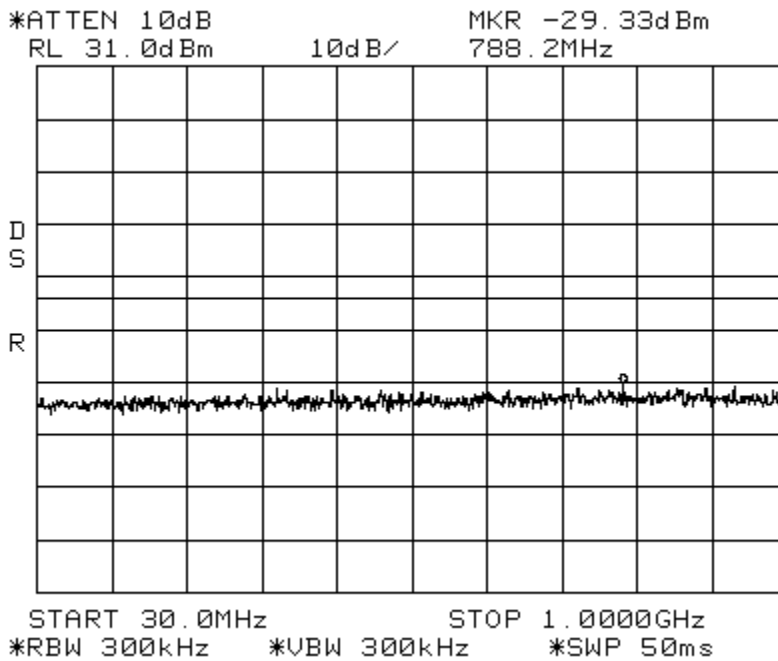

Conducted Emissions
Span: 1 GHz to 20 GHz

GSM

Spectrum PCS Path 2
RBW/VBW: 1 MHz

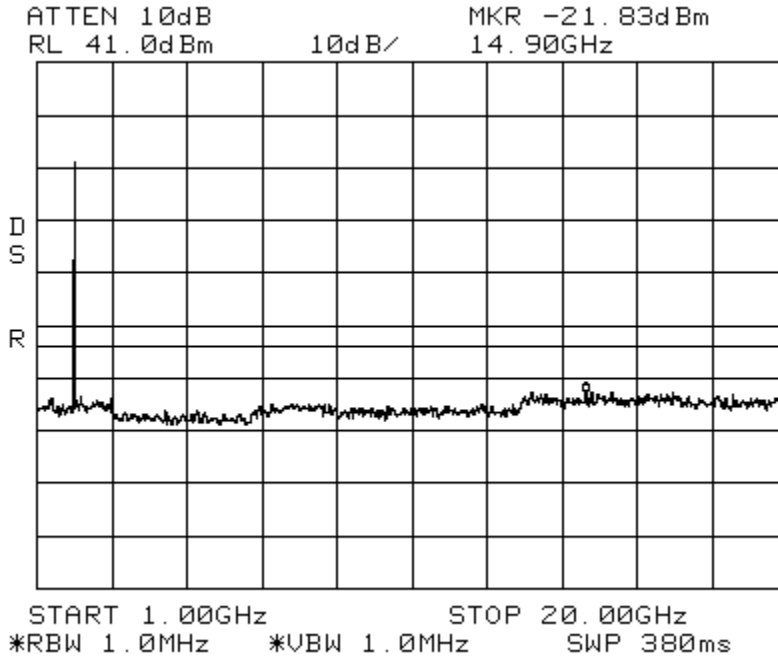

Conducted Emissions
Center: 1960 MHz

WCDMA
Span: 10 MHz

Spectrum PCS Path 2
RBW/VBW: 100 kHz

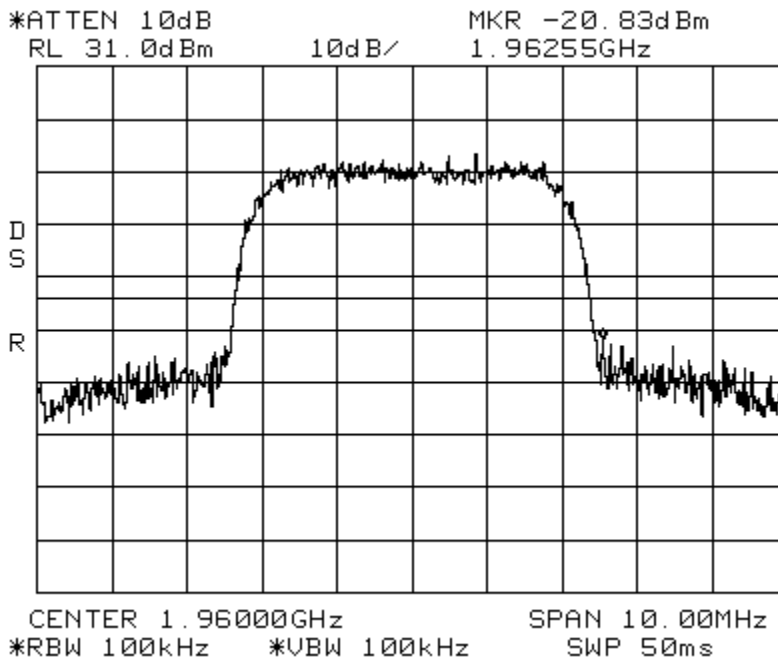

Conducted Emissions
Span: 30 MHz to 1 GHz

WCDMA

Spectrum PCS Path 2
RBW/VBW: 300 kHz

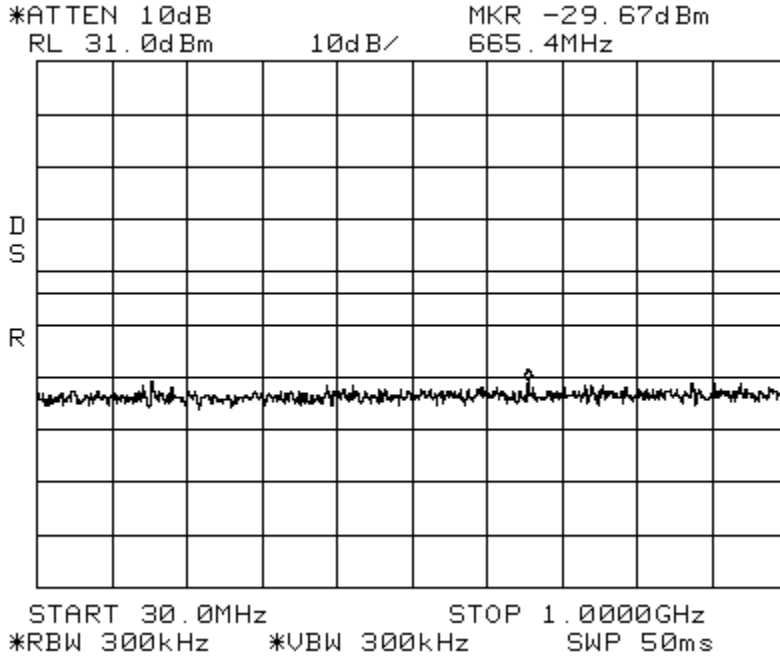

Conducted Emissions
Span: 1 GHz to 20 GHz

WCDMA

Spectrum PCS Path 2
RBW/VBW: 1 MHz

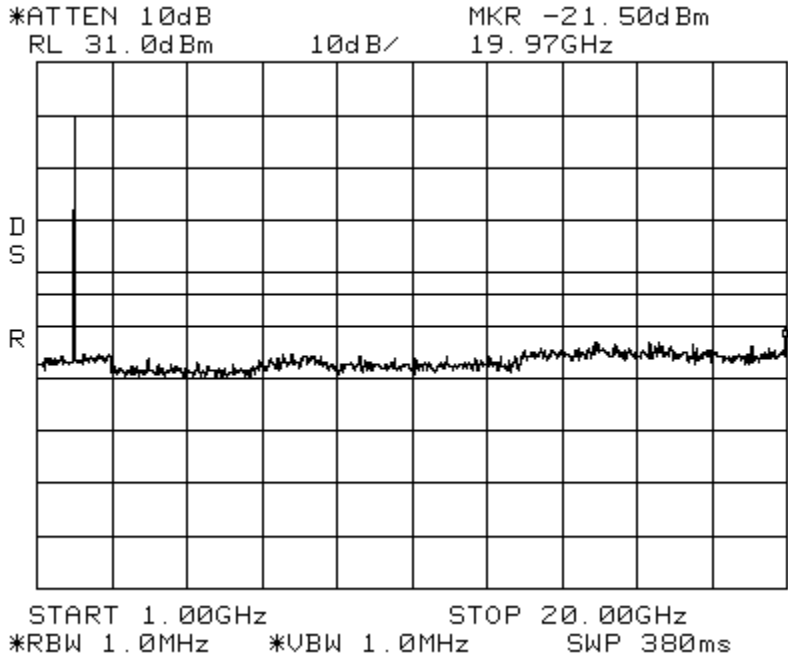

Band_Edge APCO 25 C4FM Spectrum 800 SMR
Center: 851.04 MHz Span: 2 MHz RBW: 3 kHz VBW: 10 kHz

*ATTEN 20dB MKR -33.67dBm
RL 41.0dBm 10dB/ 851.000MHz

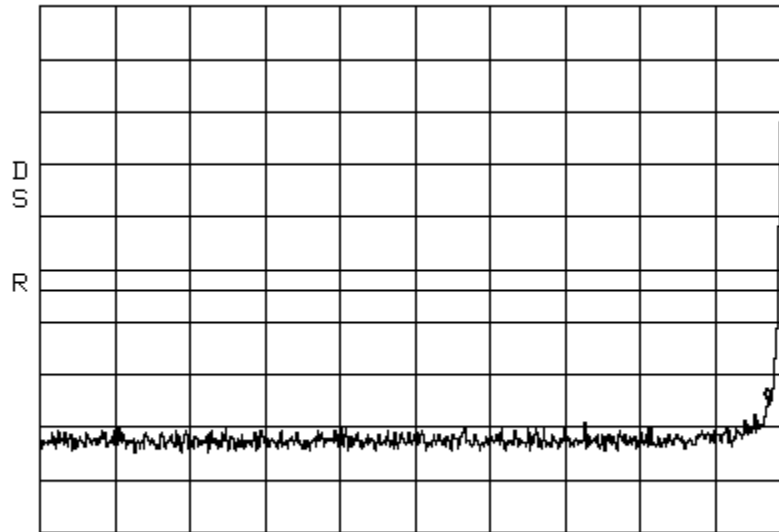

CENTER 850.060MHz SPAN 2.000MHz
*RBW 3.0kHz *VBW 10kHz *SWP 2.0sec

Band_Edge APCO 25 C4FM Spectrum 800 SMR
Center: 868.96 MHz Span: 2 MHz RBW: 3 kHz VBW: 10 kHz

*ATTEN 20dB MKR -35.50dBm
RL 41.0dBm 10dB/ 869.000MHz

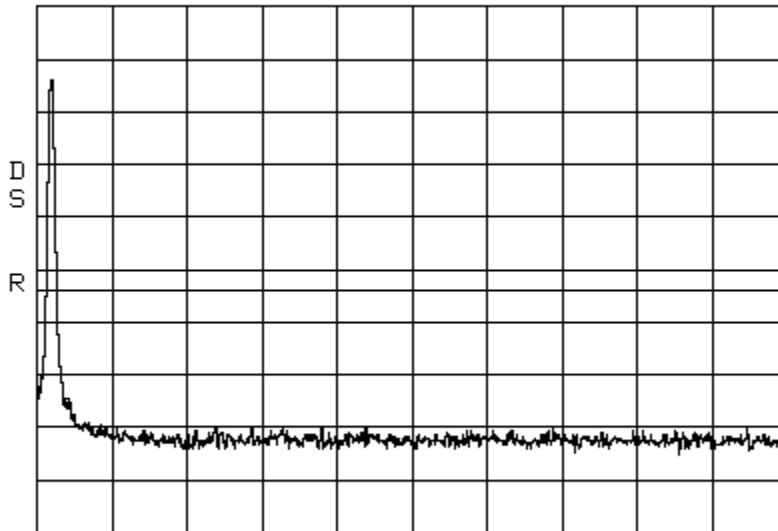

CENTER 869.920MHz SPAN 2.000MHz
*RBW 3.0kHz *VBW 10kHz *SWP 2.0sec

Band_Edge iDEN Spectrum 800 SMR
Center: 851.04 MHz Span: 2 MHz RBW: 1 kHz VBW: 1 kHz

*ATTEN 20dB MKR -32.67dBm
RL 41.0dBm 10dB/ 851.000MHz

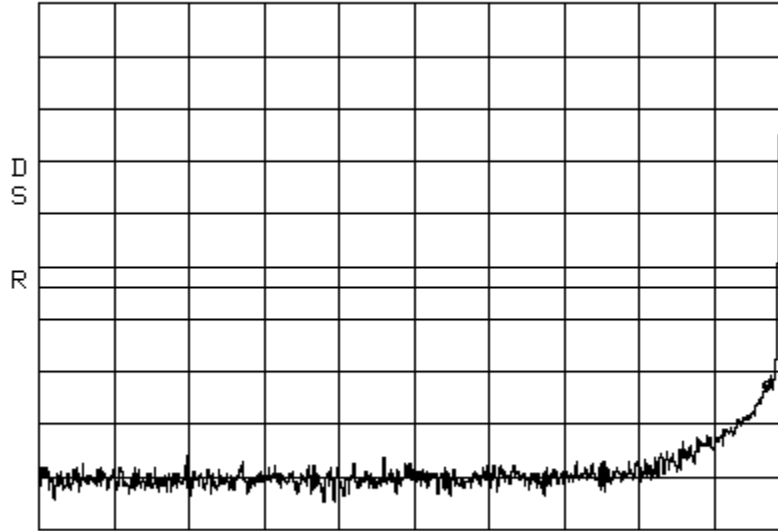

CENTER 850.060MHz SPAN 2.000MHz
*RBW 1.0kHz *VBW 1.0kHz *SWP 5.0sec

Band_Edge iDEN Spectrum 800 SMR
Center: 868.96 MHz Span: 2 MHz RBW: 1 kHz VBW: 1 kHz

*ATTEN 20dB MKR -27.83dBm
RL 41.0dBm 10dB/ 869.000MHz

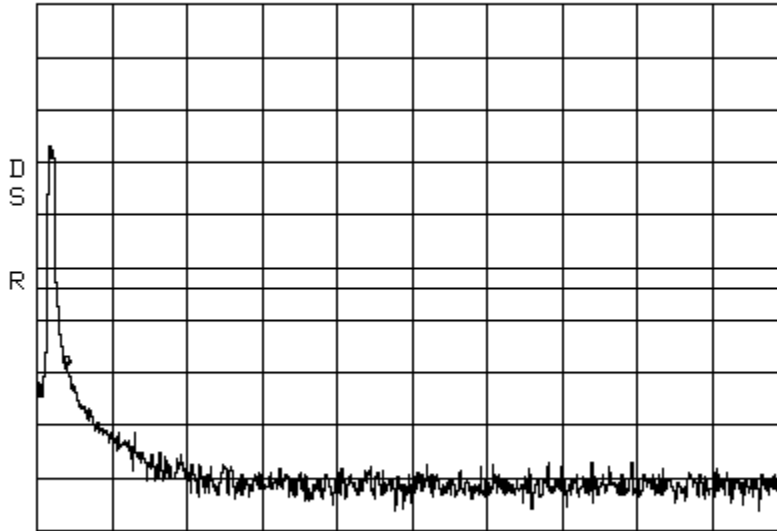

CENTER 869.920MHz SPAN 2.000MHz
*RBW 1.0kHz *VBW 1.0kHz *SWP 5.0sec

Band_Edge CDMA Spectrum PCS Path 2
Center: 1930.75 MHz Span: 2 MHz RBW: 10 kHz VBW: 10 kHz

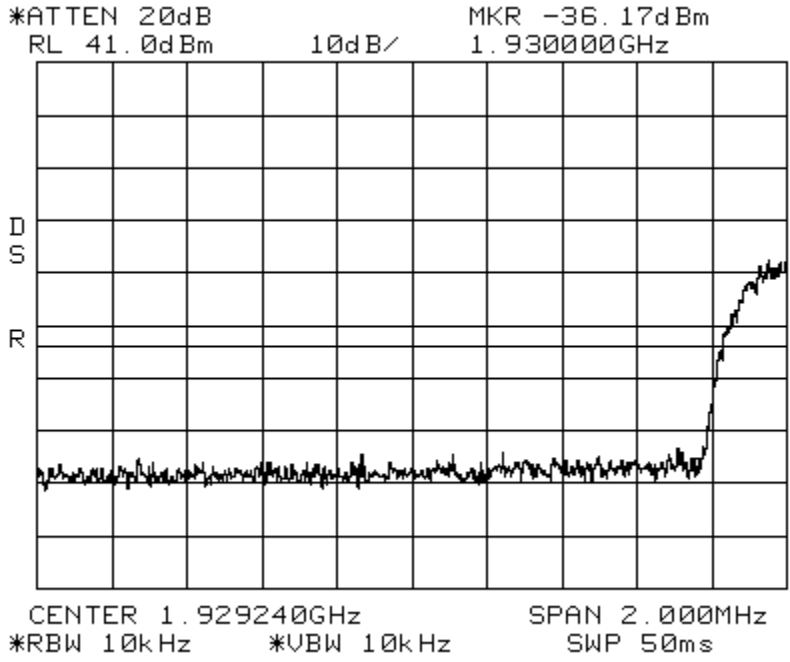

Band_Edge CDMA Spectrum PCS Path 2
Center: 1989.25 MHz Span: 2 MHz RBW: 10 kHz VBW: 10 kHz

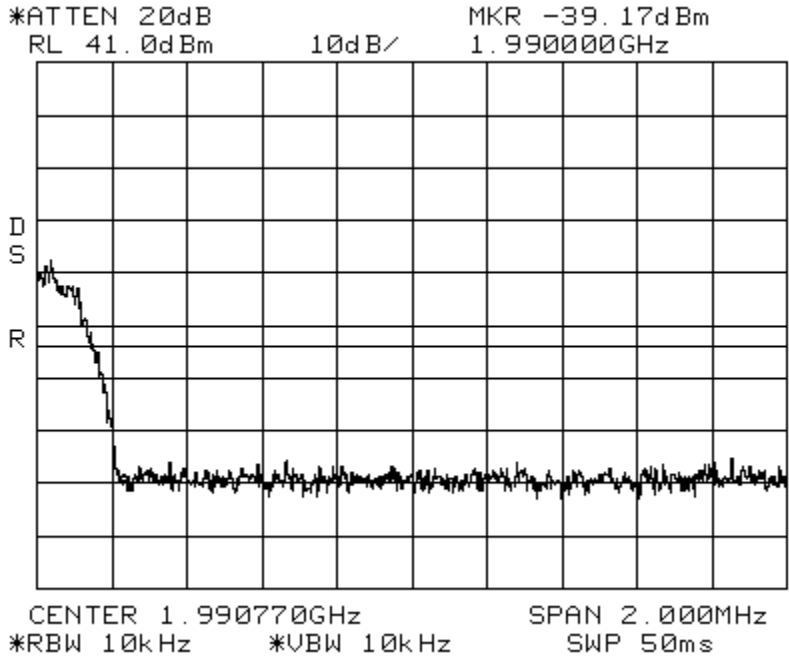

Band_Edge EDGE Spectrum PCS Path 2
 Center: 1930.2 MHz Span: 2 MHz RBW: 3 kHz VBW: 10 kHz
 *ATTEN 20dB MKR -25.83dBm
 RL 41.0dBm 10dB/ 1.929977GHz

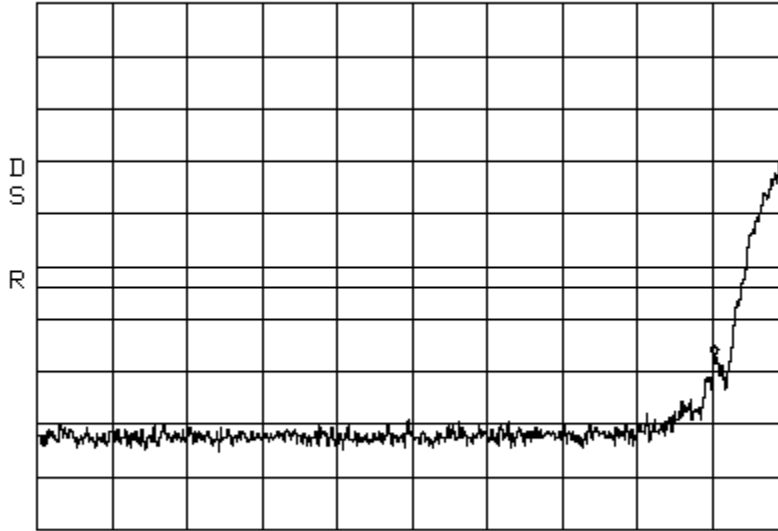

CENTER 1.929170GHz SPAN 2.000MHz
 *RBW 3.0kHz *VBW 10kHz SWP 560ms

Band_Edge EDGE Spectrum PCS Path 2
 Center: 1989.8 MHz Span: 2 MHz RBW: 3 kHz VBW: 10 kHz

*ATTEN 20dB MKR -25.67dBm
 RL 41.0dBm 10dB/ 1.990020GHz

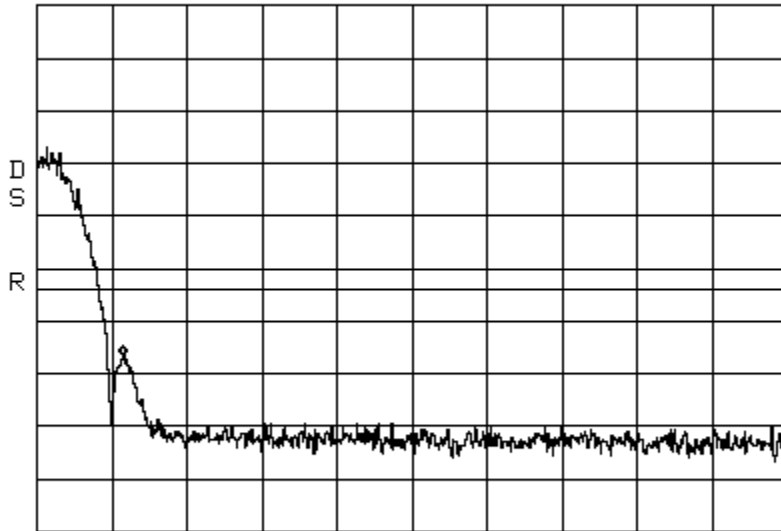

CENTER 1.990790GHz SPAN 2.000MHz
 *RBW 3.0kHz *VBW 10kHz SWP 560ms

Band_Edge GSM
Center: 1930.2 MHz Span: 2 MHz

Spectrum PCS Path 2
RBW: 3 kHz VBW: 10 kHz

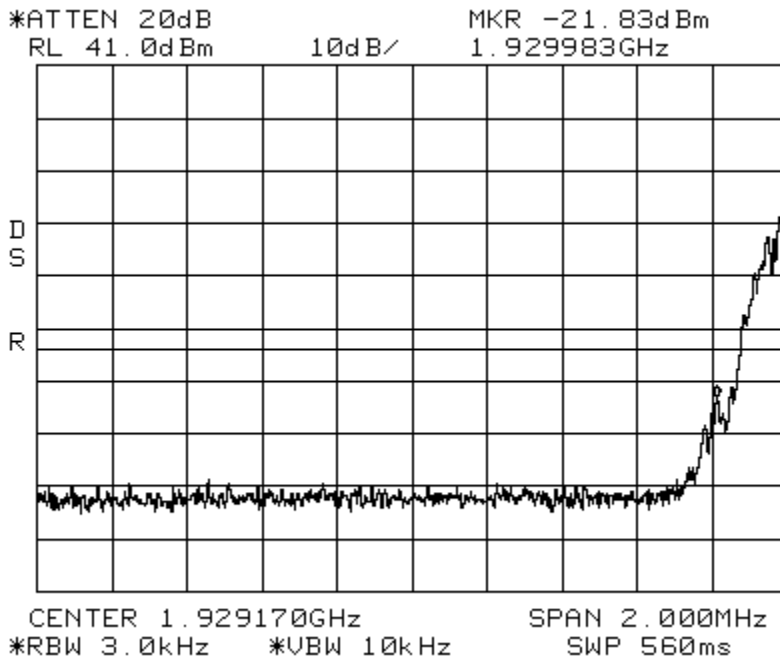

Band_Edge GSM
Center: 1989.8 MHz Span: 2 MHz

Spectrum PCS Path 2
RBW: 3 kHz VBW: 10 kHz

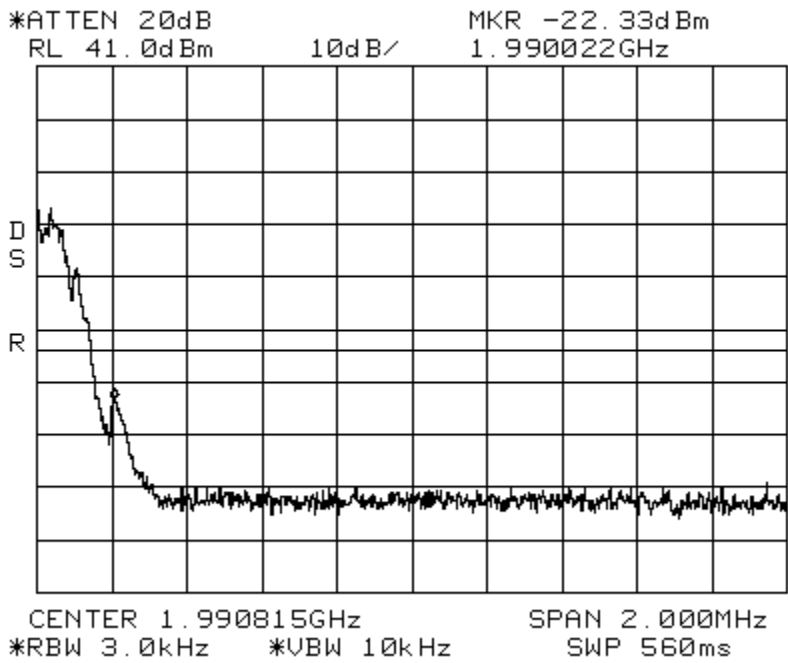

Band_Edge WCDMA
Center: 1932.5 MHz Span: 2 MHz

Spectrum PCS Path 2
RBW: 30 kHz VBW: 100 kHz

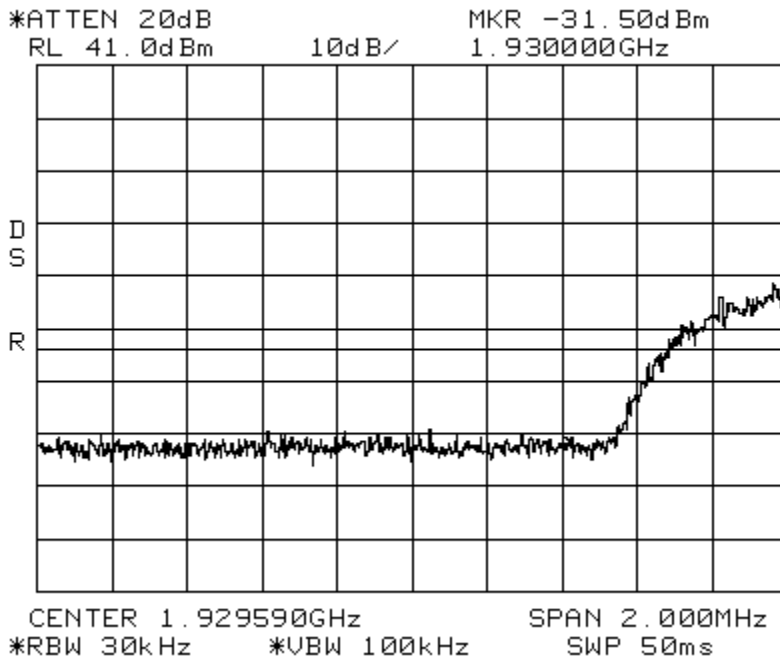

Band_Edge WCDMA
Center: 1987.5 MHz Span: 2 MHz

Spectrum PCS Path 2
RBW: 30 kHz VBW: 100 kHz

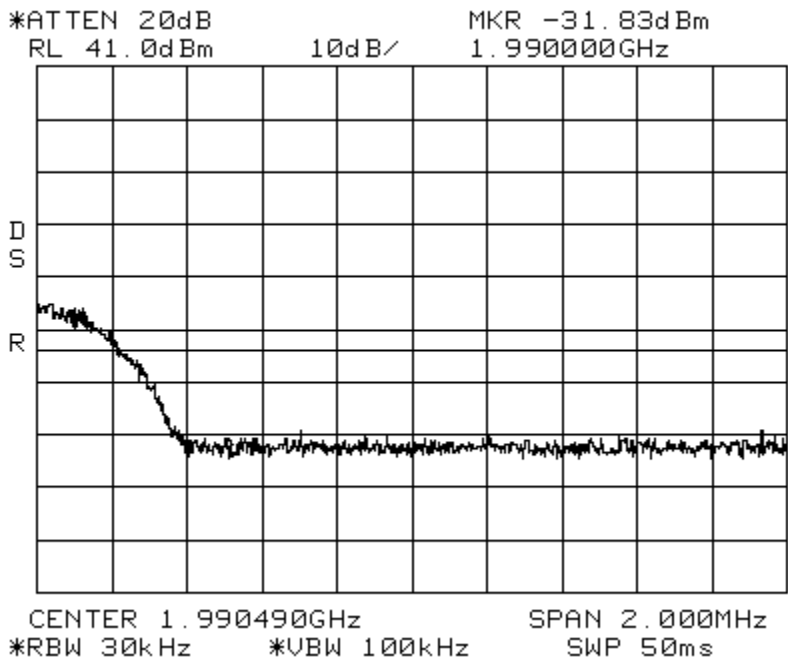

7.2 Conducted Output Power Test

[Table of Contents; Section 1.0](#)

[Back to Conducted Output Power; Section 5.1.1](#)

*Note: The EUT is a fixed repeater and not a base station.

This measurement was made as a direct conducted emission measurement. The output from the EUT antenna connector was connected to the power meter. The carrier output, below, was conducted using a single iDEN, APCO 25 C4FM, CDMA, GSM, EDGE, & WCDMA signal generator. The power meter level was offset to compensate for attenuators and cable loss between the EUT and the power meter.

A signal was used at the low, mid and high parts of the selected band.

800 Path 2

iDEN **0.09418 Watts**

Carrier Frequency	Carrier Output
851.04 MHz	<u>19.74</u> dBm
860.00 MHz	<u>18.56</u> dBm
868.96 MHz	<u>18.78</u> dBm

800 Path 2

APCO 25 C4FM **0.49545 Watts**

Carrier Frequency	Carrier Output
851.04 MHz	<u>26.95</u> dBm
860.00 MHz	<u>26.75</u> dBm
868.96 MHz	<u>26.73</u> dBm

PCS Path 2

CDMA **0.2103 Watts**

Carrier Frequency	Carrier Output
1930.8 MHz	<u>19.55</u> dBm
1960.0 MHz	<u>23.23</u> dBm
1989.2 MHz	<u>19.56</u> dBm

PCS Path 2

GSM **0.5105 Watts**

Carrier Frequency	Carrier Output
1930.2 MHz	<u>24.11</u> dBm
1960.0 MHz	<u>27.08</u> dBm
1989.8 MHz	<u>24.80</u> dBm

PCS Path 2

EDGE **0.3311 Watts**

Carrier Frequency	Carrier Output
1930.2 MHz	<u>21.33</u> dBm
1960.0 MHz	<u>25.20</u> dBm
1989.8 MHz	<u>22.22</u> dBm

PCS Path 2

WCDMA **0.0674 Watts**

Carrier Frequency	Carrier Output
1932.5 MHz	<u>15.25</u> dBm
1960.0 MHz	<u>18.29</u> dBm
1987.5 MHz	<u>14.40</u> dBm

7.3 Frequency Stability Test

[Table of Contents; Section 1.0](#)
[Back to Frequency Stability; Section 5.1.1](#)

Host/DRU	IFEU	RAU	Carrier Frequency	Measured Frequency	Meets Requirements?
Input Voltage	Input Voltage	Input Voltage			
100 VAC	54VDC	54 VDC	851.200 MHz	851.200 MHz	Yes
170 VAC	54VDC	54 VDC	851.200 MHz	851.200 MHz	Yes
240 VAC	54VDC	54 VDC	851.200 MHz	851.200 MHz	Yes
100 VAC	54VDC	54 VDC	860.000 MHz	860.000 MHz	Yes
170 VAC	54VDC	54 VDC	860.000 MHz	860.000 MHz	Yes
240 VAC	54VDC	54 VDC	860.000 MHz	860.000 MHz	Yes
100 VAC	54VDC	54 VDC	868.800 MHz	868.800 MHz	Yes
170 VAC	54VDC	54 VDC	868.800 MHz	868.800 MHz	Yes
240 VAC	54VDC	54 VDC	868.800 MHz	868.800 MHz	Yes
Temperature			Carrier Frequency	Measured Frequency	Meets Requirements?
-25 Deg. C			851.200 MHz	851.200 MHz	Yes
-20 Deg. C			851.200 MHz	851.200 MHz	Yes
-10 Deg. C			851.200 MHz	851.200 MHz	Yes
0 Deg. C			851.200 MHz	851.200 MHz	Yes
10 Deg. C			851.200 MHz	851.200 MHz	Yes
20 Deg. C			851.200 MHz	851.200 MHz	Yes
30 Deg. C			851.200 MHz	851.200 MHz	Yes
40 Deg. C			851.200 MHz	851.200 MHz	Yes
45 Deg. C			851.200 MHz	851.200 MHz	Yes
50 Deg. C			851.200 MHz	851.200 MHz	Yes
-25 Deg. C			860.000 MHz	860.000 MHz	Yes
-20 Deg. C			860.000 MHz	860.000 MHz	Yes
-10 Deg. C			860.000 MHz	860.000 MHz	Yes
0 Deg. C			860.000 MHz	860.000 MHz	Yes
10 Deg. C			860.000 MHz	860.000 MHz	Yes
20 Deg. C			860.000 MHz	860.000 MHz	Yes
30 Deg. C			860.000 MHz	860.000 MHz	Yes
40 Deg. C			860.000 MHz	860.000 MHz	Yes
45 Deg. C			860.000 MHz	860.000 MHz	Yes
50 Deg. C			860.000 MHz	860.000 MHz	Yes
-25 Deg. C			868.800 MHz	868.800 MHz	Yes
-20 Deg. C			868.800 MHz	868.800 MHz	Yes
-10 Deg. C			868.800 MHz	868.800 MHz	Yes
0 Deg. C			868.800 MHz	868.800 MHz	Yes
10 Deg. C			868.800 MHz	868.800 MHz	Yes
20 Deg. C			868.800 MHz	868.800 MHz	Yes
30 Deg. C			868.800 MHz	868.800 MHz	Yes
40 Deg. C			868.800 MHz	868.800 MHz	Yes
45 Deg. C			868.800 MHz	868.800 MHz	Yes
50 Deg. C			868.800 MHz	868.800 MHz	Yes

Host/DRU	IFEU	RAU			
Input Voltage	Input Voltage	Input Voltage	Carrier Frequency	Measured Frequency	Meets Requirements?
100 VAC	54VDC	54 VDC	1930.200 MHz	1930.200 MHz	Yes
170 VAC	54VDC	54 VDC	1930.200 MHz	1930.200 MHz	Yes
240 VAC	54VDC	54 VDC	1930.200 MHz	1930.200 MHz	Yes
100 VAC	54VDC	54 VDC	1960.000 MHz	1960.000 MHz	Yes
170 VAC	54VDC	54 VDC	1960.000 MHz	1960.000 MHz	Yes
240 VAC	54VDC	54 VDC	1960.000 MHz	1960.000 MHz	Yes
100 VAC	54VDC	54 VDC	1989.800 MHz	1989.800 MHz	Yes
170 VAC	54VDC	54 VDC	1989.800 MHz	1989.800 MHz	Yes
240 VAC	54VDC	54 VDC	1989.800 MHz	1989.800 MHz	Yes
Temperature			Carrier Frequency	Measured Frequency	Meets Requirements?
-25 Deg. C			1930.200 MHz	1930.200 MHz	Yes
-20 Deg. C			1930.200 MHz	1930.200 MHz	Yes
-10 Deg. C			1930.200 MHz	1930.200 MHz	Yes
0 Deg. C			1930.200 MHz	1930.200 MHz	Yes
10 Deg. C			1930.200 MHz	1930.200 MHz	Yes
20 Deg. C			1930.200 MHz	1930.200 MHz	Yes
30 Deg. C			1930.200 MHz	1930.200 MHz	Yes
40 Deg. C			1930.200 MHz	1930.200 MHz	Yes
45 Deg. C			1930.200 MHz	1930.200 MHz	Yes
50 Deg. C			1930.200 MHz	1930.200 MHz	Yes
-25 Deg. C			1960.000 MHz	1960.000 MHz	Yes
-20 Deg. C			1960.000 MHz	1960.000 MHz	Yes
-10 Deg. C			1960.000 MHz	1960.000 MHz	Yes
0 Deg. C			1960.000 MHz	1960.000 MHz	Yes
10 Deg. C			1960.000 MHz	1960.000 MHz	Yes
20 Deg. C			1960.000 MHz	1960.000 MHz	Yes
30 Deg. C			1960.000 MHz	1960.000 MHz	Yes
40 Deg. C			1960.000 MHz	1960.000 MHz	Yes
45 Deg. C			1960.000 MHz	1960.000 MHz	Yes
50 Deg. C			1960.000 MHz	1960.000 MHz	Yes
-25 Deg. C			1989.800 MHz	1989.800 MHz	Yes
-20 Deg. C			1989.800 MHz	1989.800 MHz	Yes
-10 Deg. C			1989.800 MHz	1989.800 MHz	Yes
0 Deg. C			1989.800 MHz	1989.800 MHz	Yes
10 Deg. C			1989.800 MHz	1989.800 MHz	Yes
20 Deg. C			1989.800 MHz	1989.800 MHz	Yes
30 Deg. C			1989.800 MHz	1989.800 MHz	Yes
40 Deg. C			1989.800 MHz	1989.800 MHz	Yes
45 Deg. C			1989.800 MHz	1989.800 MHz	Yes
50 Deg. C			1989.800 MHz	1989.800 MHz	Yes

7.4 Intermodulation Test

[Table of Contents; Section 1.0](#)

[Back to Emission Limits; Section 5.1.3](#)

The inter-modulation products test was performed for the EUT. Three tests were performed with the modulation type. Test 1 was with 2 signals input to the EUT at lower end channels. Test 2 was with 2 signals input to the EUT at upper end channels. Test 3 was with 2 signals input to the EUT at upper and lower end channels. The modulation types tested were iDEN, APCO 25 C4FM, CDMA, GSM, EDGE, & WCDMA. An investigation was made from 30 MHz to the 10th Harmonic of the highest fundamental frequency (~20 GHz). The following plots show the results.

Results:
(See Plots)

Intermodulation
Center: 860 MHz

APCO 25 C4FM_Low Spectrum 800 MHz SMR
Span: 25 MHz RBW/VBW: 100 kHz

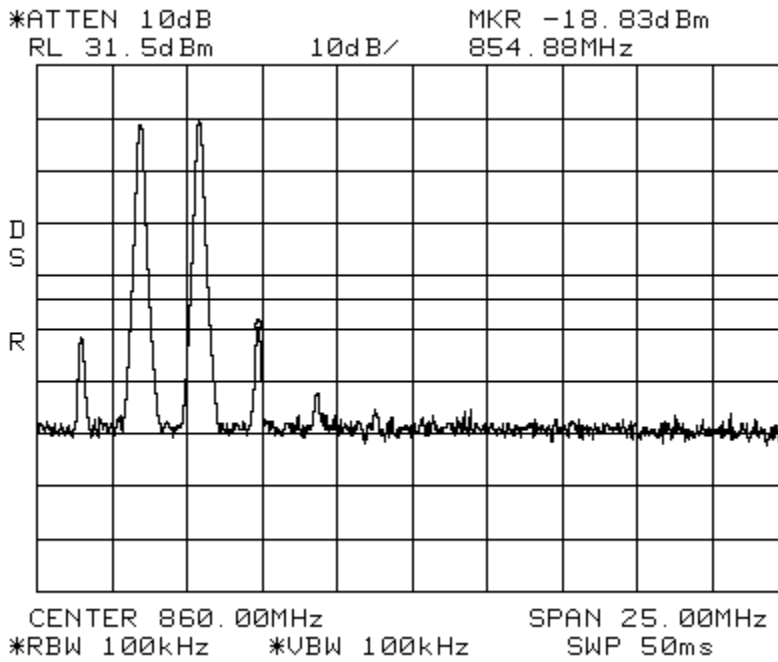

Intermodulation APCO 25 C4FM_Low Spectrum 800 MHz SMR
Span: 30 MHz to 1 GHz RBW/VBW: 300 kHz

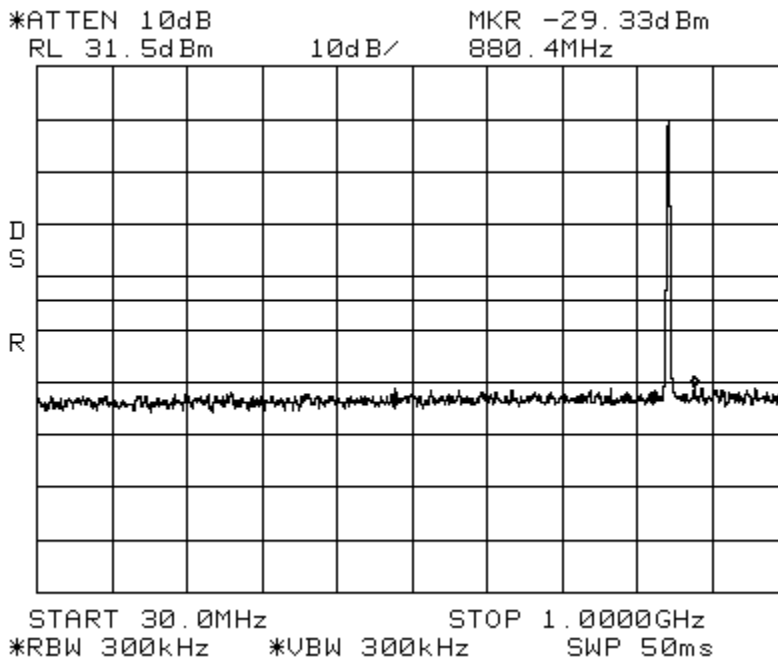

Intermodulation

APCO 25 C4FM _Low Spectrum 800 MHz SMR

Span: 1 GHz to 10 GHz

RBW/VBW: 1 MHz

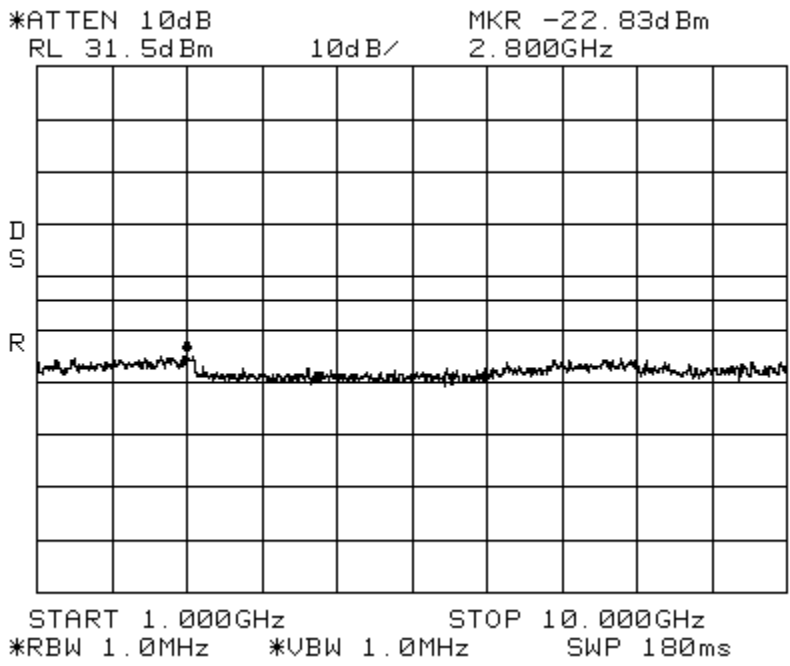

Intermodulation

APCO 25 C4FM _High

Spectrum 800 MHz SMR

Center: 860 MHz

Span: 25 MHz

RBW/VBW: 100 kHz

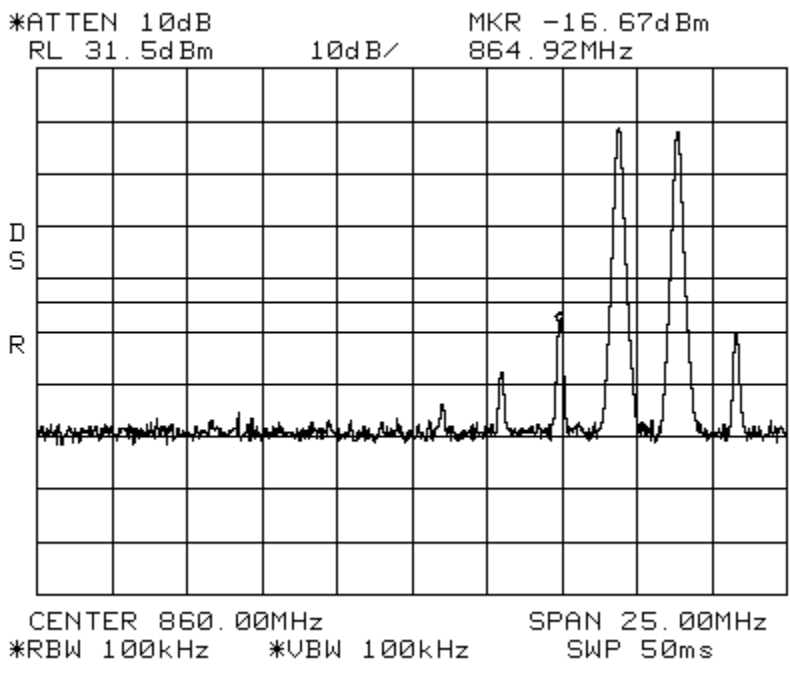

Intermodulation

APCO 25 C4FM_High Spectrum 800 MHz SMR

Span: 30 MHz to 1 GHz

RBW/VBW: 300 kHz

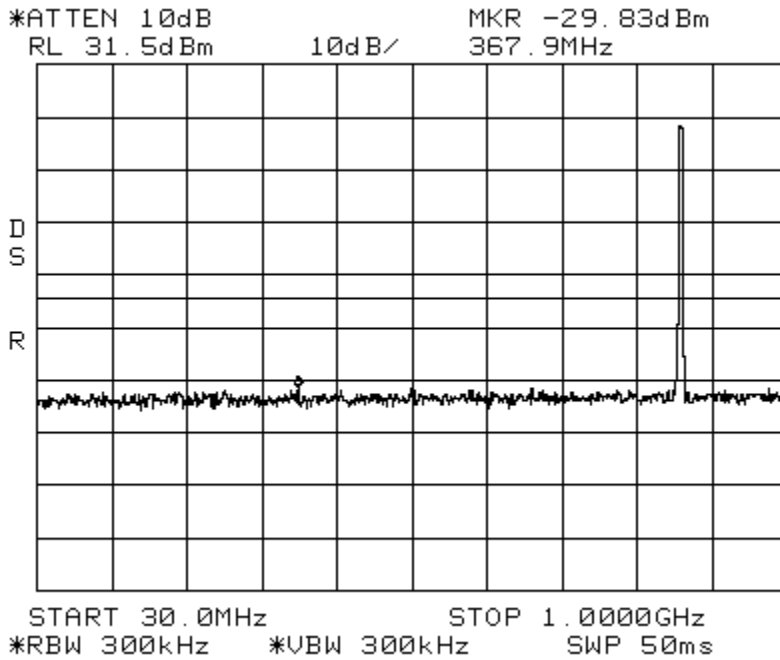

Intermodulation

APCO 25 C4FM_HighSpectrum 800 MHz SMR

Span: 1 GHz to 10 GHz

RBW/VBW: 1 MHz

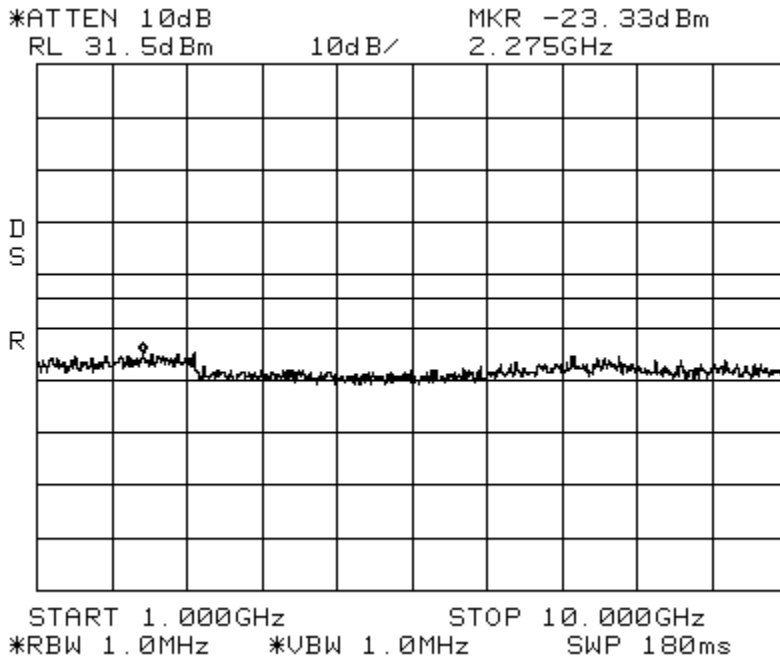

Intermodulation

APCO 25 C4FM_Apart

Spectrum 800 MHz SMR

Center: 860 MHz

Span: 75 MHz

RBW/VBW: 100 kHz

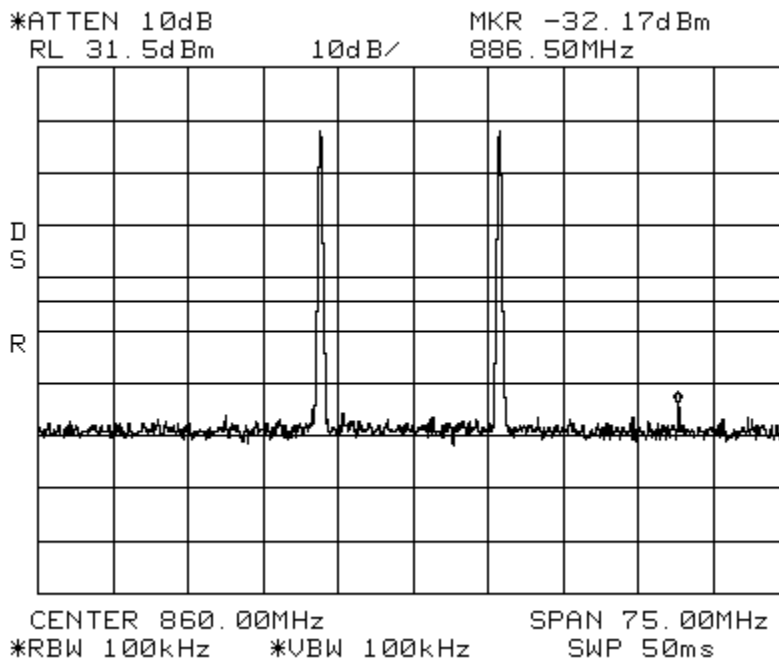

Intermodulation

APCO 25 C4FM_Apart

Spectrum 800 MHz SMR

Span: 30 MHz to 1 GHz

RBW/VBW: 300 kHz

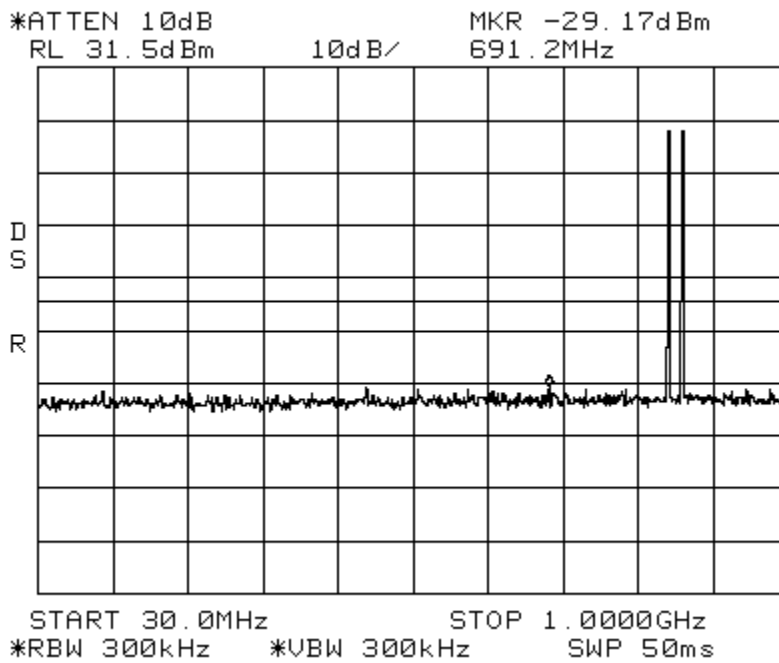

Intermodulation

APCO 25 C4FM _Apart

Spectrum 800 MHz SMR

Span: 1 GHz to 10 GHz

RBW/VBW: 1 MHz

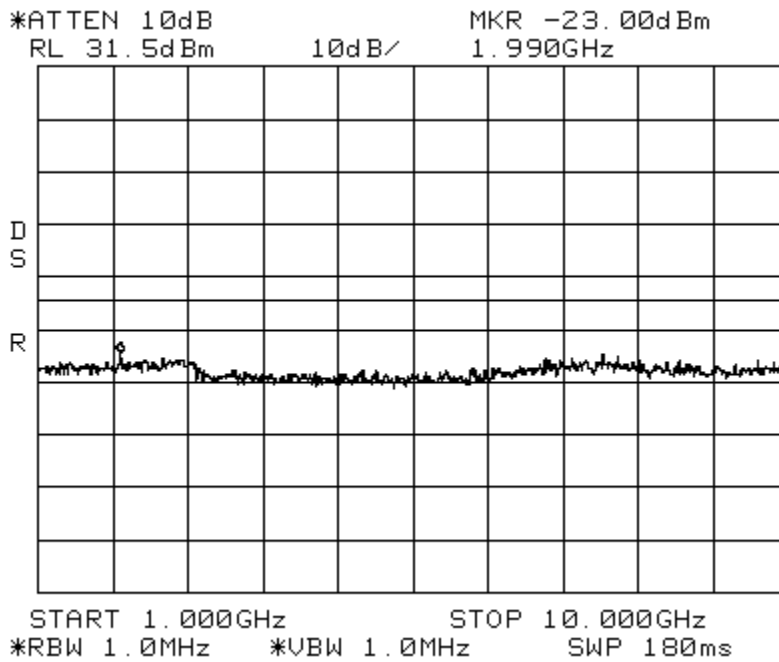

Intermodulation
Center: 860 MHz

iDEN_Low
Span: 25 MHz

Spectrum 800 MHz SMR
RBW/VBW: 100 kHz

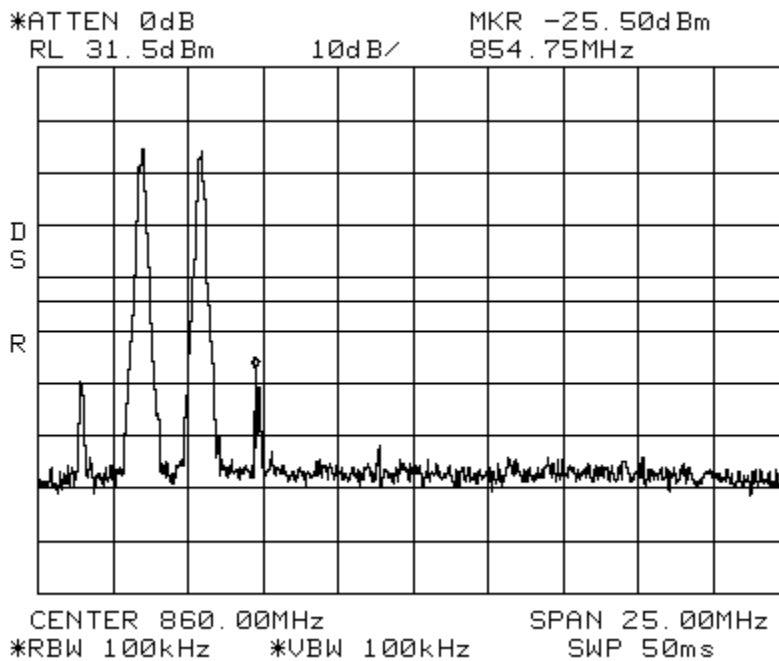

Intermodulation iDEN_Low Spectrum 800 MHz SMR
Span: 30 MHz to 1 GHz RBW/VBW: 300 kHz

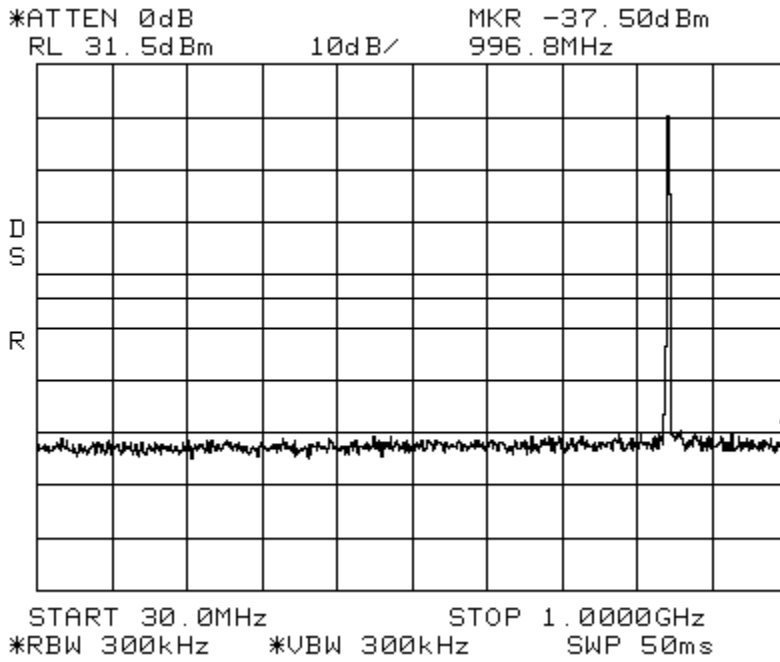

Intermodulation iDEN_Low Spectrum 800 MHz SMR
Span: 1 GHz to 10 GHz RBW/VBW: 1 MHz

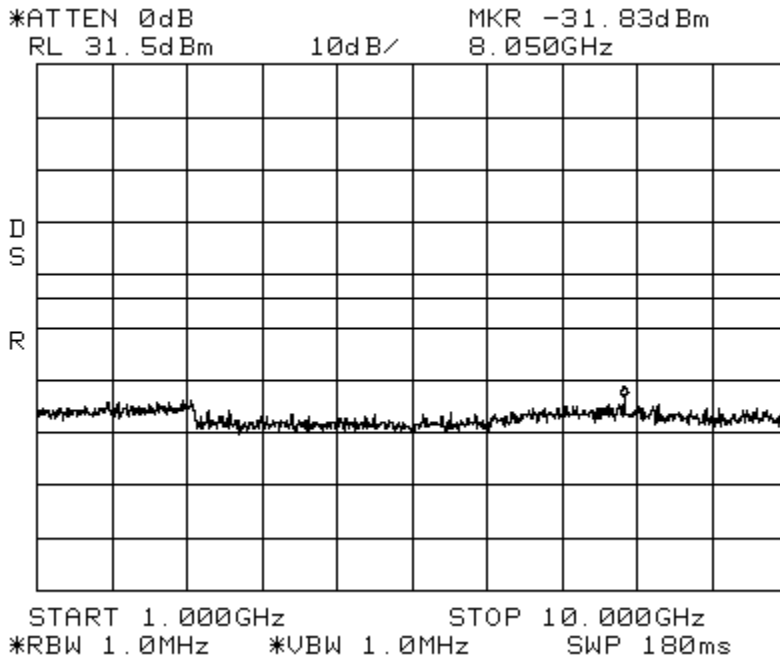

Intermodulation

iDEN_High

Spectrum 800 MHz SMR

Center: 860 MHz

Span: 25 MHz

RBW/VBW: 100 kHz

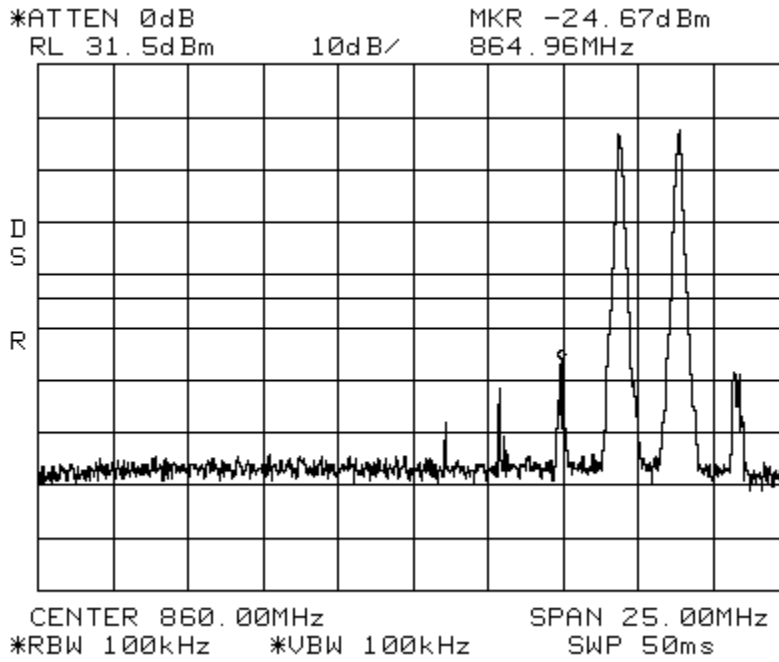

Intermodulation

iDEN_High

Spectrum 800 MHz SMR

Span: 30 MHz to 1 GHz

RBW/VBW: 300 kHz

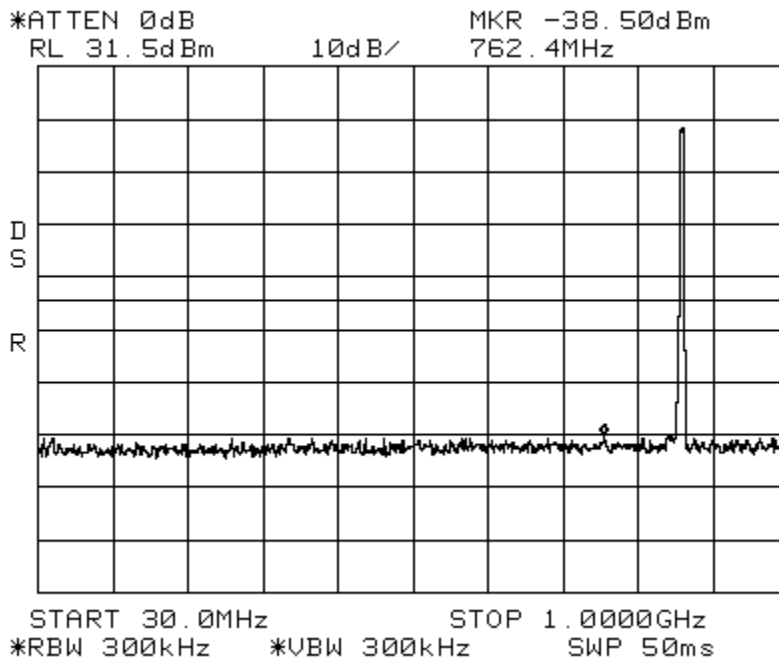

Intermodulation iDEN_High Spectrum 800 MHz SMR

Span: 1 GHz to 10 GHz RBW/VBW: 1 MHz

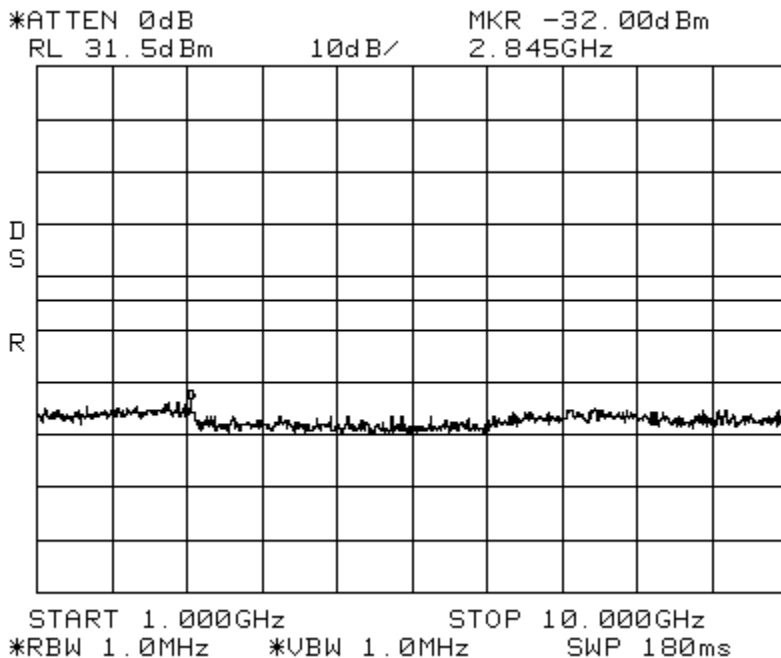

Intermodulation iDEN_Apart Spectrum 800 MHz SMR

Center: 860 MHz Span: 75 MHz RBW/VBW: 100 kHz

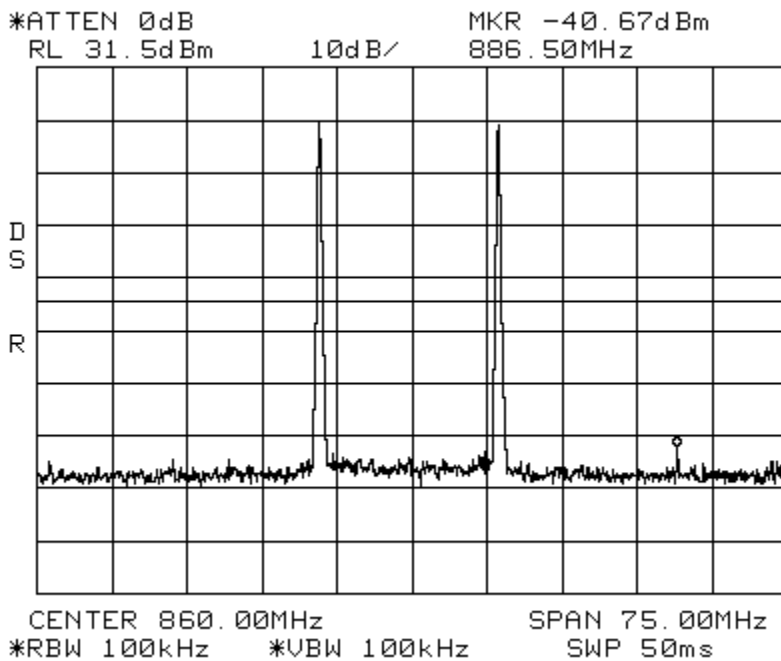

Intermodulation

iDEN_Apart Spectrum 800 MHz SMR

Span: 30 MHz to 1 GHz

RBW/VBW: 300 kHz

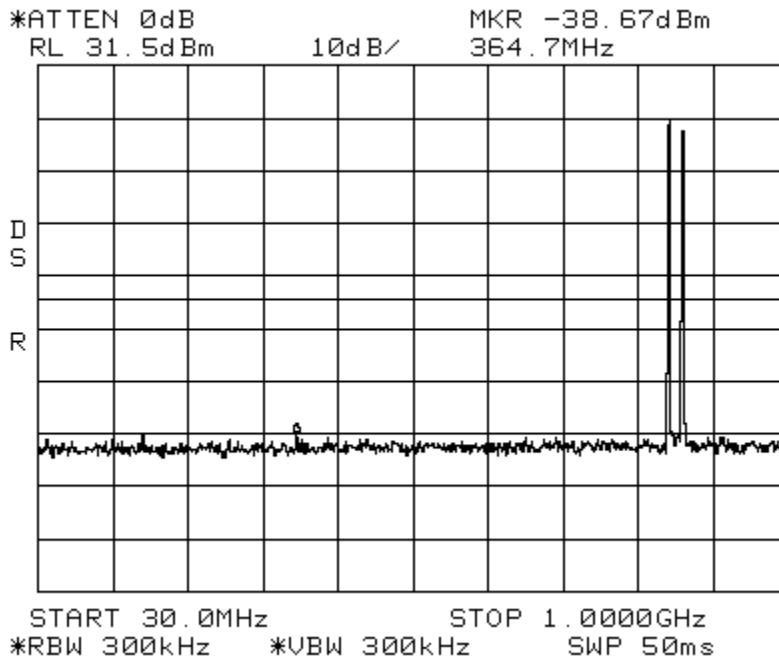

Intermodulation

iDEN_Apart Spectrum 800 MHz SMR

Span: 1 GHz to 10 GHz

RBW/VBW: 1 MHz

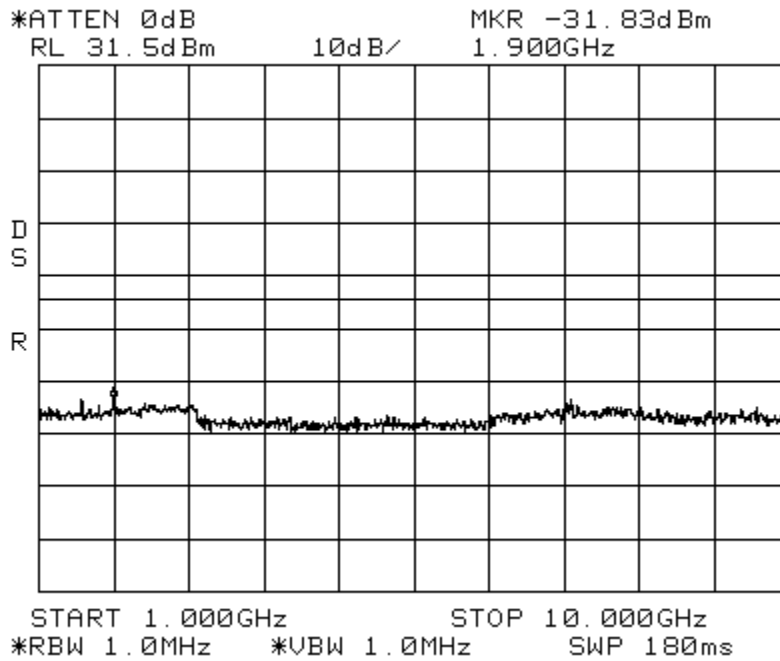

Intermodulation CDMA_Low Spectrum PCS Path 2
 Center: 1960 MHz Span: 90 MHz RBW/VBW: 100 kHz
 ATTEN 10dB MKR -23.50dBm
 RL 41.0dBm 10dB/ 1.93765GHz

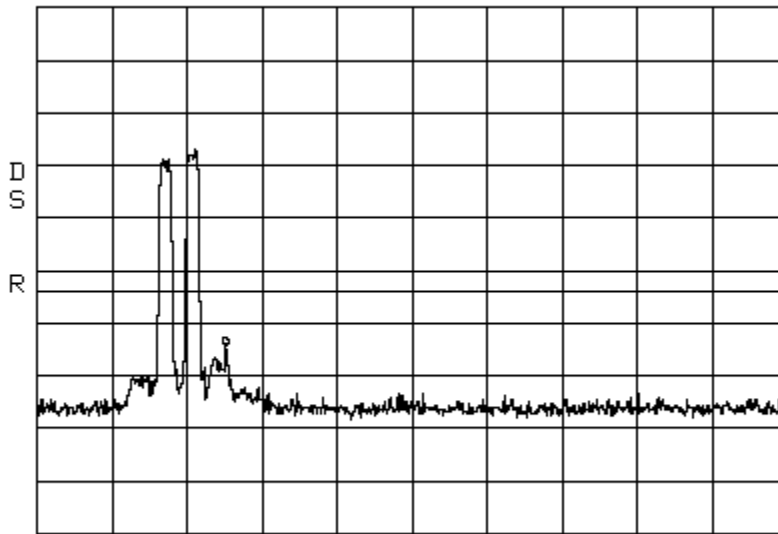

CENTER 1.96000GHz SPAN 90.00MHz
 *RBW 100kHz *VBW 100kHz SWP 50ms

Intermodulation CDMA_Low Spectrum PCS Path 2
 Span: 30 MHz to 1 GHz RBW/VBW: 300 kHz

ATTEN 10dB MKR -29.33dBm
 RL 41.0dBm 10dB/ 311.3MHz

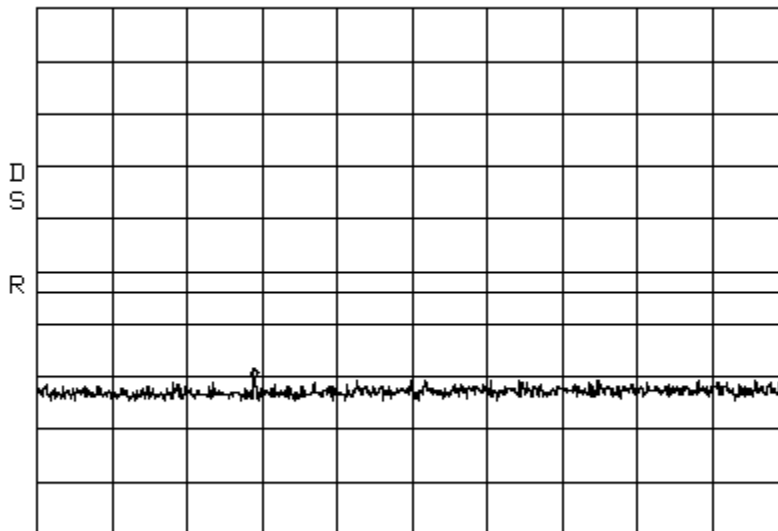

START 30.0MHz STOP 1.0000GHz
 *RBW 300kHz *VBW 300kHz SWP 50ms

Intermodulation
Span: 1 GHz to 20 GHz

CDMA_Low

Spectrum PCS Path 2
RBW/VBW: 1 MHz

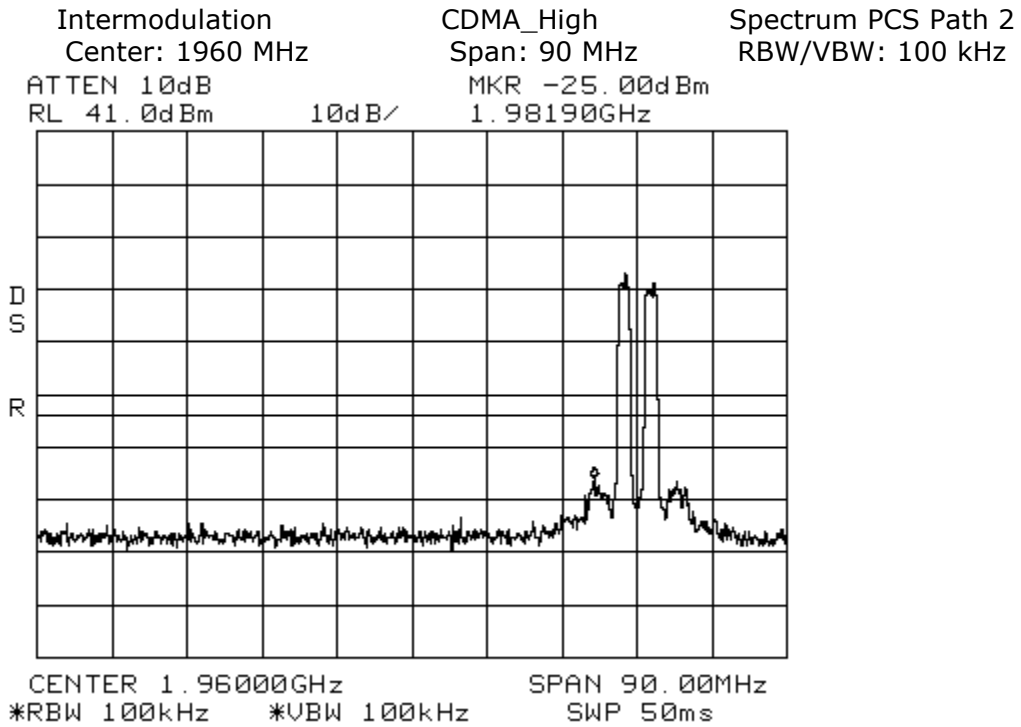
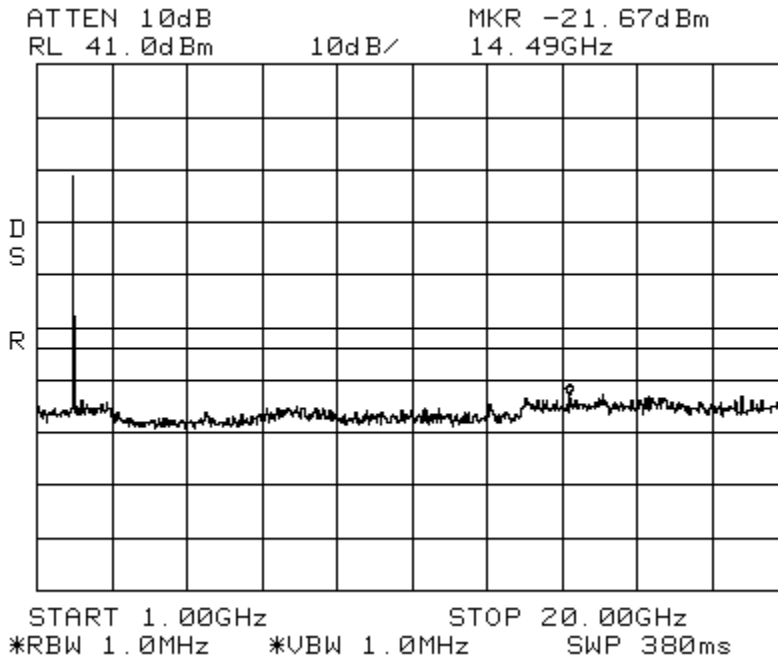

Intermodulation CDMA_High Spectrum PCS Path 2
Span: 30 MHz to 1 GHz RBW/VBW: 300 kHz

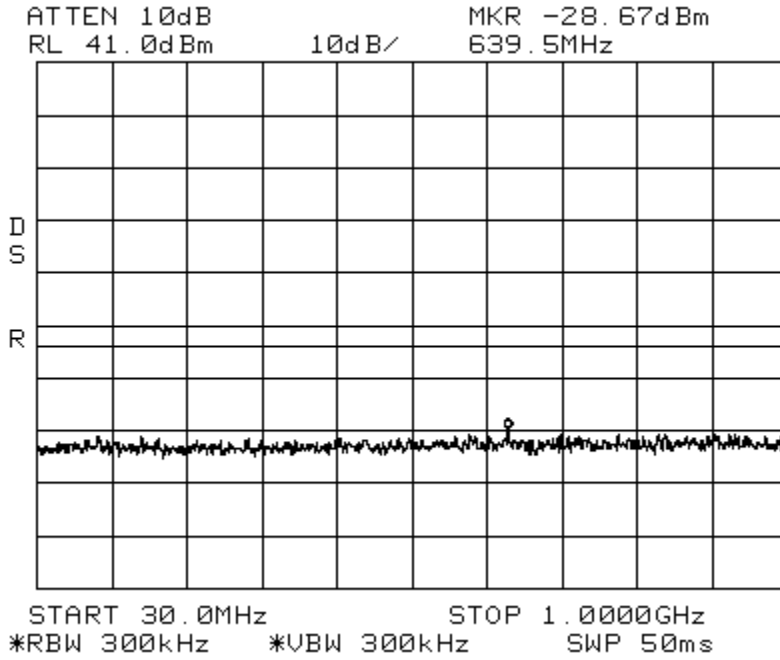

Intermodulation CDMA_High Spectrum PCS Path 2
Span: 1 GHz to 20 GHz RBW/VBW: 1 MHz

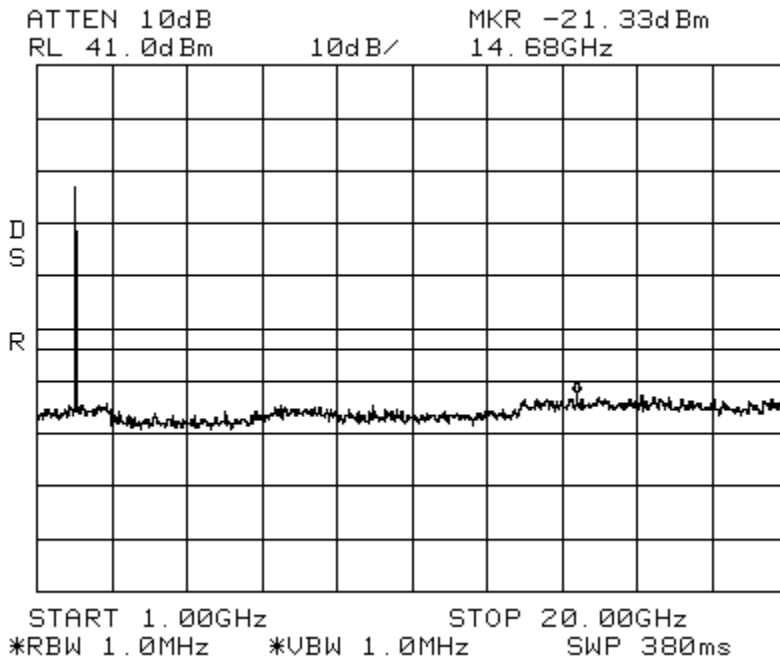

Intermodulation
Center: 1960 MHz
ATTEN 10dB
RL 41.0dBm

CDMA_Apart
Span: 175 MHz
MKR -32.17dBm
2.0169GHz

Spectrum PCS Path 2
RBW/VBW: 100 kHz

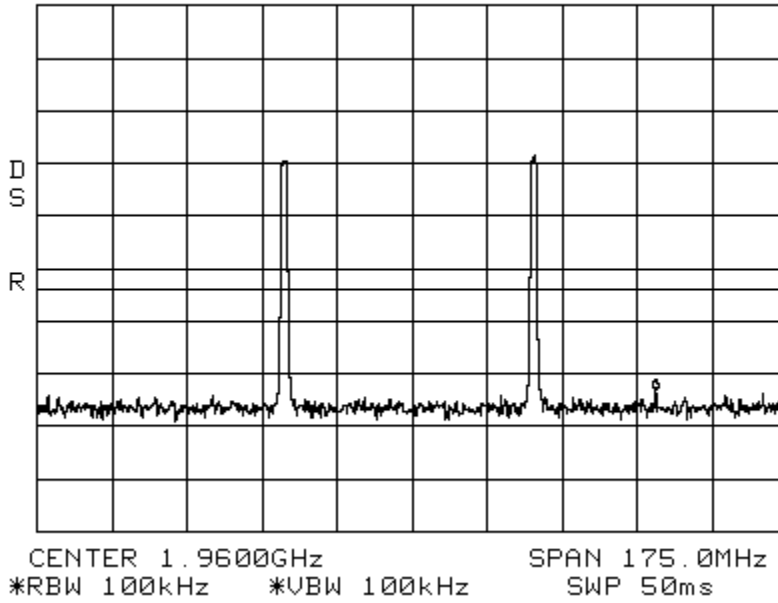

Intermodulation
Span: 30 MHz to 1 GHz

CDMA_Apart

Spectrum PCS Path 2
RBW/VBW: 300 kHz

ATTEN 10dB
RL 41.0dBm

MKR -28.83dBm
796.3MHz

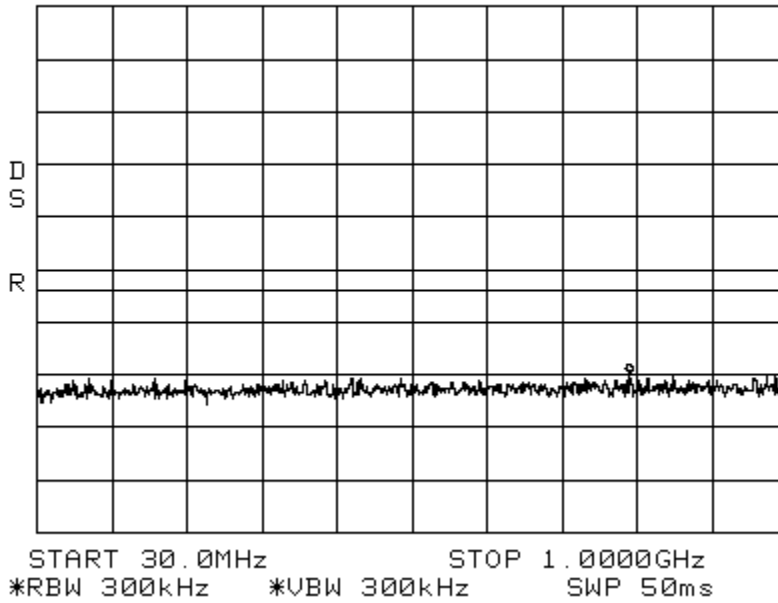

Intermodulation CDMA_Apart Spectrum PCS Path 2
Span: 1 GHz to 20 GHz RBW/VBW: 1 MHz

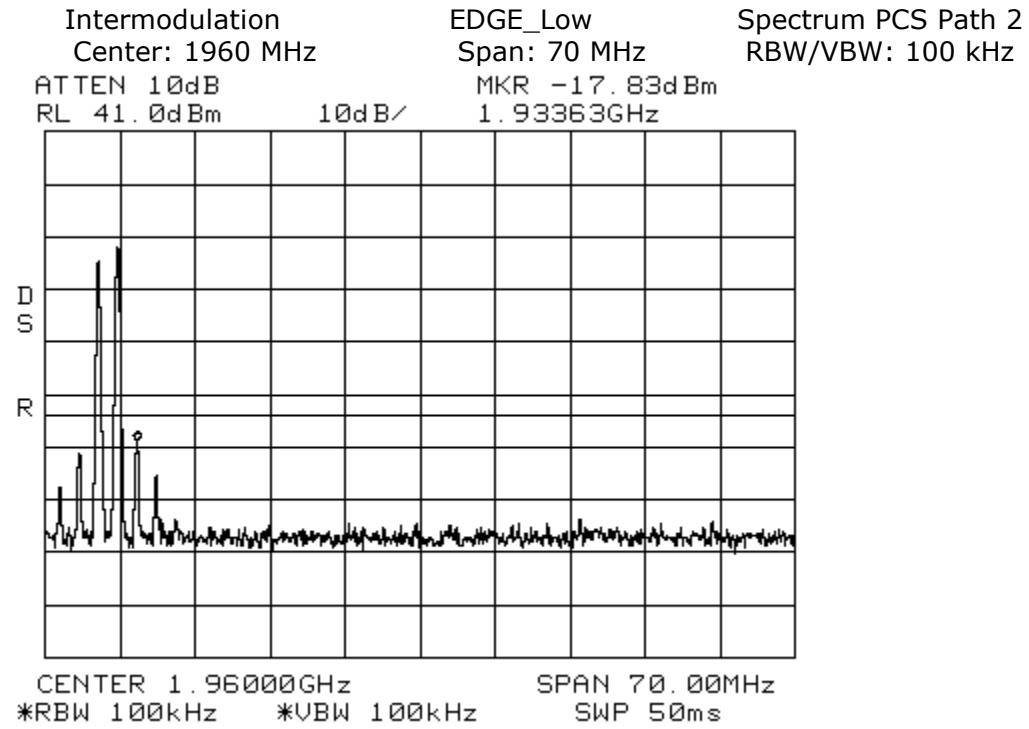
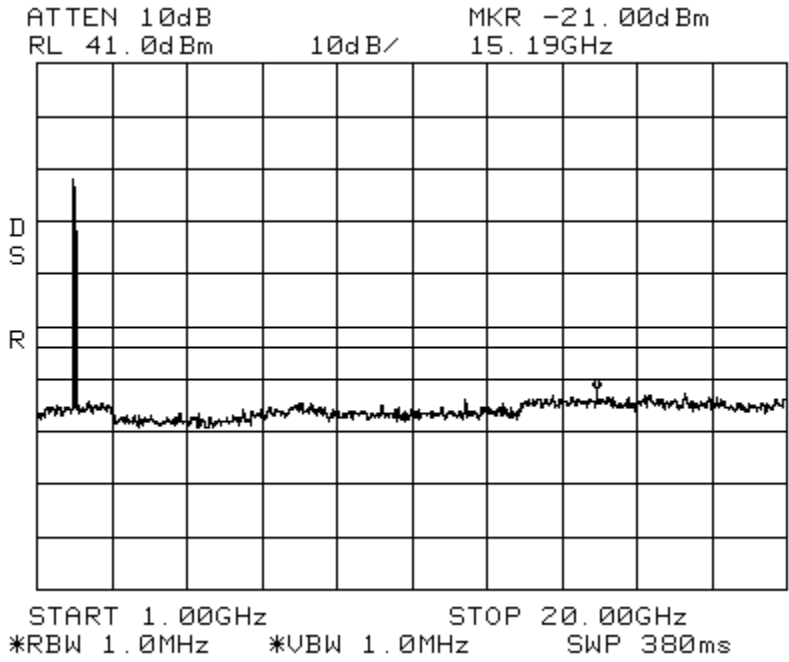

Intermodulation
Start: 1924 MHz

EDGE_Low
Stop: 1929 MHz

Spectrum PCS Path 2
RBW/VBW: 1 MHz



Ref 41 dBm *Att 0 dB *RBW 1 MHz Marker 1 [T1] -17.19 dBm
SWT 2.5 ms 1.927517628 GHz

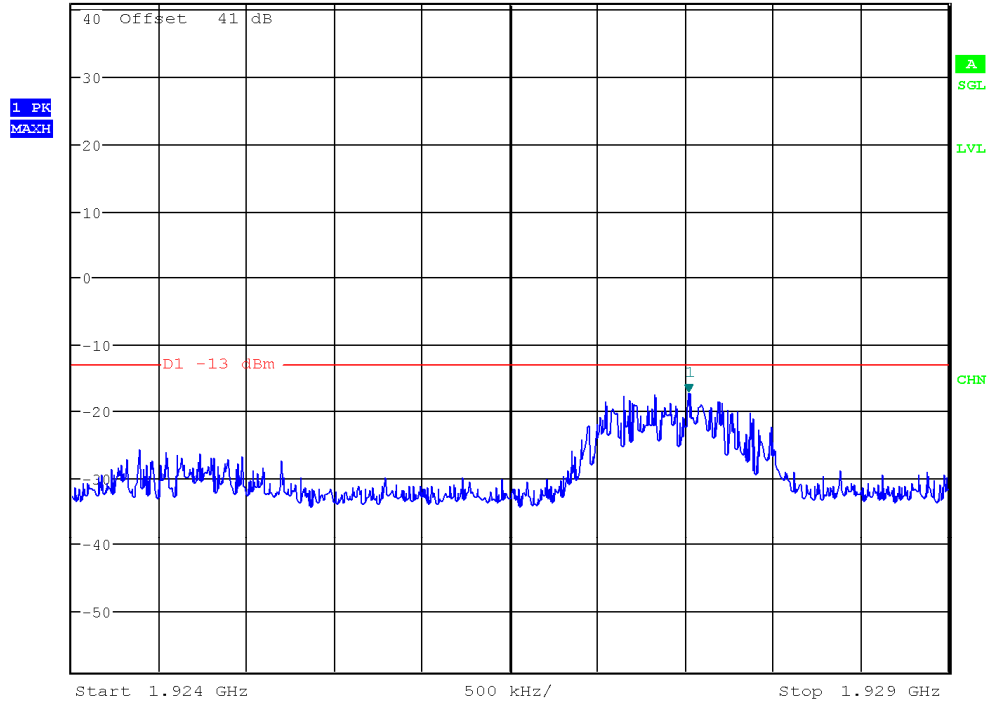

Date: 9.NOV.2011 13:40:00

Intermodulation EDGE_Low Spectrum PCS Path 2
Span: 30 MHz to 1 GHz RBW/VBW: 300 kHz

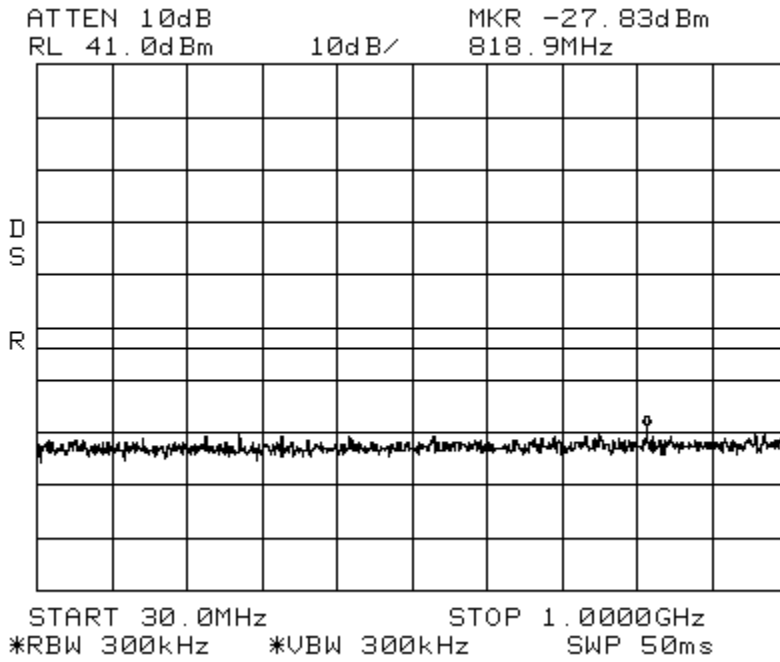

Intermodulation EDGE_Low Spectrum PCS Path 2
Span: 1 GHz to 20 GHz RBW/VBW: 1 MHz

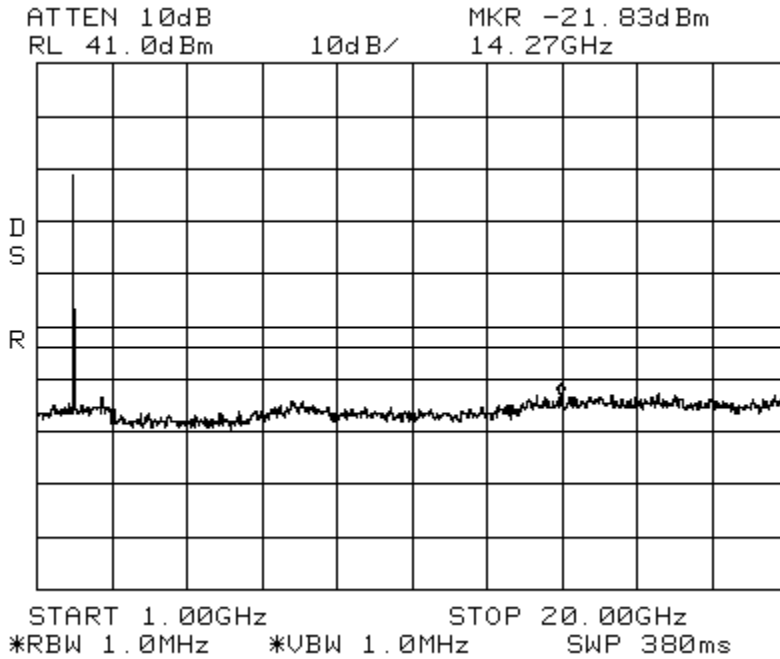

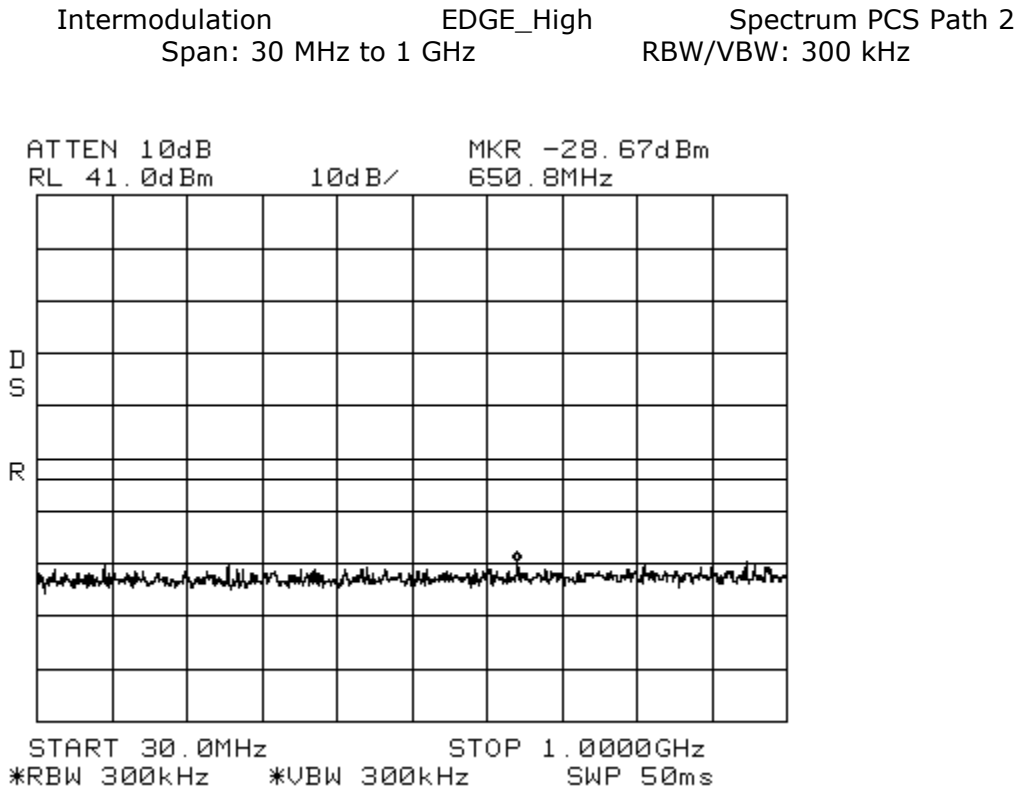
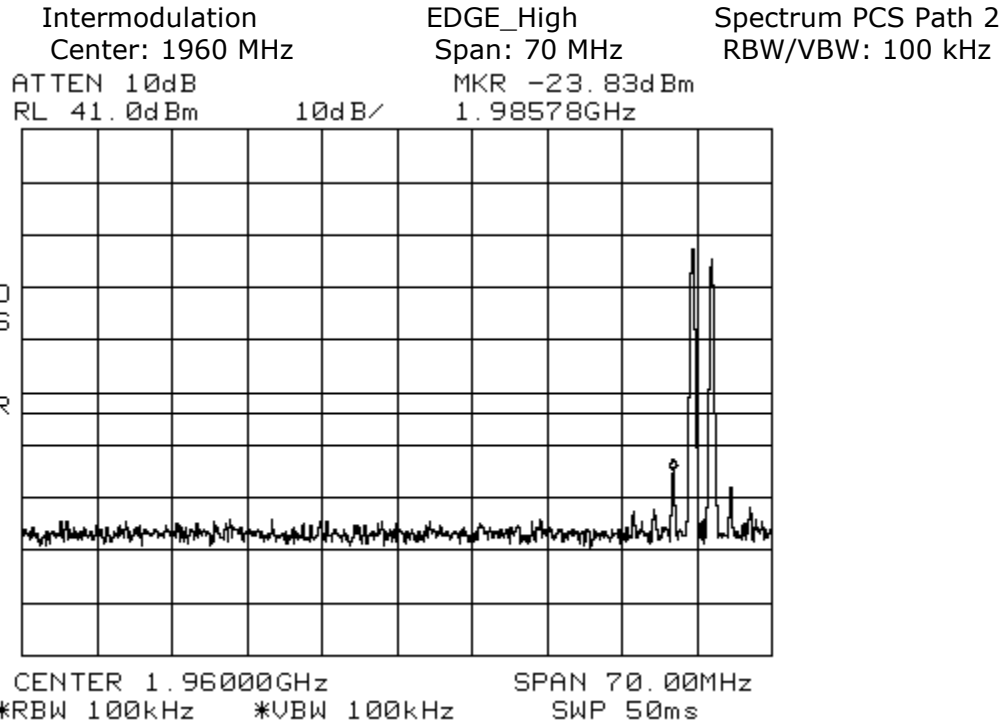

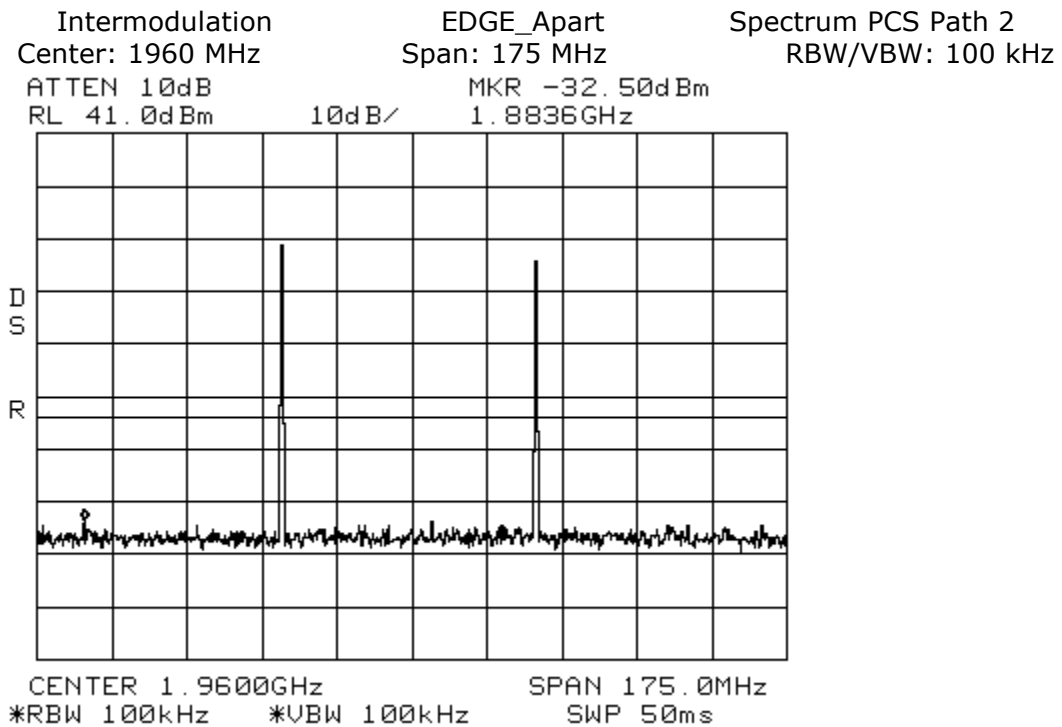
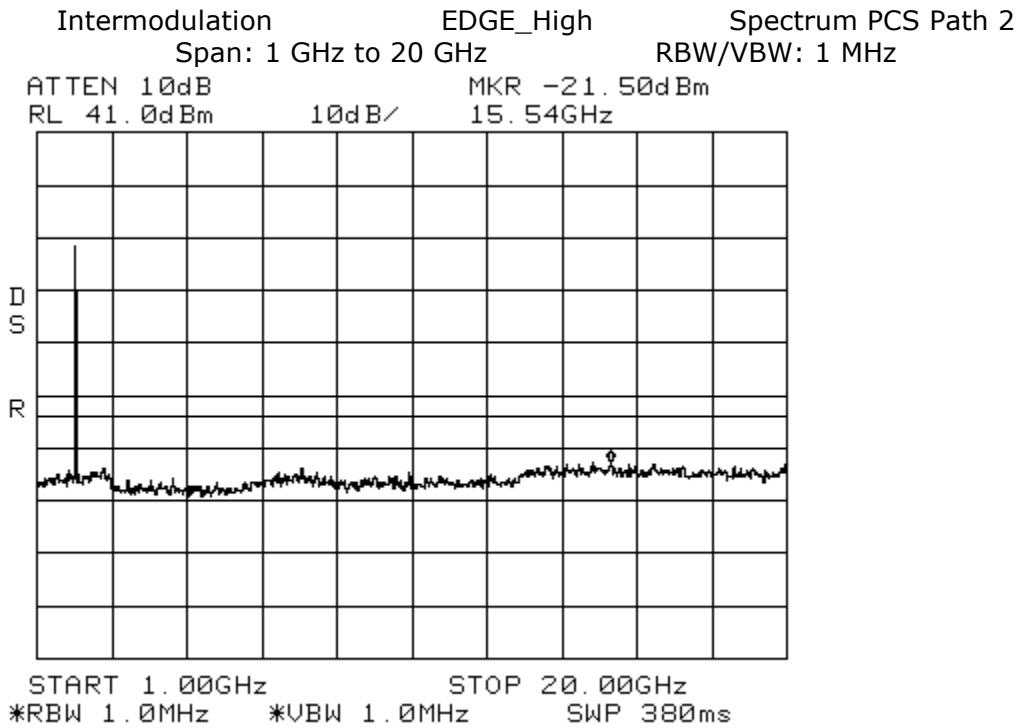

Intermodulation EDGE_Apart Spectrum PCS Path 2
Span: 30 MHz to 1 GHz RBW/VBW: 300 kHz

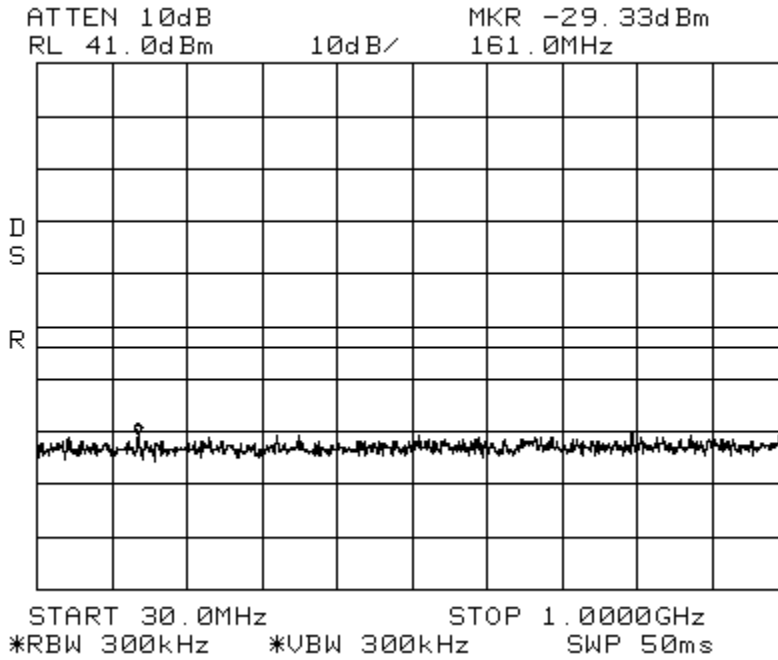

Intermodulation EDGE_Apart Spectrum PCS Path 2
Span: 1 GHz to 20 GHz RBW/VBW: 1 MHz

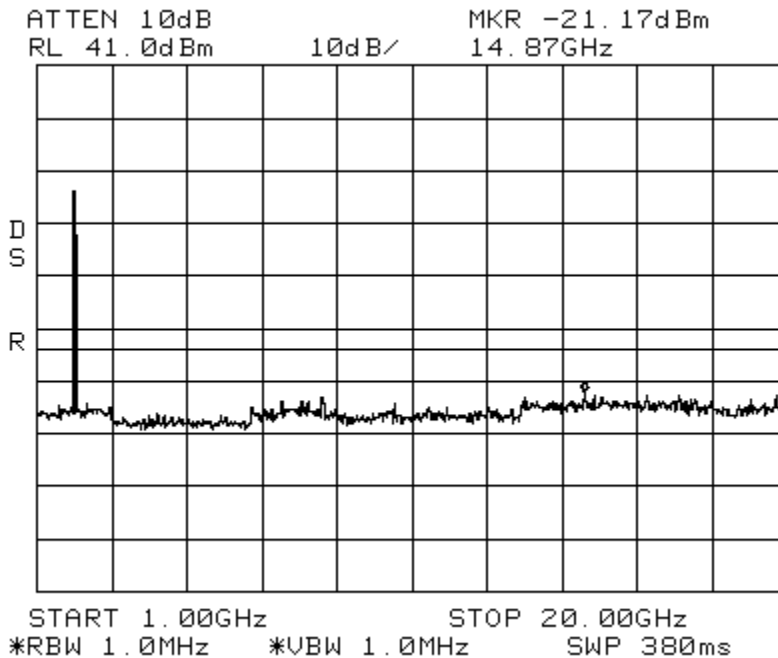

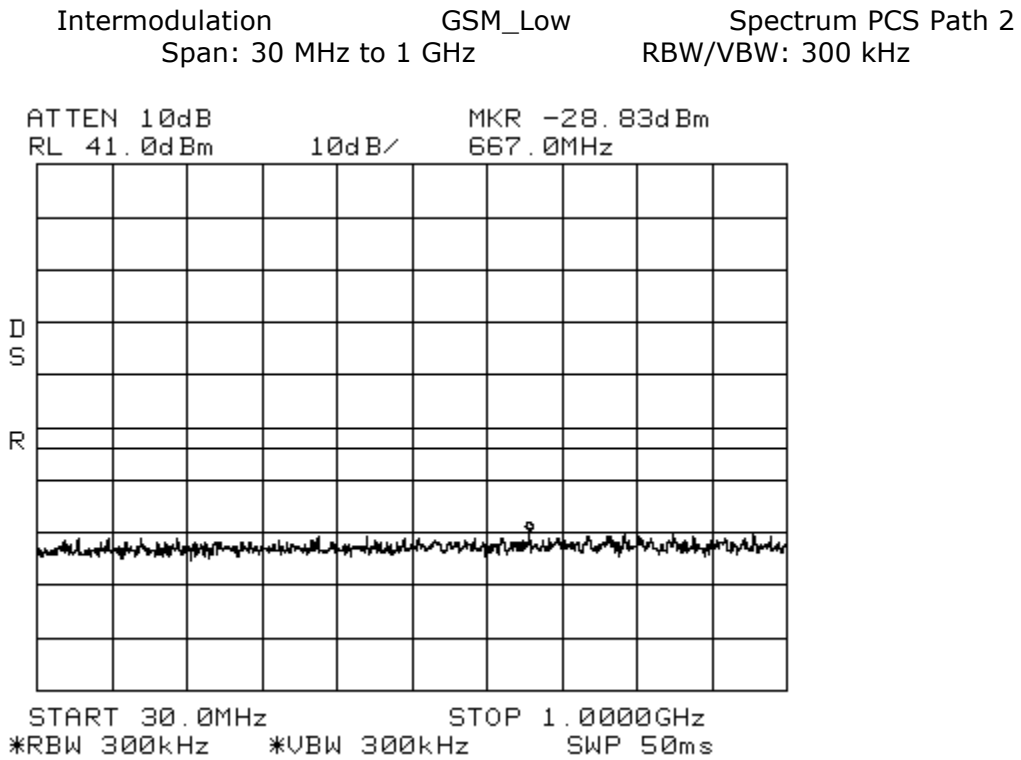
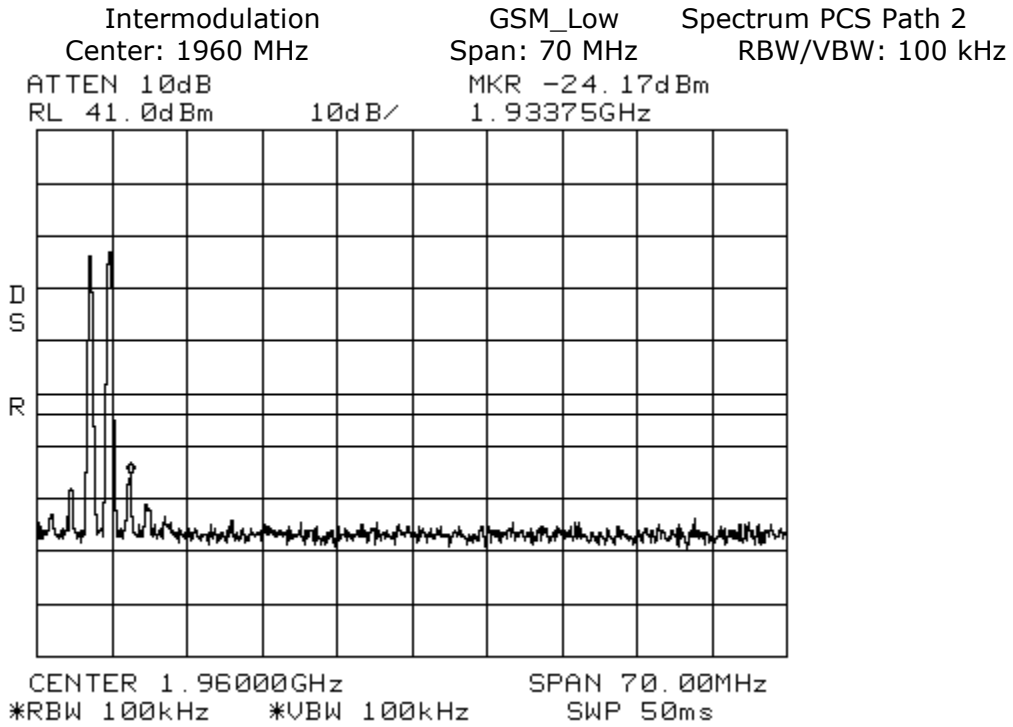

Intermodulation GSM_Low Spectrum PCS Path 2
Span: 1 GHz to 20 GHz RBW/VBW: 1 MHz

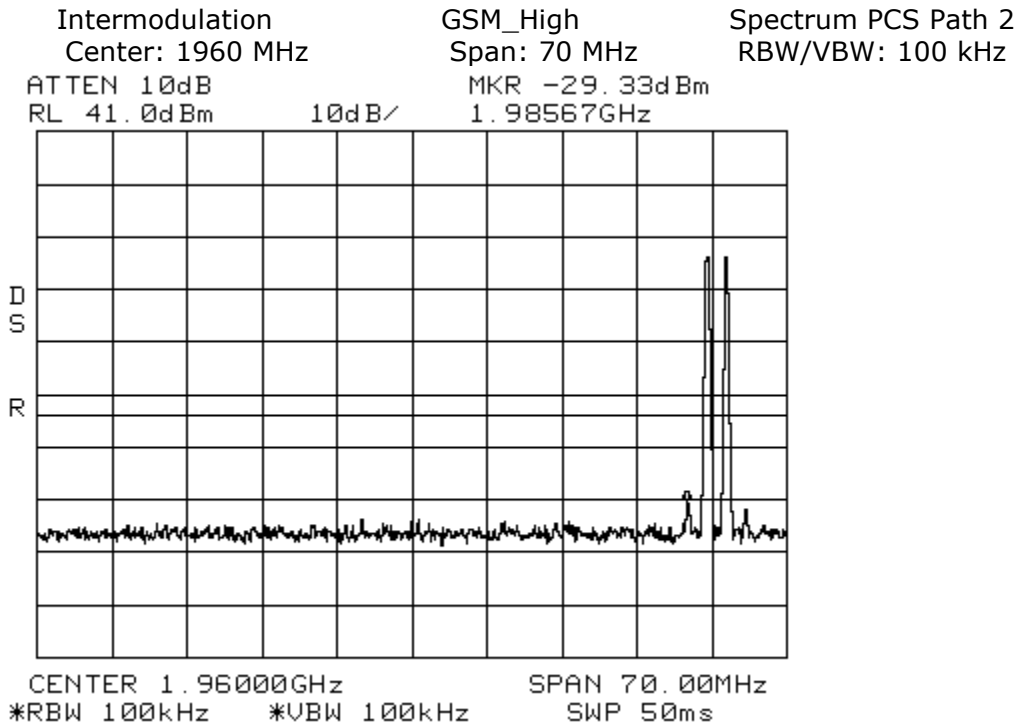
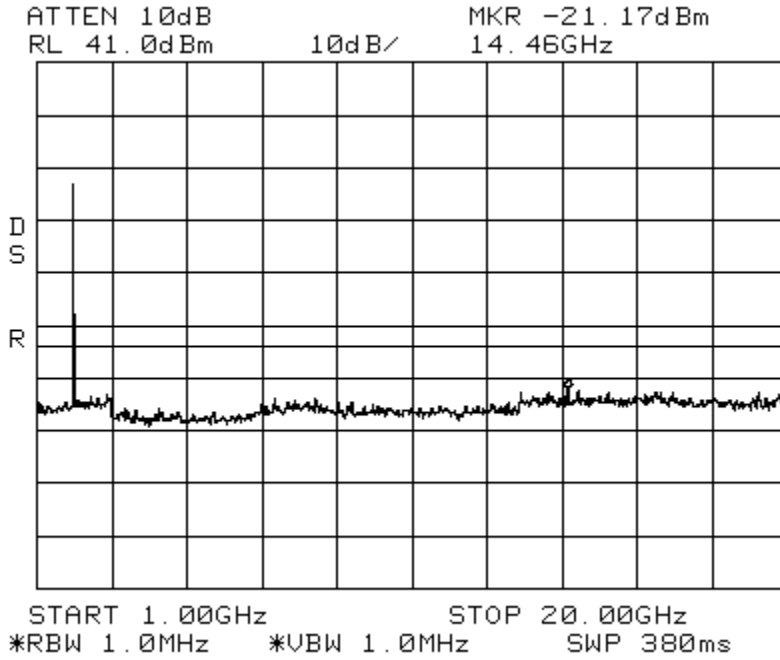

Intermodulation GSM_High Spectrum PCS Path 2
Span: 30 MHz to 1 GHz RBW/VBW: 300 kHz

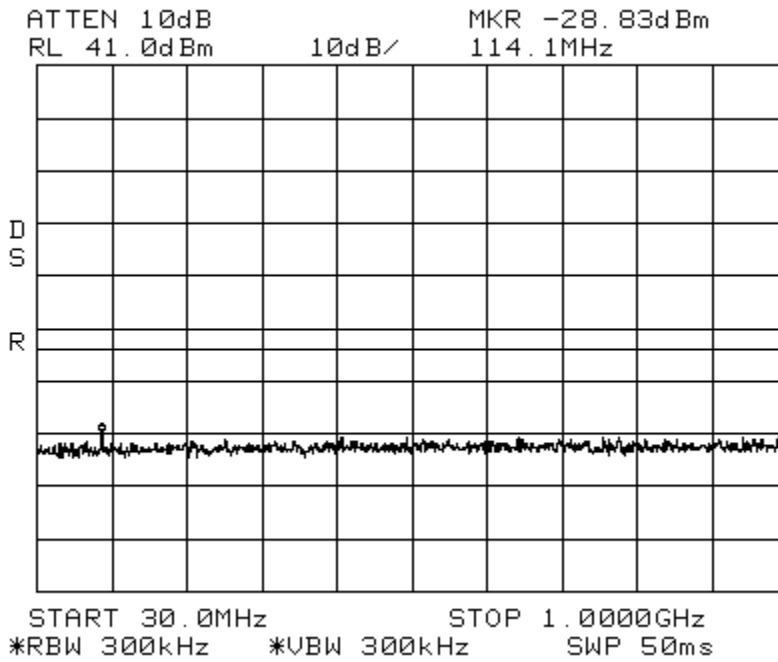

Intermodulation GSM_High Spectrum PCS Path 2
Span: 1 GHz to 20 GHz RBW/VBW: 1 MHz

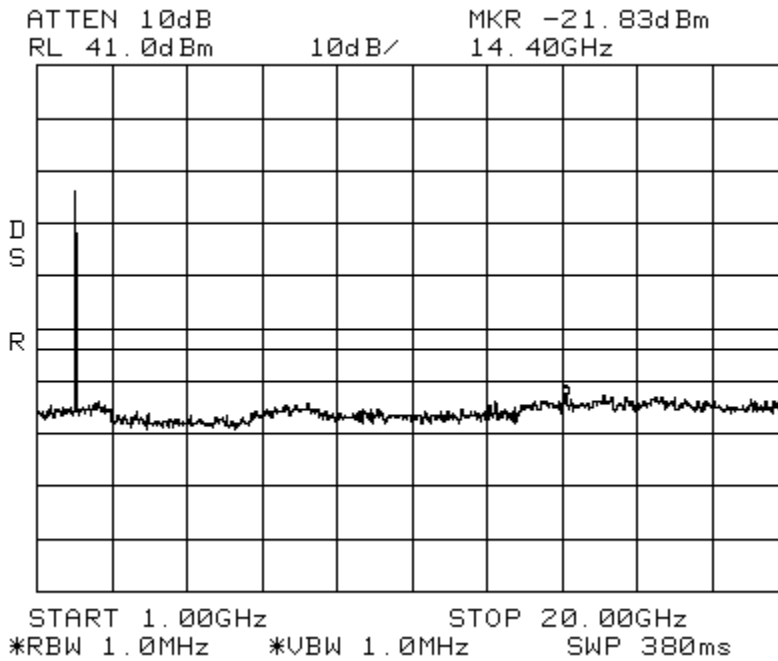

Intermodulation
Center: 1960 MHz

GSM_Apart
Span: 175 MHz

Spectrum PCS Path 2
RBW/VBW: 100 kHz

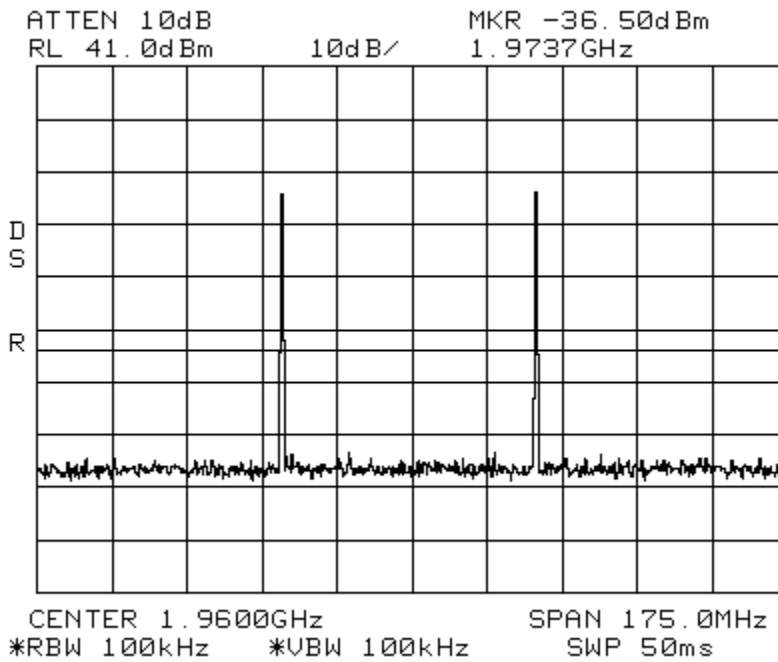

Intermodulation
Span: 30 MHz to 1 GHz

GSM_Apart

Spectrum PCS Path 2
RBW/VBW: 300 kHz

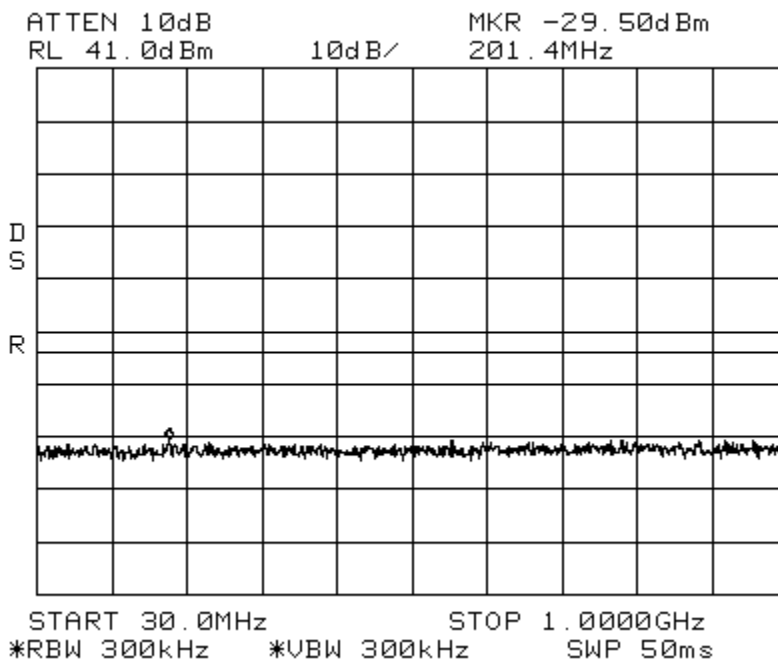

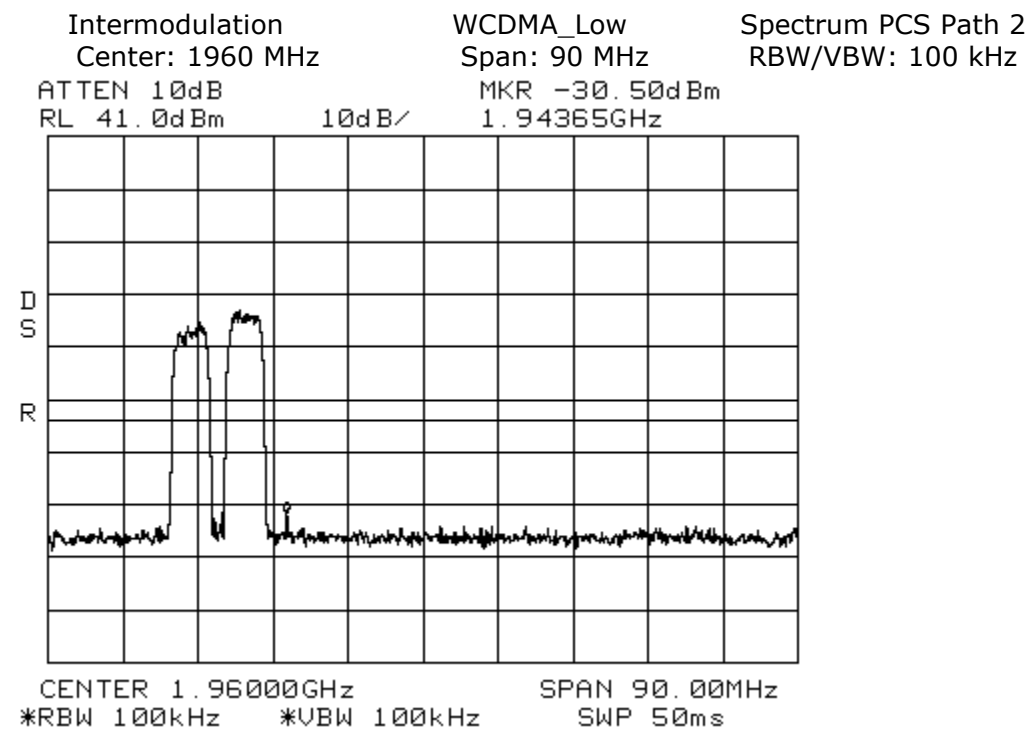
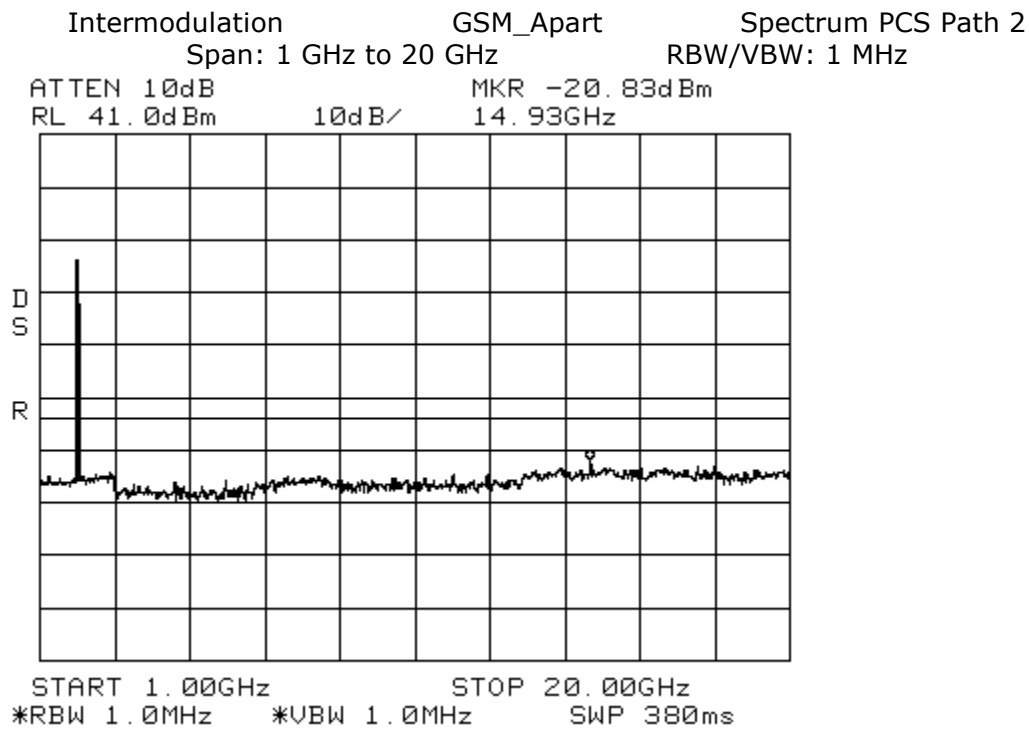

Intermodulation WCDMA_Low Spectrum PCS Path 2
Span: 30 MHz to 1 GHz RBW/VBW: 300 kHz

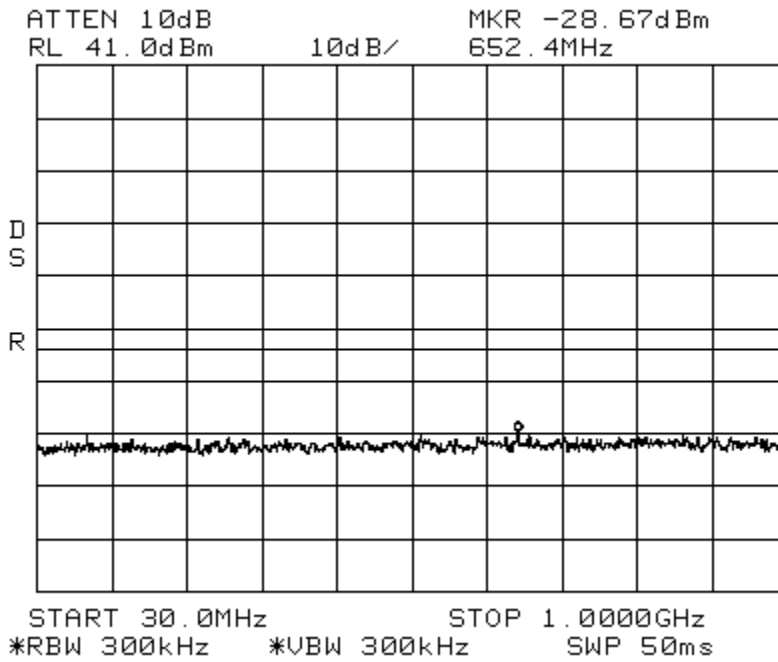

Intermodulation WCDMA_Low Spectrum PCS Path 2
Span: 1 GHz to 20 GHz RBW/VBW: 1 MHz

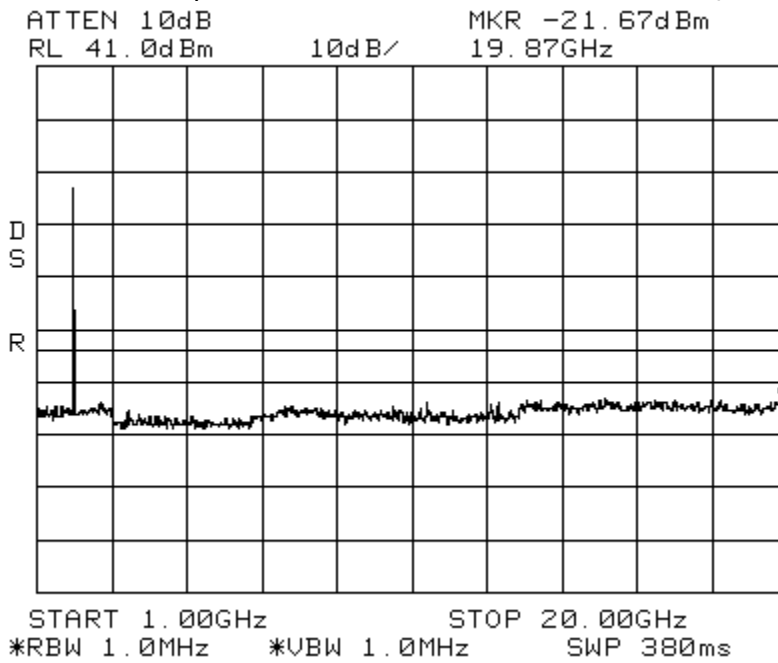

Intermodulation
Center: 1960 MHz

WCDMA_High
Span: 90 MHz

Spectrum PCS Path 2
RBW/VBW: 100 kHz

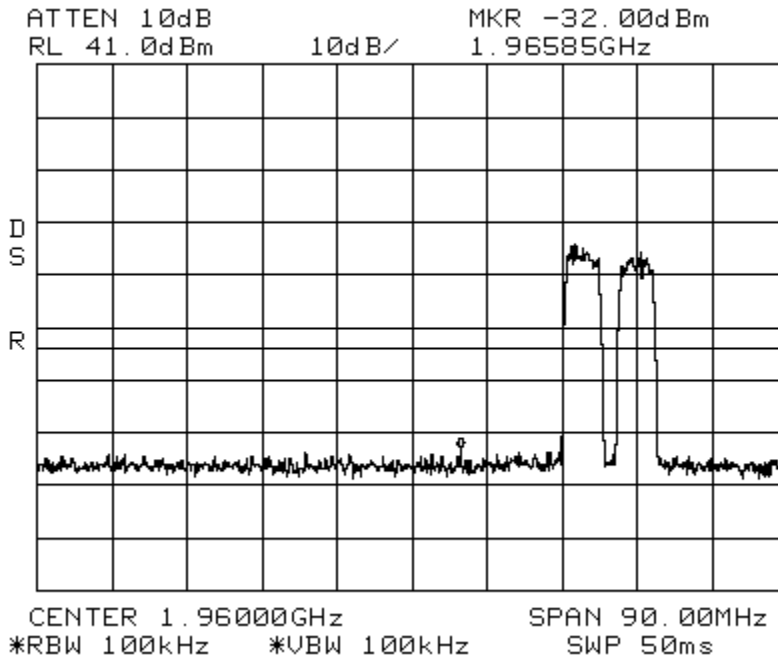

Intermodulation WCDMA_High Spectrum PCS Path 2
Span: 30 MHz to 1 GHz RBW/VBW: 300 kHz

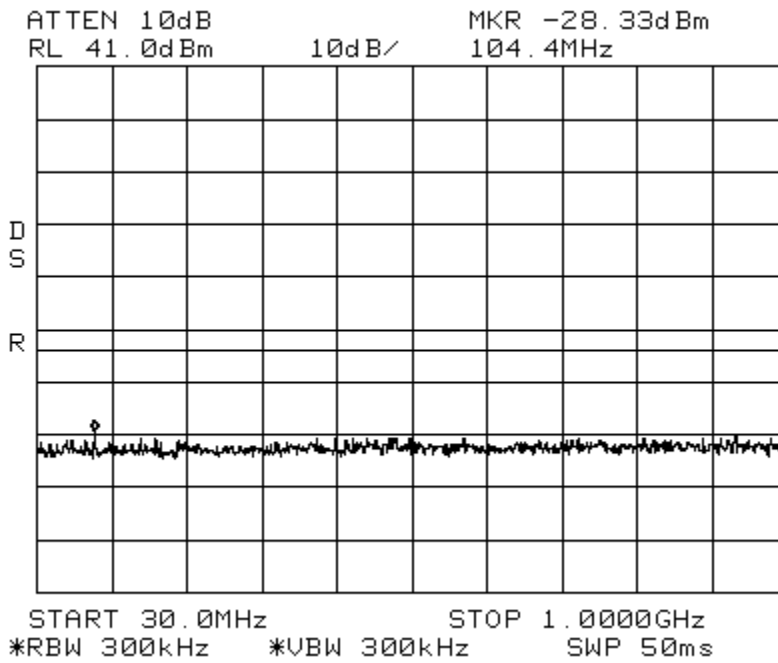

Intermodulation WCDMA_High Spectrum PCS Path 2
Span: 1 GHz to 20 GHz RBW/VBW: 1 MHz

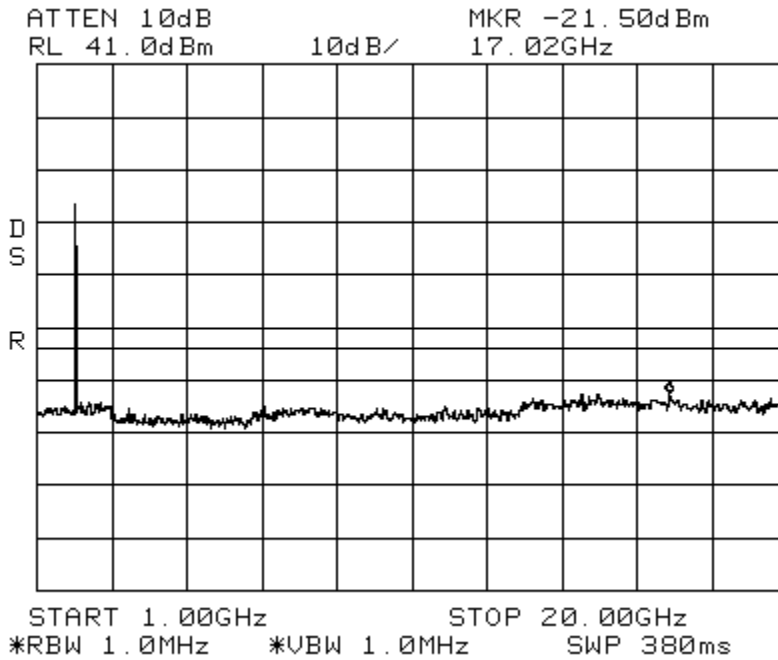

Intermodulation WCDMA_Apart Spectrum PCS Path 2
Center: 1960 MHz Span: 175 MHz RBW/VBW: 100 kHz

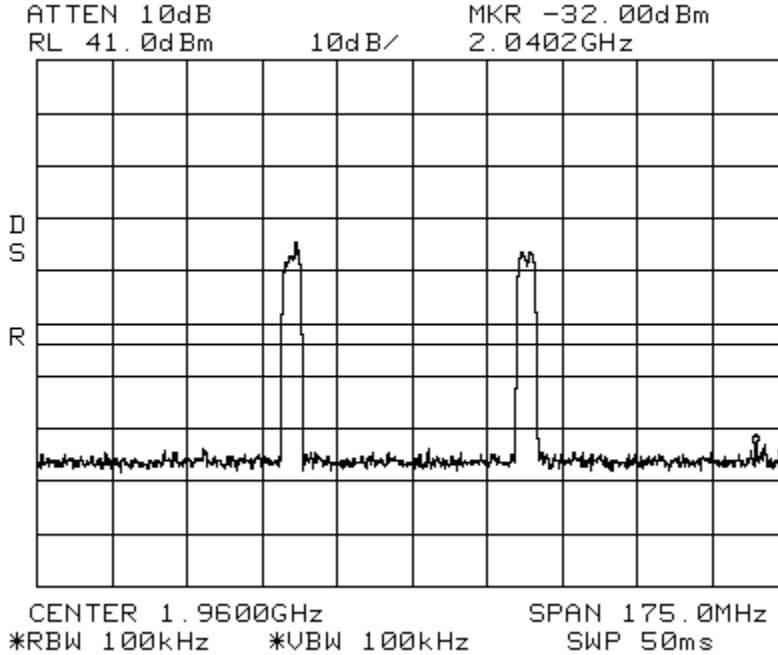

Intermodulation WCDMA_Apart Spectrum PCS Path 2
Span: 30 MHz to 1 GHz RBW/VBW: 300 kHz

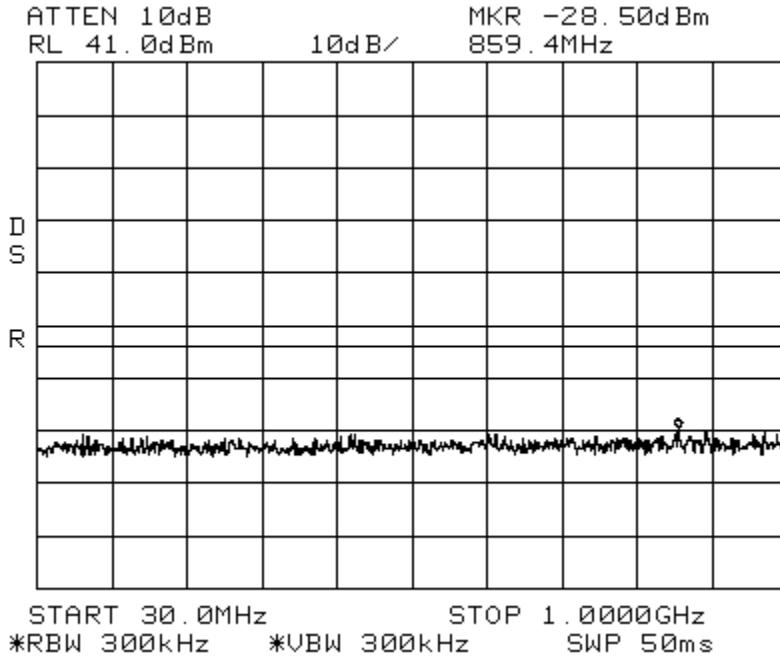

Intermodulation WCDMA_Apart Spectrum PCS Path 2
Span: 1 GHz to 20 GHz RBW/VBW: 1 MHz

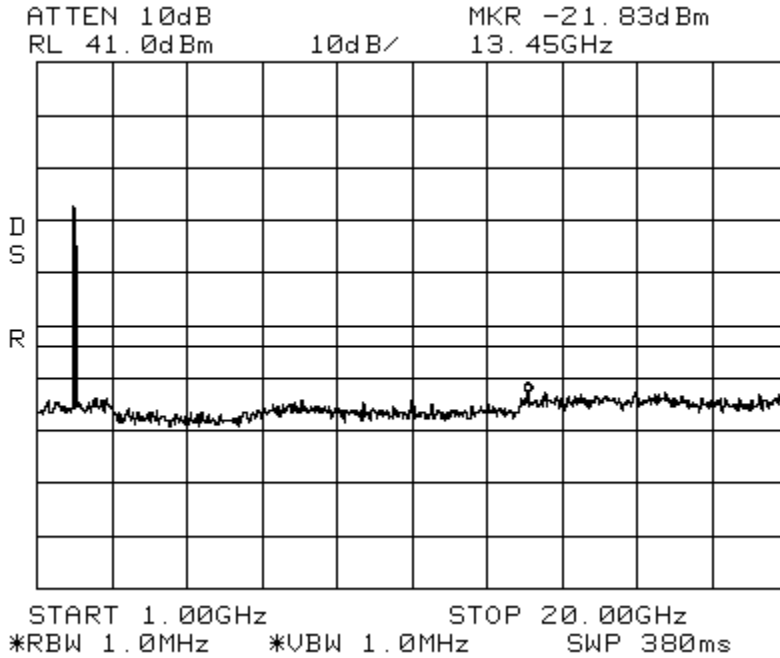

7.5 Occupied Bandwidth Modulation Test

[Table of Contents; Section 1.0](#)

[Back to Emission Limits; Section 5.1.3](#)

An input/output Occupied Bandwidth test was done with modulation types: iDEN, APCO 25 C4FM, CDMA, GSM, EDGE, & WCDMA. The purpose was to determine the amount of distortion added to different types of modulation schemes by the EUT. The following plots show input signals vs. output signals.

The resolution bandwidth is reduced to 1% of the estimated emission bandwidth and the video bandwidth is set to 3 times the resolution bandwidth. The markers are moved to the -20 dB points (from the previously established center frequency level) on either side of center frequency.

Results:

Pass (see plots)

Occupied Bandwidth

APCO 25 C4FM_Signal_In

Spectrum 800 MHz SMR

Span: 25 kHz

RBW: 300 Hz VBW: 1 kHz

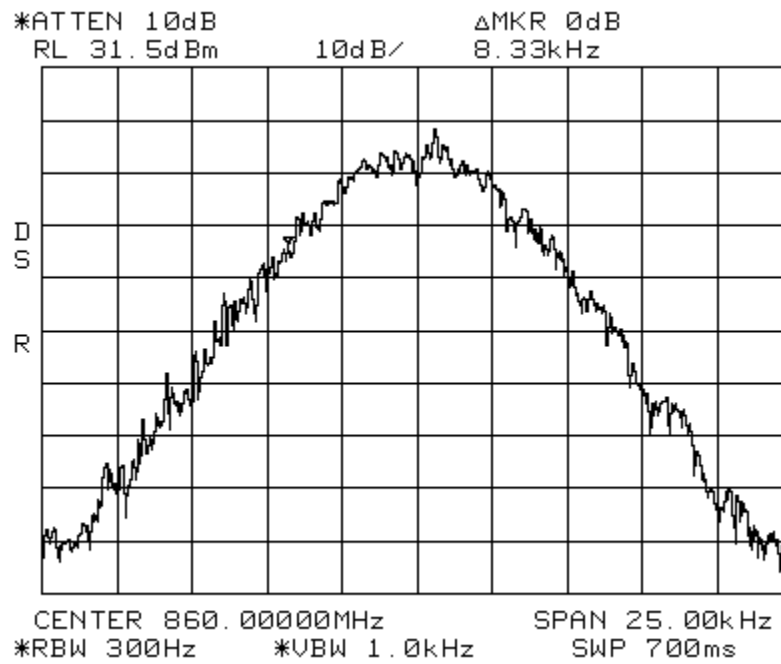

Occupied Bandwidth

APCO 25 C4FM_Signal_Out Spectrum 800 MHz SMR

Span: 25 kHz

RBW: 300 Hz VBW: 1 kHz

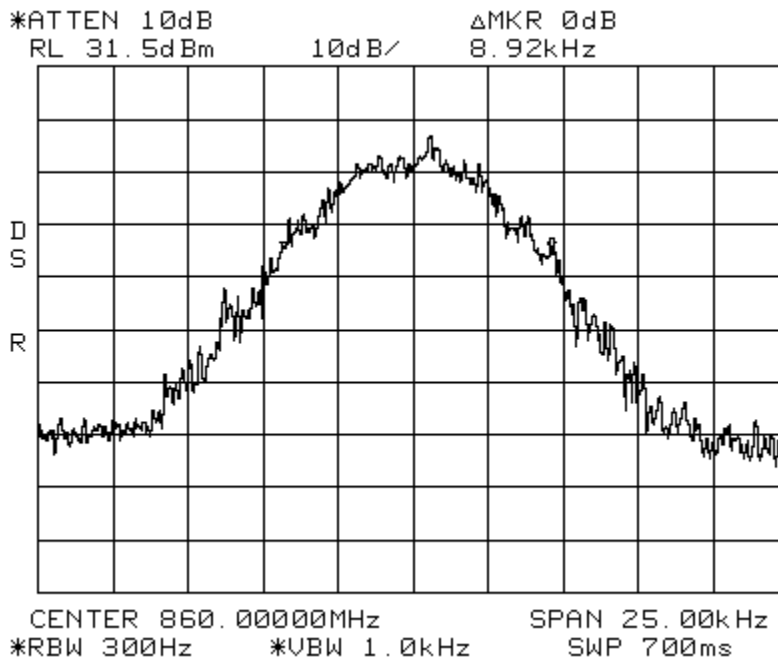

Occupied Bandwidth

iDEN_Signal_In

Spectrum 800 MHz SMR

Span: 25 kHz

RBW: 300 Hz VBW: 1 kHz

*ATTEN 0dB
RL 31.5dBm 10dB/ ΔMKR -.50dB
18.67kHz

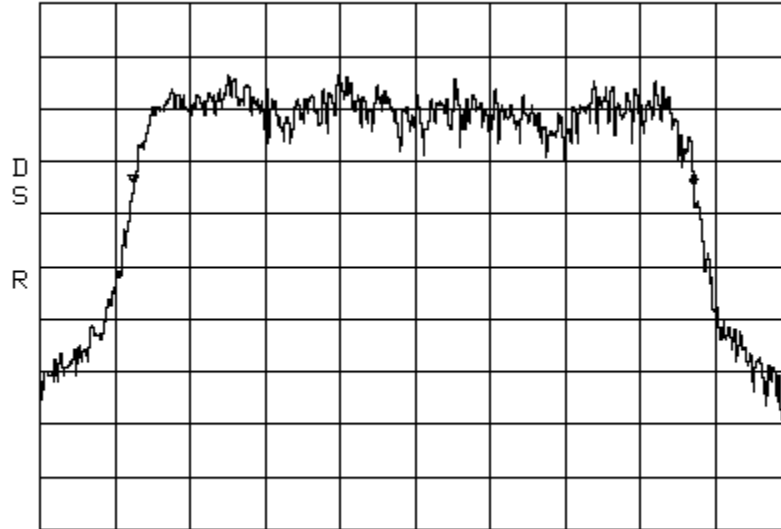

CENTER 860.00000MHz SPAN 25.00kHz
*RBW 300Hz *VBW 1.0kHz SWP 700ms

Occupied Bandwidth

iDEN_Signal_Out

Spectrum 800 MHz SMR

Span: 25 kHz

RBW: 300 Hz VBW: 1 kHz

*ATTEN 0dB
RL 31.5dBm 10dB/ ΔMKR .84dB
18.63kHz

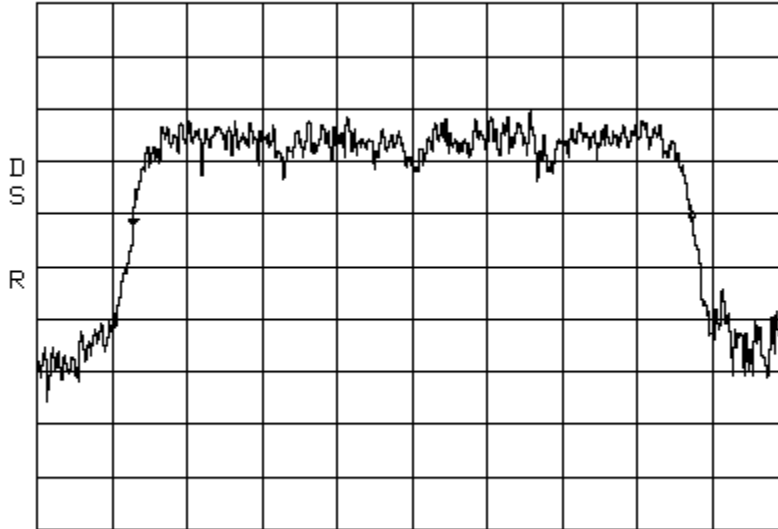

CENTER 860.00000MHz SPAN 25.00kHz
*RBW 300Hz *VBW 1.0kHz SWP 700ms

Occupied Bandwidth CDMA_Signal_In Spectrum PCS Path 2
Span: 1.5 MHz RBW: 30 kHz VBW: 100 kHz
ATTEN 10dB ΔMKR -.67dB
RL 0dBm 10dB/ 1.388MHz

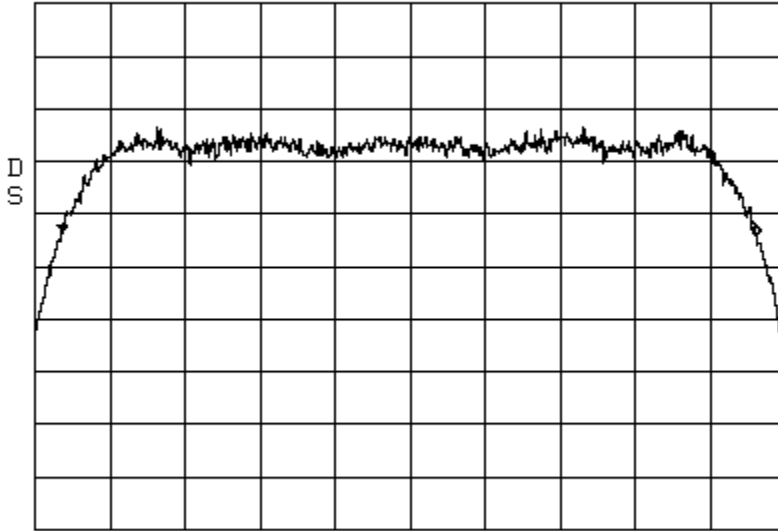

CENTER 1.960000GHz SPAN 1.500MHz
*RBW 30kHz *VBW 100kHz SWP 50ms

Occupied Bandwidth CDMA_Signal_Out Spectrum PCS Path 2
Span: 1.5 MHz RBW: 30 kHz VBW: 100 kHz

ATTEN 10dB ΔMKR -2.00dB
RL 41.0dBm 10dB/ 1.400MHz

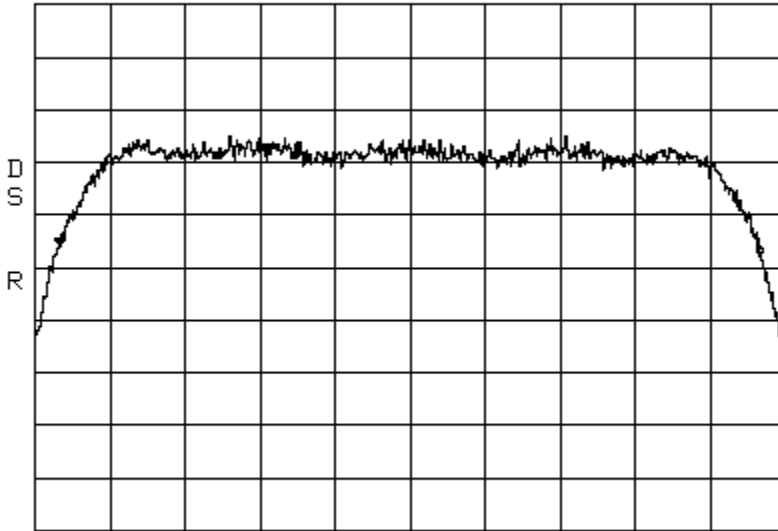

CENTER 1.960000GHz SPAN 1.500MHz
*RBW 30kHz *VBW 100kHz SWP 50ms

Occupied Bandwidth
Span: 350 kHz

EDGE_Signal_In
RBW: 3 kHz

Spectrum PCS Path 2
VBW: 10 kHz

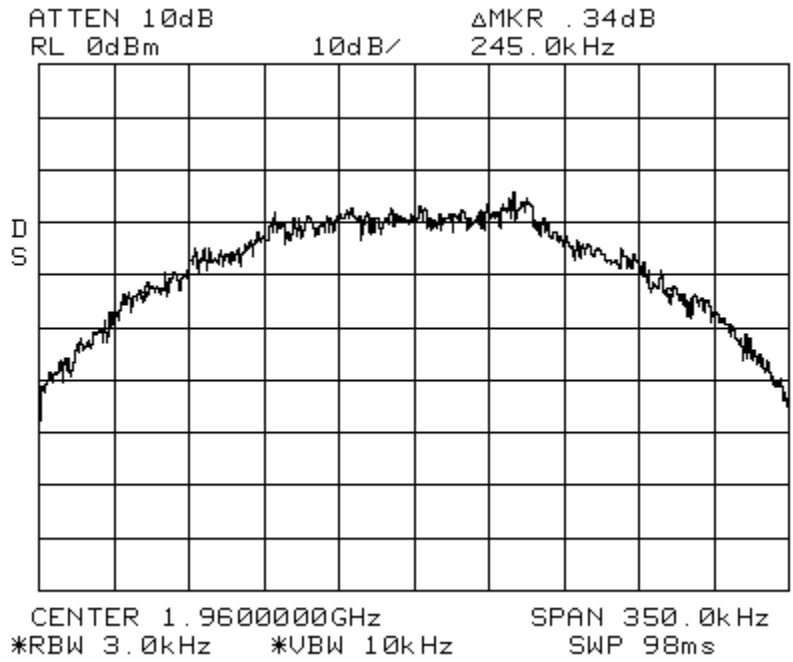

Occupied Bandwidth
Span: 350 kHz

EDGE_Signal_Out
RBW: 3 kHz

Spectrum PCS Path 2
VBW: 10 kHz

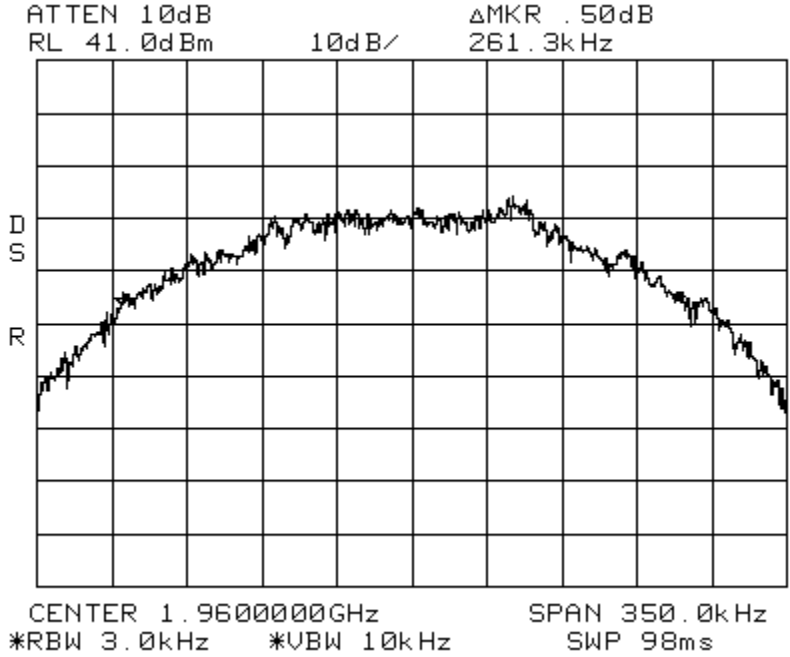

Occupied Bandwidth GSM_Signal_In Spectrum PCS Path 2
 Span: 350 kHz RBW: 3 kHz VBW: 10 kHz
 ATTEN 10dB ΔMKR .17dB
 RL 0dBm 10dB/ 258.4kHz

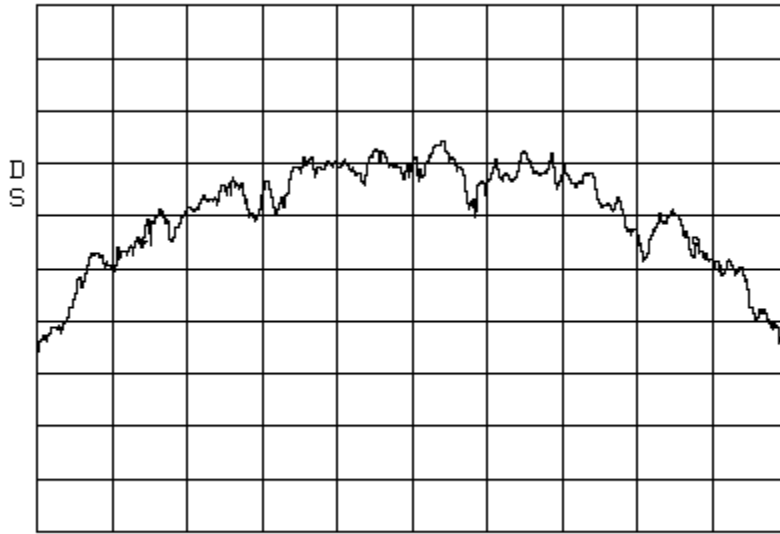

CENTER 1.960000GHz SPAN 350.0kHz
 *RBW 3.0kHz *VBW 10kHz SWP 98ms

Occupied Bandwidth GSM_Signal_Out Spectrum PCS Path 2
 Span: 350 kHz RBW: 3 kHz VBW: 10 kHz

ATTEN 10dB ΔMKR .16dB
 RL 41.0dBm 10dB/ 260.8kHz

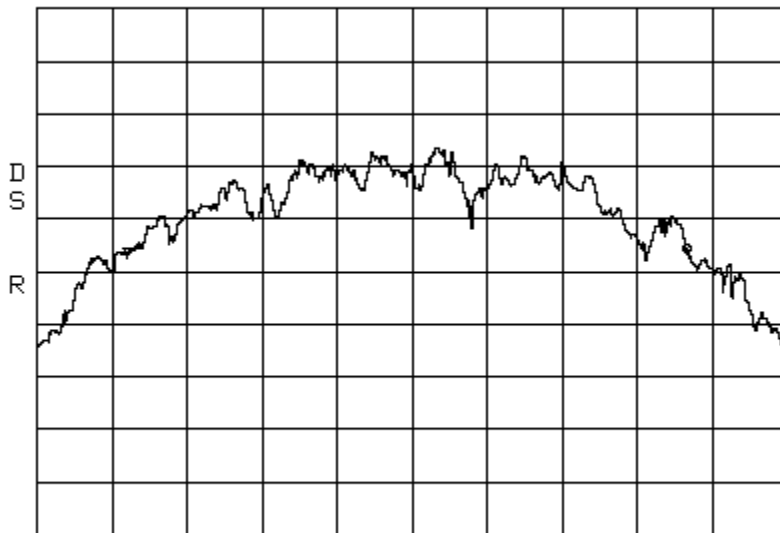

CENTER 1.960000GHz SPAN 350.0kHz
 *RBW 3.0kHz *VBW 10kHz SWP 98ms

Occupied Bandwidth WCDMA_Signal_In Spectrum PCS Path 2
Span: 4.8 MHz RBW: 30 kHz VBW: 100 kHz
ATTEN 10dB ΔMKR -.50dB
RL 0dBm 10dB/ 4.576MHz

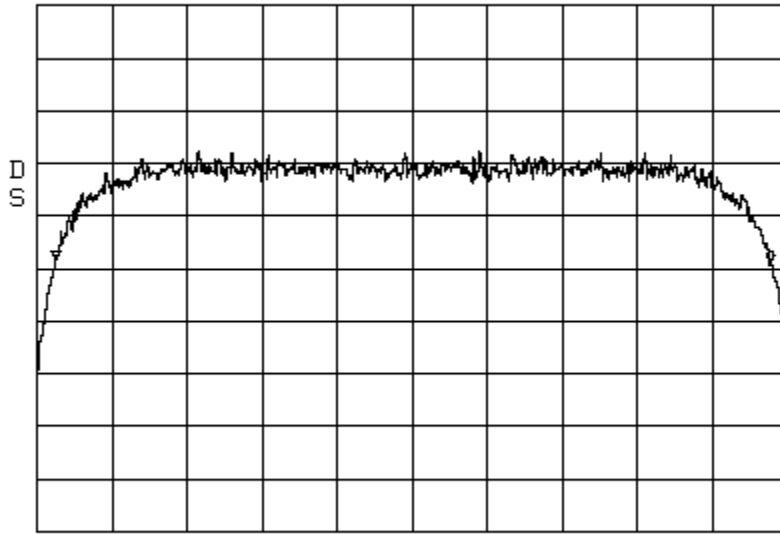

CENTER 1.960000GHz SPAN 4.800MHz
*RBW 30kHz *VBW 100kHz SWP 50ms

Occupied Bandwidth WCDMA_Signal_Out Spectrum PCS Path 2
Span: 4.8 MHz RBW: 30 kHz VBW: 100 kHz

ATTEN 10dB ΔMKR .16dB
RL 41.0dBm 10dB/ 4.592MHz

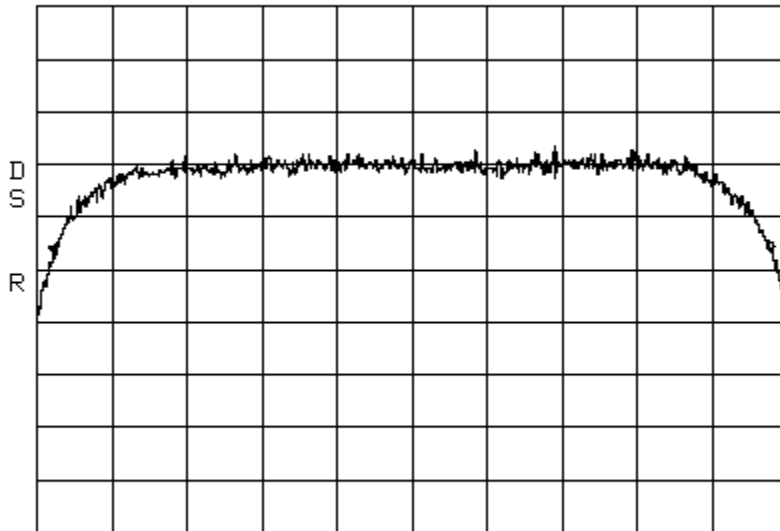

CENTER 1.960000GHz SPAN 4.800MHz
*RBW 100kHz *VBW 100kHz SWP 50ms

8.0

APPENDIX B

Measurement Protocol

[Table of Contents; Section 1.0](#)

[Back to Emission Limits; Section 5.1.3](#)

Measurement Protocol

Environmental conditions of the lab, (ADC)

Temperature: 24° C

Relative Humidity: 21 %

Atmospheric Pressure: 98.8 kPa

Test Methodology:

Emission testing is performed according to the procedures in ANSI C63.4-2003.

Measurement Uncertainty

The test system for conducted emissions is defined as the signal generator(s), the power meter, the spectrum analyzer and the coaxial cable. The equipment comprising the test systems is calibrated prior to testing the EUT.

Justification

The Equipment Under Test (EUT) is configured in a typical user arrangement in accordance with the manufacturer's instructions. A cable is connected to each available port and either terminated with a peripheral into its characteristic impedance or left un-terminated. When appropriate, the cables are manually manipulated with respect to each other to obtain maximum emissions from the unit.

Radiated Emissions

The final level, in dBuV/m, equals the reading from the spectrum analyzer (Level dBuV), adding the antenna correction factor and cable loss factor (Factor dB) to it, and subtracting the preamp gain (and duty cycle correction factor, if applicable). This result then has the limit subtracted from it to provide the Delta, which gives the tabular data as shown in the data sheets in Appendix B.

Example:

FREQ (MHz)	LEVEL (dBuV)	CABLE/ANT/PREAMP (dB) (dB/m) (dB)	FINAL (dBuV/m)	POL/HGT/AZ (m) (deg)	DELTA1
60.80	42.5Qp +	1.2 + 10.9 - 25.5 =	29.1	V 1.0 0.0	-10.9

Substitution Method

A cabinet (or enclosure) radiated emission scan was also made, at Intertek, with the EUT's antenna replaced with a termination to demonstrate case radiation compliance to the -13 dBm requirement. Radiated emissions from the EUT are measured in the frequency range of 30 to 20,000 MHz using a spectrum analyzer and appropriate broadband linearly polarized antennas. Table top equipment is placed on a 1.0 X 1.5 meter non-conducting table 80 centimeters above the ground plane. Floor standing equipment is placed directly on the turntable/ground plane. Interface cables that are closer than 40 centimeters to the ground plane are bundled in the center in a serpentine fashion so they are at least 40 centimeters from the ground plane. Cables to simulators/testers (if used in this test) are routed through the center of the table and to a screen room located outside the test area. The antenna is positioned 3 meters horizontally from the EUT. To locate maximum emissions from the test sample the antenna is varied in height from 1 to 4 meters, measurement scans are made with both horizontal and vertical antenna polarizations and the EUT are rotated 360 degrees. The field strength levels were measured per ANSI C63.4. The EUT is then replaced with a tuned dipole antenna (below 1GHz) or horn antenna (above 1 GHz). The substitute antenna was placed in the same polarization as the test antenna. A signal generator was used to generate a signal level that matched the highest level measured from the EUT. The signal generator level minus the cable loss from the signal generator to the substitute antenna plus the substitute antenna gain equals the spurious power level.

Test Equipment

All measurement instrumentation is traceable to the National Institute of Standards and Technology and is calibrated according to internal procedure.

Radiated Emissions Test Data

[Table of Contents; Section 1.0](#)

Document Name: **100616112MIN-001**

Test Engineer: Richard Blonigen

Date: January 23, 2012

Test Procedure:

Test measurements were made in accordance with ANSI C63.4-2003, Standard Methods of Measurement of Radio Noise Emissions from Low-Voltage Electrical and Electronics Equipment in the Range of 9 kHz to 40 GHz.

Test Site Location:

The test site is a 3 meter Semi-Anechoic Chamber, constructed by Panashield™ Inc. and located inside the building at 7250 Hudson Blvd. Suite 100, Oakdale, MN 55128.

Test Site Description:

The 3 meter Semi-Anechoic Chamber is constructed of Panabolt™ modular RF shielding and self-supported with structural steel designed for the local seismic zone rating. The chamber has the nominal size of 20' wide x 29' long x 18' high. All walls and ceiling of the chamber are treated with FFG-1000 Ferrite Grid absorber which was developed specifically to meet international requirements for EMC anechoic chambers for emissions and immunity measurements. To meet high frequency testing white HY-35 hybrid absorber is mounted on the ferrites in specular regions of the chamber.

The chamber has a 2 meter diameter ANSI test volume area and meets the requirements of ANSI C63.4 (1992), EN55022, and FCC Part 15 standards for testing at a 3 meter path length.

FCC Registration Number: 0007355381

IC Registration Number: 4359A