



Test Report Summary

FCC CFR 47, Part 27

Wireless Communications Service

Manufacturer: ADC Telecommunications, Inc.

Name of Equipment: Spectrum 700 Path 1/AWS Path1 SRAU

Model Number(s): SPT-S2-70AWS-1-SISO

Manufacturer's Address: 1187 Park Place
Shakopee, MN 55739

Test Report Number: MN120731 700P1 AWSP1 SRAU

Test Date(s): 16 - 20 June, 2012 (Intertek)
25, 27, 28 June, 2012 (ADC)
11, 12 & 13 July, 2012 (ADC)

According to testing performed at Intertek, the above-mentioned unit is in accordance with the applicable electromagnetic compatibility (EMC) portions of the requirements defined in FCC Part 27.

It is the manufacturer's responsibility to assure that additional production units of this model are manufactured with identical electrical and mechanical characteristics. Any modifications necessary for compliance made during testing on the above mentioned date(s) must be implemented in all production units for compliance to be maintained.

All testing was done in accordance with the Federal Communications Commission's CFR 47 Part 27. The EUT fulfills the requirements of the Federal Communications Commission's CFR 47 Part 27.

Date: 31 July, 2012

Location: Intertek Testing Services (INTERTEK)
7250 Hudson Blvd., Suite 100
Oakdale, MN 55128
Phone: (651) 730-1188
Fax: (651) 730-1282

ADC Telecommunications
1187 Park Place
Shakopee, MN 55379
Phone: (952) 403-8340
Fax: (952) 403-8858

Testing Conducted by (ADC):
And Report Written by:

Joshua J. Wittman
Compliance Engineer



EMC Emission – T E S T R E P O R T

Test Report File Number: MN120731 700P1 AWSP1 SRAU

Date of Issue: 31 June, 2012

Model Number(s): SPT-S2-70AWS-1-SISO

Product Name: Spectrum 700 Path 1/AWS Path1 SRAU

Product Type: Repeater

Applicant: ADC Telecommunications, Inc.

Manufacturer: ADC Telecommunications, Inc.

License Holder: ADC Telecommunications, Inc.

Address: P.O. Box 1101
Minneapolis, MN 55440-1101

Test Result: **Positive** Negative

Test Project Number: **100790006MIN-001**
Reference(s)

Total pages including Appendices: 137



1.0 TABLE OF CONTENTS

1.0	Table of Contents	3
2.0	Revision Description	4
3.0	Documentation	4
3.1	Test Regulations Results	4
3.2	Test Operation Mode	5
3.3	Configuration of the Device Under Test:	5
3.4	Product Options:	5
3.5	EUT Specifications and Requirements:	5
3.6	Cables:	5
3.7	Power Requirements:	5
3.8	Typical Installation and/or Operating Environment:	5
3.9	Other Special Requirements:	5
3.10	EUT Software:	5
3.11	EUT System Components	6
3.12	Support Equipment	6
3.13	Deviations from Standard:	6
3.14	General Remarks:	6
3.15	Summary:	6
4.0	Test Set-Up Drawings and Photos	7
4.1	Test Set-up Photo, Radiated Emissions	7
4.2	Test Set-up Drawings	8
5.0	Test Results	10
5.1.1	27.50 RF Power Limits	10
5.1.2	27.54 Frequency Stability	11
5.1.3	27.53 Emission Limitations	12
6.0	Test Equipment	13
7.0	Appendix A	14
7.1	Conducted Emission Limits Test	15
7.2	Conducted Output Power Test	63
7.3	Frequency Stability Test	66
7.4	Intermodulation Test	68
7.5	Occupied Bandwidth Modulation Test	120
8.0	Appendix B	135
9.0	Appendix C	137



2.0 REVISION DESCRIPTION

Rev	Total Pages	Date	Description
A	137	31 July, 2012	Original Release

3.0 DOCUMENTATION

3.1 Test Regulations

Results

27.50	Power limits	Pass
27.53	Emission limits	Pass
27.54	Frequency stability	Pass

The emissions tests were performed according to the following regulations:

- FCC Part 22
- FCC Part 24
- FCC Part 27**
- FCC Part 90
- IC RSS-131 Issue 2

Environmental Conditions in the lab:

ADC

Temperature: 25° C
Relative Humidity: 29%
Atmospheric Pressure: 98.0 kPa

Intertek

15-35° C
30-60%
86-106 kPa

Power Supply Utilized:

Power Supply System : 1 phase, 60 Hz, 120 VAC

3.2 Test Operation Mode

- Standby
- Test Program
- Practice Operation

■ Max composite in and out

3.3 Configuration of the Device Under Test:

Normal Operation – 700 – 728 to 756 MHz (728 to 746 MHz (Lower ABC) 746 to 756 MHz (Upper C))

Normal Operation – AWS – 2110 to 2155 MHz

3.4 Product Options:

None

3.5 EUT Specifications and Requirements:

Length: 11.50"

Width: 9.00"

Height: 3.50"

Weight: 7.49 pounds

3.6 Cables:

Cable Type	Length	From	To
RF	> 3M	Ancillary Equip	EUT
RF	< 3M	EUT	50 Ohm Load
Power (2)	< 3M	Power	Input Power (Ancillary)
Coax (75 Ohm)	> 3M	Ancillary Equip	EUT

3.7 Power Requirements:

Voltage: 54 VDC

3.8 Typical Installation and/or Operating Environment:

Indoor. System is typically employed as an indoor repeater.

3.9 Other Special Requirements:

None

3.10 EUT Software:

Revision Level: Version V.6 or greater

Description: Internet Explorer

3.11 EUT System Components

Description	Model #	Serial #	FCC ID #
Prism Host Unit	FWP-0000HUII	None	
Spectrum DRU	SPT-0000DRUII	None	
Spectrum IFEU	742735-0	None	
Spectrum Power Supply	LTPCPR1U3C-Z-527		
Remote Access Unit	<u>SPT-S2-70AWS-1-SISO</u>	None	

3.12 Support Equipment

Description	Manufacturer	Model #	FCC ID #
Power Meter	HP	437B	
Signal Generator	Agilent	8648C	

3.13 Deviations from Standard:

Modifications required to pass:

As indicated on the data sheet(s)

■ **None**

Test Specification Deviations; Additions to or Exclusions from:

As indicated in the Test Plan

■ **None**

3.14 General Remarks:

None.

3.15 Summary:

The requirements according to the technical regulations are

■ **met**

not Met

The equipment under test does

■ **fulfill the general approval requirements mentioned in Section 3.1.**

not fulfill the general approval requirements mentioned in Section 3.1.

4.0 TEST SET-UP DRAWINGS AND PHOTOS

[Table of Contents; Section 1.0](#)

4.1 Test Set-up Photo, Radiated Emissions

Reference Intertek Report: 100790006MIN-001

4.2 Test Set-up Drawings

Conducted and Radiated Emission Limits Test

Conducted Output Power Test

Inter-Modulation Test

Occupied Bandwidth Modulation Test

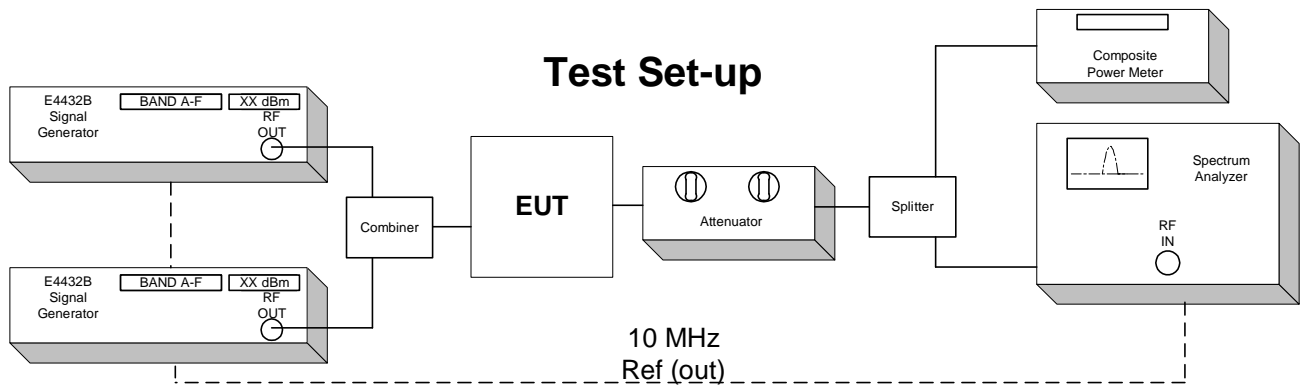

Frequency Tolerance Test

The Host, DRU, and IFEU EUT are specified for indoor use with temperature range of 0° to +50° C, and were tested within their range.

The Remote Access Unit EUT is specified for indoor use with temperature range of -25° to +50° C, and was tested with its range.

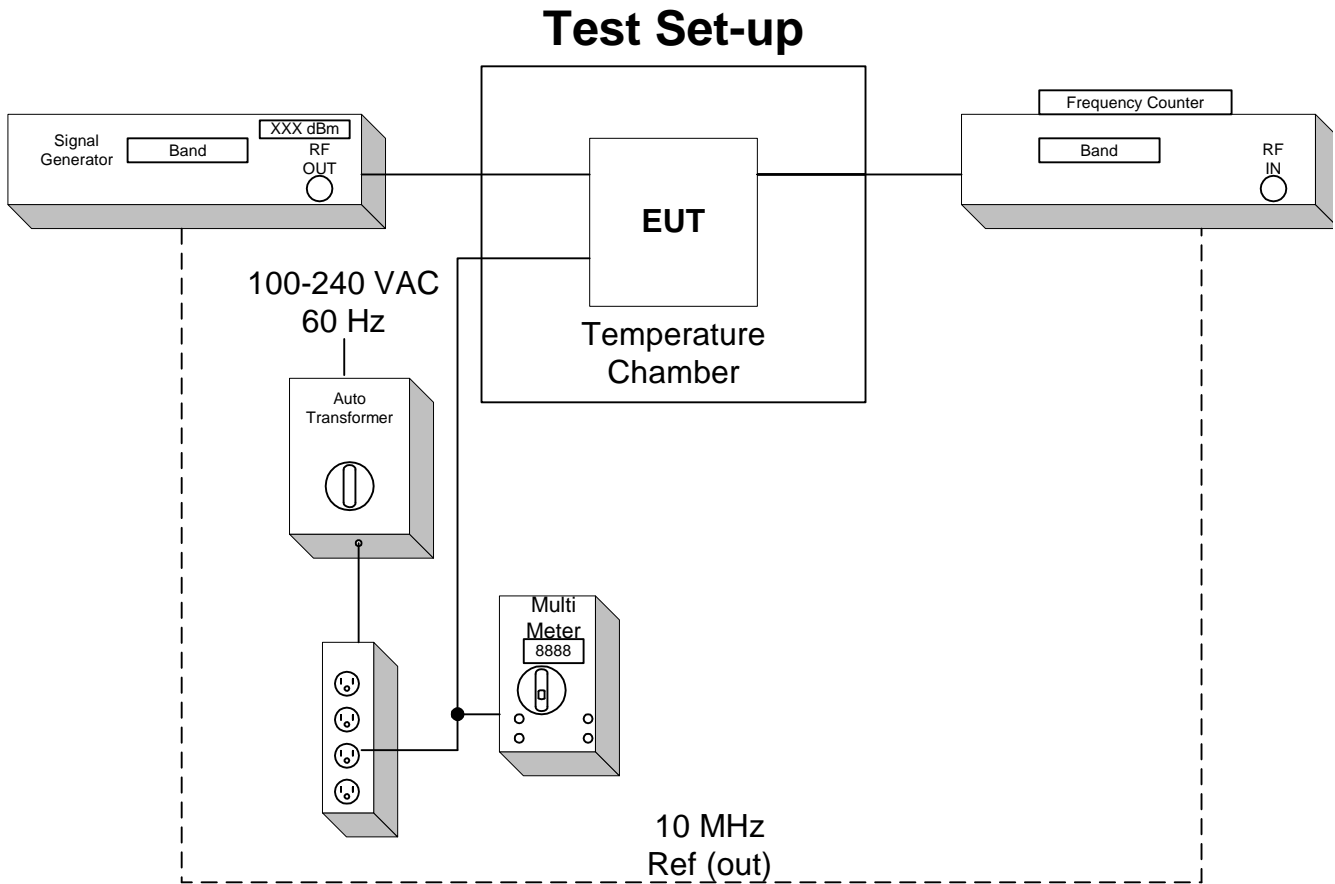

5.0 TEST RESULTS

5.1.1 27.50 RF Power Limits

Test Summary:

- The requirements are: **MET** NOT MET
- Minimum margin of compliance is 20.22 dB at 737.0 MHz(LTE 1.4MHz)(LowerABC)(Path1)
- Minimum margin of compliance is 21.10 dB at 737.0 MHz(LTE 3 MHz)(LowerABC)(Path1)
- Minimum margin of compliance is 20.44 dB at 737.0 MHz(LTE 5 MHz)(LowerABC)(Path1)
- Minimum margin of compliance is 19.90 dB at 737.0 MHz(LTE 10 MHz)(LowerABC)(Path1)
- Minimum margin of compliance is 19.80 dB at 751.5 MHz(LTE 1.4 MHz)(UpperC)(Path1)
- Minimum margin of compliance is 20.45 dB at 751.5 MHz(LTE 3 MHz)(UpperC)(Path1)
- Minimum margin of compliance is 19.40 dB at 748.5 MHz(LTE 5 MHz)(UpperC)(Path1)
- Minimum margin of compliance is 19.26 dB at 751.5 MHz(LTE 10 MHz)(UpperC)(Path1)
- Minimum margin of compliance is 20.09 dB at 2112.5 MHz (W-CDMA) (Path 1)
- Minimum margin of compliance is 20.12 dB at 2111.5 MHz (LTE 3MHz) (Path 1)
- Minimum margin of compliance is 19.17 dB at 2112.5 MHz (LTE 5MHz) (Path 1)
- Minimum margin of compliance is 19.73 dB at 2115.0 MHz (LTE 10MHz) (Path 1)
- Minimum margin of compliance is 19.46 dB at 2117.5 MHz (LTE 15MHz) (Path 1)
- Minimum margin of compliance is 19.11 dB at 2120.0 MHz (LTE 20MHz) (Path 1)

Test Location:

INTERTEK (Oakdale, MN)

ADC facility (Shakopee, MN)

Test Distance:

3 Meters

10 Meters

Conducted measurement

Test Equipment (ADC):

1, 2, 6, 7, 12

Test Limit:

100 Watts or 50 dBm Limit

Test Data:

[Conducted Output Power; Section 7.2](#)

[Table of Contents; Section 1.0](#)

Test Engineer: Joshua J. Wittman

Date: 25 June, 2012

11 July, 2012

5.1.2 27.54 Frequency Stability

Test Summary:

- The requirements are: **MET** NOT MET
- The fundamental emission stays within the limit.
- Frequency measured over a temperature range of -25 to 50° C and an input voltage range of 100 to 240 VAC.

Test Location:

INTERTEK (Oakdale, MN)

ADC facility (Shakopee, MN)

Test Equipment (ADC):

3, 4, 5, 6, 9,11,12

Test Limit:

The frequency stability shall be sufficient to ensure that the fundamental emission stays within the authorized frequency block.

Test Data:

[Frequency Stability; Section 7.3](#)

[Table of Contents; Section 1.0](#)

Test Engineer: Joshua J. Wittman

Date: 26 June, 2012

13 July, 2012

5.1.3 27.53 Emission Limitations

Test Summary:

- The requirements are: ■ **MET** □ NOT MET
- Out of band emissions were less than -13 dBm.
- Outside the emission bandwidth of the carrier, all emissions are attenuated at least 26 dB below the transmitter power.

Test Location:

□ INTERTEK (Oakdale, MN)

■ **ADC facility (Shakopee, MN)**

Test Equipment (ADC):

1, 2, 6, 7, 12, 13

Test Limit:

Out of band emissions:

Attenuated below the transmitting power (P) by a factor of at least $43 + 10\log(P)$ dB, or -13 dBm.

Outside of the carrier emissions bandwidth:

26 dB below the transmitter power

Test Data:

[Conducted Emissions; Section 7.1](#)

[Intermodulation; Section 7.4](#)

[Occupied Bandwidth; Section 7.5](#)

Radiated Emissions; ([Appendix B](#))

[Table of Contents; Section 1.0](#)

Test Engineer: Joshua J. Wittman

Date: 25, 28 June, 2012 & 11, 12 July, 2012

Date: 27, 28 June, 2012 & 13 July, 2012

Date: 27 June, 2012 & 12 July, 2012

6.0 TEST EQUIPMENT

[Table of Contents; Section 1.0](#)

Number	Description	Manufacturer	Model	ADC TELECOMMUNICATIONS Serial Number	Cal Due	Used
1	Spectrum Analyzer	HP	8563E	MC27690	6-30-13	<input checked="" type="checkbox"/>
2	Power Meter	HP	437B	MC27754	6-30-13	<input checked="" type="checkbox"/>
3	Multimeter	Fluke	79	MC18758	6-30-13	<input checked="" type="checkbox"/>
4	Frequency Counter	HP	5347A	MC27569	6-30-13	<input checked="" type="checkbox"/>
5	Temperature Chamber	ESPEC	PSL-4G	MC10075	9-8-12	<input checked="" type="checkbox"/>
6	Signal Generator	Aeroflex	3413	MC57343	11-9-12	<input checked="" type="checkbox"/>
7	Signal Generator	Aeroflex	3414	341001/259	6-13-13	<input checked="" type="checkbox"/>
8	Variable Auto Transformer	Staco	1520CT	MC44655	CNR	<input checked="" type="checkbox"/>
9	Digital Barometer	Fisher Scientific	02-403	MC50719	1-25-13	<input checked="" type="checkbox"/>
10	Attenuator	Aeroflex	49-30-33	N/A	CNR	<input checked="" type="checkbox"/>
11	Attenuator	Aeroflex	86-30-12	N/A	CNR	<input checked="" type="checkbox"/>
12	RF Power Sensor	Agilent	8481A	MC27649	6-30-13	<input checked="" type="checkbox"/>
13	Spectrum Analyzer	Rohde & Schwarz	FSQ-8	MC57131	2-15-13	<input checked="" type="checkbox"/>

Equipment with a Calibration Not Required (CNR) listing is verified and compensated for with NIST traceable calibrated equipment.

7.0

APPENDIX A

Conducted Emissions Test Data

[Table of Contents; Section 1.0](#)

Test Engineer: Joshua J. Wittman

7.1 Conducted Emission Limits Test

[Table of Contents; Section 1.0](#)

[Back to Emission Limits; Section 5.1.3](#)

The out of band emissions were measured directly from the EUT antenna output in the TX path using a spectrum analyzer from 30 MHz to the 10th harmonic of the highest carrier frequency. Test signals used are LTE 1.4 MHz, 3 MHz, 5MHz, 10MHz, 15MHz, 20 MHz Channel Bandwidths & WCDMA. The different signals were input one at a time to the EUT. In all cases, the out of band emissions were less than -13 dBm from the equation

$$(19\text{dBm} - [43 + 10\log(0.08\text{W})])$$

Band edge compliance is also demonstrated using a LTE 1.4 MHz, 3 MHz, 5MHz, 10MHz, 15MHz, 20MHz Channel Bandwidths & WCDMA signal at the upper and lower limits of the band.

The Prism Host, Spectrum DRU, and Spectrum IFEU are Part 15 devices and have been tested and are compliant as such.

Industry practice has generally set the input signal power level. Test signal used was \approx -11 dBm input to Prism Host in the TX Path.

Industry practice has generally set the output signal power level.

Prism Host:	Spectrum DRU:	Spectrum IFEU	Remote Access Unit(RAU):
Range: 21 - 60 VDC	Range: 21 - 60 VDC	Range: 54 VDC	Range: 54 VDC
Tested @: 54 VDC	Tested @: 54 VDC	Tested @: 54 VDC	Tested @: 54 VDC

Application details for 2.1033(c)(10), and 2.1033(c)(13):

Final RF Amplifier Input DC Voltage and Current: 7.3V at 400mA

PLL creates all the Local Oscillators that convert signal to IF and RF signals. When PLL is unlocked the band is shut down, this is to avoid transmission of any incorrect frequency.

Internal to the electronics, the use of SAW filters provides for higher Q roll-off at band edges.

This equipment does not modulate the RF, so there is no modulation limiter. This equipment does not change the modulation of the RF or the occupied bandwidth of any channel. It transports the signal, as is, over TV (IF) coax cable. The RF input is not changed in the RF output.

This is a constant gain device, so the setup controls the output. There is an overdrive and overpower limit control that prevents excess power.

Results:

Pass (See plots)

Conducted Emissions

LTE 1.4 MHz Channel Bandwidth

Spectrum 700 MHz

Center: 737 MHz

Lower ABC Path 1

Span: 5 MHz

RBW/VBW: 100 kHz

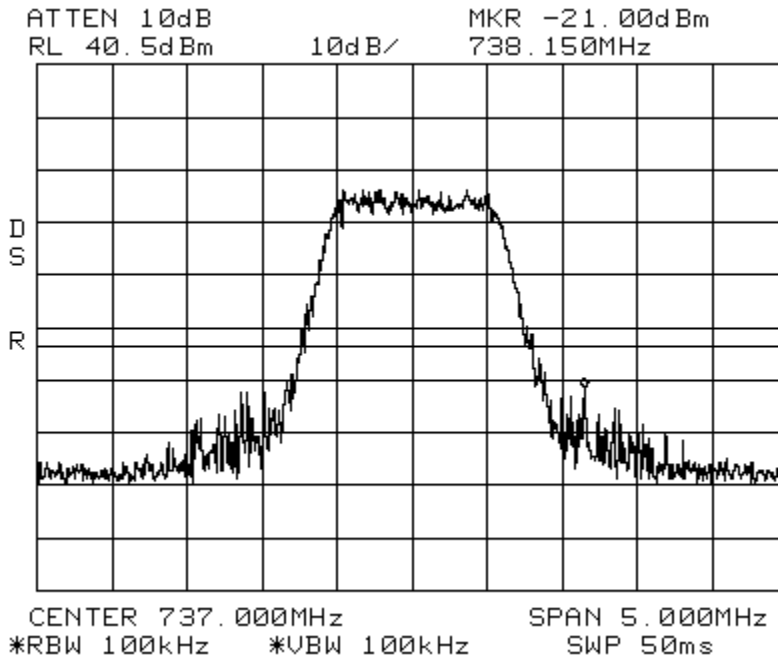

Conducted Emissions

LTE 1.4 MHz Channel Bandwidth

Spectrum 700 MHz

Span: 30 MHz to 1 GHz

Lower ABC Path 1

RBW/VBW: 300 kHz

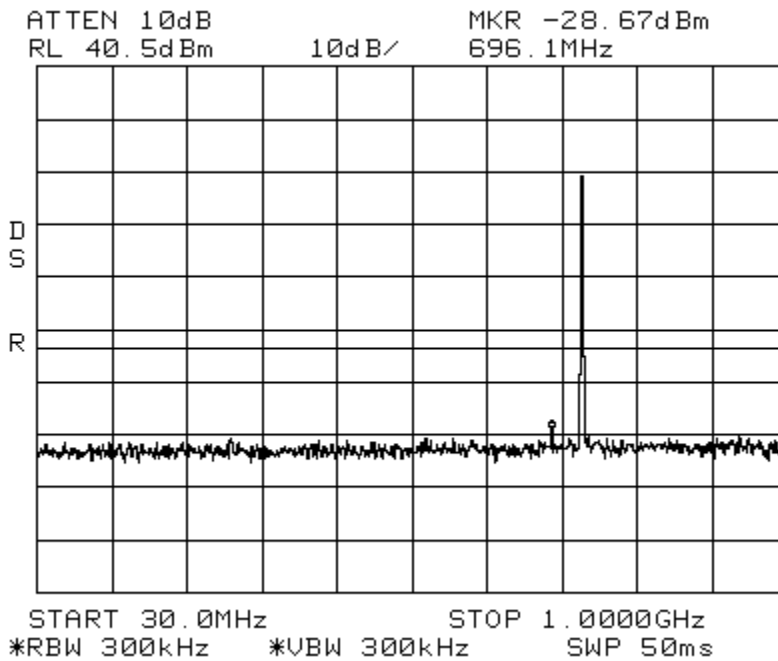

Conducted Emissions

LTE 1.4 MHz Channel Bandwidth
Lower ABC Path 1

Spectrum 700 MHz

Span: 1 GHz to 10 GHz

RBW/VBW: 1 MHz

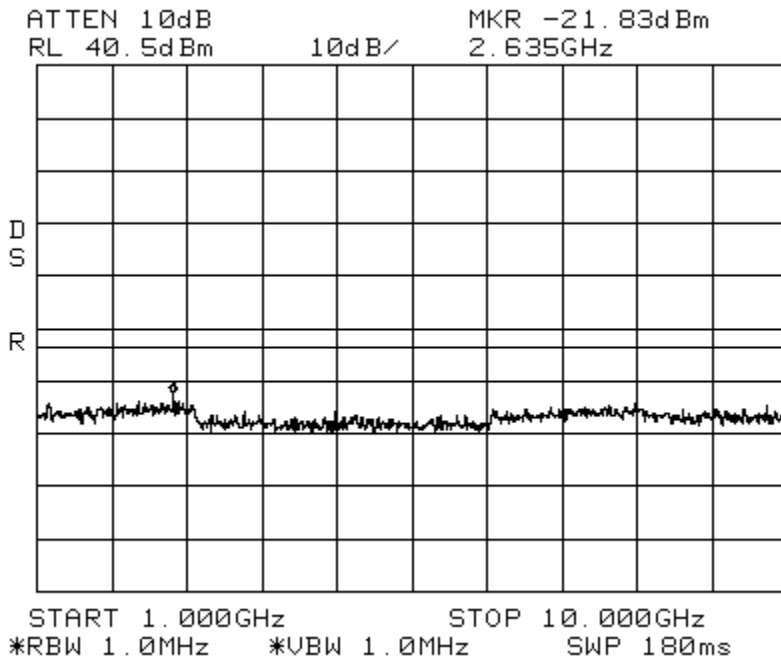

Conducted Emissions

LTE 3 MHz Channel Bandwidth
Lower ABC Path 1

Spectrum 700 MHz

Center: 737 MHz

Span: 5 MHz

RBW/VBW: 100 kHz

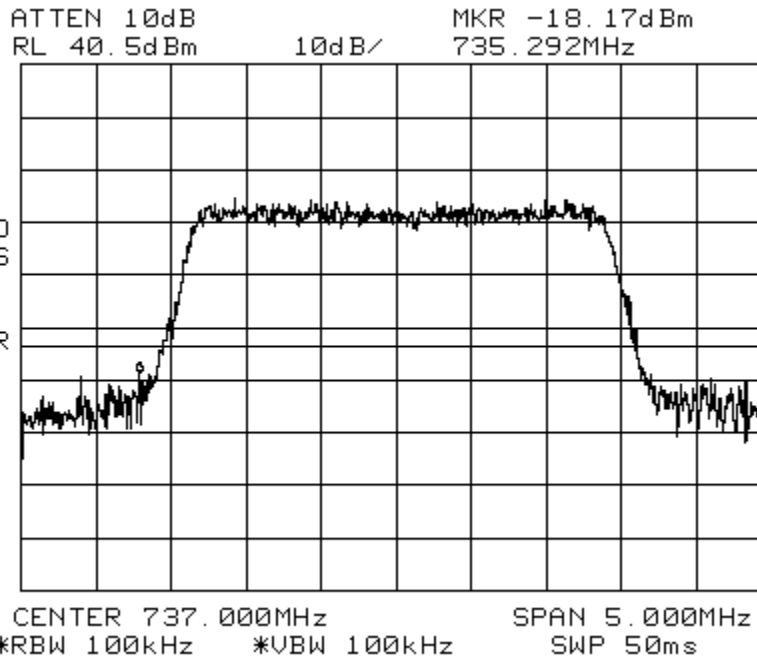

Conducted Emissions

LTE 3 MHz Channel Bandwidth
Lower ABC Path 1

Spectrum 700 MHz

Span: 30 MHz to 1 GHz

RBW/VBW: 300 kHz

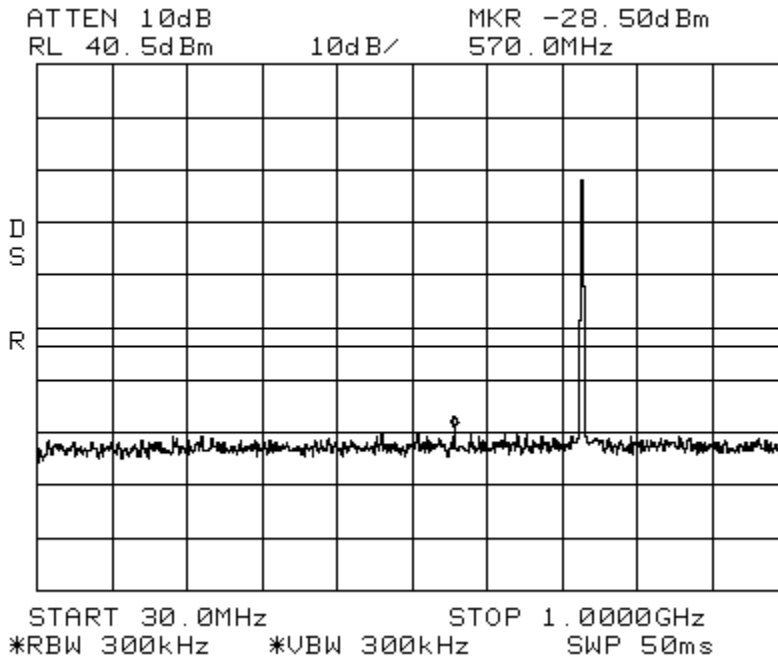

Conducted Emissions

LTE 3 MHz Channel Bandwidth
Lower ABC Path 1

Spectrum 700 MHz

Span: 1 GHz to 10 GHz

RBW/VBW: 1 MHz

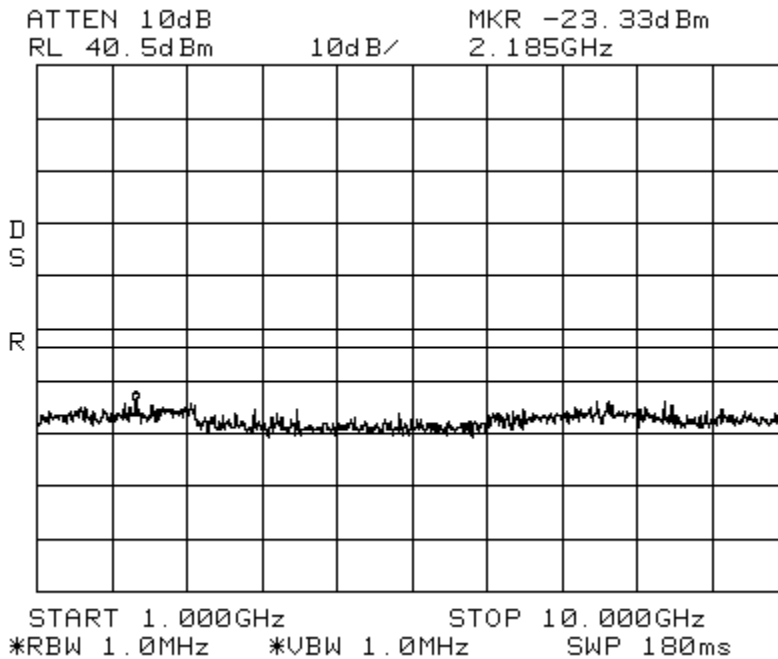

Conducted Emissions

LTE 5 MHz Channel Bandwidth

Spectrum 700 MHz

Center: 737 MHz Lower ABC Path 1 Span: 10 MHz RBW/VBW: 100 kHz
ATTEN 10dB MKR -20.00dBm
RL 40.5dBm 10dB/ 733.68MHz

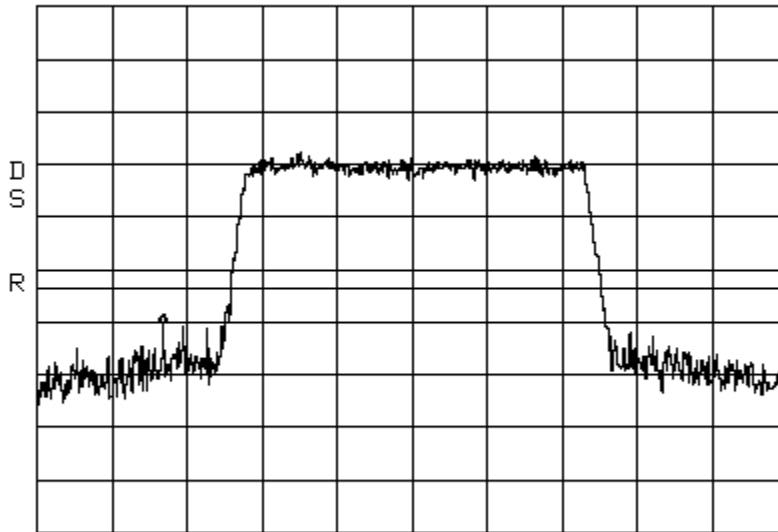

CENTER 737.00MHz SPAN 10.00MHz
*RBW 100kHz *VBW 100kHz SWP 50ms

Conducted Emissions

LTE 5 MHz Channel Bandwidth

Spectrum 700 MHz

Lower ABC Path 1
Span: 30 MHz to 1 GHz RBW/VBW: 300 kHz

ATTEN 10dB MKR -28.83dBm
RL 40.5dBm 10dB/ 607.2MHz

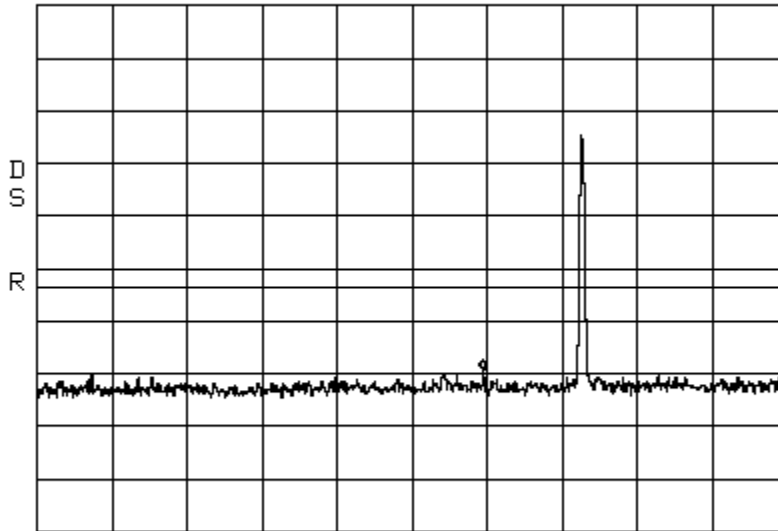

START 30.0MHz STOP 1.0000GHz
*RBW 300kHz *VBW 300kHz SWP 50ms

Conducted Emissions

LTE 5 MHz Channel Bandwidth
Lower ABC Path 1

Spectrum 700 MHz

Span: 1 GHz to 10 GHz

RBW/VBW: 1 MHz

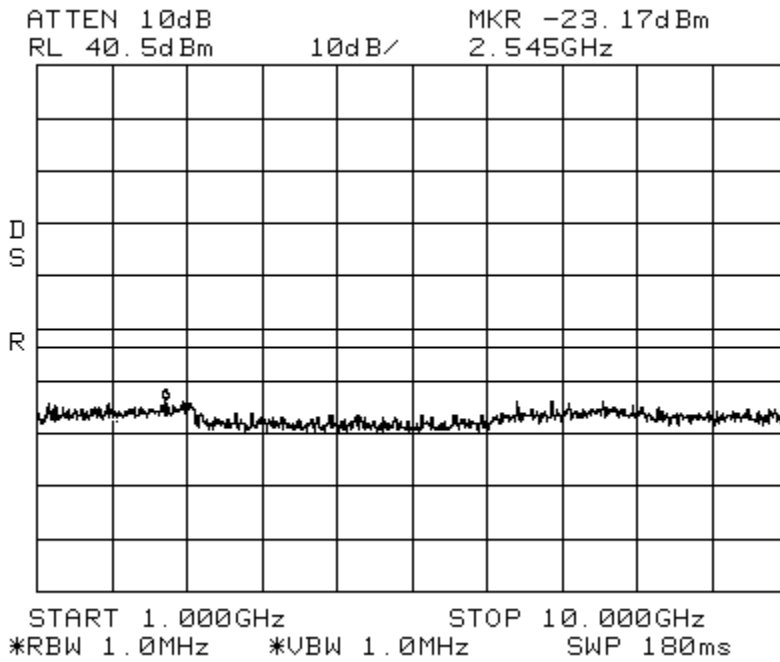

Conducted Emissions

LTE 10 MHz Channel Bandwidth
Lower ABC Path 1

Spectrum 700 MHz

Center: 737 MHz

Span: 20MHz

RBW/VBW: 100 kHz

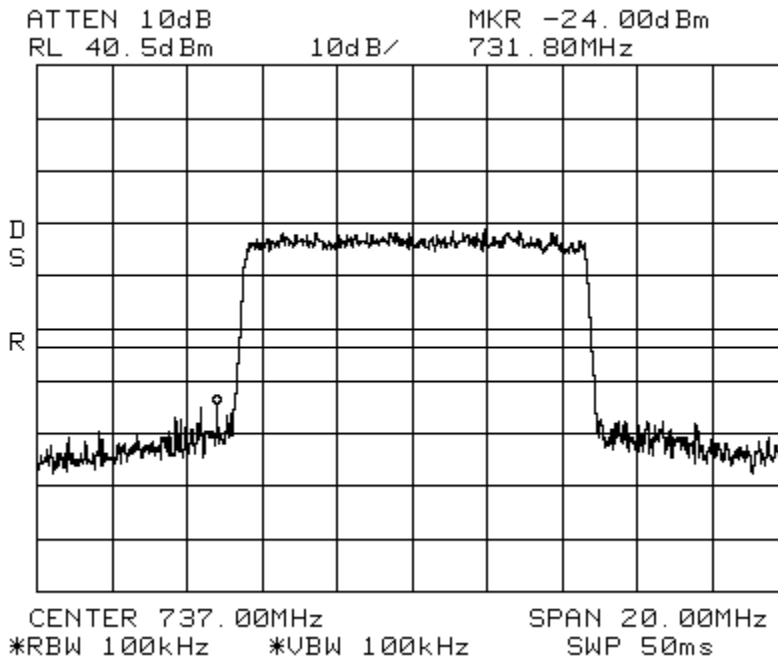

Conducted Emissions

LTE 10 MHz Channel Bandwidth
Lower ABC Path 1

Spectrum 700 MHz

Span: 30 MHz to 1 GHz

RBW/VBW: 300 kHz

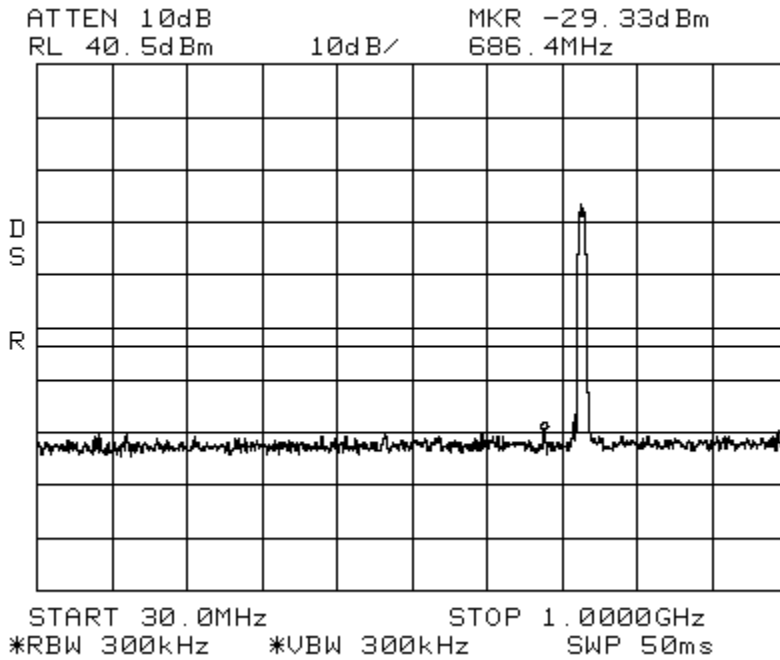

Conducted Emissions

LTE 10 MHz Channel Bandwidth
Lower ABC Path 1

Spectrum 700 MHz

Span: 1 GHz to 10 GHz

RBW/VBW: 1 MHz

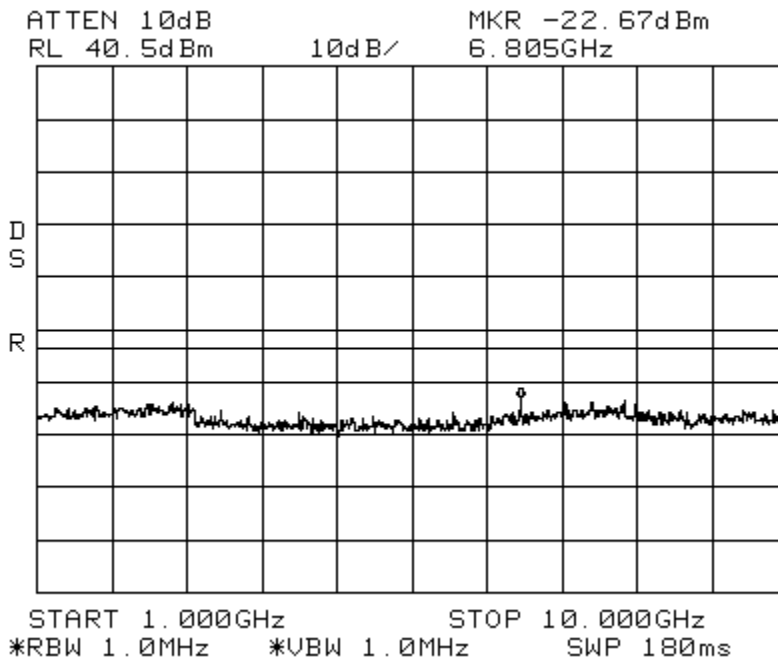

Conducted Emissions

LTE 1.4 MHz Channel Bandwidth

Spectrum 700 MHz

Upper C Path 1

Center: 751.5 MHz

Span: 5 MHz

RBW/VBW: 100 kHz

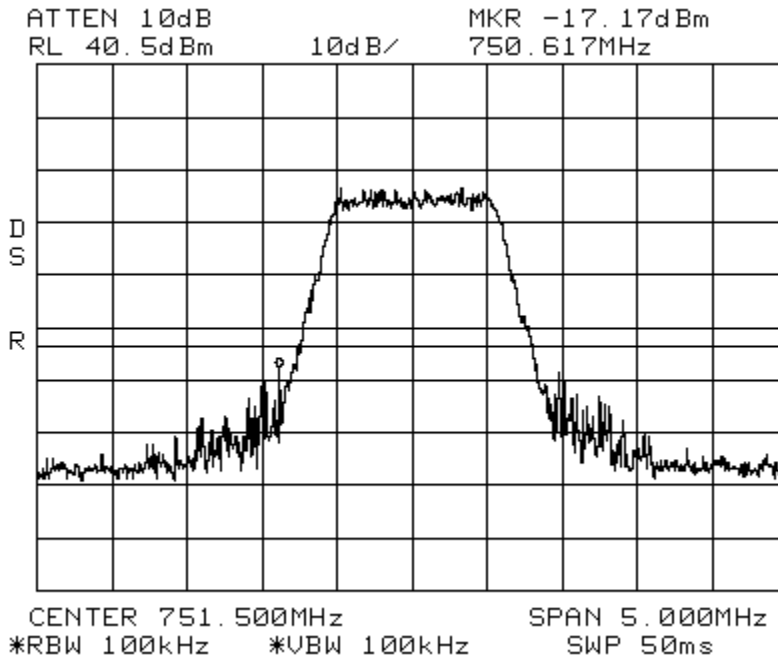

Conducted Emissions

LTE 1.4 MHz Channel Bandwidth

Spectrum 700 MHz

Upper C Path 1

Span: 30 MHz to 1 GHz

RBW/VBW: 300 kHz

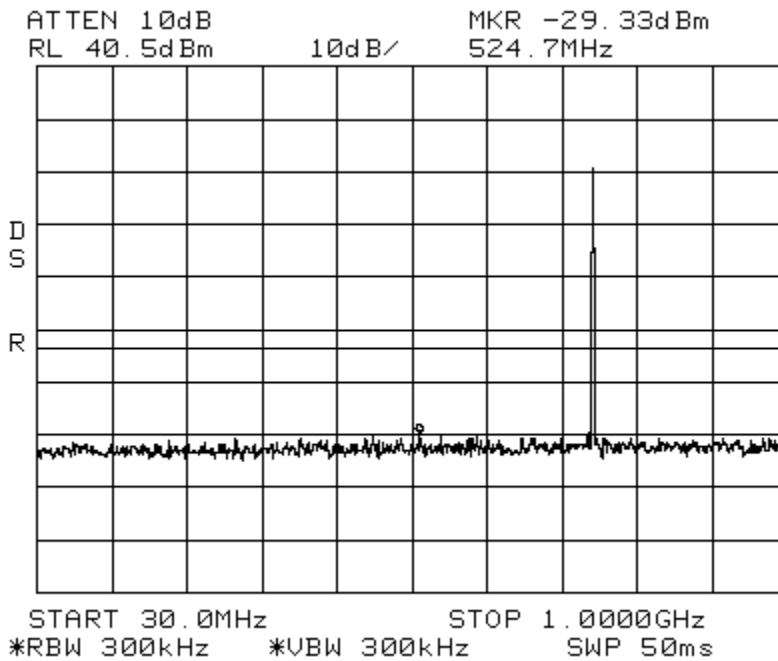

Conducted Emissions

LTE 1.4 MHz Channel Bandwidth
Upper C Path 1

Spectrum 700 MHz

Span: 1 GHz to 10 GHz

RBW/VBW: 1 MHz

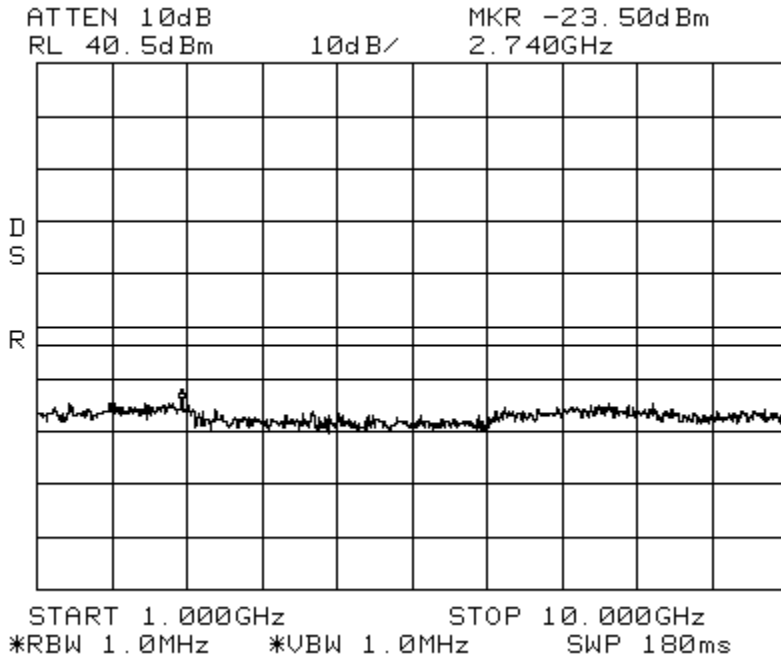

Conducted Emissions

LTE 3 MHz Channel Bandwidth
Upper C Path 1

Spectrum 700 MHz

Center: 751 MHz

Span: 5 MHz

RBW/VBW: 100 kHz

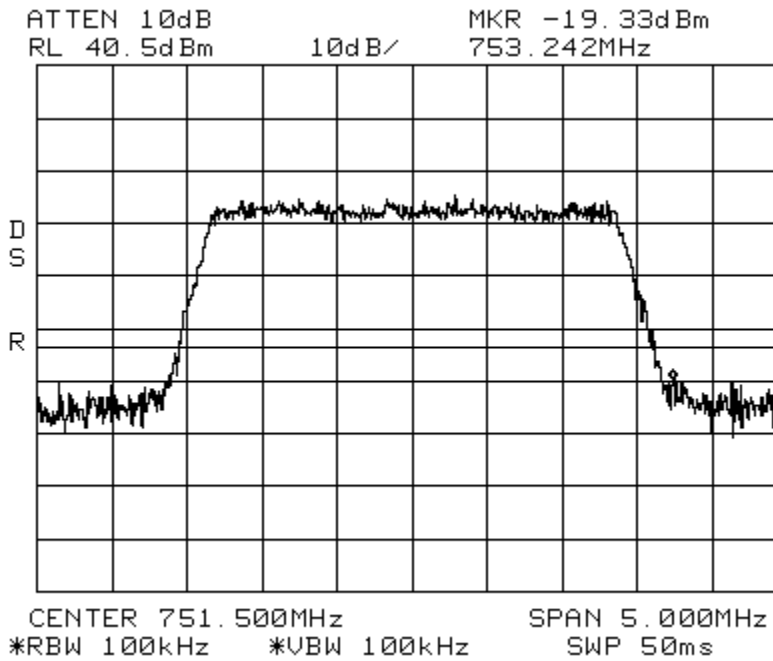

Conducted Emissions

LTE 3 MHz Channel Bandwidth
Upper C Path 1

Spectrum 700 MHz

Span: 30 MHz to 1 GHz

RBW/VBW: 300 kHz

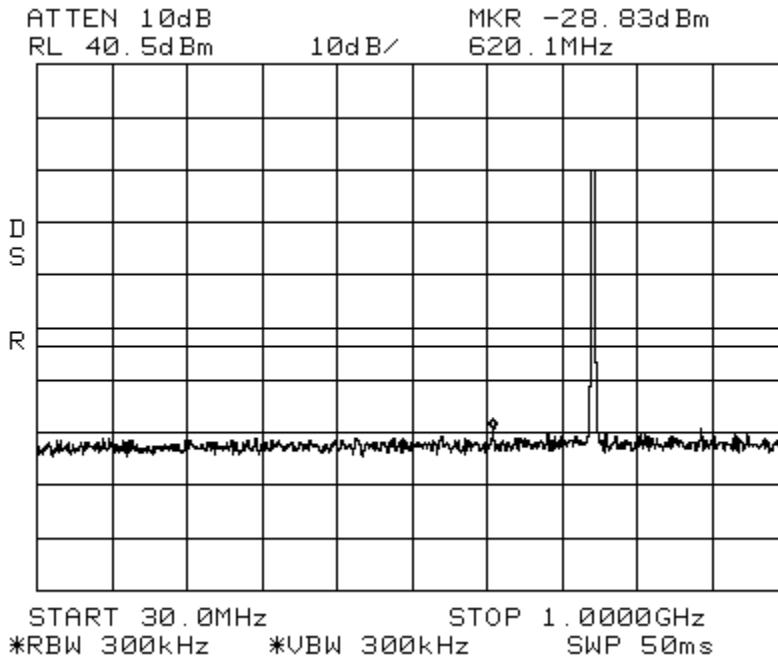

Conducted Emissions

LTE 3 MHz Channel Bandwidth
Upper C Path 1

Spectrum 700 MHz

Span: 1 GHz to 10 GHz

RBW/VBW: 1 MHz

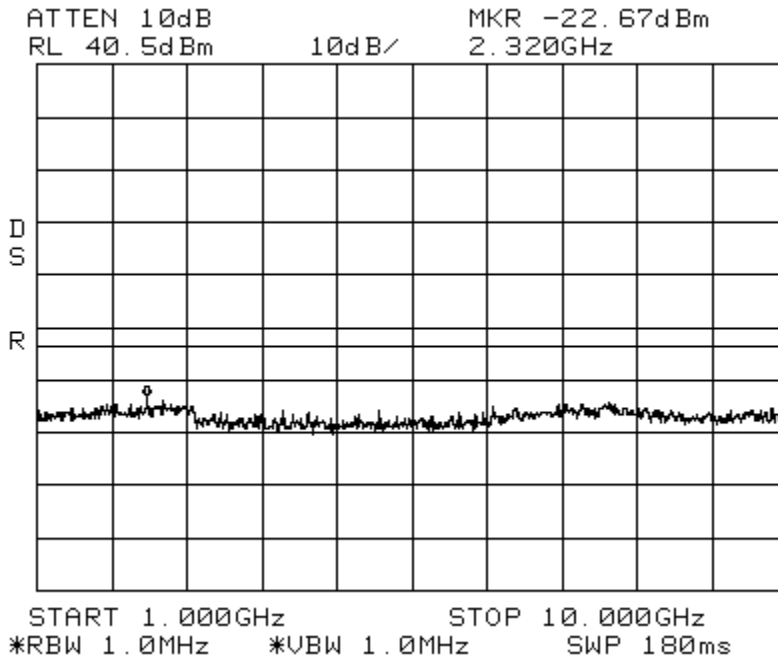

Conducted Emissions

LTE 5 MHz Channel Bandwidth

Spectrum 700 MHz

Upper C Path 1

Center: 751.5 MHz

Span: 10 MHz

RBW/VBW: 100 kHz

ATTEN 10dB

MKR -20.67dBm

RL 40.5dBm

10dB/

748.95MHz

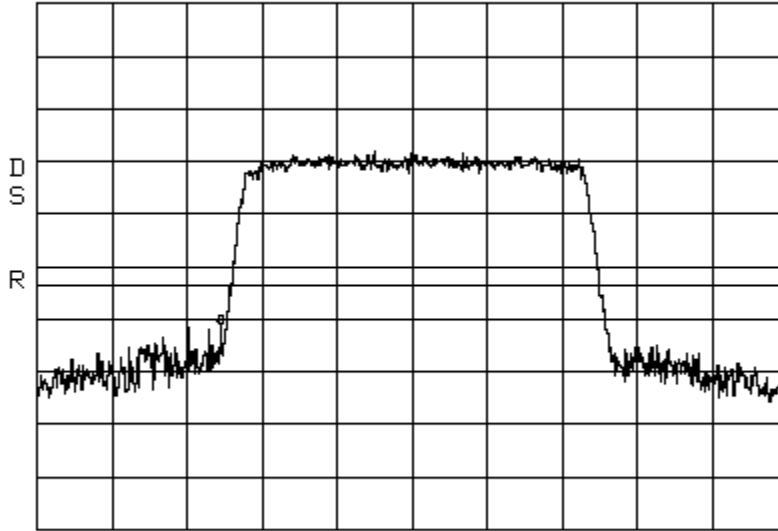

CENTER 751.50MHz SPAN 10.00MHz
*RBW 100kHz *VBW 100kHz SWP 50ms

Conducted Emissions

LTE 5 MHz Channel Bandwidth

Spectrum 700 MHz

Upper C Path 1

Span: 30 MHz to 1 GHz

RBW/VBW: 300 kHz

ATTEN 10dB

MKR -29.67dBm

RL 40.5dBm

10dB/

495.6MHz

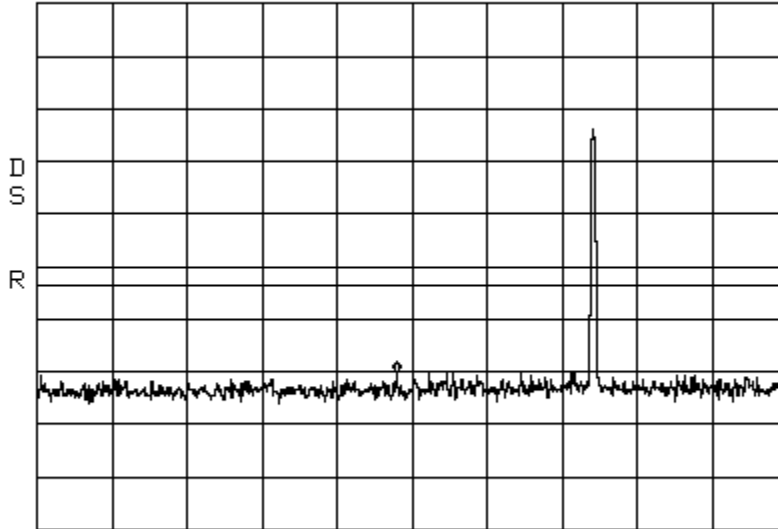

START 30.0MHz STOP 1.0000GHz
*RBW 300kHz *VBW 300kHz SWP 50ms

Conducted Emissions

LTE 5 MHz Channel Bandwidth
Upper C Path 1

Spectrum 700 MHz

Span: 1 GHz to 10 GHz

RBW/VBW: 1 MHz

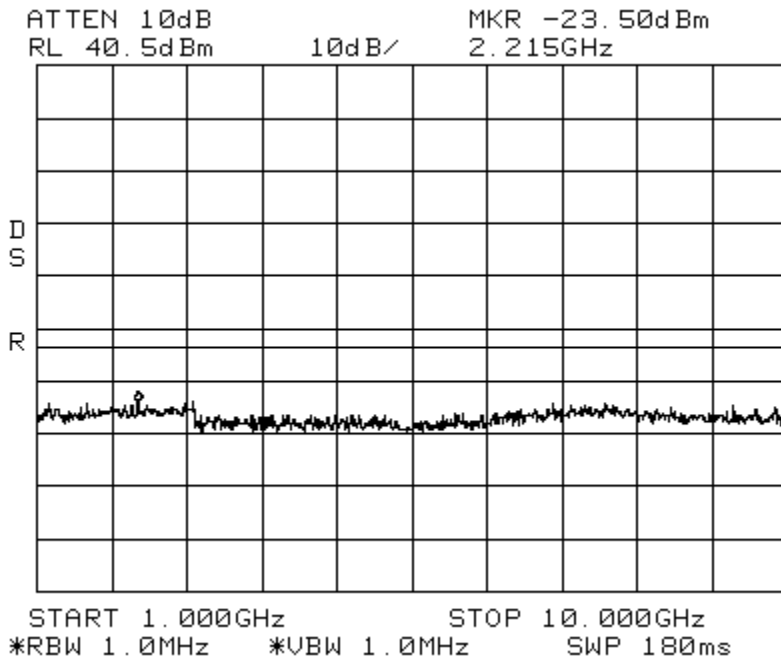

Conducted Emissions

LTE 10 MHz Channel Bandwidth
Upper C Path 1

Spectrum 700 MHz

Center: 751.5 MHz

Span: 20MHz

RBW/VBW: 100 kHz

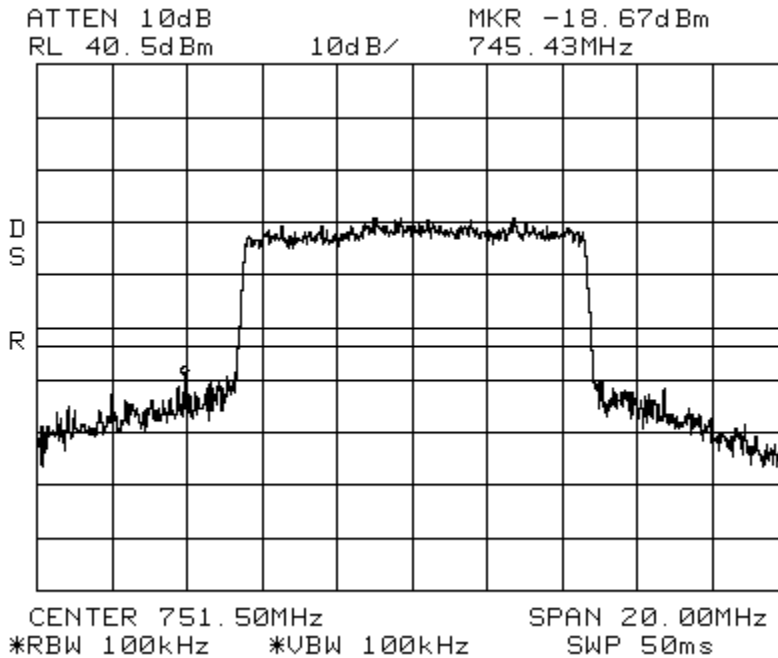

Conducted Emissions

LTE 10 MHz Channel Bandwidth
Upper C Path 1

Spectrum 700 MHz

Span: 30 MHz to 1 GHz

RBW/VBW: 300 kHz

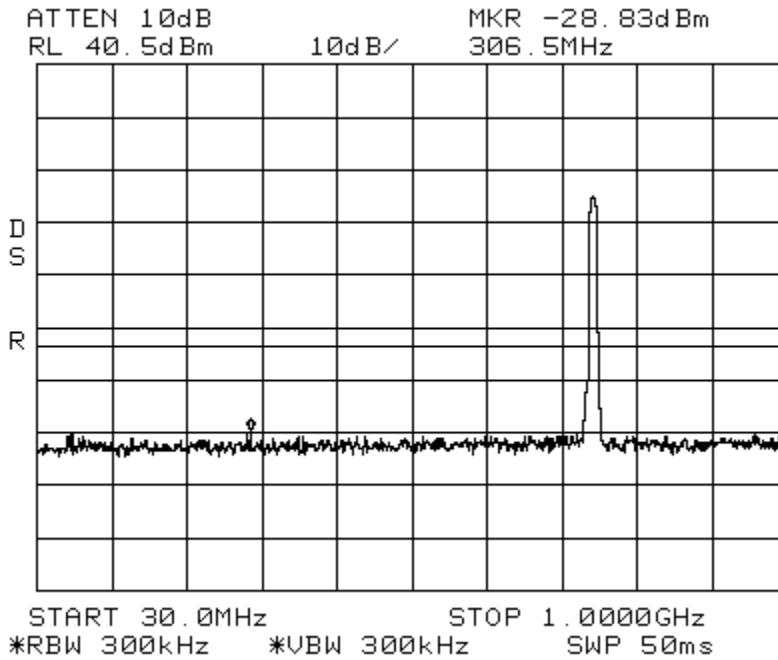

Conducted Emissions

LTE 10 MHz Channel Bandwidth
Upper C Path 1

Spectrum 700 MHz

Span: 1 GHz to 10 GHz

RBW/VBW: 1 MHz

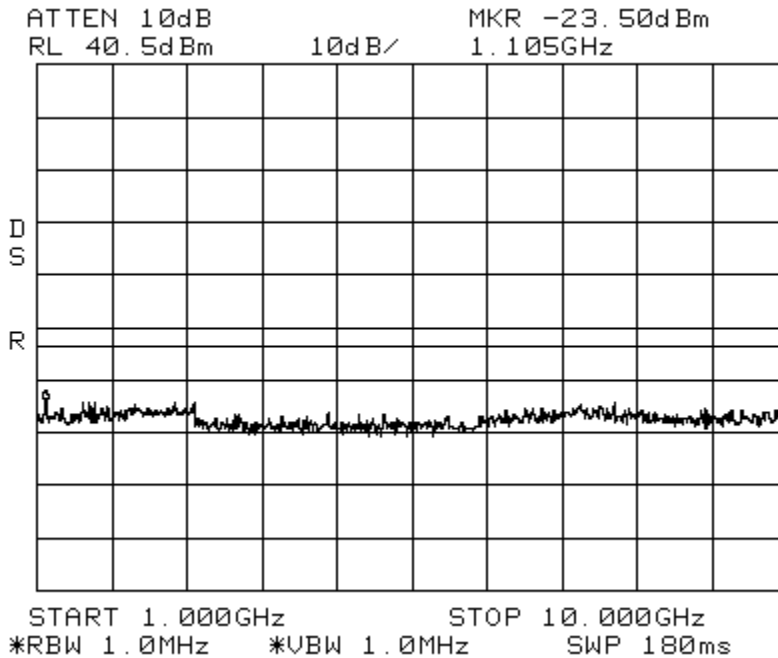

Conducted Emissions LTE 1.4 MHz Channel Bandwidth Spectrum 700 MHz Path 1
Start 763 MHz Stop 775 MHz RBW 6.0kHz VBW 20 kHz



* RBW 6.0 kHz Marker 1 [T1]
* VBW 20.0 kHz -63.03 dBm

Ref 20.0 dBm Att 9 dB SWT 28 s 770.076923077 MHz

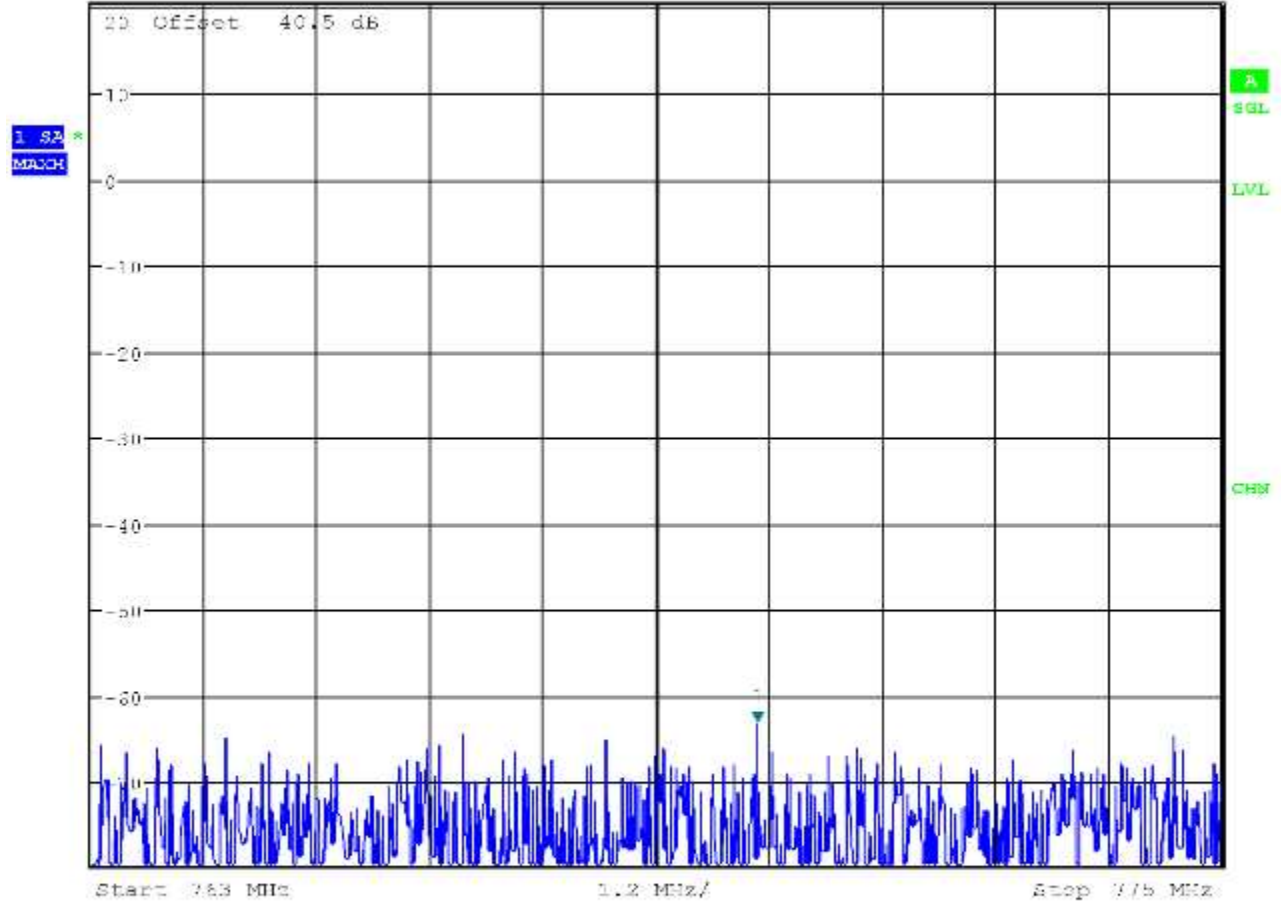

Date: 28.JUN.2012 14:26:28

Conducted Emissions LTE 1.4 MHz Channel Bandwidth Spectrum 700 MHz Path 1
Start 793 MHz Stop 805 MHz RBW 6.0kHz VBW 20 kHz



* RBW 6.0 kHz Marker 1 [T1]
* VBW 20.0 kHz -63.03 dBm

Ref 20.0 dBm Att 9 dB SWT 28 s 793.057692308 MHz

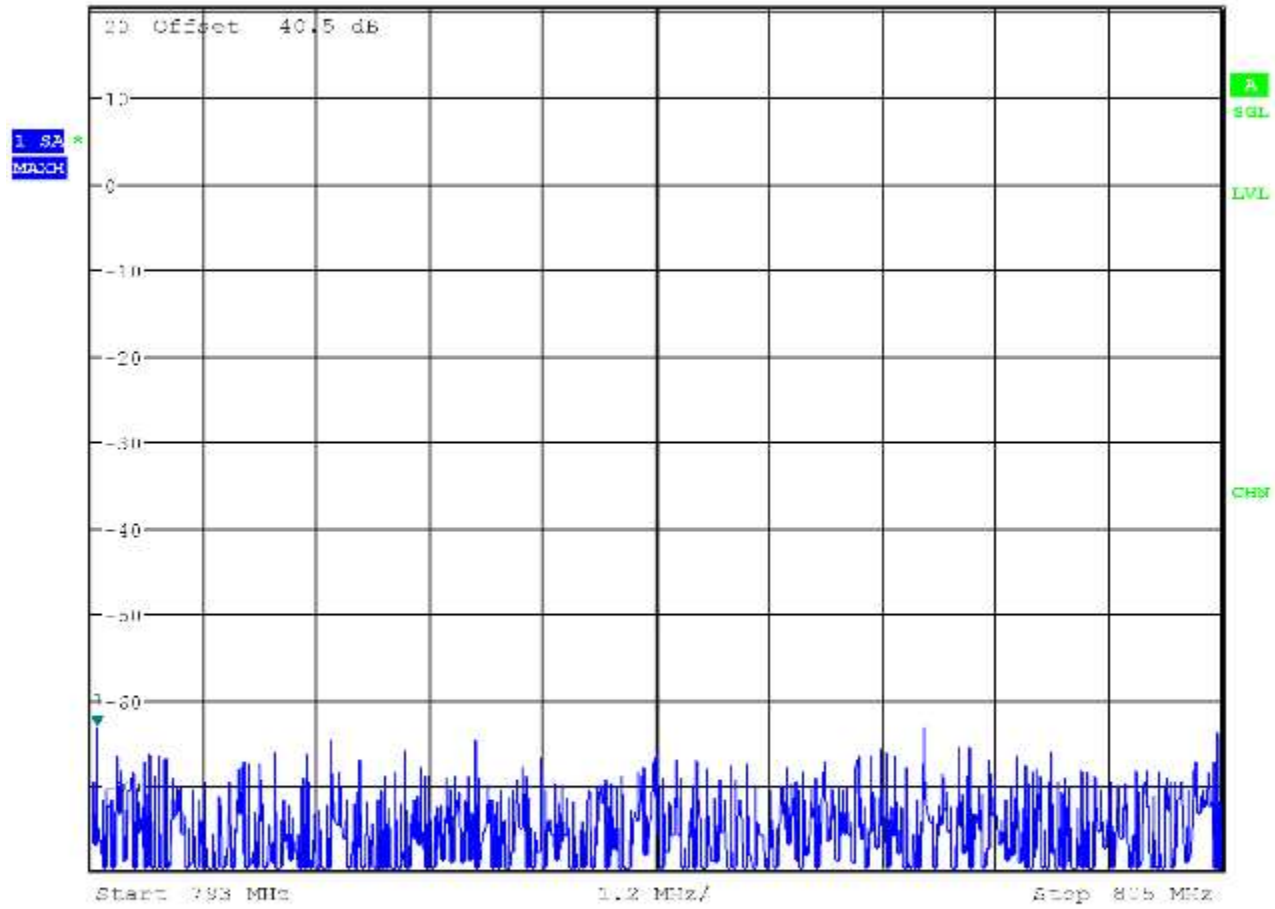

Date: 28.JUN.2012 14:57:13

Conducted Emissions LTE 1.4 MHz Channel Bandwidth Spectrum 700 MHz Path 1
Start 1559 MHz Stop 1610 MHz RBW 6.0kHz VBW 20 kHz



* RBW: 6.0 kHz * Marker 1 [T1] -63.66 dBm
* VBW: 20.0 kHz
Ref: 20.0 dBm Att: 9 dB SWT: 290 s 1.572485577 GHz

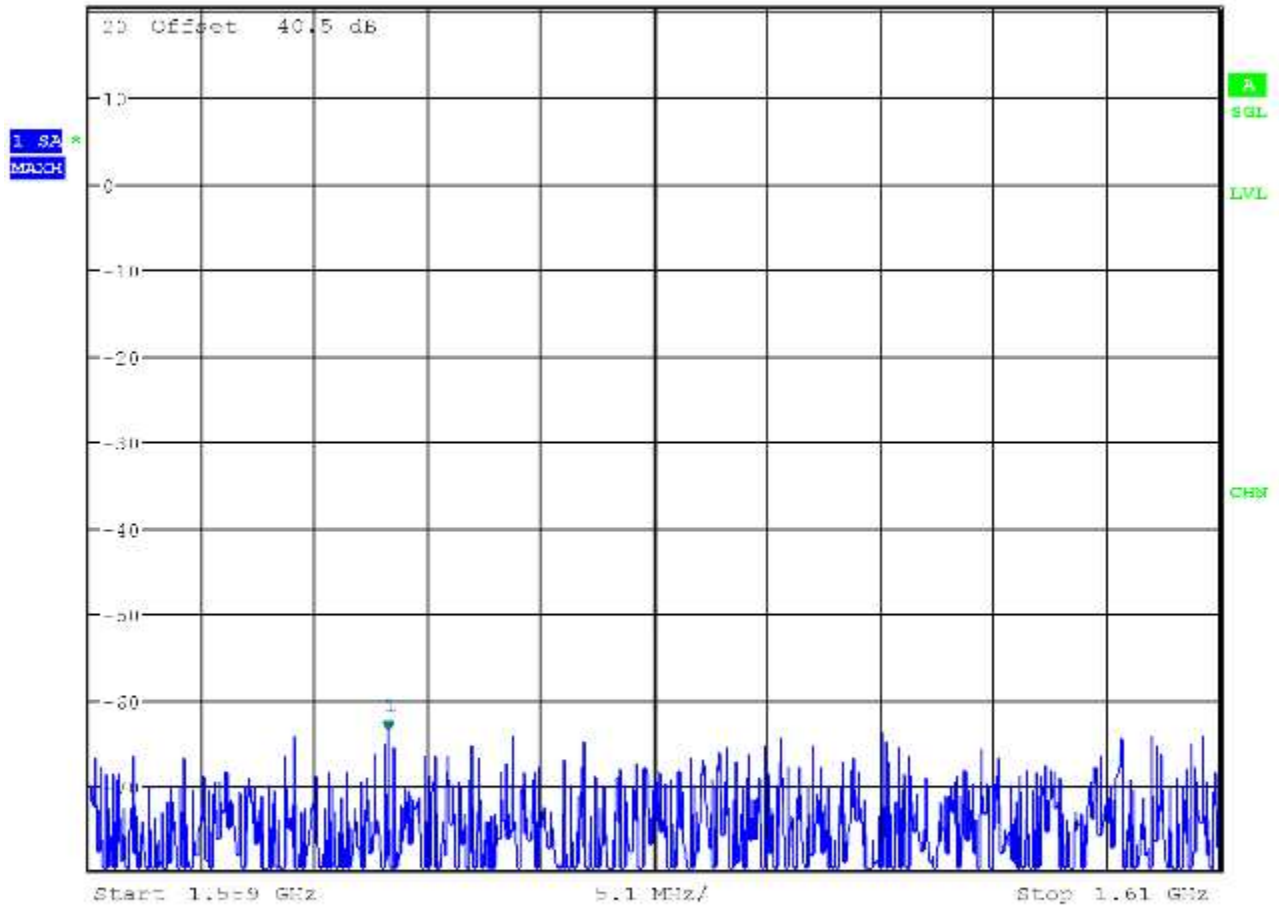

Date: 28.JUN.2012 15:31:43

Conducted Emissions LTE 3.0 MHz Channel Bandwidth Spectrum 700 MHz Path 1
Start 763 MHz Stop 775 MHz RBW 6.0kHz VBW 20 kHz



*RBW 6 kHz Marker 1 [T1]
*VBW 20 kHz -71.31 dBm
Ref 20.0 dBm Att 9 dB SWT 88 s 766.653846154 MHz

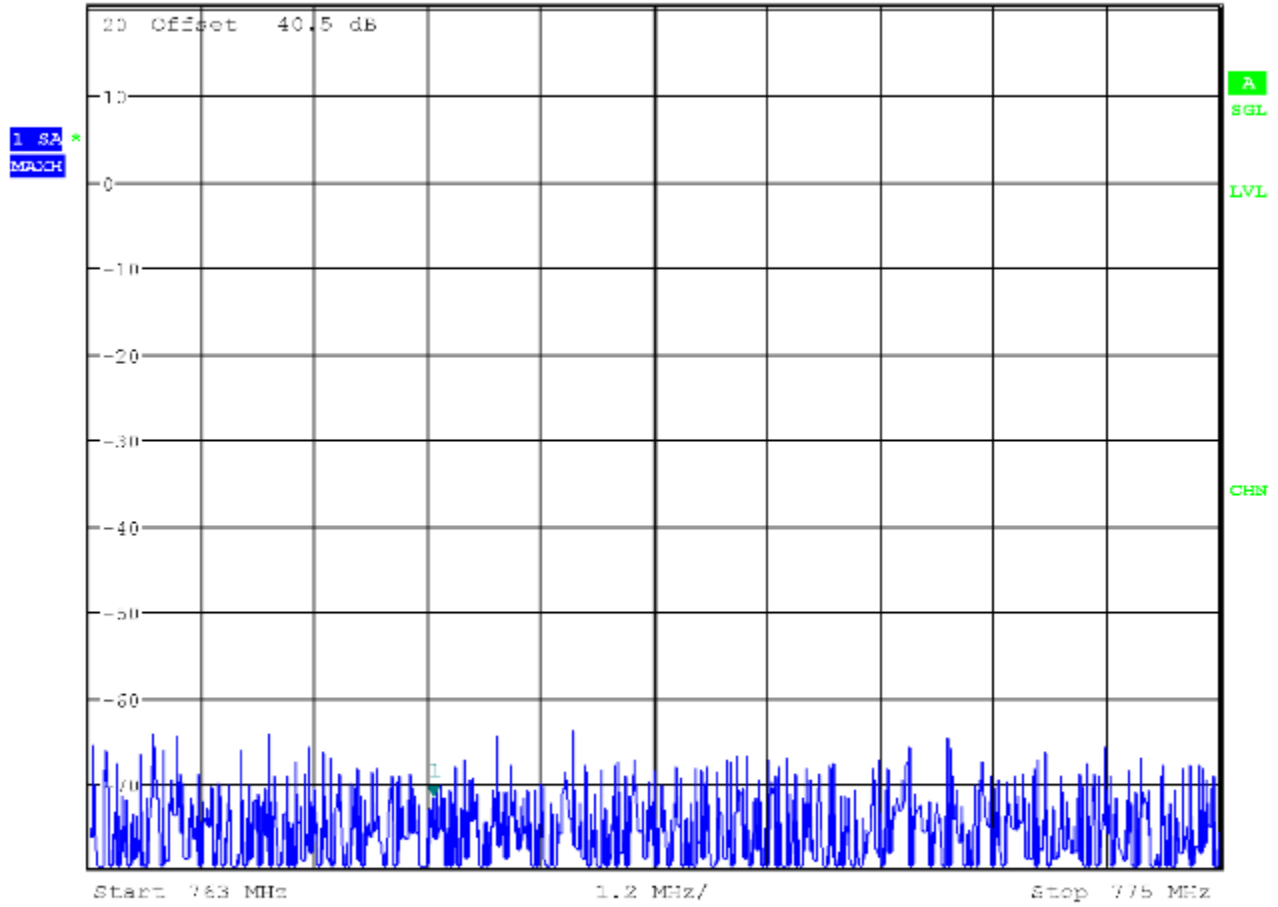

Date: 28.JUN.2012 14:38:02

Conducted Emissions LTE 3.0 MHz Channel Bandwidth Spectrum 700 MHz Path 1
Start 793 MHz Stop 805 MHz RBW 6.0kHz VBW 20 kHz



* RBW 6.0 kHz Marker 1 [T1]
* VBW 20 kHz -62.57 dBm
Ref 20.0 dBm Att 9 dB SWT 28 s 800.057692308 MHz

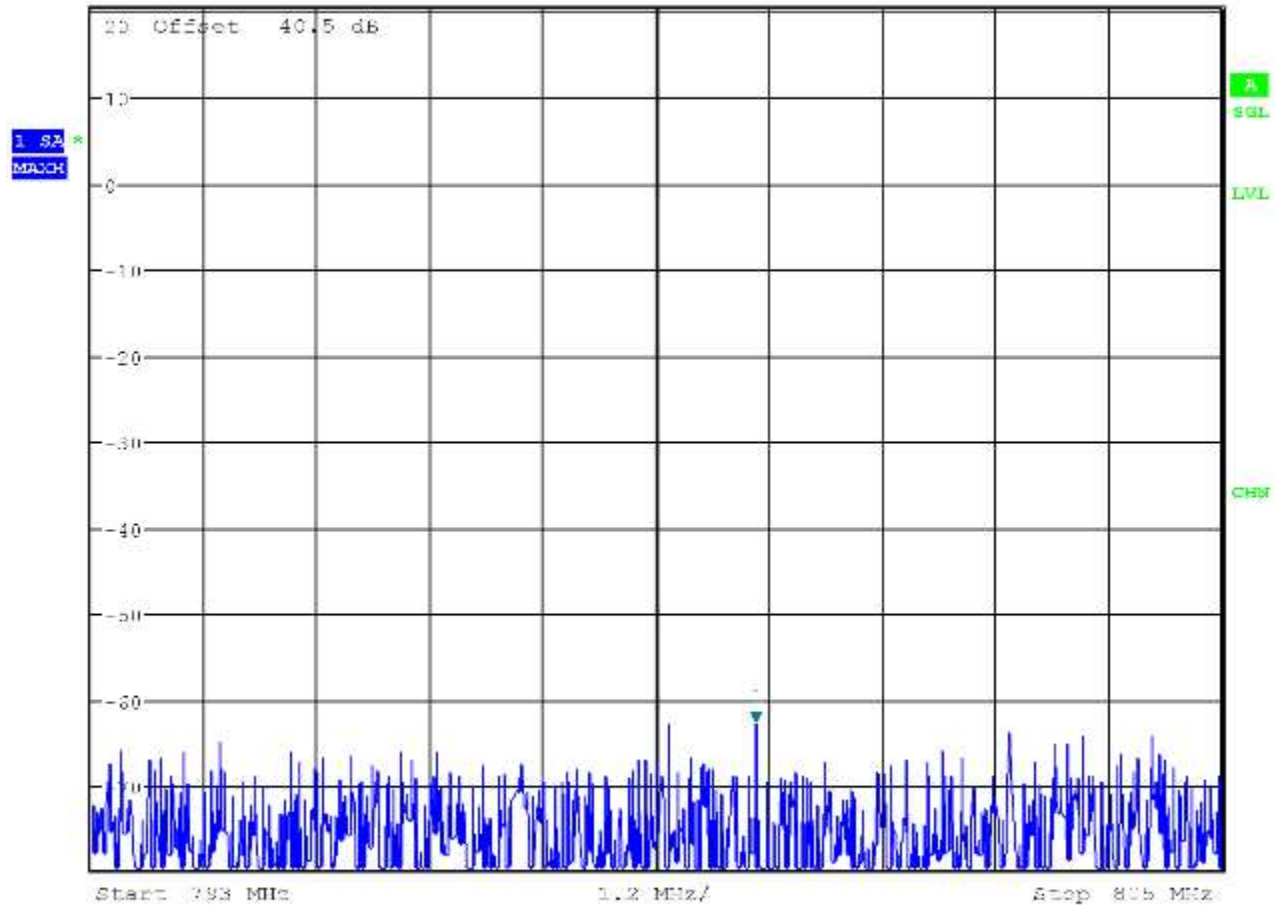

Date: 28.JUN.2012 15:00:53

Conducted Emissions LTE 3.0 MHz Channel Bandwidth Spectrum 700 MHz Path 1
Start 1559 MHz Stop 1610 MHz RBW 6.0kHz VBW 20 kHz



* RBW 6.0 kHz * Marker 1 [T1]
* VBW 20.0 kHz -60.14 dBm
Ref 20.0 dBm Att 9 dB SWT 290.0 s 1.588504808 GHz

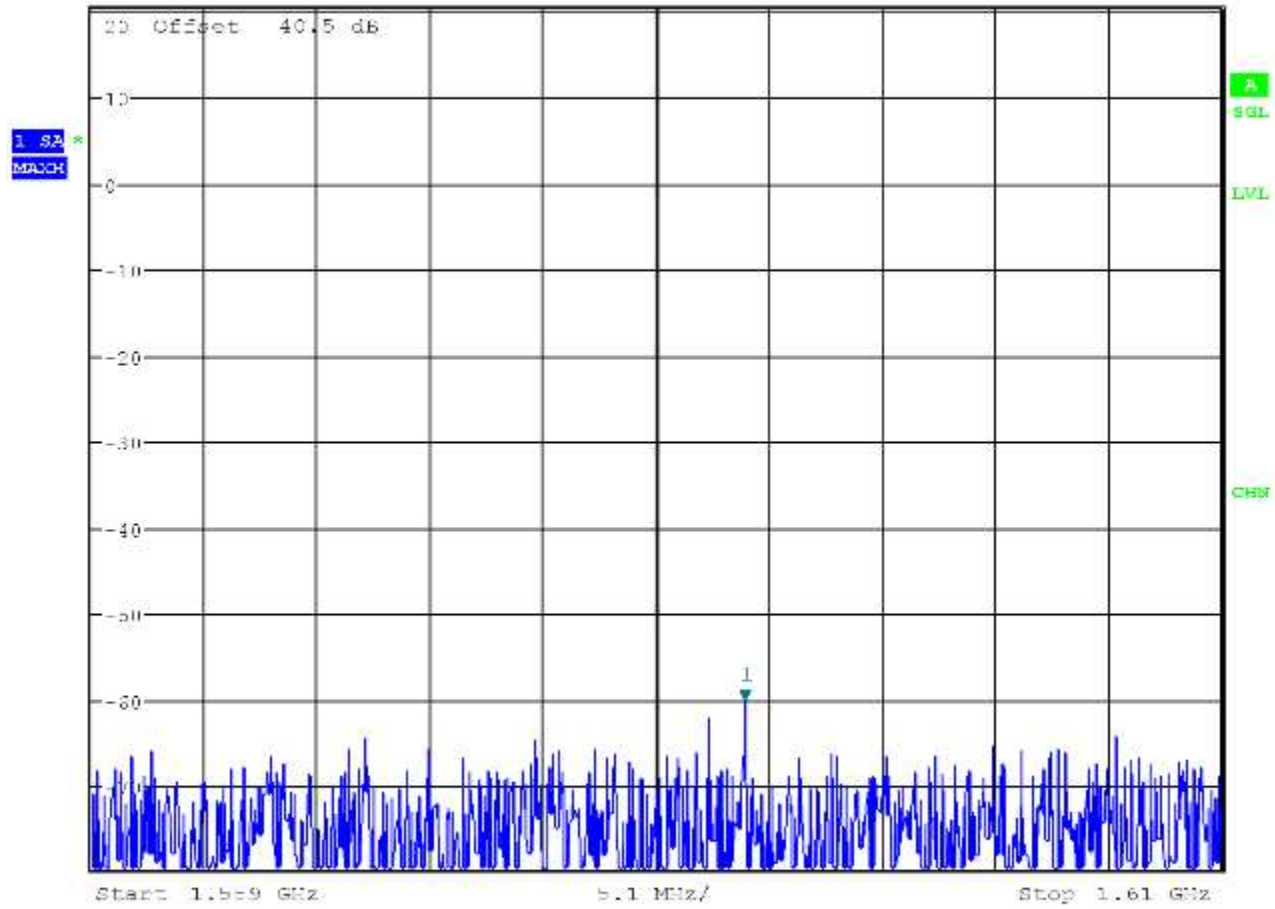

Date: 28.JUN.2012 15:40:13

Conducted Emissions LTE 5.0 MHz Channel Bandwidth Spectrum 700 MHz Path 1
 Start 763 MHz Stop 775 MHz RBW 6.0kHz VBW 20 kHz



* RBW 6.0 kHz Marker 1 [T1] -62.84 dBm
 * VBW 20.0 kHz
 Ref 20.0 dBm Att 9 dB SWT 28 s 767.557692308 MHz

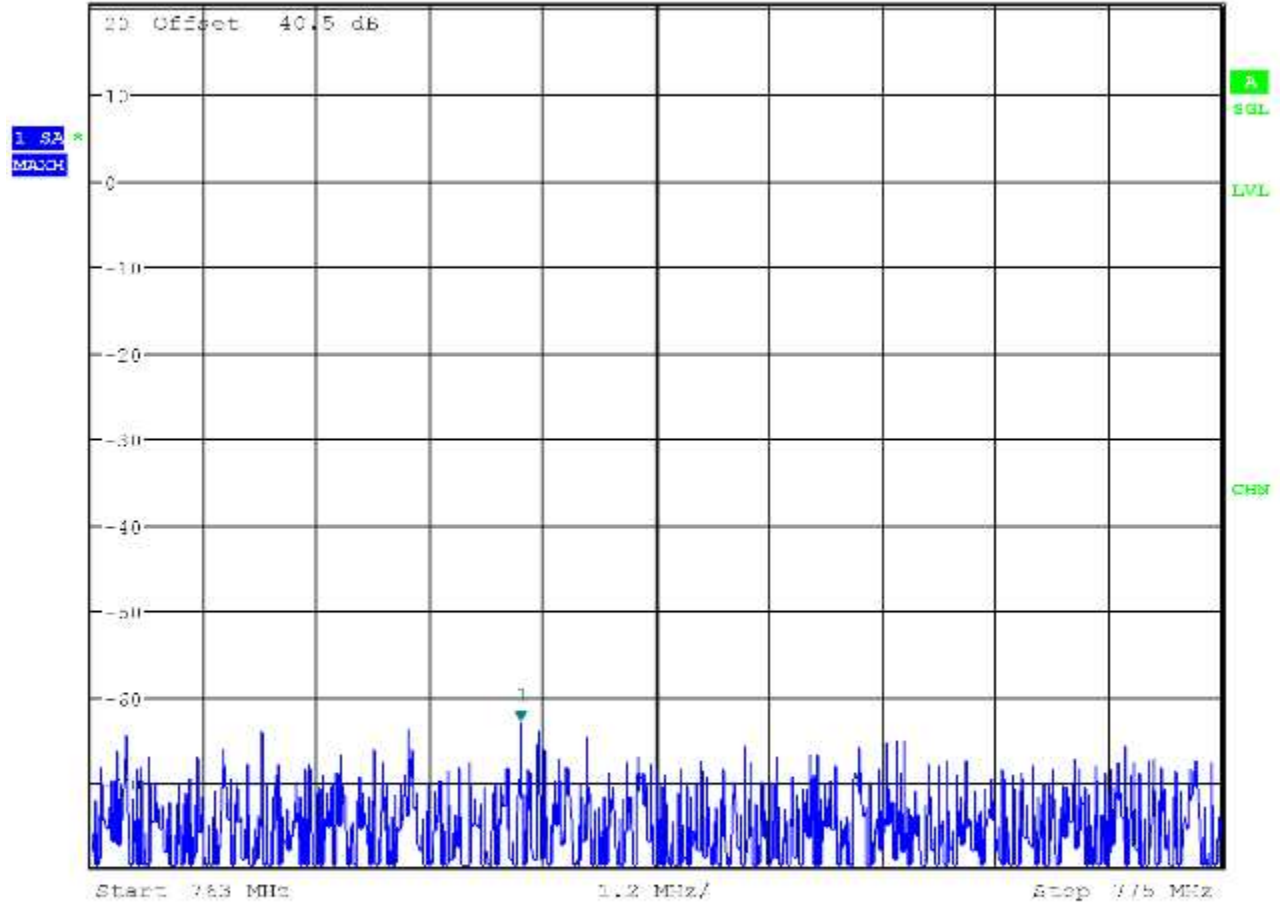

Date: 28.JUN.2012 14:42:03

Conducted Emissions LTE 5.0 MHz Channel Bandwidth Spectrum 700 MHz Path 1
Start 793 MHz Stop 805 MHz RBW 6.0kHz VBW 20 kHz



* RBW 6.0 kHz Marker 1 [T1]
* VBW 20.0 kHz -63.46 dBm

Ref 20.0 dBm Att 9 dB SWT 88 s 804.50000000 MHz

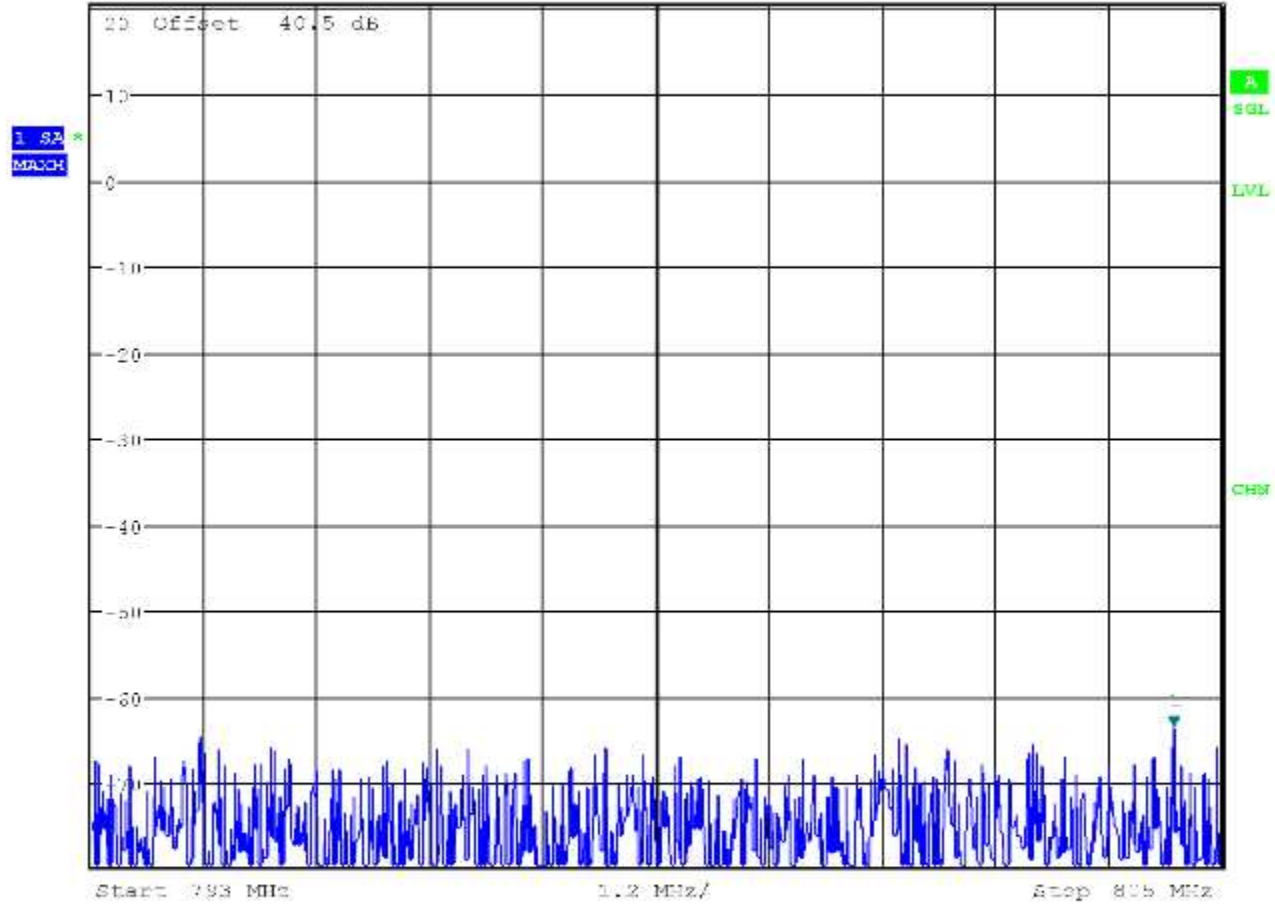

Date: 28.JUN.2012 15:07:46

Conducted Emissions LTE 5.0 MHz Channel Bandwidth Spectrum 700 MHz Path 1
Start 1559 MHz Stop 1610 MHz RBW 6.0kHz VBW 20 kHz



* RBW 6.0 kHz Marker 1 [T1]
* VBW 20.0 kHz -63.31 dBm
SWT 290.0 s 1.586661538 GHz

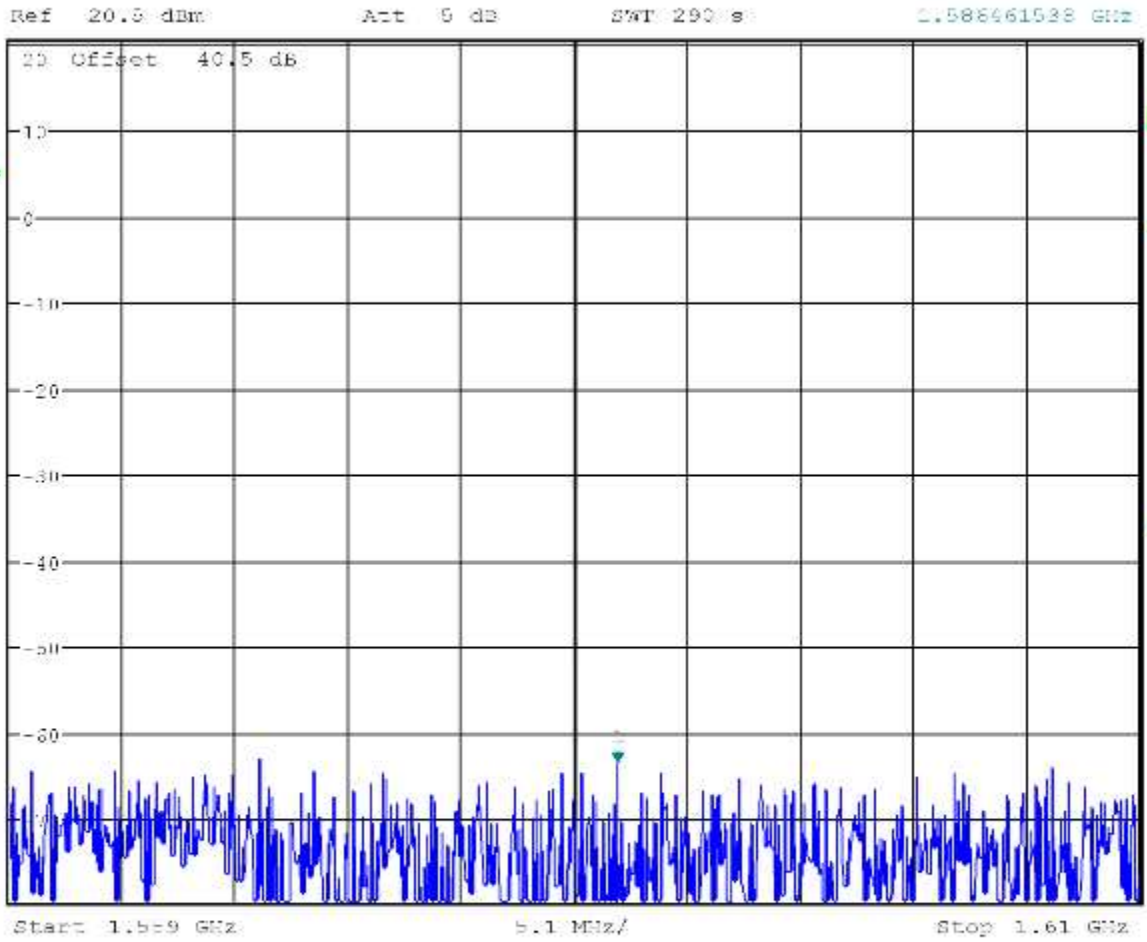

Date: 28.JUN.2012 15:15:12

Conducted Emissions LTE 10.0 MHz Channel Bandwidth Spectrum 700 MHz Path 1
Start 763 MHz Stop 775 MHz RBW 6.0kHz VBW 20 kHz



*RBW 6 kHz Marker 1 [T1]
*VBW 20 kHz -62.31 dBm
Ref 20.0 dBm Att 9 dB SWT 88 s 770.519230769 MHz

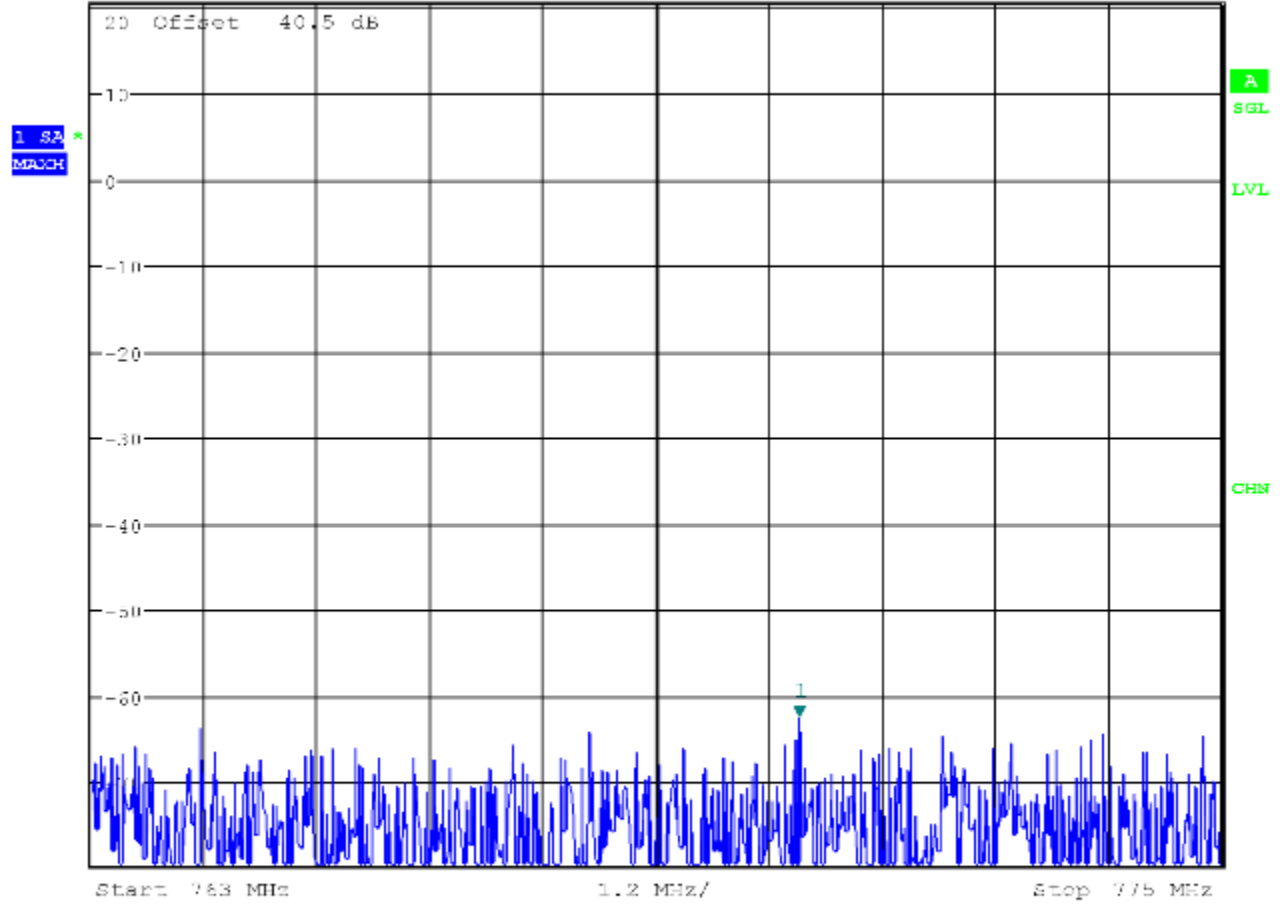

Date: 28.JUN.2012 14:45:41

Conducted Emissions LTE 10.0 MHz Channel Bandwidth Spectrum 700 MHz Path 1
Start 793 MHz Stop 805 MHz RBW 6.0kHz VBW 20 kHz



*RBW 6 kHz Marker 1 [T1]
*VBW 20 kHz -63.81 dBm
803.038461538 MHz

Ref 20.0 dBm Att 9 dB SWT 88 s

1 SA*
MACH

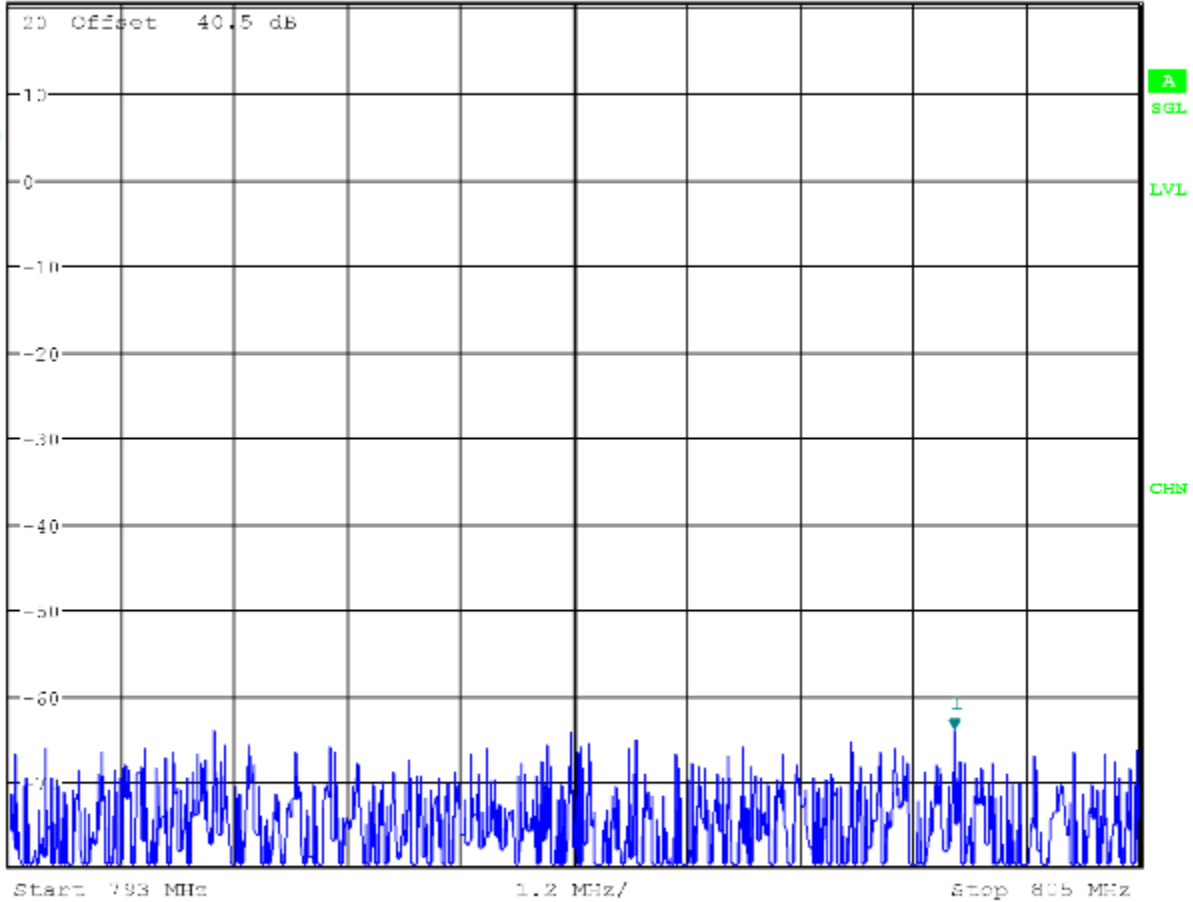

Date: 28.JUN.2012 14:50:54

Conducted Emissions LTE 10.0 MHz Channel Bandwidth Spectrum 700 MHz Path 1
Start 1559 MHz Stop 1610 MHz RBW 6.0kHz VBW 20 kHz



* RBW 6.0 kHz Marker 1 [T1]
* VBW 20.0 kHz -63.03 dBm
Ref 20.0 dBm Att 9 dB SWT 290.0 s 1.607221154 GHz

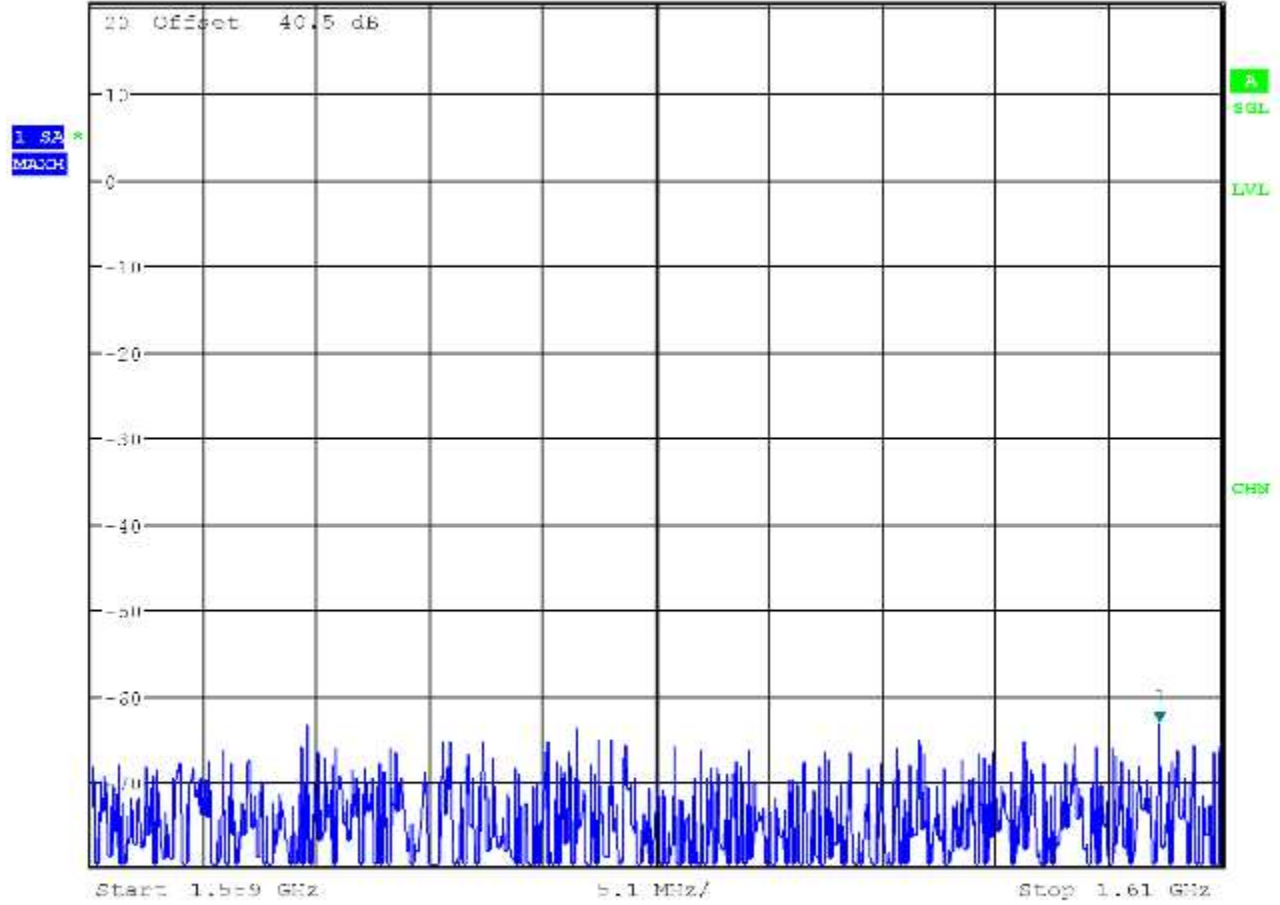

Date: 28.JUN.2012 15:56:54

Conducted Emissions WCDMA Spectrum AWS Path 1
Center: 2132.5 MHz Span: 10 MHz RBW/VBW: 100 kHz
ATTEN 10dB MKR -21.83dBm
RL 40.5dBm 10dB/ 2.12998GHz

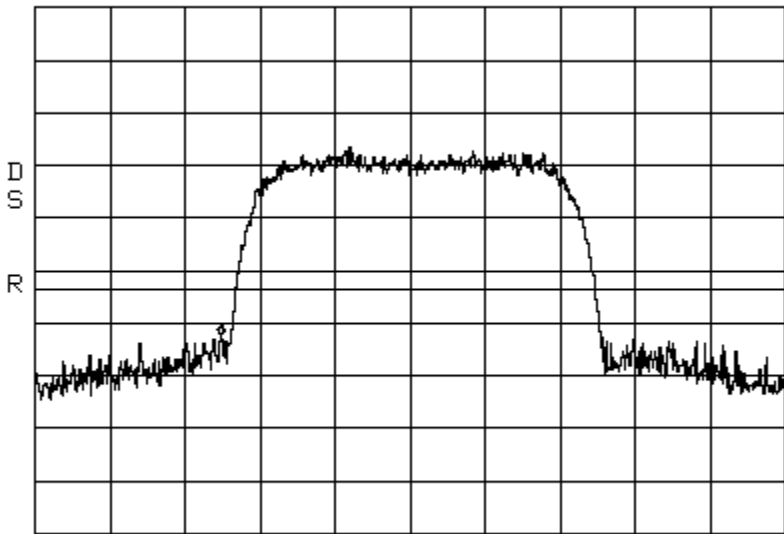

CENTER 2.13250GHz SPAN 10.00MHz
*RBW 100kHz *VBW 100kHz SWP 50ms

Conducted Emissions WCDMA Spectrum AWS Path 1
Span: 30 MHz to 1 GHz RBW/VBW: 300 kHz

ATTEN 10dB MKR -29.50dBm
RL 40.5dBm 10dB/ 1.00000GHz

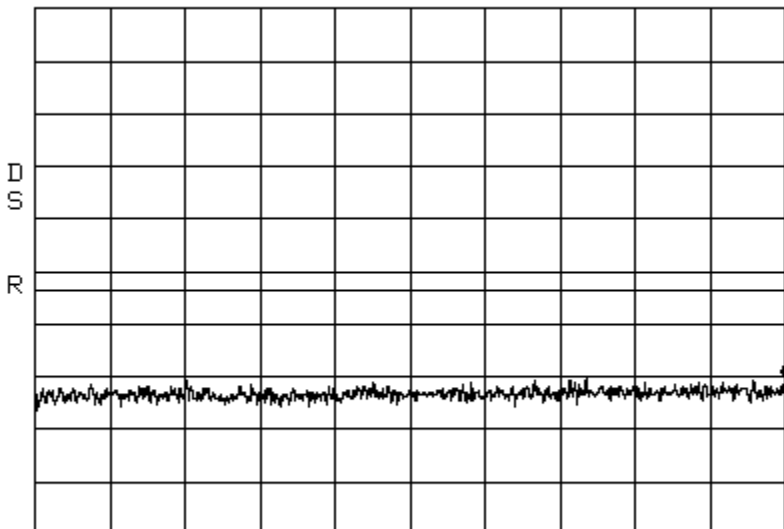

START 30.0MHz STOP 1.00000GHz
*RBW 300kHz *VBW 300kHz SWP 50ms

Conducted Emissions WCDMA Spectrum AWS Path 1
 Span: 1 GHz to 22 GHz RBW/VBW: 1 MHz
 ATTN 10dB MKR -20.67dBm
 RL 40.5dBm 10dB/ 21.51GHz

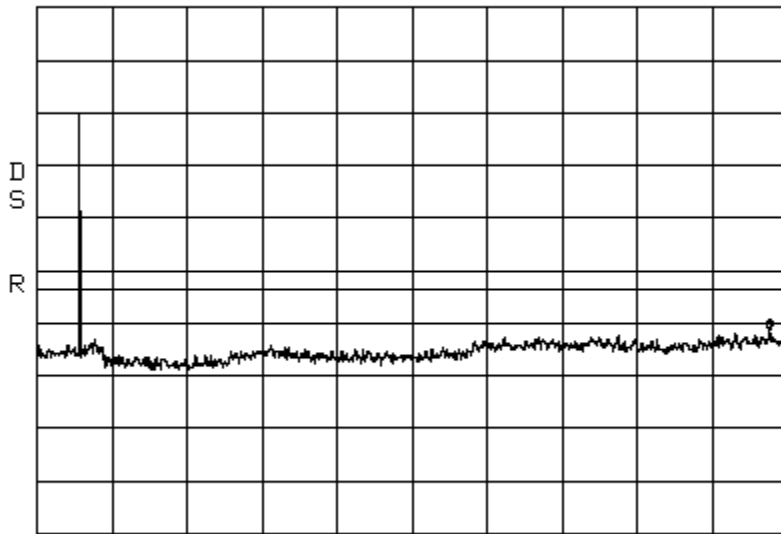

START 1.00GHz STOP 22.00GHz
 *RBW 1.0MHz *VBW 1.0MHz SWP 420ms

Conducted Emissions LTE 3 MHz Channel Bandwidth AWS Path 1
 Center: 2132.5 MHz Span: 5 MHz RBW/VBW: 100 kHz
 ATTN 10dB MKR -19.17dBm
 RL 40.5dBm 10dB/ 2.130250GHz

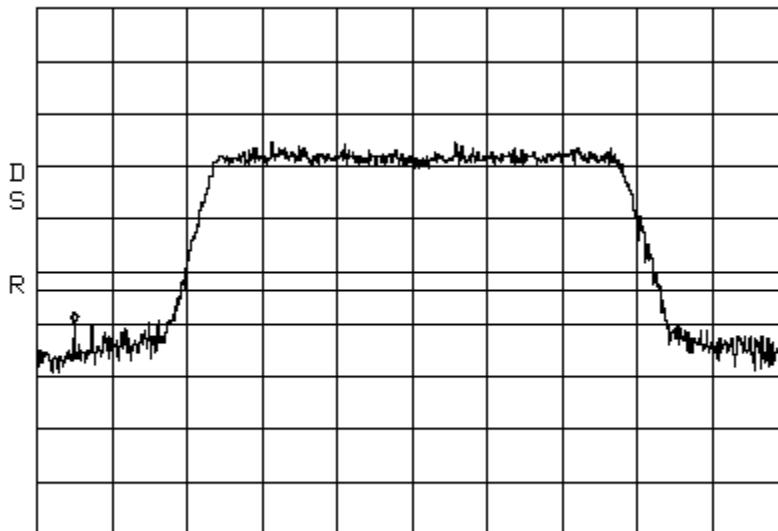

CENTER 2.132500GHz SPAN 5.000MHz
 *RBW 100kHz *VBW 100kHz SWP 50ms

Conducted Emissions

LTE 3 MHz Channel Bandwidth

AWS Path 1

Span: 30 MHz to 1 GHz

RBW/VBW: 300 kHz

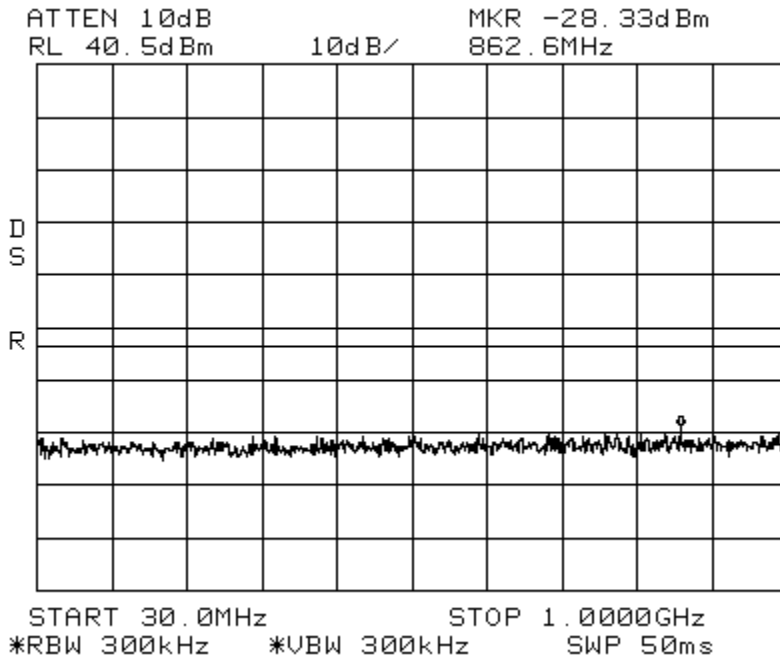

Conducted Emissions

LTE 3 MHz Channel Bandwidth

AWS Path 1

Span: 1 GHz to 22 GHz

RBW/VBW: 1 MHz

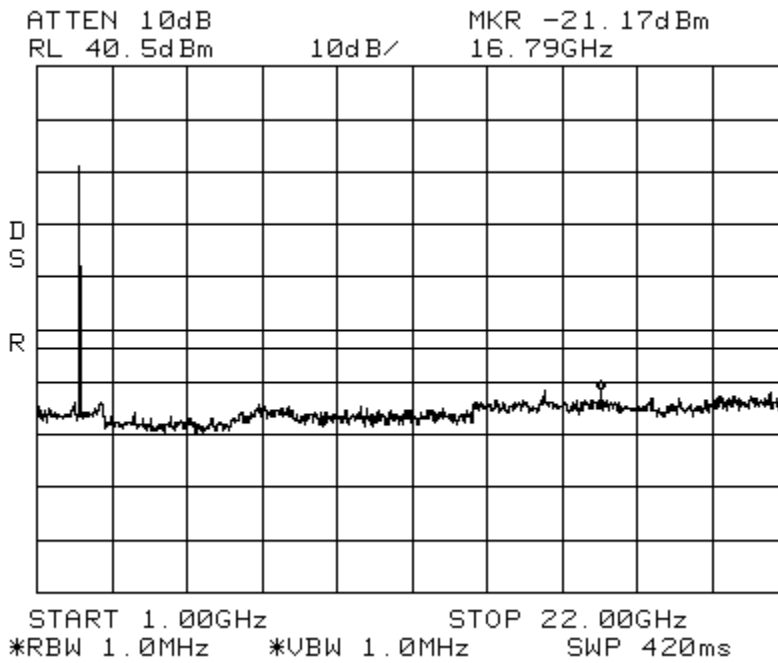

Conducted Emissions LTE 5 MHz Channel Bandwidth AWS Path 1
Center: 2132.5 MHz Span: 10 MHz RBW/VBW: 100 kHz
ATTEN 10dB MKR -21.83dBm
RL 40.5dBm 10dB/ 2.12990GHz

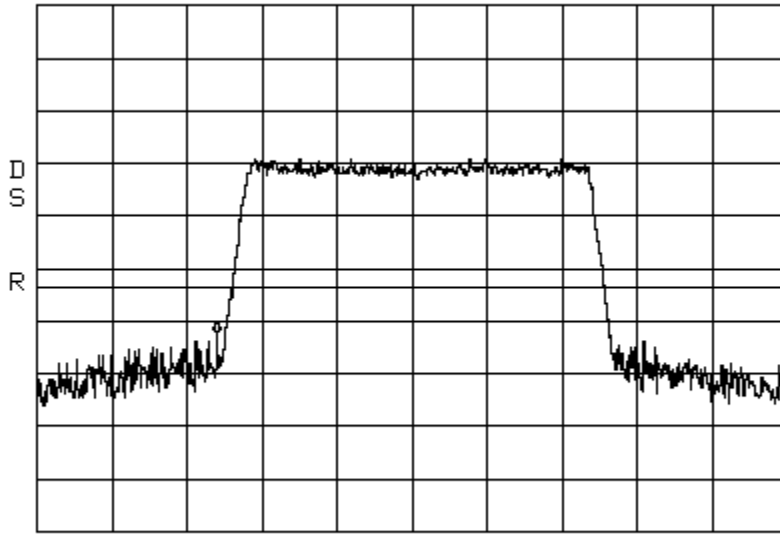

CENTER 2.13250GHz SPAN 10.00MHz
*RBW 100kHz *VBW 100kHz SWP 50ms

Conducted Emissions LTE 5 MHz Channel Bandwidth AWS Path 1
Span: 30 MHz to 1 GHz RBW/VBW: 300 kHz

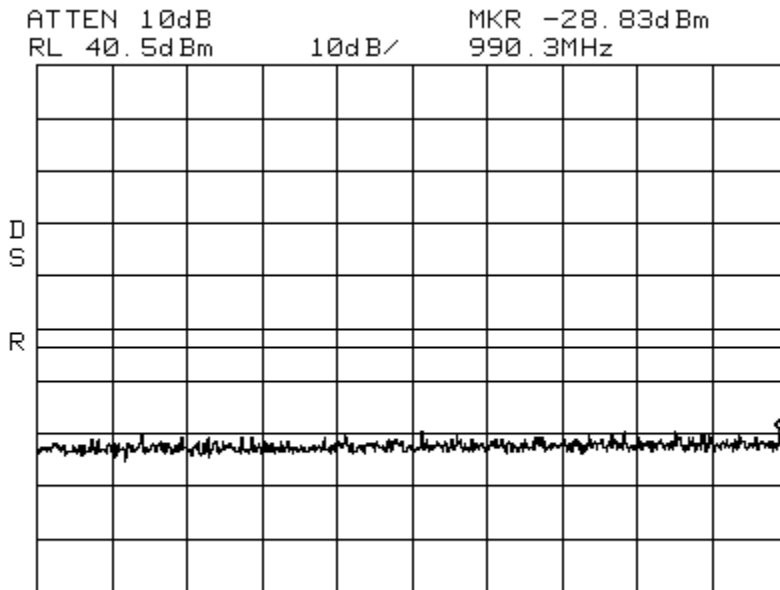

START 30.0MHz STOP 1.0000GHz
*RBW 300kHz *VBW 300kHz SWP 50ms

Conducted Emissions

LTE 5 MHz Channel Bandwidth

AWS Path 1

Span: 1 GHz to 22GHz

RBW/VBW: 1 MHz

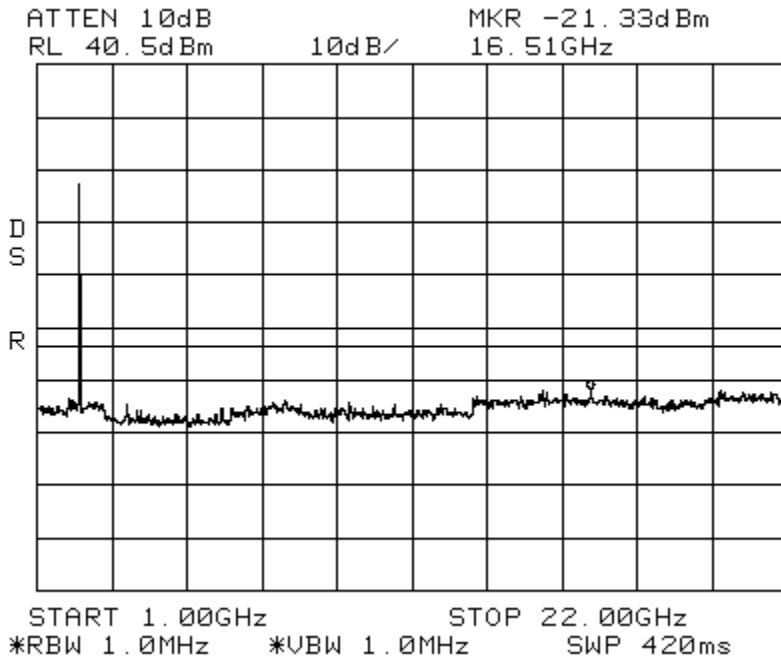

Conducted Emissions

LTE 10 MHz Channel Bandwidth

AWS Path 1

Center: 2132.5 MHz

Span: 20MHz

RBW/VBW: 100 kHz

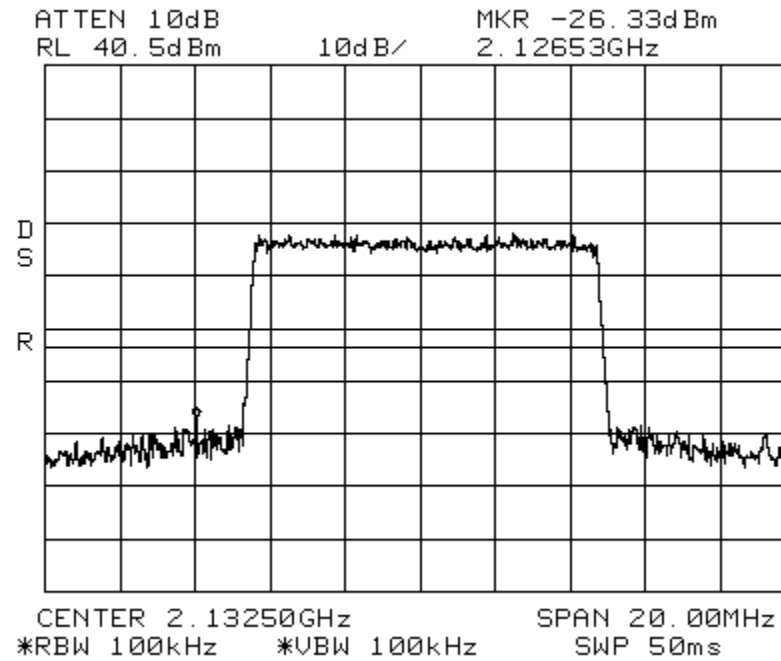

Conducted Emissions

LTE 10 MHz Channel Bandwidth

AWS Path 1

Span: 30 MHz to 1 GHz

RBW/VBW: 300 kHz

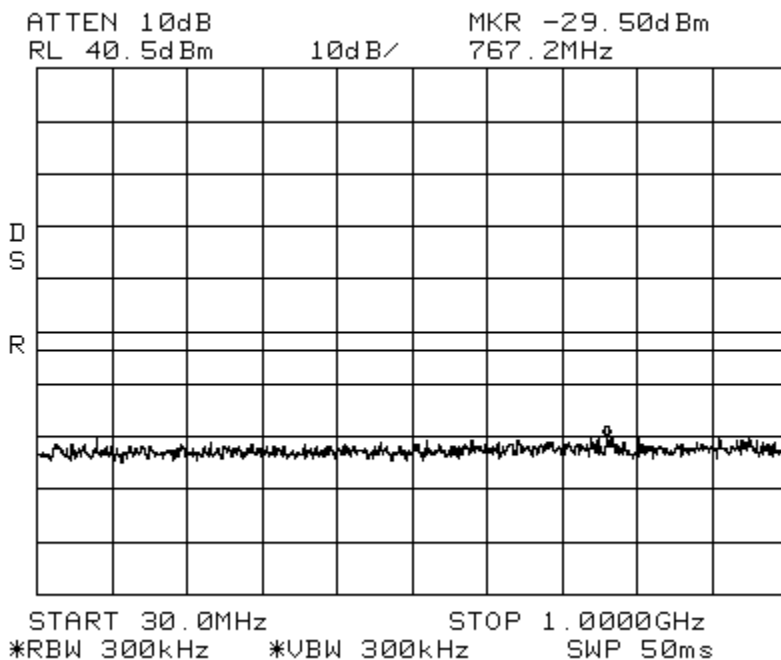

Conducted Emissions

LTE 10 MHz Channel Bandwidth

AWS Path 1

Span: 1 GHz to 22 GHz

RBW/VBW: 1 MHz

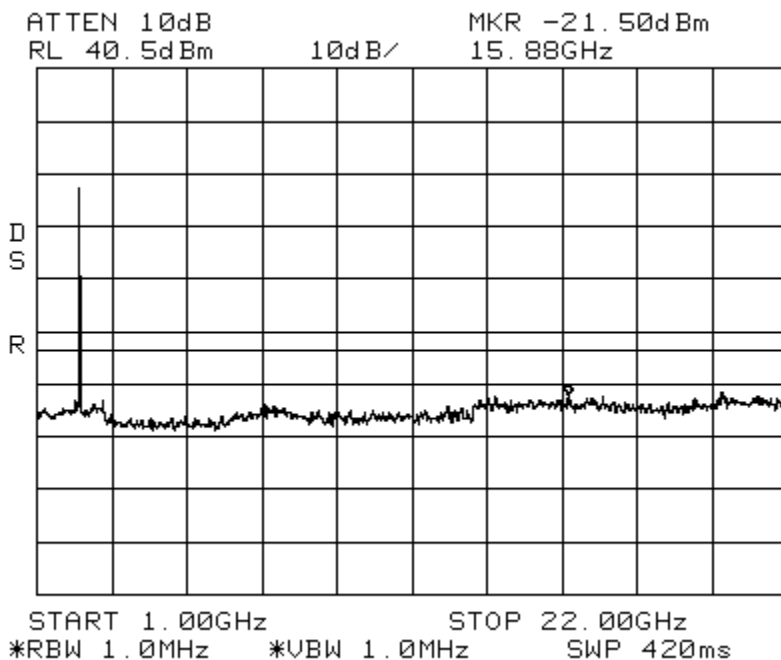

Conducted Emissions LTE 15 MHz Channel Bandwidth AWS Path 1
 Center: 2132.5 MHz Span: 30 MHz RBW/VBW: 100 kHz
 ATTN 10dB MKR -28.83dBm
 RL 40.5dBm 10dB/ 2.12385GHz

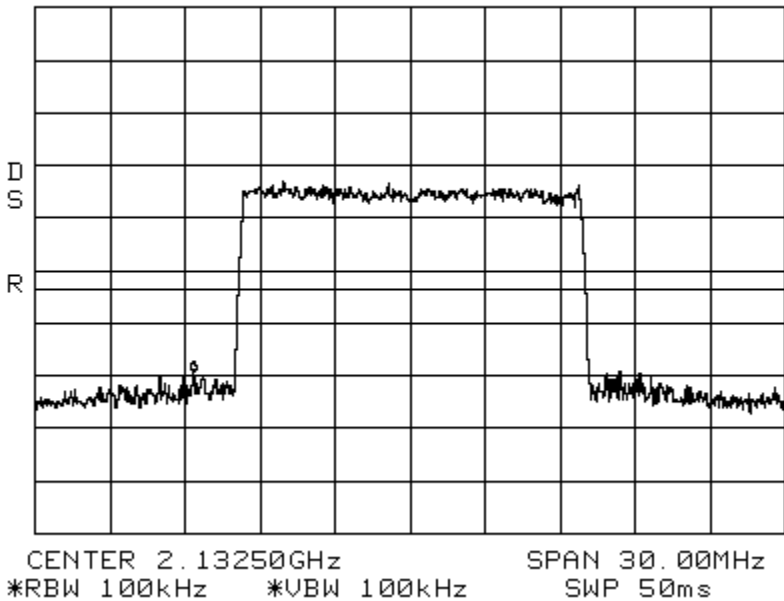

Conducted Emissions LTE 15 MHz Channel Bandwidth AWS Path 1
 Span: 30 MHz to 1 GHz RBW/VBW: 300 kHz

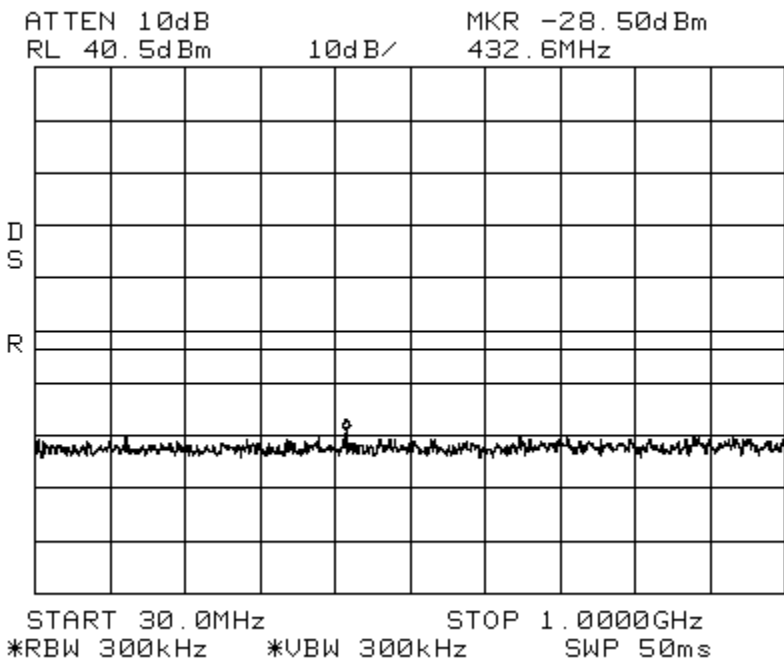

Conducted Emissions

LTE 15 MHz Channel Bandwidth

AWS Path 1

Span: 1 GHz to 22 GHz

RBW/VBW: 1 MHz

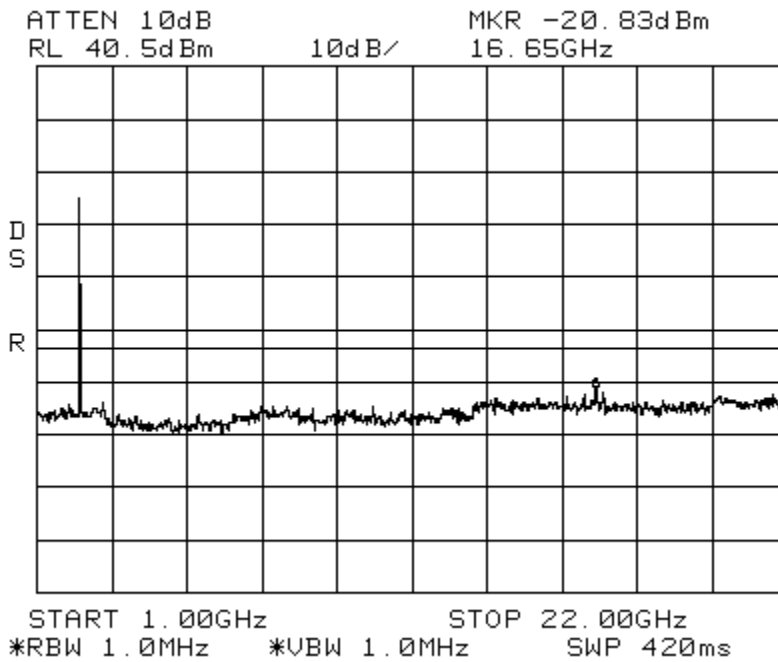

Conducted Emissions

LTE 20 MHz Channel Bandwidth

AWS Path 1

Center: 2132.5 MHz

Span: 50MHz

RBW/VBW: 100 kHz

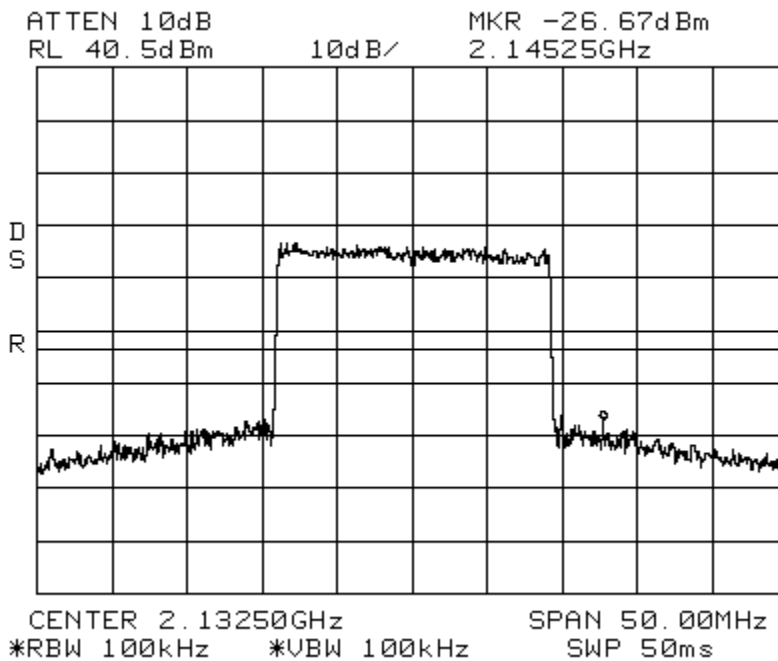

Conducted Emissions LTE 20 MHz Channel Bandwidth AWS Path 1
Span: 30 MHz to 1 GHz RBW/VBW: 300 kHz

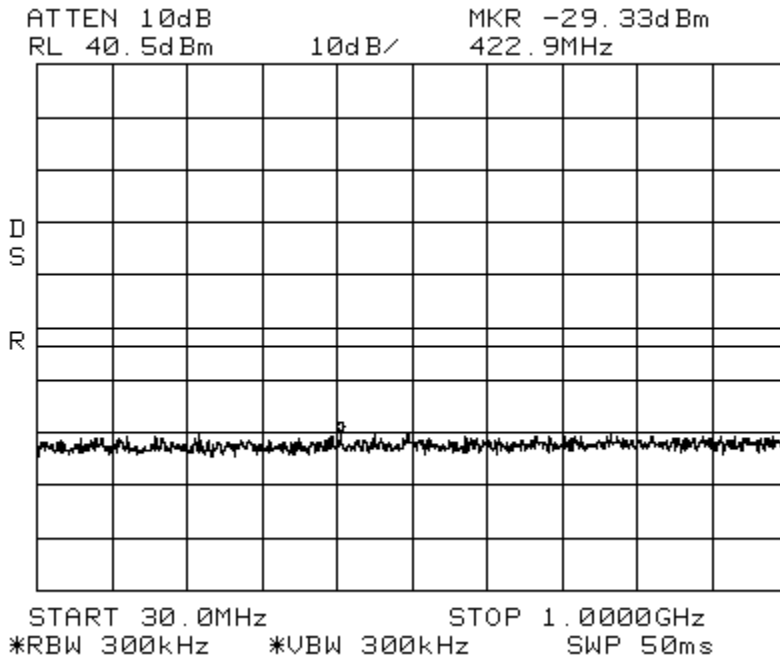

Conducted Emissions LTE 20 MHz Channel Bandwidth AWS Path 1
Span: 1 GHz to 22 GHz RBW/VBW: 1 MHz

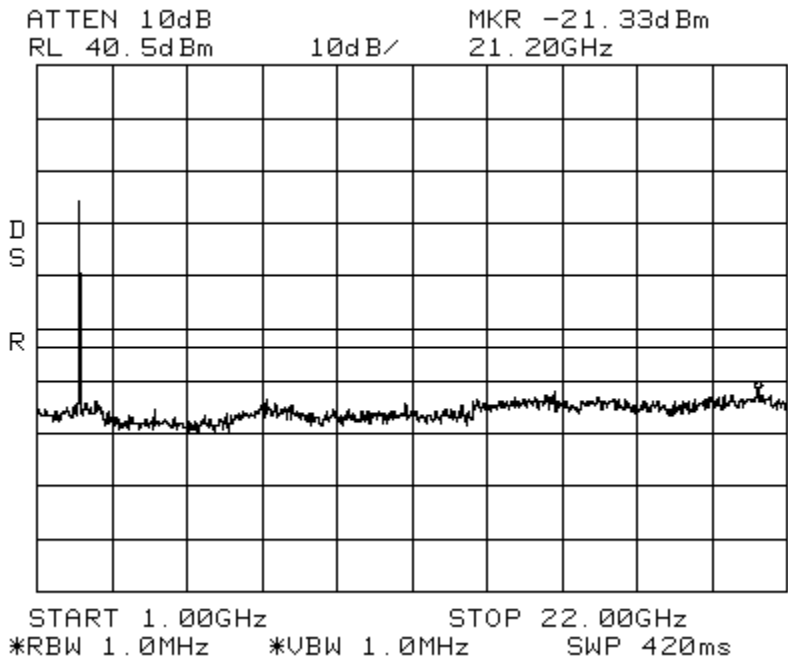

Band_Edge

LTE 1.4 MHz Channel Bandwidth
ABC MHz Path 1

Spectrum 700 Lower

Center: 728.7MHz

Span: 10 MHz

RBW: 3 kHz

VBW: 10 kHz

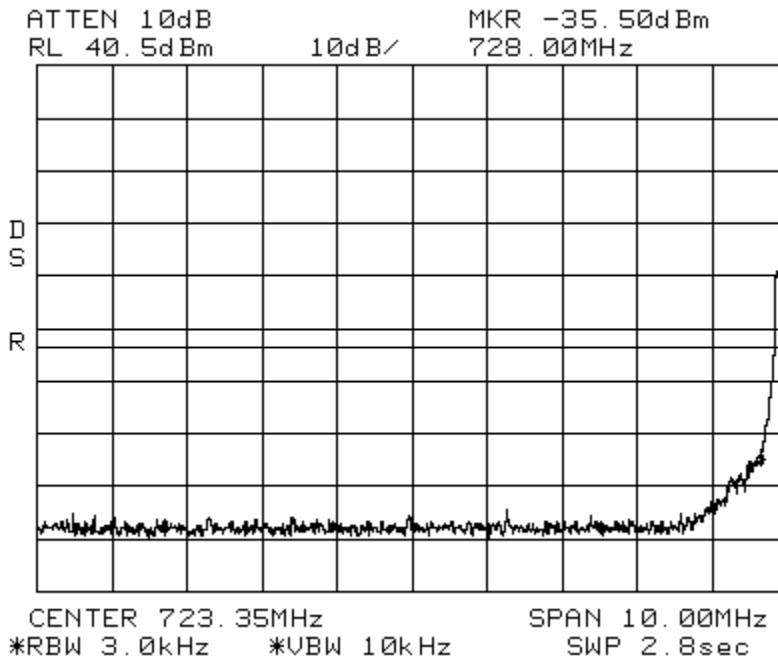

Band_Edge

LTE 1.4 MHz Channel Bandwidth
ABC MHz Path 1

Spectrum 700 Lower

Center: 745.3 MHz

Span: 10 MHz

RBW: 3 kHz

VBW: 10 kHz

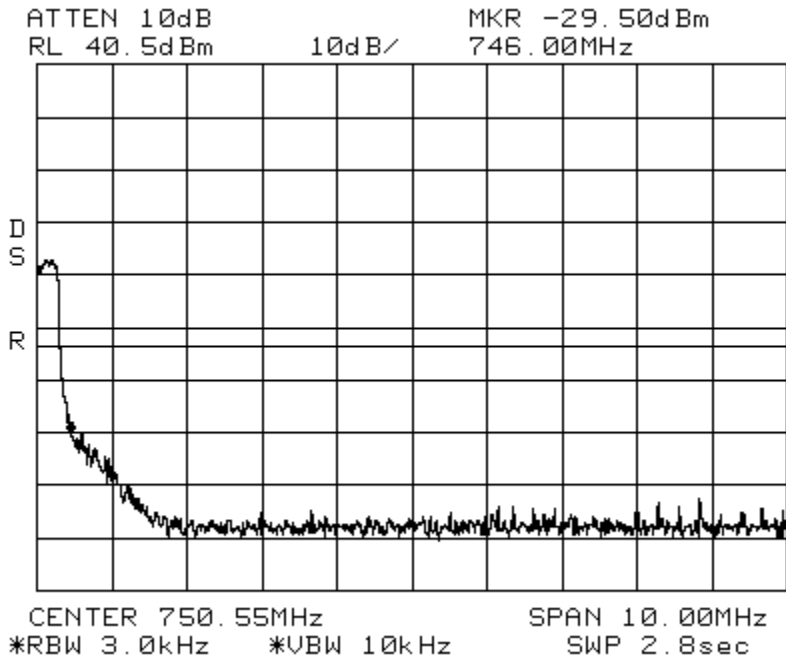

Band_Edge

LTE 3 MHz Channel Bandwidth

Spectrum 700 MHz

Lower ABC Path 1

Center: 729.5 MHz Span: 10 MHz RBW: 30 kHz VBW: 100 kHz

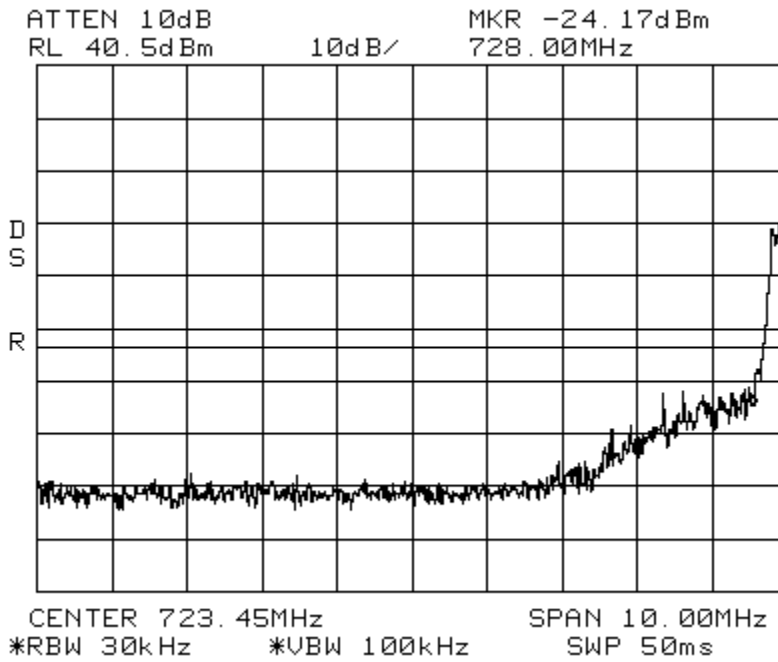

Band_Edge

LTE 3MHz Channel Bandwidth

Spectrum 700 MHz

Lower ABC Path 1

Center: 744.5 MHz Span: 10 MHz RBW: 30 kHz VBW: 100 kHz

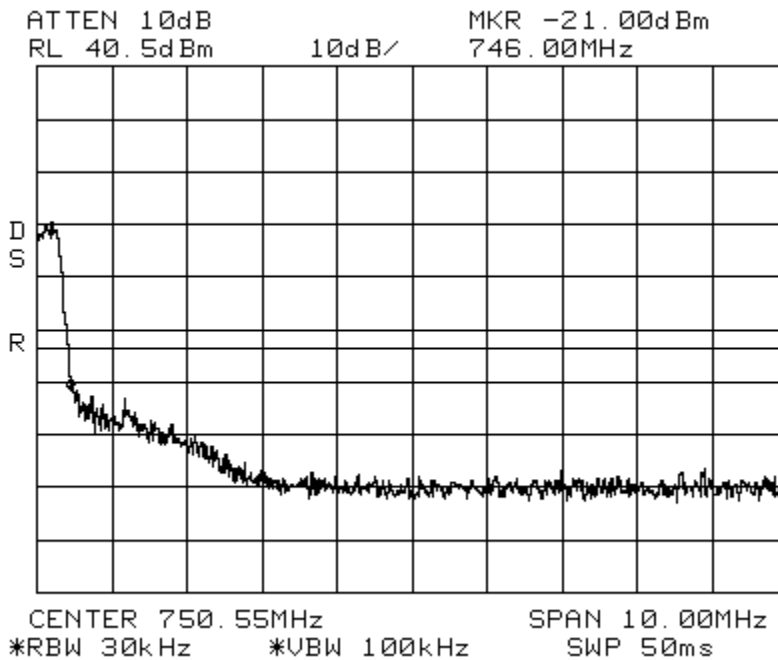

Band_Edge

LTE 5 MHz Channel Bandwidth

Spectrum 700 MHz

Lower ABC Path 1

Center: 730.5 MHz Span: 10 MHz RBW: 30 kHz VBW: 100 kHz

ATTEN 10dB MKR -33.33dBm
RL 40.5dBm 10dB/ 728.00MHz

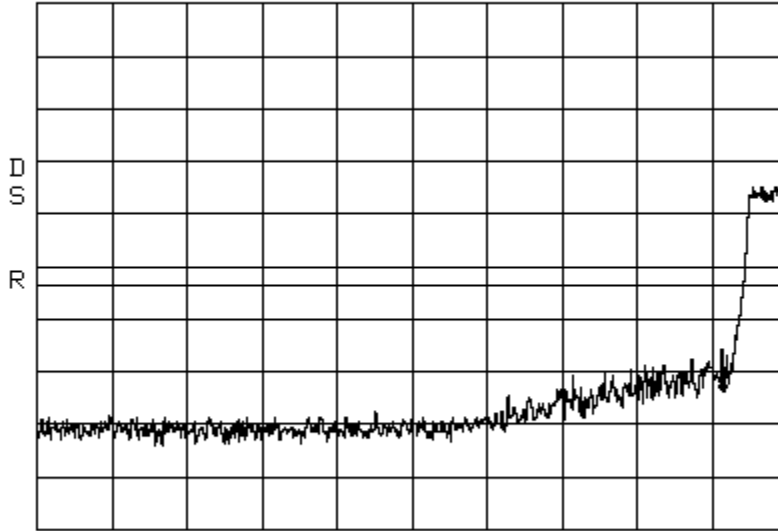

CENTER 723.85MHz SPAN 10.00MHz
*RBW 30kHz *VBW 100kHz SWP 50ms

Band_Edge

LTE 5 MHz Channel Bandwidth

Spectrum 700 MHz

Lower ABC Path 1

Center: 743.5 MHz Span: 10 MHz RBW: 30 kHz VBW: 100 kHz

ATTEN 10dB MKR -28.50dBm
RL 40.5dBm 10dB/ 746.00MHz

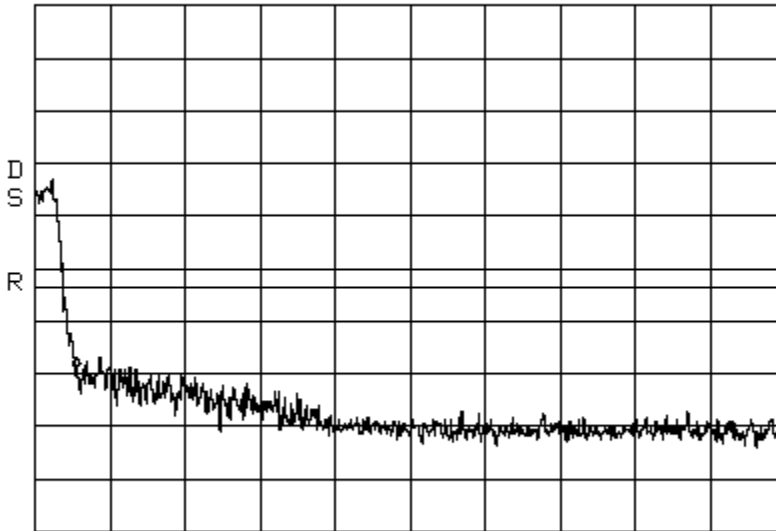

CENTER 750.45MHz SPAN 10.00MHz
*RBW 30kHz *VBW 100kHz SWP 50ms

Band_Edge

LTE 10 MHz Channel Bandwidth

Spectrum 700 MHz

Lower ABC Path 1

Center: 733 MHz

Span: 20 MHz

RBW: 100 kHz

VBW: 100 kHz

ATTEN 10dB

MKR -22.50dBm

RL 40.5dBm

10dB/

728.00MHz

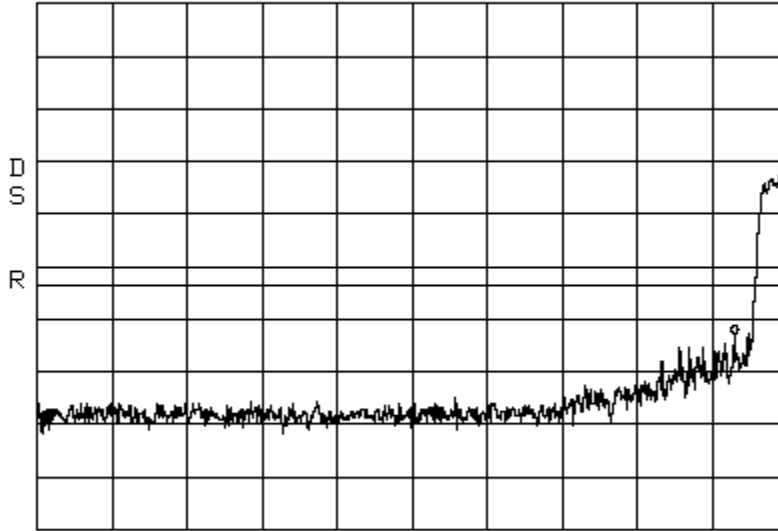

CENTER 719.40MHz SPAN 20.00MHz
*RBW 100kHz *VBW 100kHz SWP 50ms

Band_Edge

LTE 10 MHz Channel Bandwidth

Spectrum 700 MHz

Lower ABC Path 1

Center: 741 MHz

Span: 20 MHz

RBW: 100 kHz

VBW: 100 kHz

ATTEN 10dB

MKR -27.50dBm

RL 40.5dBm

10dB/

746.00MHz

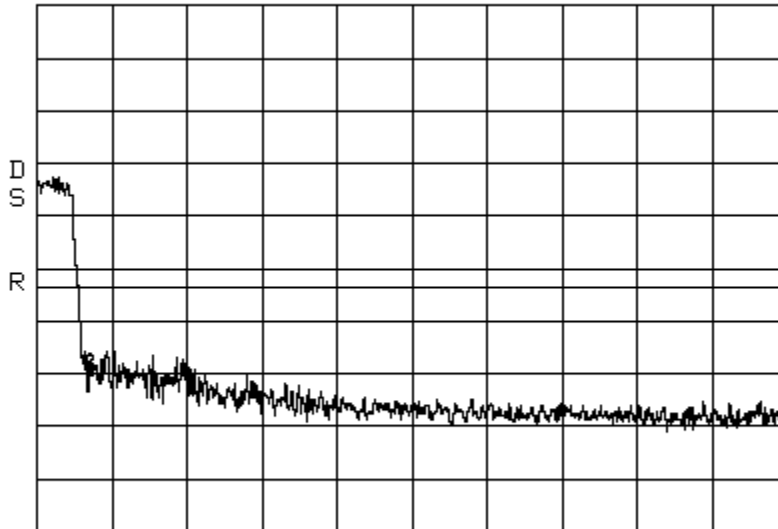

CENTER 754.60MHz SPAN 20.00MHz
*RBW 100kHz *VBW 100kHz SWP 50ms

Band_Edge

LTE 1.4 MHz Channel Bandwidth
Upper C Path 1

Spectrum 700 MHz

Center: 746.7MHz

Span: 5 MHz

RBW: 3 kHz

VBW: 10 kHz

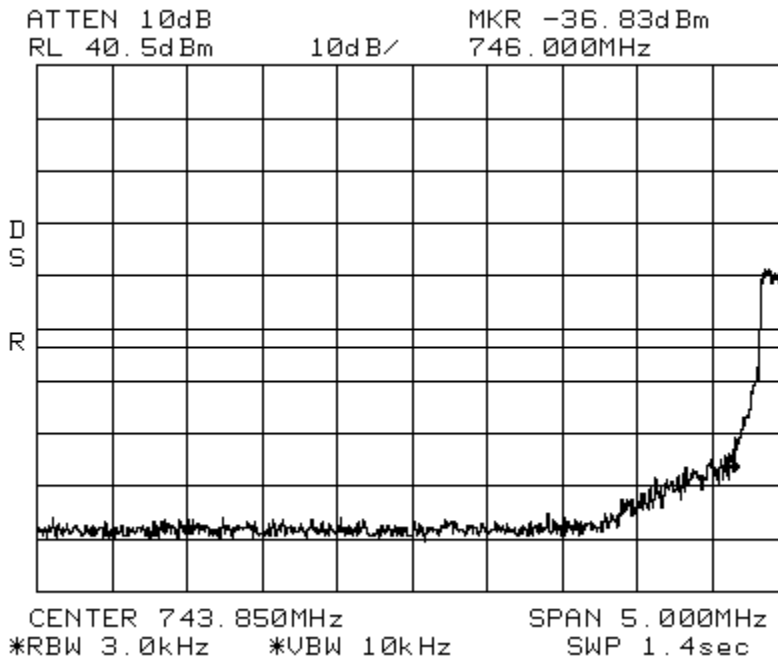

Band_Edge

LTE 1.4 MHz Channel Bandwidth
Upper C Path 1

Spectrum 700 MHz

Center: 756.3 MHz

Span: 5 MHz

RBW: 3 kHz

VBW: 10 kHz

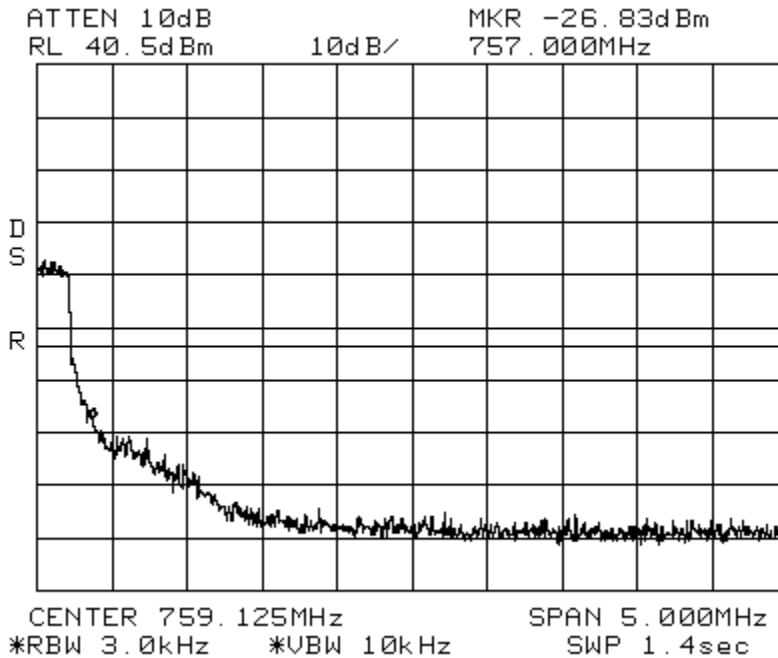

Band_Edge

LTE 3 MHz Channel Bandwidth

Spectrum 700 MHz

Upper C Path 1

Center: 747.5 MHz Span: 5 MHz RBW: 30 kHz VBW: 100 kHz

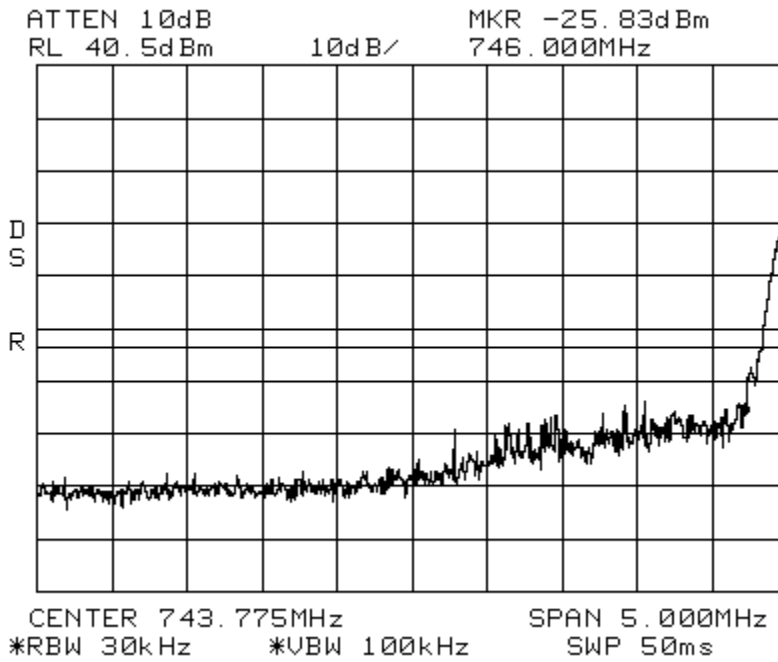

Band_Edge

LTE 3MHz Channel Bandwidth

Spectrum 700 MHz

Upper C Path 1

Center: 755.5 MHz Span: 5 MHz RBW: 30 kHz VBW: 100 kHz

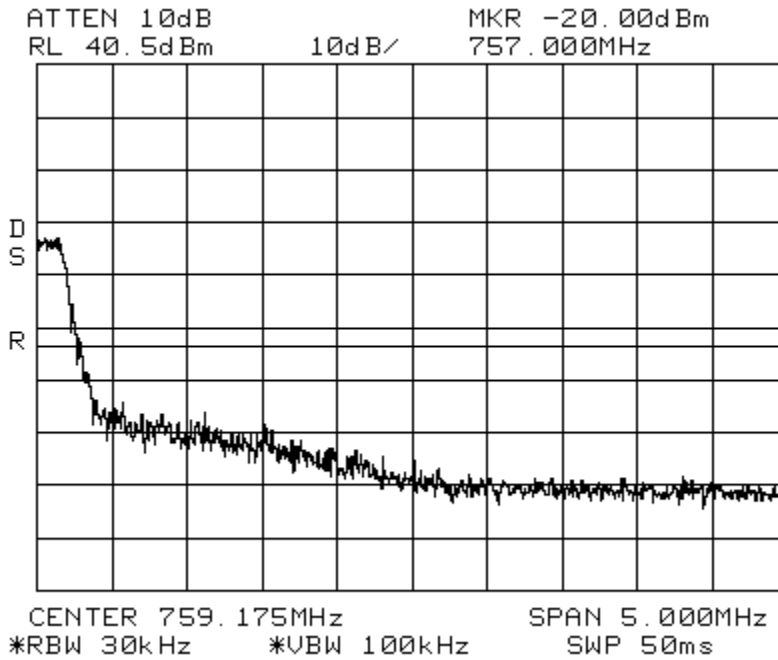

Band_Edge

LTE 5 MHz Channel Bandwidth

Spectrum 700 MHz

Upper C Path 1

Center: 748.5 MHz Span: 10 MHz RBW: 30 kHz VBW: 100 kHz

ATTEN 10dB

MKR -31.50dBm

RL 40.5dBm

10dB/

746.00MHz

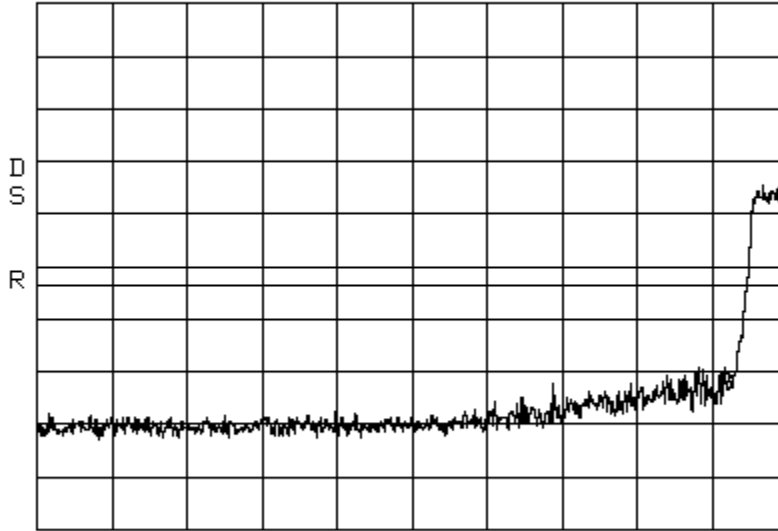

CENTER 741.80MHz SPAN 10.00MHz
*RBW 30kHz *VBW 100kHz SWP 50ms

Band_Edge

LTE 5 MHz Channel Bandwidth

Spectrum 700 MHz

Upper C Path 1

Center: 754.5 MHz Span: 10 MHz RBW: 30 kHz VBW: 100 kHz

ATTEN 10dB

MKR -28.17dBm

RL 40.5dBm

10dB/

757.00MHz

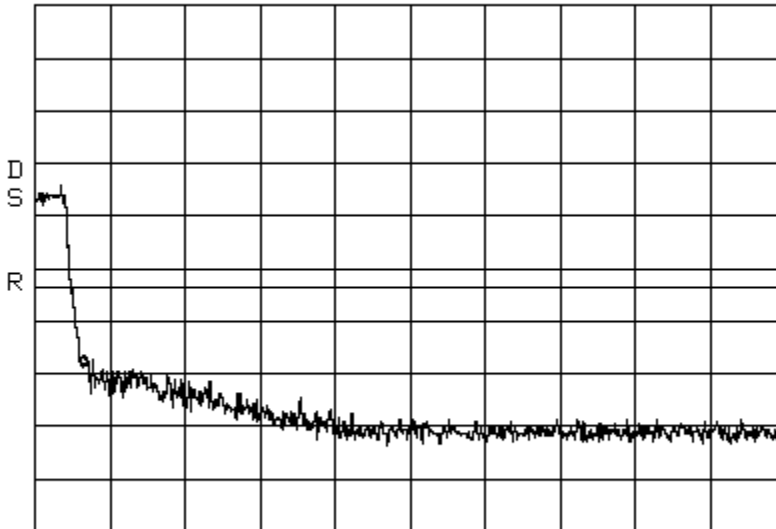

CENTER 761.35MHz SPAN 10.00MHz
*RBW 30kHz *VBW 100kHz SWP 50ms

Band_Edge

LTE 10 MHz Channel Bandwidth

Spectrum 700 MHz

Upper C Path 1

Center: 751 MHz

Span: 15 MHz

RBW: 100 kHz

VBW: 100 kHz

ATTEN 10dB

MKR -27.83dBm

RL 40.5dBm

10dB/

746.00MHz

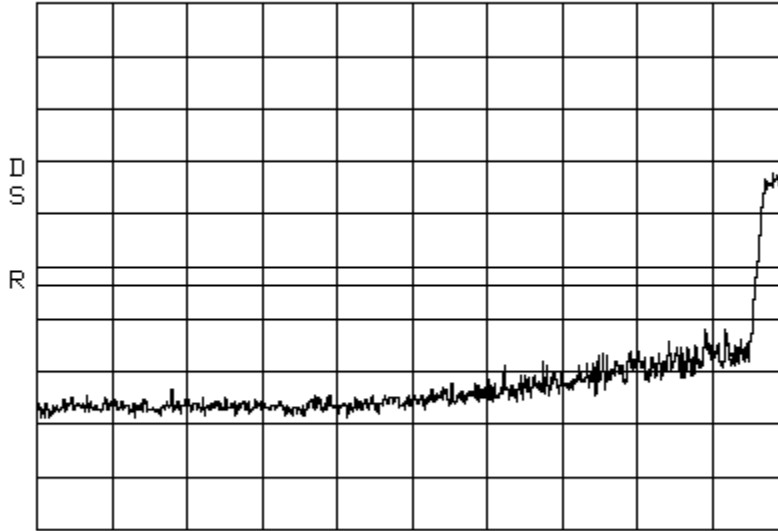

CENTER 739.60MHz SPAN 15.00MHz
*RBW 100kHz *VBW 100kHz SWP 50ms

Band_Edge

LTE 10 MHz Channel Bandwidth

Spectrum 700 MHz

Upper C Path 1

Center: 752 MHz

Span: 15 MHz

RBW: 100 kHz

VBW: 100 kHz

ATTEN 10dB

MKR -22.33dBm

RL 40.5dBm

10dB/

757.00MHz

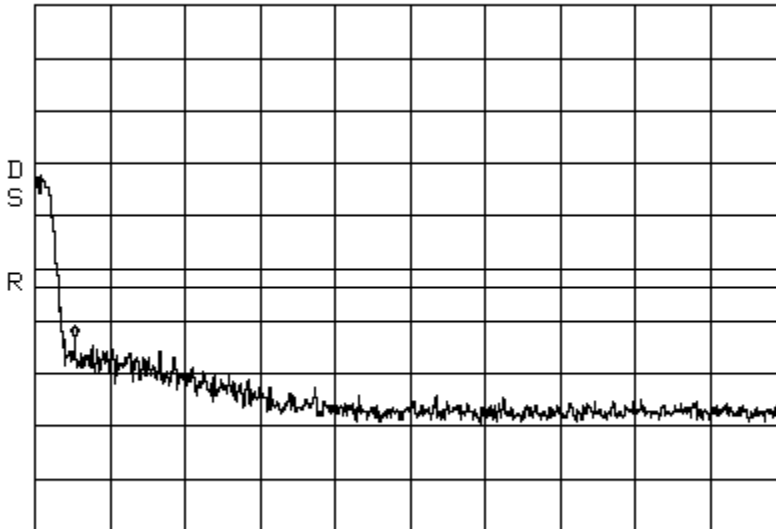

CENTER 763.70MHz SPAN 15.00MHz
*RBW 100kHz *VBW 100kHz SWP 50ms

Band_Edge WCDMA Spectrum AWS Path 1
 Center: 2112.5 MHz Span: 10 MHz RBW: 10 kHz VBW: 10 kHz
 ATTEN 10dB MKR -37.33dBm
 RL 40.5dBm 10dB/ 2.11000GHz

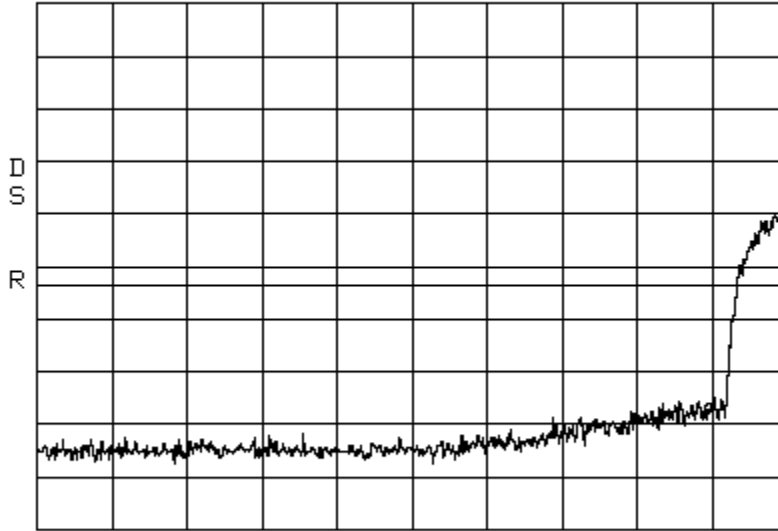

CENTER 2.10605GHz SPAN 10.00MHz
 *RBW 10kHz *VBW 10kHz SWP 250ms

Band_Edge WCDMA Spectrum AWS Path 1
 Center: 2152.5 MHz Span: 10 MHz RBW: 10 kHz VBW: 10 kHz

ATTEN 10dB MKR -35.50dBm
 RL 40.5dBm 10dB/ 2.15500GHz

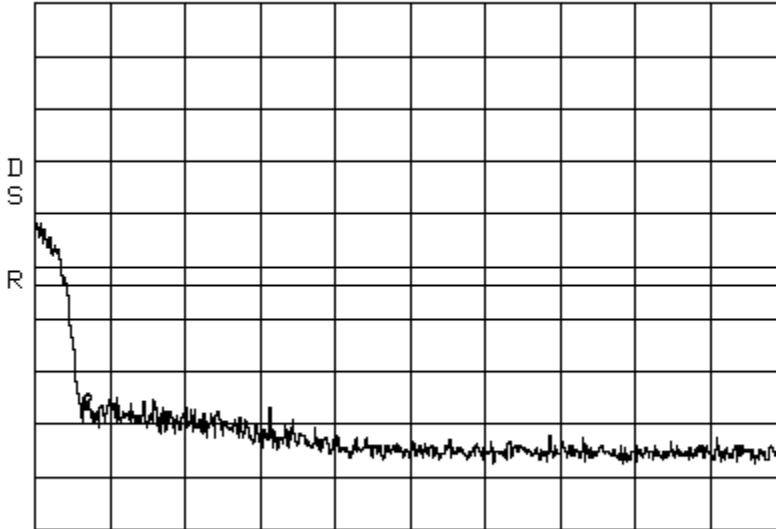

CENTER 2.15930GHz SPAN 10.00MHz
 *RBW 10kHz *VBW 10kHz SWP 250ms

Band_Edge LTE 3 MHz Channel Bandwidth AWS Path 1
 Center: 2111.5 MHz Span: 10 MHz RBW: 30 kHz VBW: 100 kHz
 ATTEN 10dB MKR -25.33dBm
 RL 40.5dBm 10dB/ 2.11000GHz

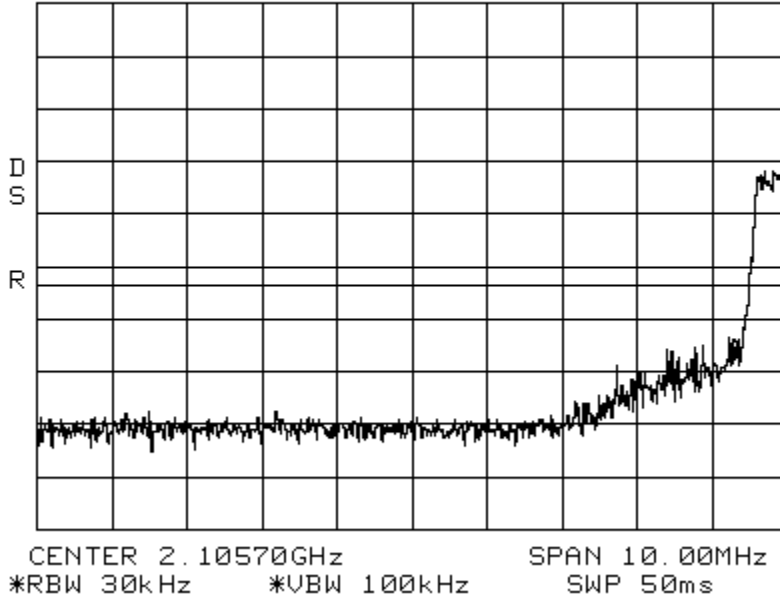

Band_Edge LTE 3MHz Channel Bandwidth AWS Path 1
 Center: 2153.5MHz Span: 10 MHz RBW: 30 kHz VBW: 100 kHz
 ATTEN 10dB MKR -19.50dBm
 RL 40.5dBm 10dB/ 2.15500GHz

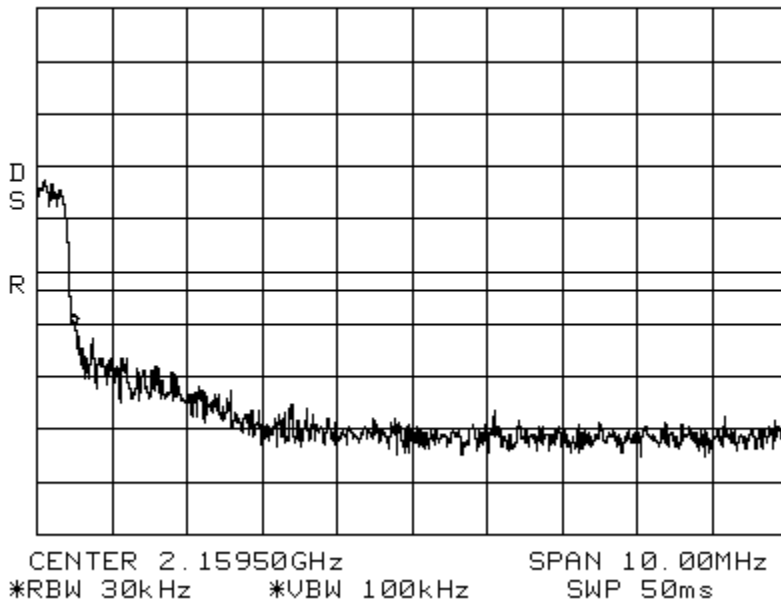

Band_Edge LTE 5 MHz Channel Bandwidth AWS Path 1
Center: 2112.5MHz Span: 10 MHz RBW: 30 kHz VBW: 100 kHz
ATTEN 10dB MKR -25.00dBm
RL 40.5dBm 10dB/ 2.11000GHz

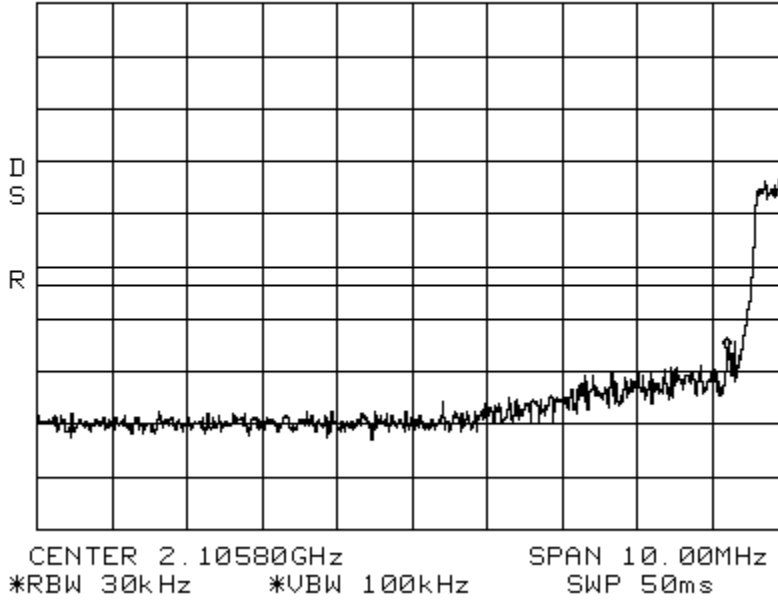

Band_Edge LTE 5 MHz Channel Bandwidth AWS Path 1
Center: 2152.5MHz Span: 10 MHz RBW: 30 kHz VBW: 100 kHz
ATTEN 10dB MKR -32.17dBm
RL 40.5dBm 10dB/ 2.15500GHz

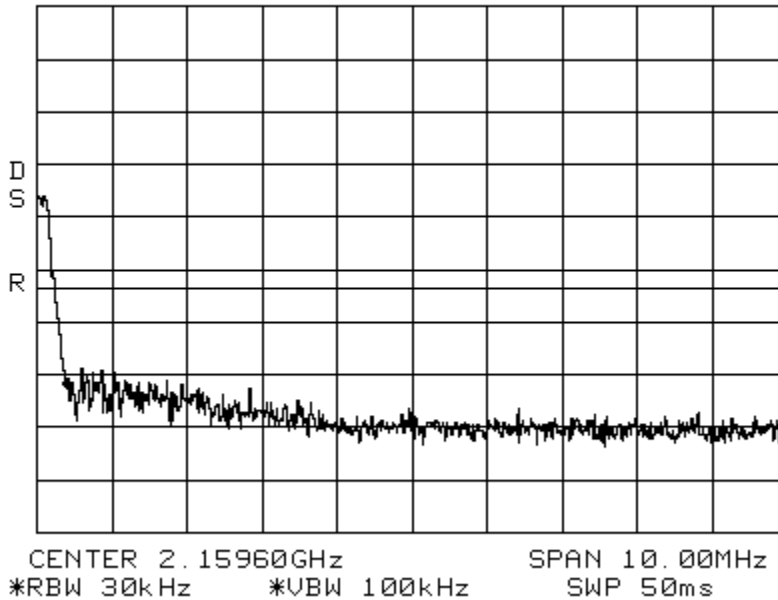

Band_Edge LTE 10 MHz Channel Bandwidth
Center: 2115.0MHz Span: 15 MHz RBW: 100 kHz
ATTEN 10dB MKR -28.83dBm
RL 40.5dBm 10dB/ 2.11000GHz

AWS Path 1
VBW: 100 kHz

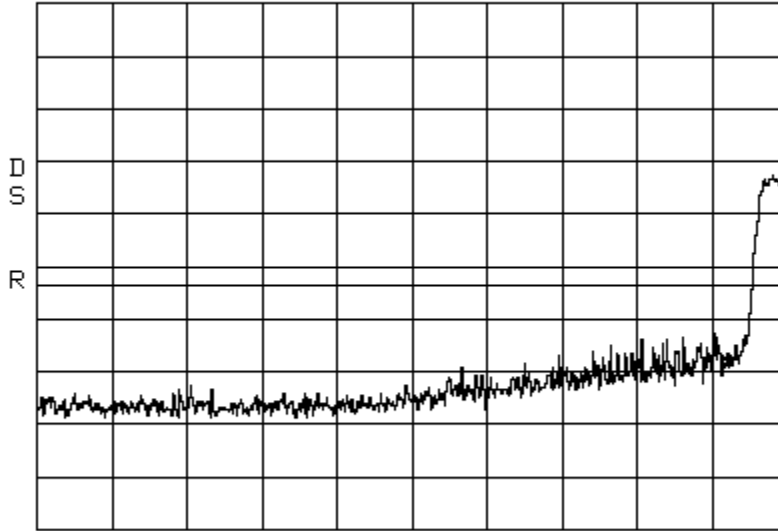

CENTER 2.10375GHz SPAN 15.00MHz
*RBW 100kHz *VBW 100kHz SWP 50ms

Band_Edge LTE 10 MHz Channel Bandwidth
Center: 2150.0MHz Span: 15 MHz RBW: 100 kHz

AWS Path 1
VBW: 100 kHz

ATTEN 10dB MKR -27.83dBm
RL 40.5dBm 10dB/ 2.15500GHz

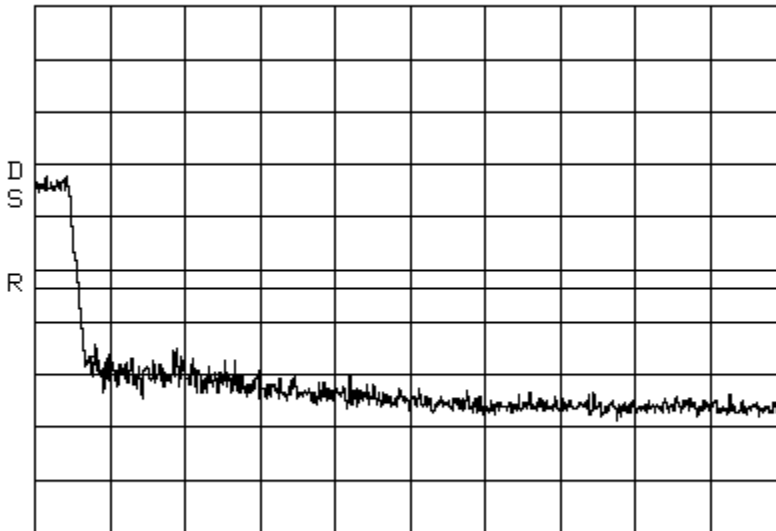

CENTER 2.16133GHz SPAN 15.00MHz
*RBW 100kHz *VBW 100kHz SWP 50ms

Band_Edge LTE 15 MHz Channel Bandwidth
 Center: 2117.5 MHz Span: 15 MHz RBW: 100 kHz
 ATTN 10dB MKR -28.83dBm
 RL 40.5dBm 10dB/ 2.11000GHz

AWS Path 1
 VBW: 100 kHz

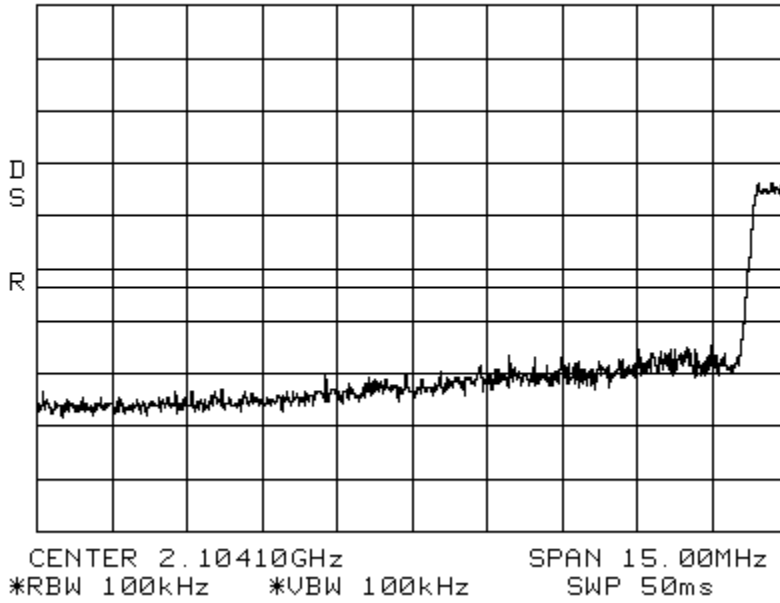

Band_Edge LTE 15 MHz Channel Bandwidth
 Center: 2147.5MHz Span: 15 MHz RBW: 100kHz
 ATTN 10dB MKR -28.83dBm
 RL 40.5dBm 10dB/ 2.15500GHz

AWS Path 1
 VBW: 100 kHz

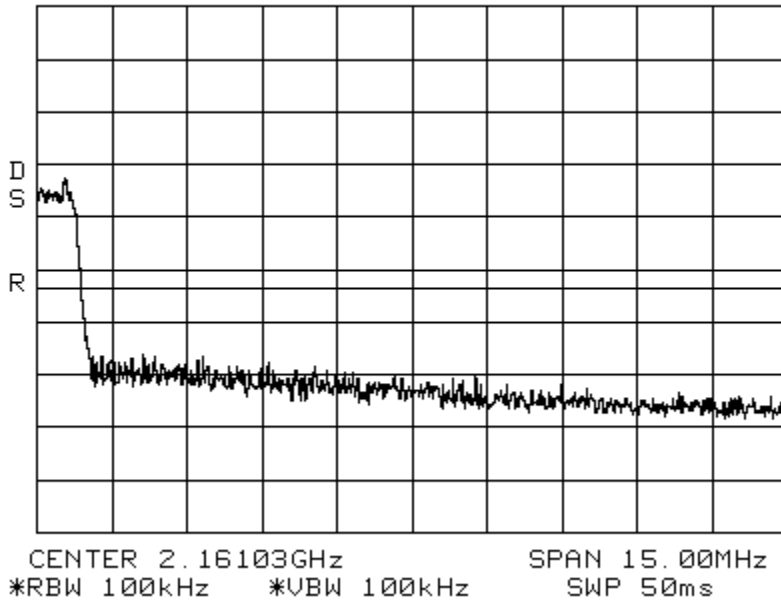

Band_Edge LTE 20 MHz Channel Bandwidth
Center: 2120.0MHz Span: 20 MHz RBW: 100 kHz
ATTEN 10dB MKR -28.67dBm
RL 40.5dBm 10dB/ 2.11000GHz

AWS Path 1
VBW: 100 kHz

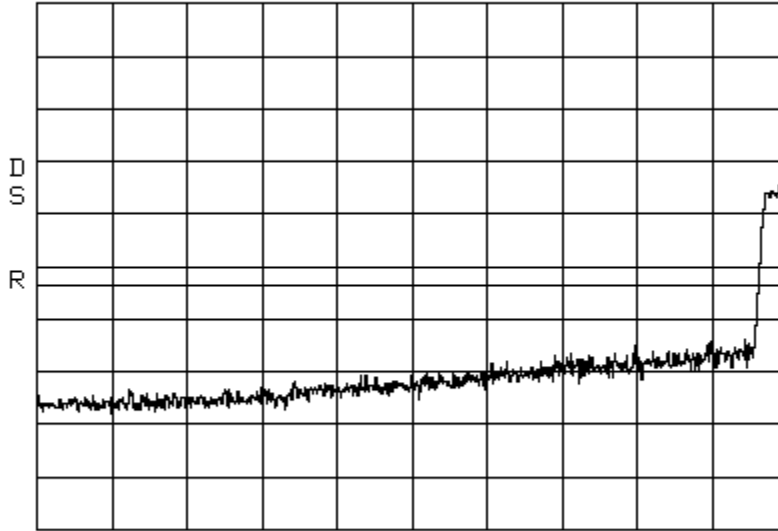

CENTER 2.10190GHz SPAN 20.00MHz
*RBW 100kHz *VBW 100kHz SWP 50ms

Band_Edge LTE 20 MHz Channel Bandwidth
Center: 2145.0MHz Span: 20 MHz RBW: 100 kHz

AWS Path 1
VBW: 100 kHz

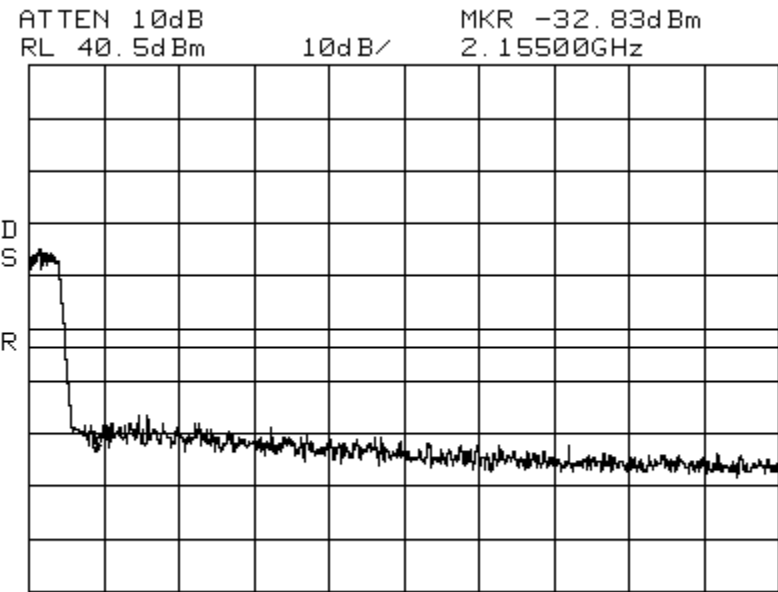

CENTER 2.16320GHz SPAN 20.00MHz
*RBW 100kHz *VBW 100kHz SWP 50ms

7.2 Conducted Output Power Test

[Table of Contents; Section 1.0](#)

[Back to Conducted Output Power; Section 5.1.1](#)

*Note: The EUT is a fixed repeater and not a base station.

This measurement was made as a direct conducted emission measurement. The output from the EUT antenna connector was connected to the power meter. The carrier output, below, was conducted using a single LTE 1.4 MHz, 3 MHz, 5MHz, 10MHz, 15MHz, 20MHz Channel Bandwidths & WCDMA signal generator. The power meter level was offset to compensate for attenuators and cable loss between the EUT and the power meter.

A signal was used at the low, mid and high parts of the selected band.

700 Lower ABC Path 1

LTE 1.4 MHz Ch. BW **0.1051 Watts**

Carrier Frequency	Carrier Output
728.70 MHz	18.92 dBm
737.00 MHz	20.22 dBm
745.30 MHz	19.60 dBm

700 Lower ABC Path 1

LTE 3.0 MHz Ch. BW **0.1288 Watts**

Carrier Frequency	Carrier Output
729.50 MHz	20.09 dBm
737.00 MHz	21.10 dBm
744.50 MHz	20.09 dBm

700 Lower ABC Path 1

LTE 5.0 MHz Ch. BW **0.1106 Watts**

Carrier Frequency	Carrier Output
730.50 MHz	19.75 dBm
737.00 MHz	20.44dBm
743.50 MHz	19.70 dBm

700 Lower ABC Path 1

LTE 10.0 MHz Ch. BW **0.0977 Watts**

Carrier Frequency	Carrier Output
733.00 MHz	19.64 dBm
737.00 MHz	19.90 dBm
741.00 MHz	19.65 dBm

700 Upper C Path 1

LTE 1.4 MHz Ch. BW **0.0954 Watts**

Carrier Frequency	Carrier Output
746.70 MHz	18.76 dBm
751.50 MHz	19.80 dBm
756.30 MHz	18.14 dBm

700 Upper C Path 1
LTE 3.0 MHz Ch. BW 0.1109 Watts

Carrier Frequency	Carrier Output
747.50 MHz	19.78 dBm
751.50 MHz	20.45 dBm
755.50 MHz	19.58 dBm

700 Upper C Path 1
LTE 5.0 MHz Ch. BW 0.0870 Watts

Carrier Frequency	Carrier Output
748.50 MHz	19.02 dBm
751.50 MHz	19.40 dBm
754.50 MHz	18.65 dBm

700 Upper C Path 1
LTE 10.0 MHz Ch. BW 0.0843 Watts

Carrier Frequency	Carrier Output
751.50 MHz	19.26 dBm

AWS Path 1
WCDMA 0.1020 Watts

Carrier Frequency	Carrier Output
2112.5 MHz	<u>20.09</u> dBm
2132.5 MHz	<u>19.72</u> dBm
2152.5 MHz	<u>18.81</u> dBm

AWS Path 1
LTE 3MHz 0.1028 Watts

Carrier Frequency	Carrier Output
2111.5 MHz	<u>20.12</u> dBm
2132.5 MHz	<u>20.07</u> dBm
2153.5 MHz	<u>19.08</u> dBm

AWS Path 1
LTE 5MHz 0.0826 Watts

Carrier Frequency	Carrier Output
2112.5 MHz	<u>19.17</u> dBm
2132.5 MHz	<u>19.16</u> dBm
2152.5 MHz	<u>18.10</u> dBm

AWS Path 1
LTE 10MHz 0.0939 Watts

Carrier Frequency	Carrier Output
2115.0 MHz	<u>19.73</u> dBm
2132.5 MHz	<u>19.17</u> dBm
2150.0 MHz	<u>18.17</u> dBm

AWS Path 1
LTE 15MHz 0.0883 Watts

Carrier Frequency	Carrier Output
2117.5 MHz	<u>19.46</u> dBm
2132.5 MHz	<u>18.17</u> dBm
2147.5 MHz	<u>17.83</u> dBm

AWS Path 1

LTE 20MHz 0.0814 Watts

Carrier Frequency	Carrier Output
2120.0 MHz	<u>19.11</u> dBm
2132.5 MHz	<u>18.66</u> dBm
2145.0 MHz	<u>18.13</u> dBm

7.3 Frequency Stability Test

[Table of Contents; Section 1.0](#)
[Back to Frequency Stability; Section 5.1.1](#)

Host/DRU	IFEU	RAU			
Input Voltage	Input Voltage	Input Voltage	Carrier Frequency	Measured Frequency	Meets Requirements?
100 VAC	54VDC	54 VDC	2110.200 MHz	2110.200 MHz	Yes
170 VAC	54VDC	54 VDC	2110.200 MHz	2110.200 MHz	Yes
240 VAC	54VDC	54 VDC	2110.200 MHz	2110.200 MHz	Yes
100 VAC	54VDC	54 VDC	2132.500 MHz	2132.500 MHz	Yes
170 VAC	54VDC	54 VDC	2132.500 MHz	2132.500 MHz	Yes
240 VAC	54VDC	54 VDC	2132.500 MHz	2132.500 MHz	Yes
100 VAC	54VDC	54 VDC	2154.800 MHz	2154.800 MHz	Yes
170 VAC	54VDC	54 VDC	2154.800 MHz	2154.800 MHz	Yes
240 VAC	54VDC	54 VDC	2154.800 MHz	2154.800 MHz	Yes
Temperature			Carrier Frequency	Measured Frequency	Meets Requirements?
-25 Deg. C			2110.200 MHz	2110.200 MHz	Yes
-20 Deg. C			2110.200 MHz	2110.200 MHz	Yes
-10 Deg. C			2110.200 MHz	2110.200 MHz	Yes
0 Deg. C			2110.200 MHz	2110.200 MHz	Yes
10 Deg. C			2110.200 MHz	2110.200 MHz	Yes
20 Deg. C			2110.200 MHz	2110.200 MHz	Yes
30 Deg. C			2110.200 MHz	2110.200 MHz	Yes
40 Deg. C			2110.200 MHz	2110.200 MHz	Yes
45 Deg. C			2110.200 MHz	2110.200 MHz	Yes
50 Deg. C			2110.200 MHz	2110.200 MHz	Yes
-25 Deg. C			2132.500 MHz	2132.500 MHz	Yes
-20 Deg. C			2132.500 MHz	2132.500 MHz	Yes
-10 Deg. C			2132.500 MHz	2132.500 MHz	Yes
0 Deg. C			2132.500 MHz	2132.500 MHz	Yes
10 Deg. C			2132.500 MHz	2132.500 MHz	Yes
20 Deg. C			2132.500 MHz	2132.500 MHz	Yes
30 Deg. C			2132.500 MHz	2132.500 MHz	Yes
40 Deg. C			2132.500 MHz	2132.500 MHz	Yes
45 Deg. C			2132.500 MHz	2132.500 MHz	Yes
50 Deg. C			2132.500 MHz	2132.500 MHz	Yes
-25 Deg. C			2154.800 MHz	2154.800 MHz	Yes
-20 Deg. C			2154.800 MHz	2154.800 MHz	Yes
-10 Deg. C			2154.800 MHz	2154.800 MHz	Yes
0 Deg. C			2154.800 MHz	2154.800 MHz	Yes
10 Deg. C			2154.800 MHz	2154.800 MHz	Yes
20 Deg. C			2154.800 MHz	2154.800 MHz	Yes
30 Deg. C			2154.800 MHz	2154.800 MHz	Yes
40 Deg. C			2154.800 MHz	2154.800 MHz	Yes
45 Deg. C			2154.800 MHz	2154.800 MHz	Yes
50 Deg. C			2154.800 MHz	2154.800 MHz	Yes

Host/DRU	IFEU	RAU			
Input Voltage	Input Voltage	Input Voltage	Carrier Frequency	Measured Frequency	Meets Requirements?
100 VAC	54VDC	54 VDC	728.200 MHz	728.200 MHz	Yes
170 VAC	54VDC	54 VDC	728.200 MHz	728.200 MHz	Yes
240 VAC	54VDC	54 VDC	728.200 MHz	728.200 MHz	Yes
100 VAC	54VDC	54 VDC	742.000 MHz	742.000 MHz	Yes
170 VAC	54VDC	54 VDC	742.000 MHz	742.000 MHz	Yes
240 VAC	54VDC	54 VDC	742.000 MHz	742.000 MHz	Yes
100 VAC	54VDC	54 VDC	756.800 MHz	756.800 MHz	Yes
170 VAC	54VDC	54 VDC	756.800 MHz	756.800 MHz	Yes
240 VAC	54VDC	54 VDC	756.800 MHz	756.800 MHz	Yes
Temperature			Carrier Frequency	Measured Frequency	Meets Requirements?
-25 Deg. C			728.200 MHz	728.200 MHz	Yes
-20 Deg. C			728.200 MHz	728.200 MHz	Yes
-10 Deg. C			728.200 MHz	728.200 MHz	Yes
0 Deg. C			728.200 MHz	728.200 MHz	Yes
10 Deg. C			728.200 MHz	728.200 MHz	Yes
20 Deg. C			728.200 MHz	728.200 MHz	Yes
30 Deg. C			728.200 MHz	728.200 MHz	Yes
40 Deg. C			728.200 MHz	728.200 MHz	Yes
45 Deg. C			728.200 MHz	728.200 MHz	Yes
50 Deg. C			728.200 MHz	728.200 MHz	Yes
-25 Deg. C			742.000 MHz	742.000 MHz	Yes
-20 Deg. C			742.000 MHz	742.000 MHz	Yes
-10 Deg. C			742.000 MHz	742.000 MHz	Yes
0 Deg. C			742.000 MHz	742.000 MHz	Yes
10 Deg. C			742.000 MHz	742.000 MHz	Yes
20 Deg. C			742.000 MHz	742.000 MHz	Yes
30 Deg. C			742.000 MHz	742.000 MHz	Yes
40 Deg. C			742.000 MHz	742.000 MHz	Yes
45 Deg. C			742.000 MHz	742.000 MHz	Yes
50 Deg. C			742.000 MHz	742.000 MHz	Yes
-25 Deg. C			756.800 MHz	756.800 MHz	Yes
-20 Deg. C			756.800 MHz	756.800 MHz	Yes
-10 Deg. C			756.800 MHz	756.800 MHz	Yes
0 Deg. C			756.800 MHz	756.800 MHz	Yes
10 Deg. C			756.800 MHz	756.800 MHz	Yes
20 Deg. C			756.800 MHz	756.800 MHz	Yes
30 Deg. C			756.800 MHz	756.800 MHz	Yes
40 Deg. C			756.800 MHz	756.800 MHz	Yes
45 Deg. C			756.800 MHz	756.800 MHz	Yes
50 Deg. C			756.800 MHz	756.800 MHz	Yes

7.4 Intermodulation Test

[Table of Contents; Section 1.0](#)

[Back to Emission Limits; Section 5.1.3](#)

The inter-modulation products test was performed for the EUT. Three tests were performed with the modulation type. Test 1 was with 2 signals input to the EUT at lower end channels. Test 2 was with 2 signals input to the EUT at upper end channels. Test 3 was with 2 signals input to the EUT at upper and lower end channels. The modulation types tested were LTE 1.4 MHz, 3 MHz, 5MHz, 10MHz, 15MHz, 20MHz Channel Bandwidths, & WCDMA. An investigation was made from 30 MHz to the 10th Harmonic of the highest fundamental frequency (~20 GHz). The following plots show the results.

Results:
(See Plots)

Intermodulation

LTE 1.4 MHz Channel Bandwidth_Low

Spectrum 700 MHz

Center: 737 MHz

Lower ABC Path 1

Span: 35 MHz

RBW/VBW: 100 kHz

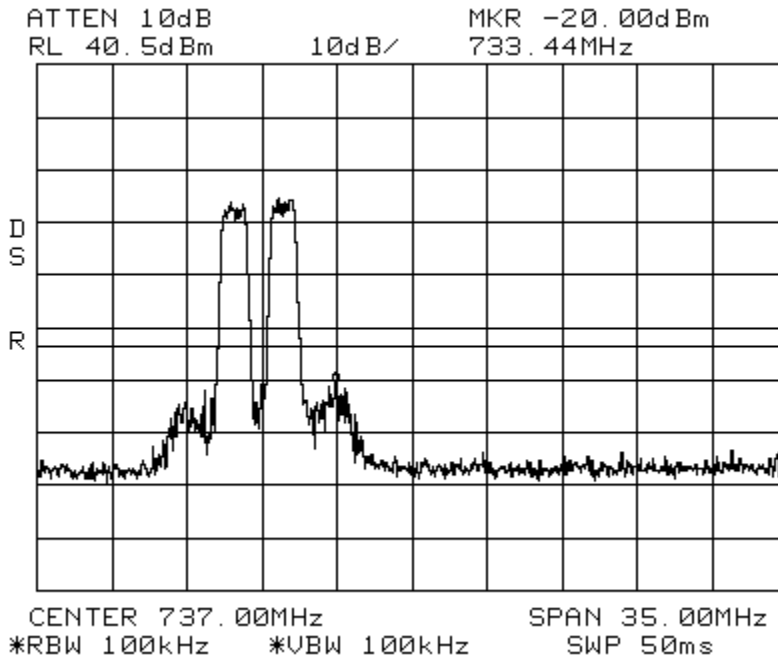

Intermodulation

LTE 1.4 MHz Channel Bandwidth_Low

Spectrum 700 MHz

Lower ABC Path 1

Span: 30 MHz to 1 GHz

RBW/VBW: 300 kHz

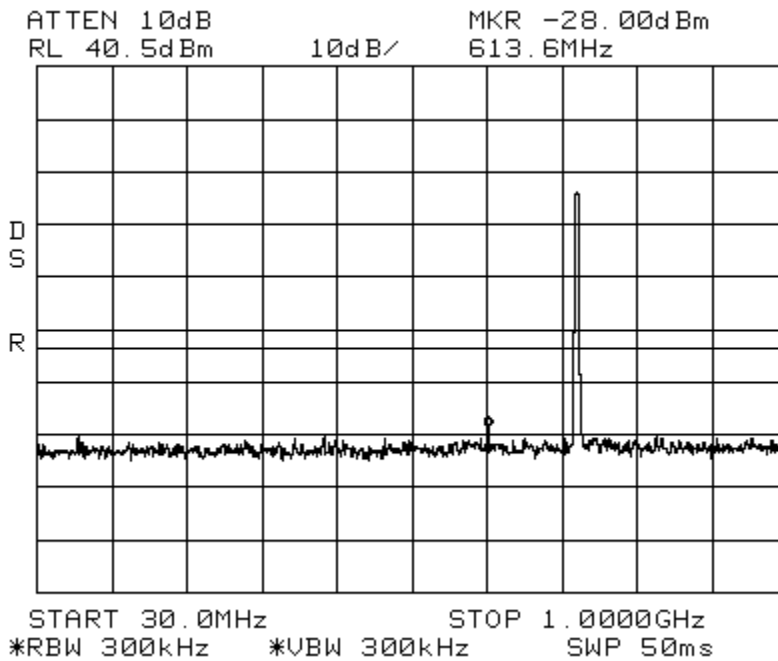

Intermodulation

LTE 1.4 MHz Channel Bandwidth _Low
Lower ABC Path 1

Spectrum 700 MHz

Span: 1 GHz to 10 GHz

RBW/VBW: 1 MHz

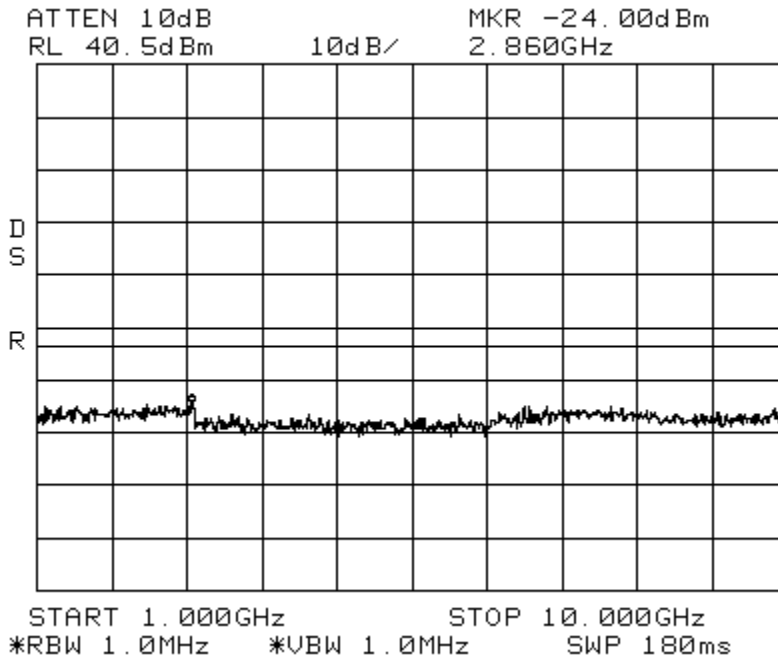

Intermodulation

LTE 1.4 MHz Channel Bandwidth _High
MHz Lower ABC Path 1

Spectrum 700

Center: 737 MHz

Span: 35 MHz

RBW/VBW: 100 kHz

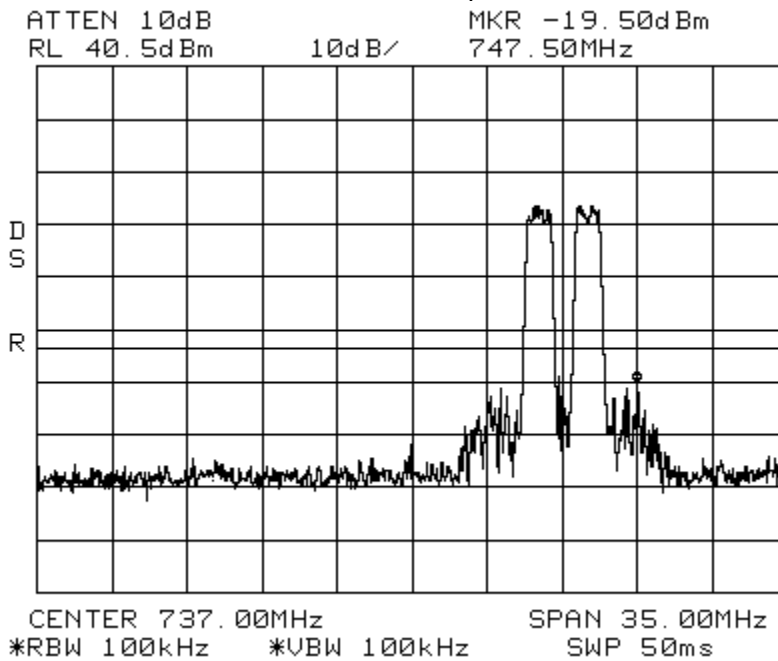

Intermodulation

LTE 1.4 MHz Channel Bandwidth _High
Lower ABC Path 1

Spectrum 700 MHz

Span: 30 MHz to 1 GHz

RBW/VBW: 300 kHz

ATTEN 10dB

MKR -29.17dBm

RL 40.5dBm

10dB/

694.5MHz

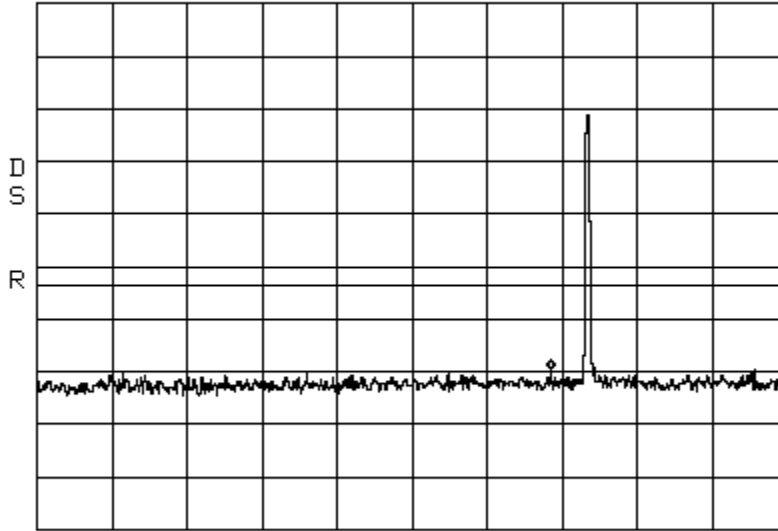

START 30.0MHz

STOP 1.0000GHz

*RBW 300kHz

*VBW 300kHz

SWP 50ms

Intermodulation

LTE 1.4 MHz Channel Bandwidth _High
Lower ABC Path 1

Spectrum 700 MHz

Span: 1 GHz to 10 GHz

RBW/VBW: 1 MHz

ATTEN 10dB

MKR -22.83dBm

RL 40.5dBm

10dB/

2.380GHz

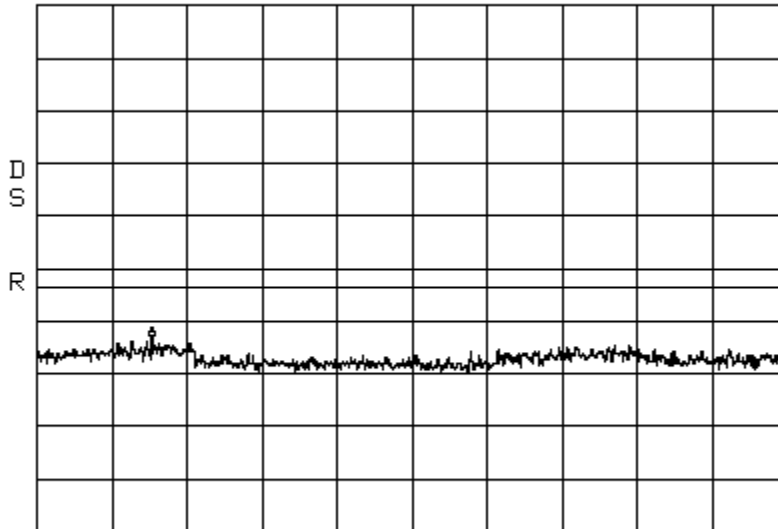

START 1.000GHz

STOP 10.000GHz

*RBW 1.0MHz

*VBW 1.0MHz

SWP 180ms

Intermodulation

LTE 1.4 MHz Channel Bandwidth _Apart

Spectrum 700 MHz

Lower ABC Path 1

Center: 737 MHz

Span: 70 MHz

RBW/VBW: 100 kHz

ATTEN 10dB

MKR -32.50dBm

RL 40.5dBm

10dB/

762.55MHz

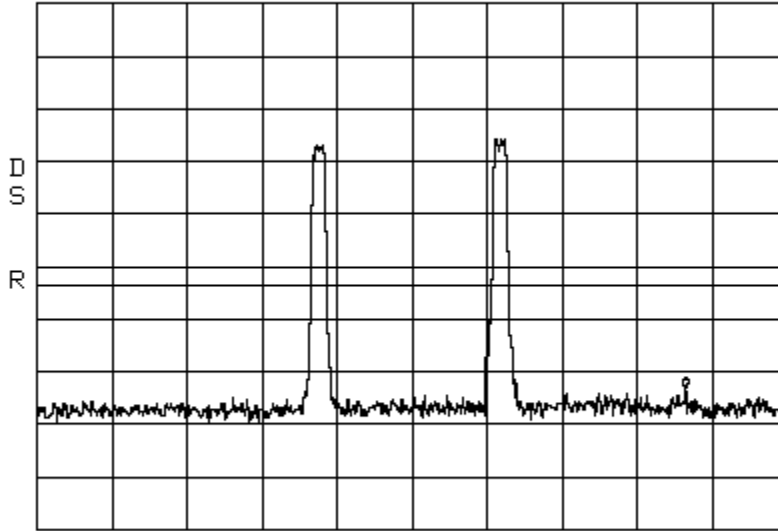

CENTER 737.00MHz SPAN 70.00MHz
*RBW 100kHz *VBW 100kHz SWP 50ms

Intermodulation

LTE 1.4 MHz Channel Bandwidth _Apart

Spectrum 700 MHz

Lower ABC Path 1

Span: 30 MHz to 1 GHz

RBW/VBW: 300 kHz

ATTEN 10dB

MKR -28.50dBm

RL 40.5dBm

10dB/

915.9MHz

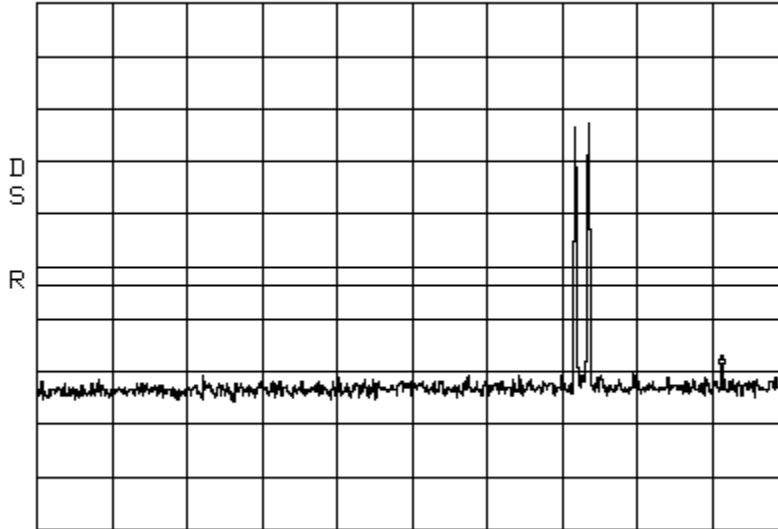

START 30.0MHz STOP 1.0000GHz
*RBW 300kHz *VBW 300kHz SWP 50ms

Intermodulation

LTE 1.4 MHz Channel Bandwidth_Apart
Lower ABC Path 1

Spectrum 700 MHz

Span: 1 GHz to 10 GHz

RBW/VBW: 1 MHz

ATTEN 10dB

MKR -22.83dBm

RL 40.5dBm

10dB/

7.960GHz

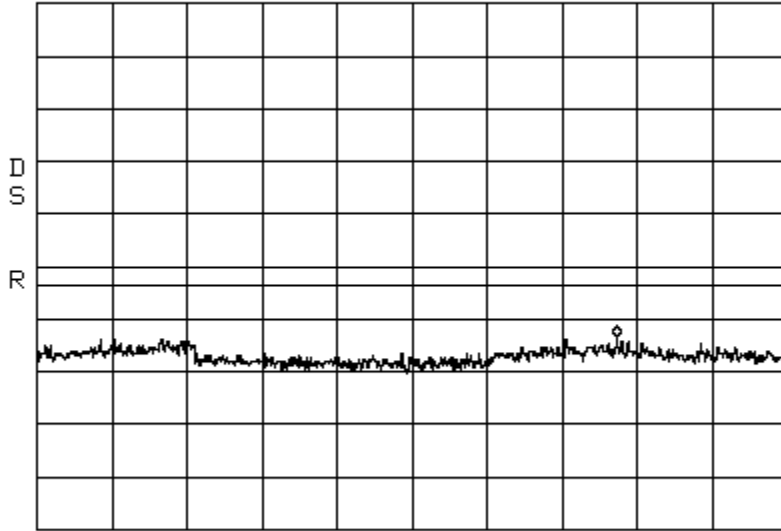

START 1.000GHz STOP 10.000GHz
*RBW 1.0MHz *VBW 1.0MHz SWP 180ms

Intermodulation

LTE 3 MHz Channel Bandwidth_Low
Lower ABC Path 1

Spectrum 700 MHz

Center: 737 MHz

Span: 35 MHz

RBW/VBW: 100 kHz

ATTEN 10dB

MKR -19.50dBm

RL 40.5dBm

10dB/

736.01MHz

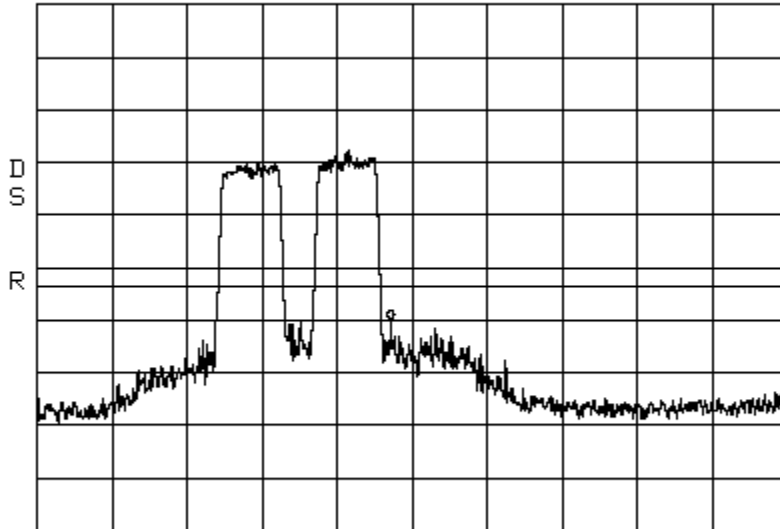

CENTER 737.00MHz SPAN 35.00MHz
*RBW 100kHz *VBW 100kHz SWP 50ms

Intermodulation

LTE 3MHz Channel Bandwidth _LowSpectrum 700 MHz Lower ABC
Path 1

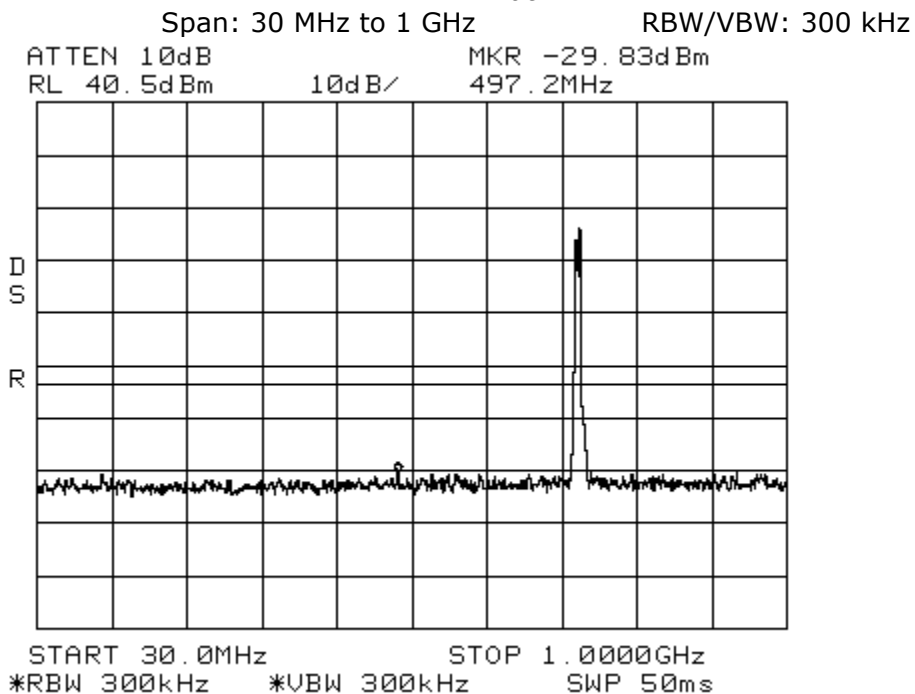

Intermodulation

LTE 3 MHz Channel Bandwidth _Low
Lower ABC Path 1

Spectrum 700 MHz

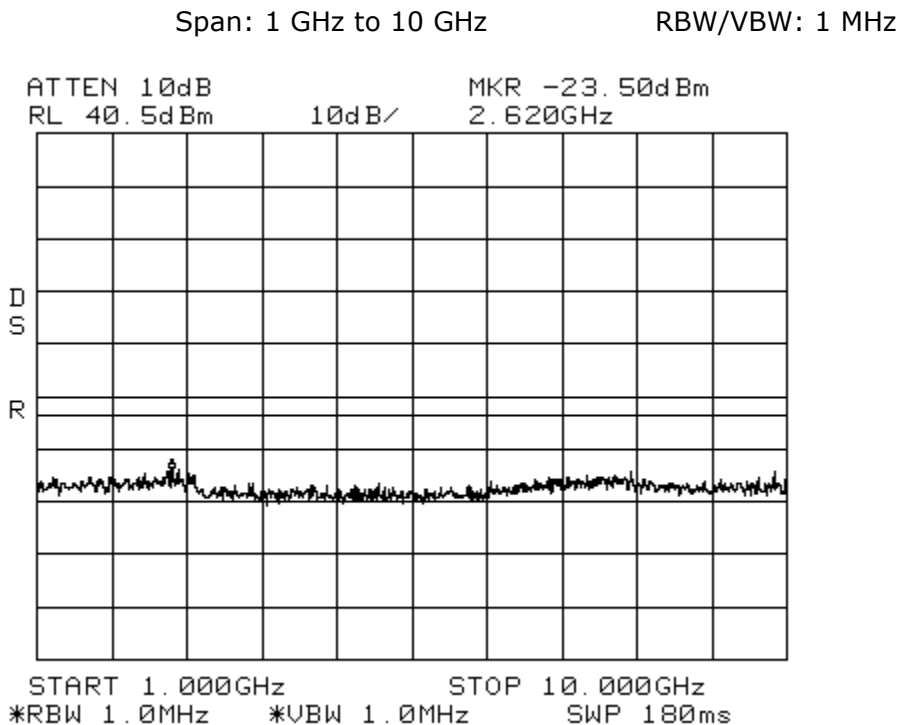

Intermodulation

LTE 3 MHz Channel Bandwidth _High

Spectrum 700 MHz

Lower ABC Path 1

Center: 737 MHz

Span: 35 MHz

RBW/VBW: 100 kHz

ATTEN 10dB

MKR -22.33dBm

RL 40.5dBm

10dB/

737.41MHz

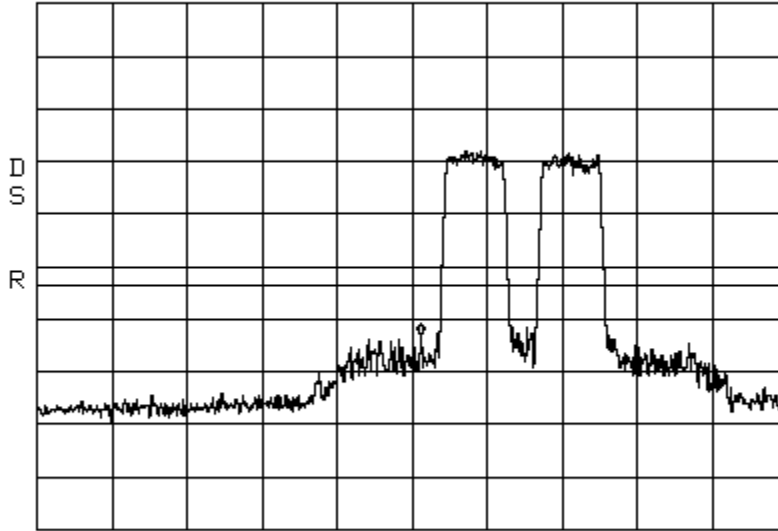

CENTER 737.00MHz SPAN 35.00MHz
*RBW 100kHz *VBW 100kHz SWP 50ms

Intermodulation

LTE 3 MHz Channel Bandwidth _High

Spectrum 700 MHz

Lower ABC Path 1

Span: 30 MHz to 1 GHz

RBW/VBW: 300 kHz

*ATTEN 10dB

MKR -28.33dBm

RL 31.5dBm

10dB/

838.3MHz

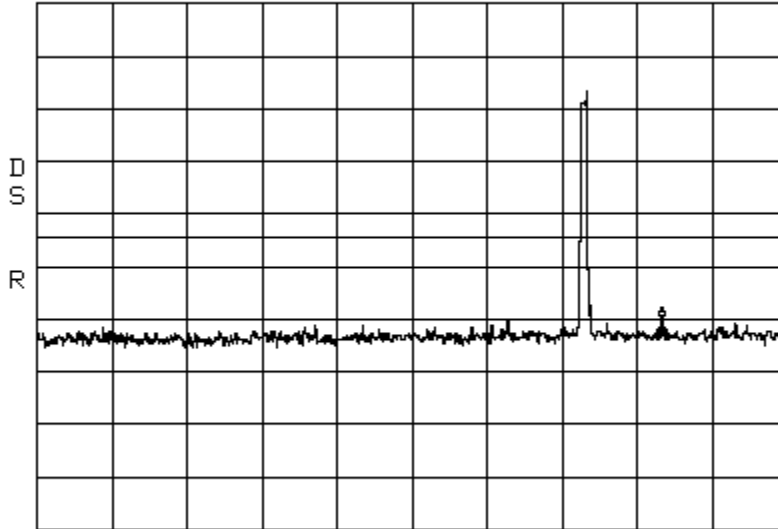

START 30.0MHz STOP 1.0000GHz
*RBW 300kHz *VBW 300kHz SWP 50ms

Intermodulation

LTE 3 MHz Channel Bandwidth _Apart
Lower ABC Path 1

Spectrum 700 MHz

Span: 30 MHz to 1 GHz

RBW/VBW: 300 kHz

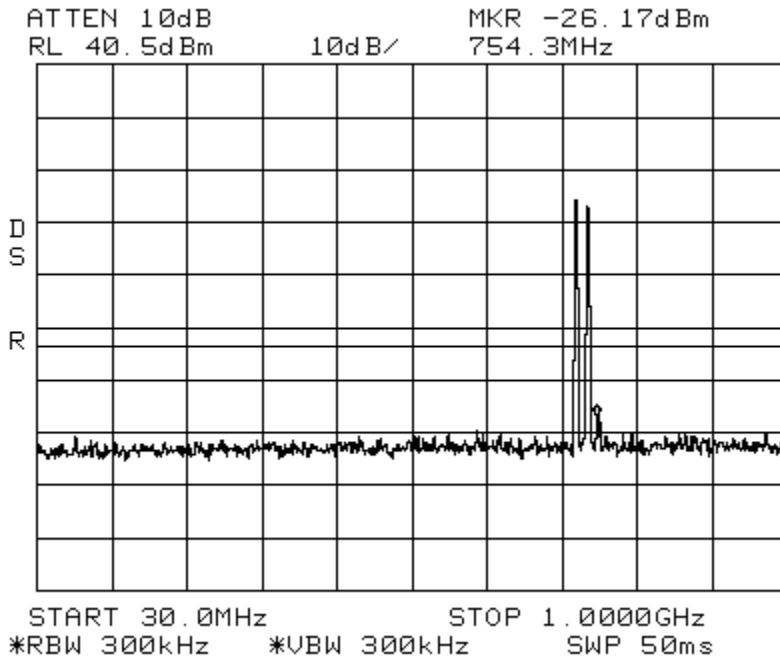

Intermodulation

LTE 3 MHz Channel Bandwidth _Apart
Lower ABC Path 1

Spectrum 700 MHz

Span: 1 GHz to 10 GHz

RBW/VBW: 1 MHz

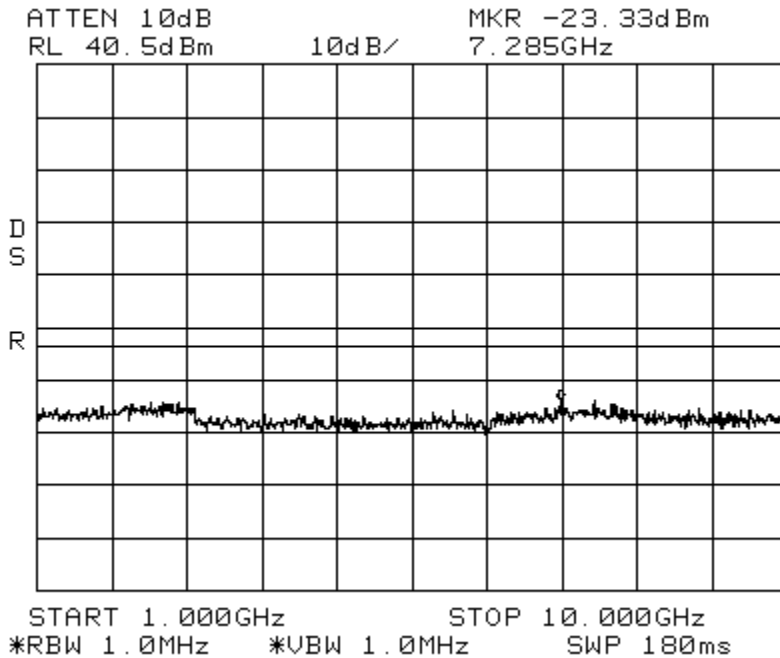

Center: 737 MHz

Span: 35 MHz

RBW/VBW: 100 kHz

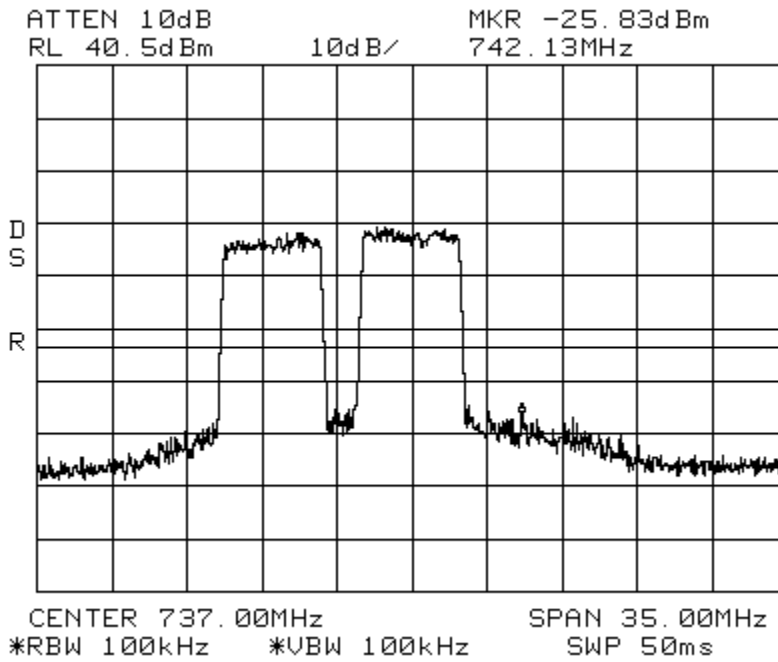

Span: 30 MHz to 1 GHz

RBW/VBW: 300 kHz

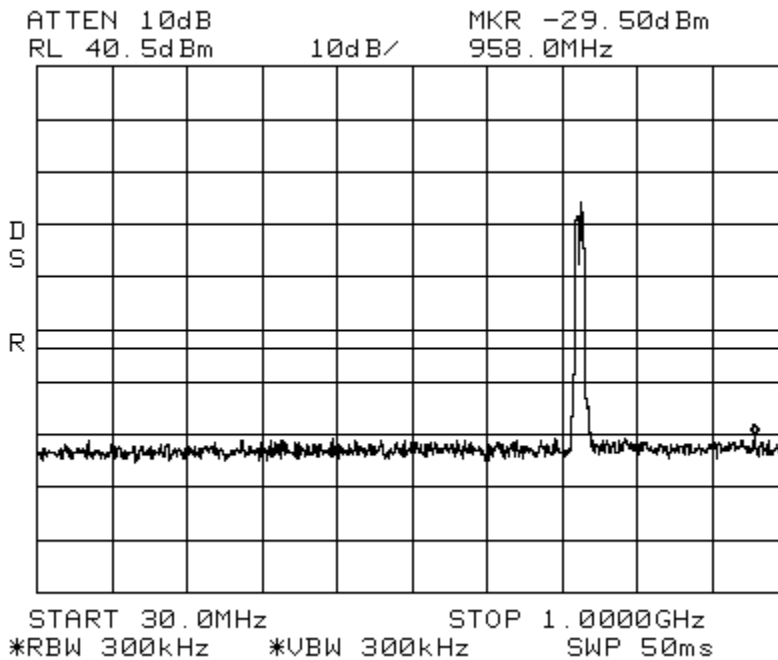

Intermodulation

LTE 5 MHz Channel Bandwidth _High
Lower ABC Path 1

Spectrum 700 MHz

Span: 30 MHz to 1 GHz

RBW/VBW: 300 kHz

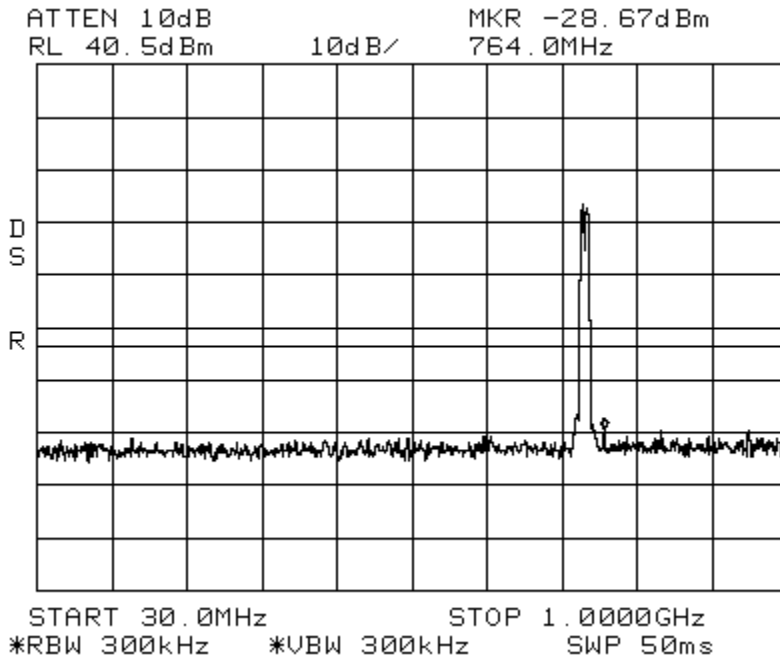

Intermodulation

LTE 5 MHz Channel Bandwidth _High
Lower ABC Path 1

Spectrum 700 MHz

Span: 1 GHz to 10 GHz

RBW/VBW: 1 MHz

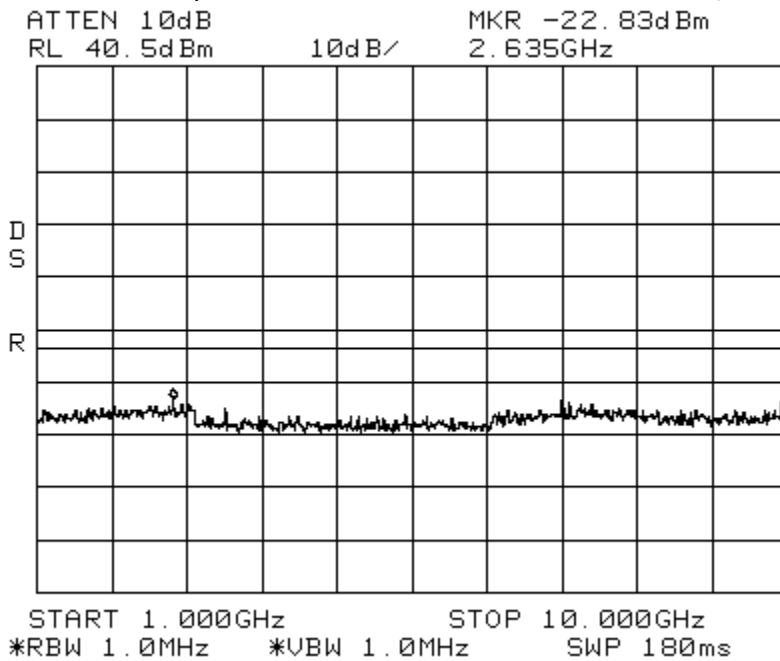

Intermodulation

LTE 5 MHz Channel Bandwidth **Apart**

Spectrum 700 MHz

Center: 737 MHz

Lower ABC Path 1

Span: 70 MHz

RBW/VBW: 100 kHz

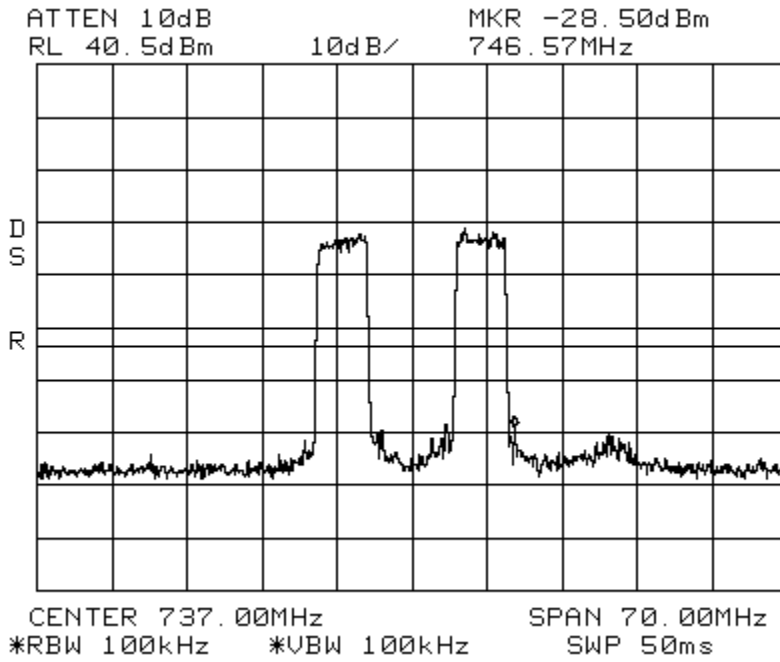

Intermodulation

LTE 5 MHz Channel Bandwidth **Apart**

Spectrum 700 MHz

Lower ABC Path 1

Span: 30 MHz to 1 GHz

RBW/VBW: 300 kHz

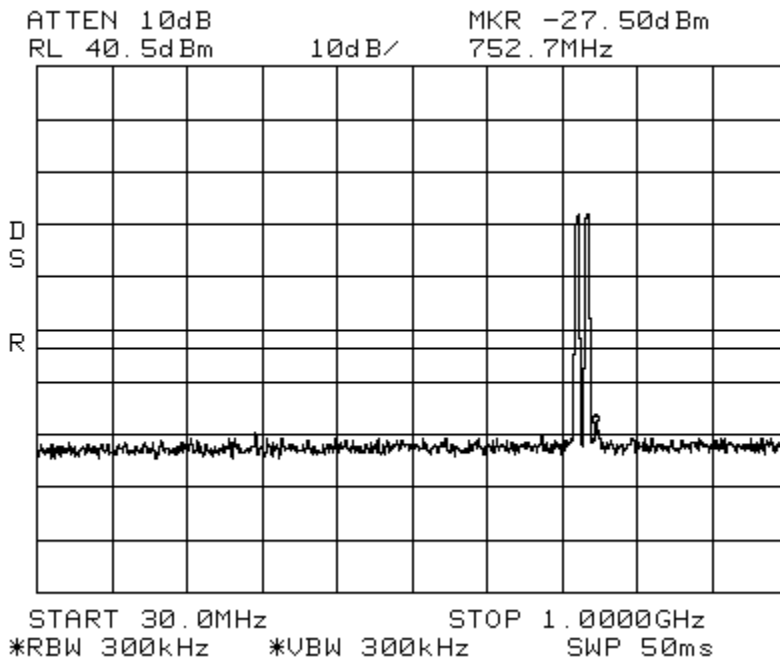

Intermodulation

LTE 5 MHz Channel Bandwidth _Apart
Lower ABC Path 1

Spectrum 700 MHz

Span: 1 GHz to 10 GHz

RBW/VBW: 1 MHz

ATTEN 10dB

MKR -23.17dBm

RL 40.5dBm

10dB/

2.290GHz

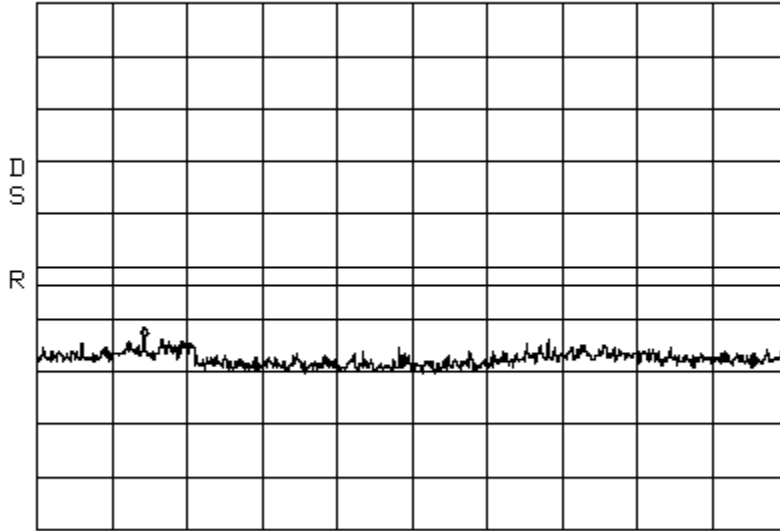

START 1.000GHz STOP 10.000GHz
*RBW 1.0MHz *VBW 1.0MHz SWP 180ms

Intermodulation

LTE 1.4 MHz Channel Bandwidth _Low
Upper C Path 1

Spectrum 700 MHz

Center: 751.5 MHz

Span: 35 MHz

RBW/VBW: 100 kHz

ATTEN 10dB

MKR -17.17dBm

RL 40.5dBm

10dB/

743.63MHz

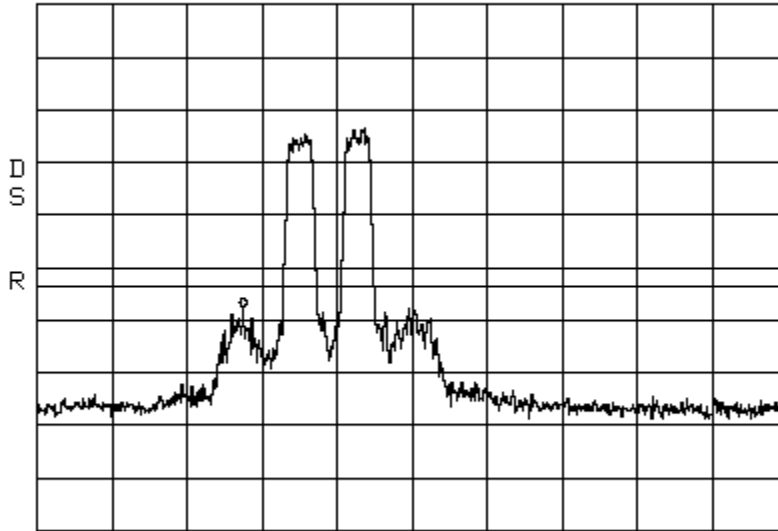

CENTER 751.50MHz SPAN 35.00MHz
*RBW 100kHz *VBW 100kHz SWP 50ms

Intermodulation

LTE 1.4 MHz Channel Bandwidth _Low
Upper C Path 1

Spectrum 700 MHz

Span: 30 MHz to 1 GHz

RBW/VBW: 300 kHz

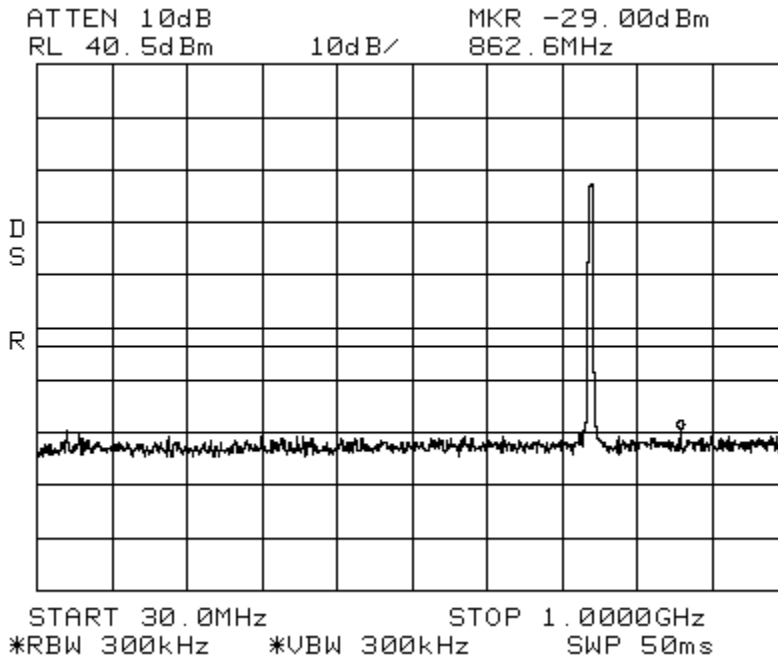

Intermodulation

LTE 1.4 MHz Channel Bandwidth _Low
Upper C Path 1

Spectrum 700 MHz

Span: 1 GHz to 10 GHz

RBW/VBW: 1 MHz

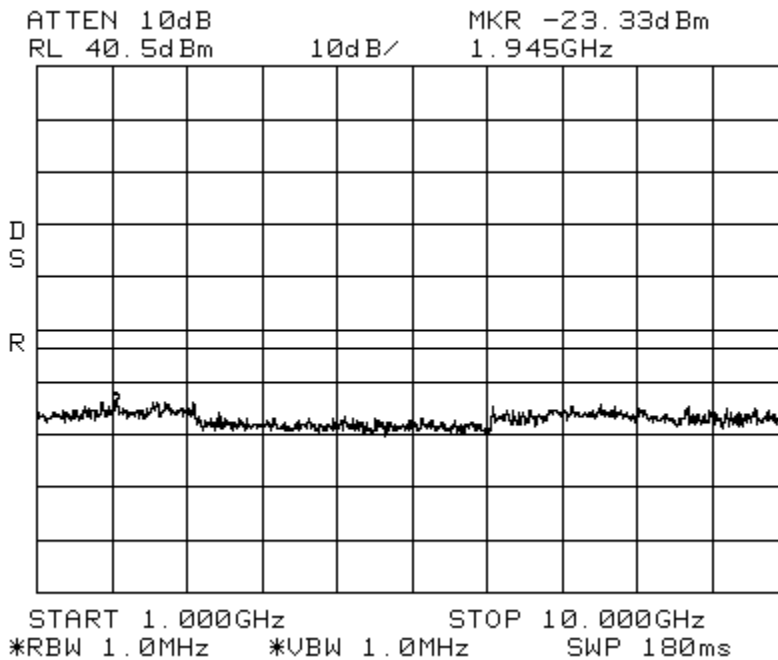

Intermodulation

LTE 1.4 MHz Channel Bandwidth _High
MHz Upper C Path 1

Spectrum 700

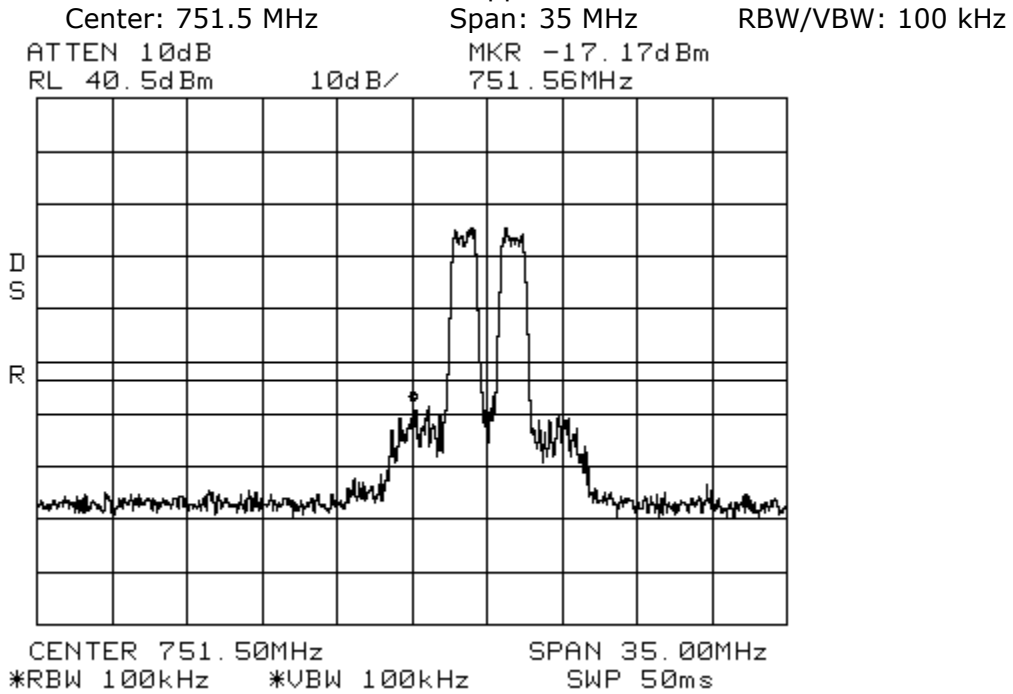

Intermodulation

LTE 1.4 MHz Channel Bandwidth _High
Upper C Path 1

Spectrum 700 MHz

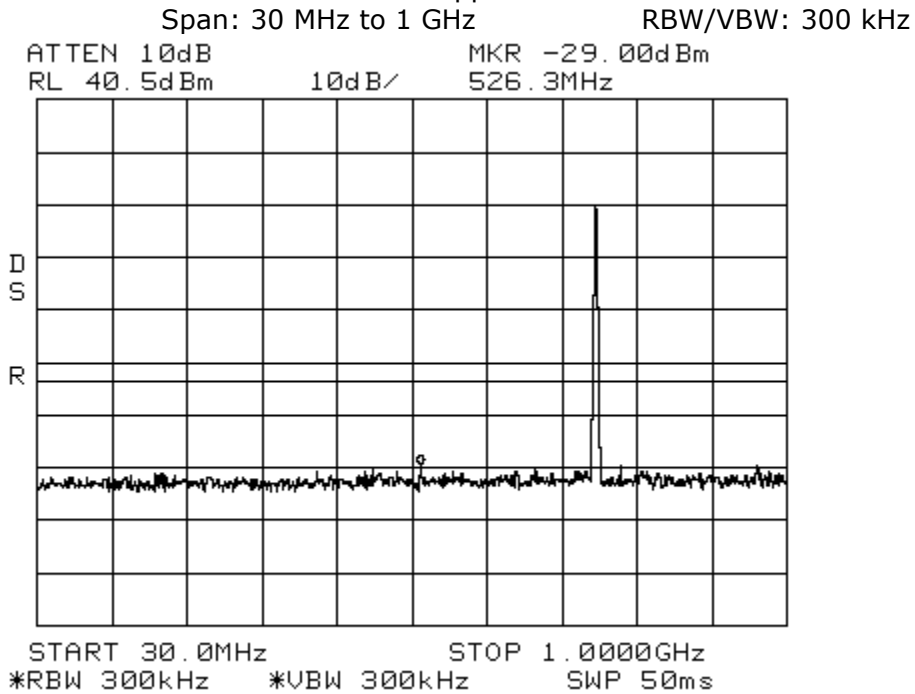

Intermodulation

LTE 1.4 MHz Channel Bandwidth _High
Upper C Path 1

Spectrum 700 MHz

Span: 1 GHz to 10 GHz

RBW/VBW: 1 MHz

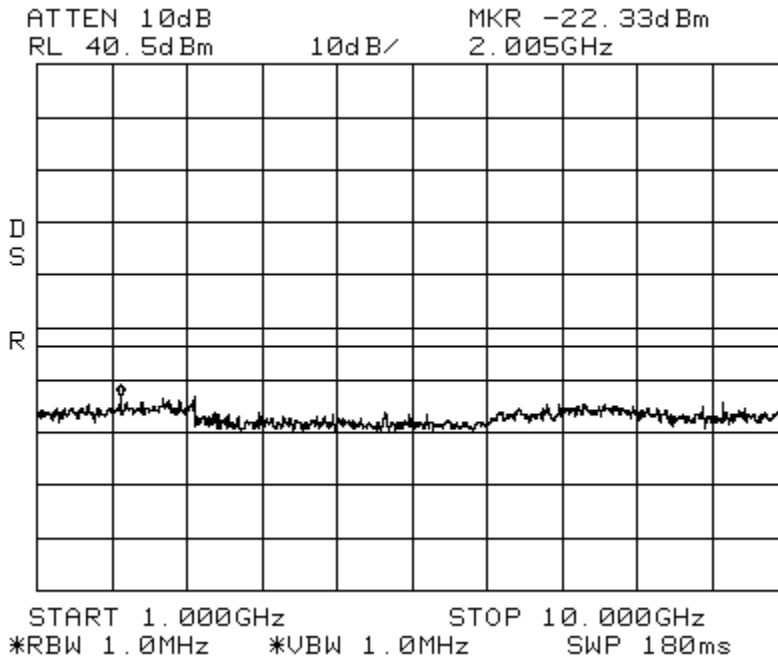

Intermodulation

LTE 1.4 MHz Channel Bandwidth _Apart
Upper C Path 1

Spectrum 700 MHz

Center: 751.5 MHz

Span: 70 MHz

RBW/VBW: 100 kHz

ATTEN 10dB
RL 40.5dBm 10dB/ MKR -23.33dBm
737.15MHz

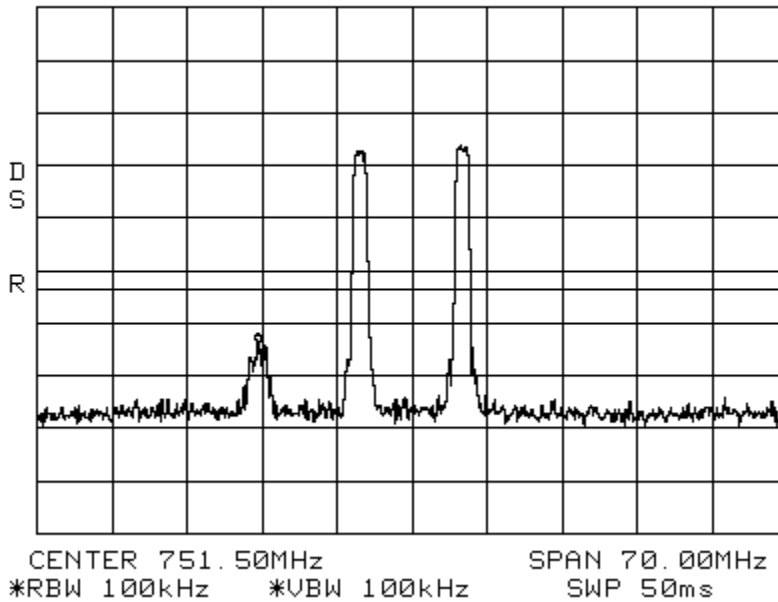

Intermodulation

LTE 1.4 MHz Channel Bandwidth _Apart
Upper C Path 1

Spectrum 700 MHz

Span: 30 MHz to 1 GHz

RBW/VBW: 300 kHz

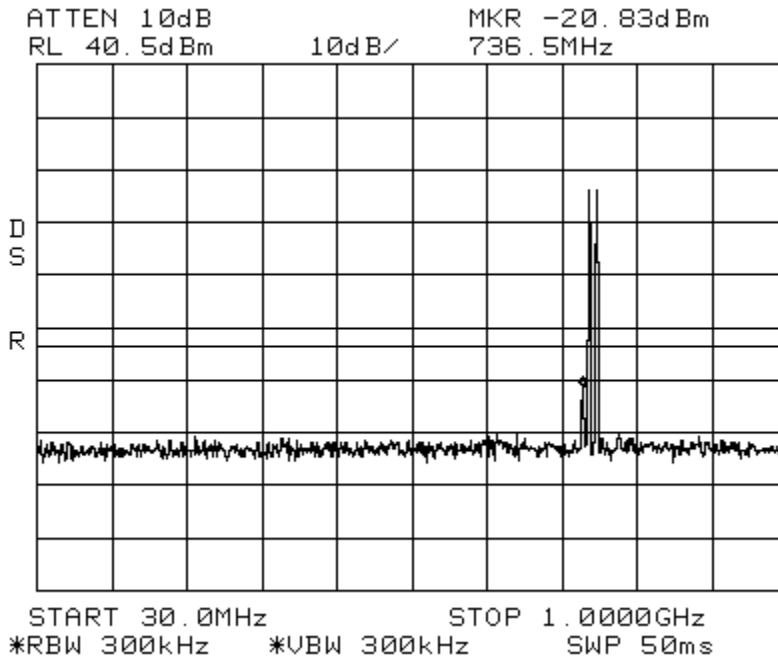

Intermodulation

LTE 1.4 MHz Channel Bandwidth _Apart
Upper C Path 1

Spectrum 700 MHz

Span: 1 GHz to 10 GHz

RBW/VBW: 1 MHz

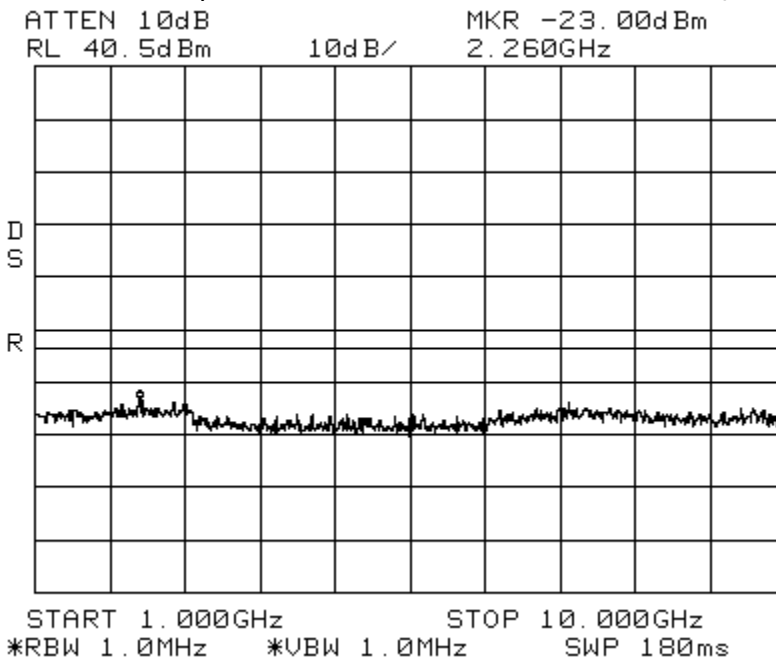

Intermodulation

LTE 3 MHz Channel Bandwidth_Low

Spectrum 700 MHz

Upper C Path 1

Center: 751.5 MHz

Span: 35 MHz

RBW/VBW: 100 kHz

ATTEN 10dB

MKR -19.33dBm

RL 40.5dBm

10dB/

745.32MHz

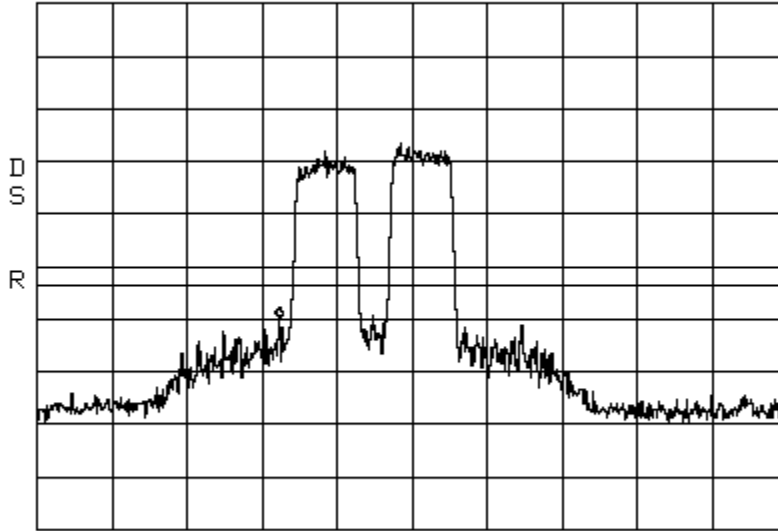

CENTER 751.50MHz SPAN 35.00MHz
*RBW 100kHz *VBW 100kHz SWP 50ms

Intermodulation

LTE 3MHz Channel Bandwidth_LowSpectrum 700 MHz Upper C

Path 1

Span: 30 MHz to 1 GHz

RBW/VBW: 300 kHz

ATTEN 10dB

MKR -30.17dBm

RL 40.5dBm

10dB/

650.8MHz

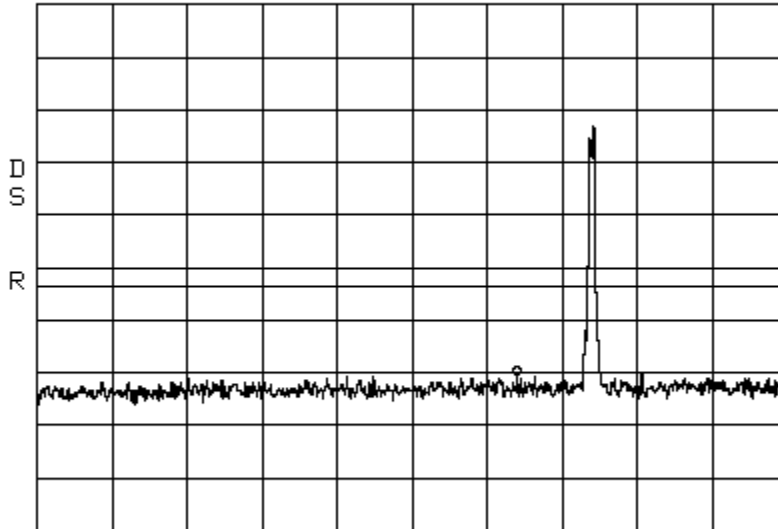

START 30.0MHz STOP 1.0000GHz
*RBW 300kHz *VBW 300kHz SWP 50ms

Intermodulation

LTE 3 MHz Channel Bandwidth _Low
Upper C Path 1

Spectrum 700 MHz

Span: 1 GHz to 10 GHz

RBW/VBW: 1 MHz

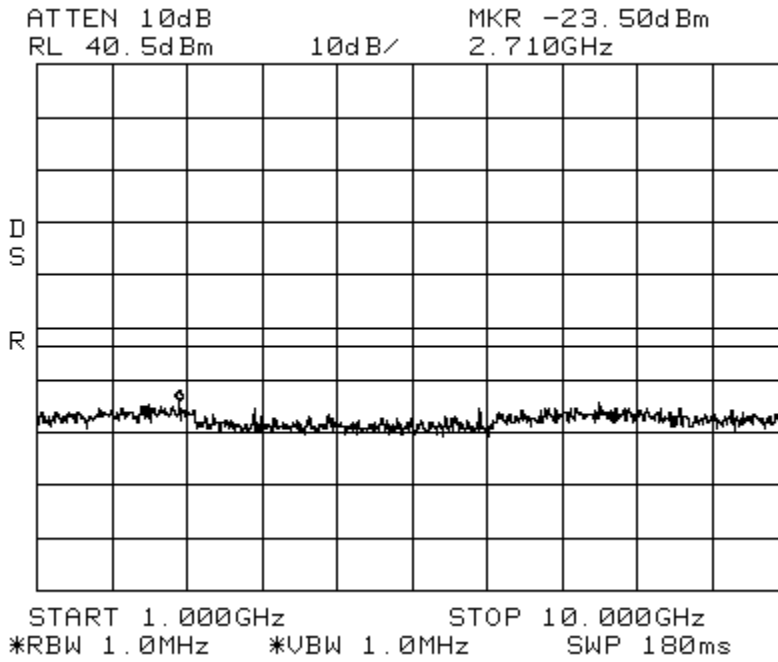

Intermodulation

LTE 3 MHz Channel Bandwidth _High
Upper C Path 1

Spectrum 700 MHz

Center: 751 MHz

Span: 35 MHz

RBW/VBW: 100 kHz

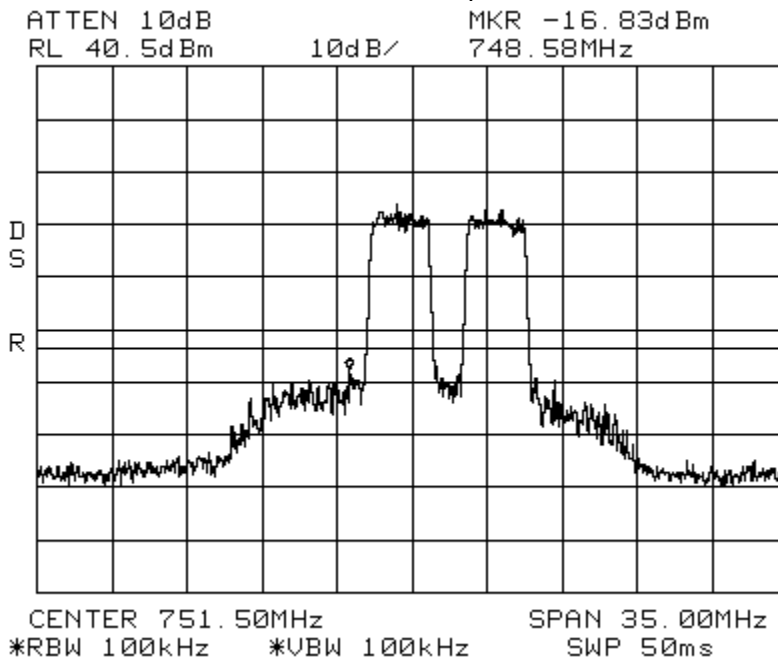

Intermodulation

LTE 3 MHz Channel Bandwidth _High
Upper C Path 1

Spectrum 700 MHz

Span: 30 MHz to 1 GHz

RBW/VBW: 300 kHz

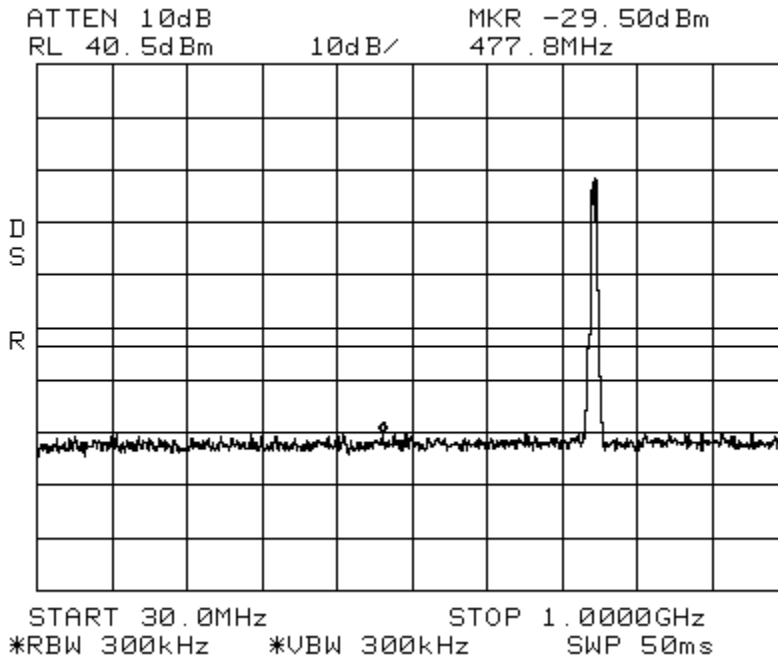

Intermodulation

LTE 3 MHz Channel Bandwidth _High
Upper C Path 1

Spectrum 700 MHz

Span: 1 GHz to 10 GHz

RBW/VBW: 1 MHz

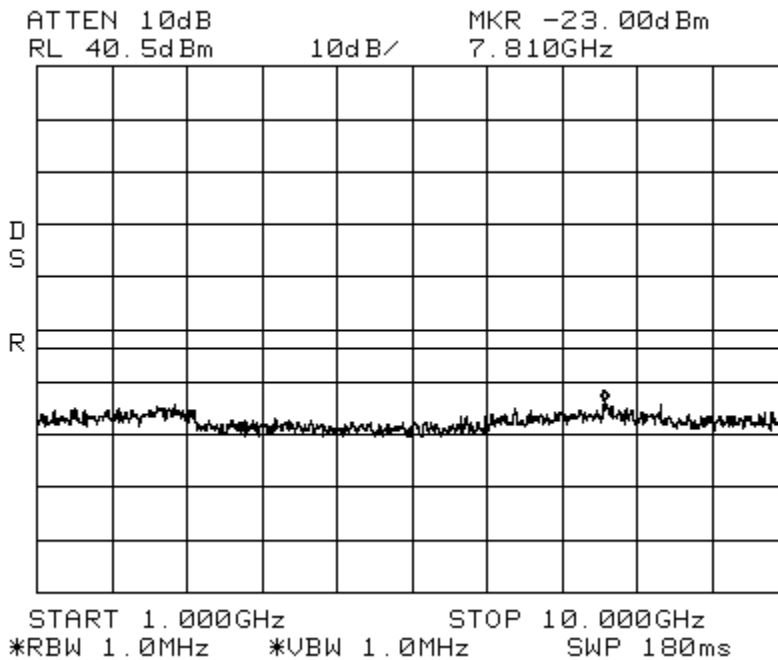

Intermodulation

LTE 3 MHz Channel Bandwidth _Apart

Spectrum 700 MHz

Upper C Path 1

Center: 751.5 MHz

Span: 70 MHz

RBW/VBW: 100 kHz

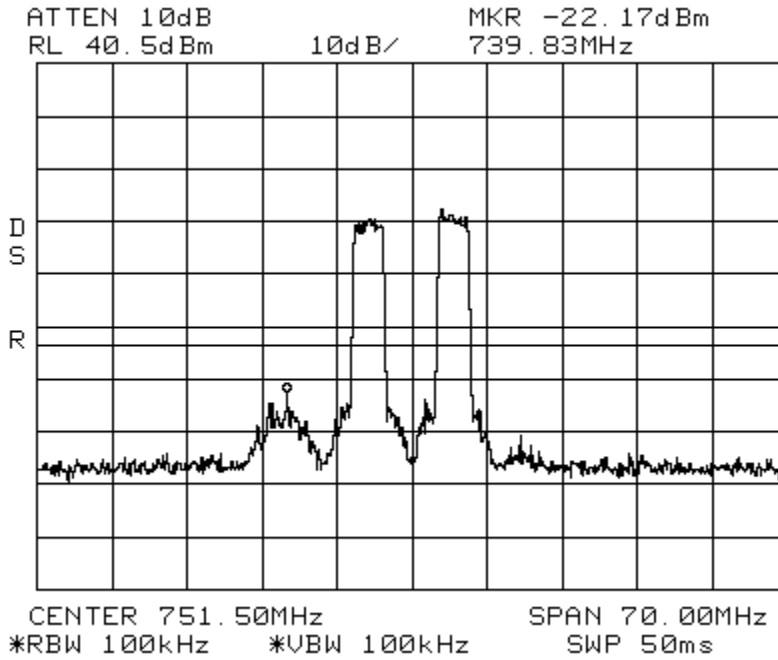

Intermodulation

LTE 3 MHz Channel Bandwidth _Apart

Spectrum 700 MHz

Upper C Path 1

Span: 30 MHz to 1 GHz

RBW/VBW: 300 kHz

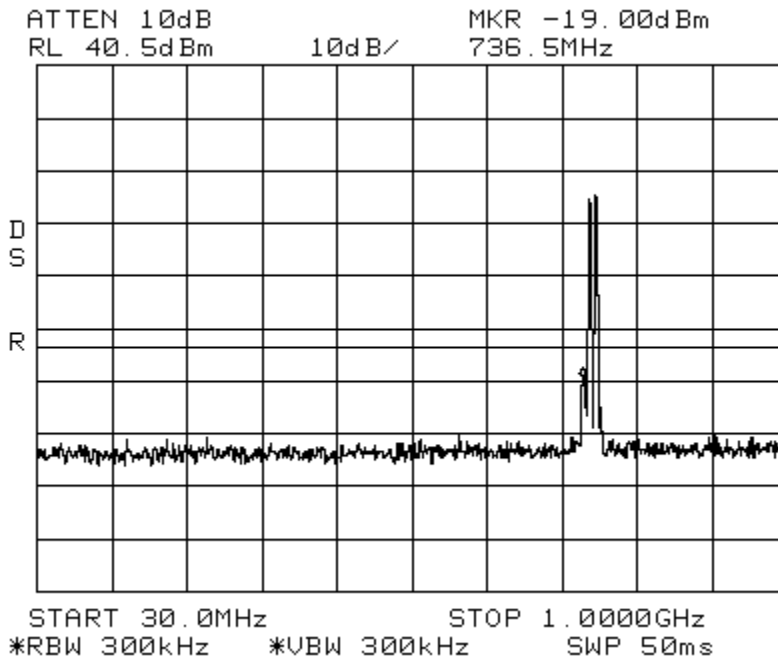

Intermodulation

LTE 5 MHz Channel Bandwidth
Path 1

Spectrum 700 MHz Upper C

Span: 30 MHz to 1 GHz

RBW/VBW: 300 kHz

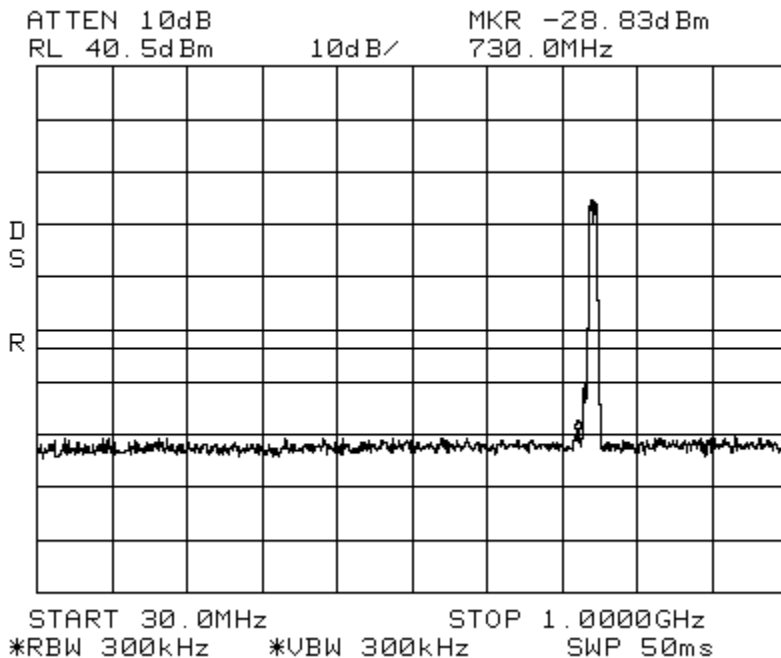

Intermodulation

LTE 5 MHz Channel Bandwidth
Path 1

Spectrum 700 MHz Upper C

Span: 1 GHz to 10 GHz

RBW/VBW: 1 MHz

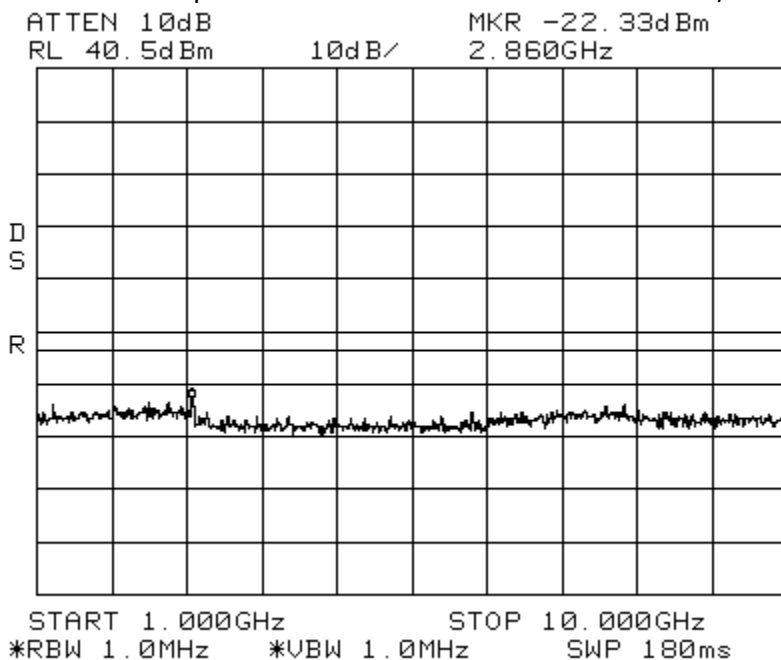

Intermodulation
Center: 2132.5 MHz

WCDMA_Low
Span: 70 MHz

Spectrum AWS Path 1
RBW/VBW: 100 kHz

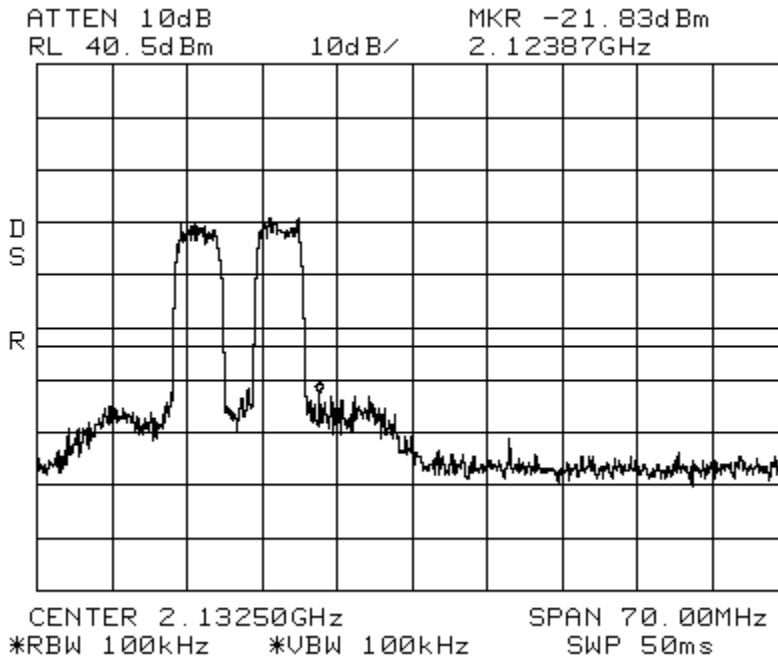

Intermodulation
Span: 30 MHz to 1 GHz

WCDMA_Low

Spectrum AWS Path 1
RBW/VBW: 300 kHz

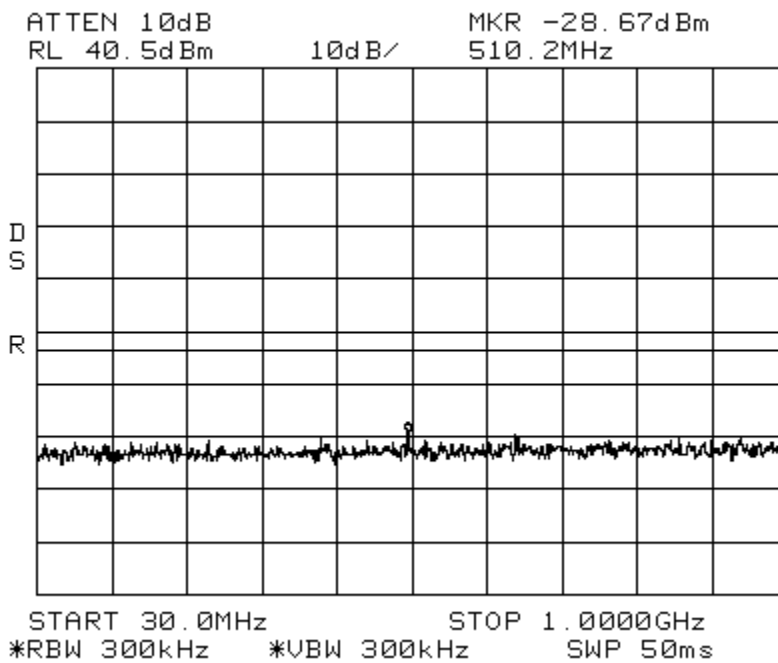

Intermodulation WCDMA_Low Spectrum AWS Path 1
Span: 1 GHz to 22 GHz RBW/VBW: 1 MHz

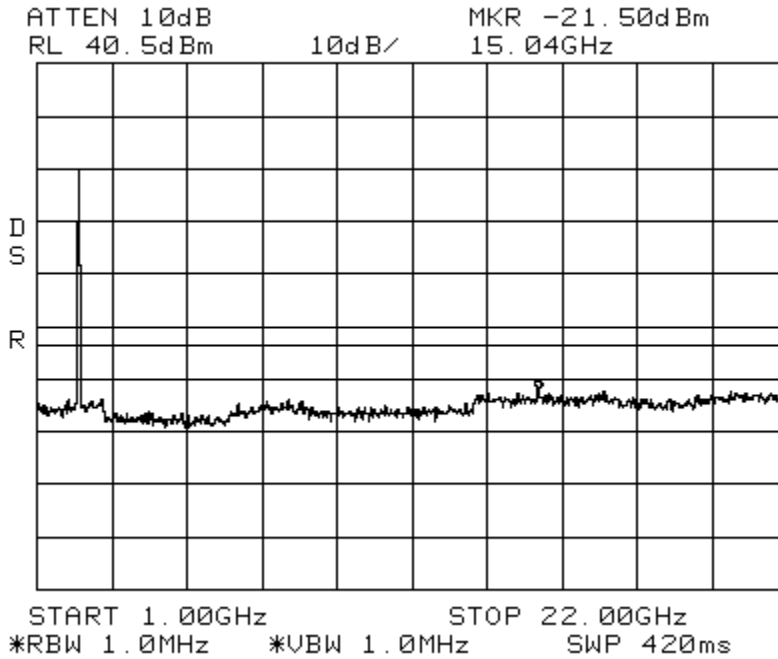

Intermodulation WCDMA_High Spectrum AWS Path 1
Center: 2132.5 MHz Span: 70 MHz RBW/VBW: 100 kHz

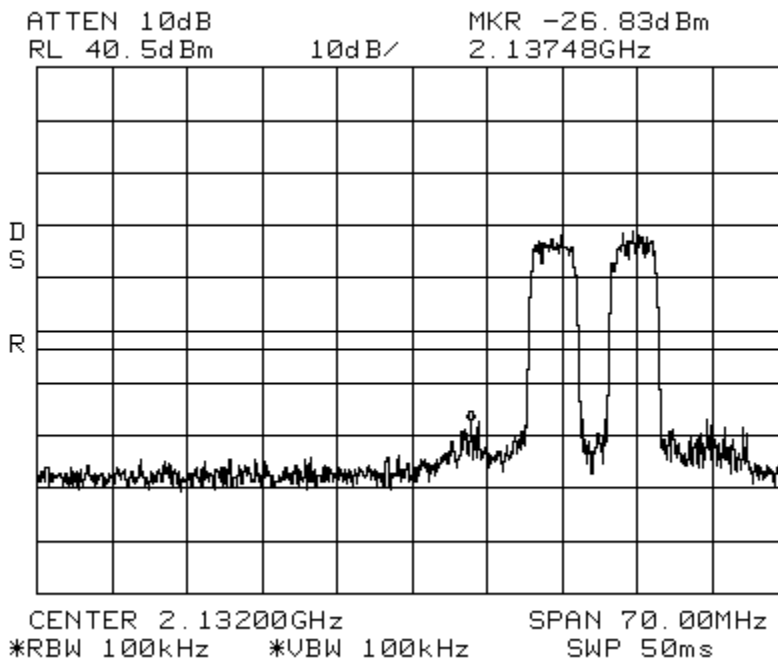

Intermodulation WCDMA_High Spectrum AWS Path 1
Span: 30 MHz to 1 GHz RBW/VBW: 300 kHz

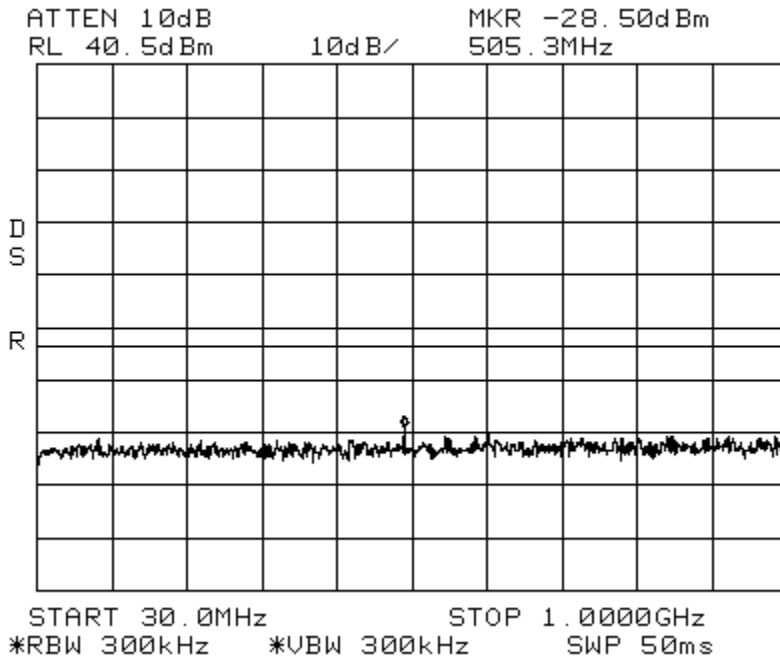

Intermodulation WCDMA_High Spectrum AWS Path 1
Span: 1 GHz to 22 GHz RBW/VBW: 1 MHz

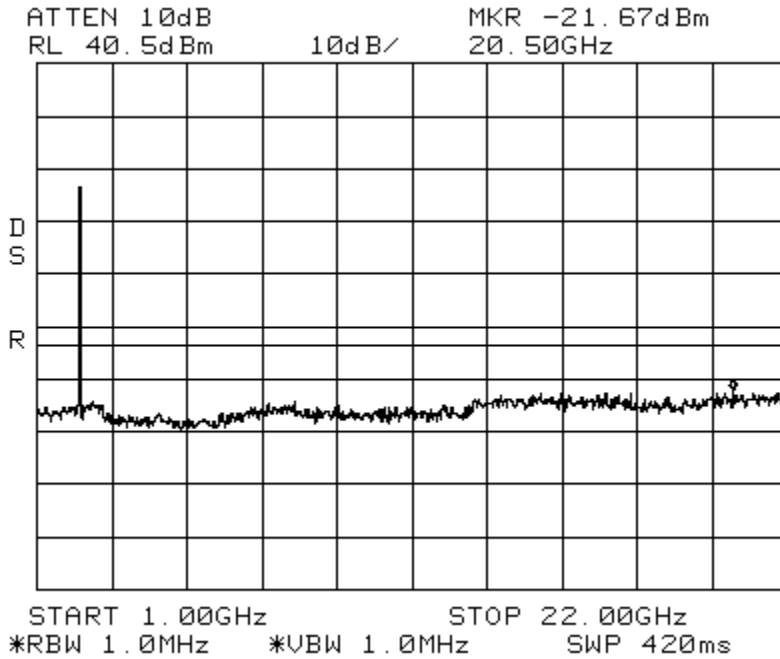

Intermodulation
Center: 2132.5 MHz
ATTEN 10dB
RL 40.5dBm

WCDMA_Apart
Span: 175 MHz
MKR -29.67dBm
2.1932GHz

Spectrum AWS Path 1
RBW/VBW: 100 kHz

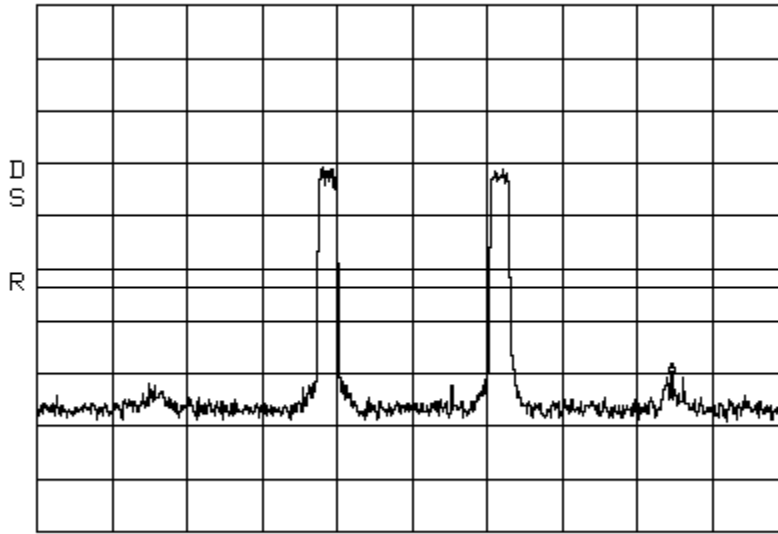

CENTER 2.1325GHz SPAN 175.0MHz
*RBW 100kHz *VBW 100kHz SWP 50ms

Intermodulation

WCDMA_Apart

Spectrum AWS Path 1

Span: 30 MHz to 1 GHz

RBW/VBW: 300 kHz

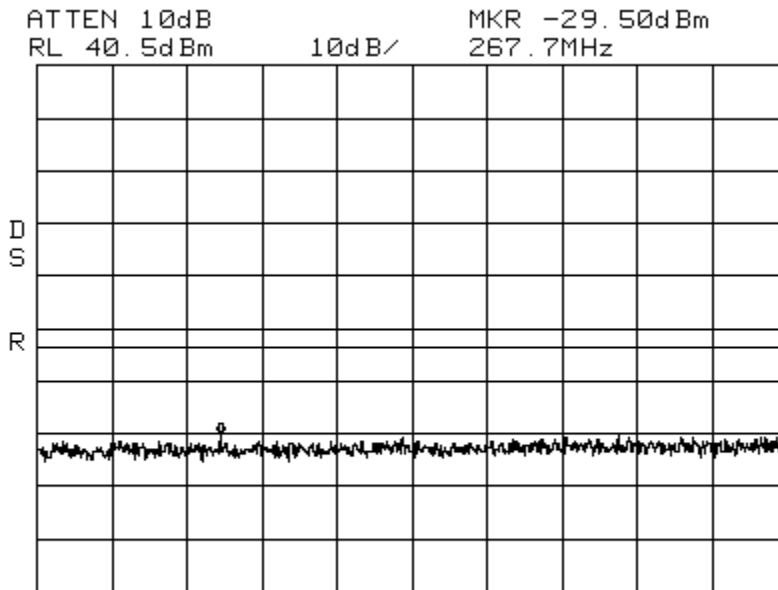

START 30.0MHz STOP 1.0000GHz
*RBW 300kHz *VBW 300kHz SWP 50ms

Intermodulation WCDMA_Apart Spectrum AWS Path 1
 Span: 1 GHz to 22 GHz RBW/VBW: 1 MHz
 ATTN 10dB MKR -21.50dBm
 RL 40.5dBm 10dB/ 20.25GHz

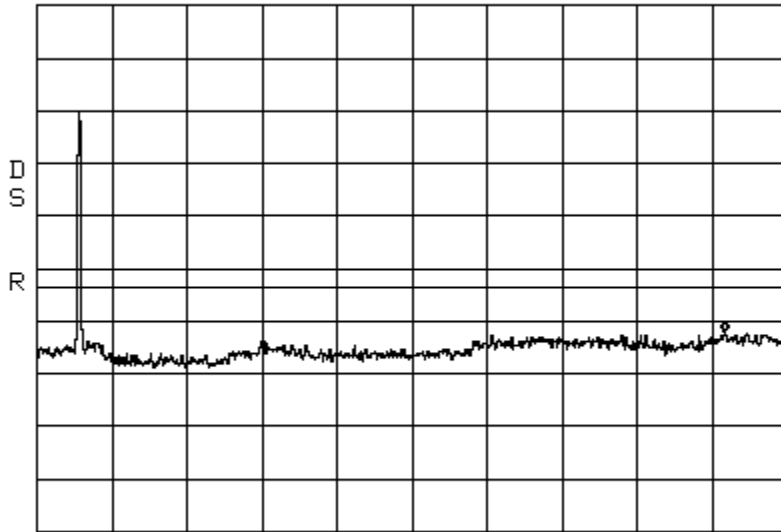

START 1.00GHz STOP 22.00GHz
 *RBW 1.0MHz *VBW 1.0MHz SWP 420ms

Intermodulation LTE 3 MHz Channel Bandwidth_Low AWS Path 1
 Center: 2132.5 MHz Span: 90 MHz RBW/VBW: 100 kHz

ATTN 10dB MKR -20.67dBm
 RL 40.5dBm 10dB/ 2.10610GHz

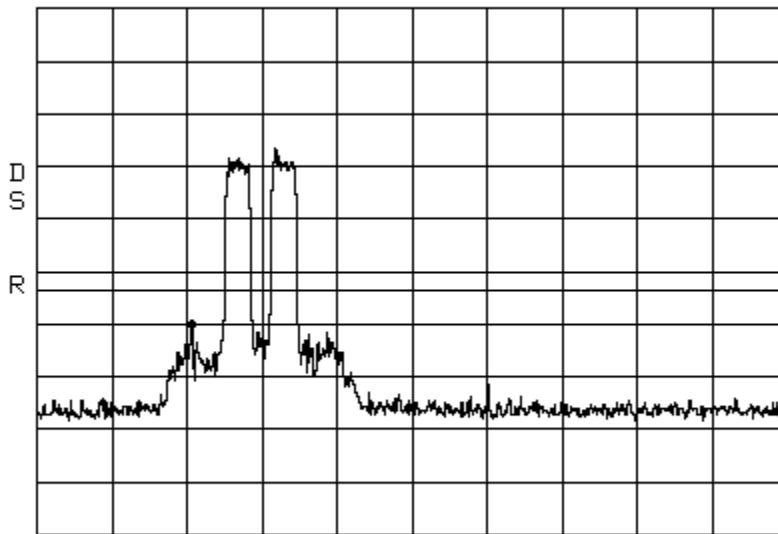

CENTER 2.13250GHz SPAN 90.00MHz
 *RBW 100kHz *VBW 100kHz SWP 50ms

Intermodulation LTE 3MHz Channel Bandwidth _LowAWS Path 1
Span: 30 MHz to 1 GHz RBW/VBW: 300 kHz

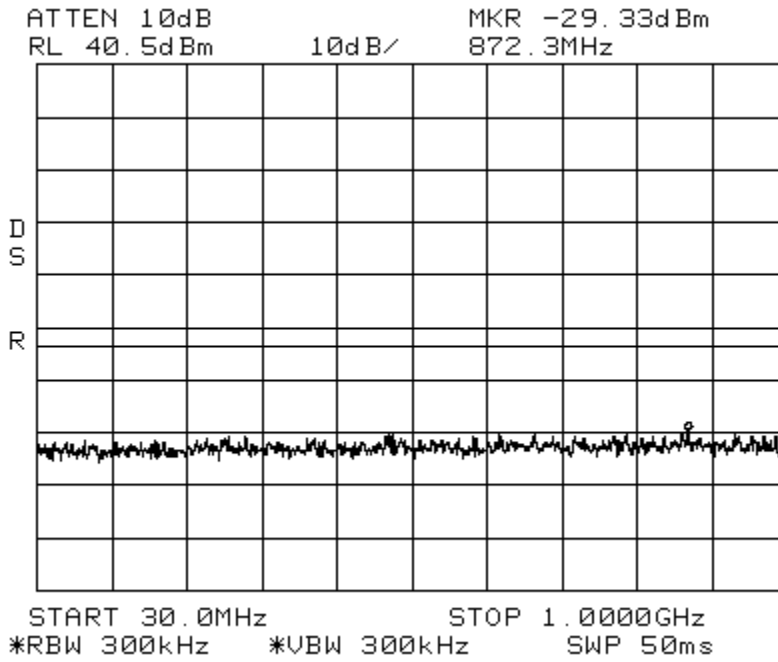

Intermodulation LTE 3 MHz Channel Bandwidth _Low AWS Path 1
Span: 1 GHz to 20 GHz RBW/VBW: 1 MHz

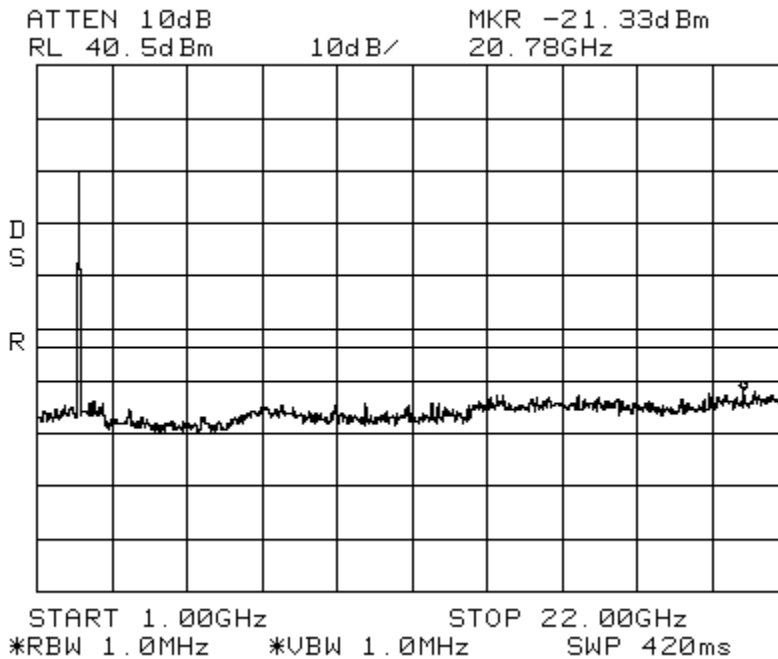

Intermodulation LTE 3 MHz Channel Bandwidth_High AWS Path 1
Center: 2132.5 MHz Span: 90 MHz RBW/VBW: 100 kHz

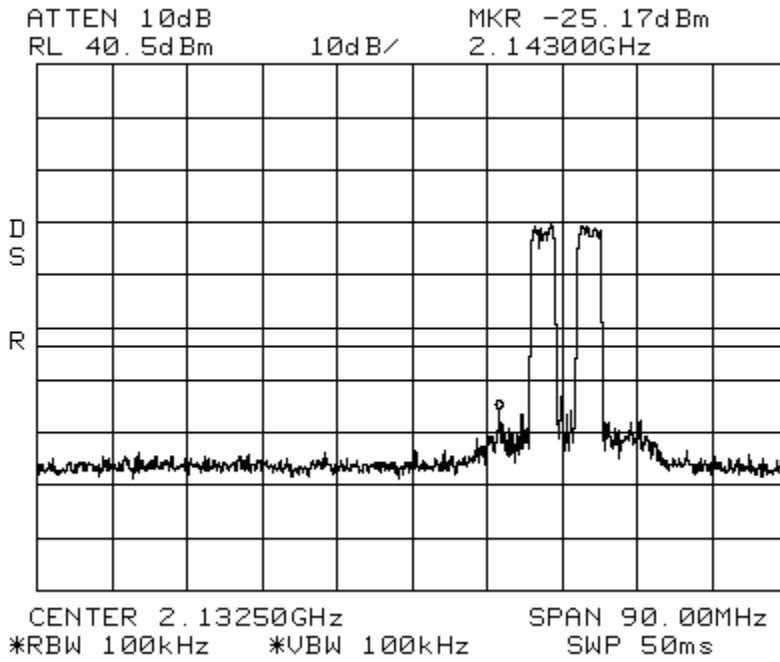

Intermodulation LTE 3 MHz Channel Bandwidth_High AWS Path 1
Span: 30 MHz to 1 GHz RBW/VBW: 300 kHz

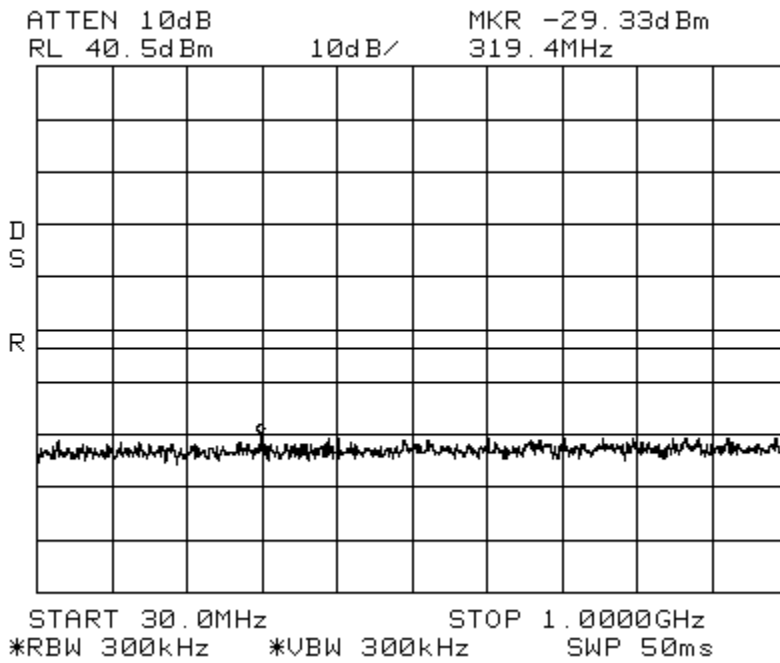

Intermodulation LTE 3 MHz Channel Bandwidth_High AWS Path 1
Span: 1 GHz to 20 GHz RBW/VBW: 1 MHz

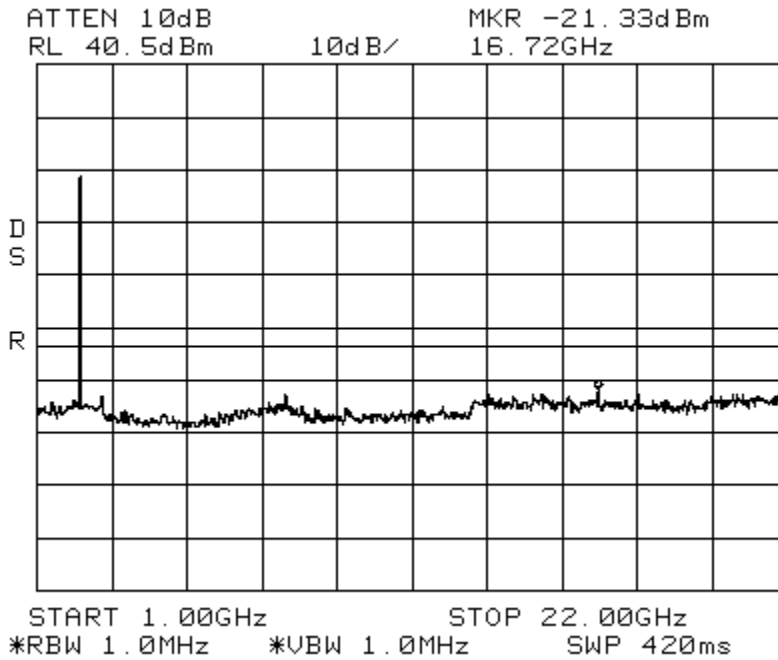

Intermodulation LTE 3 MHz Channel Bandwidth_Apart AWS Path 1
Center: 2132.5 MHz Span: 175 MHz RBW/VBW: 100 kHz

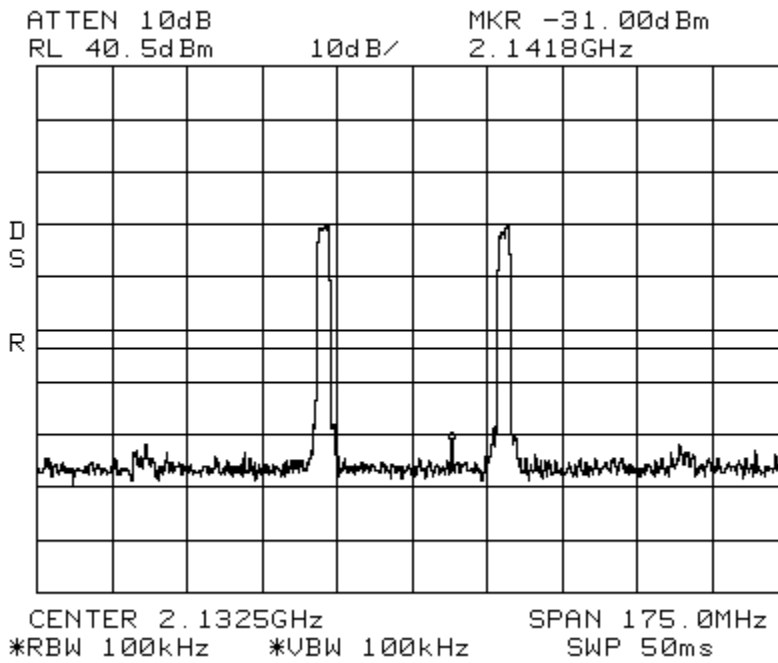

Intermodulation LTE 3 MHz Channel Bandwidth _Apart AWS Path 1
Span: 30 MHz to 1 GHz RBW/VBW: 300 kHz

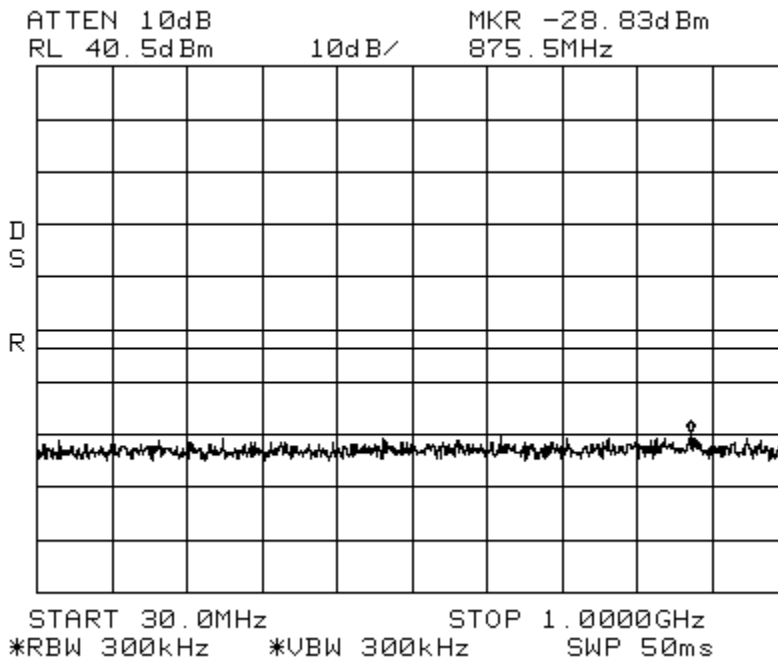

Intermodulation LTE 3 MHz Channel Bandwidth _Apart AWS Path 1
Span: 1 GHz to 20 GHz RBW/VBW: 1 MHz

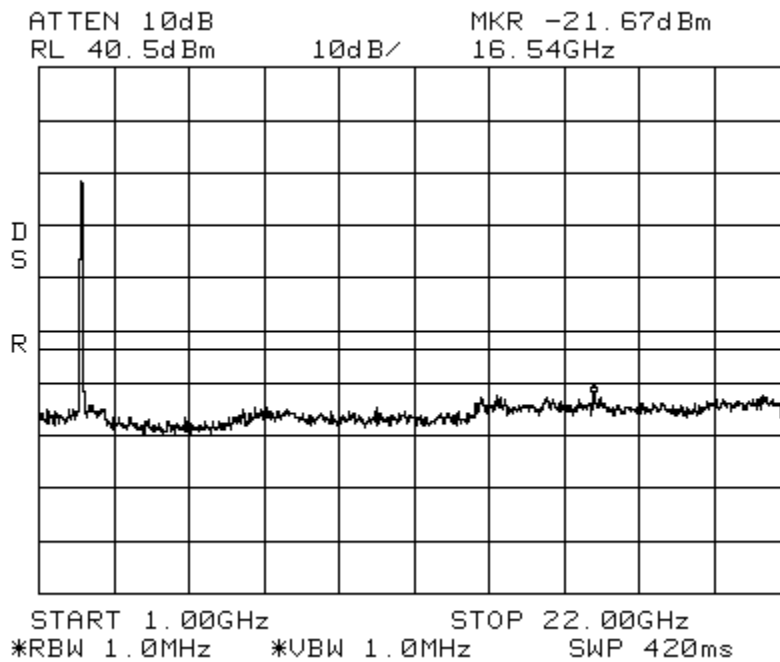

Intermodulation LTE 5 MHz Channel Bandwidth_Low AWS Path 1
Center: 2132.5 MHz Span: 90 MHz RBW/VBW: 100 kHz

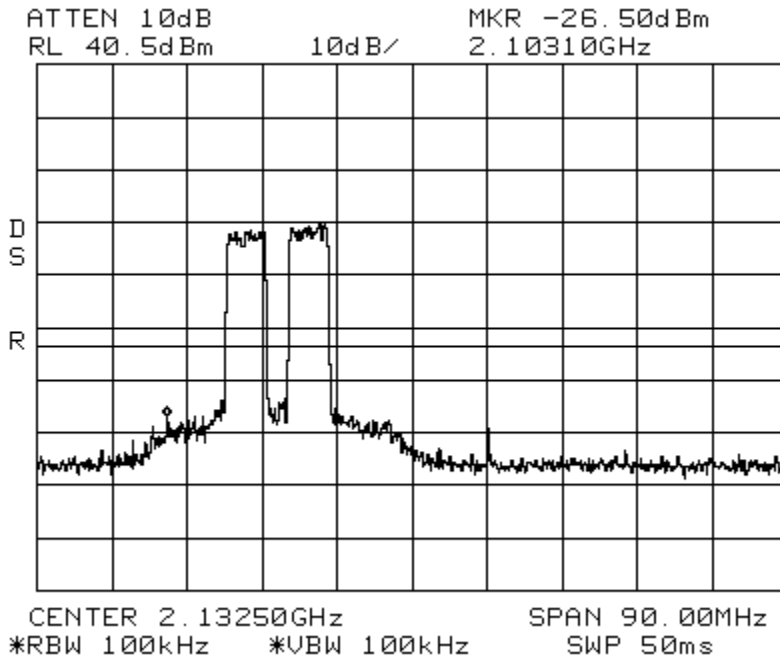

Intermodulation LTE 5 MHz Channel Bandwidth_Low AWS Path 1
Span: 30 MHz to 1 GHz RBW/VBW: 300 kHz

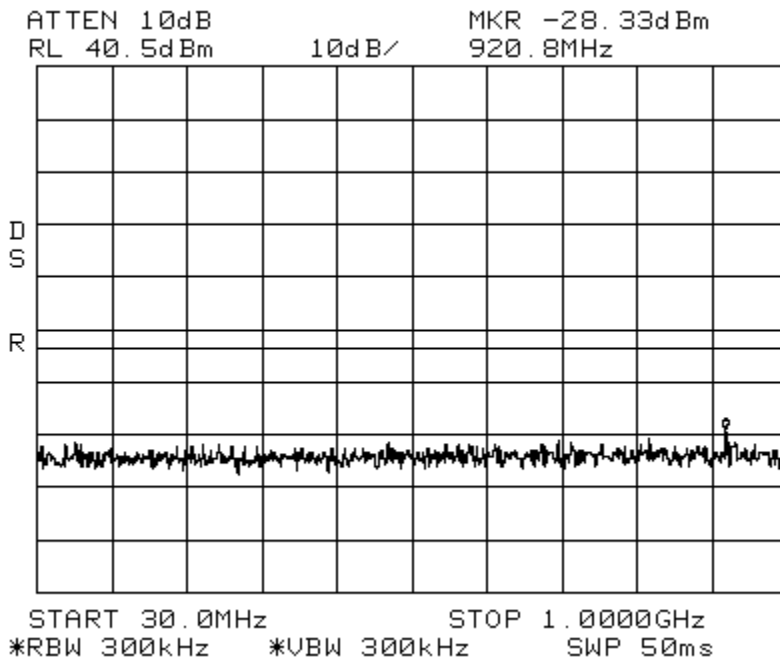

Intermodulation LTE 5 MHz Channel Bandwidth _Low AWS Path 1
Span: 1 GHz to 22 GHz RBW/VBW: 1 MHz

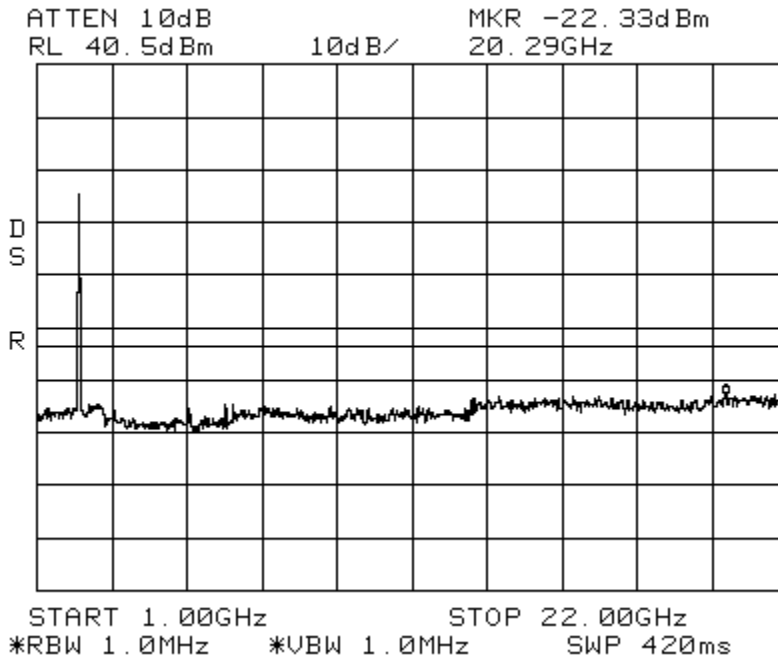

Intermodulation LTE 5 MHz Channel Bandwidth _High AWS Path 1
Center: 2132.5 MHz Span: 90 MHz RBW/VBW: 100 kHz

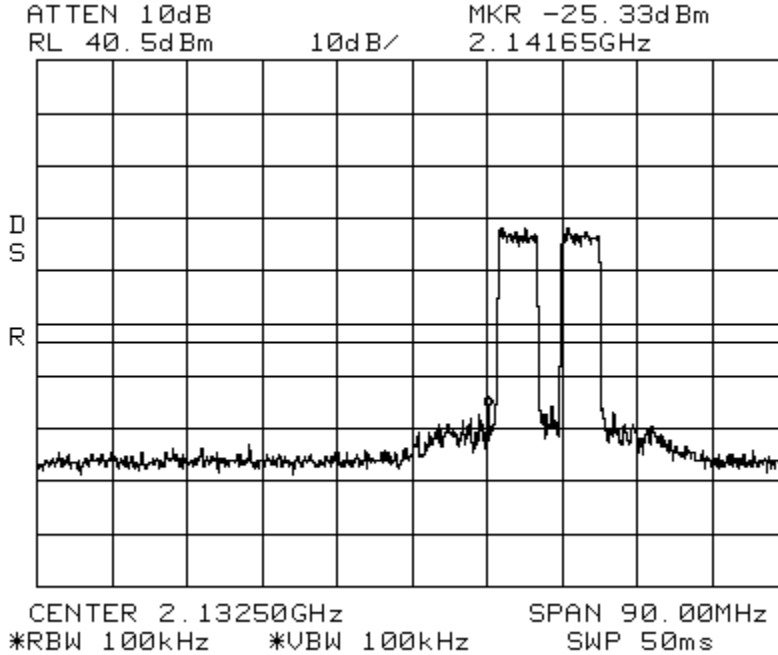

Intermodulation LTE 5 MHz Channel Bandwidth_High AWS Path 1
Span: 30 MHz to 1 GHz RBW/VBW: 300 kHz

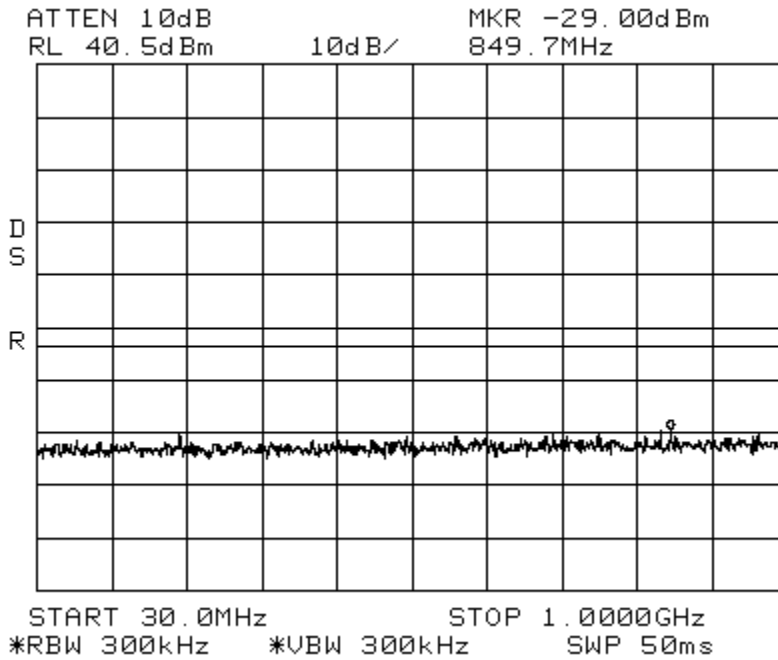

Intermodulation LTE 5 MHz Channel Bandwidth_High AWS Path 1
Span: 1 GHz to 22 GHz RBW/VBW: 1 MHz

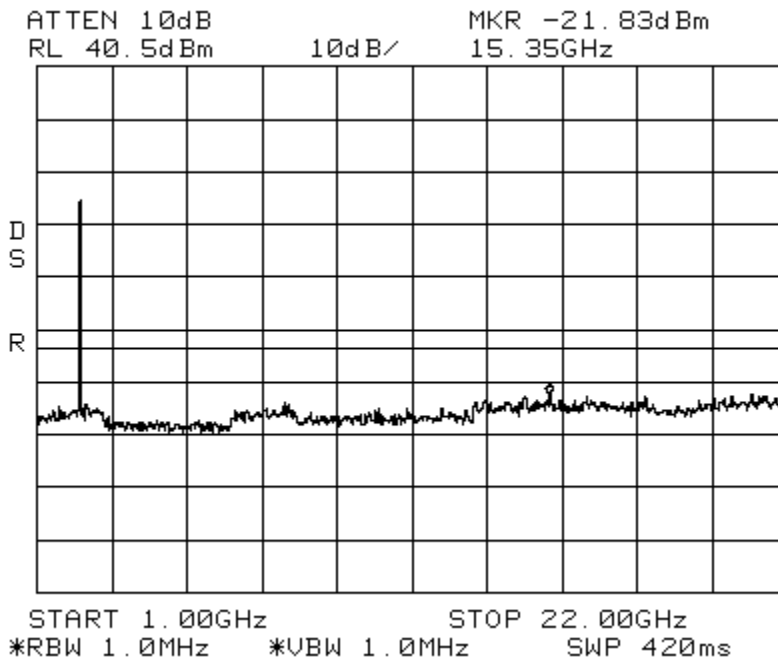

Intermodulation LTE 5 MHz Channel Bandwidth _Apart AWS Path 1
Center: 2132.5 MHz Span: 175 MHz RBW/VBW: 100 kHz

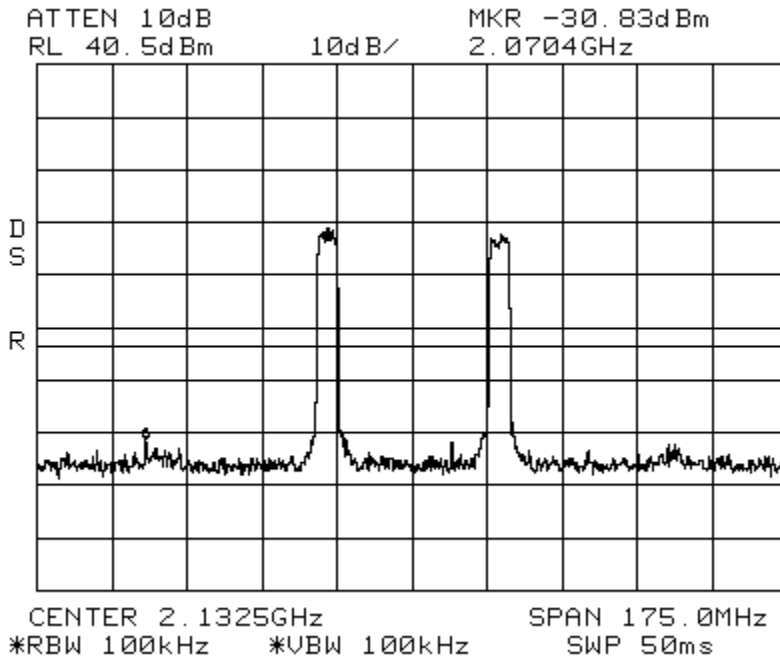

Intermodulation LTE 5 MHz Channel Bandwidth _Apart AWS Path 1
Span: 30 MHz to 1 GHz RBW/VBW: 300 kHz

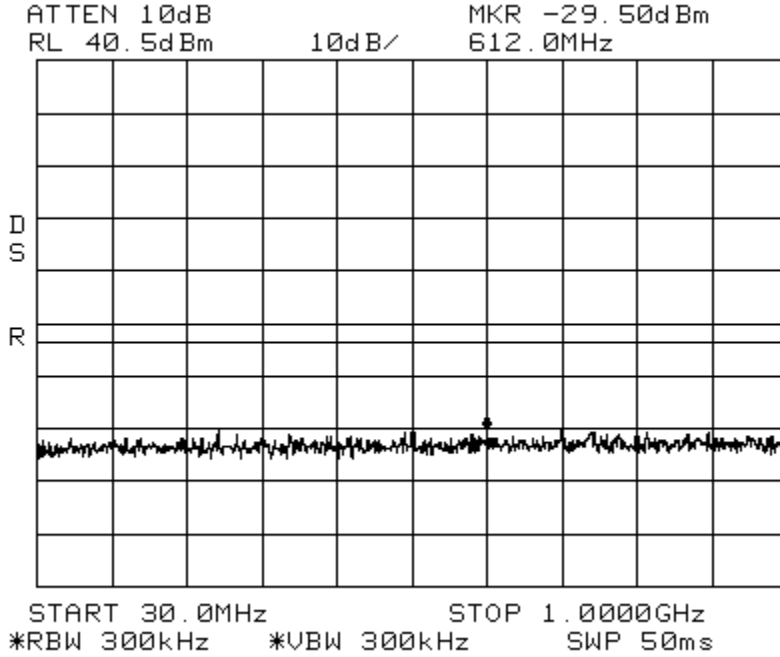

Intermodulation LTE 5 MHz Channel Bandwidth_Apart AWS Path 1
Span: 1 GHz to 22 GHz RBW/VBW: 1 MHz

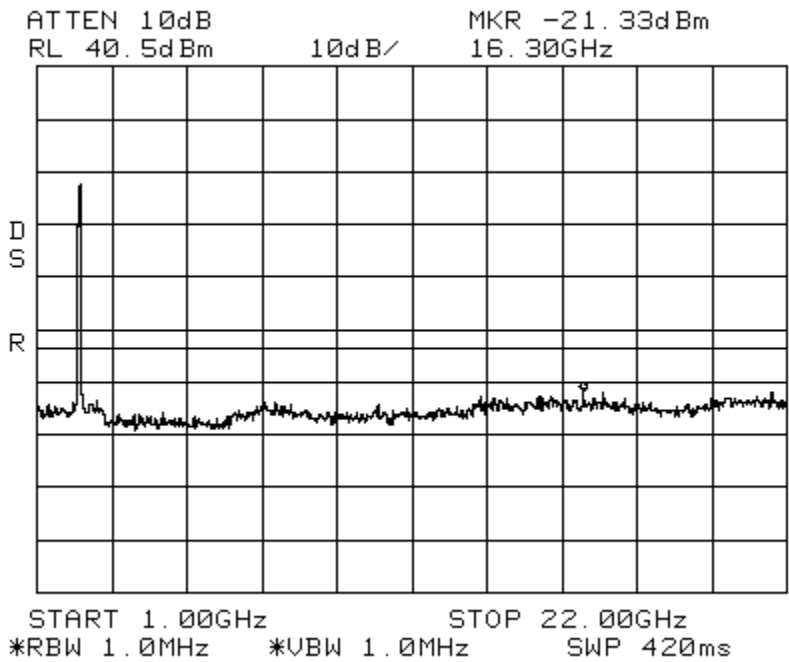

Intermodulation LTE 10 MHz Channel Bandwidth_Low AWS Path 1
Center: 2132.5 MHz Span: 90 MHz RBW/VBW: 100 kHz

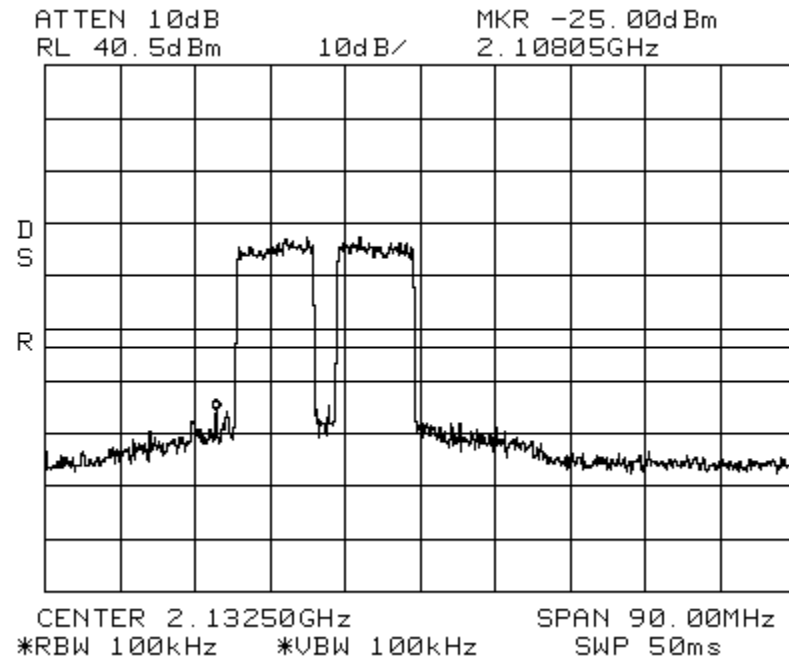

Intermodulation LTE 10 MHz Channel Bandwidth_Low AWS Path 1
Span: 30 MHz to 1 GHz RBW/VBW: 300 kHz

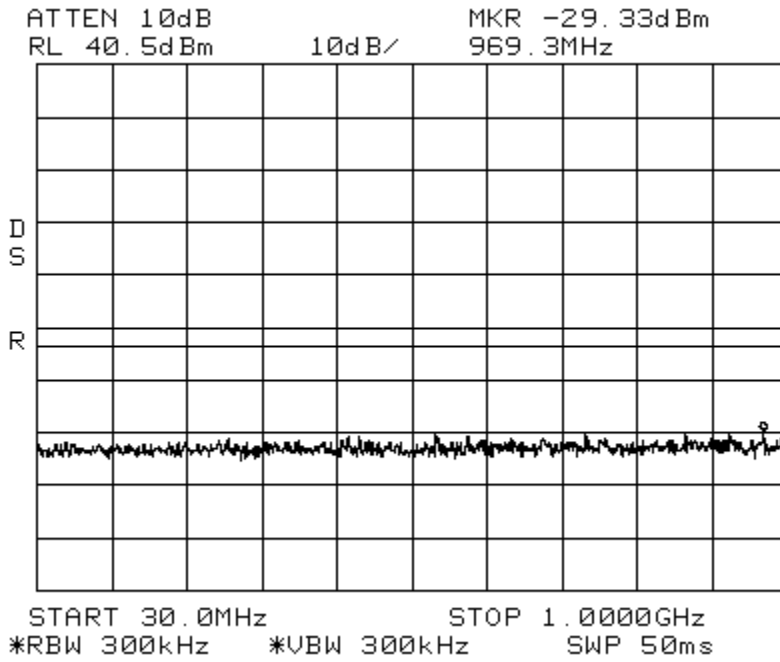

Intermodulation LTE 10 MHz Channel Bandwidth_Low AWS Path 1
Span: 1 GHz to 22GHz RBW/VBW: 1 MHz

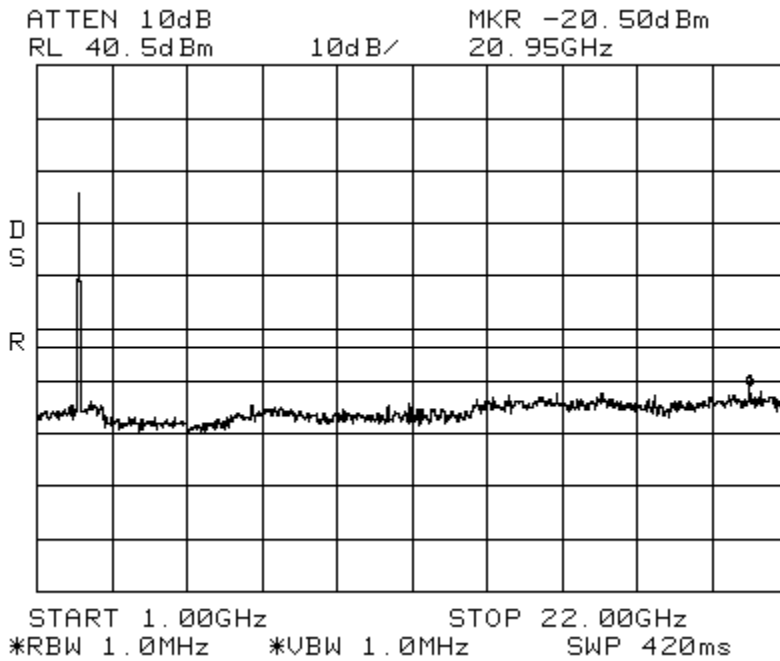

Intermodulation LTE 10 MHz Channel Bandwidth_High AWS Path 1
Center: 2132.5 MHz Span: 90 MHz RBW/VBW: 100 kHz

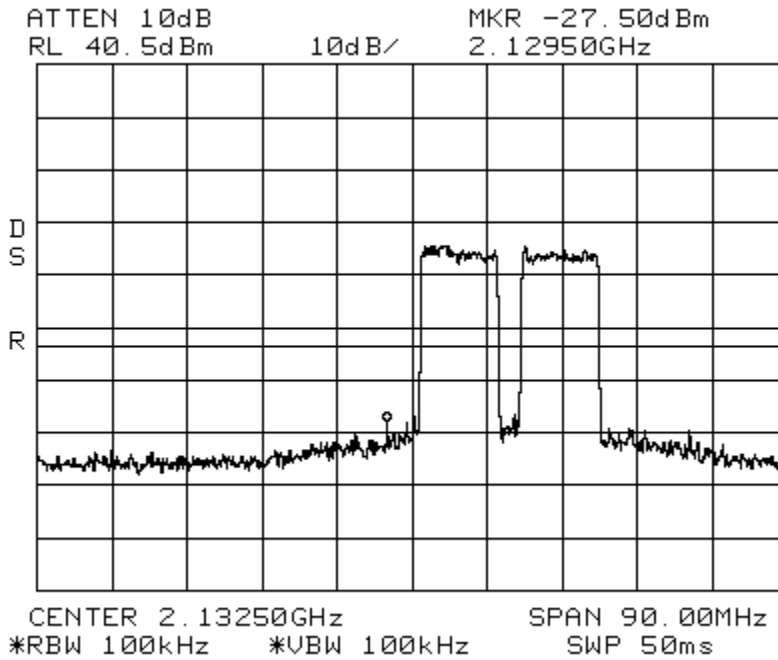

Intermodulation LTE 10 MHz Channel Bandwidth_High AWS Path 1
Span: 30 MHz to 1 GHz RBW/VBW: 300 kHz

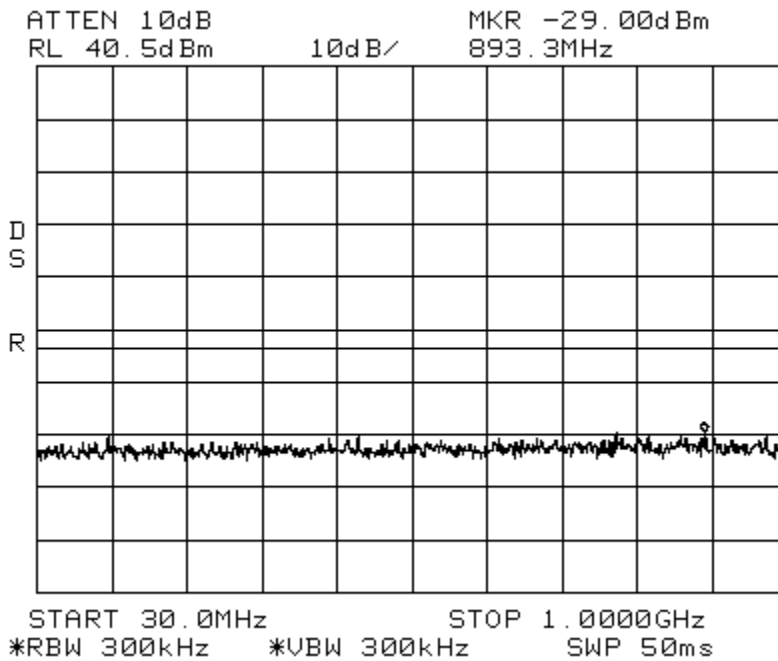

Intermodulation LTE 10 MHz Channel Bandwidth_High AWS Path 1
Span: 1 GHz to 22 GHz RBW/VBW: 1 MHz

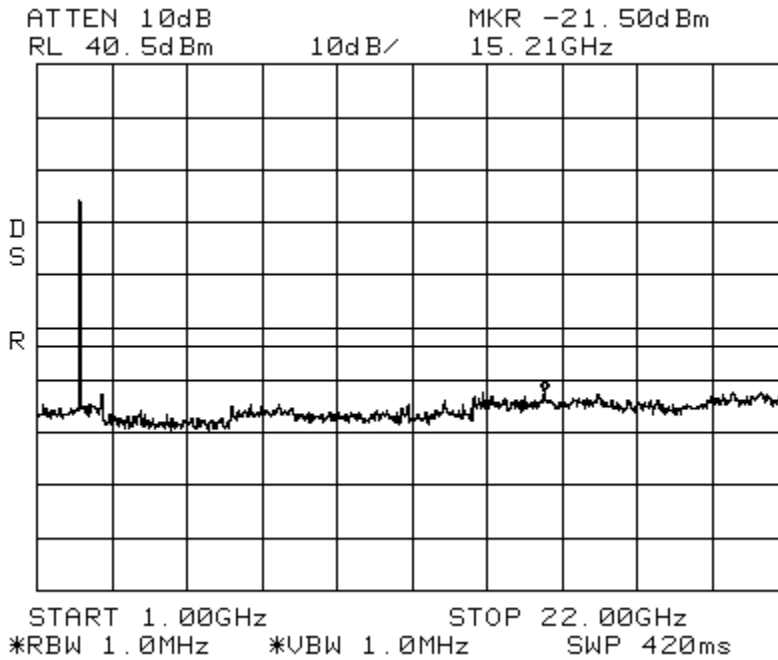

Intermodulation LTE 10 MHz Channel Bandwidth_Apart AWS Path 1
Center: 2132.5 MHz Span: 175 MHz RBW/VBW: 100 kHz

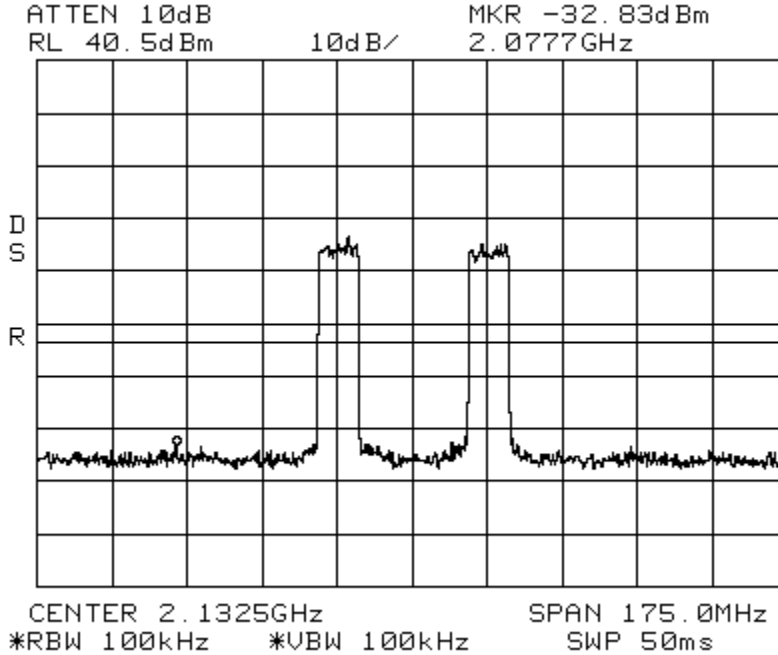

Intermodulation LTE 10 MHz Channel Bandwidth_Apart AWS Path 1
Span: 30 MHz to 1 GHz RBW/VBW: 300 kHz

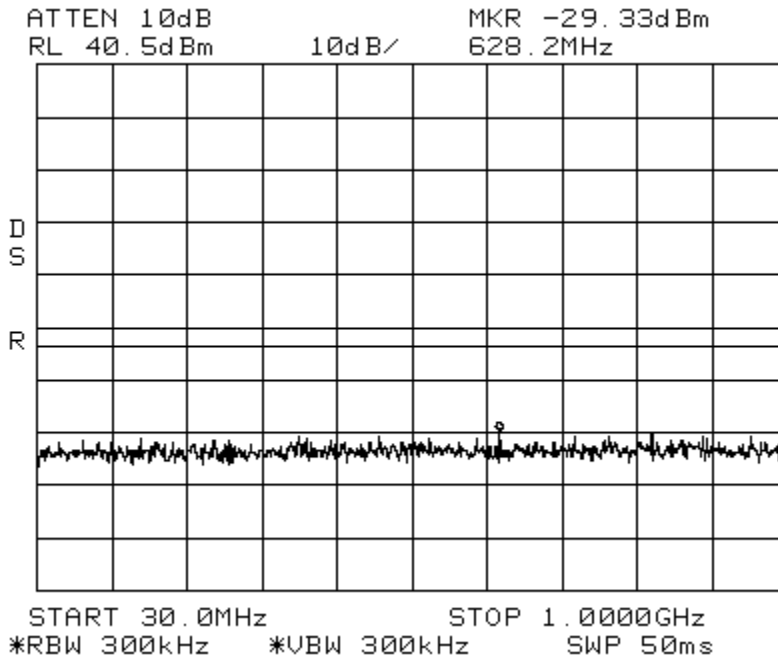

Intermodulation LTE 10 MHz Channel Bandwidth_Apart AWS Path 1
Span: 1 GHz to 22 GHz RBW/VBW: 1 MHz

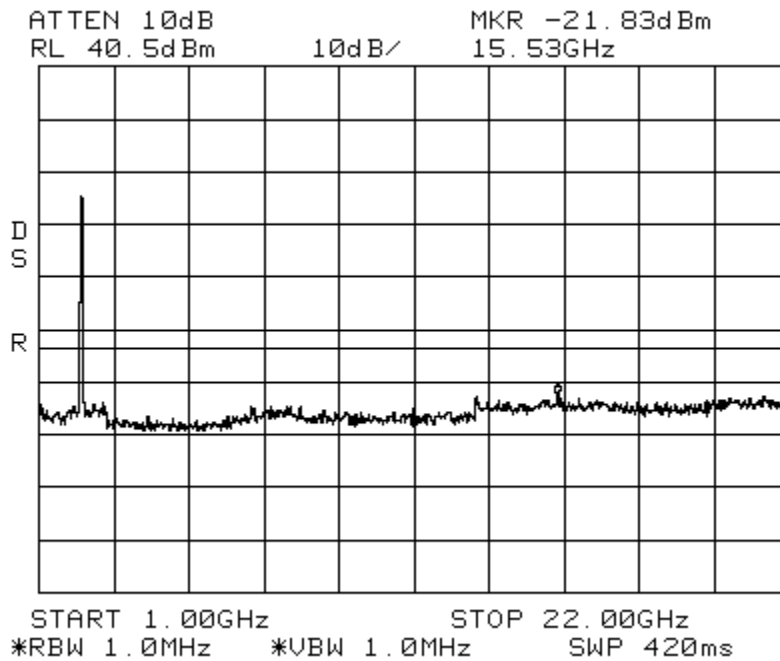

Intermodulation LTE 15 MHz Channel Bandwidth **Low** AWS Path 1
Center: 2132.5 MHz Span: 90 MHz RBW/VBW: 100 kHz

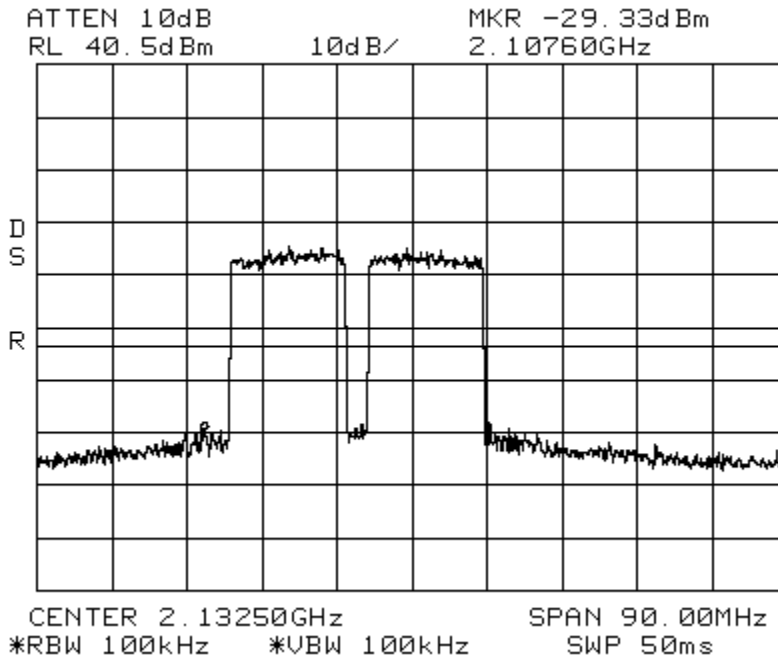

Intermodulation LTE 15 MHz Channel Bandwidth **Low** AWS Path 1
Span: 30 MHz to 1 GHz RBW/VBW: 300 kHz

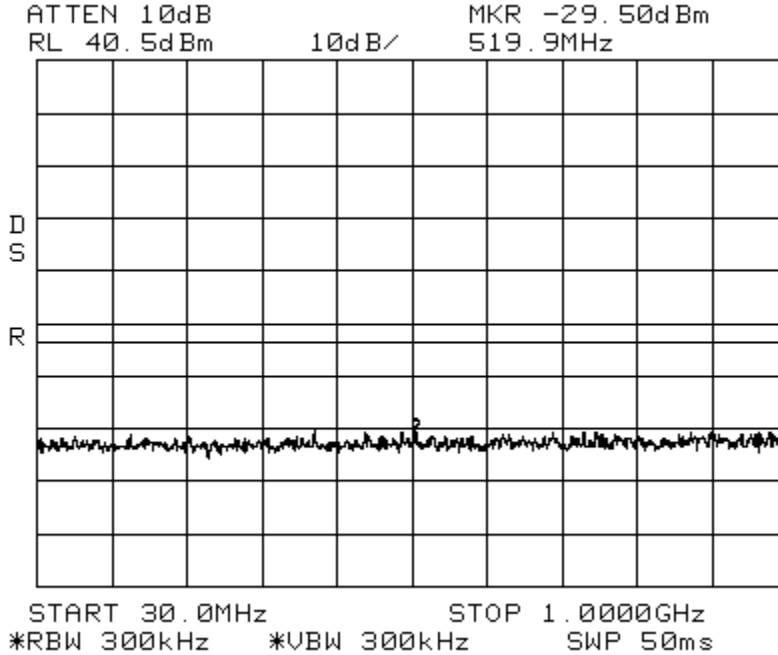

Intermodulation LTE 15 MHz Channel Bandwidth_Low AWS Path 1
Span: 1 GHz to 22 GHz RBW/VBW: 1 MHz

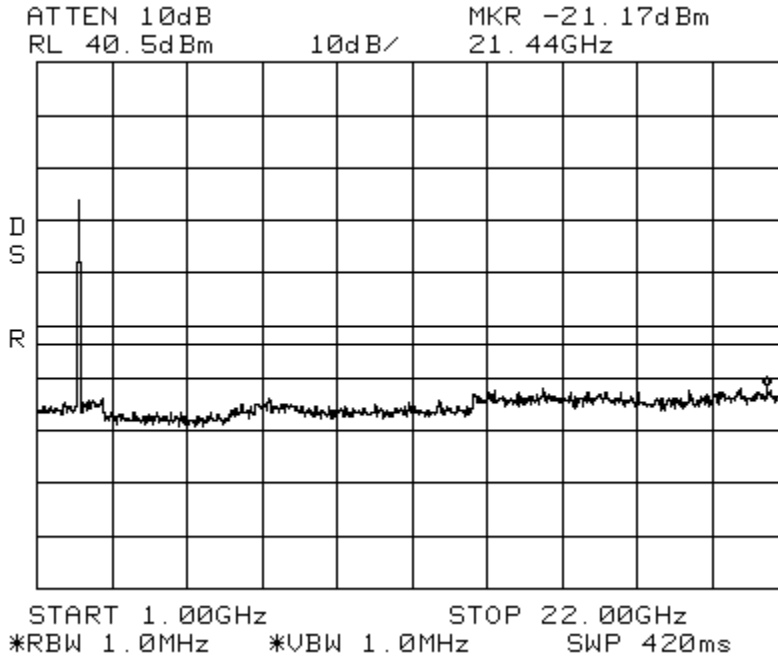

Intermodulation LTE 15 MHz Channel Bandwidth_High AWS Path 1
Center: 2132.5 MHz Span: 90 MHz RBW/VBW: 100 kHz

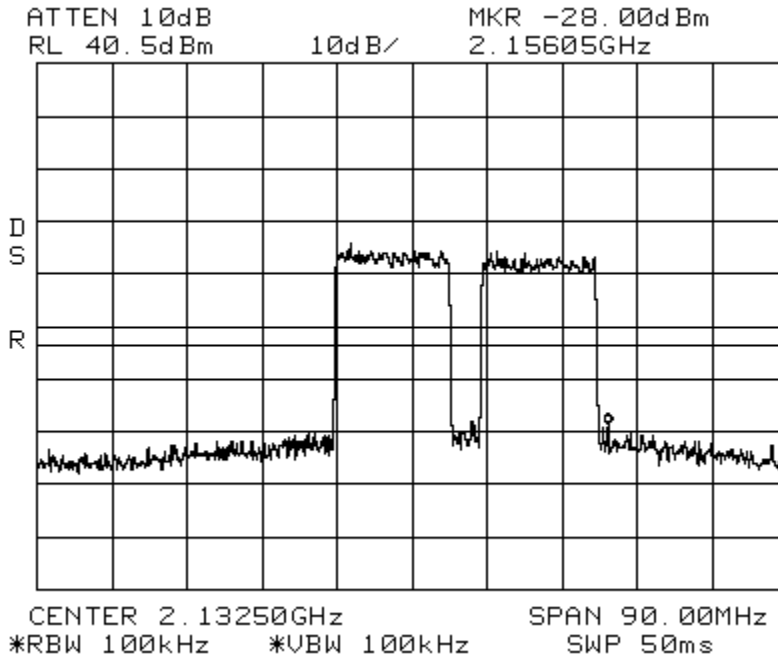

Intermodulation LTE 15 MHz Channel Bandwidth_High AWS Path 1
Span: 30 MHz to 1 GHz RBW/VBW: 300 kHz

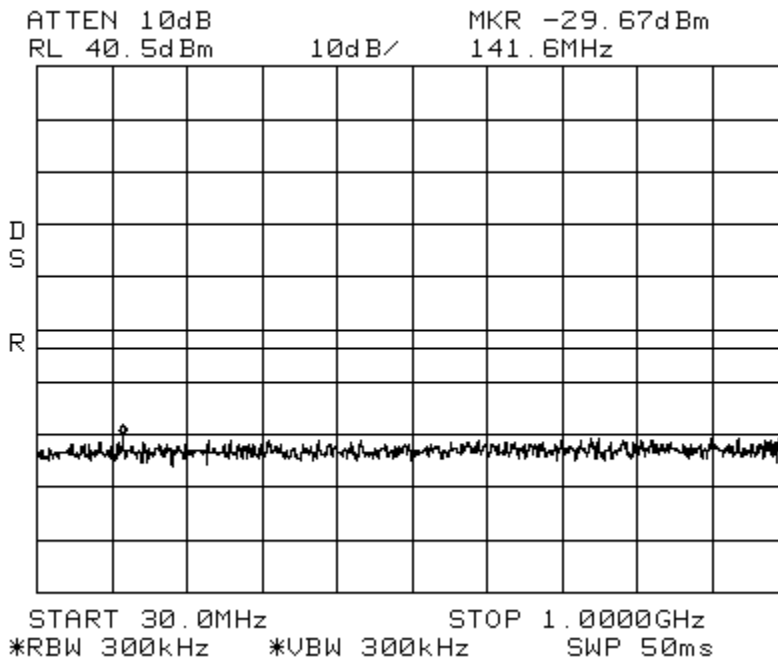

Intermodulation LTE 15 MHz Channel Bandwidth_High AWS Path 1
Span: 1 GHz to 22 GHz RBW/VBW: 1 MHz

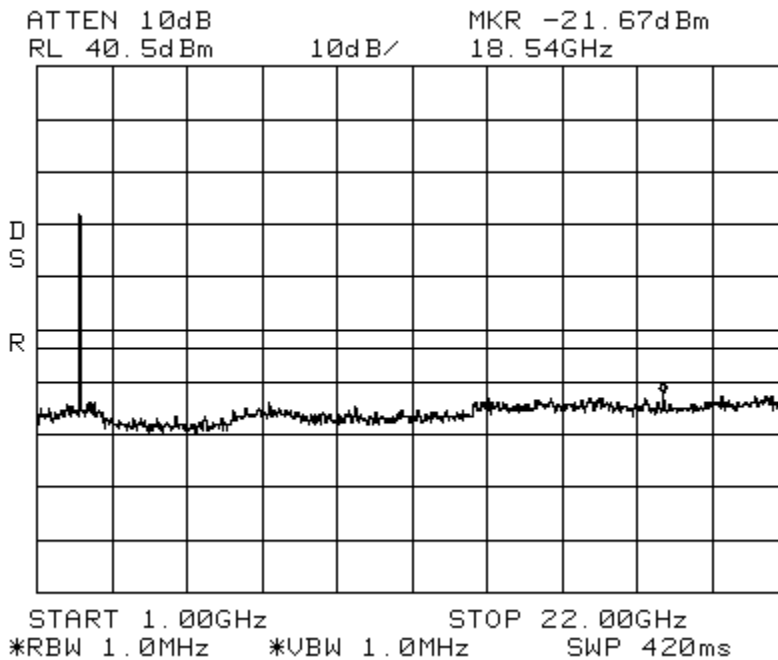

Intermodulation LTE 15 MHz Channel Bandwidth _Apart AWS Path 1
Center: 2132.5 MHz Span: 90 MHz RBW/VBW: 100 kHz

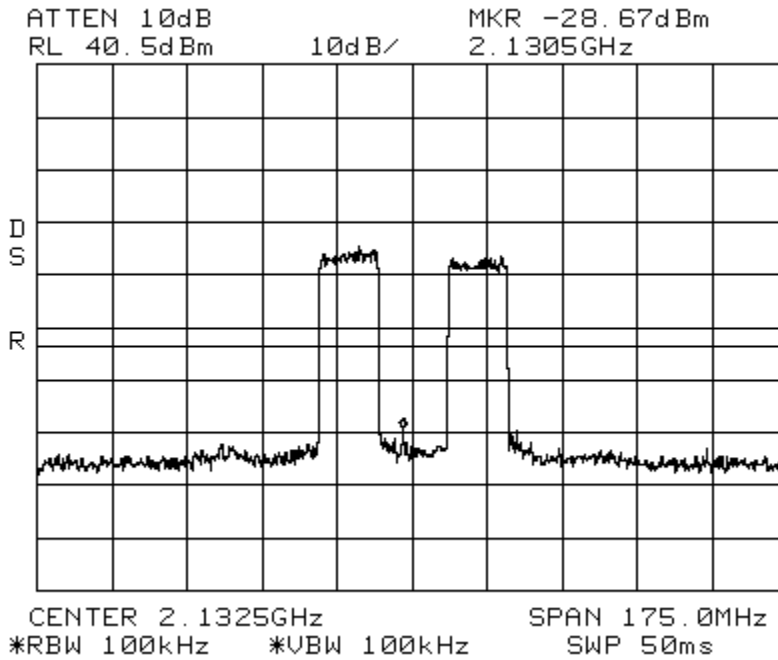

Intermodulation LTE 15 MHz Channel Bandwidth _Apart AWS Path 1
Span: 30 MHz to 1 GHz RBW/VBW: 300 kHz

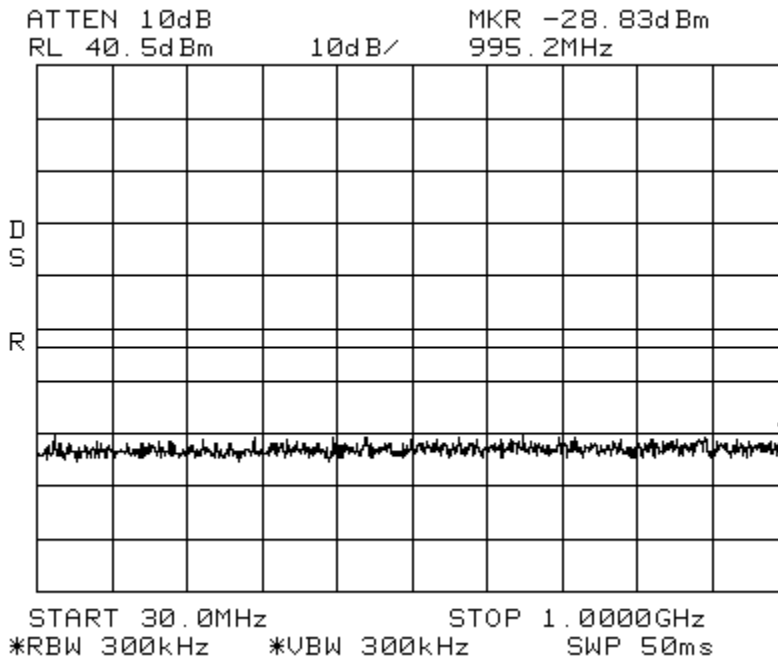

Intermodulation LTE 15 MHz Channel Bandwidth_Apart AWS Path 1
Span: 1 GHz to 22 GHz RBW/VBW: 1 MHz

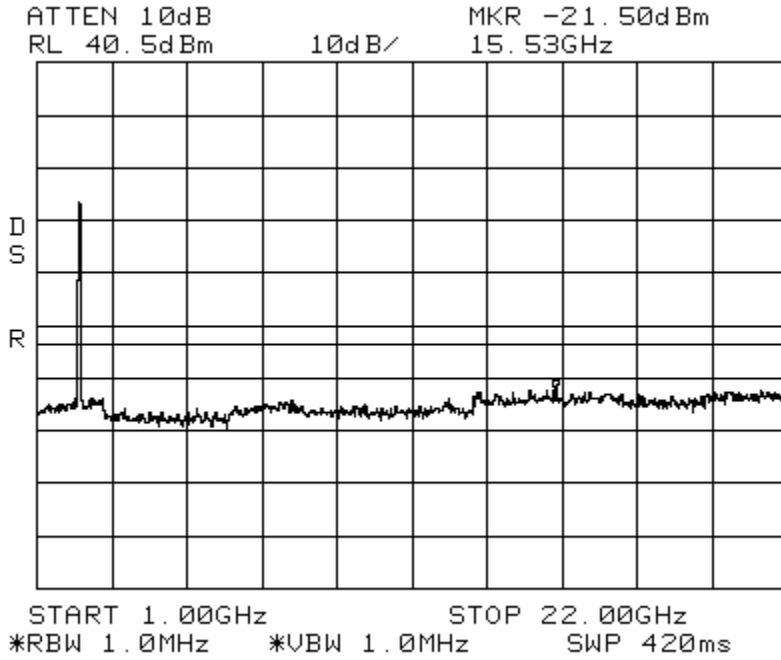

Intermodulation LTE 20 MHz Channel Bandwidth_Low AWS Path 1
Center: 2132.5 MHz Span: 90 MHz RBW/VBW: 100 kHz

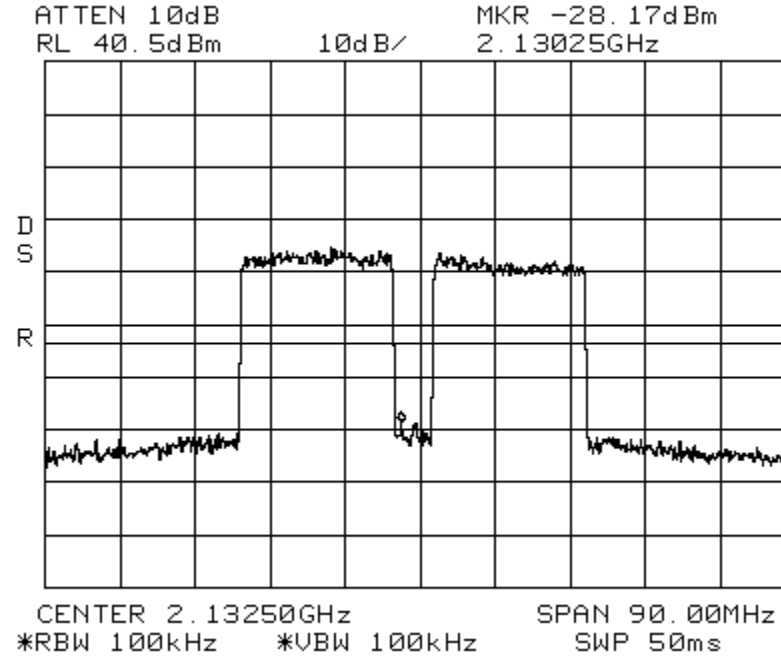

Intermodulation LTE 20 MHz Channel Bandwidth _Low AWS Path 1
Span: 30 MHz to 1 GHz RBW/VBW: 300 kHz

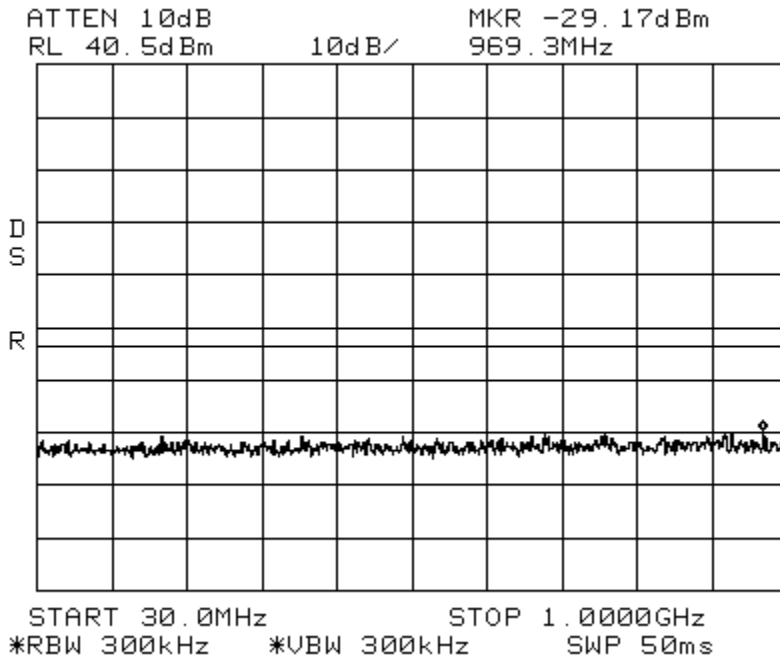

Intermodulation LTE 20 MHz Channel Bandwidth _Low AWS Path 1
Span: 1 GHz to 22GHz RBW/VBW: 1 MHz

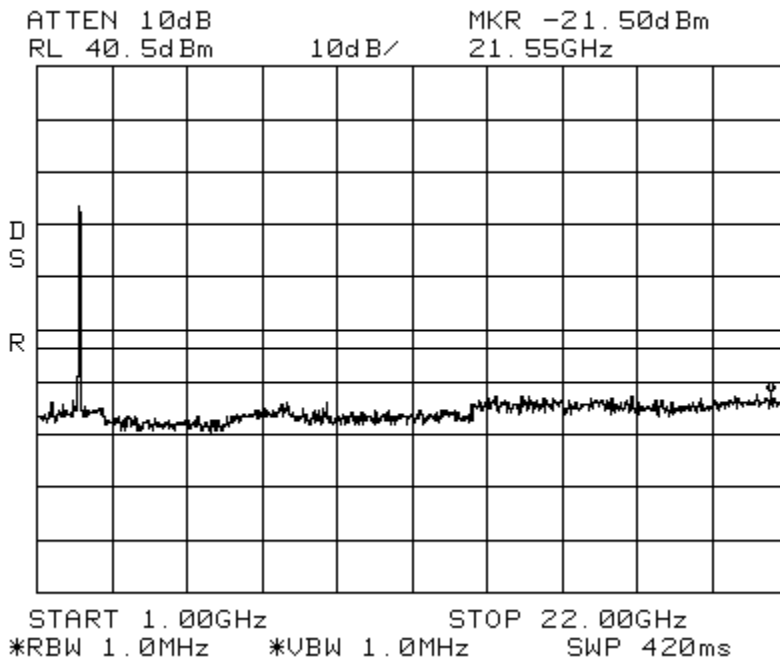

Intermodulation LTE 20 MHz Channel Bandwidth_High AWS Path 1
Center: 2132.5 MHz Span: 90 MHz RBW/VBW: 100 kHz

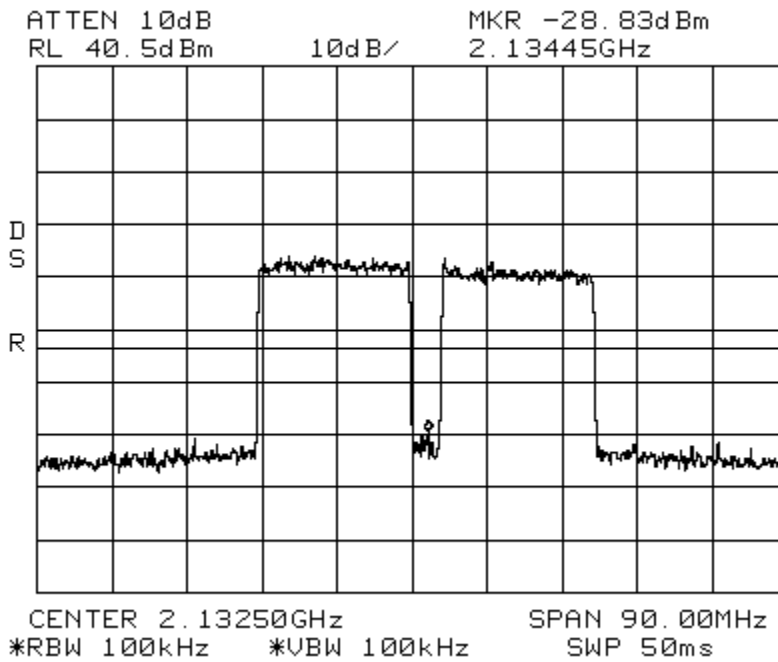

Intermodulation LTE 20 MHz Channel Bandwidth_High AWS Path 1
Span: 30 MHz to 1 GHz RBW/VBW: 300 kHz

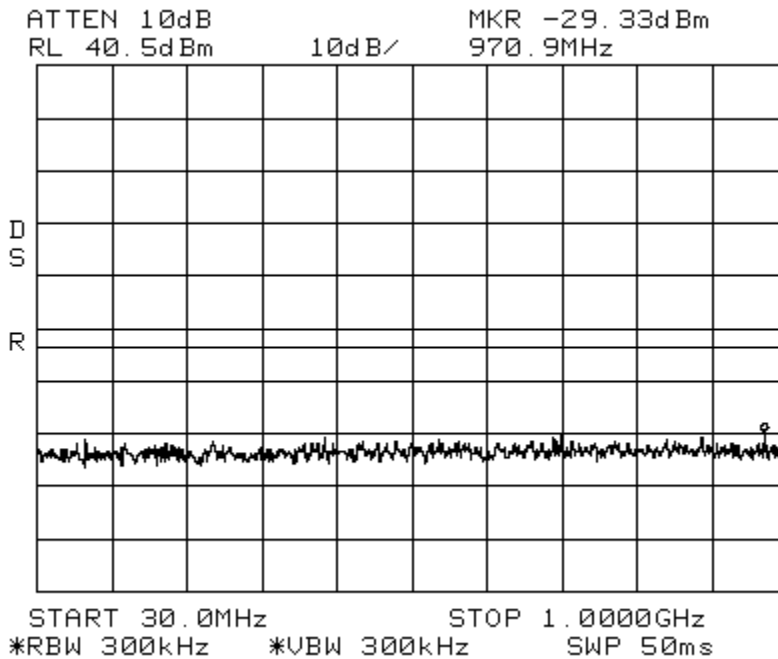

Intermodulation LTE 20 MHz Channel Bandwidth_High AWS Path 1
Span: 1 GHz to 22 GHz RBW/VBW: 1 MHz

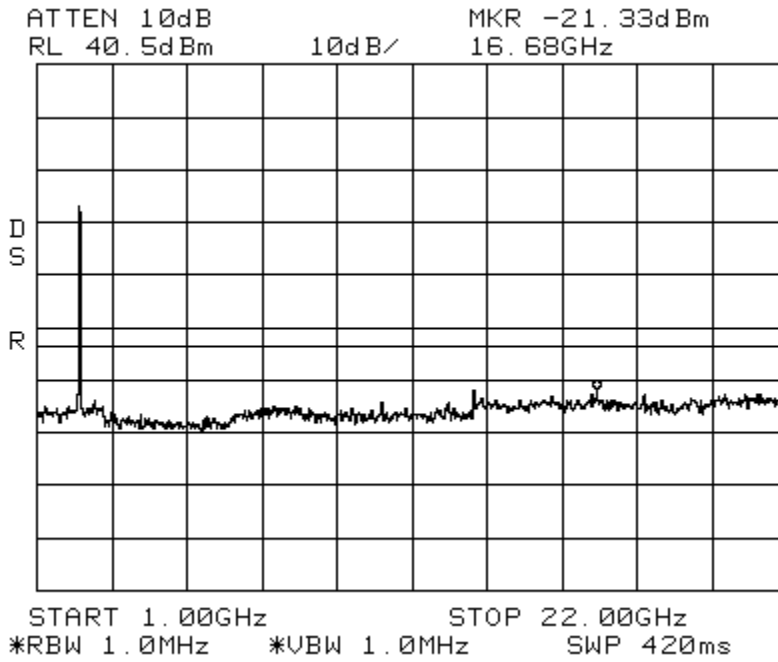

Intermodulation LTE 20 MHz Channel Bandwidth_Apart AWS Path 1
Center: 2132.5 MHz Span: 175 MHz RBW/VBW: 100 kHz

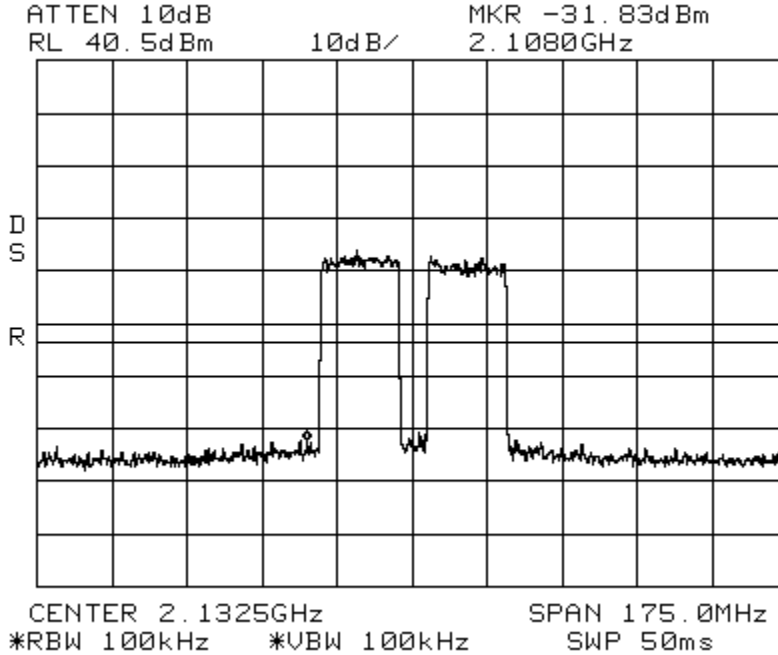

Intermodulation LTE 20 MHz Channel Bandwidth_Apart AWS Path 1
Span: 30 MHz to 1 GHz RBW/VBW: 300 kHz

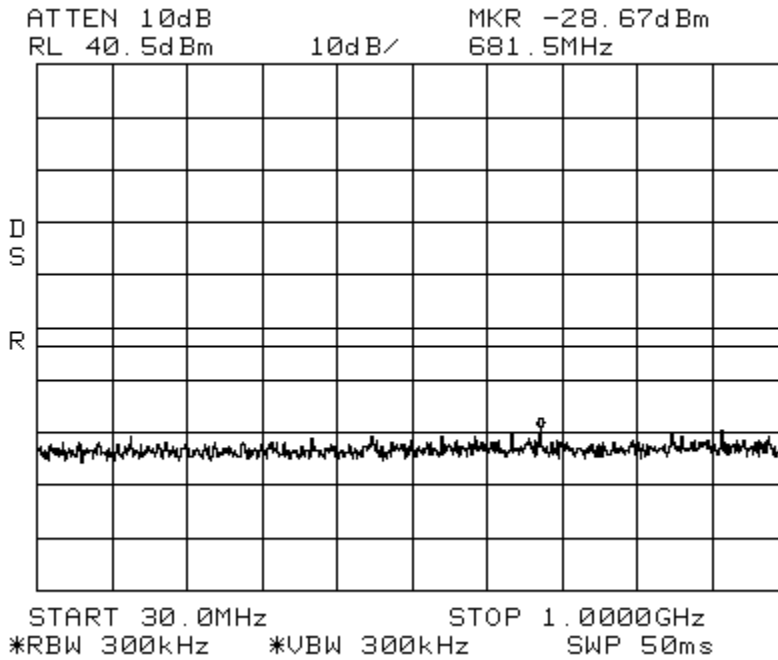

Intermodulation LTE 20 MHz Channel Bandwidth_Apart AWS Path 1
Span: 1 GHz to 22 GHz RBW/VBW: 1 MHz

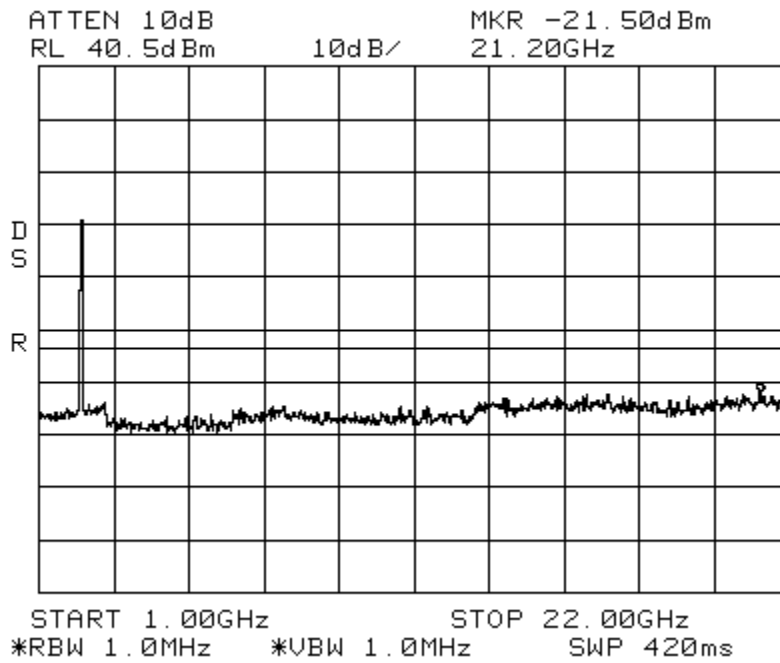

7.5 Occupied Bandwidth Modulation Test

[Table of Contents; Section 1.0](#)

[Back to Emission Limits; Section 5.1.3](#)

An input/output Occupied Bandwidth test was done with modulation types: LTE 1.4 MHz, 3 MHz, 5MHz, 10MHz, 15MHz, 20MHz Channel Bandwidths & WCDMA. The purpose was to determine the amount of distortion added to different types of modulation schemes by the EUT. The following plots show input signals vs. output signals.

The resolution bandwidth is reduced to 1% of the estimated emission bandwidth and the video bandwidth is set to 3 times the resolution bandwidth. The markers are moved to the -20 dB points (from the previously established center frequency level) on either side of center frequency.

Results:

Pass (see plots)

Occupied Bandwidth LTE 1.4 MHz Channel Bandwidth_Signal_In
Lower ABC Path 1

Spectrum 700 MHz

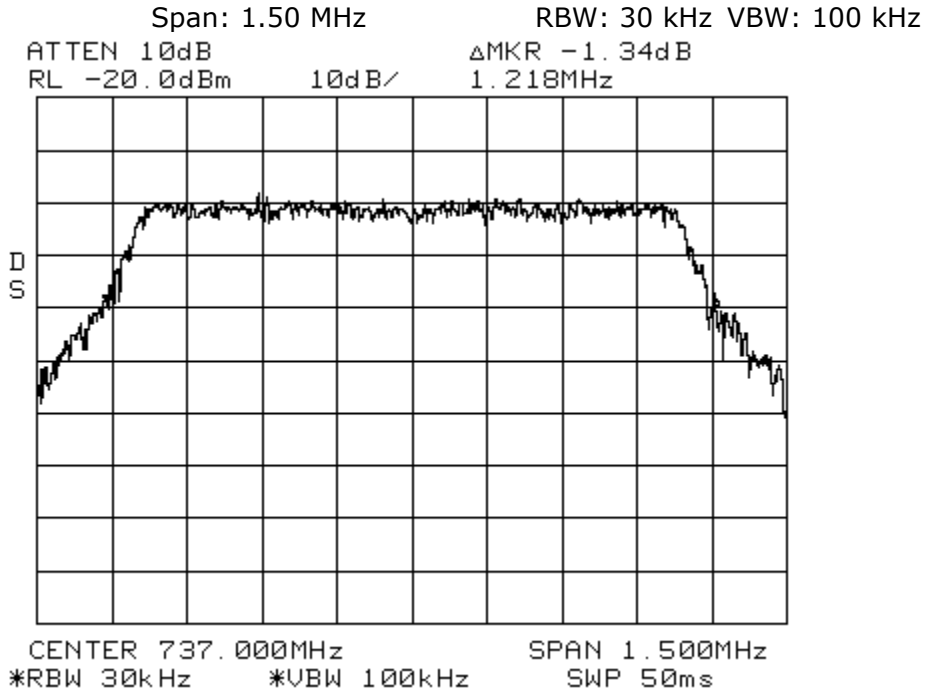

Occupied Bandwidth LTE 1.4 MHz Channel Bandwidth_Signal_Out
Lower ABC Path 1

Spectrum 700 MHz

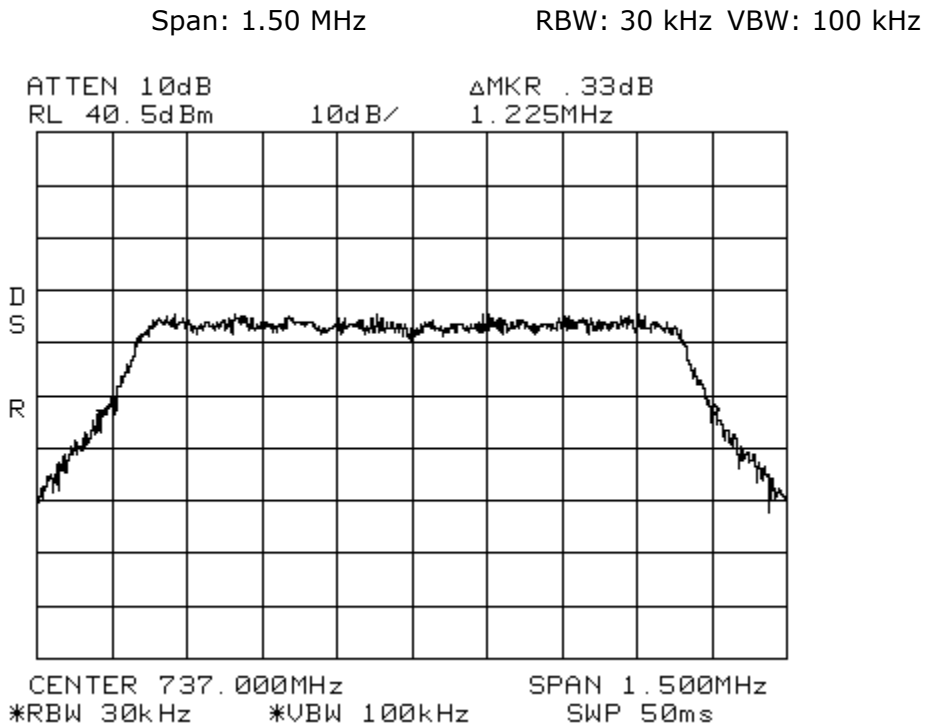

Occupied Bandwidth LTE 3 MHz Channel Bandwidth_Signal_In

Spectrum 700 MHz

Lower ABC Path 1

Span: 3 MHz

RBW: 30kHz VBW: 100 kHz

ATTEN 10dB

Δ MKR -.84dB

RL -20.0dBm

10dB/

2.890MHz

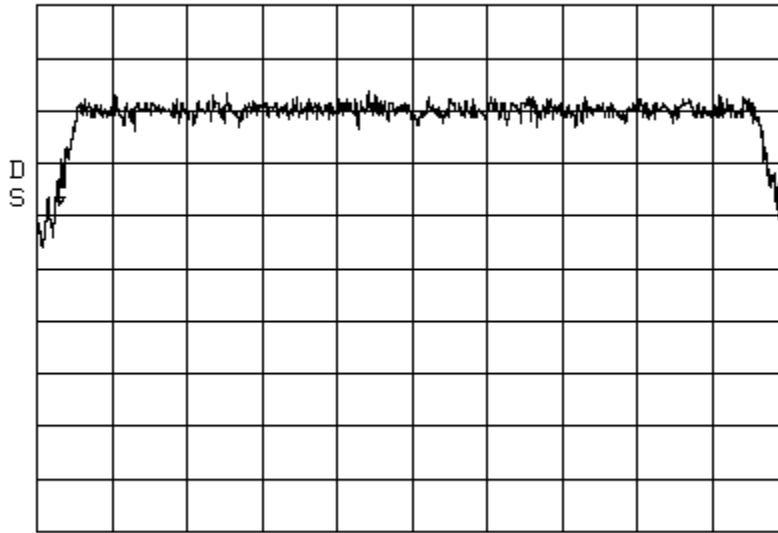

CENTER 737.000MHz SPAN 3.000MHz
 *RBW 30kHz *VBW 100kHz SWP 50ms

Occupied Bandwidth LTE 3 MHz Channel Bandwidth_Signal_Out

Spectrum 700 MHz

Lower ABC Path 1

Span: 3 MHz

RBW: 30 kHz VBW: 100 kHz

ATTEN 10dB

Δ MKR -.50dB

RL 40.5dBm

10dB/

2.875MHz

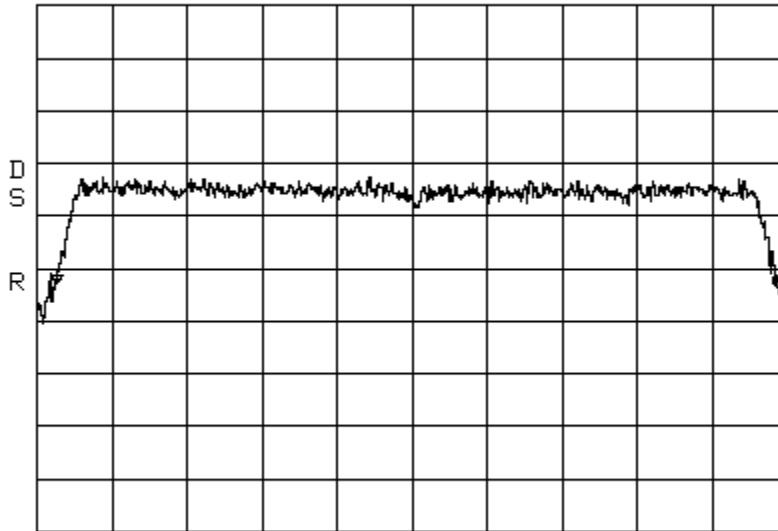

CENTER 737.000MHz SPAN 3.000MHz
 *RBW 30kHz *VBW 100kHz SWP 50ms

Occupied Bandwidth LTE 5 MHz Channel Bandwidth_Signal_In
Lower ABC Path 1

Spectrum 700 MHz

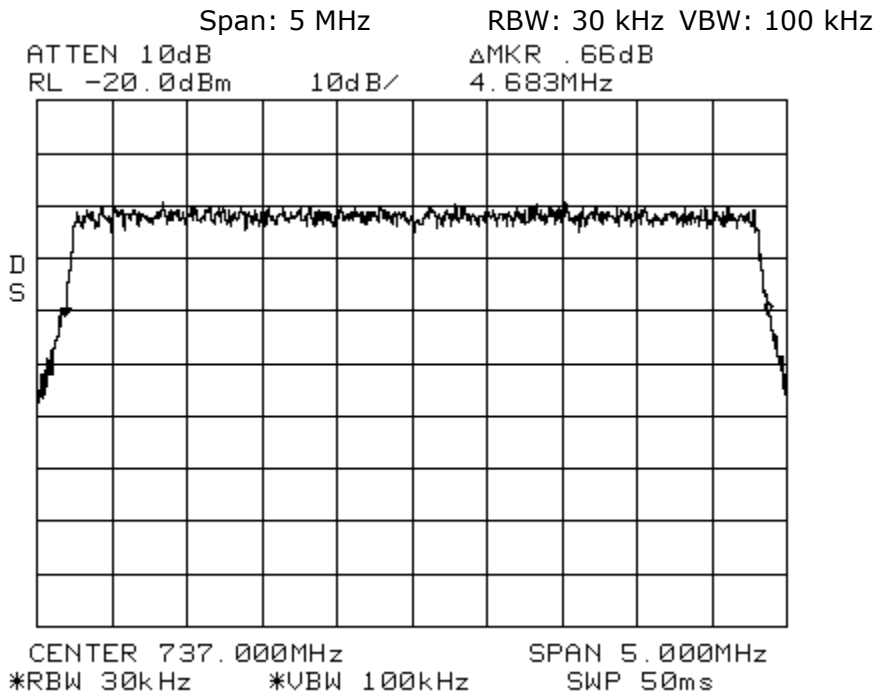

Occupied Bandwidth LTE 5 MHz Channel Bandwidth_Signal_Out
Lower ABC Path 1

Spectrum 700 MHz

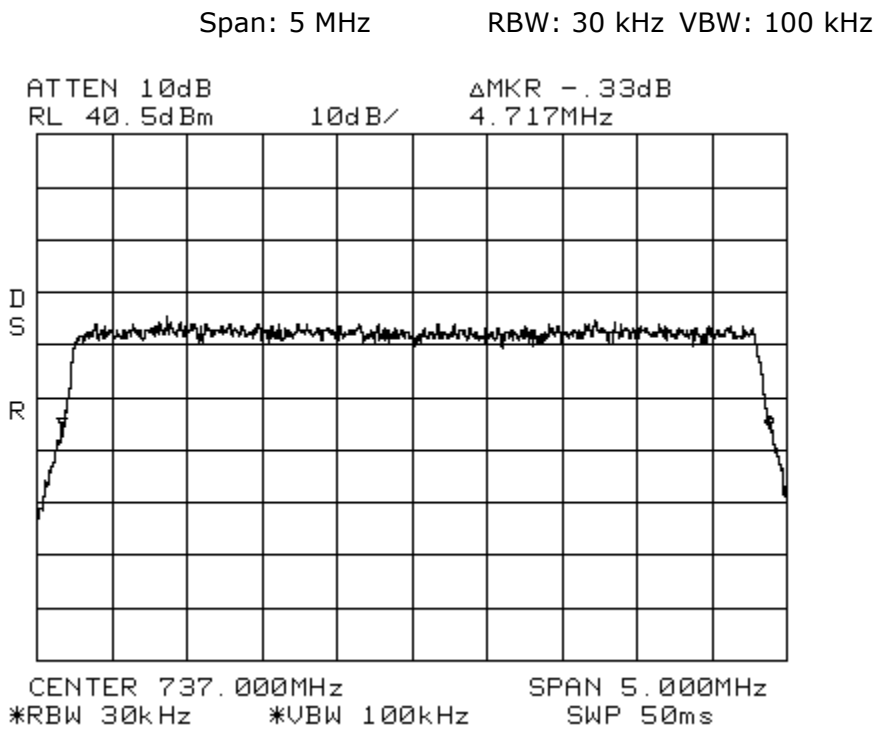

Occupied Bandwidth LTE 10 MHz Channel Bandwidth_Signal_In

Spectrum 700 MHz

Lower ABC Path 1

Span: 10 MHz

RBW: 30 kHz VBW: 100 kHz

ATTEN 10dB

Δ MKR 1.83dB

RL -20.0dBm

10dB/

9.22MHz

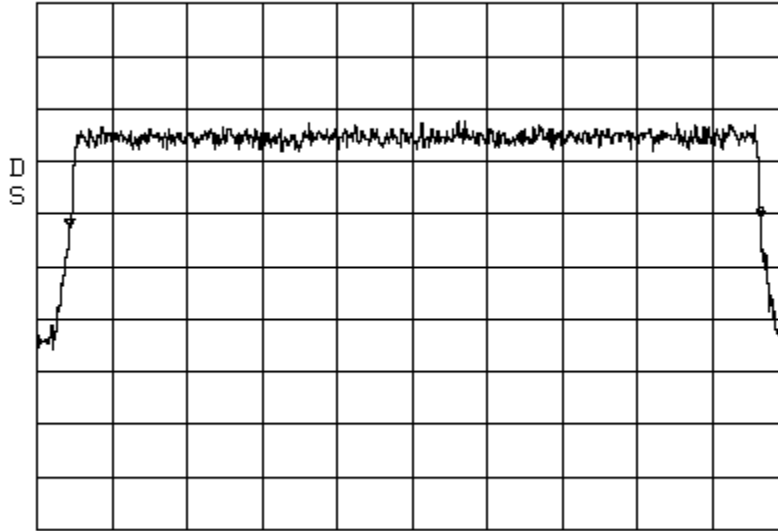

CENTER 737.00MHz SPAN 10.00MHz
*RBW 30kHz *VBW 100kHz SWP 50ms

Occupied Bandwidth LTE 10 MHz Channel Bandwidth_Signal_Out

Spectrum 700 MHz

Lower ABC Path 1

Span: 10 MHz

RBW: 30 kHz VBW: 100 kHz

ATTEN 10dB

Δ MKR .17dB

RL 40.5dBm

10dB/

9.25MHz

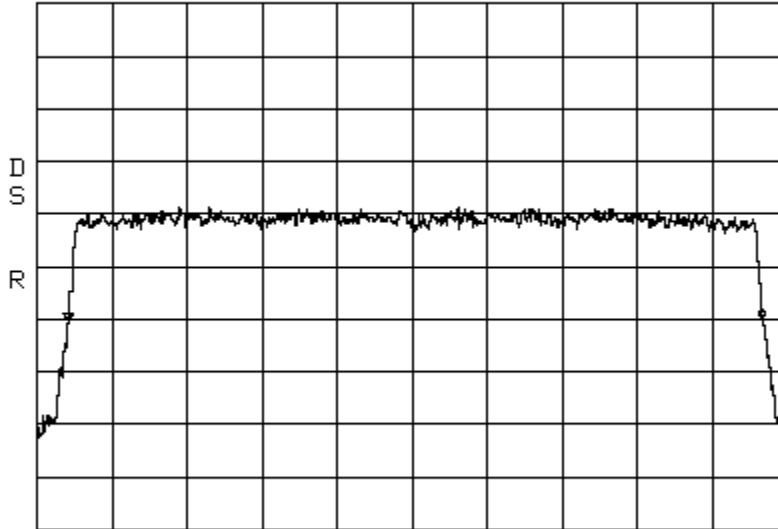

CENTER 737.00MHz SPAN 10.00MHz
*RBW 30kHz *VBW 100kHz SWP 50ms

Occupied Bandwidth LTE 1.4 MHz Channel Bandwidth_Signal_In Spectrum 700 MHz Upper C
Path 1

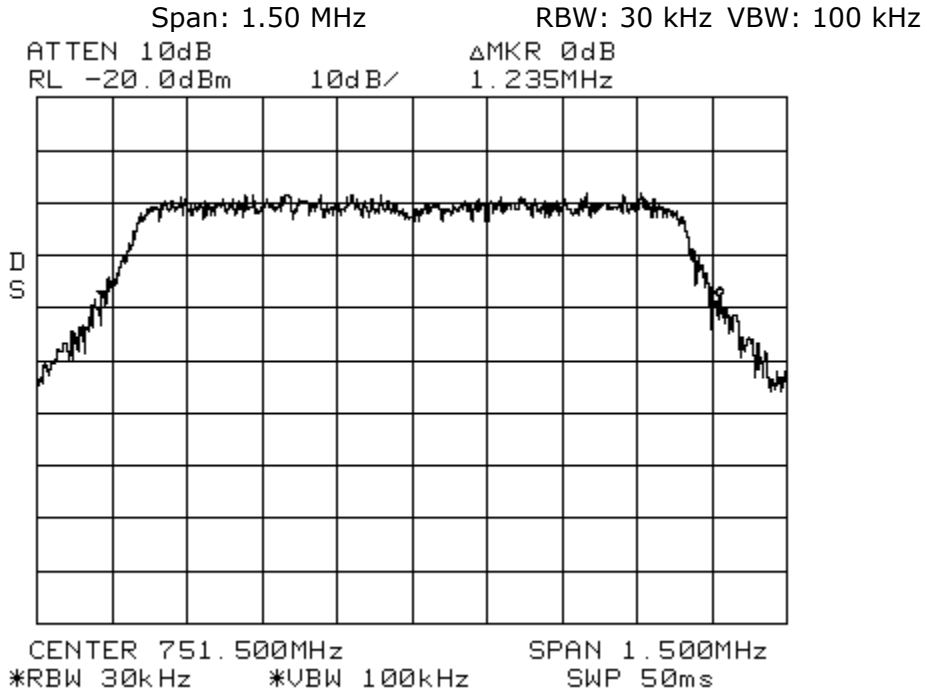

Occupied Bandwidth LTE 1.4 MHz Channel Bandwidth_Signal_Out Spectrum 700 MHz Upper C
Path 1

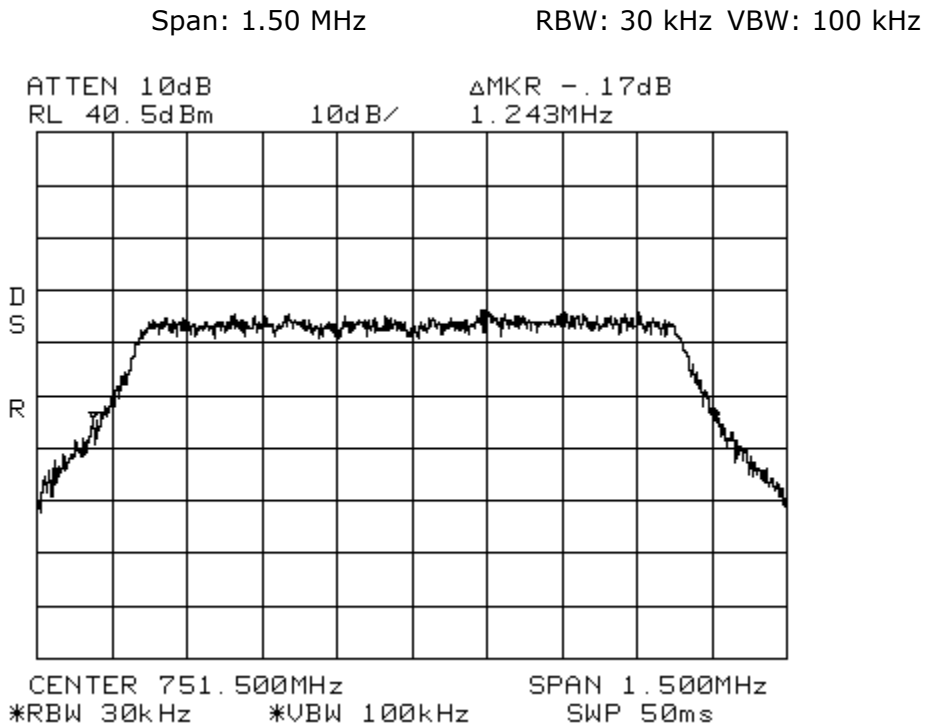

Occupied Bandwidth LTE 3 MHz Channel Bandwidth_Signal_In

Spectrum 700 MHz

Upper C Path 1

Span: 3 MHz

RBW: 30kHz VBW: 100 kHz

ATTEN 10dB

Δ MKR 1.50dB

RL -20.0dBm

10dB/

2.905MHz

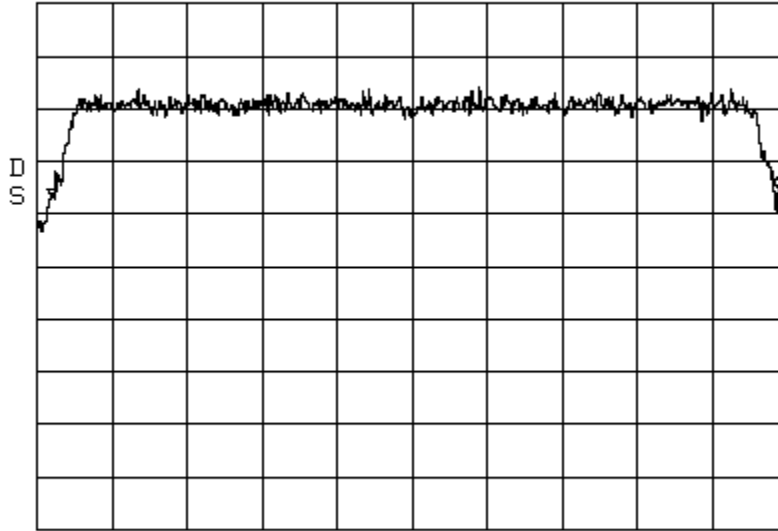

CENTER 751.500MHz SPAN 3.000MHz
 *RBW 30kHz *VBW 100kHz SWP 50ms

Occupied Bandwidth LTE 3 MHz Channel Bandwidth_Signal_Out

Spectrum 700 MHz

Upper C Path 1

Span: 3 MHz

RBW: 30 kHz VBW: 100 kHz

ATTEN 10dB

Δ MKR .16dB

RL 40.5dBm

10dB/

2.890MHz

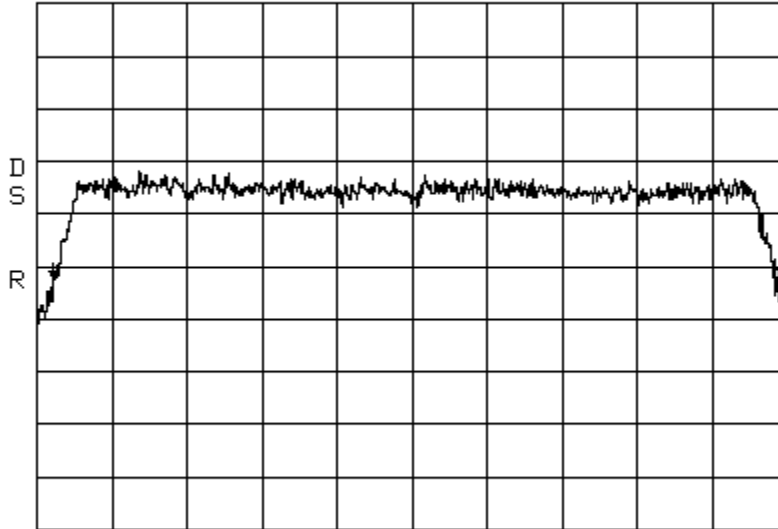

CENTER 751.500MHz SPAN 3.000MHz
 *RBW 30kHz *VBW 100kHz SWP 50ms

Occupied Bandwidth LTE 5 MHz Channel Bandwidth_Signal_In Spectrum 700 MHz Upper C Path 1

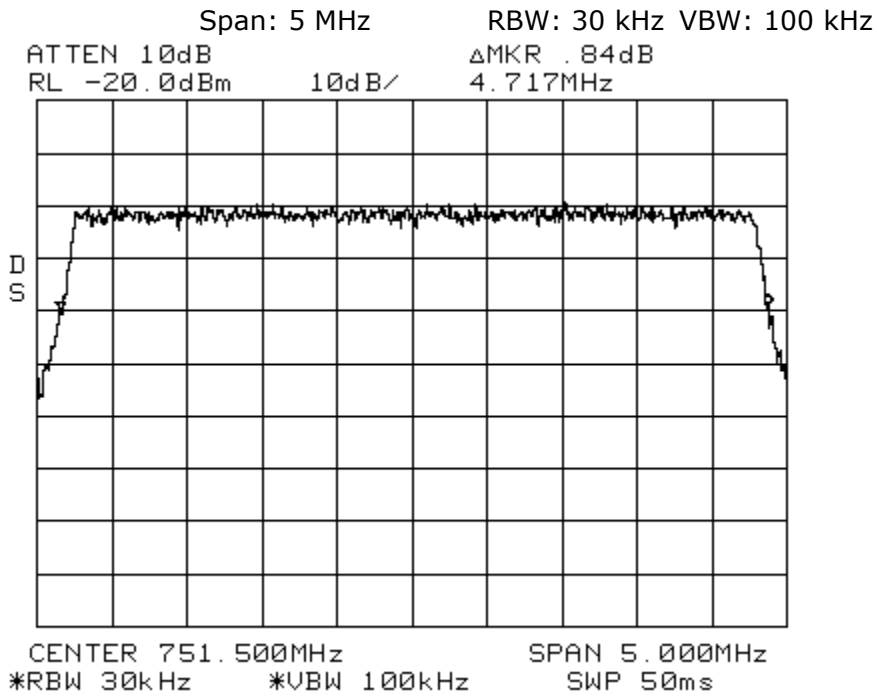

Occupied Bandwidth LTE 5 MHz Channel Bandwidth_Signal_Out Spectrum 700 MHz Upper C Path 1

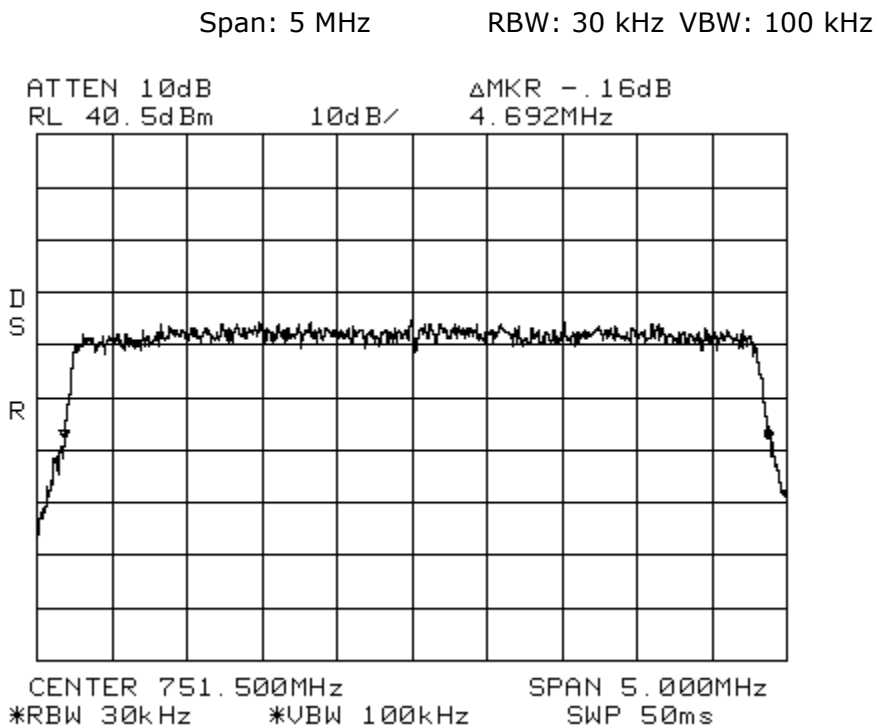

Occupied Bandwidth LTE 10 MHz Channel Bandwidth_Signal_In Spectrum 700 MHz Upper C
Path 1

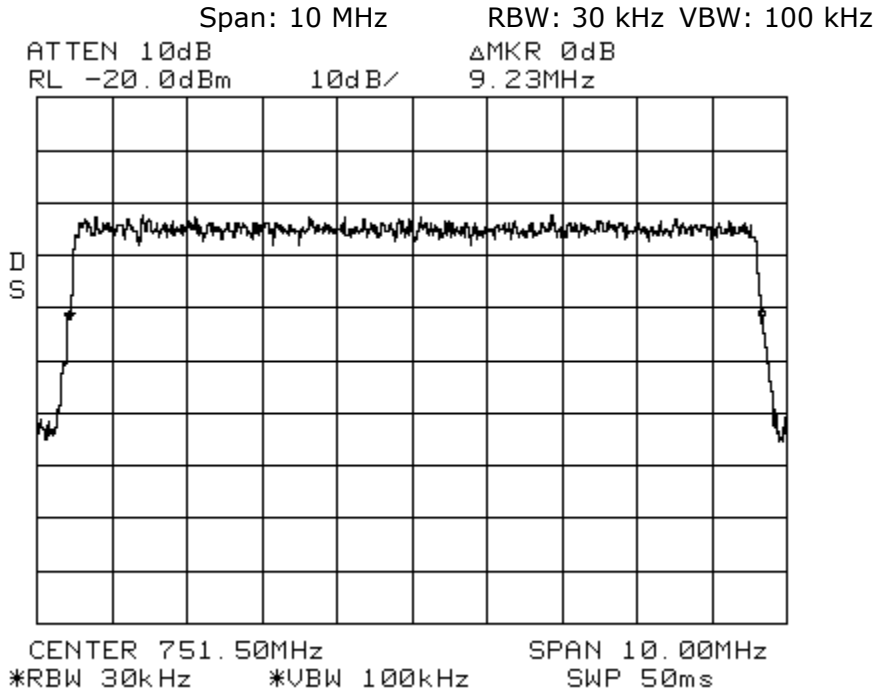

Occupied Bandwidth LTE 10 MHz Channel Bandwidth_Signal_Out Spectrum 700 MHz Upper C
Path 1

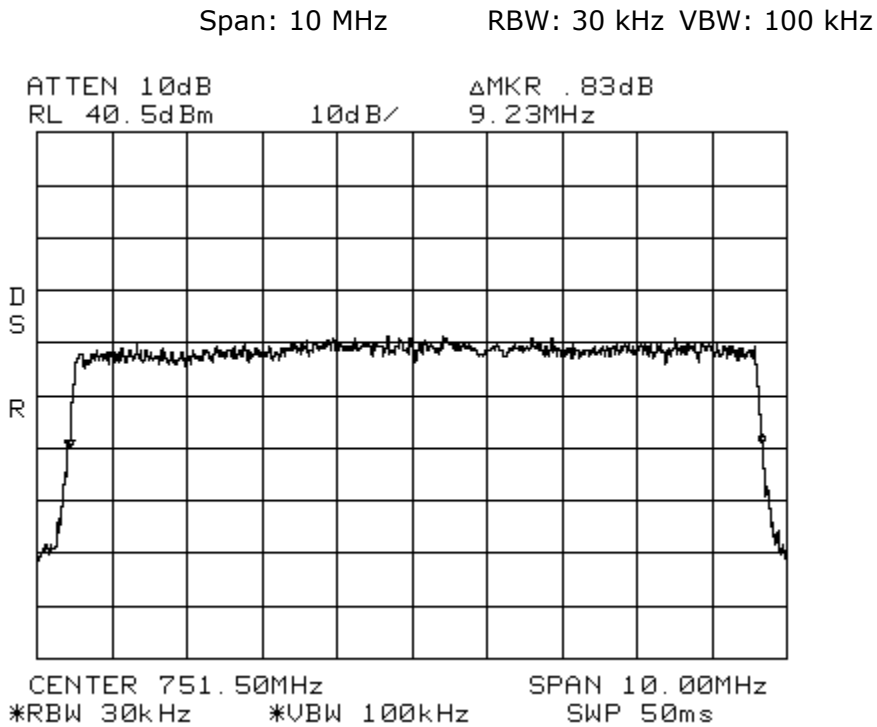

Occupied Bandwidth WCDMA_Signal_In Spectrum AWS Path 1
Span: 4.8 MHz RBW: 30 kHz VBW: 100 kHz
ATTEN 10dB ΔMKR -.17dB
RL 0dBm 10dB/ 4.575MHz

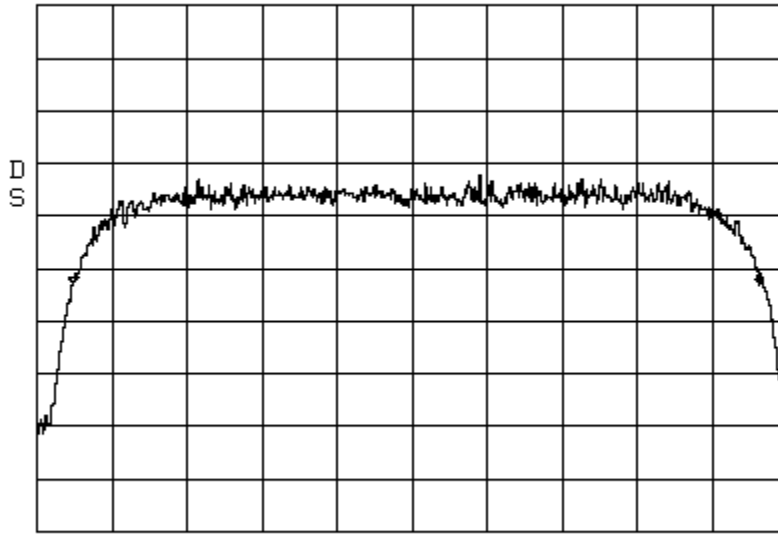

CENTER 2.13250GHz SPAN 5.000MHz
*RBW 30kHz *VBW 100kHz SWP 50ms

Occupied Bandwidth WCDMA_Signal_Out Spectrum AWS Path 1
Span: 4.8 MHz RBW: 30 kHz VBW: 100 kHz

ATTEN 10dB ΔMKR -1.00dB
RL 40.5dBm 10dB/ 4.608MHz

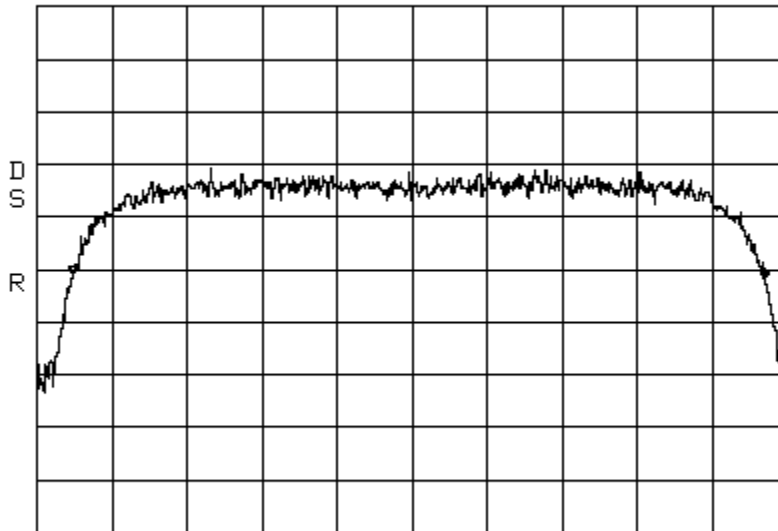

CENTER 2.13250GHz SPAN 5.000MHz
*RBW 30kHz *VBW 100kHz SWP 50ms

Occupied Bandwidth LTE 3 MHz Channel Bandwidth_Signal_In
Span: 3 MHz RBW: 30kHz VBW: 100 kHz
ATTEN 10dB ΔMKR 0dB
RL 0dBm 10dB/ 2.900MHz

AWS Path 1

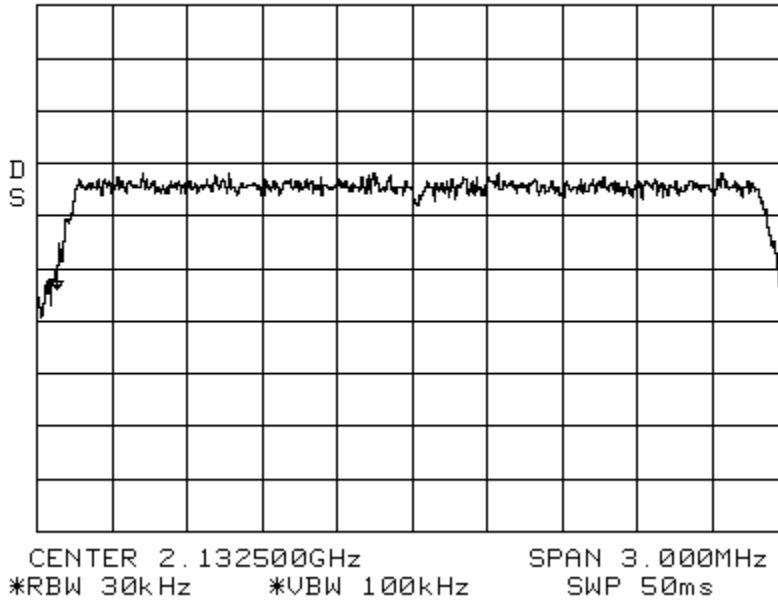

Occupied Bandwidth LTE 3 MHz Channel Bandwidth_Signal_Out
Span: 3 MHz RBW: 30 kHz VBW: 100 kHz

AWS Path 1

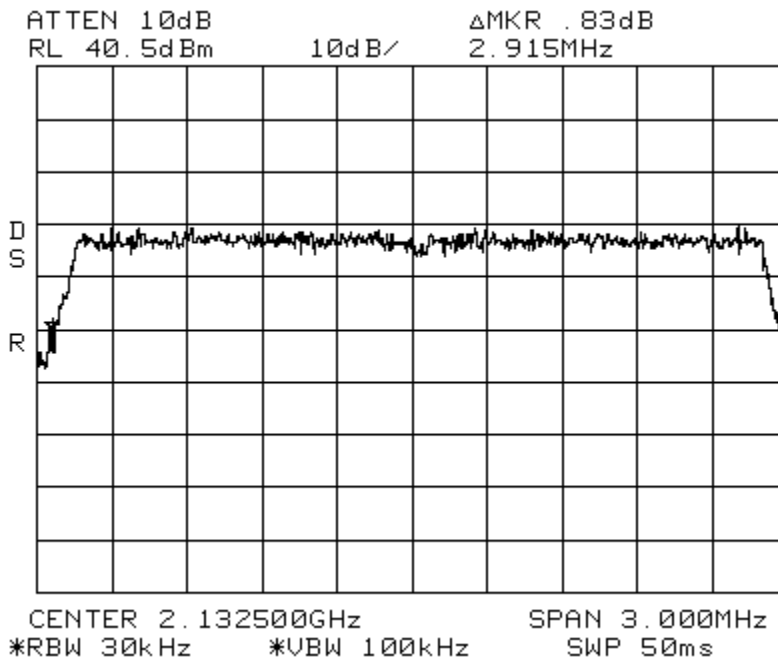

Occupied Bandwidth LTE 10 MHz Channel Bandwidth_Signal_In AWS Path 1
Span: 10 MHz RBW: 30 kHz VBW: 100 kHz

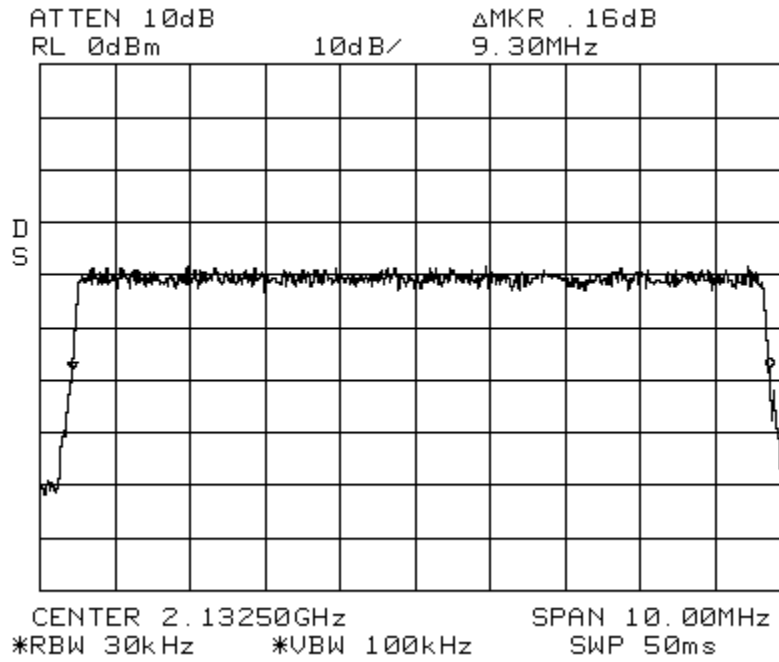

Occupied Bandwidth LTE 10 MHz Channel Bandwidth_Signal_Out AWS Path 1
Span: 10 MHz RBW: 30 kHz VBW: 100 kHz

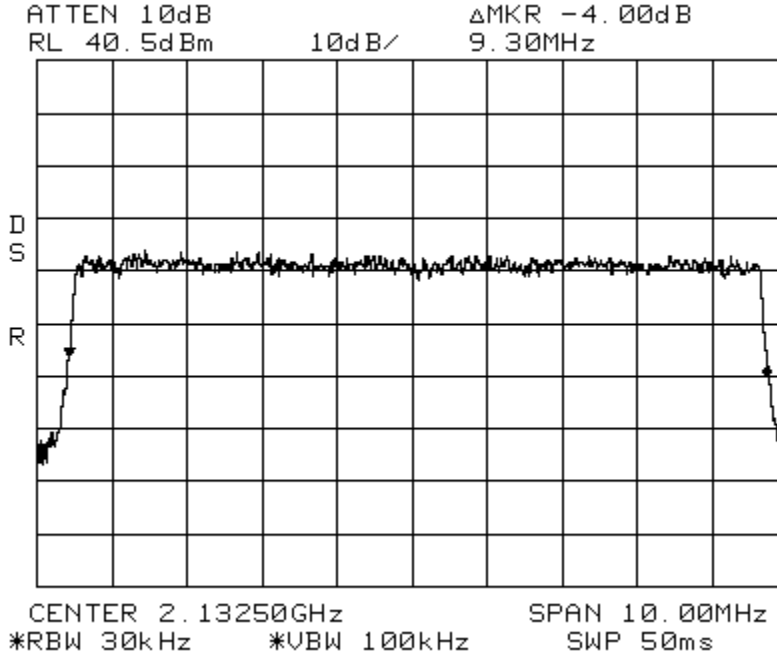

Occupied Bandwidth LTE 15 MHz Channel Bandwidth_Signal_In AWS Path 1
Span: 15 MHz RBW: 30 kHz VBW: 100 kHz

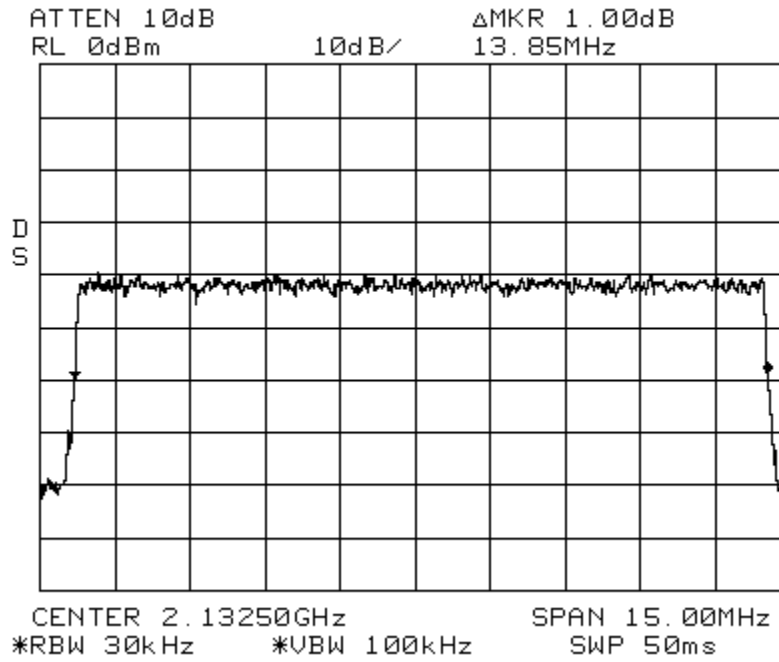

Occupied Bandwidth LTE 15 MHz Channel Bandwidth_Signal_Out AWS Path 1
Span: 15 MHz RBW: 30 kHz VBW: 100 kHz

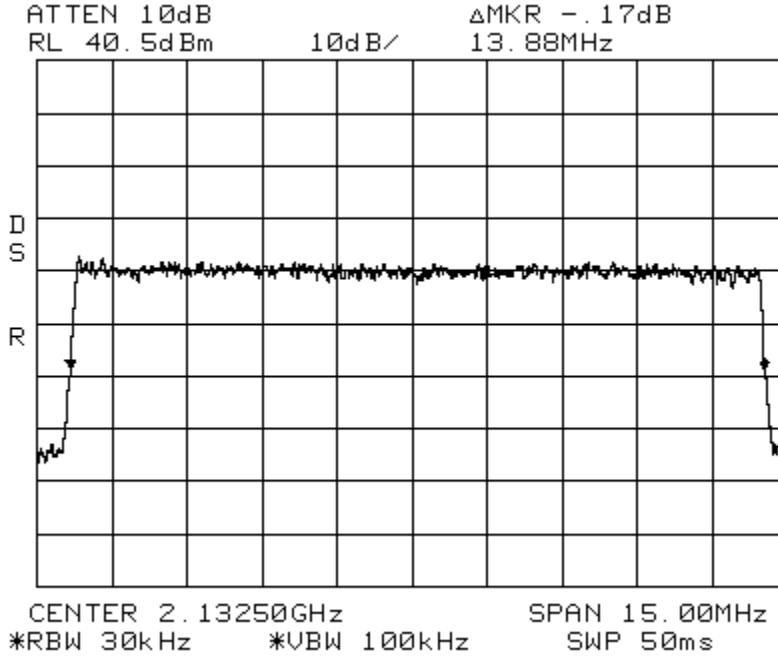

Occupied Bandwidth LTE 20 MHz Channel Bandwidth_Signal_In AWS Path 1
Span: 20 MHz RBW: 30 kHz VBW: 100 kHz

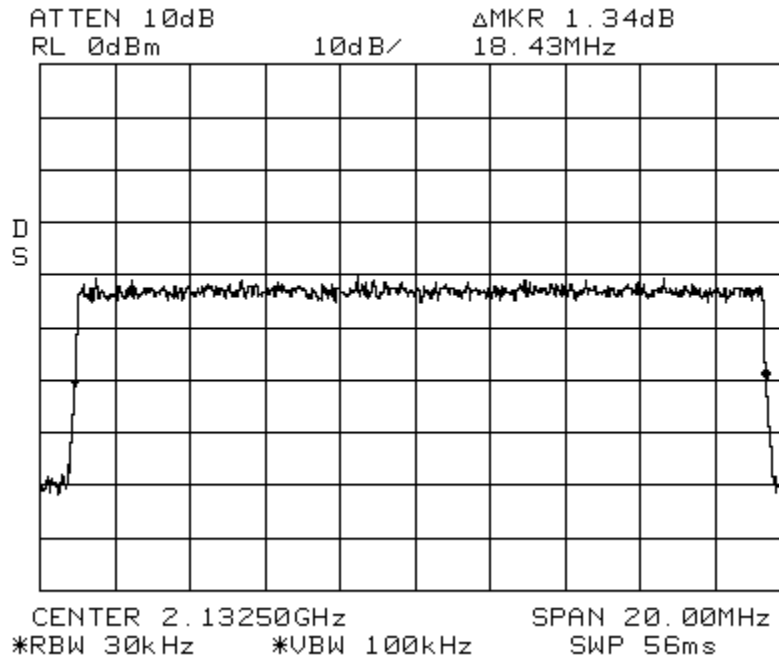

Occupied Bandwidth LTE 20 MHz Channel Bandwidth_Signal_Out AWS Path 1
Span: 20 MHz RBW: 30 kHz VBW: 100 kHz

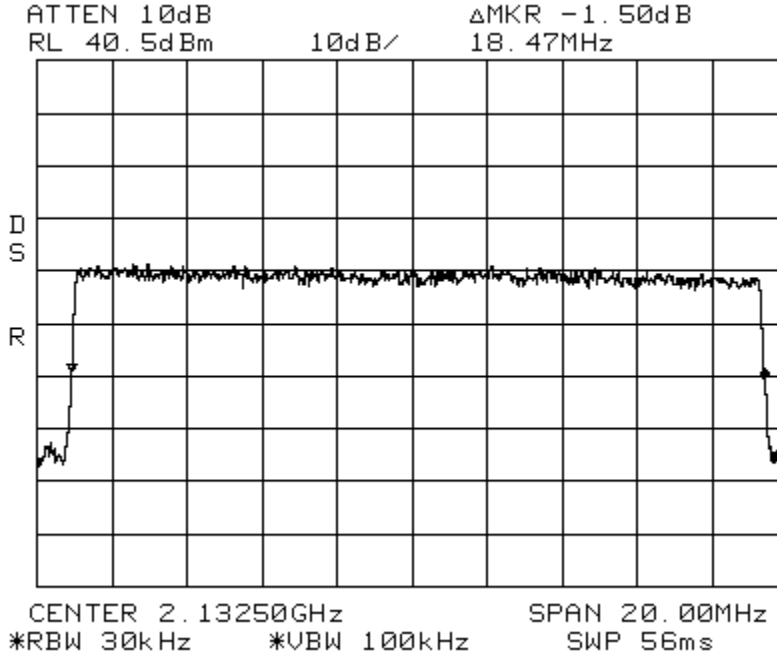

8.0

APPENDIX B

Measurement Protocol

[Table of Contents; Section 1.0](#)
[Back to Emission Limits; Section 5.1.3](#)

Measurement Protocol

Environmental conditions of the lab, (ADC)

Temperature: 25° C

Relative Humidity: 29 %

Atmospheric Pressure: 98.0 kPa

Test Methodology:

Emission testing is performed according to the procedures in ANSI C63.4-2003.

Measurement Uncertainty

The test system for conducted emissions is defined as the signal generator(s), the power meter, the spectrum analyzer and the coaxial cable. The equipment comprising the test systems is calibrated prior to testing the EUT.

Justification

The Equipment Under Test (EUT) is configured in a typical user arrangement in accordance with the manufacturer's instructions. A cable is connected to each available port and either terminated with a peripheral into its characteristic impedance or left un-terminated. When appropriate, the cables are manually manipulated with respect to each other to obtain maximum emissions from the unit.

Radiated Emissions

The final level, in dBuV/m, equals the reading from the spectrum analyzer (Level dBuV), adding the antenna correction factor and cable loss factor (Factor dB) to it, and subtracting the preamp gain (and duty cycle correction factor, if applicable). This result then has the limit subtracted from it to provide the Delta, which gives the tabular data as shown in the data sheets in Appendix B.

Example:

FREQ (MHz)	LEVEL (dBuV)	CABLE/ANT/PREAMP (dB)	FINAL (dB/m)	POL/HGT/AZ (m) (deg)	DELTA1
60.80	42.5Qp +	1.2 + 10.9 - 25.5 =	29.1	V 1.0 0.0	-10.9

Substitution Method

A cabinet (or enclosure) radiated emission scan was also made, at Intertek, with the EUT's antenna replaced with a termination to demonstrate case radiation compliance to the -13 dBm requirement. Radiated emissions from the EUT are measured in the frequency range of 30 to 20,000 MHz using a spectrum analyzer and appropriate broadband linearly polarized antennas. Table top equipment is placed on a 1.0 X 1.5 meter non-conducting table 80 centimeters above the ground plane. Floor standing equipment is placed directly on the turntable/ground plane. Interface cables that are closer than 40 centimeters to the ground plane are bundled in the center in a serpentine fashion so they are at least 40 centimeters from the ground plane. Cables to simulators/testers (if used in this test) are routed through the center of the table and to a screen room located outside the test area. The antenna is positioned 3 meters horizontally from the EUT. To locate maximum emissions from the test sample the antenna is varied in height from 1 to 4 meters, measurement scans are made with both horizontal and vertical antenna polarizations and the EUT are rotated 360 degrees. The field strength levels were measured per ANSI C63.4. The EUT is then replaced with a tuned dipole antenna (below 1GHz) or horn antenna (above 1 GHz). The substitute antenna was placed in the same polarization as the test antenna. A signal generator was used to generate a signal level that matched the highest level measured from the EUT. The signal generator level minus the cable loss from the signal generator to the substitute antenna plus the substitute antenna gain equals the spurious power level.

Test Equipment

All measurement instrumentation is traceable to the National Institute of Standards and Technology and is calibrated according to internal procedure.

Radiated Emissions Test Data

[Table of Contents; Section 1.0](#)

Document Name: 100790006MIN-001

Test Engineer: Richard Blonigen

Date: July 23, 2012

Test Procedure:

Test measurements were made in accordance with ANSI C63.4-2003, Standard Methods of Measurement of Radio Noise Emissions from Low-Voltage Electrical and Electronics Equipment in the Range of 9 kHz to 40 GHz.

Test Site Location:

The test site is a 3 meter Semi-Anechoic Chamber, constructed by Panashield™ Inc. and located inside the building at 7250 Hudson Blvd. Suite 100, Oakdale, MN 55128.

Test Site Description:

The 3 meter Semi-Anechoic Chamber is constructed of Panabolt™ modular RF shielding and self-supported with structural steel designed for the local seismic zone rating. The chamber has the nominal size of 20' wide x 29' long x 18' high. All walls and ceiling of the chamber are treated with FFG-1000 Ferrite Grid absorber which was developed specifically to meet international requirements for EMC anechoic chambers for emissions and immunity measurements. To meet high frequency testing white HY-35 hybrid absorber is mounted on the ferrites in specular regions of the chamber.

The chamber has a 2 meter diameter ANSI test volume area and meets the requirements of ANSI C63.4 (1992), EN55022, and FCC Part 15 standards for testing at a 3 meter path length.

FCC Registration Number: 0007355381

IC Registration Number: 4359A