



Test Report Summary

FCC CFR 47, Part 24

Subpart E Broadband PCS

FCC CFR 47, Part 22

Wireless Communications Service

Manufacturer: ADC Telecommunications

Name of Equipment: Spectrum CELL Path 1/PCS Path1 HP MRAU

Model Number(s): SPT-M3-8519-11-SH

Manufacturer's Address: 1187 Park Place
Shakopee, MN 55739

Test Report Number: MN120710 CELLP1 PCSP1 HP MRAU

Test Date(s): 11, 12 June, 2012 (Intertek)
20, 21, 22 June, 2012 (ADC)
10 July, 2012 (ADC)

According to testing performed at Intertek, the above-mentioned unit is in accordance with the applicable electromagnetic compatibility (EMC) portions of the requirements defined in FCC Part 22 and 24.

It is the manufacturer's responsibility to assure that additional production units of this model are manufactured with identical electrical and mechanical characteristics. Any modifications necessary for compliance made during testing on the above mentioned date(s) must be implemented in all production units for compliance to be maintained.

All testing was done in accordance with the Federal Communications Commission's CFR 47 Part 22 and 24. The EUT fulfills the requirements of the Federal Communications Commission's CFR 47 Part 22 and 24.

Date: 10 July, 2012

Location: Intertek Testing Services (INTERTEK)
7250 Hudson Blvd., Suite 100
Oakdale, MN 55128
Phone: (651) 730-1188
Fax: (651) 730-1282

ADC Telecommunications
1187 Park Place
Shakopee, MN 55379
Phone: (952) 403-8340
Fax: (952) 403-8858

Testing Conducted by (ADC):
And Report Written by:



Joshua J. Wittman
Compliance Engineer



1.0 TABLE OF CONTENTS

1.0	Table of Contents	3
2.0	Revision Description	4
3.0	Documentation	4
3.1	Test Regulations	4
3.2	Test Operation Mode	5
3.3	Configuration of the Device Under Test:	5
3.4	Product Options:	5
3.5	EUT Specifications and Requirements:	5
3.6	Cables:	5
3.7	Power Requirements:	5
3.8	Typical Installation and/or Operating Environment:	5
3.9	Other Special Requirements:	5
3.10	EUT Software:	5
3.11	EUT System Components	6
3.12	Support Equipment	6
3.13	Deviations from Standard:	6
3.14	General Remarks:	6
3.15	Summary:	6
4.0	Test Set-Up Drawings and Photos	7
4.1	Test Set-up Photo, Radiated Emissions	7
4.2	Test Set-up Photo, Radiated Emissions	8
4.3	Test Set-up Drawings	9
5.0	Test Results	11
5.1.1	27.50 RF Power Limits	11
5.1.2	27.54 Frequency Stability	12
5.1.3	27.53 Emission Limitations	13
6.0	Test Equipment	14
7.0	Appendix A	15
7.1	Conducted Emission Limits Test	16
7.2	Conducted Output Power Test	56
7.3	Frequency Stability Test	59
7.4	Intermodulation Test	62
7.5	Occupied Bandwidth Modulation Test	144
8.0	Appendix B	161
9.0	Appendix C	163



2.0 REVISION DESCRIPTION

Rev	Total Pages	Date	Description
A	163	10 July, 2012	Original Release

3.0 DOCUMENTATION

3.1 Test Regulations

- 27.50 Power limits
- 27.53 Emission limits
- 27.54 Frequency stability

The emissions tests were performed according to the following regulations:

- **FCC Part 22**
- **FCC Part 24**
- FCC Part 27
- FCC Part 90
- IC RSS-131 Issue 2

Environmental Conditions in the lab:

ADC

Temperature: 25° C
Relative Humidity: 30%
Atmospheric Pressure: 98.2 kPa

Intertek

15-35° C
30-60%
86-106 kPa

Power Supply Utilized:

Power Supply System : 1 phase, 60 Hz, 120 VAC

3.2 Test Operation Mode

- Standby
- Test Program
- Practice Operation

■ Max composite in and out

3.3 Configuration of the Device Under Test:

Normal Operation – CELL – 869 to 894 MHz
Normal Operation – PCS – 1930 to 1995 MHz

3.4 Product Options:

None

3.5 EUT Specifications and Requirements:

Length: 11.50"
Width: 9.00"
Height: 3.50"
Weight: 7.49 pounds

3.6 Cables:

Cable Type	Length	From	To
RF	> 3M	Ancillary Equip	EUT
RF	< 3M	EUT	50 Ohm Load
Power (2)	< 3M	Power	Input Power (Ancillary)
Coax (75 Ohm)	> 3M	Ancillary Equip	EUT

3.7 Power Requirements:

Voltage: 54 VDC

3.8 Typical Installation and/or Operating Environment:

Indoor. System is typically employed as an indoor repeater.

3.9 Other Special Requirements:

None

3.10 EUT Software:

Revision Level: Version V.6 or greater
Description: Internet Explorer

3.11 EUT System Components

Description	Model #	Serial #	FCC ID #
Prism Host Unit	FWP-0000HUII	None	
Spectrum DRU	SPT-0000DRUII	None	
Spectrum IFEU	742735-0	None	
Spectrum Power Supply	LTPCPR1U3C-Z-527		
Remote Access Unit	SPT-M3-8519-11-SH	None	

3.12 Support Equipment

Description	Manufacturer	Model #	FCC ID #
Power Meter	HP	437B	
Signal Generator	Agilent	8648C	

3.13 Deviations from Standard:

Modifications required to pass:

As indicated on the data sheet(s)

■ **None**

Test Specification Deviations; Additions to or Exclusions from:

As indicated in the Test Plan

■ **None**

3.14 General Remarks:

None.

3.15 Summary:

The requirements according to the technical regulations are

■ **met**

not Met

The equipment under test does

■ **fulfill the general approval requirements mentioned in Section 3.1.**

not fulfill the general approval requirements mentioned in Section 3.1.

4.0 TEST SET-UP DRAWINGS AND PHOTOS

[Table of Contents; Section 1.0](#)

4.1 Test Set-up Photo, Radiated Emissions

See Intertek report: 100779277MIN-001

4.2 Test Set-up Photo, Radiated Emissions

See Intertek report: 100779277MIN-001

4.3 Test Set-up Drawings

Conducted and Radiated Emission Limits Test

Conducted Output Power Test

Inter-Modulation Test

Occupied Bandwidth Modulation Test

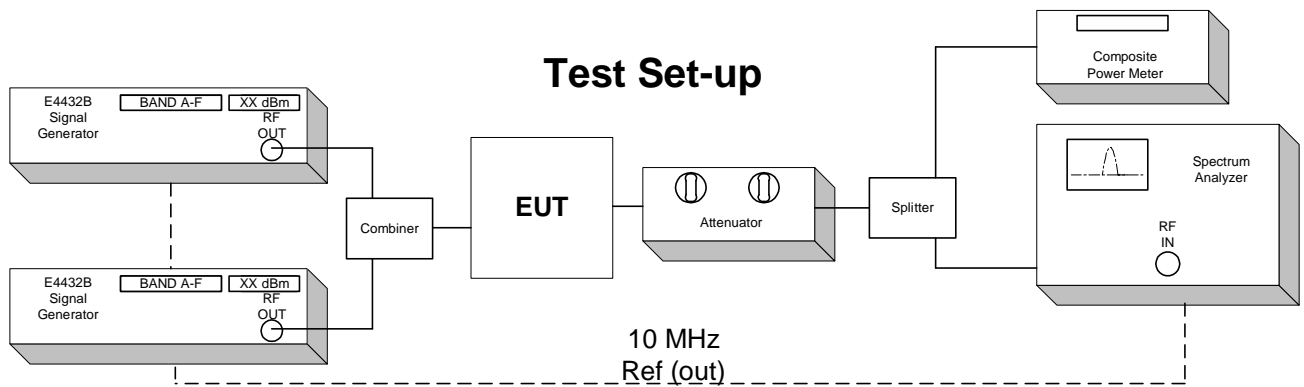

Frequency Tolerance Test

The Host, DRU, and IFEU EUT are specified for indoor use with temperature range of 0° to +50° C, and were tested within their range.

The Remote Access Unit EUT is specified for indoor use with temperature range of -25° to +50° C, and was tested with its range.

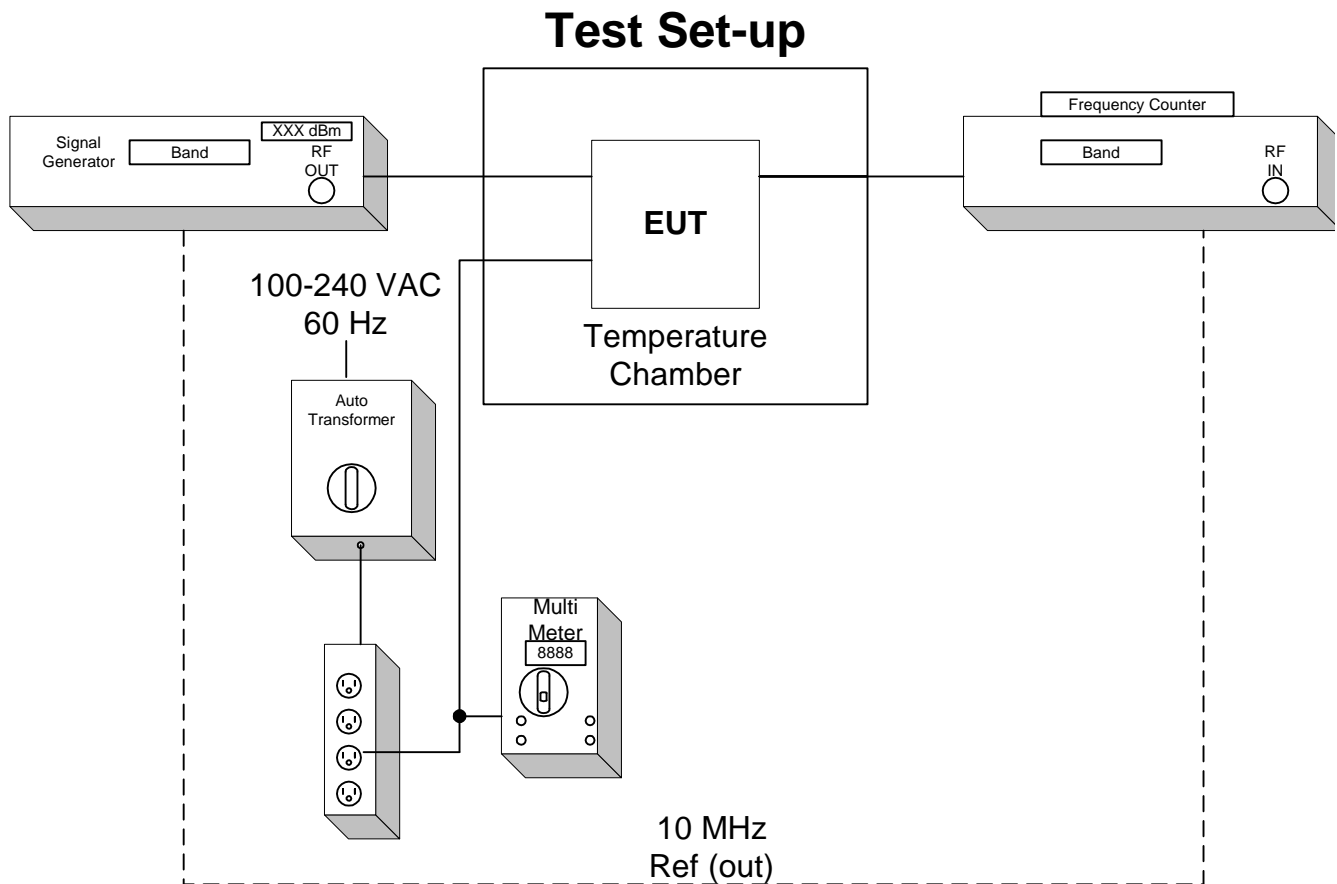

5.0 TEST RESULTS

5.1.1 27.50 RF Power Limits

Test Summary:

- The requirements are: **MET** NOT MET
- Minimum margin of compliance is 25.55 dB at 1962.5 MHz (CDMA)
- Minimum margin of compliance is 27.53 dB at 1962.5 MHz (GSM)
- Minimum margin of compliance is 27.83 dB at 1962.5 MHz (EDGE)
- Minimum margin of compliance is 23.26 dB at 1962.5 MHz (W-CDMA)
- Minimum margin of compliance is 23.99 dB at 1962.5 MHz (LTE3MHz)
- Minimum margin of compliance is 23.33 dB at 1962.5 MHz (LTE5MHz)
- Minimum margin of compliance is 23.79 dB at 1962.5 MHz (LTE10MHz)
- Minimum margin of compliance is 23.48 dB at 1962.5 MHz (LTE15MHz)
- Minimum margin of compliance is 23.48 dB at 1962.5 MHz (LTE20MHz)
- Minimum margin of compliance is 24.93 dB at 881.5 MHz (CDMA)
- Minimum margin of compliance is 28.47 dB at 881.5 MHz (GSM)
- Minimum margin of compliance is 26.97 dB at 881.5 MHz (EDGE)
- Minimum margin of compliance is 19.73 dB at 881.5 MHz (W-CDMA)
- Minimum margin of compliance is 20.30 dB at 881.5 MHz (LTE3MHz)
- Minimum margin of compliance is 19.12 dB at 881.5 MHz (LTE5MHz)
- Minimum margin of compliance is 18.90 dB at 874.0 MHz (LTE10MHz)

Test Location:

INTERTEK (Oakdale, MN)

ADC facility (Shakopee, MN)

Test Distance:

3 Meters

10 Meters

Conducted measurement

Test Equipment (ADC):

1, 2, 6, 7, 12

Test Limit:

100 Watts or 50 dBm Limit

Test Data:

[Conducted Output Power; Section 7.2](#)

[Table of Contents; Section 1.0](#)

Test Engineer: Joshua J. Wittman

Date: 20 June, 2012

5.1.2 27.54 Frequency Stability

Test Summary:

- The requirements are: **MET** NOT MET
- The fundamental emission stays within the limit.
- Frequency measured over a temperature range of -25 to 50° C and an input voltage range of 100 to 240 VAC.

Test Location:

INTERTEK (Oakdale, MN)

ADC facility (Shakopee, MN)

Test Equipment (ADC):

3, 4, 5, 6, 9,11,12

Test Limit:

The frequency stability shall be sufficient to ensure that the fundamental emission stays within the authorized frequency block.

Test Data:

[Frequency Stability; Section 7.3](#)

[Table of Contents; Section 1.0](#)

Test Engineer: Joshua J. Wittman

Date: 20 June, 2012

5.1.3 27.53 Emission Limitations

Test Summary:

- The requirements are: **MET** NOT MET
- Out of band emissions were less than -13 dBm.
- Outside the emission bandwidth of the carrier, all emissions are attenuated at least 26 dB below the transmitter power.

Test Location:

INTERTEK (Oakdale, MN)

ADC facility (Shakopee, MN)

Test Equipment (ADC):

1, 2, 6, 7, 12, 13

Test Limit:

Out of band emissions:

Attenuated below the transmitting power (P) by a factor of at least $43 + 10\log(P)$ dB, or -13 dBm.

Outside of the carrier emissions bandwidth:

26 dB below the transmitter power

Test Data:

[Conducted Emissions; Section 7.1](#)

[Intermodulation; Section 7.4](#)

[Occupied Bandwidth; Section 7.5](#)

Radiated Emissions; ([Appendix B](#))

[Table of Contents; Section 1.0](#)

Test Engineer: Joshua J. Wittman

Date: 21 June, 2012

22 June, 2012

10 July, 2012

6.0 TEST EQUIPMENT

[Table of Contents; Section 1.0](#)

Number	Description	Manufacturer	Model	ADC TELECOMMUNICATIONS Serial Number	Cal Due	Used
1	Spectrum Analyzer	HP	8563E	MC27690	6-30-13	<input checked="" type="checkbox"/>
2	Power Meter	HP	437B	MC27754	6-30-13	<input checked="" type="checkbox"/>
3	Multimeter	Fluke	79	MC18758	6-30-13	<input checked="" type="checkbox"/>
4	Frequency Counter	HP	5347A	MC27569	6-30-13	<input checked="" type="checkbox"/>
5	Temperature Chamber	ESPEC	PSL-4G	MC10075	9-8-12	<input checked="" type="checkbox"/>
6	Signal Generator	Aeroflex	3413	MC57343	11-9-12	<input checked="" type="checkbox"/>
7	Signal Generator	Aeroflex	3414	341001/259	6-13-13	<input checked="" type="checkbox"/>
8	Variable Auto Transformer	Staco	1520CT	MC44655	CNR	<input checked="" type="checkbox"/>
9	Digital Barometer	Fisher Scientific	02-403	MC50719	1-25-13	<input checked="" type="checkbox"/>
10	Attenuator	Aeroflex	49-30-33	N/A	CNR	<input checked="" type="checkbox"/>
11	Attenuator	Aeroflex	86-30-12	N/A	CNR	<input checked="" type="checkbox"/>
12	RF Power Sensor	Agilent	8481A	MC27649	6-30-12	<input checked="" type="checkbox"/>
13	Spectrum Analyzer	Rohde & Schwarz	FSQ-8	MC57131	2-15-13	<input checked="" type="checkbox"/>

Equipment with a Calibration Not Required (CNR) listing is verified and compensated for with NIST traceable calibrated equipment.

7.0

APPENDIX A

Conducted Emissions Test Data

[Table of Contents; Section 1.0](#)

Test Engineer: Joshua J. Wittman

7.1 Conducted Emission Limits Test

[Table of Contents; Section 1.0](#)

[Back to Emission Limits; Section 5.1.3](#)

The out of band emissions were measured directly from the EUT antenna output in the TX path using a spectrum analyzer from 30 MHz to the 10th harmonic of the highest carrier frequency. Test signals used are CDMA, GSM, EDGE, WCDMA, LTE 3MHz, LTE 5MHz, LTE 10MHz, LTE 15MHz, & LTE 20MHz. The different signals were input one at a time to the EUT. In all cases, the out of band emissions were less than -13 dBm from the equation
(19dBm - [43 + 10log(0.08W)])

Band edge compliance is also demonstrated using a CDMA, GSM, EDGE, WCDMA, LTE 3MHz, LTE 5MHz, LTE 10MHz, LTE 15MHz, & LTE 20MHz signal at the upper and lower limits of the band.

The Prism Host, Spectrum DRU, and Spectrum IFEU are Part 15 devices and have been tested and are compliant as such.

Industry practice has generally set the input signal power level. Test signal used was \approx -11 dBm input to Prism Host in the TX Path.

Industry practice has generally set the output signal power level.

Prism Host:	Spectrum DRU:	Spectrum IFEU	Remote Access Unit(RAU):
Range: 21 - 60 VDC	Range: 21 - 60 VDC	Range: 54 VDC	Range: 54 VDC
Tested @: 54 VDC	Tested @: 54 VDC	Tested @: 54 VDC	Tested @: 54 VDC

Application details for 2.1033(c)(10), and 2.1033(c)(13):

Final RF Amplifier Input DC Voltage and Current: 7.3V at 400mA

PLL creates all the Local Oscillators that convert signal to IF and RF signals. When PLL is unlocked the band is shut down, this is to avoid transmission of any incorrect frequency.

Internal to the electronics, the use of SAW filters provides for higher Q roll-off at band edges.

This equipment does not modulate the RF, so there is no modulation limiter. This equipment does not change the modulation of the RF or the occupied bandwidth of any channel. It transports the signal, as is, over TV (IF) coax cable. The RF input is not changed in the RF output.

This is a constant gain device, so the setup controls the output. There is an overdrive and overpower limit control that prevents excess power.

Results:
Pass (See plots)

Conducted Emissions
Center: 881.5 MHz Span: 5 MHz

CDMA
RBW/VBW: 100 kHz

Spectrum CELL

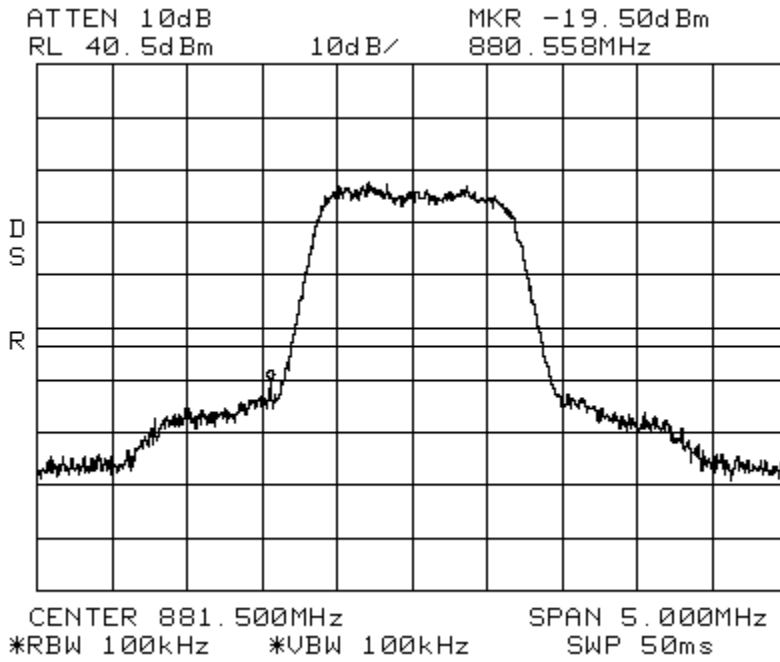

Conducted Emissions
Span: 30 MHz to 1 GHz

CDMA
RBW/VBW: 300 kHz

Spectrum CELL

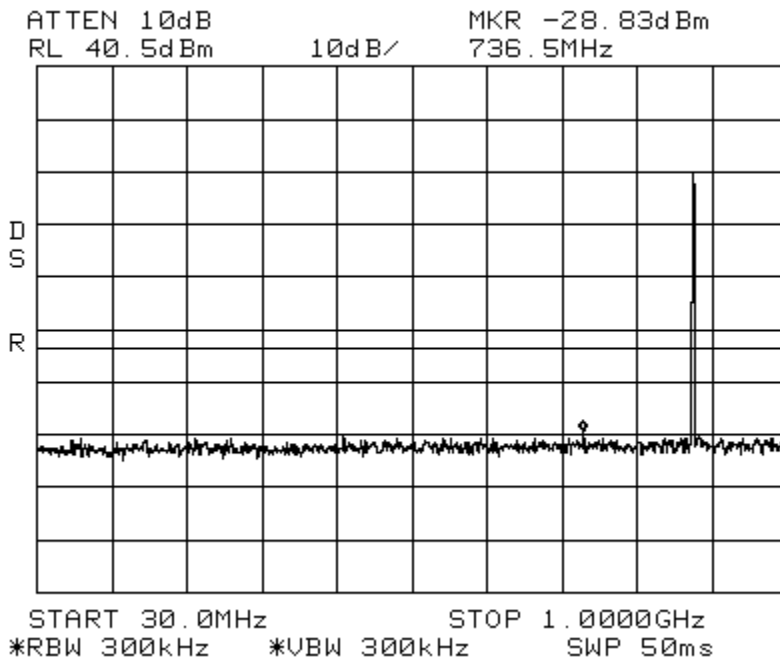

Conducted Emissions
Span: 1 GHz to 10 GHz

CDMA
RBW/VBW: 1 MHz

Spectrum CELL

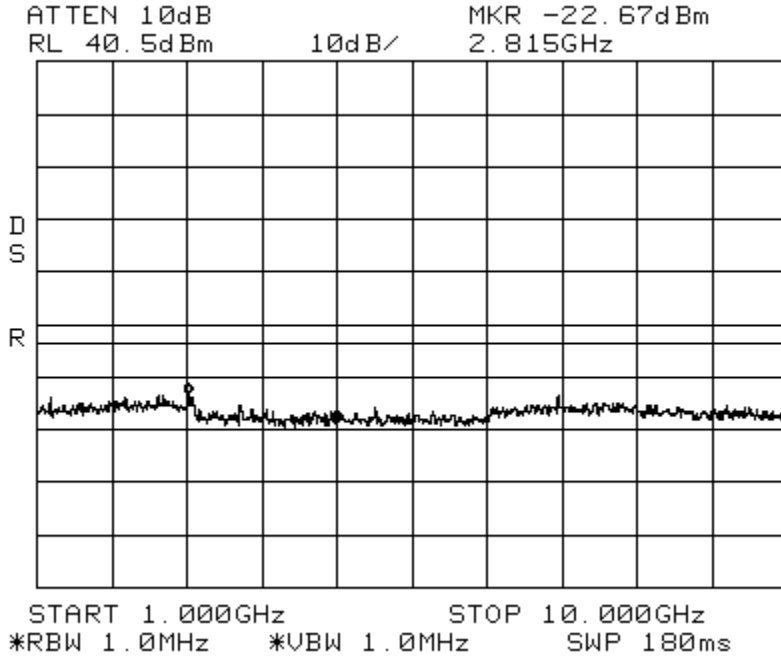

Conducted Emissions
Center: 881.5 MHz Span: 5 MHz

EDGE
RBW/VBW: 100 kHz

Spectrum CELL

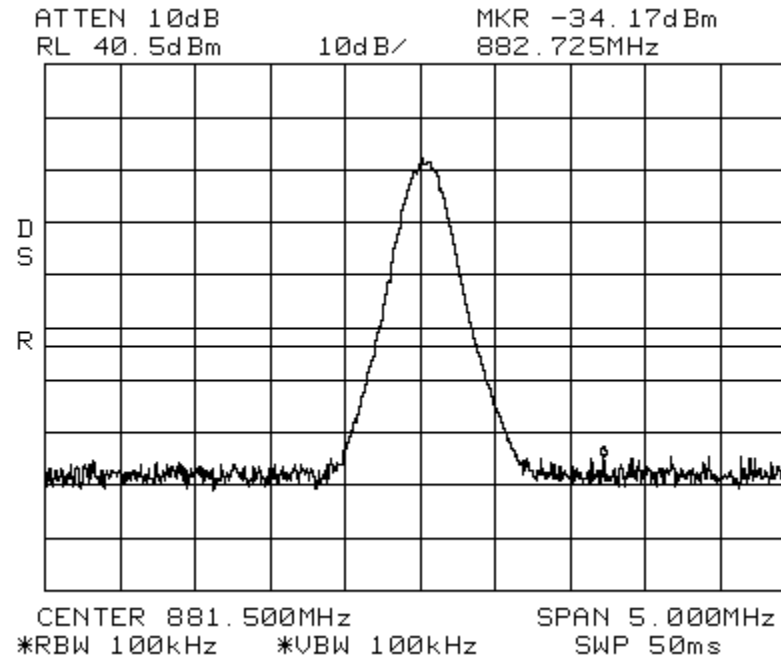

Conducted Emissions
Span: 30 MHz to 1 GHz

EDGE

Spectrum CELL
RBW/VBW: 300 kHz

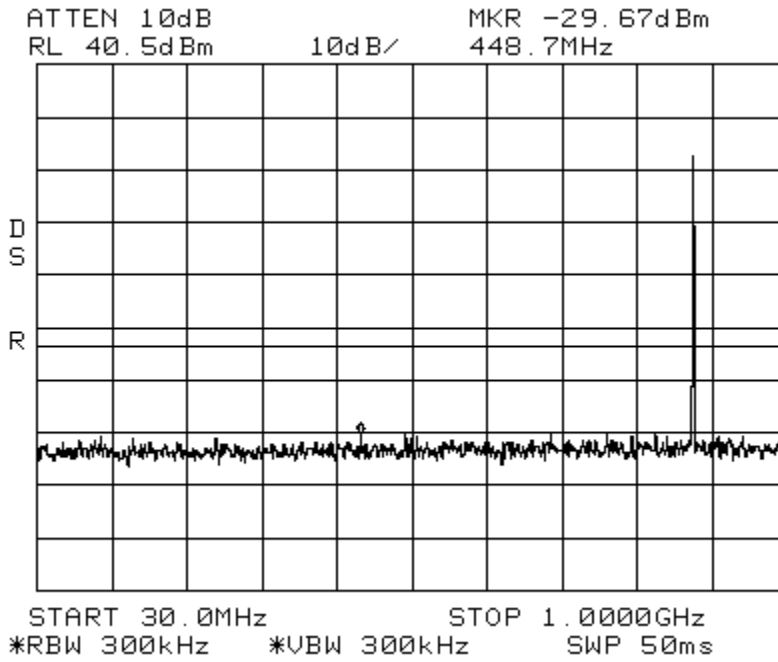

Conducted Emissions
Span: 1 GHz to 10 GHz

EDGE

Spectrum CELL
RBW/VBW: 1 MHz

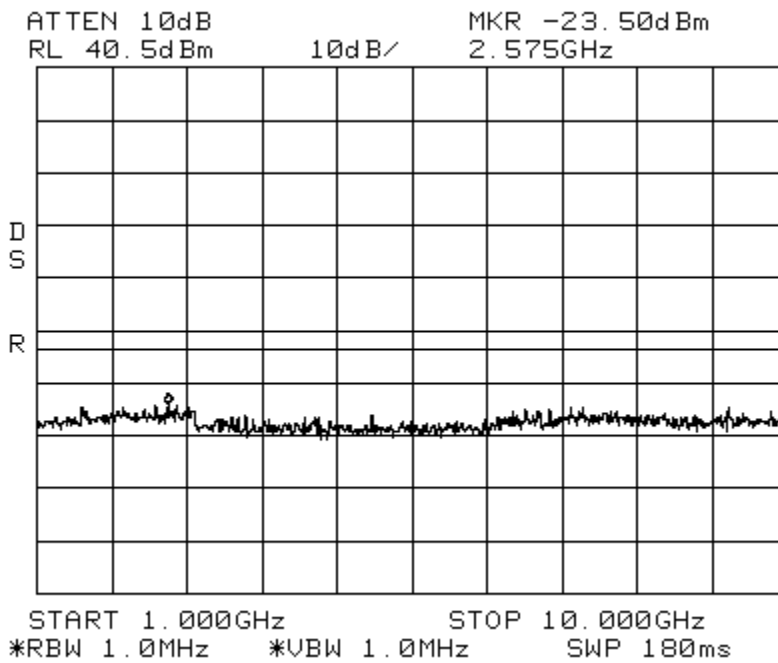

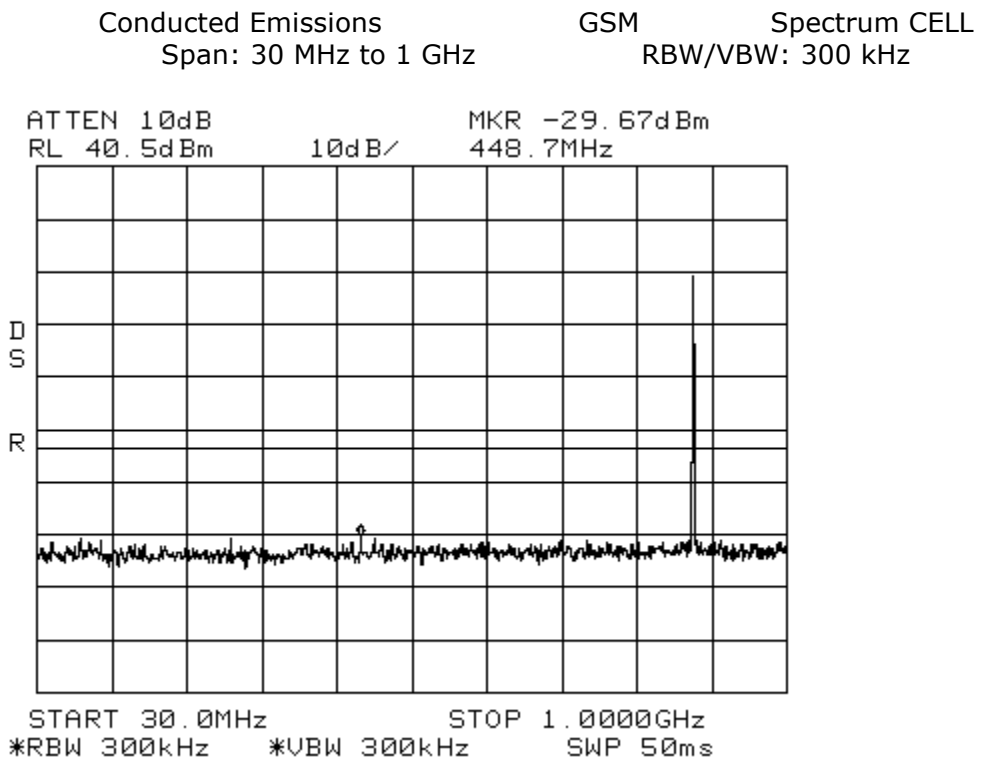
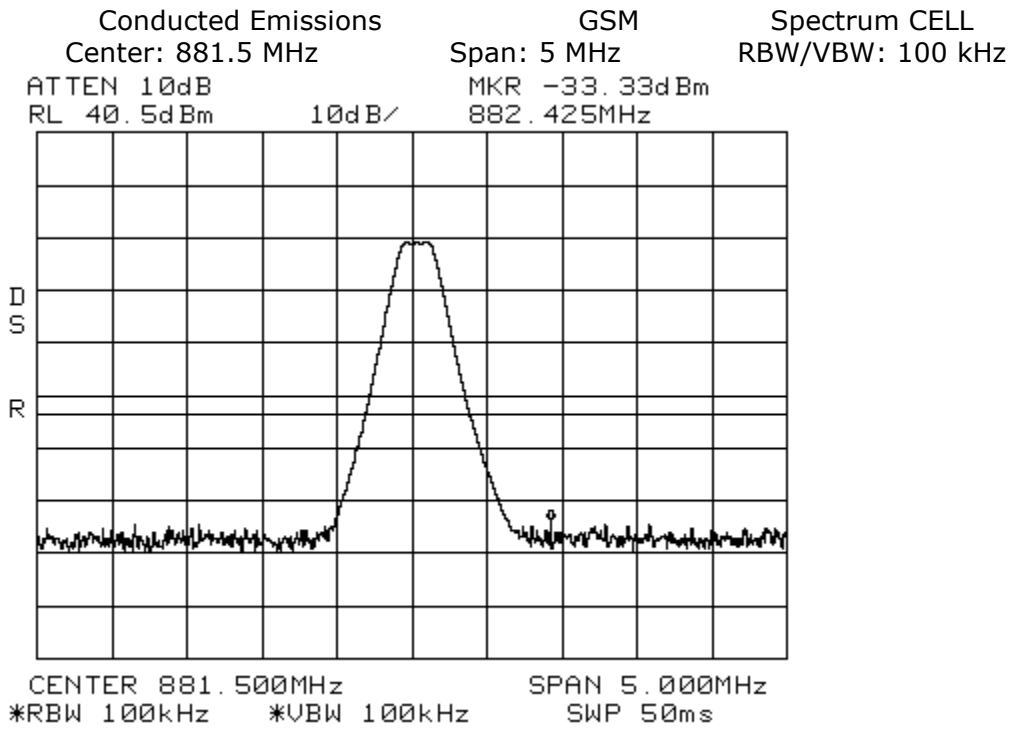

Conducted Emissions
Span: 1 GHz to 10 GHz

GSM
Spectrum CELL
RBW/VBW: 1 MHz

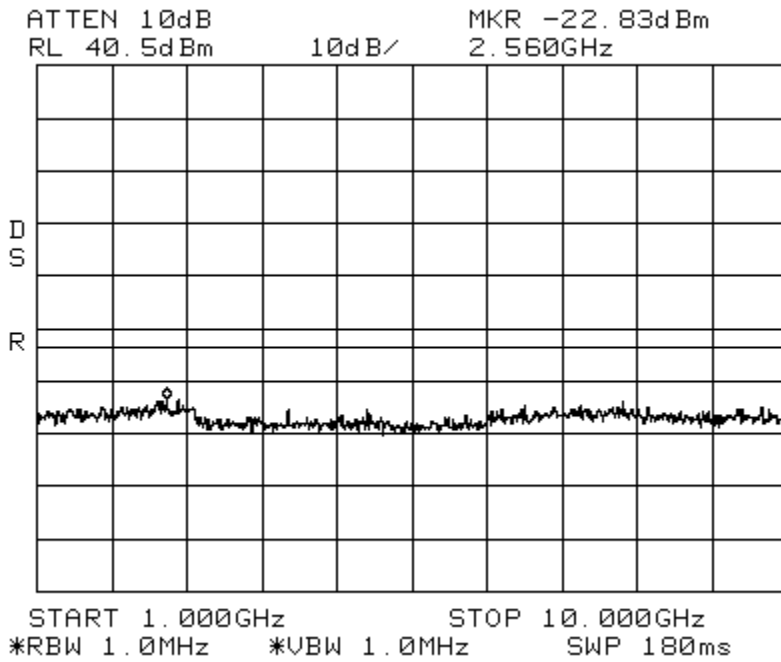

Conducted Emissions LTE 3 MHz Channel Bandwidth Spectrum CELL
Center: 881.5 MHz Span: 5 MHz RBW/VBW: 100 kHz

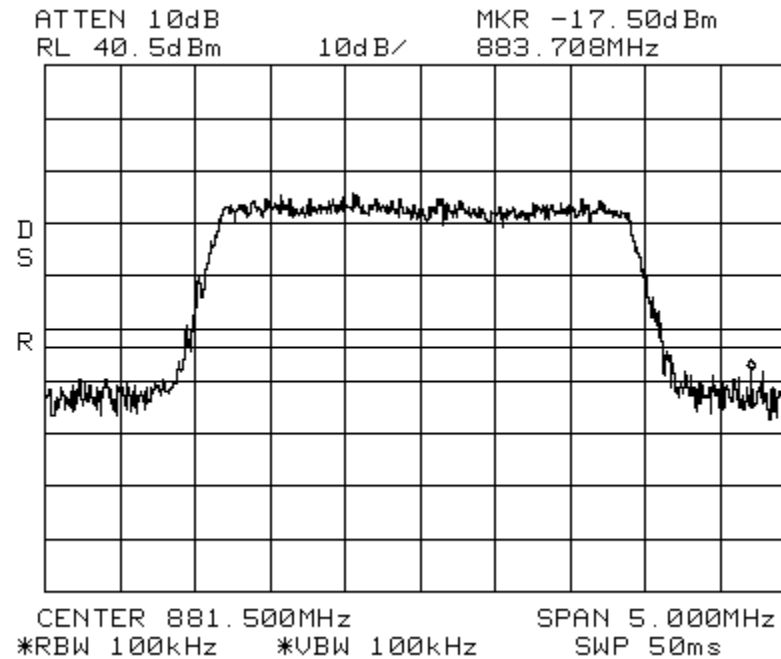

Conducted Emissions

LTE 3 MHz Channel Bandwidth

Spectrum CELL

Span: 30 MHz to 1 GHz

RBW/VBW: 300 kHz

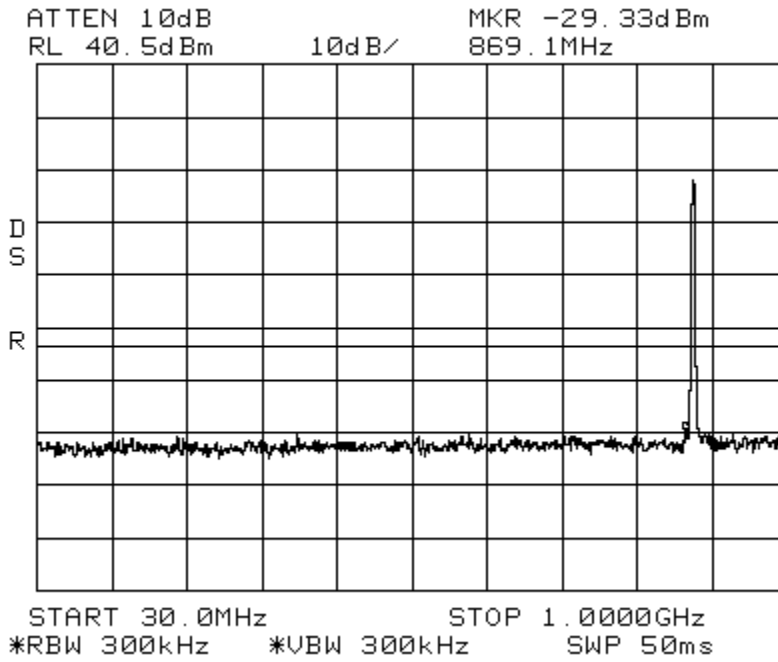

Conducted Emissions

LTE 3 MHz Channel Bandwidth

Spectrum CELL

Span: 1 GHz to 10 GHz

RBW/VBW: 1 MHz

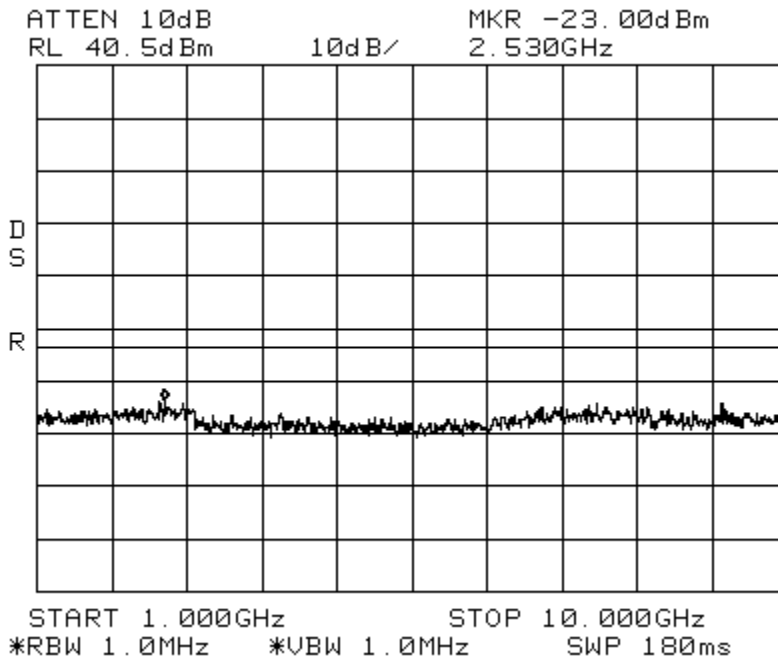

Conducted Emissions LTE 5 MHz Channel Bandwidth Spectrum CELL
Center: 881.5 MHz Span: 10 MHz RBW/VBW: 100 kHz

ATTEN 10dB MKR -18.50dBm
RL 40.5dBm 10dB/ 878.38MHz

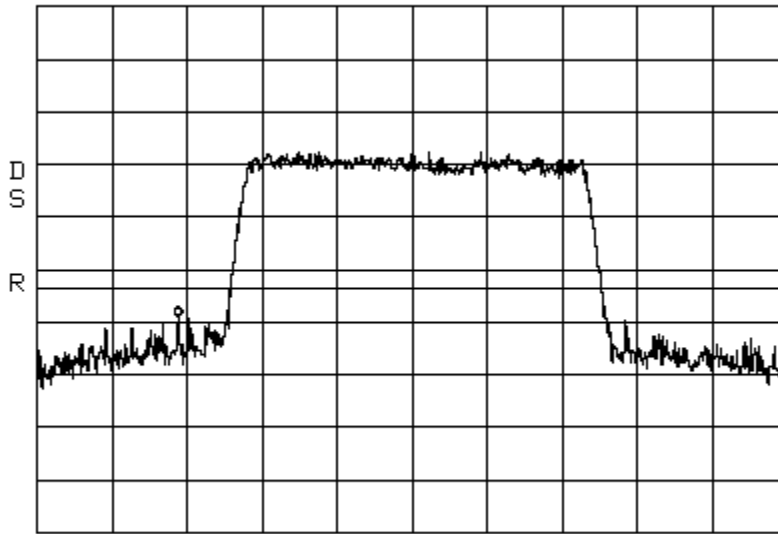

CENTER 881.50MHz SPAN 10.00MHz
*RBW 100kHz *VBW 100kHz SWP 50ms

Conducted Emissions LTE 5 MHz Channel Bandwidth Spectrum CELL
Span: 30 MHz to 1 GHz RBW/VBW: 300 kHz

ATTEN 10dB MKR -29.50dBm
RL 40.5dBm 10dB/ 830.3MHz

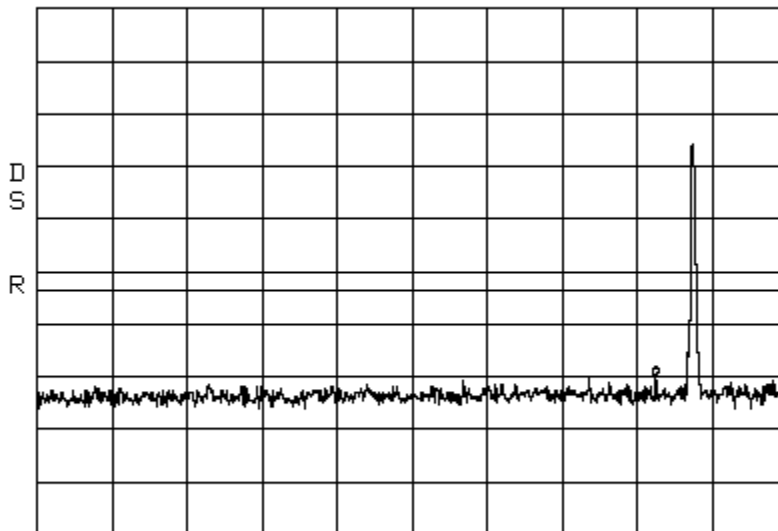

START 30.0MHz STOP 1.0000GHz
*RBW 300kHz *VBW 300kHz SWP 50ms

Conducted Emissions

LTE 5 MHz Channel Bandwidth

Spectrum CELL

Span: 1 GHz to 10 GHz

RBW/VBW: 1 MHz

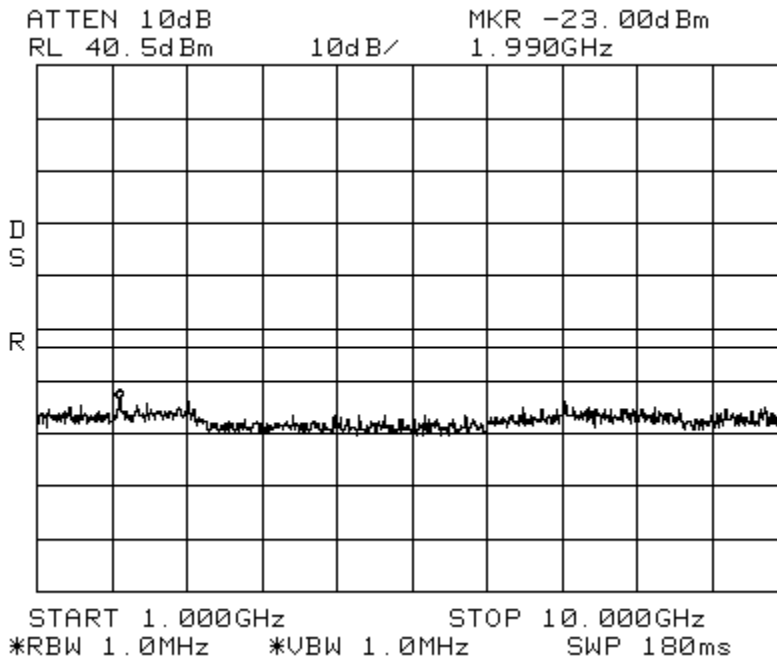

Conducted Emissions
Center: 881.5 MHz

LTE 10 MHz Channel Bandwidth
Span: 20MHz

Spectrum CELL

RBW/VBW: 100 kHz

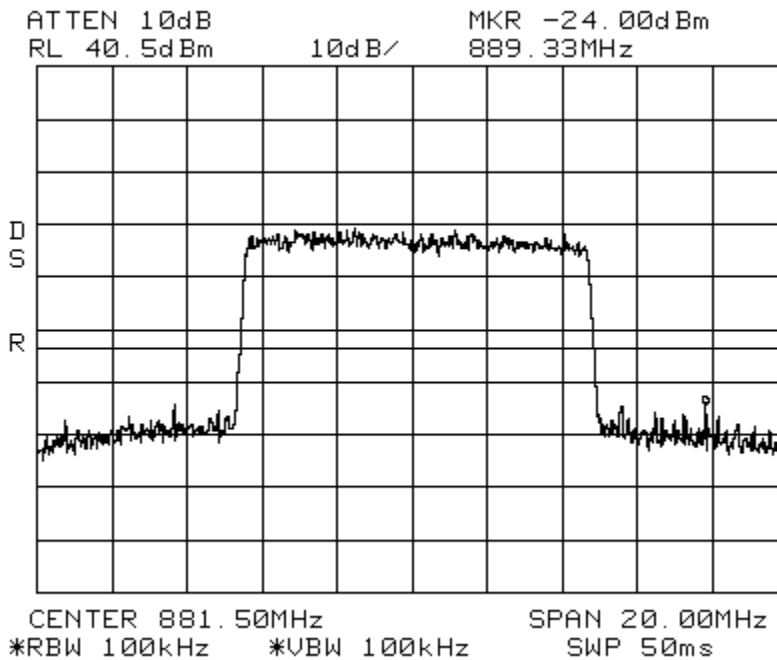

Conducted Emissions

LTE 10 MHz Channel Bandwidth
Span: 30 MHz to 1 GHz

Spectrum CELL

RBW/VBW: 300 kHz

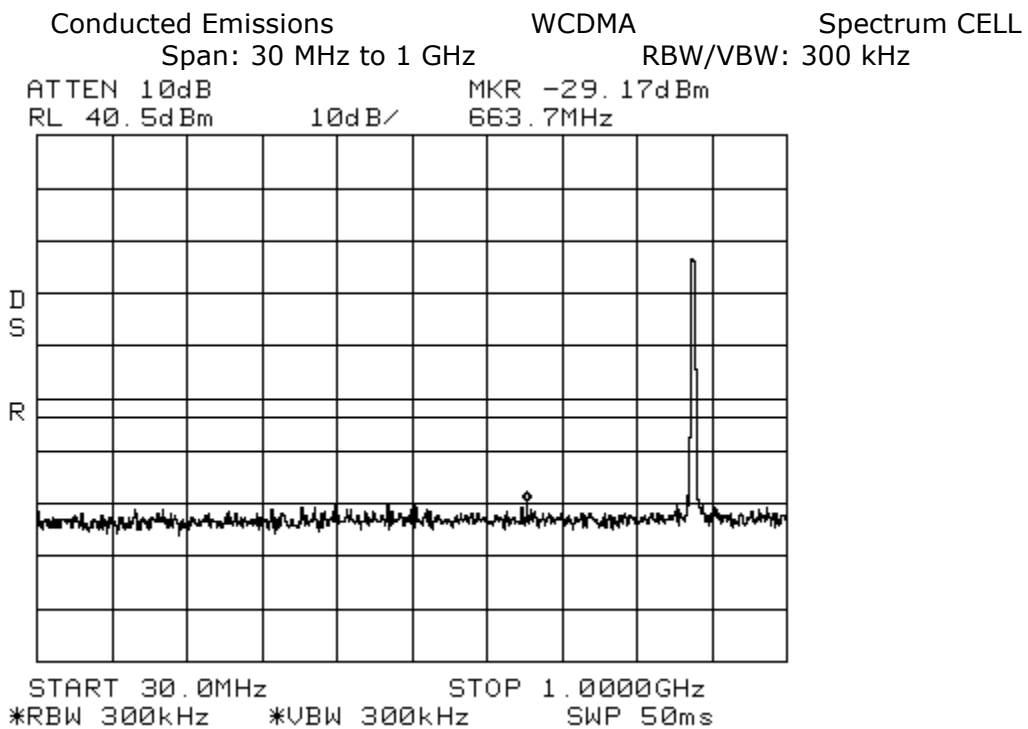
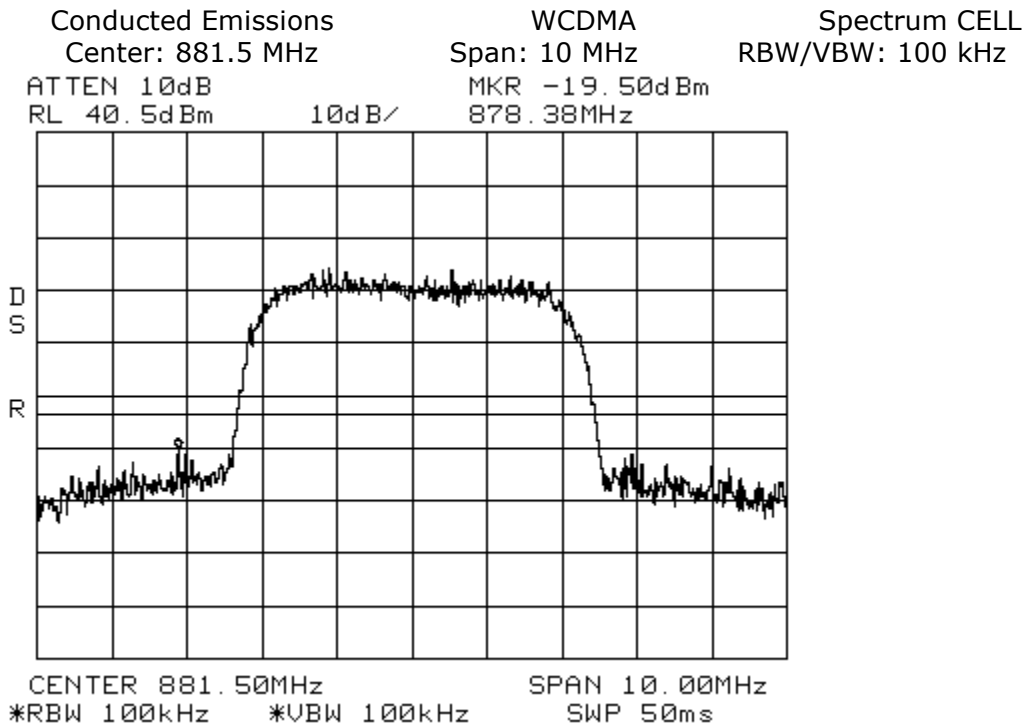

Conducted Emissions
Span: 1 GHz to 10 GHz

WCDMA

Spectrum CELL
RBW/VBW: 1 MHz

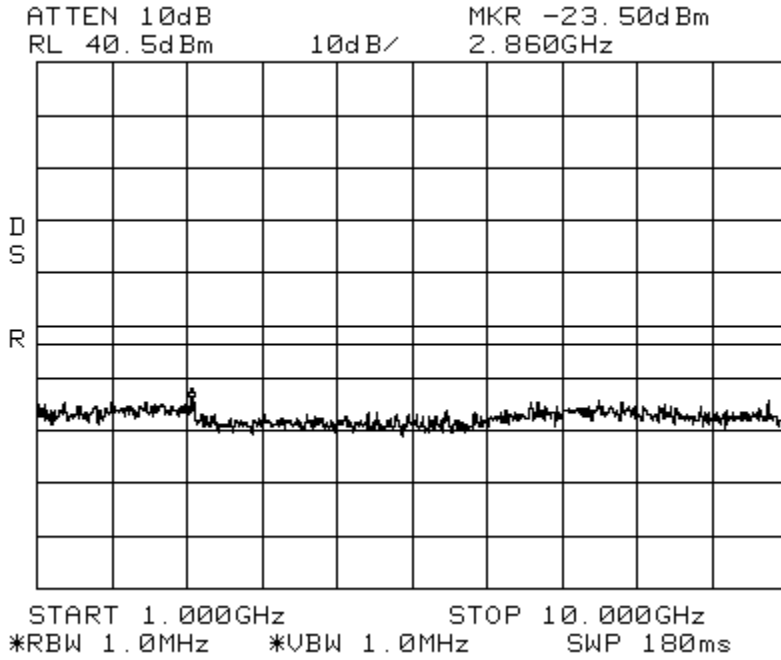

Conducted Emissions
Center: 1962.5 MHz Span: 5 MHz

CDMA

Spectrum PCS
RBW/VBW: 100 kHz

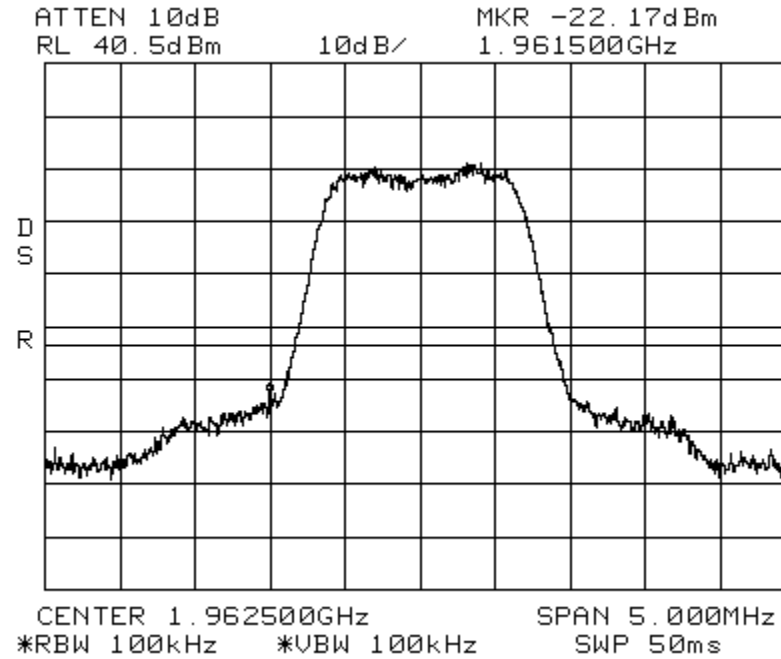

Conducted Emissions
Span: 30 MHz to 1 GHz

CDMA

Spectrum PCS
RBW/VBW: 300 kHz

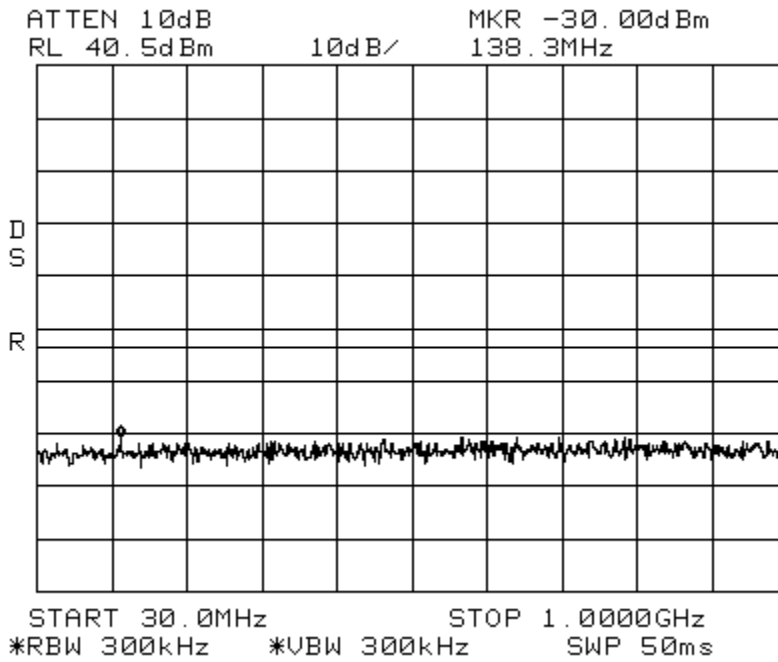

Conducted Emissions
Span: 1 GHz to 20 GHz

CDMA

Spectrum PCS
RBW/VBW: 1 MHz

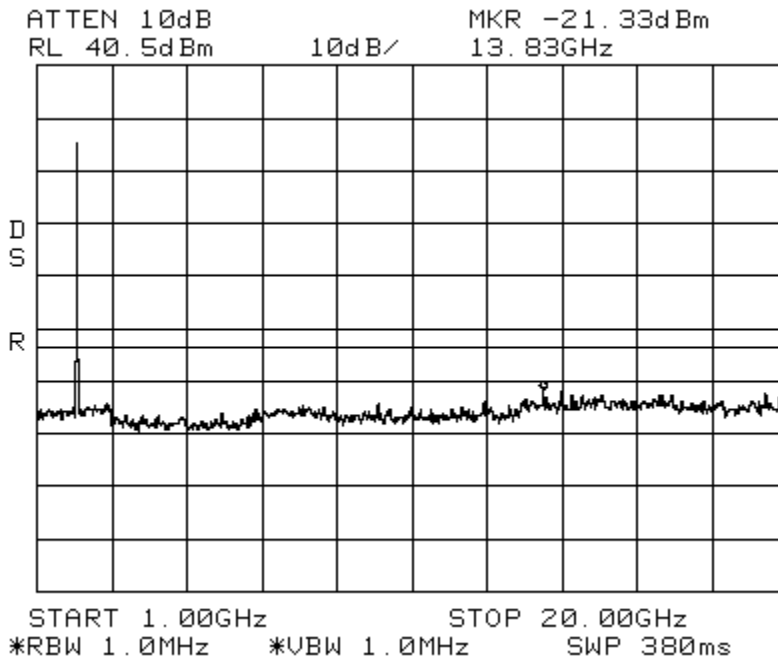

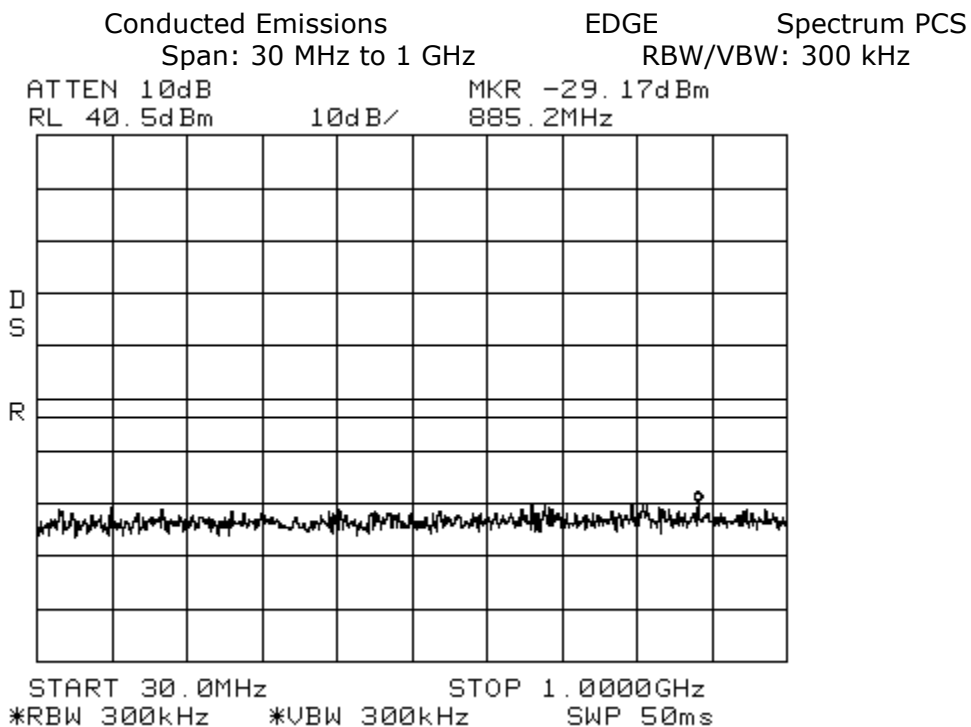
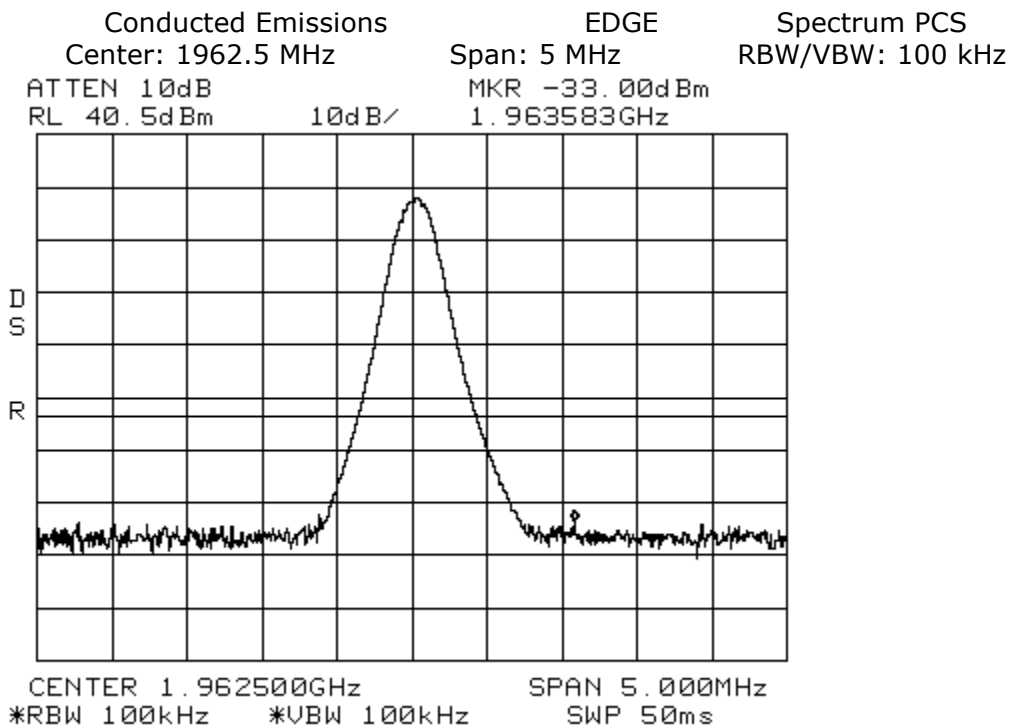

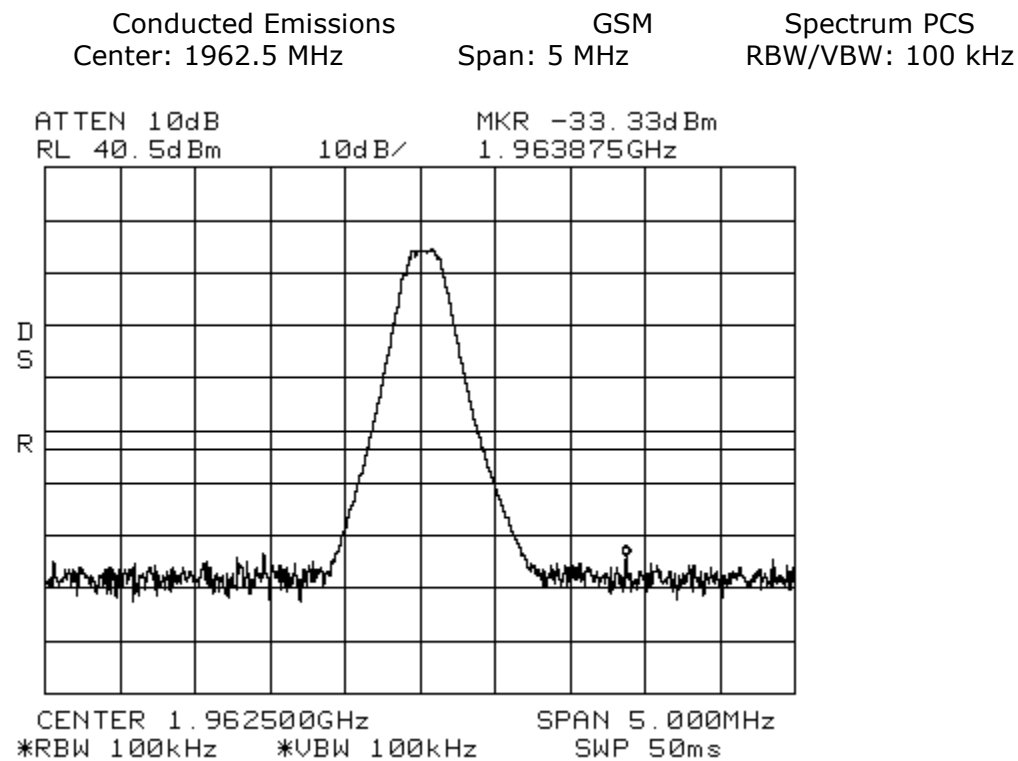
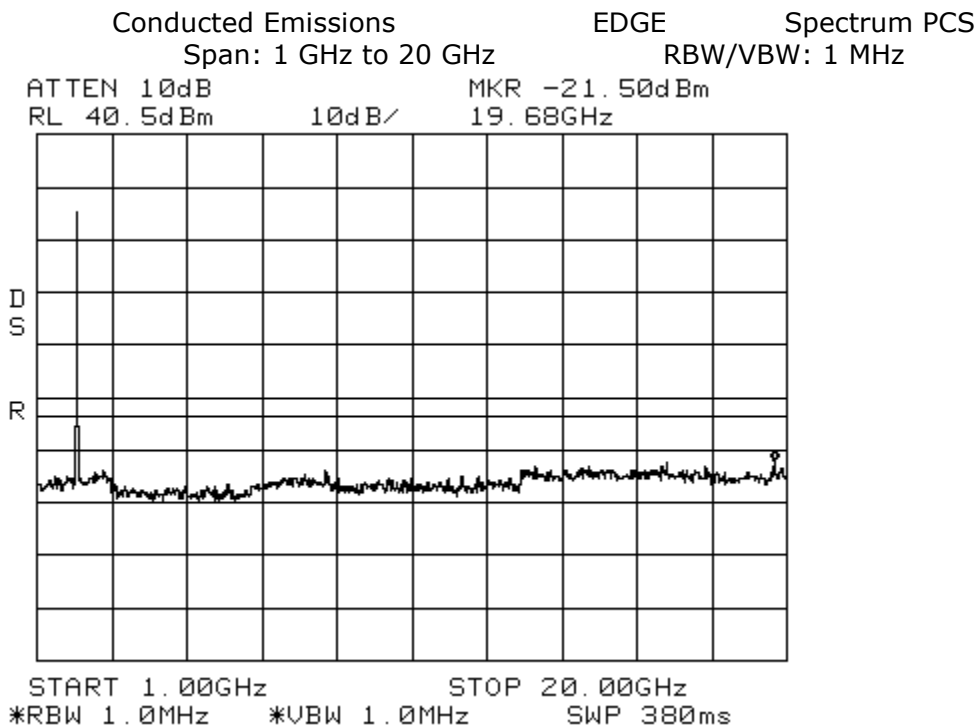

Conducted Emissions GSM Spectrum PCS
 Span: 30 MHz to 1 GHz RBW/VBW: 300 kHz

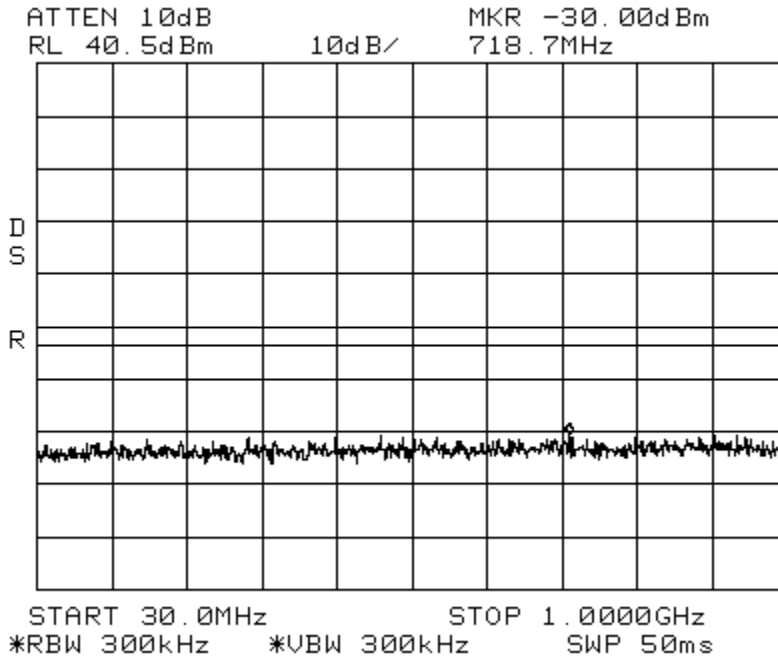

Conducted Emissions GSM Spectrum PCS
 Span: 1 GHz to 20 GHz RBW/VBW: 1 MHz

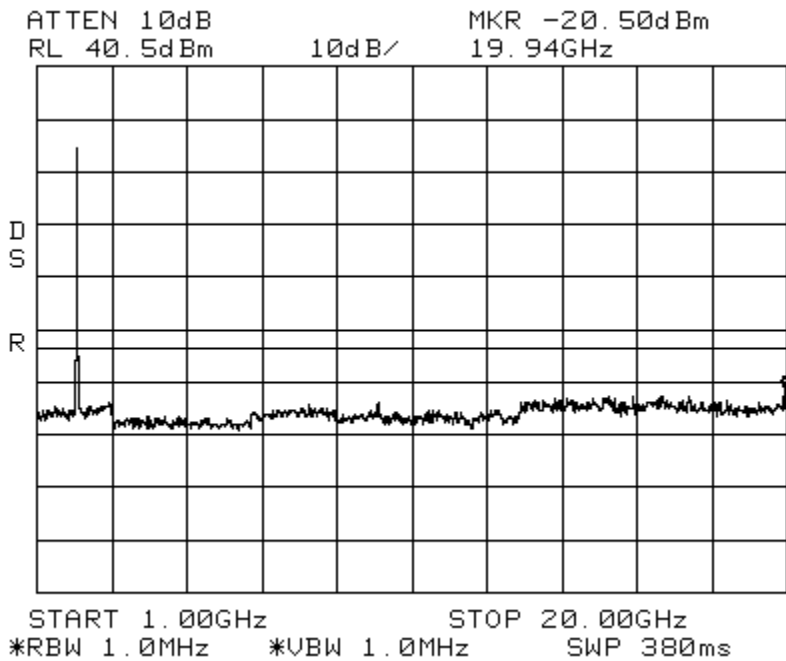

Conducted Emissions LTE 3 MHz Channel Bandwidth Spectrum PCS
 Center: 1962.5 MHz Span: 5 MHz RBW/VBW: 100 kHz

Conducted Emissions

LTE 3 MHz Channel Bandwidth

Spectrum PCS

Span: 1 GHz to 20 GHz

RBW/VBW: 1 MHz

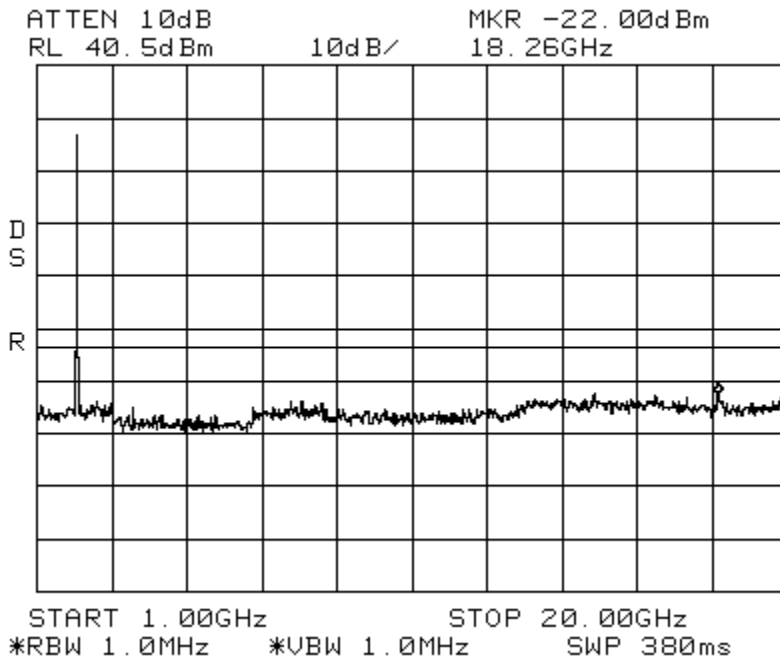

Conducted Emissions

LTE 5 MHz Channel Bandwidth

Spectrum PCS

Center: 1962.5 MHz

Span: 10 MHz

RBW/VBW: 100 kHz

ATTEN 10dB
RL 40.5dBm 10dB/
MKR -19.33dBm
1.96540GHz

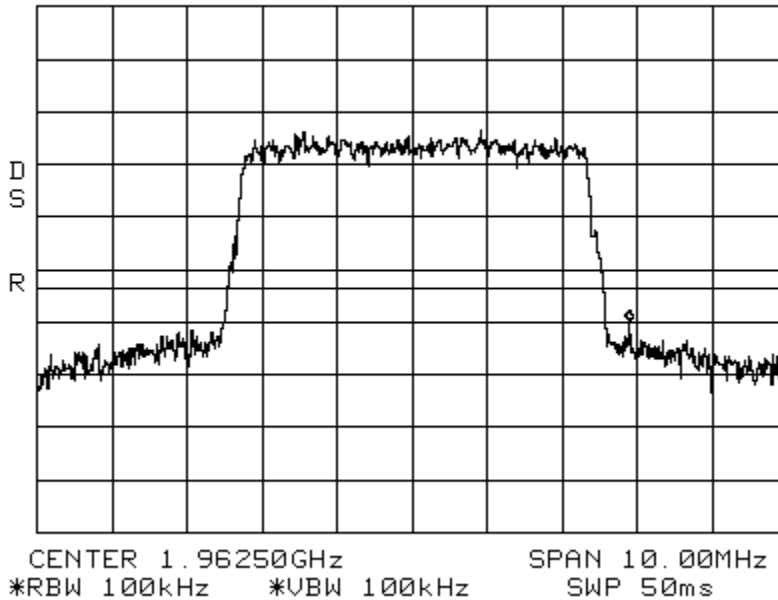

Conducted Emissions

LTE 5 MHz Channel Bandwidth

Spectrum PCS

Span: 30 MHz to 1 GHz

RBW/VBW: 300 kHz

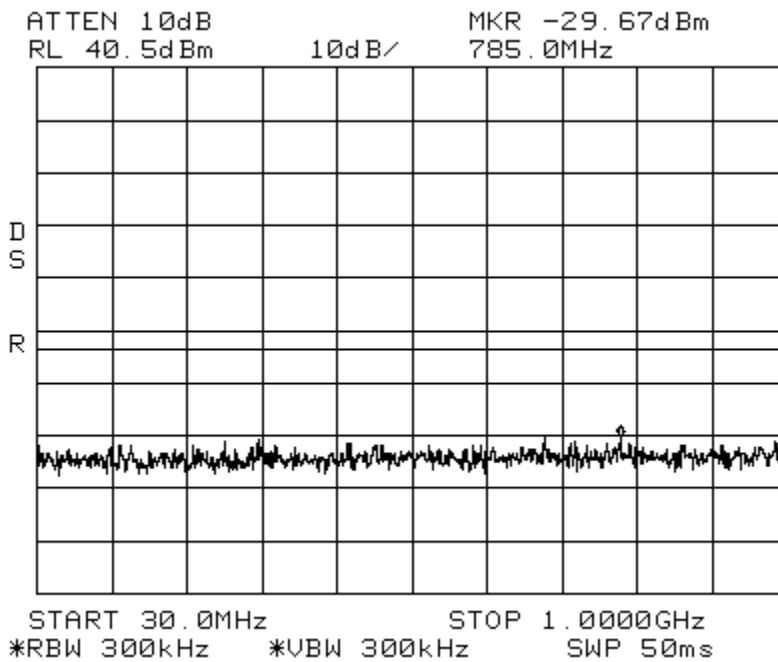

Conducted Emissions

LTE 5 MHz Channel Bandwidth

Spectrum PCS

Span: 1 GHz to 20 GHz

RBW/VBW: 1 MHz

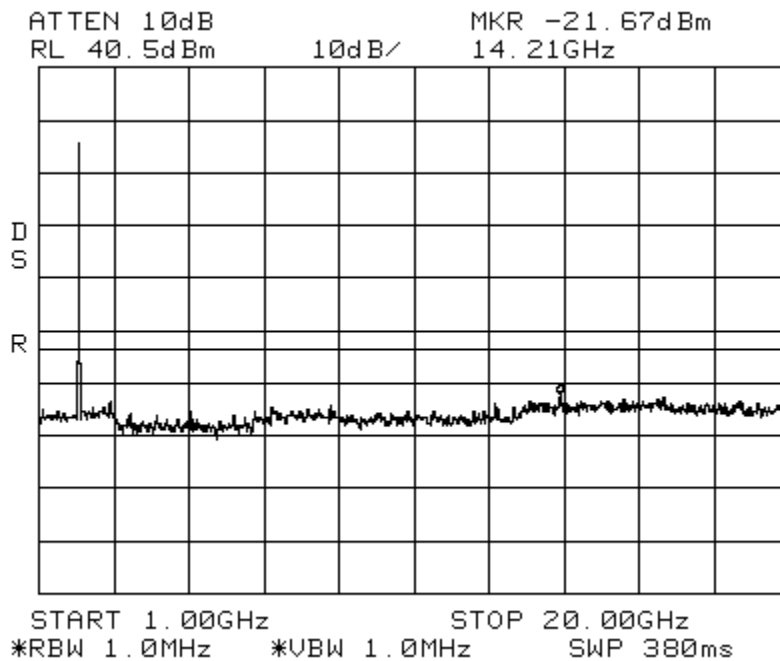

Conducted Emissions LTE 10 MHz Channel Bandwidth Spectrum PCS
Center: 1962.5 MHz Span: 20MHz RBW/VBW: 100 kHz

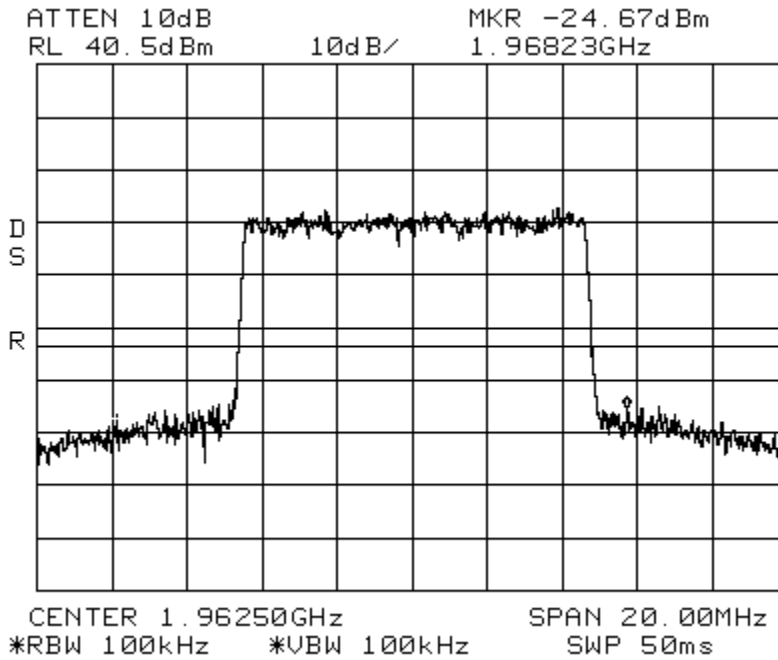

Conducted Emissions LTE 10 MHz Channel Bandwidth Spectrum PCS
Span: 30 MHz to 1 GHz RBW/VBW: 300 kHz

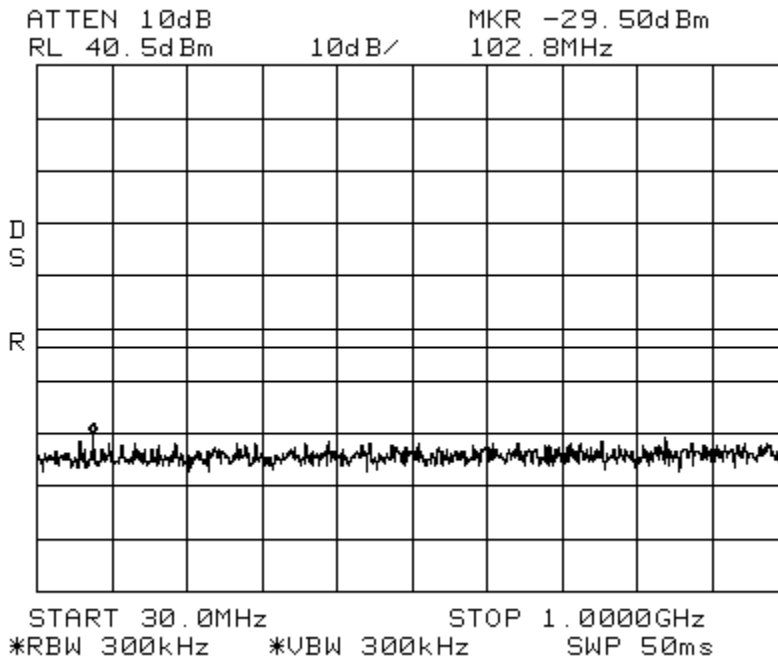

Conducted Emissions

LTE 10 MHz Channel Bandwidth

Spectrum PCS

Span: 1 GHz to 20 GHz

RBW/VBW: 1 MHz

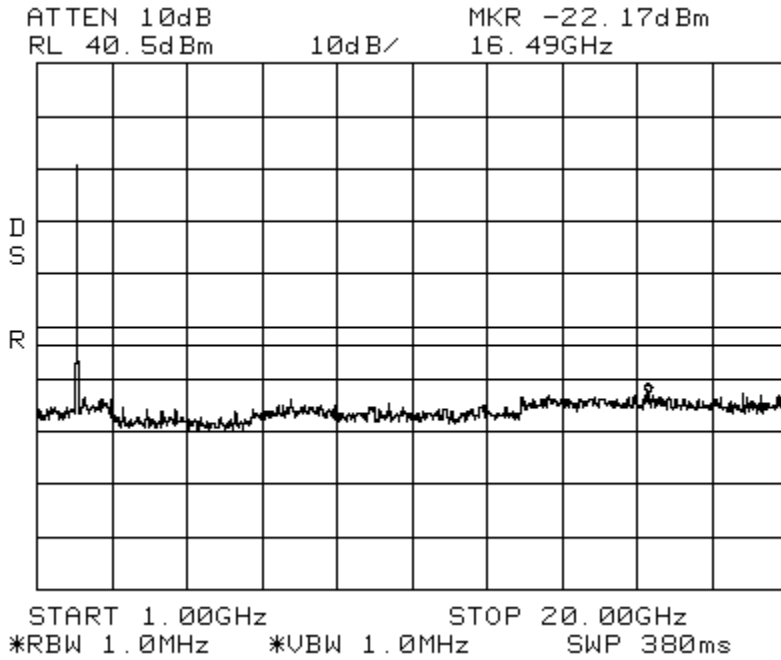

Conducted Emissions

LTE 15 MHz Channel Bandwidth

Spectrum PCS

Center: 881.5 MHz

Span: 30 MHz

RBW/VBW: 100 kHz

ATTEN 10dB
RL 40.5dBm
10dB/
MKR -24.83dBm
1.95280GHz

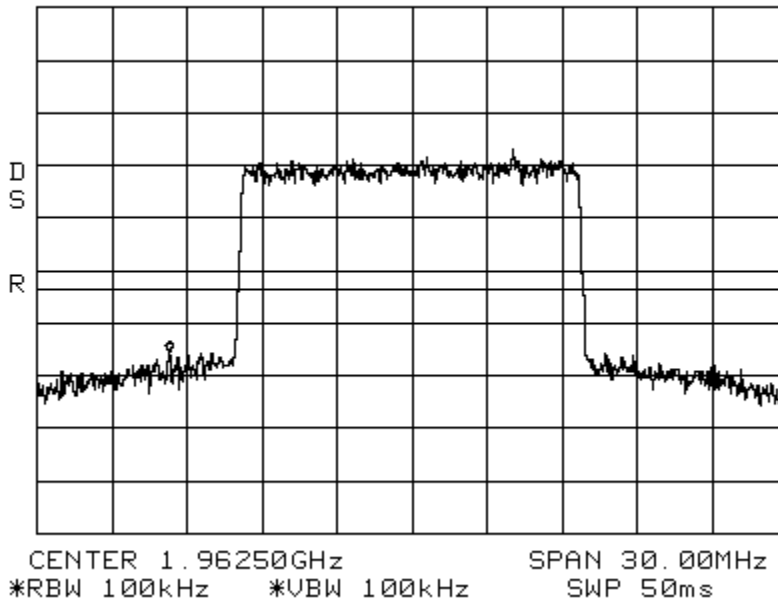

Conducted Emissions

LTE 15 MHz Channel Bandwidth

Spectrum PCS

Span: 30 MHz to 1 GHz

RBW/VBW: 300 kHz

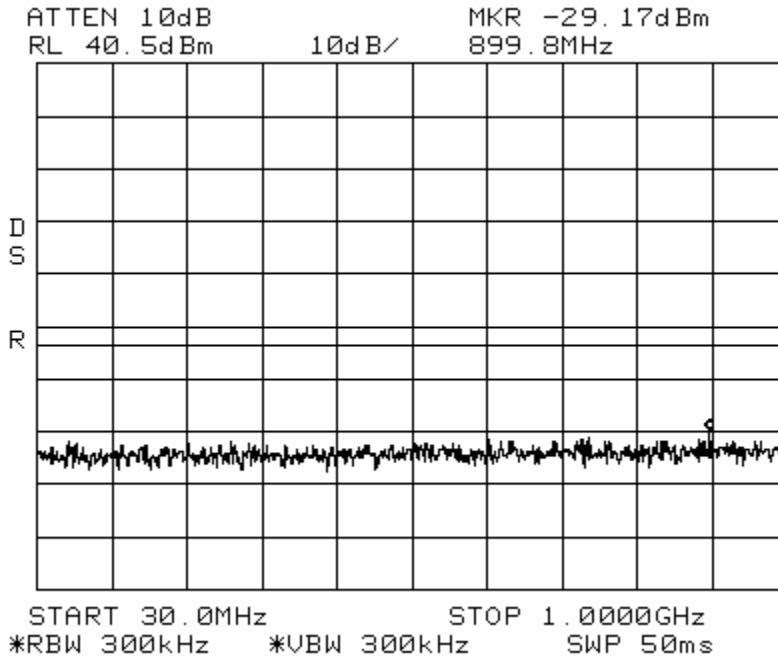

Conducted Emissions LTE 15 MHz Channel Bandwidth Spectrum PCS
 Span: 1 GHz to 20 GHz RBW/VBW: 1 MHz

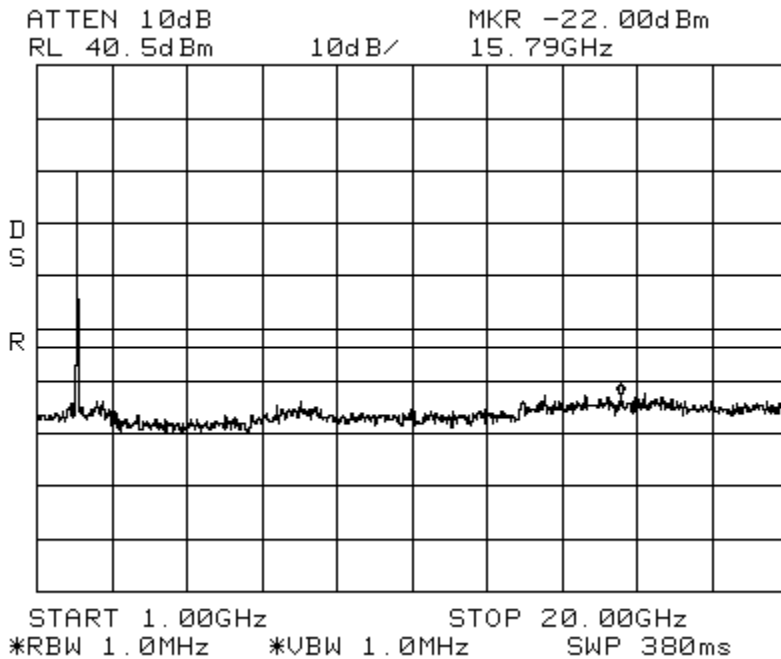

Conducted Emissions
Center: 1962.5 MHz

LTE 20 MHz Channel Bandwidth
Span: 50MHz

Spectrum PCS
RBW/VBW: 100 kHz

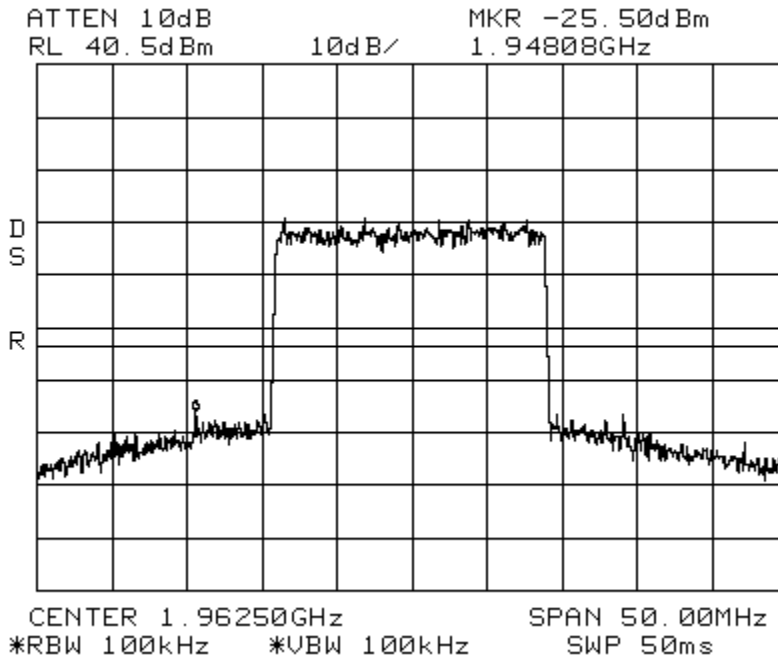

Conducted Emissions
Span: 30 MHz to 1 GHz

LTE 20 MHz Channel Bandwidth
RBW/VBW: 300 kHz

Spectrum PCS

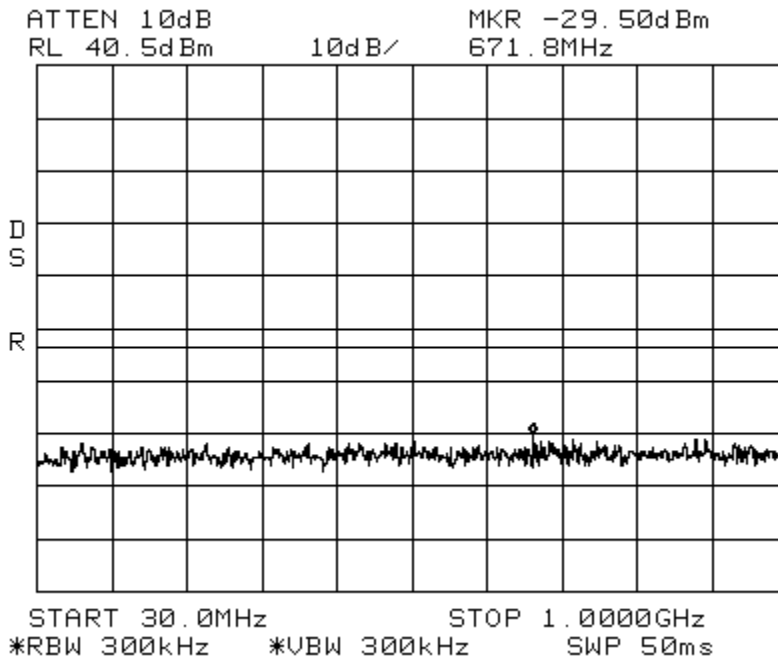

Conducted Emissions

LTE 20 MHz Channel Bandwidth

Spectrum PCS

Span: 1 GHz to 20 GHz

RBW/VBW: 1 MHz

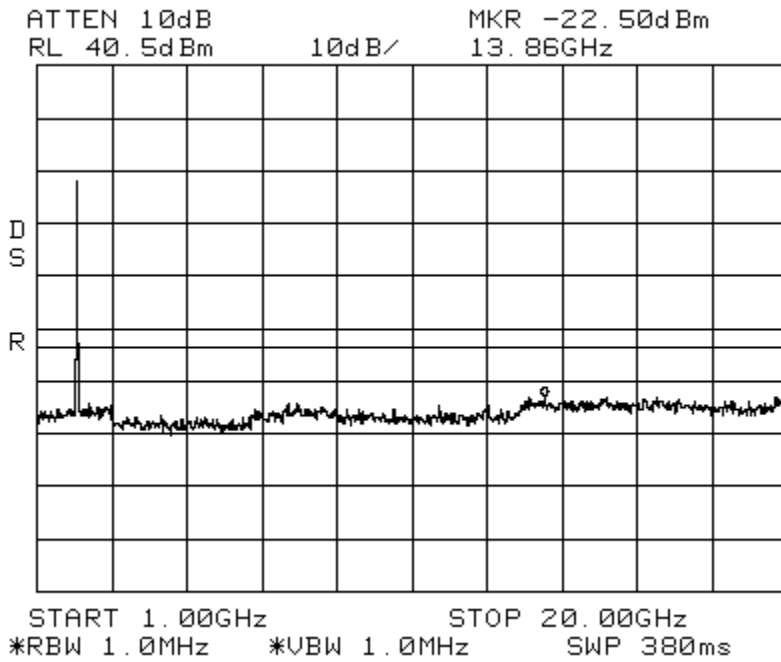

Conducted Emissions

WCDMA

Spectrum PCS

Center: 1962.5 MHz

Span: 10 MHz

RBW/VBW: 100 kHz

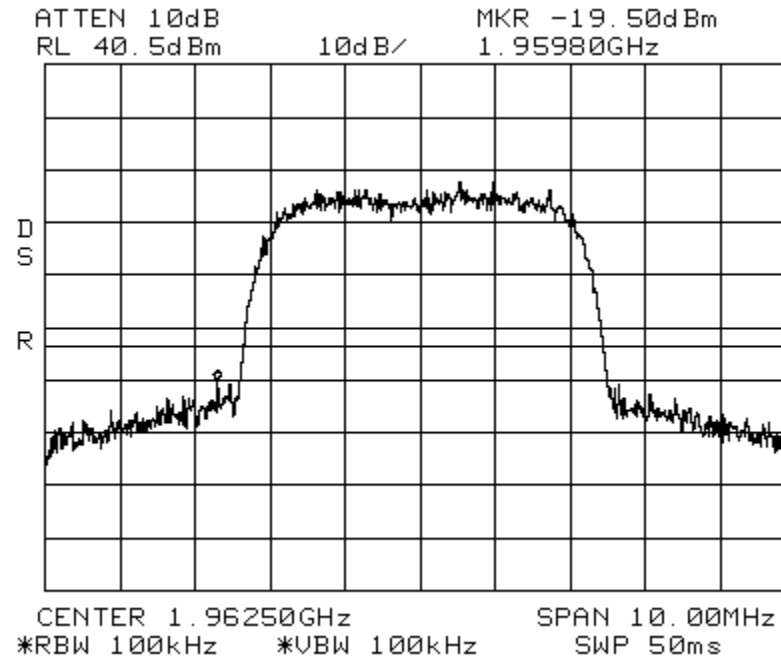

Conducted Emissions

WCDMA

Spectrum PCS

Span: 30 MHz to 1 GHz

RBW/VBW: 300 kHz

Band_Edge CDMA Spectrum CELL
Center: 869.73 MHz Span: 5 MHz RBW: 10 kHz VBW: 10 kHz

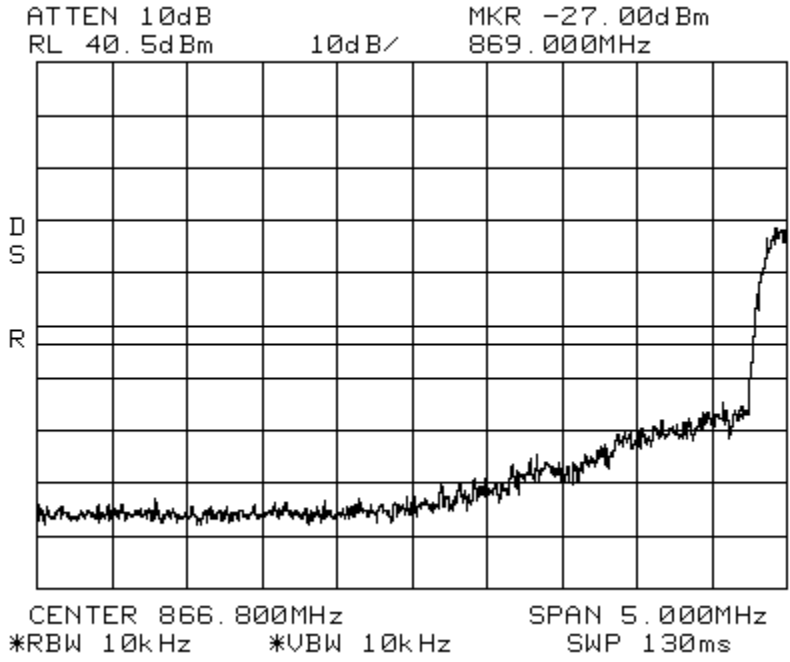

Band_Edge CDMA Spectrum CELL
Center: 893.19 MHz Span: 5 MHz RBW: 10 kHz VBW: 10 kHz

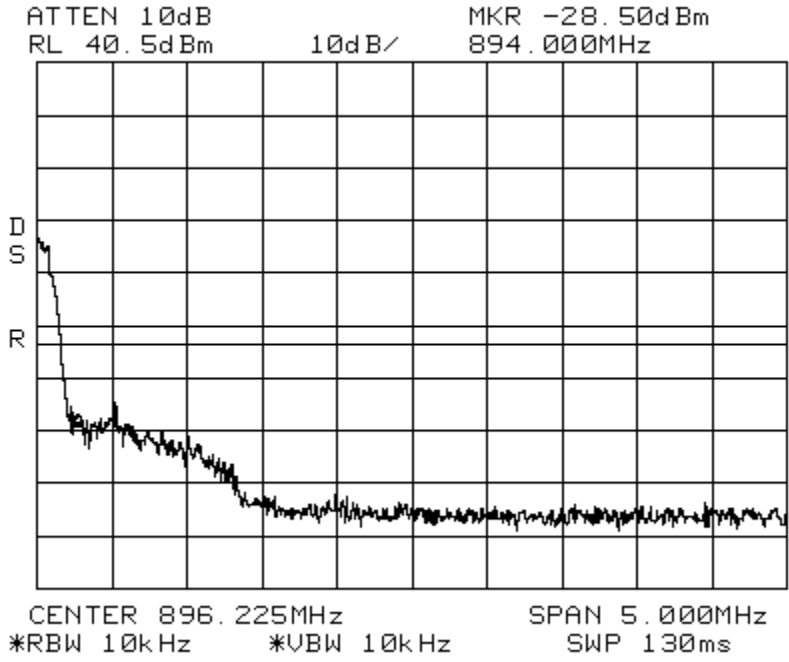

Band_Edge EDGE Spectrum CELL
 Center: 869.2 MHz Span: 2 MHz RBW: 3 kHz VBW: 10 kHz
 ATTN 10dB MKR -23.00dBm
 RL 40.5dBm 10dB/ 869.000MHz

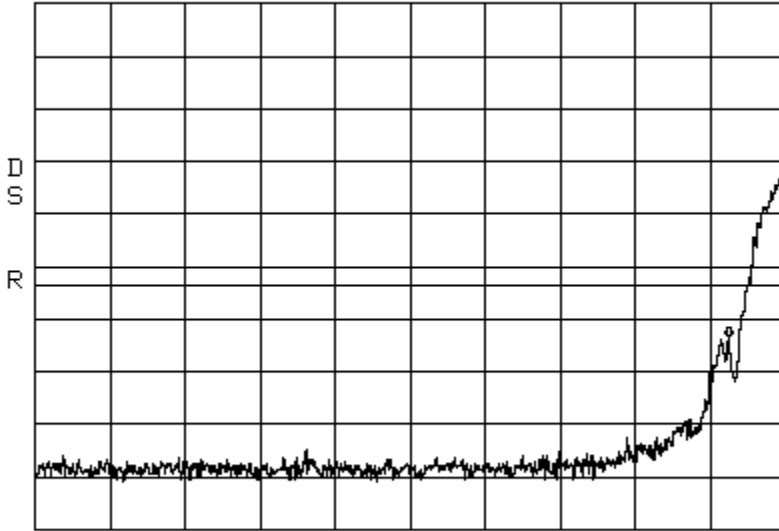

CENTER 868.150MHz SPAN 2.000MHz
 *RBW 3.0kHz *VBW 10kHz SWP 560ms

Band_Edge EDGE Spectrum CELL
 Center: 893.8 MHz Span: 2 MHz RBW: 3 kHz VBW: 10 kHz

ATTN 10dB MKR -29.67dBm
 RL 40.5dBm 10dB/ 894.000MHz

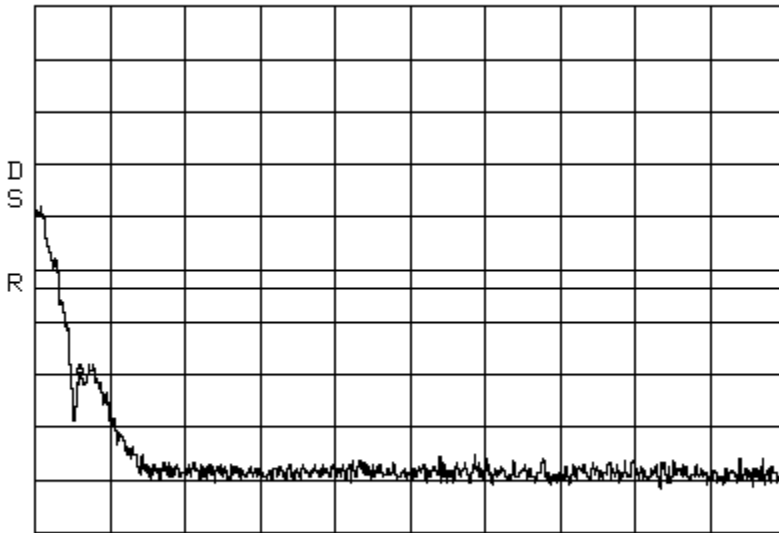

CENTER 894.880MHz SPAN 2.000MHz
 *RBW 3.0kHz *VBW 10kHz SWP 560ms

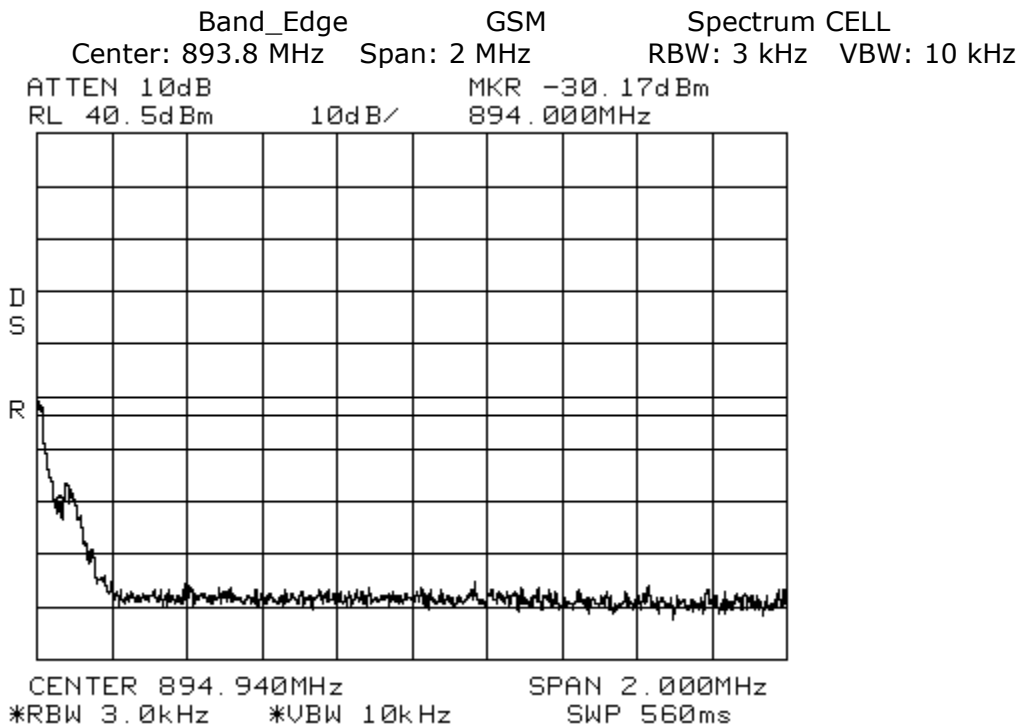
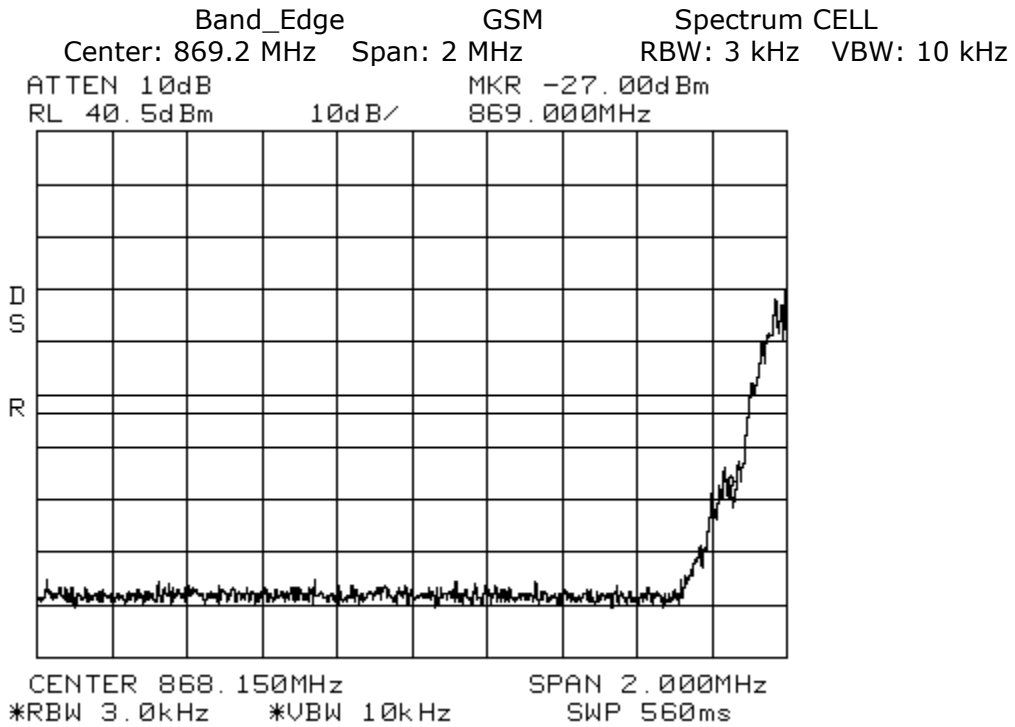

Band_Edge LTE 3 MHz Channel Bandwidth Spectrum CELL
Center: 870.5MHz Span: 5 MHz RBW: 30 kHz VBW: 100 kHz
ATTEN 10dB MKR -24.33dBm
RL 40.5dBm 10dB/ 869.000MHz

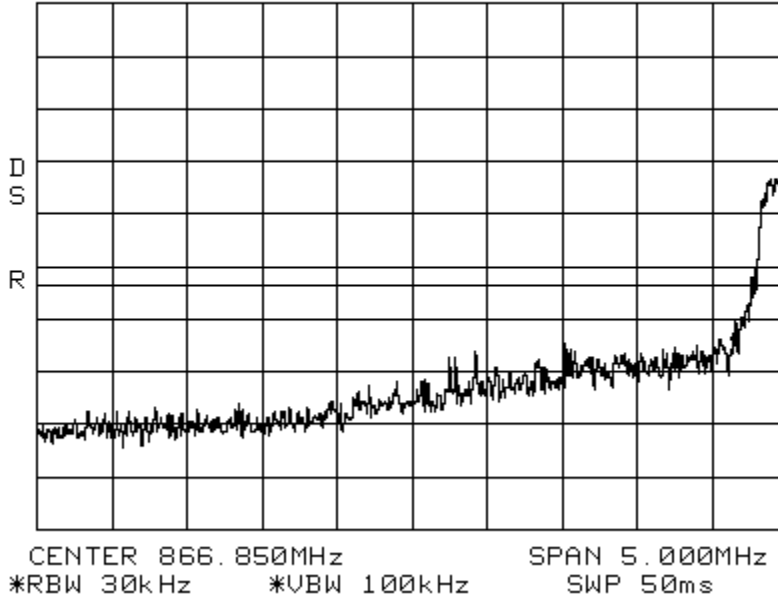

Band_Edge LTE 3MHz Channel Bandwidth Spectrum CELL
Center: 892.5MHz Span: 5 MHz RBW: 30 kHz VBW: 100 kHz
ATTEN 10dB MKR -21.50dBm
RL 40.5dBm 10dB/ 894.000MHz

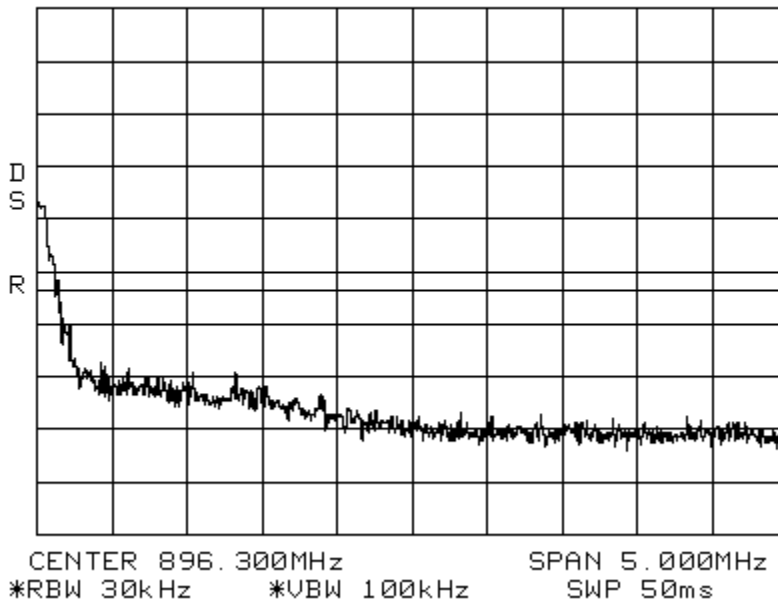

Band_Edge LTE 5 MHz Channel Bandwidth Spectrum CELL
Center: 871.5MHz Span: 10 MHz RBW: 30 kHz VBW: 100 kHz
ATTEN 10dB MKR -28.83dBm
RL 40.5dBm 10dB/ 869.00MHz

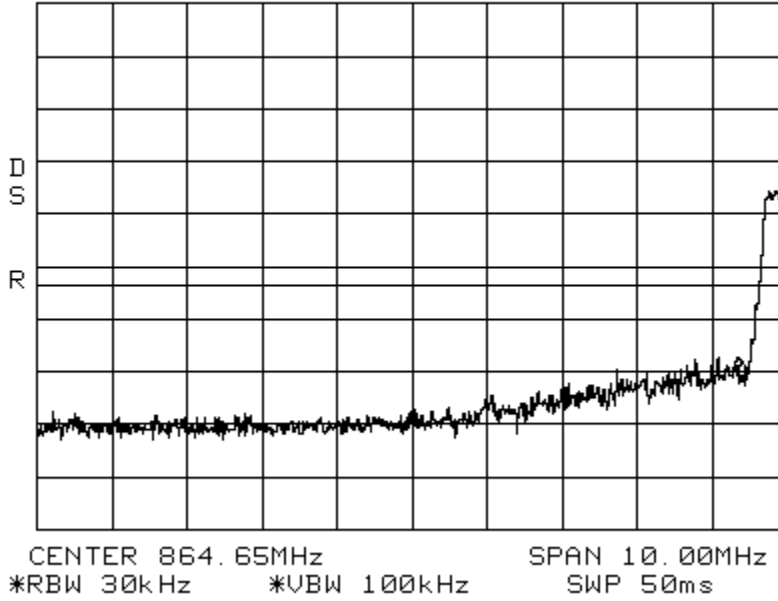

Band_Edge LTE 5 MHz Channel Bandwidth Spectrum CELL
Center: 891.5MHz Span: 10 MHz RBW: 30 kHz VBW: 100 kHz
ATTEN 10dB MKR -32.50dBm
RL 40.5dBm 10dB/ 894.00MHz

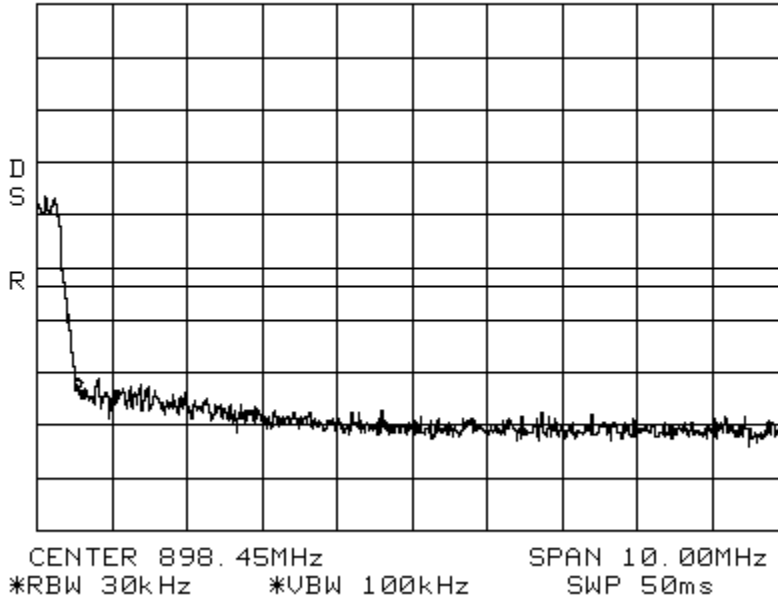

Band_Edge LTE 10 MHz Channel Bandwidth
Center: 874MHz Span: 20 MHz RBW: 100 kHz
ATTEN 10dB MKR -30.00dBm
RL 40.5dBm 10dB/ 869.00MHz

Spectrum CELL
VBW: 100 kHz

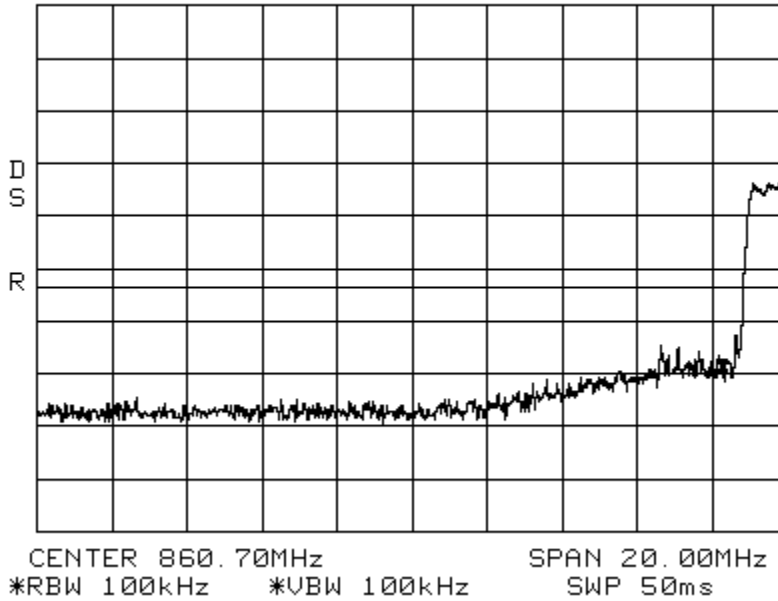

Band_Edge LTE 10 MHz Channel Bandwidth
Center: 889MHz Span: 20 MHz RBW: 100 kHz

Spectrum CELL
VBW: 100 kHz

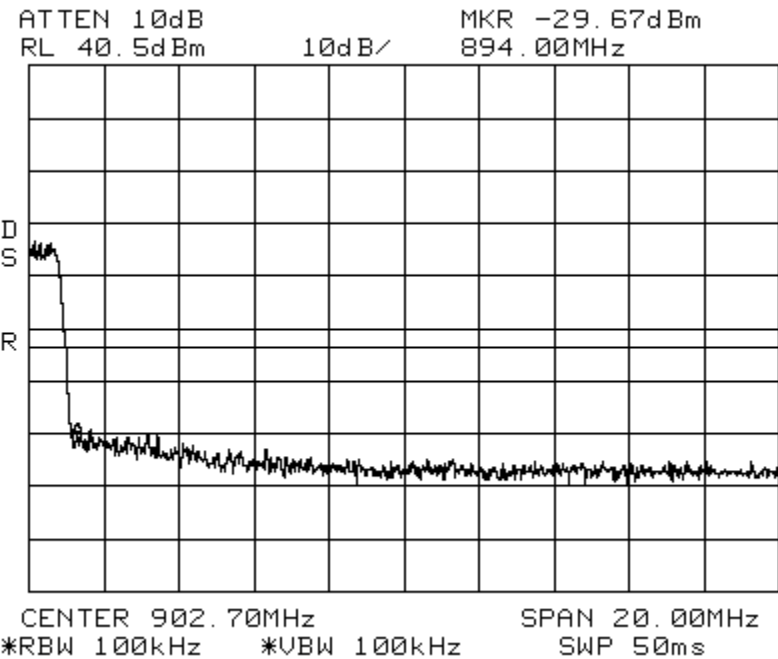

Band_Edge WCDMA Spectrum CELL
 Center: 871.6 MHz Span: 10 MHz RBW: 30 kHz VBW: 100 kHz
 ATTEN 10dB MKR -24.17dBm
 RL 40.5dBm 10dB/ 869.00MHz

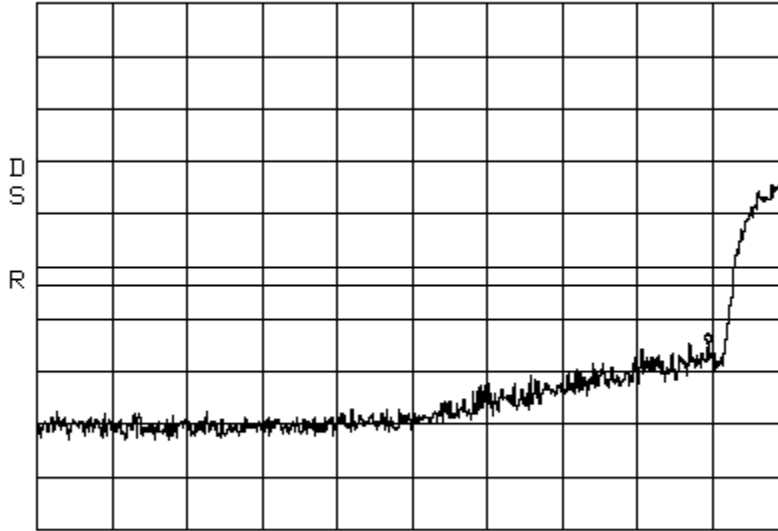

CENTER 865.05MHz SPAN 10.00MHz
 *RBW 30kHz *VBW 100kHz SWP 50ms

Band_Edge WCDMA Spectrum CELL
 Center: 891.4 MHz Span: 10MHz RBW: 30 kHz VBW: 100 kHz

ATTEN 10dB MKR -31.33dBm
 RL 40.5dBm 10dB/ 894.00MHz

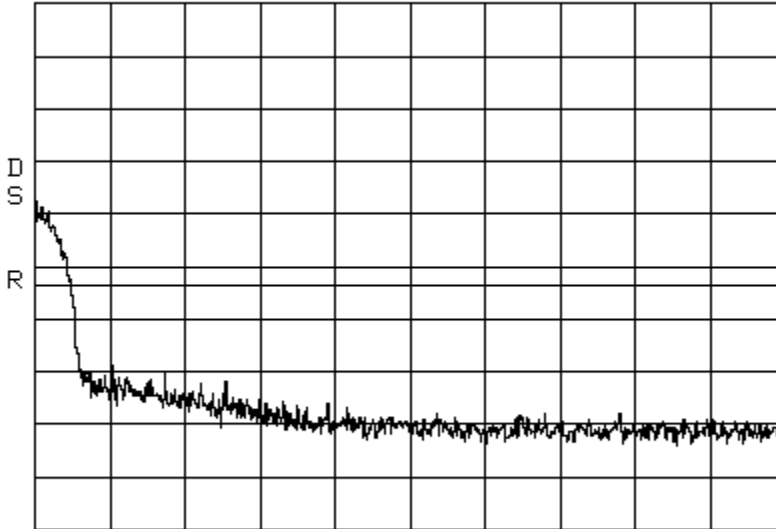

CENTER 898.30MHz SPAN 10.00MHz
 *RBW 30kHz *VBW 100kHz SWP 50ms

Band_Edge CDMA Spectrum PCS Path 1
Center: 1930.75 MHz Span: 10 MHz RBW: 10 kHz VBW: 10 kHz

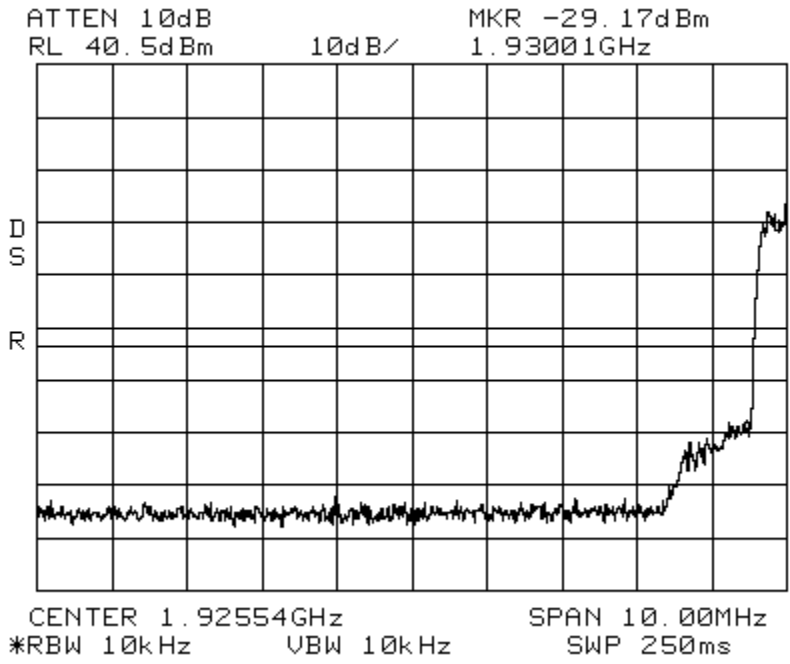

Band_Edge CDMA Spectrum PCS Path 1
Center: 1994.25 MHz Span: 10 MHz RBW: 10 kHz VBW: 10 kHz

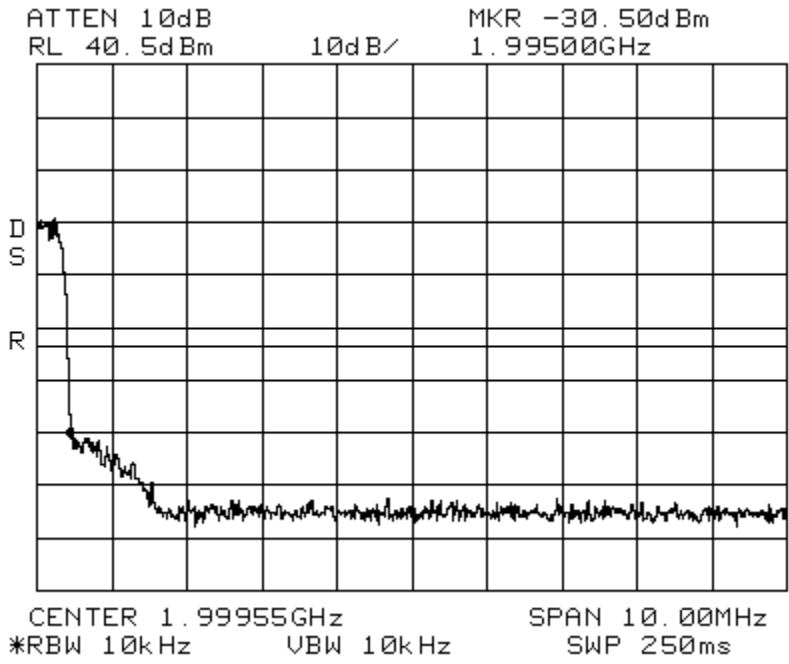

Band_Edge EDGE Spectrum PCS Path 1
Center: 1930.2 MHz Span: 1.5MHz RBW: 3 kHz VBW: 10 kHz
ATTEN 10dB MKR -29.50dBm
RL 40.5dBm 10dB/ 1.930000GHz

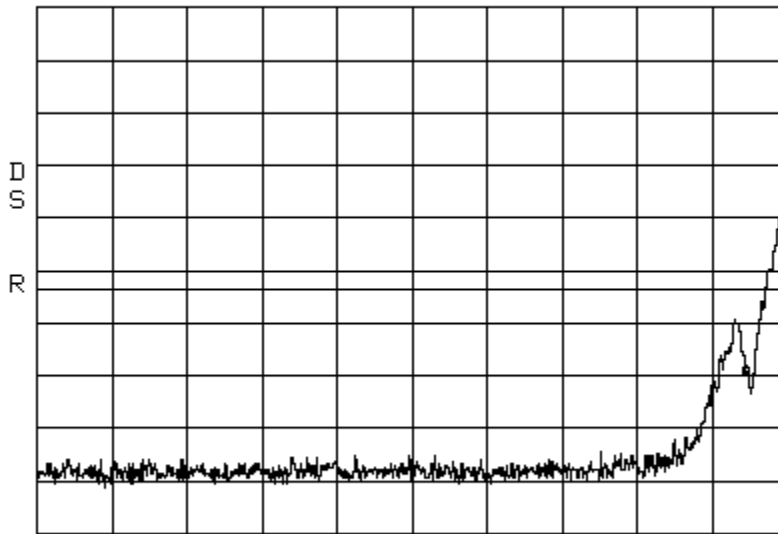

CENTER 1.929333GHz SPAN 1.500MHz
*RBW 3.0kHz *VBW 10kHz SWP 420ms

Band_Edge EDGE Spectrum PCS Path 1
Center: 1994.8 MHz Span: 1.5MHz RBW: 3 kHz VBW: 10 kHz

ATTEN 10dB MKR -28.83dBm
RL 40.5dBm 10dB/ 1.995000GHz

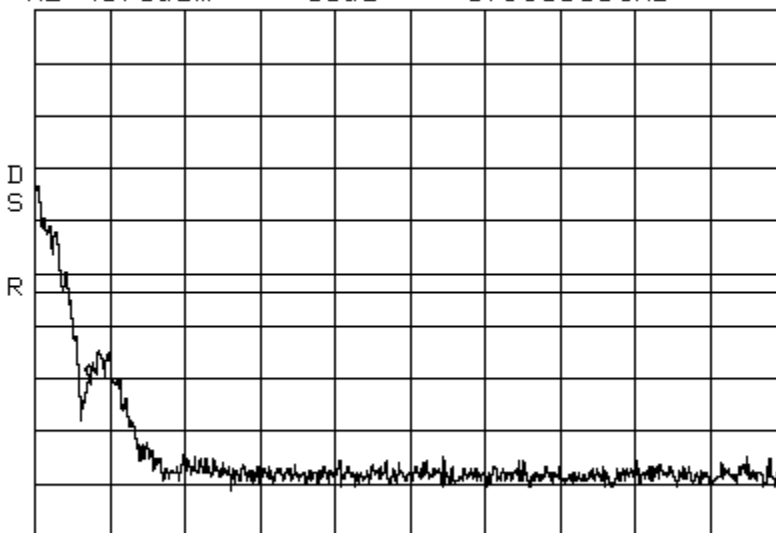

CENTER 1.995643GHz SPAN 1.500MHz
*RBW 3.0kHz *VBW 10kHz SWP 420ms

Band_Edge GSM Spectrum PCS Path 1
Center: 1930.2 MHz Span: 1.5MHz RBW: 3 kHz VBW: 10 kHz

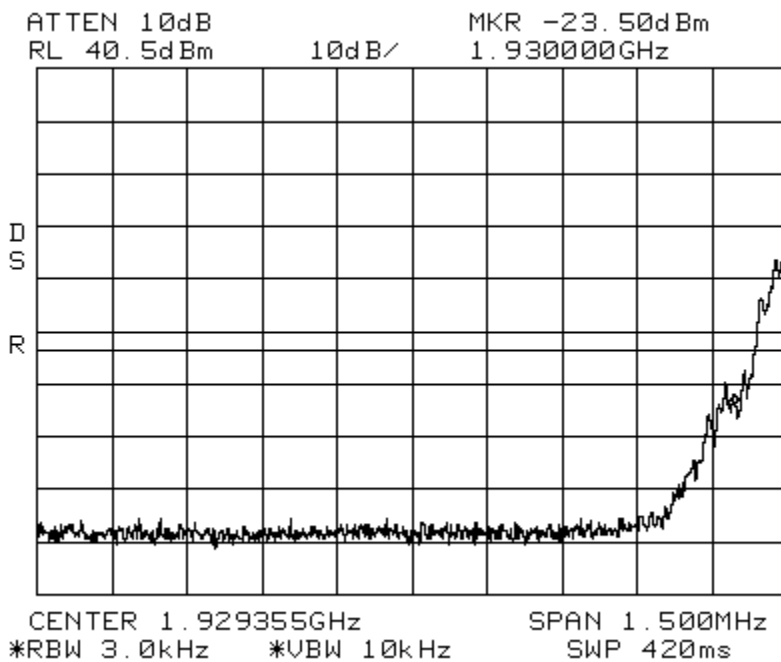

Band_Edge GSM Spectrum PCS Path 1
Center: 1994.8 MHz Span: 1.5MHz RBW: 3 kHz VBW: 10 kHz

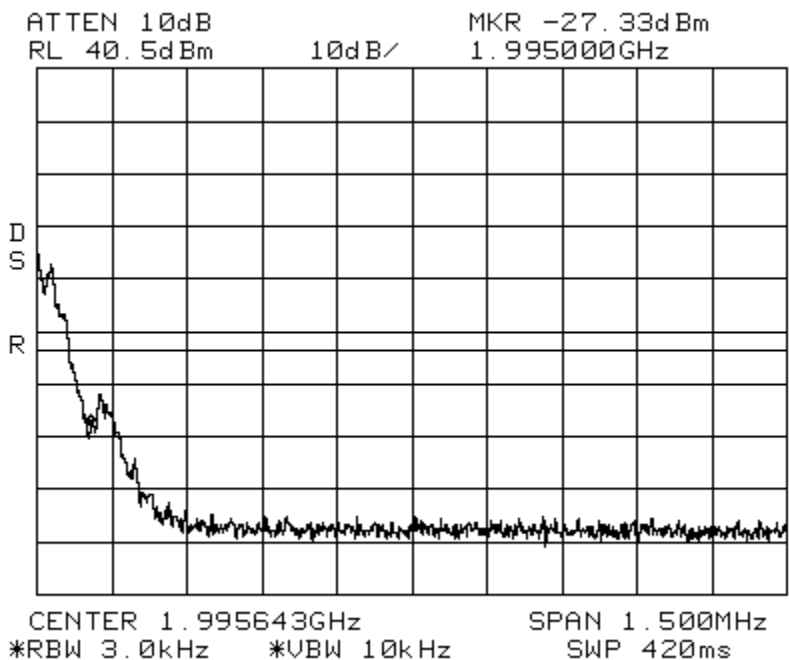

Band_Edge LTE 3 MHz Channel Bandwidth Spectrum PCS
Center: 1931.5 MHz Span: 10 MHz RBW: 30 kHz VBW: 100 kHz
ATTEN 10dB MKR -21.00dBm
RL 40.5dBm 10dB/ 1.93001GHz

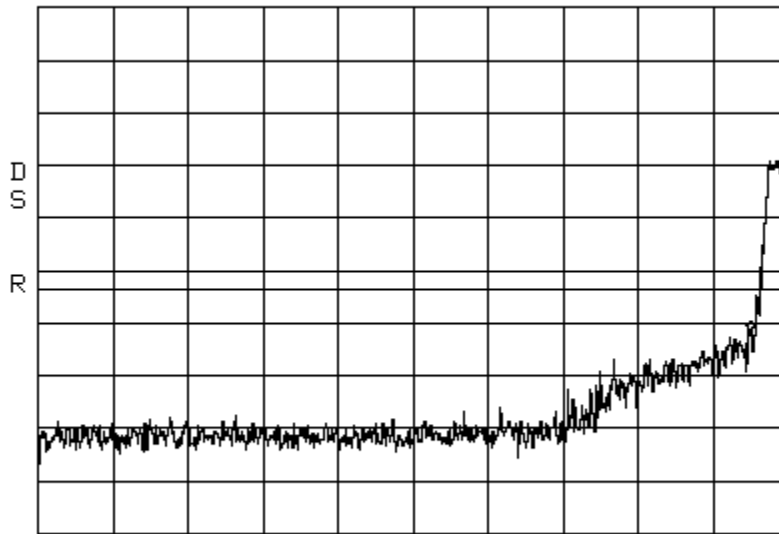

CENTER 1.92551GHz SPAN 10.00MHz
*RBW 30kHz *VBW 100kHz SWP 50ms

Band_Edge LTE 3MHz Channel Bandwidth Spectrum PCS
Center: 1993.5MHz Span: 10 MHz RBW: 30 kHz VBW: 100 kHz
ATTEN 10dB MKR -19.17dBm
RL 40.5dBm 10dB/ 1.99500GHz

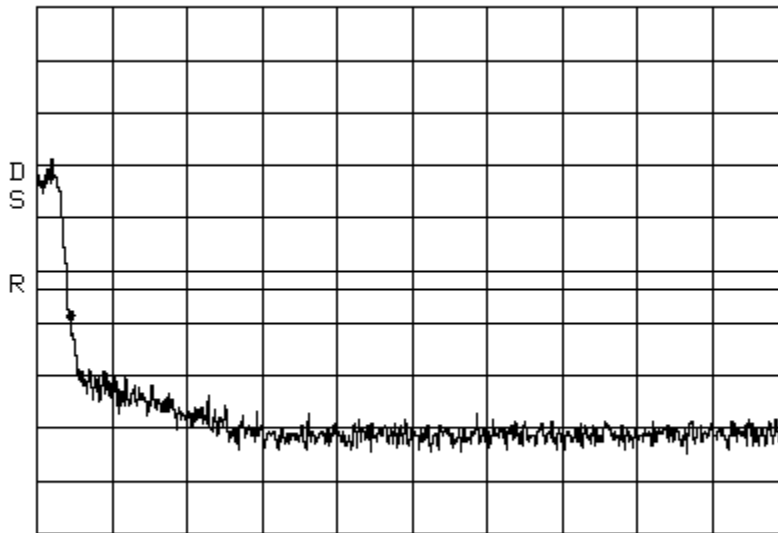

CENTER 1.99955GHz SPAN 10.00MHz
*RBW 30kHz *VBW 100kHz SWP 50ms

Band_Edge LTE 5 MHz Channel Bandwidth Spectrum PCS
Center: 1932.5MHz Span: 10 MHz RBW: 30 kHz VBW: 100 kHz
ATTEN 10dB MKR -27.17dBm
RL 40.5dBm 10dB/ 1.93000GHz

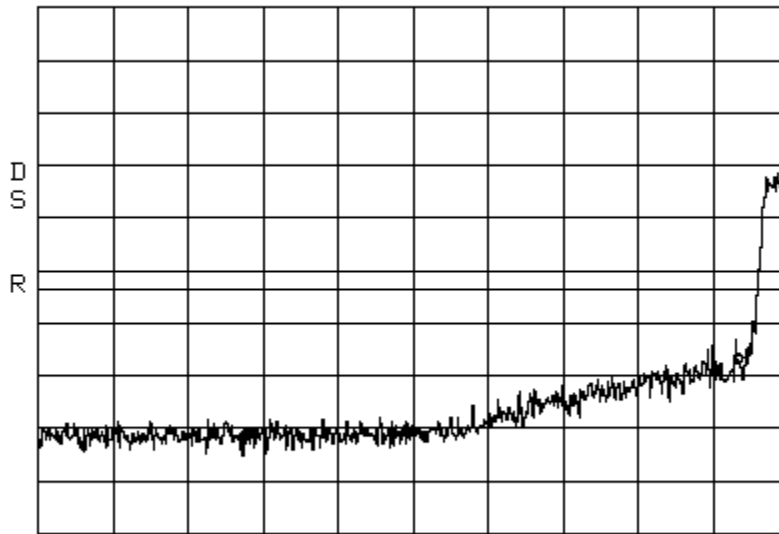

CENTER 1.92565GHz SPAN 10.00MHz
*RBW 30kHz *VBW 100kHz SWP 50ms

Band_Edge LTE 5 MHz Channel Bandwidth Spectrum PCS
Center: 1992.5MHz Span: 10 MHz RBW: 30 kHz VBW: 100 kHz

ATTEN 10dB MKR -27.67dBm
RL 40.5dBm 10dB/ 1.99500GHz

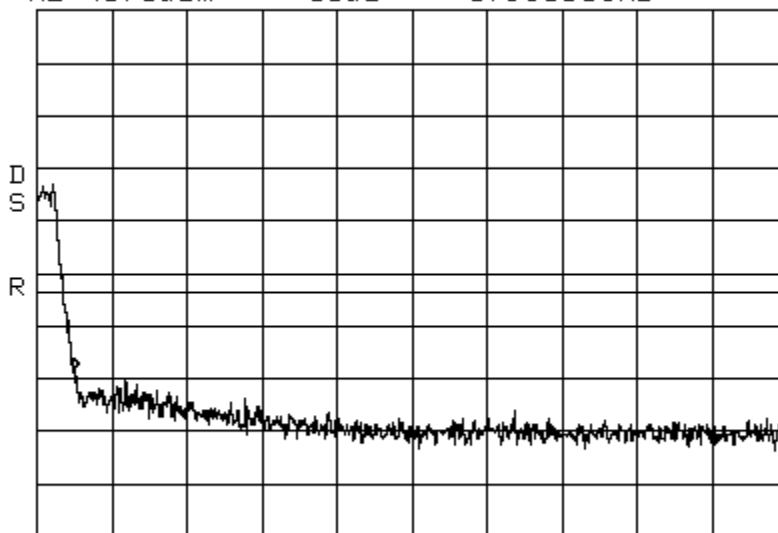

CENTER 1.99950GHz SPAN 10.00MHz
*RBW 30kHz *VBW 100kHz SWP 50ms

Band_Edge LTE 10 MHz Channel Bandwidth
Center: 1935.0MHz Span: 15 MHz RBW: 100 kHz
ATTEN 10dB MKR -26.67dBm
RL 40.5dBm 10dB/ 1.93000GHz

Spectrum PCS
VBW: 100 kHz

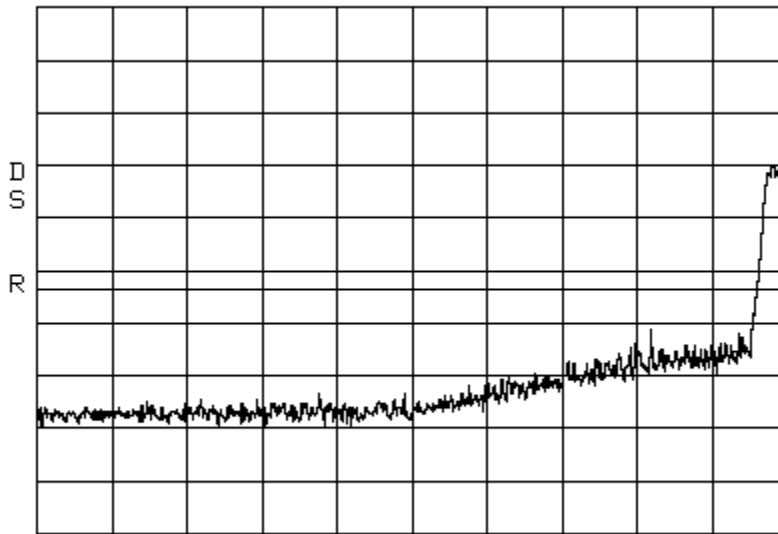

CENTER 1.92355GHz SPAN 15.00MHz
*RBW 100kHz *VBW 100kHz SWP 50ms

Band_Edge LTE 10 MHz Channel Bandwidth
Center: 1990.0MHz Span: 15 MHz RBW: 100 kHz

Spectrum PCS
VBW: 100 kHz

ATTEN 10dB MKR -29.67dBm
RL 40.5dBm 10dB/ 1.99500GHz

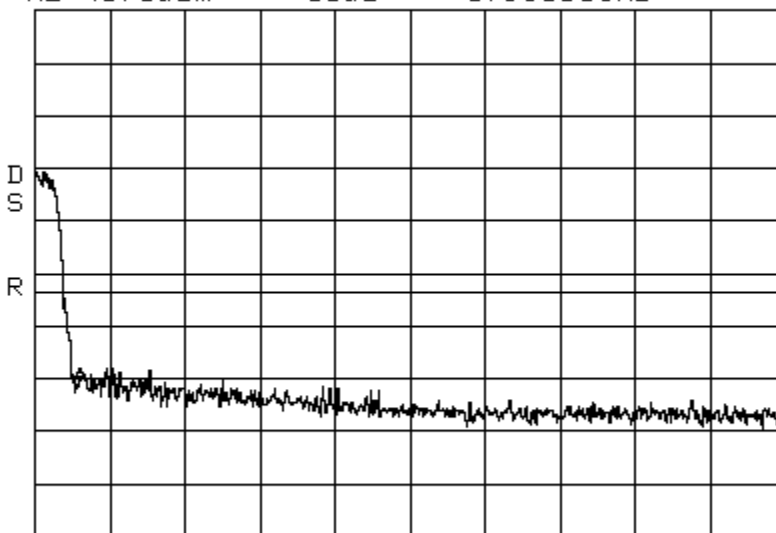

CENTER 2.00160GHz SPAN 15.00MHz
*RBW 100kHz *VBW 100kHz SWP 50ms

Band_Edge LTE 15 MHz Channel Bandwidth
Center: 1937.5MHz Span: 15 MHz RBW: 100 kHz
ATTEN 10dB MKR -26.17dBm
RL 40.5dBm 10dB/ 1.93000GHz

Spectrum PCS
VBW: 100 kHz

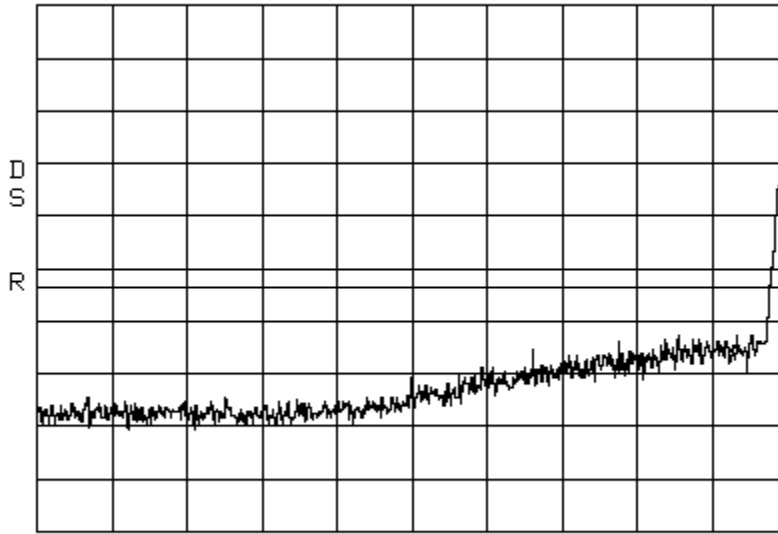

CENTER 1.92355GHz SPAN 15.00MHz
*RBW 100kHz *VBW 100kHz SWP 50ms

Band_Edge LTE 15 MHz Channel Bandwidth
Center: 1987.5MHz Span: 15 MHz RBW: 100kHz

Spectrum PCS
VBW: 100 kHz

ATTEN 10dB MKR -33.50dBm
RL 40.5dBm 10dB/ 1.99500GHz

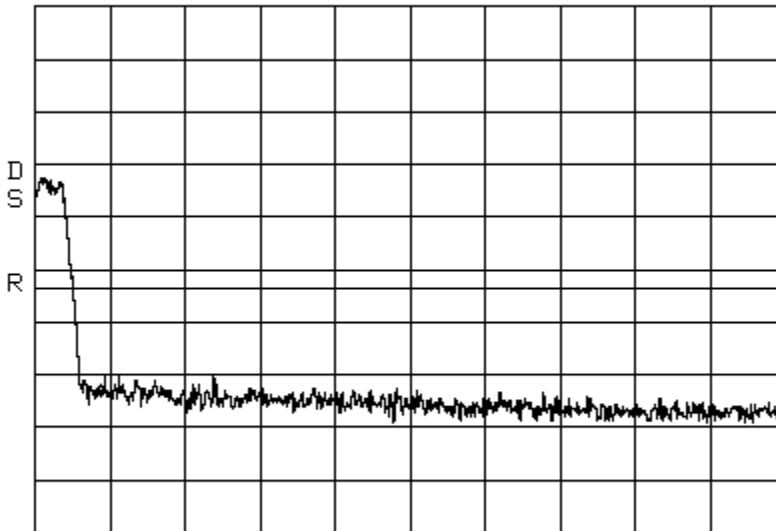

CENTER 2.00118GHz SPAN 15.00MHz
*RBW 100kHz *VBW 100kHz SWP 50ms

Band_Edge LTE 20 MHz Channel Bandwidth
Center: 1940.0MHz Span: 20 MHz RBW: 100 kHz
ATTEN 10dB MKR -27.33dBm
RL 40.5dBm 10dB/ 1.93000GHz

Spectrum PCS
VBW: 100 kHz

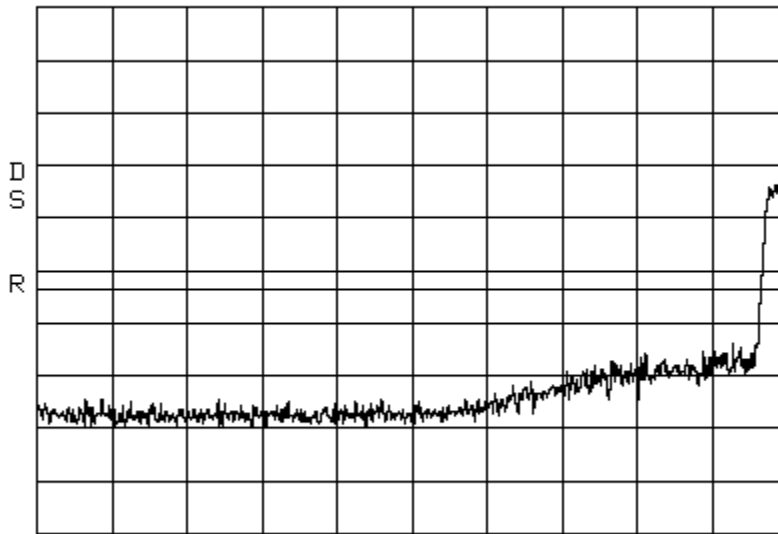

CENTER 1.92170GHz SPAN 20.00MHz
*RBW 100kHz *VBW 100kHz SWP 50ms

Band_Edge LTE 20 MHz Channel Bandwidth
Center: 1985.0MHz Span: 20 MHz RBW: 100 kHz

Spectrum PCS
VBW: 100 kHz

ATTEN 10dB MKR -34.00dBm
RL 40.5dBm 10dB/ 1.99500GHz

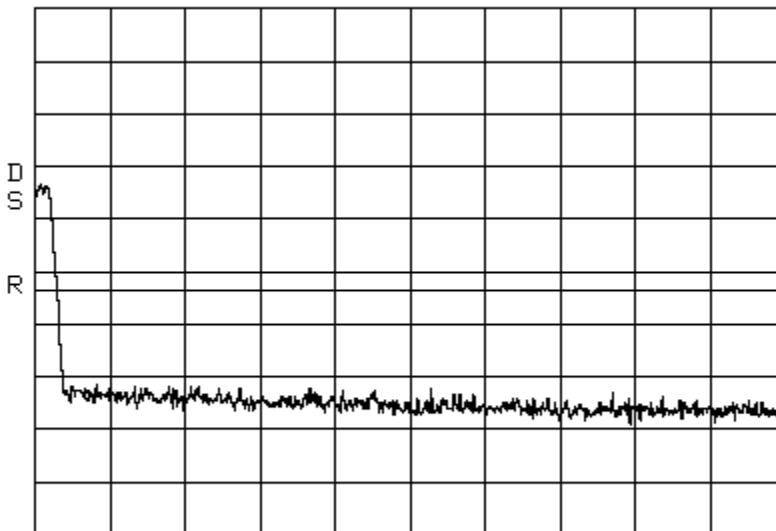

CENTER 2.00360GHz SPAN 20.00MHz
*RBW 100kHz *VBW 100kHz SWP 50ms

Band_Edge WCDMA Spectrum PCS
 Center: 1932.5 MHz Span: 10 MHz RBW: 30 kHz VBW: 100 kHz

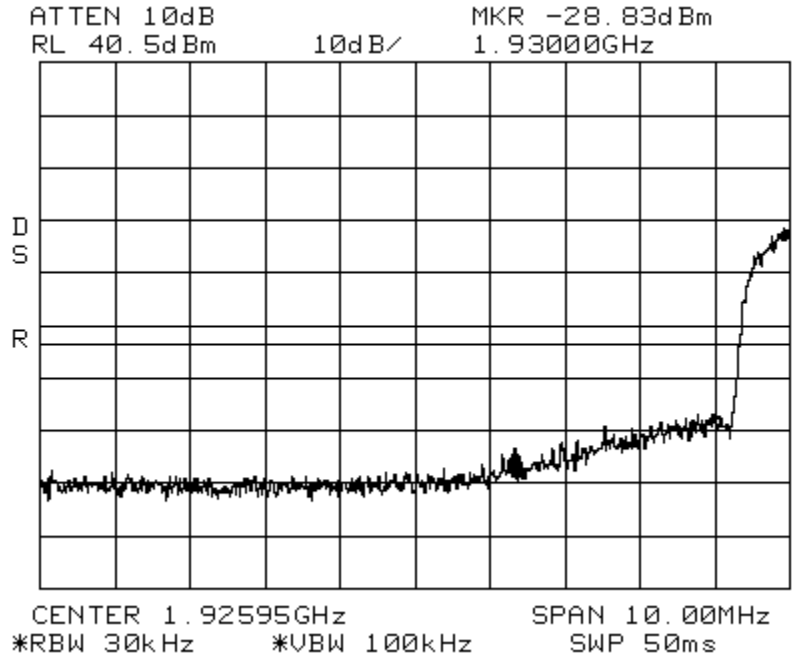

Band_Edge WCDMA Spectrum PCS
 Center: 1992.5 MHz Span: 10 MHz RBW: 30 kHz VBW: 100 kHz

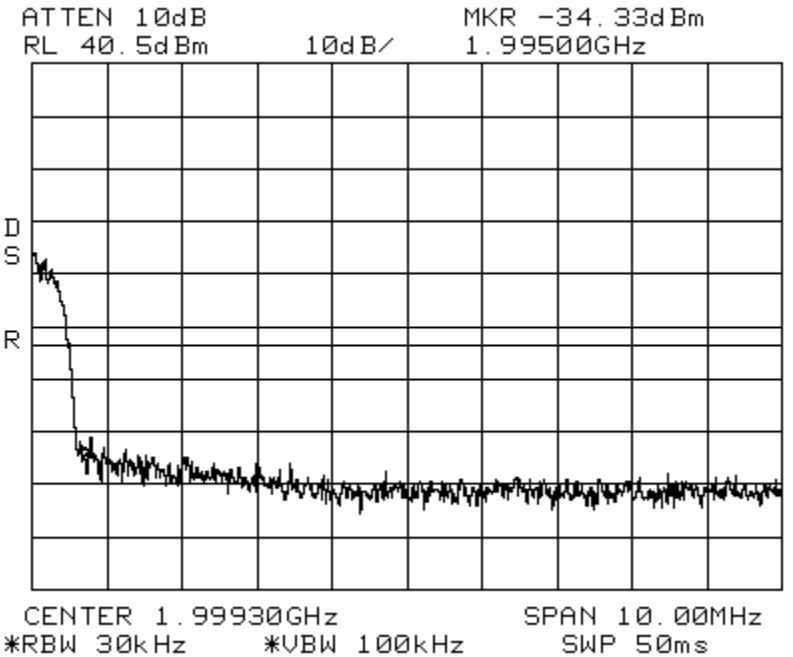

7.2 Conducted Output Power Test

[Table of Contents; Section 1.0](#)

[Back to Conducted Output Power; Section 5.1.1](#)

*Note: The EUT is a fixed repeater and not a base station.

This measurement was made as a direct conducted emission measurement. The output from the EUT antenna connector was connected to the power meter. The carrier output, below, was conducted using a single CDMA, GSM, EDGE, WCDMA, LTE 3MHz, LTE 5MHz, LTE 10MHz, LTE 15MHz, & LTE 20MHz signal generator. The power meter level was offset to compensate for attenuators and cable loss between the EUT and the power meter.

A signal was used at the low, mid and high parts of the selected band.

CELL Path1

CDMA	.3111 Watts
Carrier Frequency	Carrier Output
869.8 MHz	<u>23.53</u> dBm
881.5 MHz	<u>24.93</u> dBm
893.2 MHz	<u>23.46</u> dBm

CELL Path1

GSM	.7030 Watts
Carrier Frequency	Carrier Output
869.2 MHz	<u>26.54</u> dBm
881.5 MHz	<u>28.47</u> dBm
893.8 MHz	<u>27.96</u> dBm

CELL Path1

EDGE	.4977 Watts
Carrier Frequency	Carrier Output
869.2 MHz	<u>25.47</u> dBm
881.5 MHz	<u>26.97</u> dBm
893.8 MHz	<u>26.42</u> dBm

CELL Path1

WCDMA	.0939 Watts
Carrier Frequency	Carrier Output
871.5 MHz	<u>19.02</u> dBm
881.5 MHz	<u>19.73</u> dBm
891.5 MHz	<u>18.36</u> dBm

CELL Path1

LTE 3.0 MHz Ch. BW	.1070 Watts
Carrier Frequency	Carrier Output
870.5 MHz	<u>19.30</u> dBm
881.5 MHz	<u>20.30</u> dBm
892.5 MHz	<u>18.15</u> dBm

CELL Path1

LTE 5.0 MHz Ch. BW	.0816 Watts
Carrier Frequency	Carrier Output

871.5 MHz	<u>18.93</u> dBm
881.5 MHz	<u>19.12</u> dBm
891.5 MHz	<u>18.04</u> dBm

CELL Path1

LTE 10.0 MHz Ch. BW.0776 Watts

Carrier Frequency	Carrier Output
874.0 MHz	<u>18.90</u> dBm
881.5 MHz	<u>18.70</u> dBm
889.0 MHz	<u>18.15</u> dBm

PCS Path1

CDMA .3589 Watts

Carrier Frequency	Carrier Output
1930.8 MHz	<u>24.39</u> dBm
1962.5 MHz	<u>25.55</u> dBm
1994.2 MHz	<u>23.30</u> dBm

PCS Path1

GSM .5662 Watts

Carrier Frequency	Carrier Output
1930.2 MHz	<u>27.51</u> dBm
1962.5 MHz	<u>27.53</u> dBm
1994.8 MHz	<u>26.07</u> dBm

PCS Path1

EDGE .6067 Watts

Carrier Frequency	Carrier Output
1930.2 MHz	<u>26.62</u> dBm
1962.5 MHz	<u>27.83</u> dBm
1994.8 MHz	<u>26.10</u> dBm

PCS Path1

WCDMA .2118 Watts

Carrier Frequency	Carrier Output
1932.5 MHz	<u>20.65</u> dBm
1962.5 MHz	<u>23.26</u> dBm
1992.5 MHz	<u>20.34</u> dBm

PCS Path1

LTE 3.0 MHz Ch. BW.2506 Watts

Carrier Frequency	Carrier Output
1931.5 MHz	<u>22.58</u> dBm
1962.5 MHz	<u>23.99</u> dBm
1993.5 MHz	<u>21.15</u> dBm

PCS Path1

LTE 5.0 MHz Ch. BW.2152 Watts

Carrier Frequency	Carrier Output
1932.5 MHz	<u>22.00</u> dBm
1962.5 MHz	<u>23.33</u> dBm
1992.5 MHz	<u>20.45</u> dBm

PCS Path1

LTE 10.0 MHz Ch. BW.2393 Watts

Carrier Frequency	Carrier Output
-------------------	----------------

1935.0 MHz	<u>23.22</u> dBm
1962.5 MHz	<u>23.79</u> dBm
1990.0 MHz	<u>20.81</u> dBm

PCS Path1

LTE 15.0 MHz Ch. BW.2228 Watts

Carrier Frequency	Carrier Output
1937.5 MHz	<u>22.90</u> dBm
1962.5 MHz	<u>23.48</u> dBm
1987.5 MHz	<u>21.22</u> dBm

PCS Path1

LTE 20.0 MHz Ch. BW.2228 Watts

Carrier Frequency	Carrier Output
1940.0 MHz	<u>23.20</u> dBm
1962.5 MHz	<u>23.48</u> dBm
1985.0 MHz	<u>21.68</u> dBm

7.3 Frequency Stability Test

[Table of Contents; Section 1.0](#)
[Back to Frequency Stability; Section 5.1.1](#)

Host/DRU	IFEU	RAU			
Input Voltage	Input Voltage	Input Voltage	Carrier Frequency	Measured Frequency	Meets Requirements?
100 VAC	54VDC	54 VDC	1930.200 MHz	1930.200 MHz	Yes
170 VAC	54VDC	54 VDC	1930.200 MHz	1930.200 MHz	Yes
240 VAC	54VDC	54 VDC	1930.200 MHz	1930.200 MHz	Yes
100 VAC	54VDC	54 VDC	1962.500 MHz	1962.500 MHz	Yes
170 VAC	54VDC	54 VDC	1962.500 MHz	1962.500 MHz	Yes
240 VAC	54VDC	54 VDC	1962.500 MHz	1962.500 MHz	Yes
100 VAC	54VDC	54 VDC	1994.800 MHz	1994.800 MHz	Yes
170 VAC	54VDC	54 VDC	1994.800 MHz	1994.800 MHz	Yes
240 VAC	54VDC	54 VDC	1994.800 MHz	1994.800 MHz	Yes
Temperature			Carrier Frequency	Measured Frequency	Meets Requirements?
-25 Deg. C			1930.200 MHz	1930.200 MHz	Yes
-20 Deg. C			1930.200 MHz	1930.200 MHz	Yes
-10 Deg. C			1930.200 MHz	1930.200 MHz	Yes
0 Deg. C			1930.200 MHz	1930.200 MHz	Yes
10 Deg. C			1930.200 MHz	1930.200 MHz	Yes
20 Deg. C			1930.200 MHz	1930.200 MHz	Yes
30 Deg. C			1930.200 MHz	1930.200 MHz	Yes
40 Deg. C			1930.200 MHz	1930.200 MHz	Yes
45 Deg. C			1930.200 MHz	1930.200 MHz	Yes
50 Deg. C			1930.200 MHz	1930.200 MHz	Yes
-25 Deg. C			1962.500 MHz	1962.500 MHz	Yes
-20 Deg. C			1962.500 MHz	1962.500 MHz	Yes
-10 Deg. C			1962.500 MHz	1962.500 MHz	Yes
0 Deg. C			1962.500 MHz	1962.500 MHz	Yes
10 Deg. C			1962.500 MHz	1962.500 MHz	Yes
20 Deg. C			1962.500 MHz	1962.500 MHz	Yes
30 Deg. C			1962.500 MHz	1962.500 MHz	Yes
40 Deg. C			1962.500 MHz	1962.500 MHz	Yes
45 Deg. C			1962.500 MHz	1962.500 MHz	Yes
50 Deg. C			1962.500 MHz	1962.500 MHz	Yes
-25 Deg. C			1994.800 MHz	1994.800 MHz	Yes
-20 Deg. C			1994.800 MHz	1994.800 MHz	Yes
-10 Deg. C			1994.800 MHz	1994.800 MHz	Yes
0 Deg. C			1994.800 MHz	1994.800 MHz	Yes
10 Deg. C			1994.800 MHz	1994.800 MHz	Yes
20 Deg. C			1994.800 MHz	1994.800 MHz	Yes
30 Deg. C			1994.800 MHz	1994.800 MHz	Yes
40 Deg. C			1994.800 MHz	1994.800 MHz	Yes
45 Deg. C			1994.800 MHz	1994.800 MHz	Yes
50 Deg. C			1994.800 MHz	1994.800 MHz	Yes
Host/DRU	IFEU	RAU			
Input Voltage	Input Voltage	Input Voltage	Carrier Frequency	Measured Frequency	Meets Requirements?

100 VAC	54VDC	54 VDC	869.200 MHz	869.200 MHz	Yes
170 VAC	54VDC	54 VDC	869.200 MHz	869.200 MHz	Yes
240 VAC	54VDC	54 VDC	869.200 MHz	869.200 MHz	Yes
100 VAC	54VDC	54 VDC	881.500 MHz	881.500 MHz	Yes
170 VAC	54VDC	54 VDC	881.500 MHz	881.500 MHz	Yes
240 VAC	54VDC	54 VDC	881.500 MHz	881.500 MHz	Yes
100 VAC	54VDC	54 VDC	893.800 MHz	893.800 MHz	Yes
170 VAC	54VDC	54 VDC	893.800 MHz	893.800 MHz	Yes
240 VAC	54VDC	54 VDC	893.800 MHz	893.800 MHz	Yes
Temperature			Carrier Frequency	Measured Frequency	Meets Requirements?
-25 Deg. C			869.200 MHz	869.200 MHz	Yes
-20 Deg. C			869.200 MHz	869.200 MHz	Yes
-10 Deg. C			869.200 MHz	869.200 MHz	Yes
0 Deg. C			869.200 MHz	869.200 MHz	Yes
10 Deg. C			869.200 MHz	869.200 MHz	Yes
20 Deg. C			869.200 MHz	869.200 MHz	Yes
30 Deg. C			869.200 MHz	869.200 MHz	Yes
40 Deg. C			869.200 MHz	869.200 MHz	Yes
45 Deg. C			869.200 MHz	869.200 MHz	Yes
50 Deg. C			869.200 MHz	869.200 MHz	Yes
-25 Deg. C			881.500 MHz	881.500 MHz	Yes
-20 Deg. C			881.500 MHz	881.500 MHz	Yes
-10 Deg. C			881.500 MHz	881.500 MHz	Yes
0 Deg. C			881.500 MHz	881.500 MHz	Yes
10 Deg. C			881.500 MHz	881.500 MHz	Yes
20 Deg. C			881.500 MHz	881.500 MHz	Yes
30 Deg. C			881.500 MHz	881.500 MHz	Yes
40 Deg. C			881.500 MHz	881.500 MHz	Yes
45 Deg. C			881.500 MHz	881.500 MHz	Yes
50 Deg. C			881.500 MHz	881.500 MHz	Yes
-25 Deg. C			893.800 MHz	893.800 MHz	Yes
-20 Deg. C			893.800 MHz	893.800 MHz	Yes
-10 Deg. C			893.800 MHz	893.800 MHz	Yes
0 Deg. C			893.800 MHz	893.800 MHz	Yes
10 Deg. C			893.800 MHz	893.800 MHz	Yes
20 Deg. C			893.800 MHz	893.800 MHz	Yes
30 Deg. C			893.800 MHz	893.800 MHz	Yes
40 Deg. C			893.800 MHz	893.800 MHz	Yes
45 Deg. C			893.800 MHz	893.800 MHz	Yes
50 Deg. C			893.800 MHz	893.800 MHz	Yes

7.4 Intermodulation Test

[Table of Contents; Section 1.0](#)

[Back to Emission Limits; Section 5.1.3](#)

The inter-modulation products test was performed for the EUT. Three tests were performed with the modulation type. Test 1 was with 2 signals input to the EUT at lower end channels. Test 2 was with 2 signals input to the EUT at upper end channels. Test 3 was with 2 signals input to the EUT at upper and lower end channels. The modulation types tested were CDMA, GSM, EDGE, WCDMA, LTE 3MHz, LTE 5MHz, LTE 10MHz, LTE 15MHz, & LTE 20MHz. An investigation was made from 30 MHz to the 10th Harmonic of the highest fundamental frequency (~20 GHz). The following plots show the results.

Results:
(See Plots)

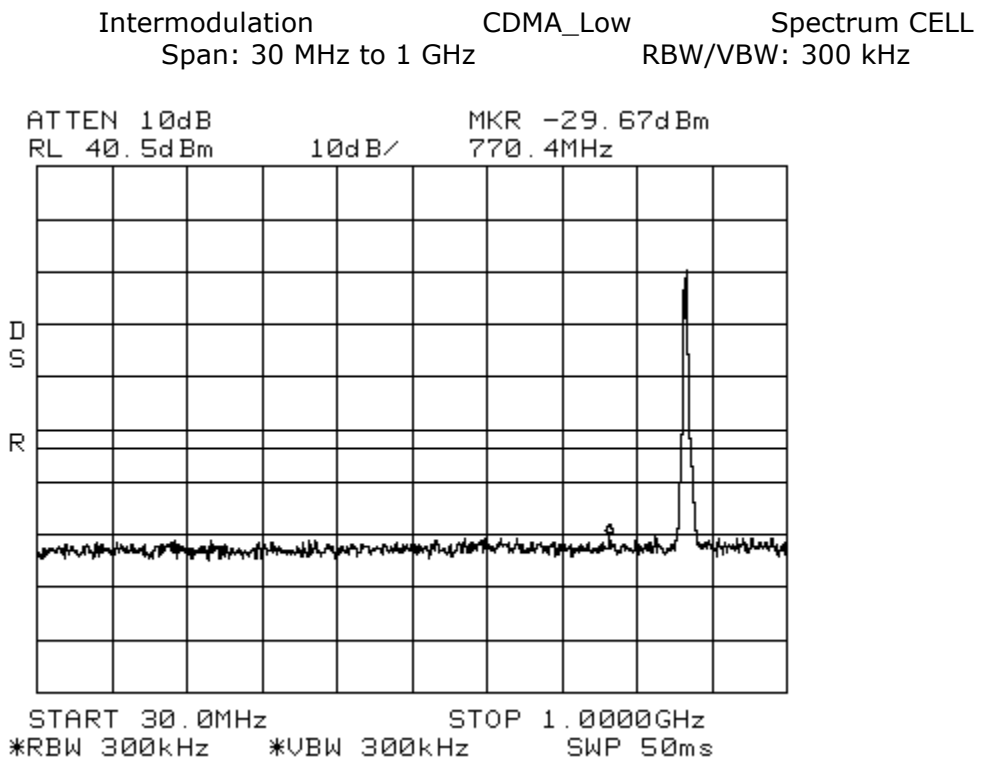
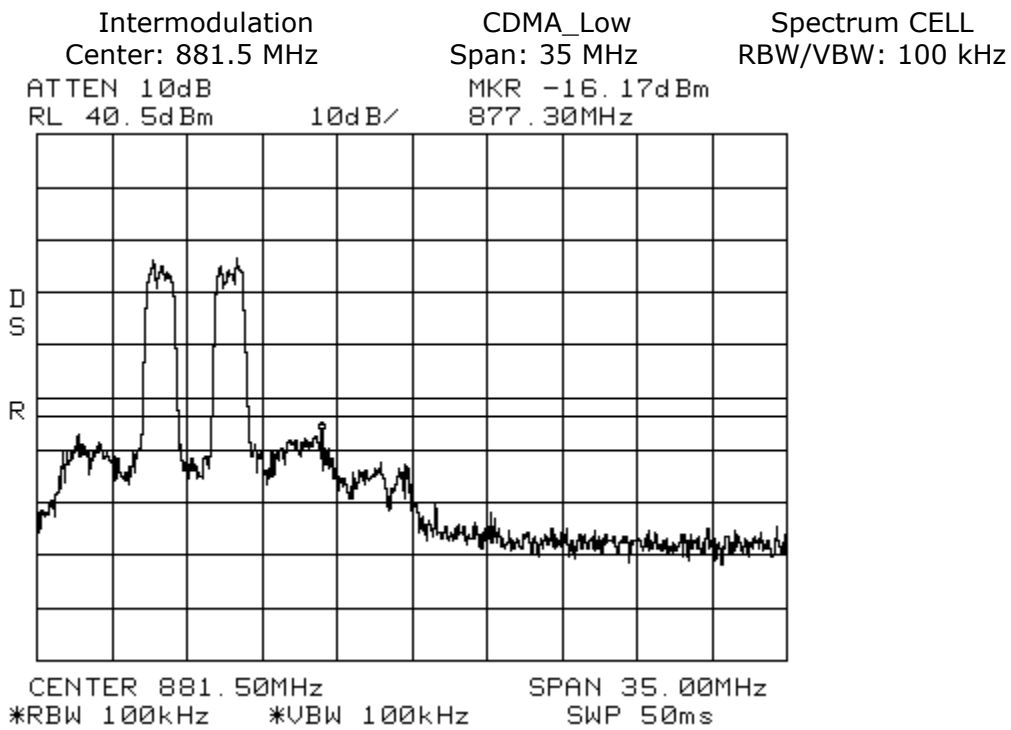

Intermodulation CDMA_Low Spectrum CELL
Span: 1 GHz to 10 GHz RBW/VBW: 1 MHz

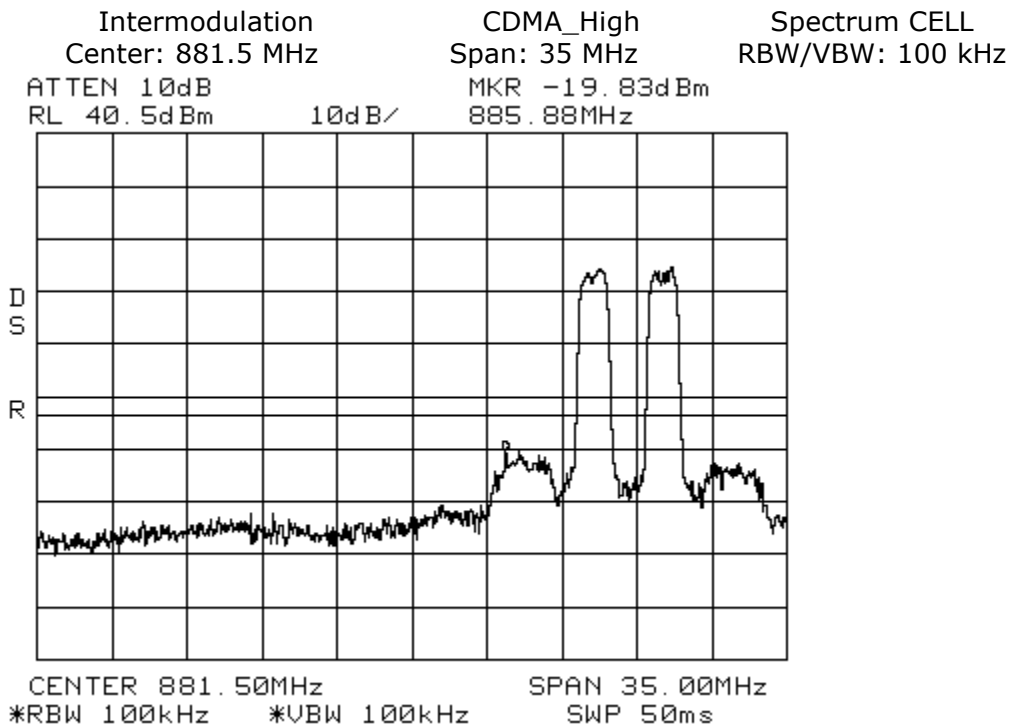
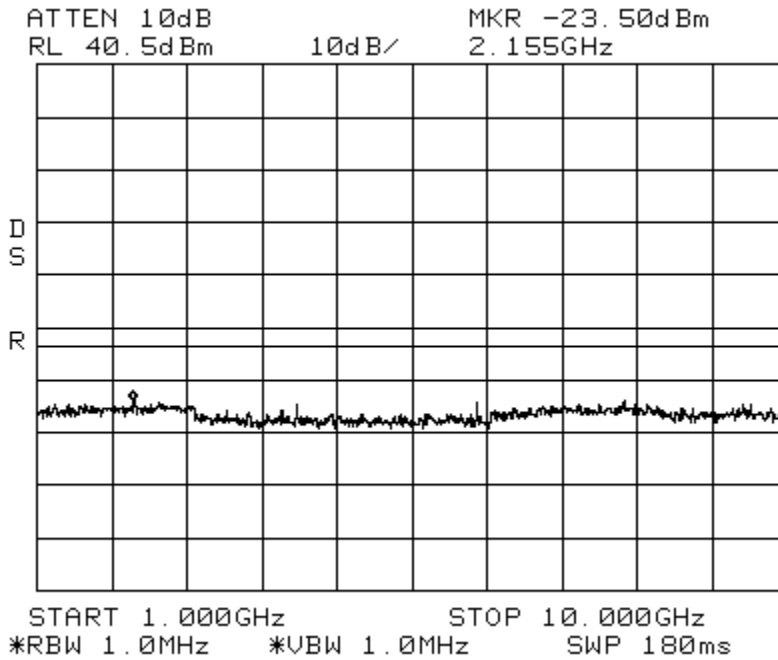

Intermodulation CDMA_High Spectrum CELL
Span: 30 MHz to 1 GHz RBW/VBW: 300 kHz

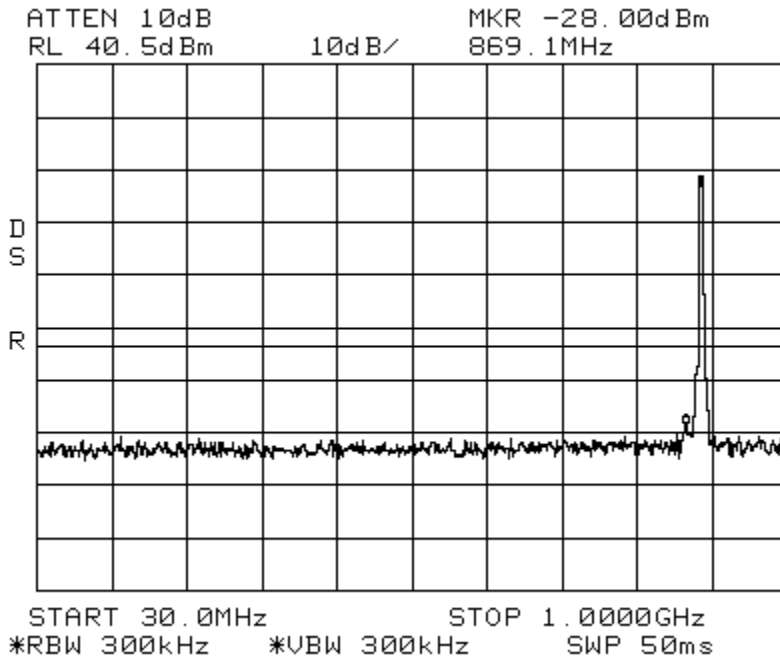

Intermodulation CDMA_High Spectrum CELL
Span: 1 GHz to 10 GHz RBW/VBW: 1 MHz

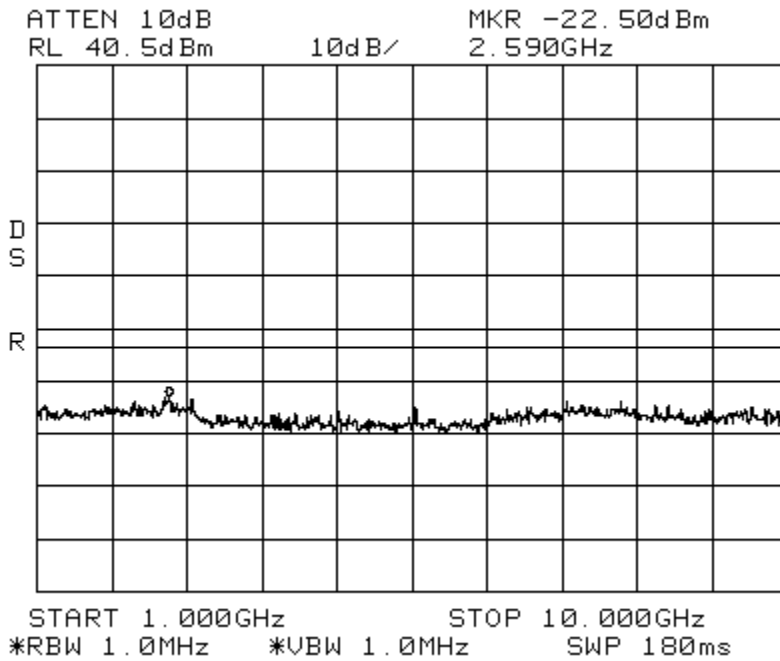

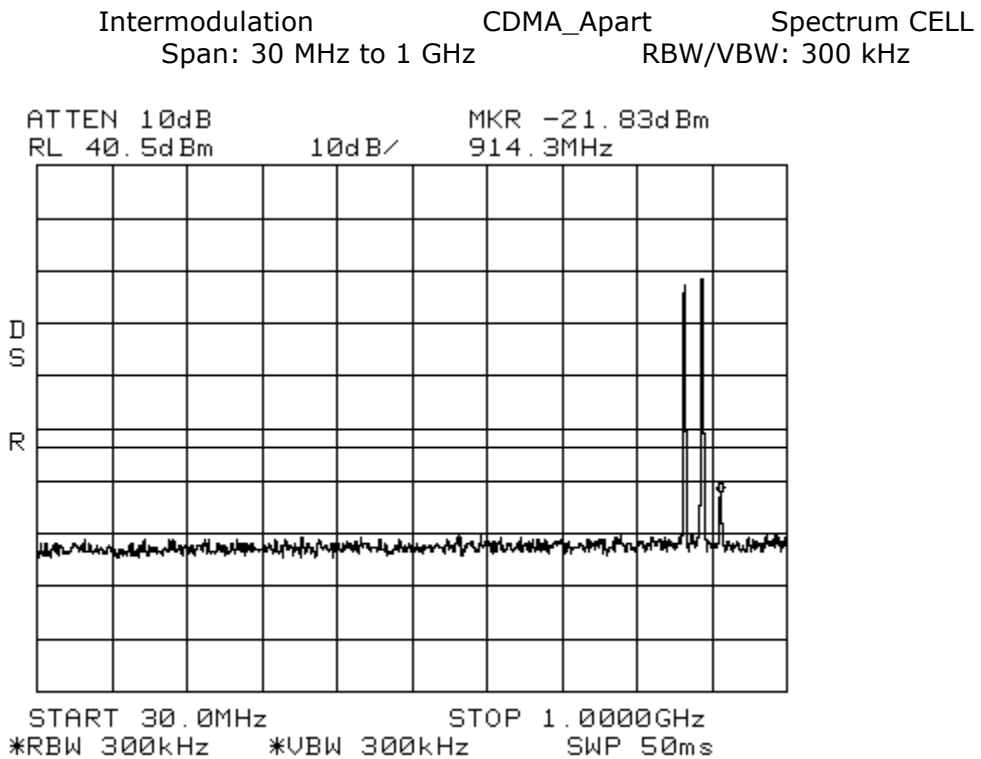
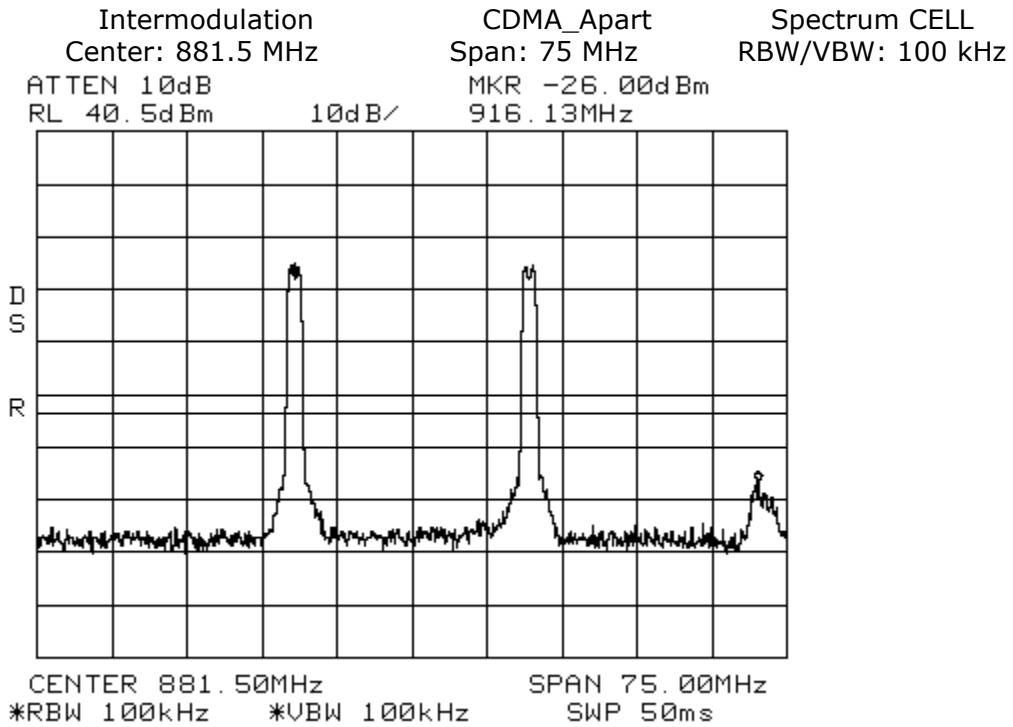

Intermodulation CDMA_Apart Spectrum CELL
Span: 1 GHz to 10 GHz RBW/VBW: 1 MHz

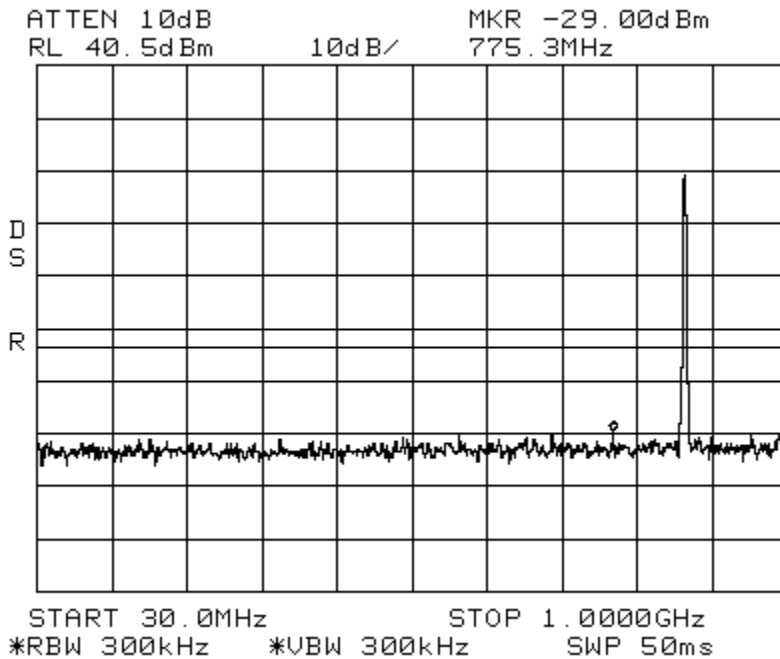

Intermodulation EDGE_Low Spectrum CELL
 Span: 1 GHz to 10 GHz RBW/VBW: 1 MHz

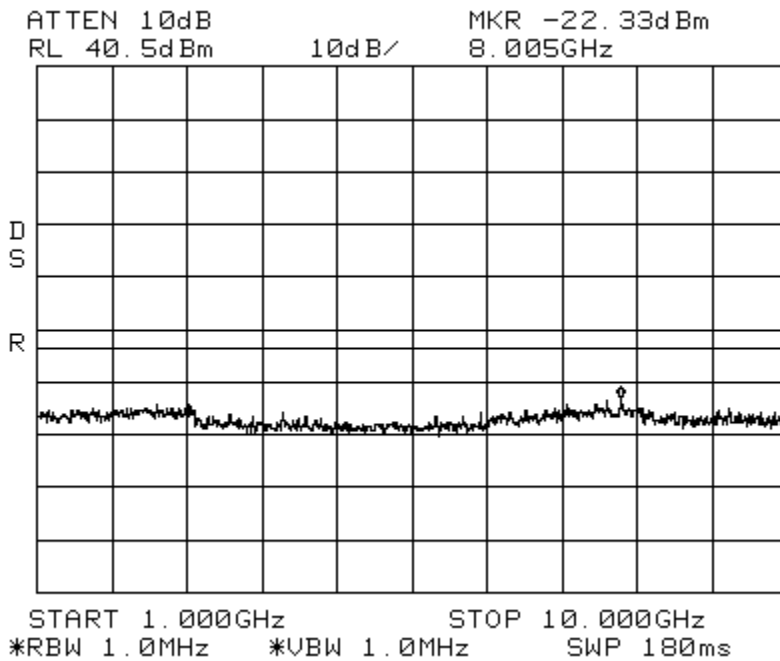

Intermodulation EDGE_High Spectrum CELL
 Center: 881.5 MHz Span: 35 MHz RBW/VBW: 100 kHz

Span: 1 GHz to 10 GHz

RBW/VBW: 1 MHz

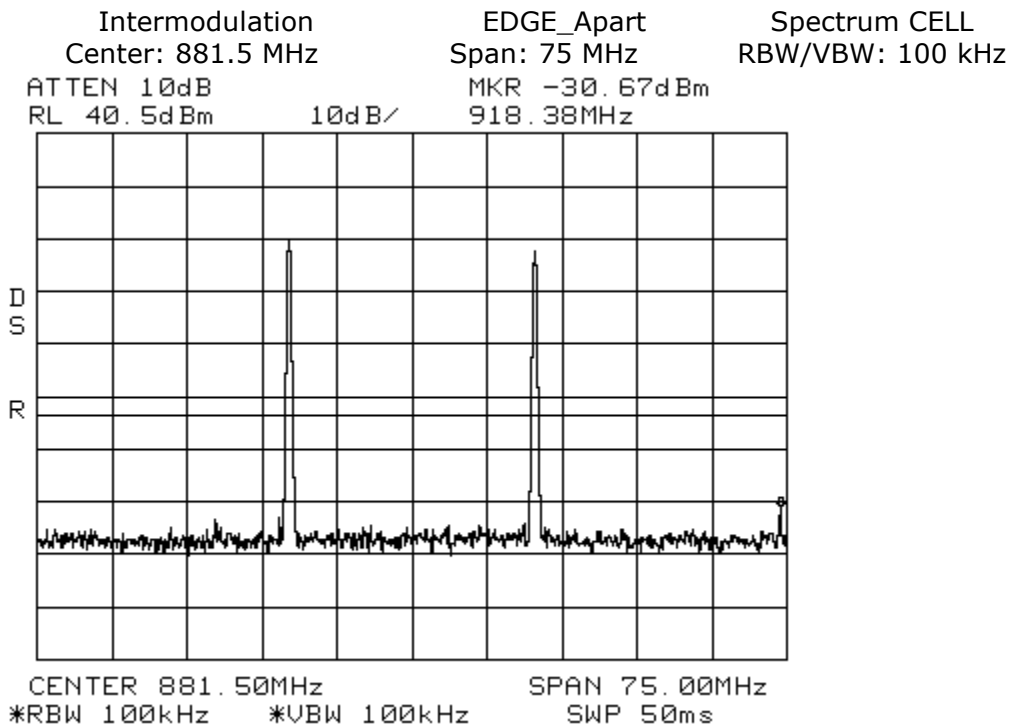
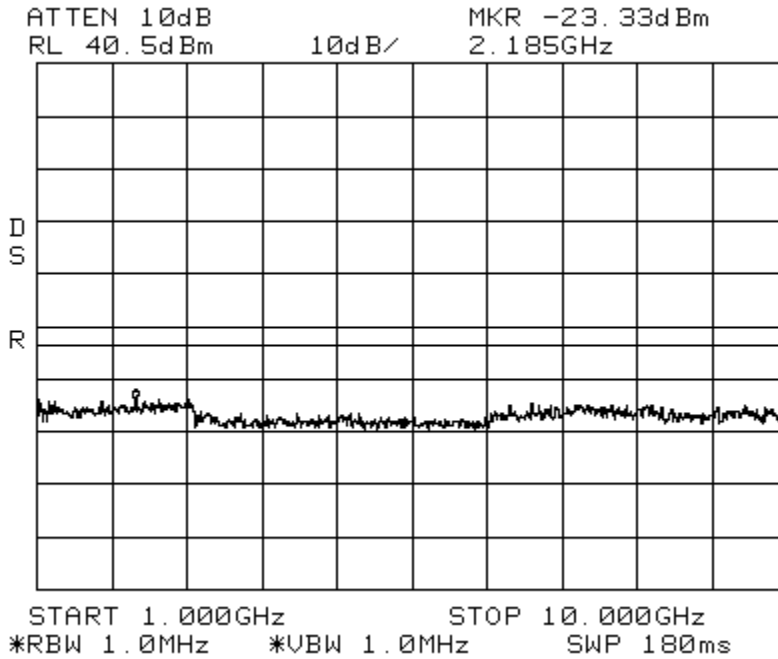

Intermodulation EDGE_Apart Spectrum CELL
Span: 30 MHz to 1 GHz RBW/VBW: 300 kHz

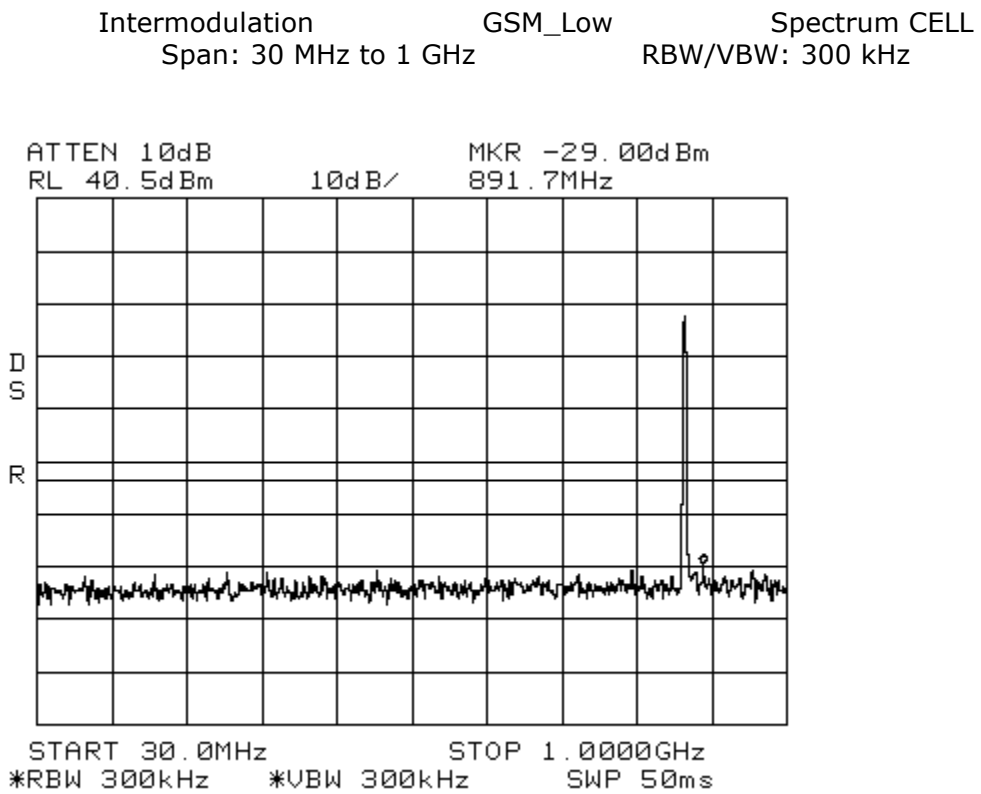
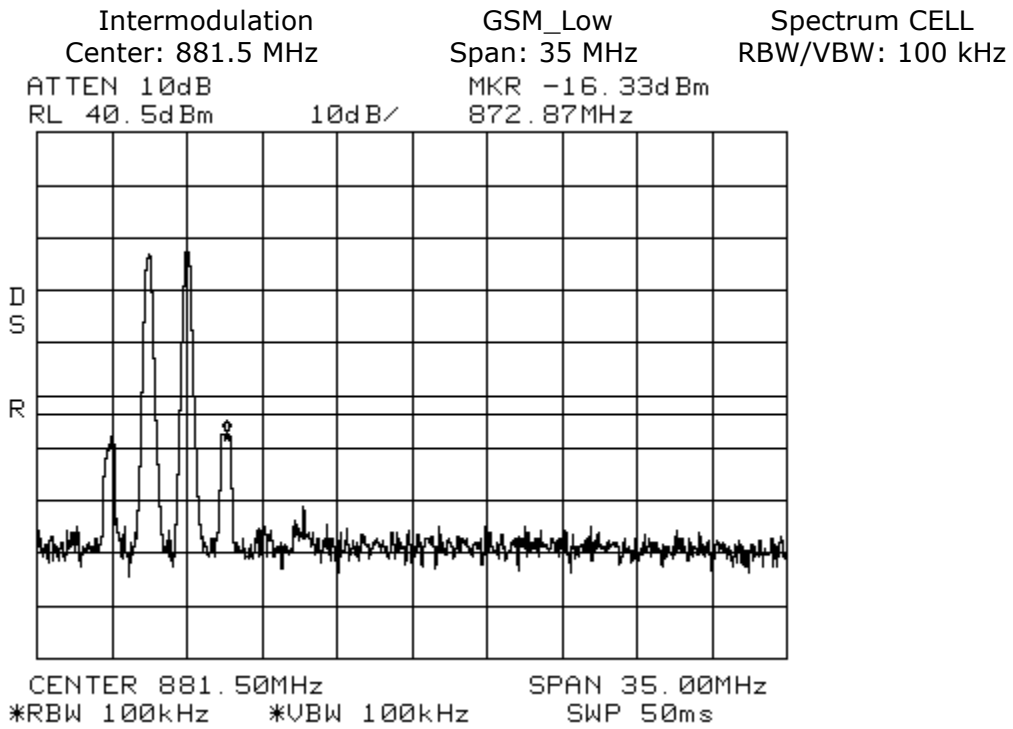

Intermodulation GSM_Low Spectrum CELL
Span: 1 GHz to 10 GHz RBW/VBW: 1 MHz

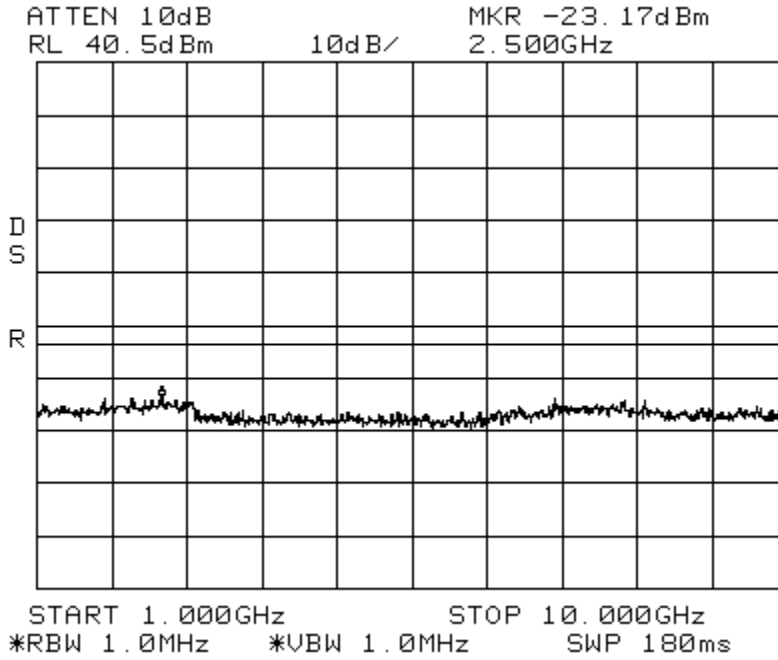

Intermodulation GSM_High Spectrum CELL
Center: 881.5 MHz Span: 35 MHz RBW/VBW: 100 kHz

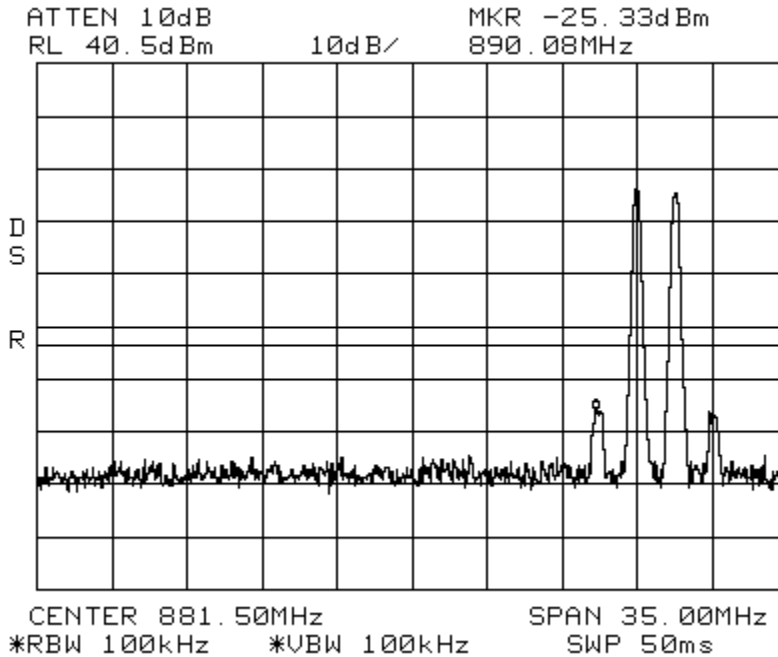

Intermodulation GSM_High Spectrum CELL
Span: 30 MHz to 1 GHz RBW/VBW: 300 kHz

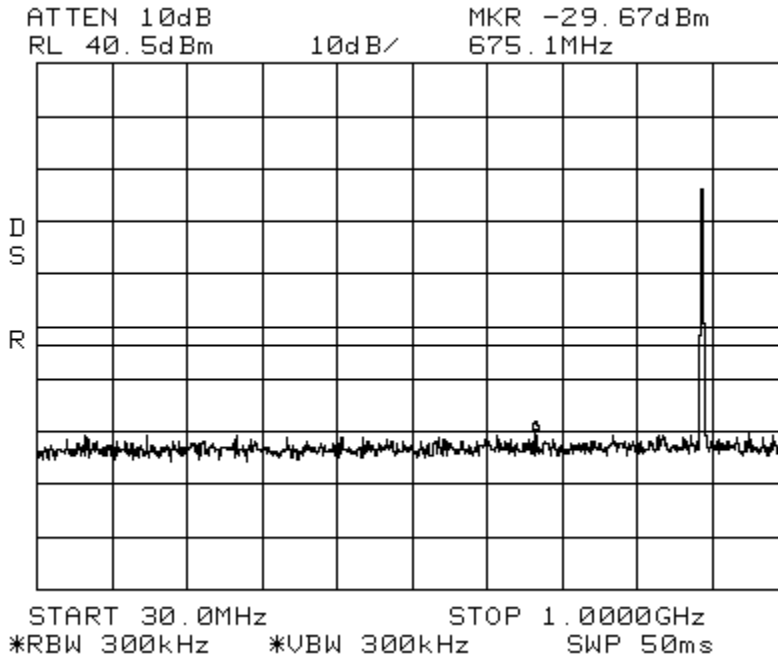

Intermodulation GSM_High Spectrum CELL
Span: 1 GHz to 10 GHz RBW/VBW: 1 MHz

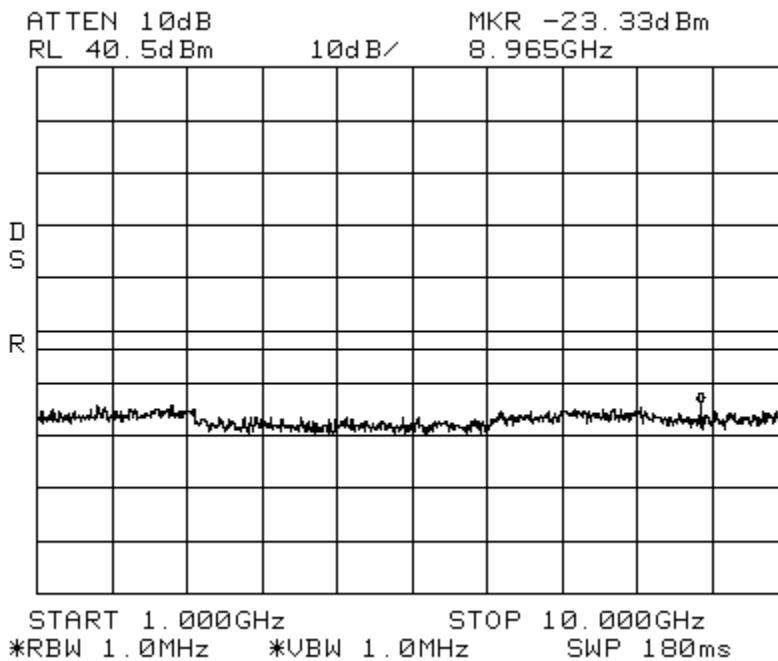

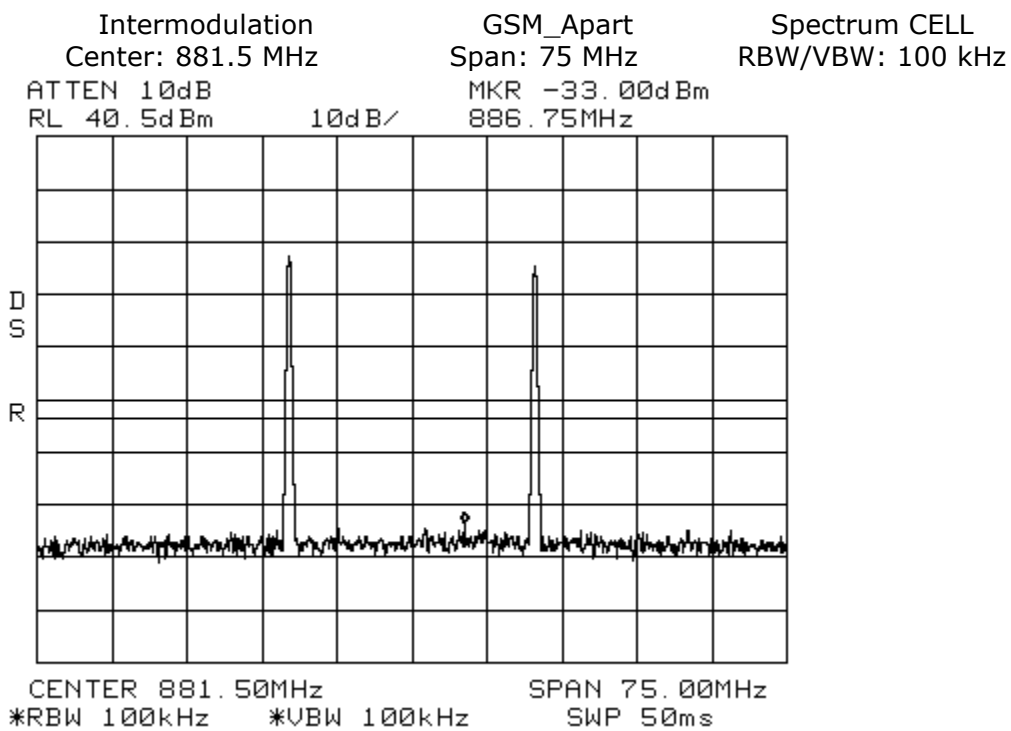

Intermodulation GSM_Apart Spectrum CELL
Span: 30 MHz to 1 GHz RBW/VBW: 300 kHz

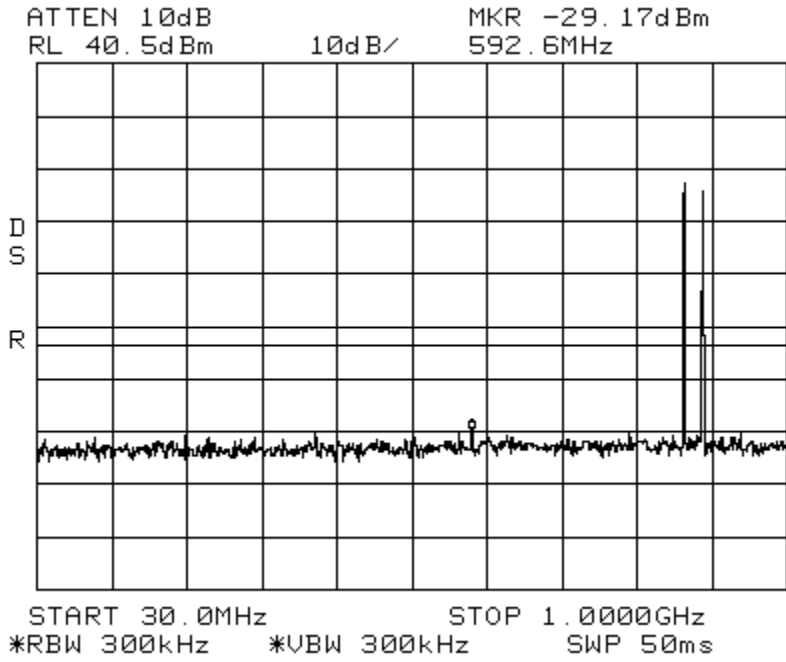

Intermodulation GSM_Apart Spectrum CELL
Span: 1 GHz to 10 GHz RBW/VBW: 1 MHz

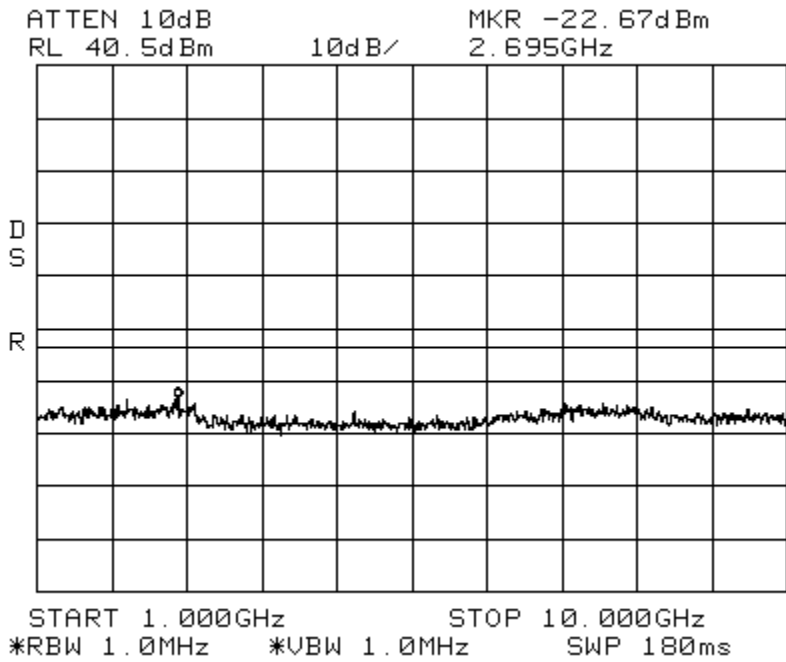

Intermodulation LTE 3MHz Channel Bandwidth _LowSpectrum CELL
Center: 881.5 MHz Span: 35 MHz RBW/VBW: 100 kHz

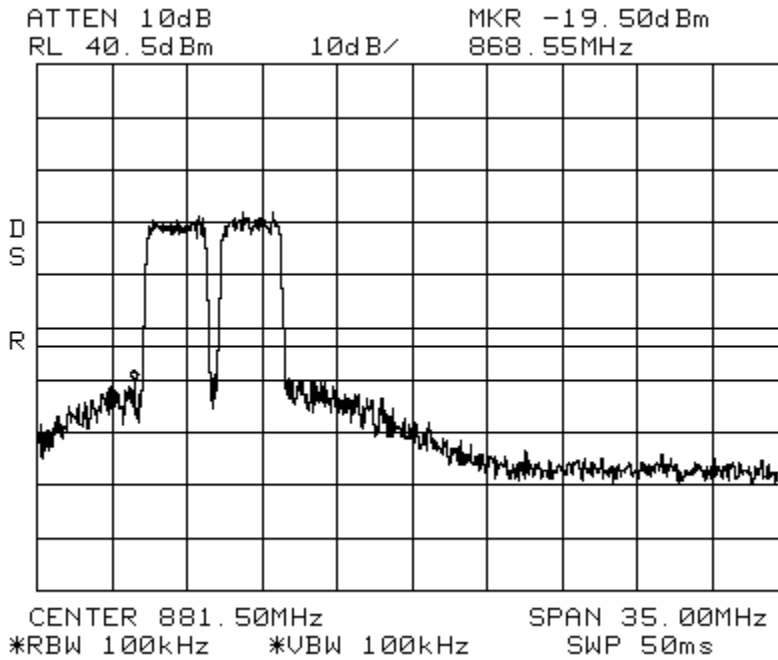

Intermodulation LTE 3MHz Channel Bandwidth _LowSpectrum CELL
Span: 30 MHz to 1 GHz RBW/VBW: 300 kHz

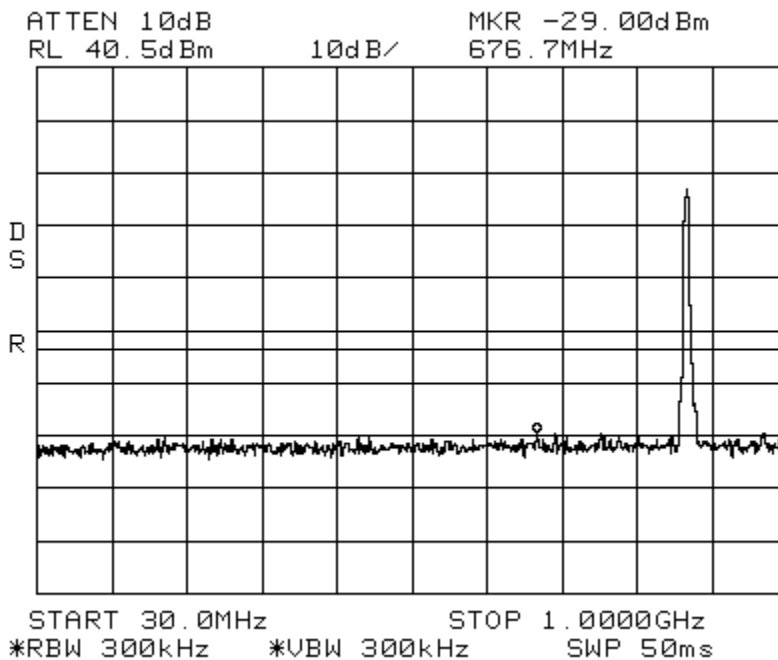

Intermodulation LTE 3 MHz Channel Bandwidth _Low Spectrum CELL
Span: 1 GHz to 10 GHz RBW/VBW: 1 MHz

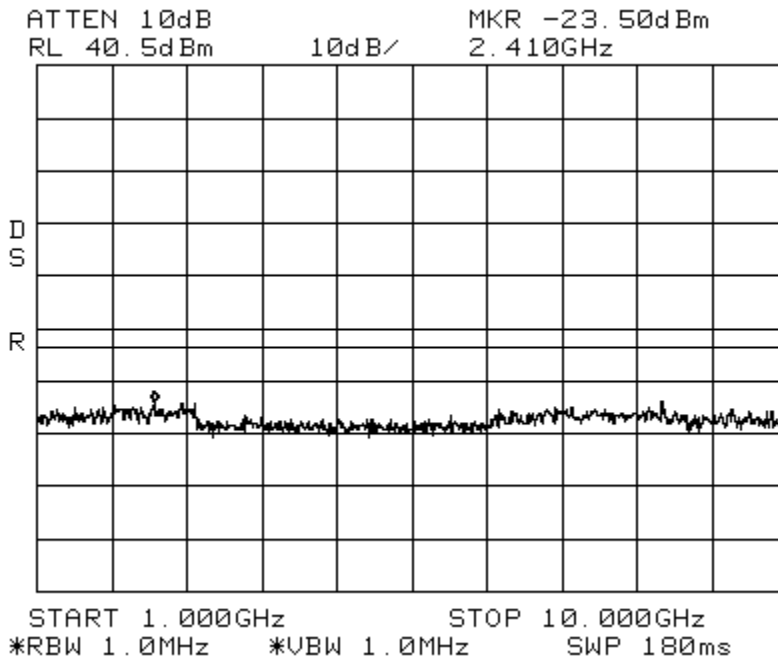

Intermodulation LTE 3 MHz Channel Bandwidth _High Spectrum CELL
Center: 881.5 MHz Span: 35 MHz RBW/VBW: 100 kHz

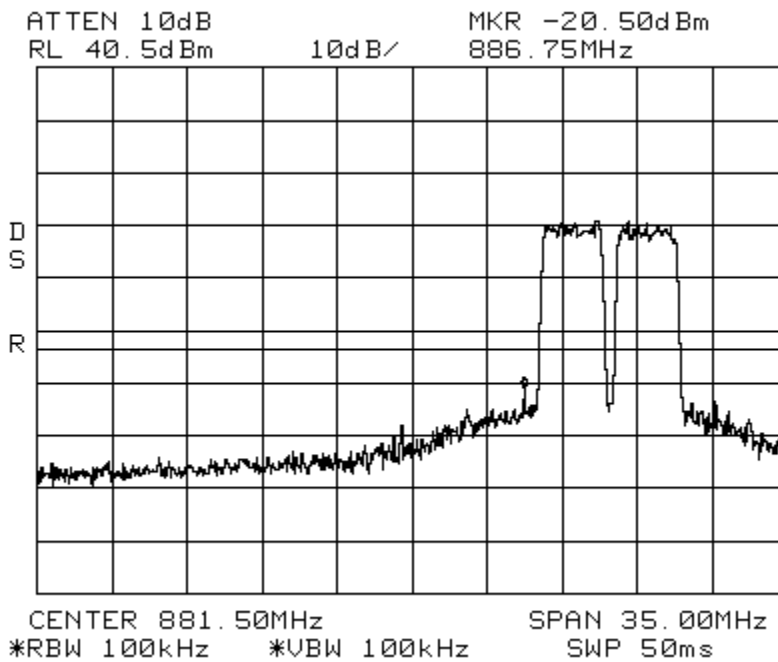

Intermodulation LTE 3 MHz Channel Bandwidth _High Spectrum CELL
Span: 30 MHz to 1 GHz RBW/VBW: 300 kHz

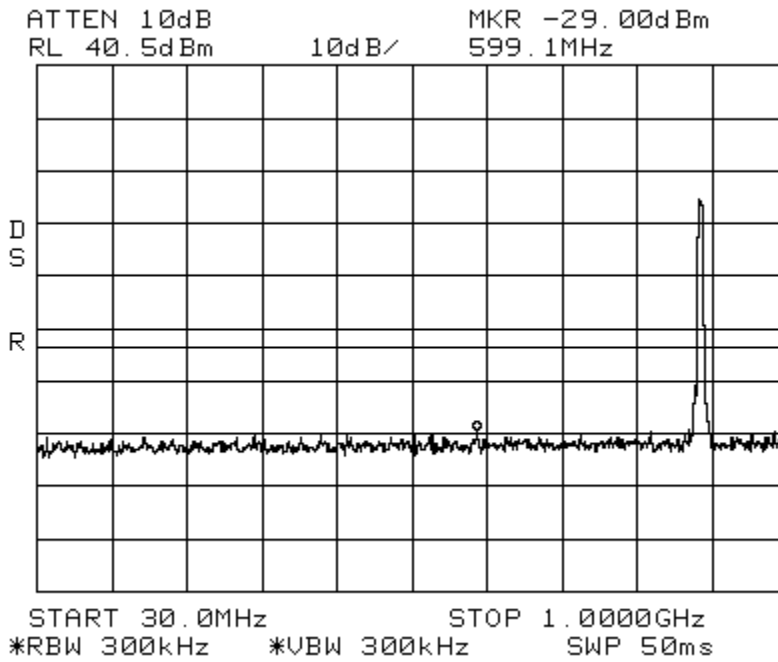

Intermodulation LTE 3 MHz Channel Bandwidth _High Spectrum CELL
Span: 1 GHz to 10 GHz RBW/VBW: 1 MHz

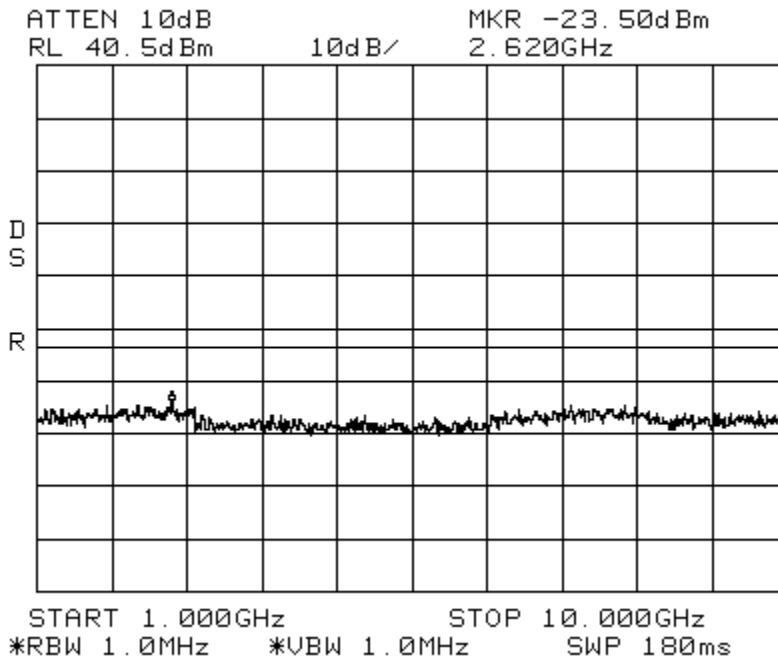

Intermodulation LTE 3 MHz Channel Bandwidth _Apart Spectrum CELL
Center: 881.5 MHz Span: 70 MHz RBW/VBW: 100 kHz

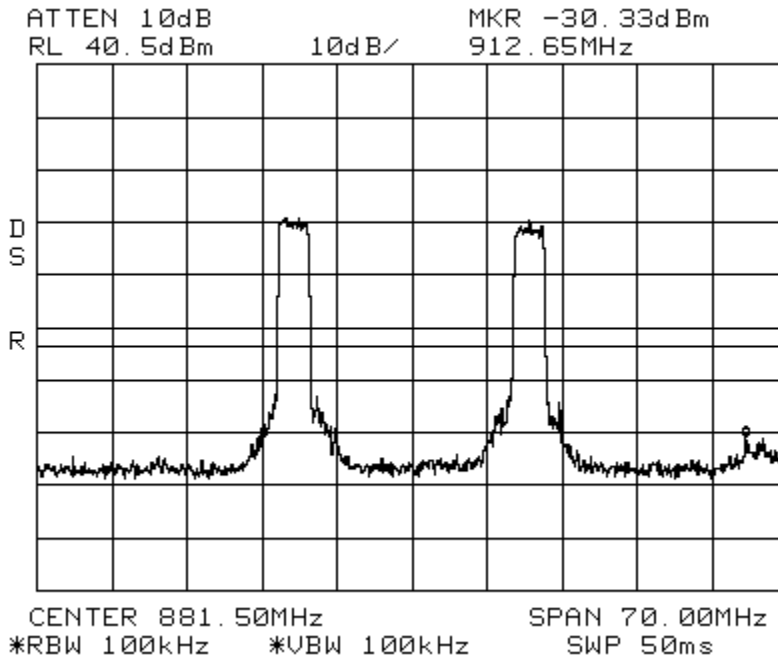

Intermodulation LTE 3 MHz Channel Bandwidth _Apart Spectrum CELL
Span: 30 MHz to 1 GHz RBW/VBW: 300 kHz

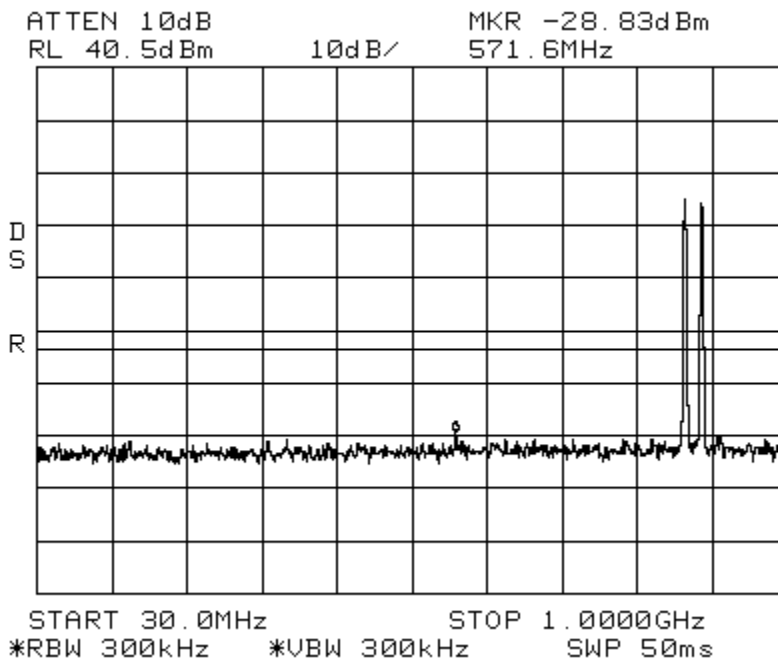

Intermodulation LTE 3 MHz Channel Bandwidth_Apart Spectrum CELL
Span: 1 GHz to 10 GHz RBW/VBW: 1 MHz

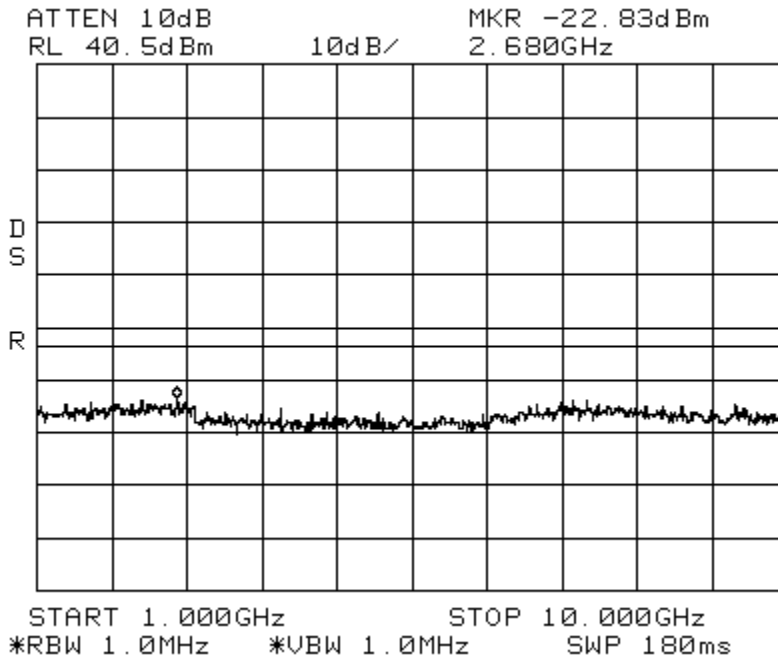

Intermodulation LTE 5 MHz Channel Bandwidth_Low Spectrum CELL
Center: 881.5 MHz Span: 35 MHz RBW/VBW: 100 kHz

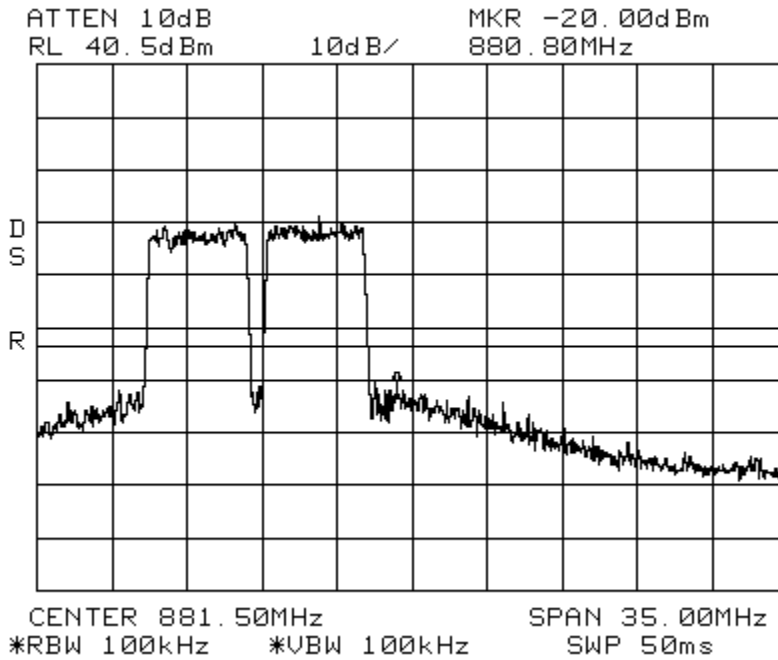

Intermodulation LTE 5 MHz Channel Bandwidth _Low Spectrum CELL
Span: 30 MHz to 1 GHz RBW/VBW: 300 kHz

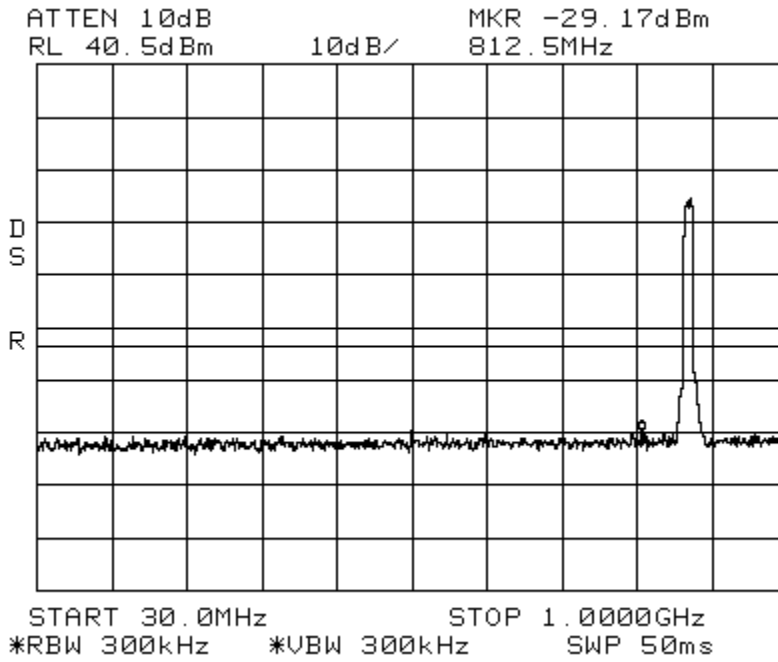

Intermodulation LTE 5 MHz Channel Bandwidth _Low Spectrum CELL
Span: 1 GHz to 10 GHz RBW/VBW: 1 MHz

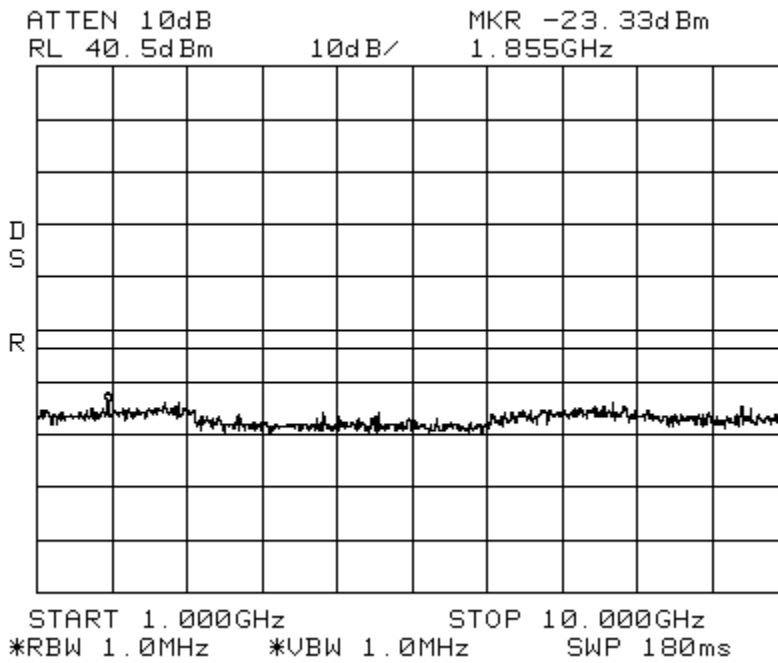

Intermodulation LTE 5 MHz Channel Bandwidth_High Spectrum CELL
Center: 881.5 MHz Span: 35 MHz RBW/VBW: 100 kHz
ATTEN 10dB MKR -25.17dBm
RL 40.5dBm 10dB/ 882.43MHz

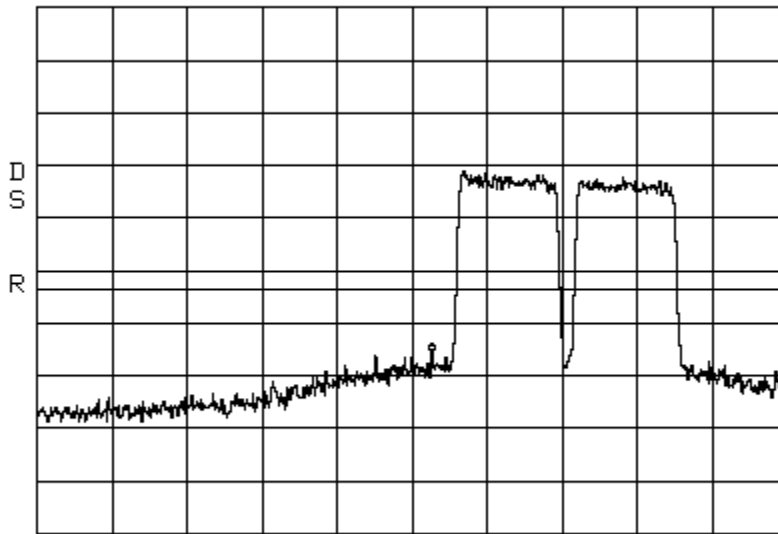

CENTER 881.50MHz SPAN 35.00MHz
*RBW 100kHz *VBW 100kHz SWP 50ms

Intermodulation LTE 5 MHz Channel Bandwidth_High Spectrum CELL
Span: 30 MHz to 1 GHz RBW/VBW: 300 kHz

ATTEN 10dB MKR -29.17dBm
RL 40.5dBm 10dB/ 573.2MHz

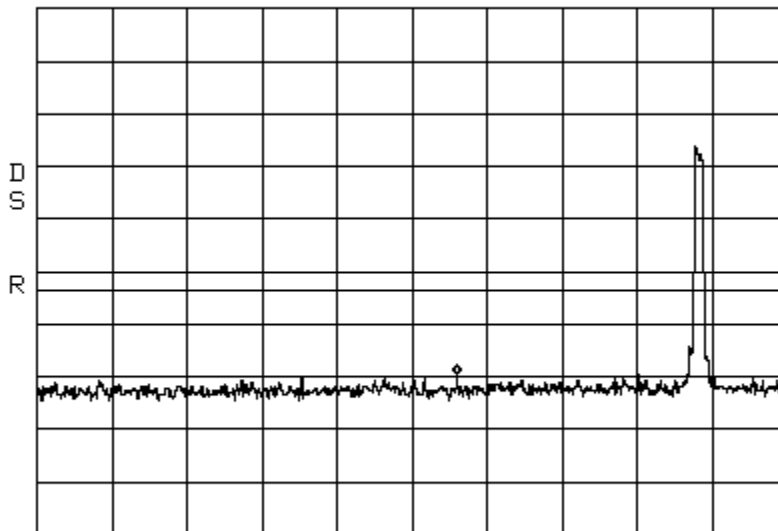

START 30.0MHz STOP 1.0000GHz
*RBW 300kHz *VBW 300kHz SWP 50ms

Intermodulation LTE 5 MHz Channel Bandwidth _High Spectrum CELL
Span: 1 GHz to 10 GHz RBW/VBW: 1 MHz

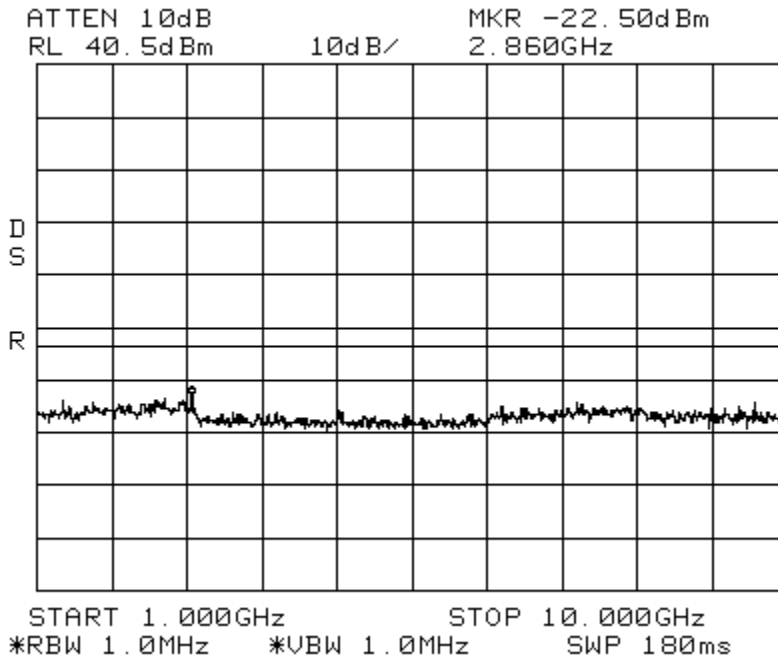

Intermodulation LTE 5 MHz Channel Bandwidth _Apart Spectrum CELL
Center: 881.5 MHz Span: 70 MHz RBW/VBW: 100 kHz

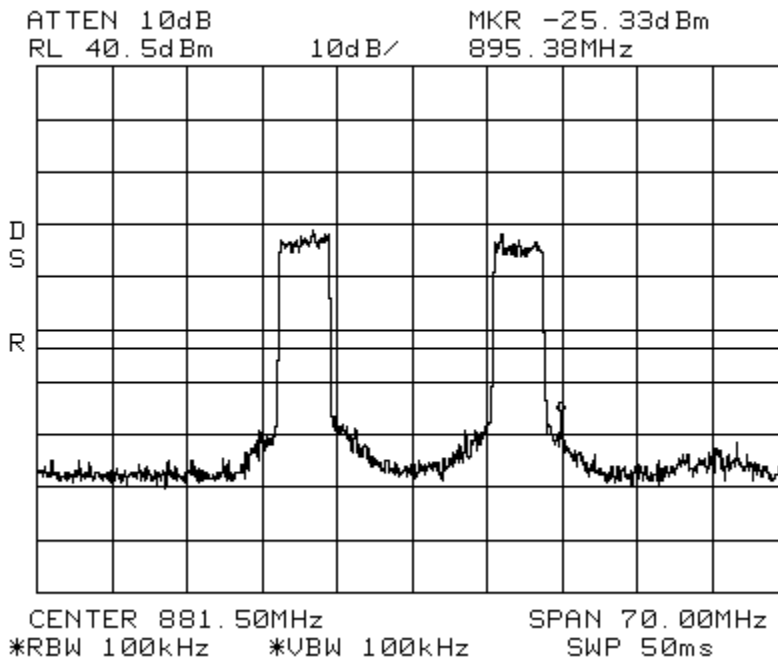

Intermodulation LTE 5 MHz Channel Bandwidth _Apart Spectrum CELL
Span: 30 MHz to 1 GHz RBW/VBW: 300 kHz

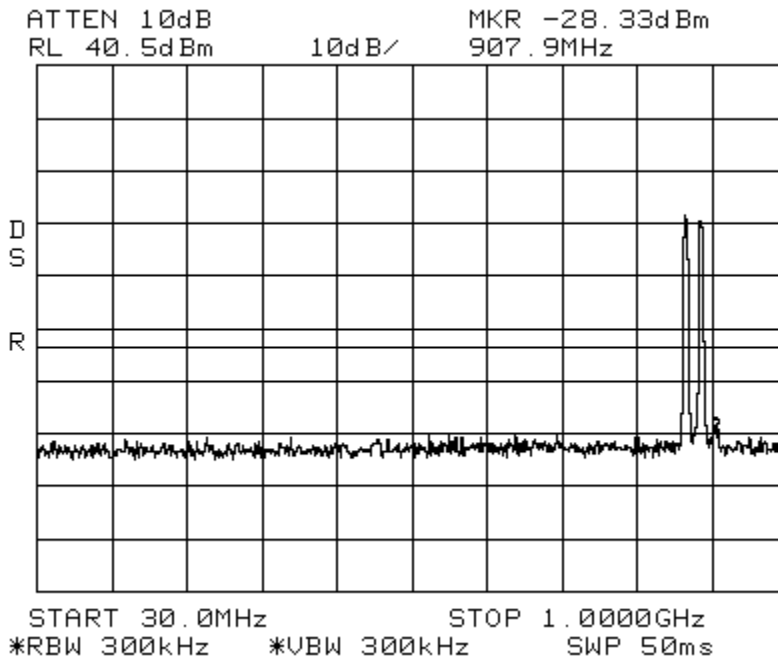

Intermodulation LTE 5 MHz Channel Bandwidth _Apart Spectrum CELL
Span: 1 GHz to 10 GHz RBW/VBW: 1 MHz

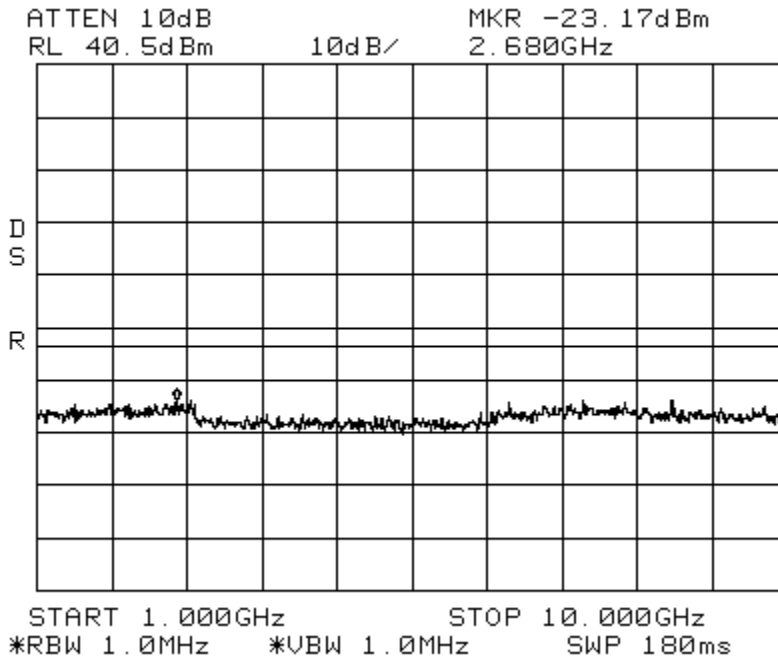

Intermodulation LTE 10 MHz Channel Bandwidth **Low** Spectrum CELL
 Center: 881.5 MHz Span: 70 MHz RBW/VBW: 100 kHz
 ATTN 10dB MKR -26.50dBm
 RL 40.5dBm 10dB/ 867.97MHz

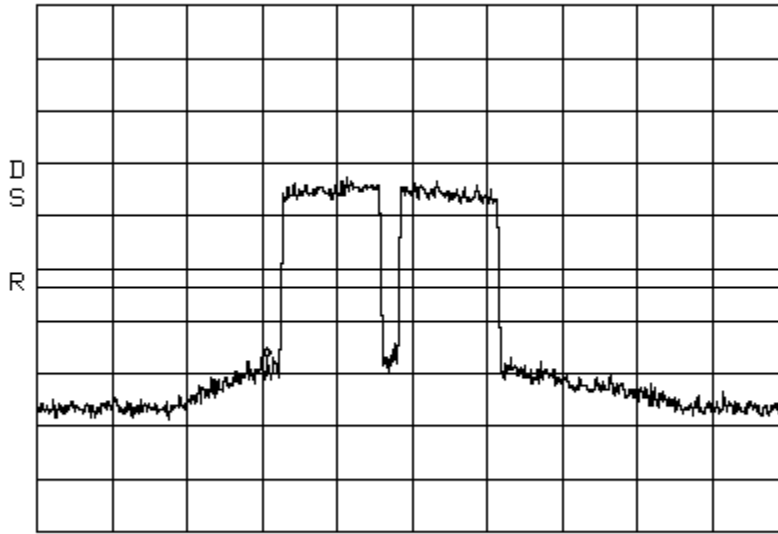

CENTER 881.50MHz SPAN 70.00MHz
 *RBW 100kHz *VBW 100kHz SWP 50ms

Intermodulation LTE 10 MHz Channel Bandwidth **Low** Spectrum CELL
 Span: 30 MHz to 1 GHz RBW/VBW: 300 kHz

ATTN 10dB MKR -30.17dBm
 RL 40.5dBm 10dB/ 752.7MHz

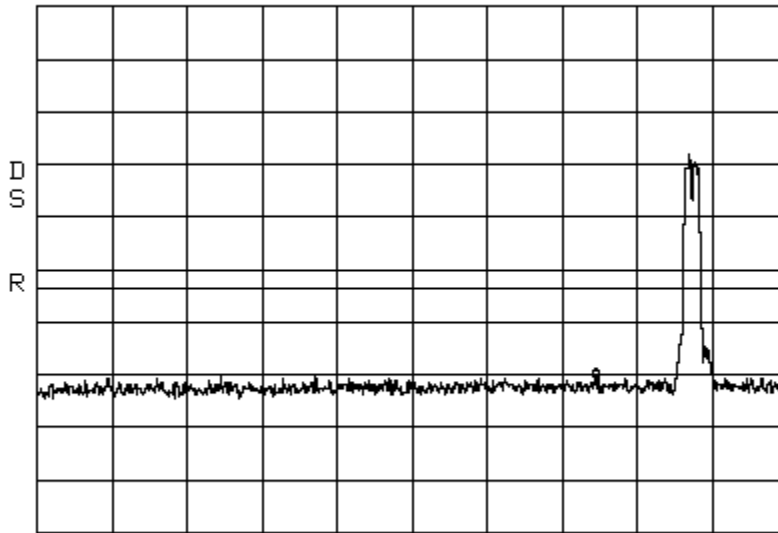

START 30.0MHz STOP 1.0000GHz
 *RBW 300kHz *VBW 300kHz SWP 50ms

Intermodulation LTE 10 MHz Channel Bandwidth _Low Spectrum CELL
Span: 1 GHz to 10GHz RBW/VBW: 1 MHz

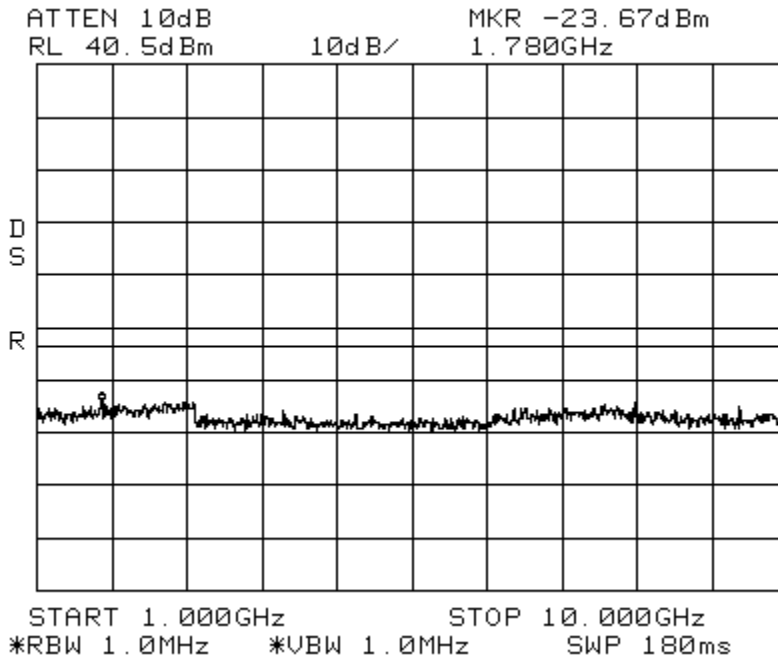

Intermodulation LTE 10 MHz Channel Bandwidth _High Spectrum CELL
Center: 881.5 MHz Span: 70 MHz RBW/VBW: 100 kHz

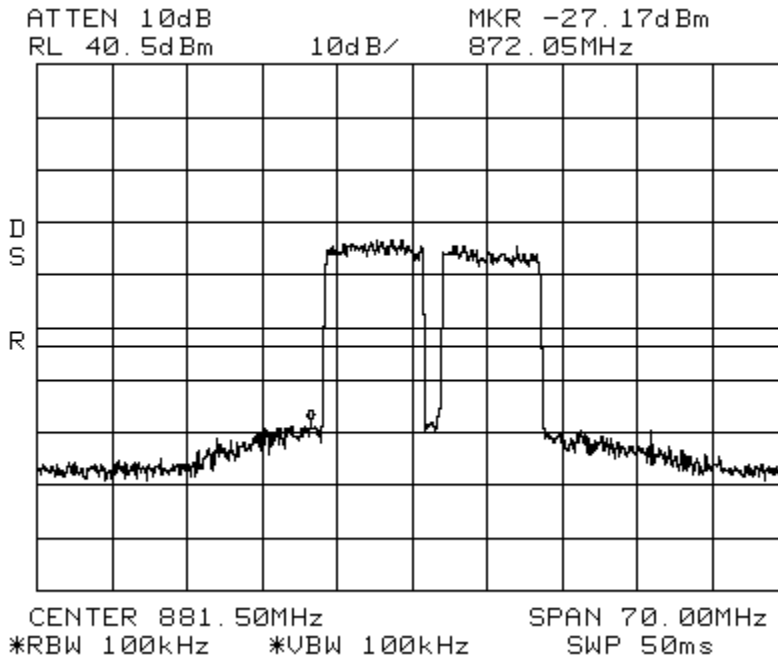

Intermodulation LTE 10 MHz Channel Bandwidth_High Spectrum CELL
Span: 30 MHz to 1 GHz RBW/VBW: 300 kHz

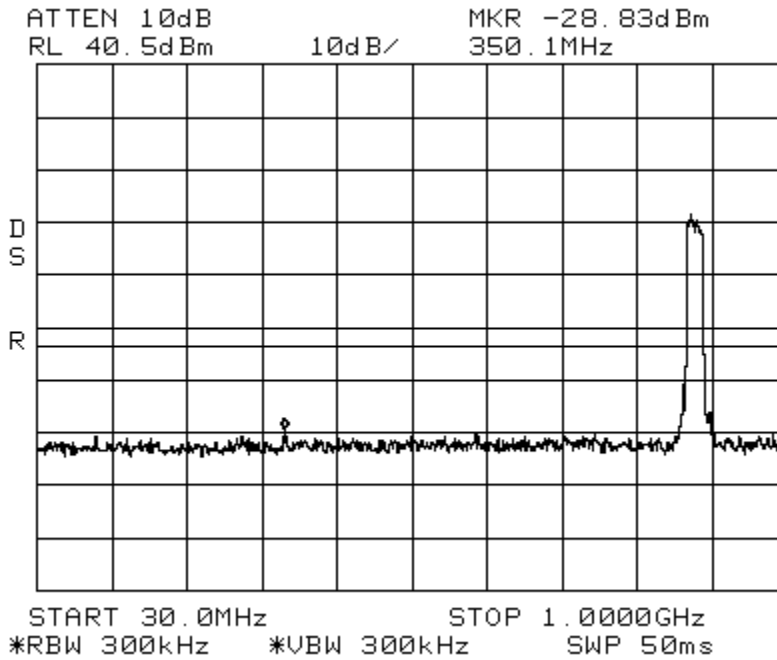

Intermodulation LTE 10 MHz Channel Bandwidth_High Spectrum CELL
Span: 1 GHz to 10 GHz RBW/VBW: 1 MHz

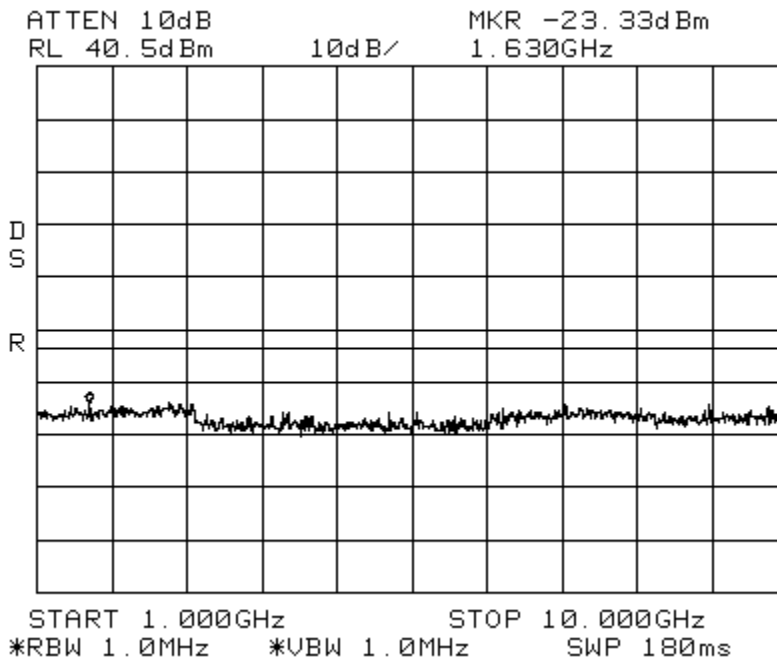

Intermodulation LTE 10 MHz Channel Bandwidth _Apart Spectrum CELL
 Center: 881.5 MHz Span: 175 MHz RBW/VBW: 100 kHz
 ATTEN 10dB MKR -26.67dBm
 RL 40.5dBm 10dB/ 895.5MHz

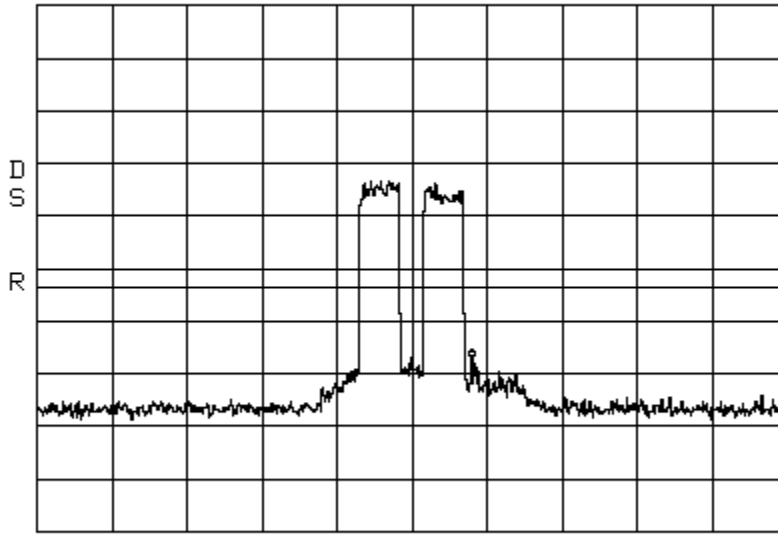

CENTER 881.5MHz SPAN 175.0MHz
 *RBW 100kHz *VBW 100kHz SWP 50ms

Intermodulation LTE 10 MHz Channel Bandwidth _Apart Spectrum CELL
 Span: 30 MHz to 1 GHz RBW/VBW: 300 kHz

ATTEN 10dB MKR -28.33dBm
 RL 40.5dBm 10dB/ 951.5MHz

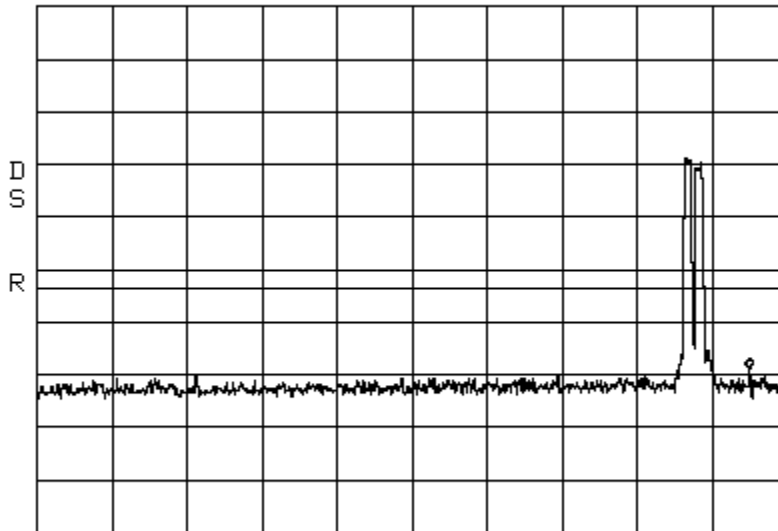

START 30.0MHz STOP 1.0000GHz
 *RBW 300kHz *VBW 300kHz SWP 50ms

Intermodulation LTE 10 MHz Channel Bandwidth_Apart Spectrum CELL
Span: 1 GHz to 10 GHz RBW/VBW: 1 MHz

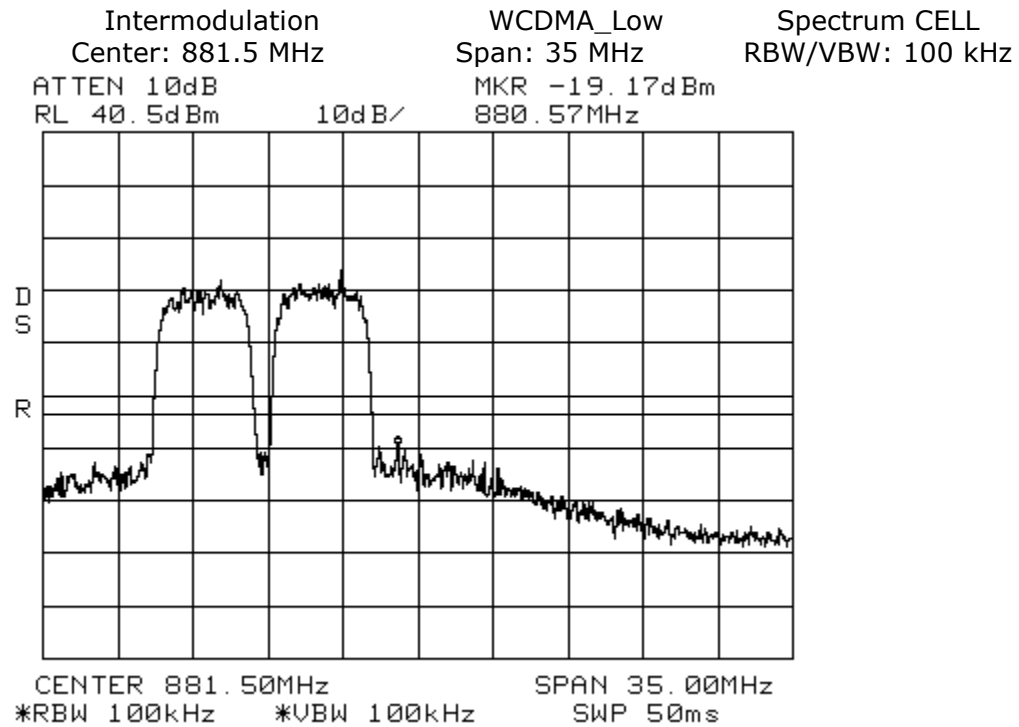
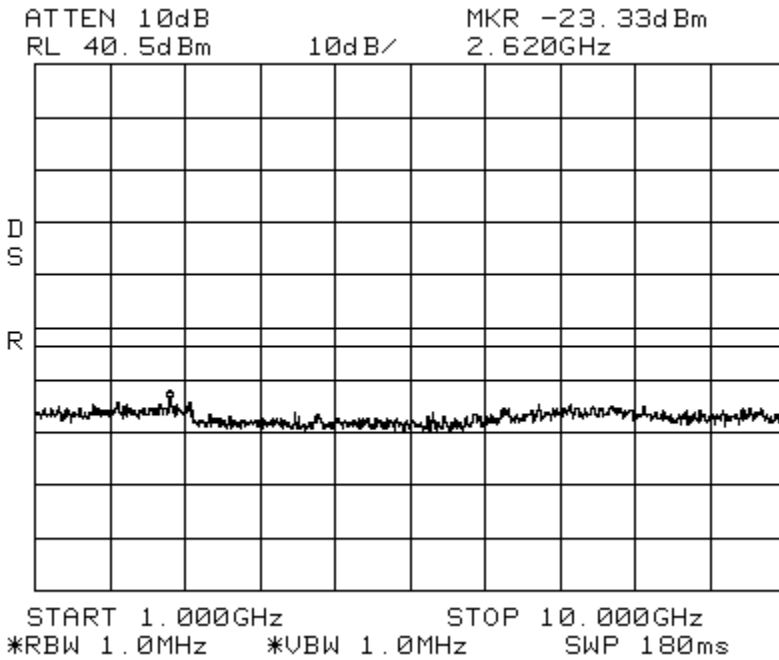

Intermodulation WCDMA_Low Spectrum CELL
Span: 30 MHz to 1 GHz RBW/VBW: 300 kHz

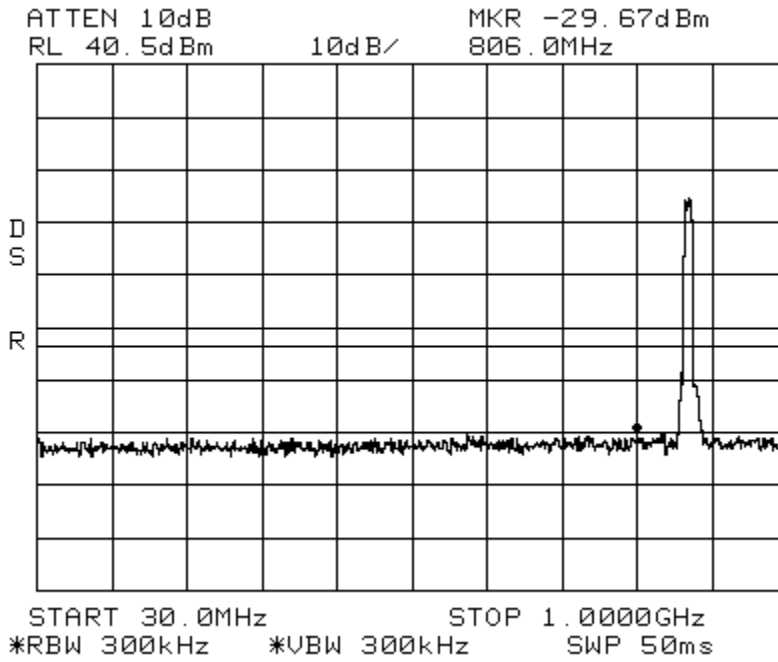

Intermodulation WCDMA_Low Spectrum CELL
Span: 1 GHz to 10 GHz RBW/VBW: 1 MHz

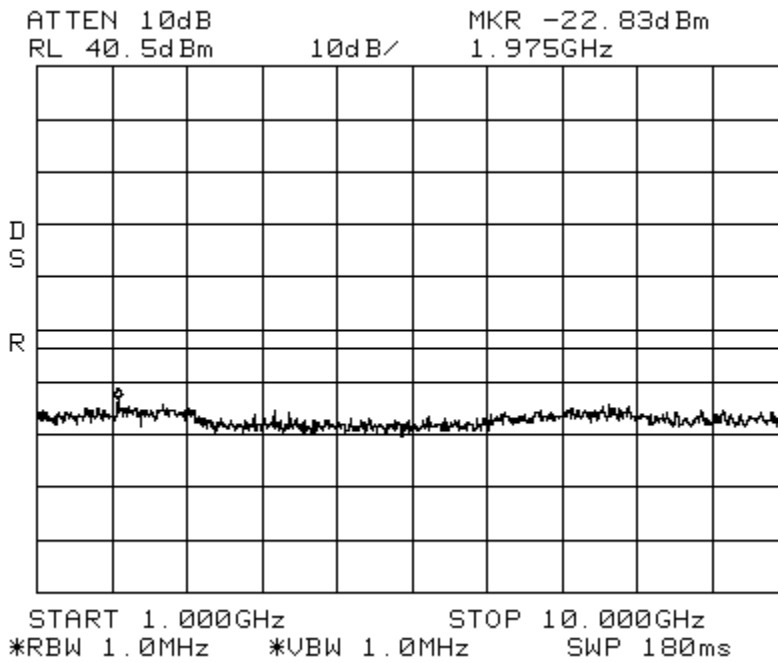

Intermodulation WCDMA_High Spectrum CELL
 Center: 881.5 MHz Span: 35 MHz RBW/VBW: 100 kHz
 ATTN 10dB MKR -23.83dBm
 RL 40.5dBm 10dB/ 881.68MHz

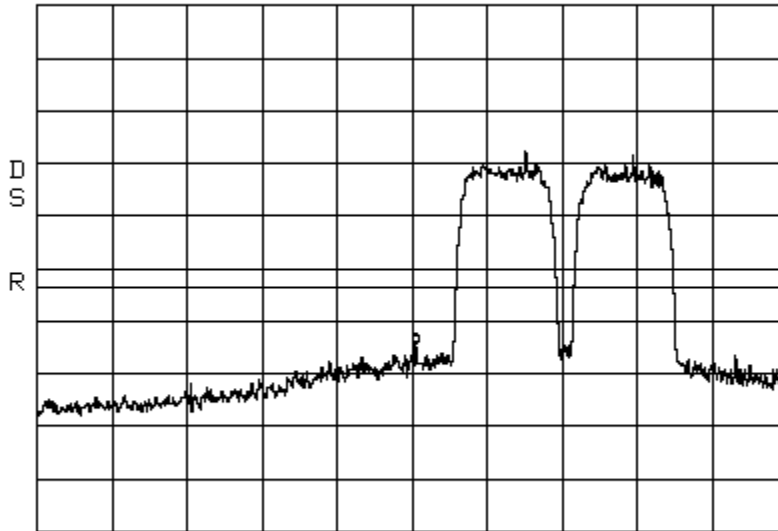

CENTER 881.50MHz SPAN 35.00MHz
 *RBW 100kHz *VBW 100kHz *SWP 180ms

Intermodulation WCDMA_High Spectrum CELL
 Span: 30 MHz to 1 GHz RBW/VBW: 300 kHz

ATTEN 10dB MKR -29.33dBm
 RL 40.5dBm 10dB/ 621.7MHz

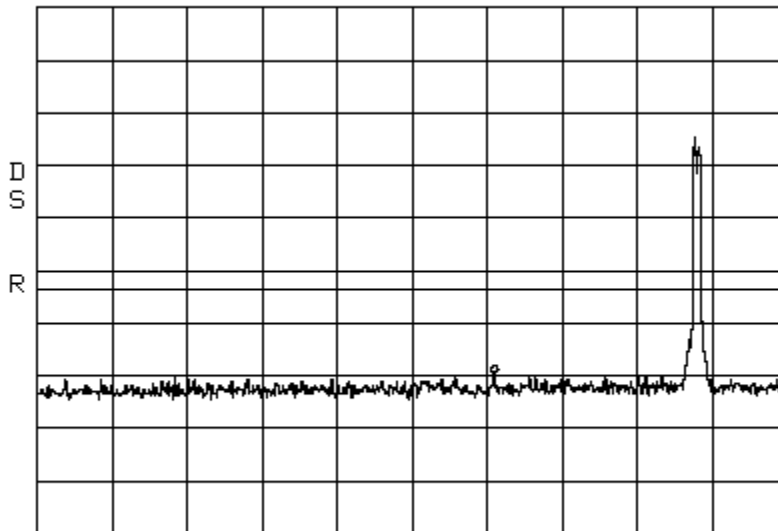

START 30.0MHz STOP 1.0000GHz
 *RBW 300kHz *VBW 300kHz *SWP 180ms

Intermodulation WCDMA_High Spectrum CELL
Span: 1 GHz to 10 GHz RBW/VBW: 1 MHz

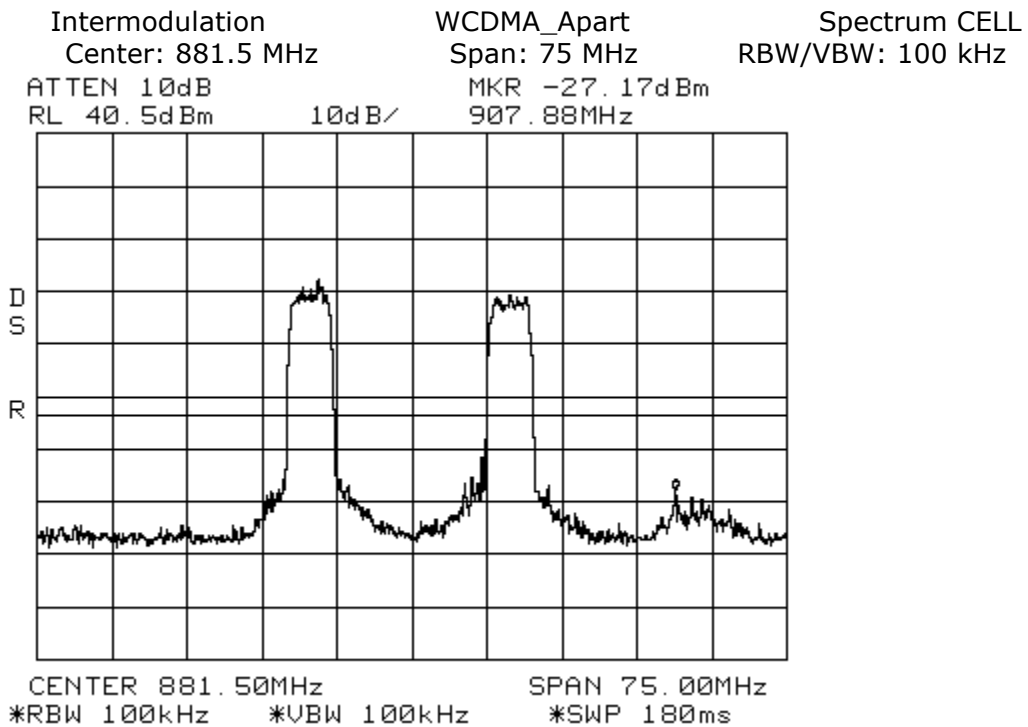
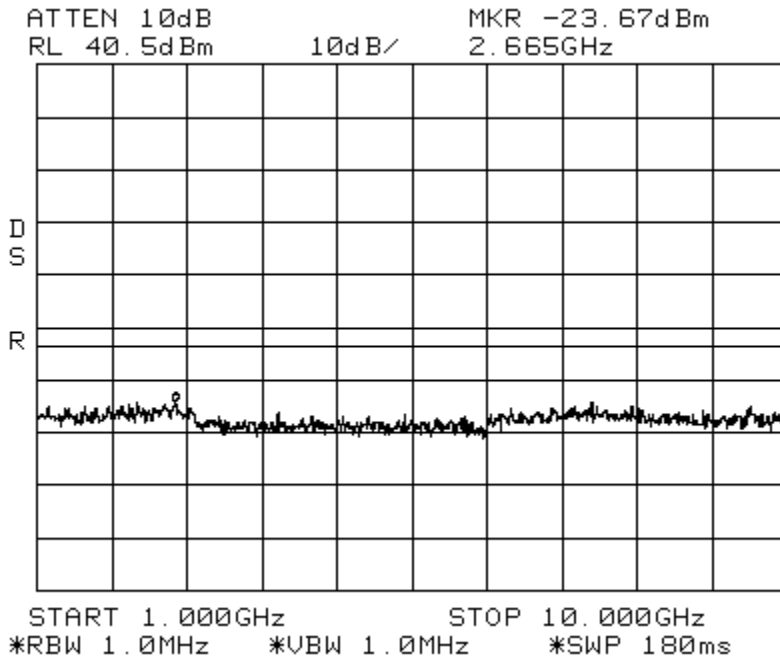

Intermodulation

WCDMA_Apart

Spectrum CELL

Span: 30 MHz to 1 GHz

RBW/VBW: 300 kHz

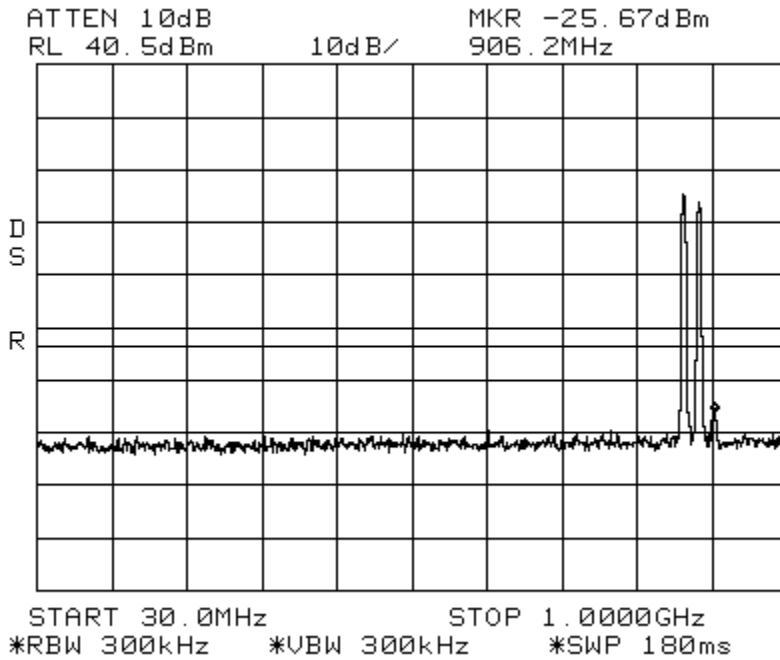

Intermodulation

WCDMA_Apart

Spectrum CELL

Span: 1 GHz to 10 GHz

RBW/VBW: 1 MHz

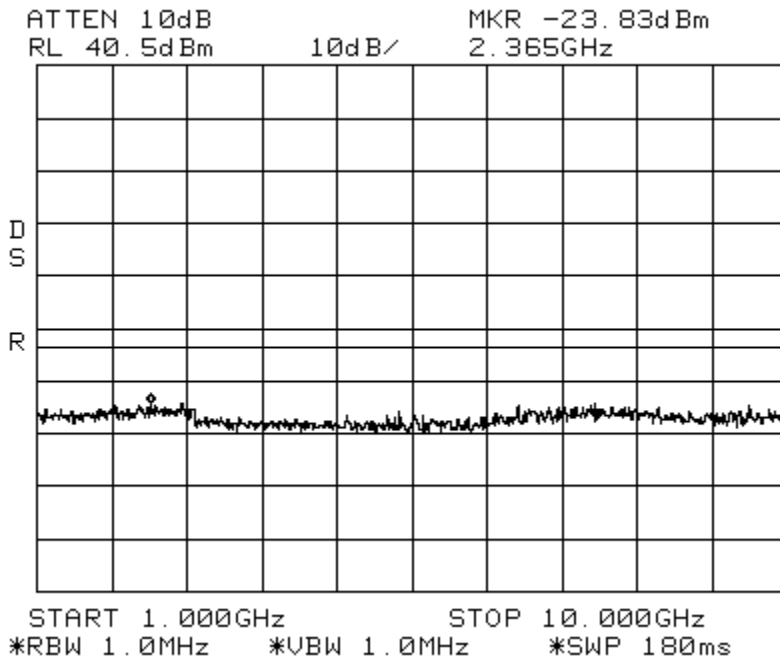

Intermodulation CDMA_Low Spectrum PCS Path 1
 Center: 1962.5 MHz Span: 90 MHz RBW/VBW: 100 kHz
 ATTEN 10dB MKR -24.50dBm
 RL 40.5dBm 10dB/ 1.92770GHz

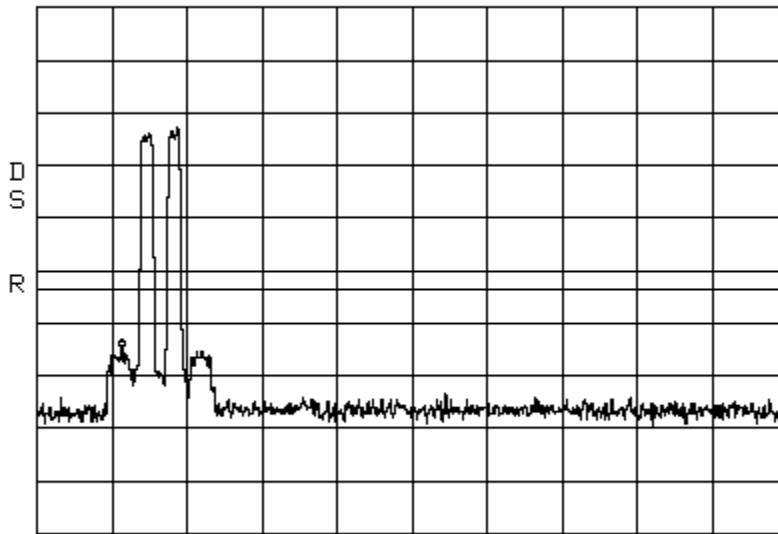

CENTER 1.96250GHz SPAN 90.00MHz
 *RBW 100kHz *VBW 100kHz SWP 50ms

Intermodulation CDMA_Low Spectrum PCS Path 1
 Span: 30 MHz to 1 GHz RBW/VBW: 300 kHz

ATTEN 10dB MKR -28.50dBm
 RL 40.5dBm 10dB/ 982.2MHz

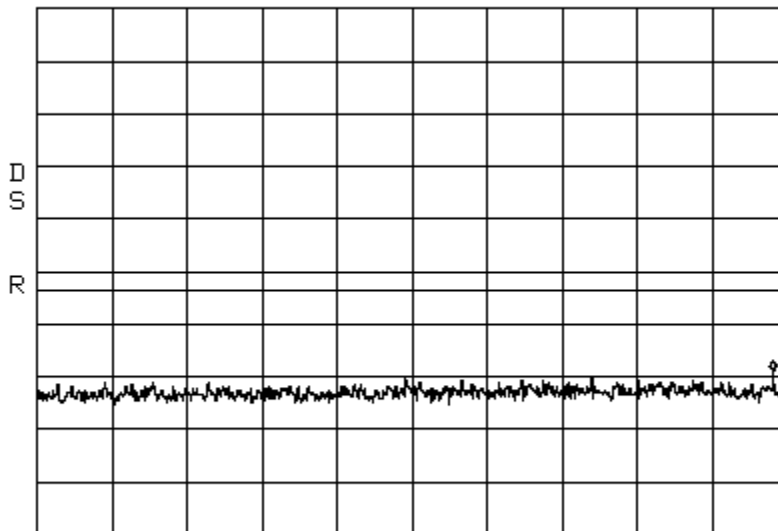

START 30.0MHz STOP 1.0000GHz
 *RBW 300kHz *VBW 300kHz SWP 50ms

Intermodulation CDMA_High Spectrum PCS Path 1
Span: 30 MHz to 1 GHz RBW/VBW: 300 kHz

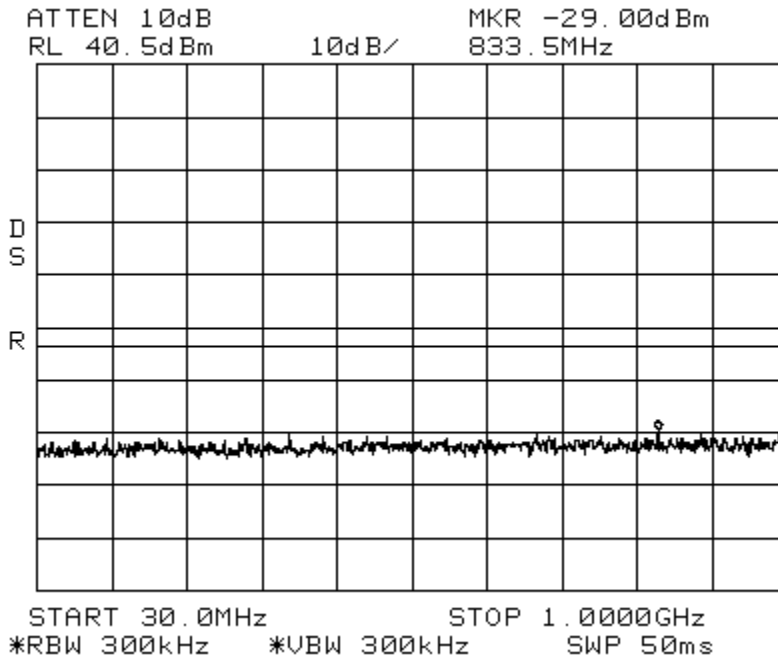

Intermodulation CDMA_High Spectrum PCS Path 1
Span: 1 GHz to 20 GHz RBW/VBW: 1 MHz

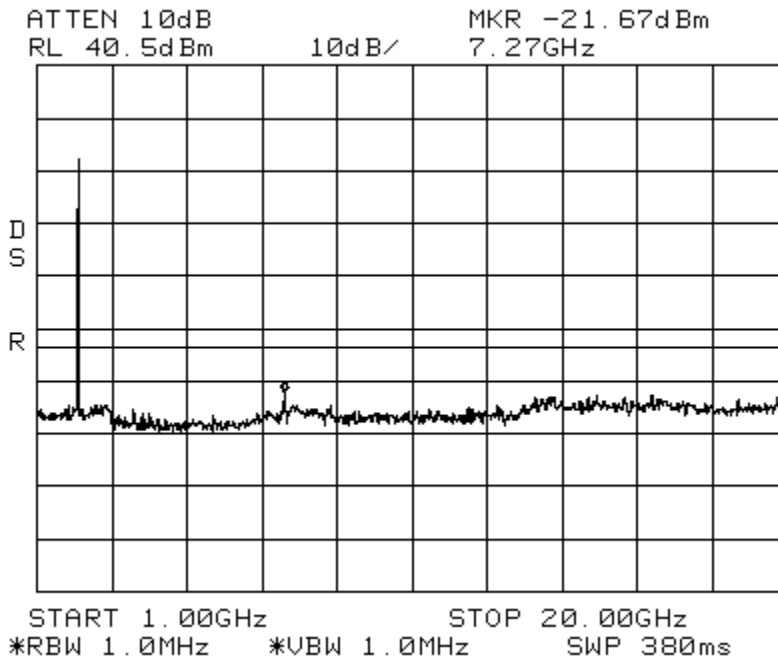

Intermodulation CDMA_Apart Spectrum PCS Path 1
Center: 1962.5 MHz Span: 175 MHz RBW/VBW: 100 kHz
ATTEN 10dB MKR -32.33dBm
RL 40.5dBm 10dB/ 1.9736GHz

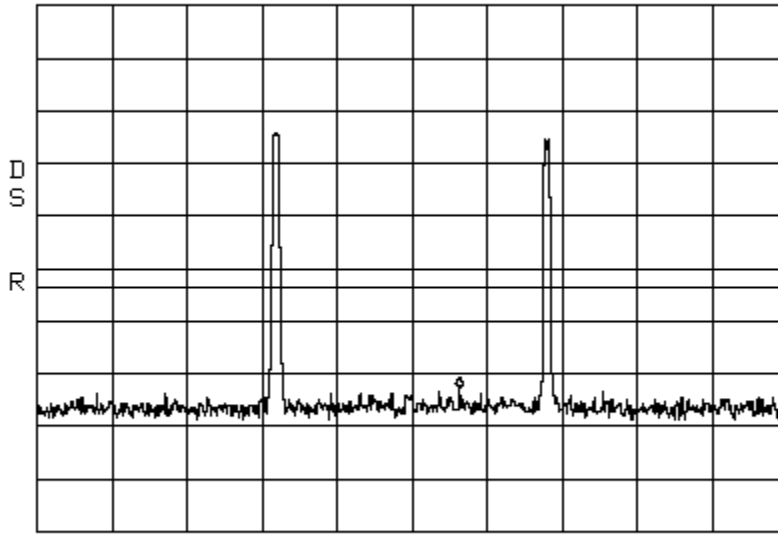

CENTER 1.9625GHz SPAN 175.0MHz
*RBW 100kHz *VBW 100kHz SWP 50ms

Intermodulation CDMA_Apart Spectrum PCS Path 1
Span: 30 MHz to 1 GHz RBW/VBW: 300 kHz

ATTEN 10dB MKR -28.83dBm
RL 40.5dBm 10dB/ 846.4MHz

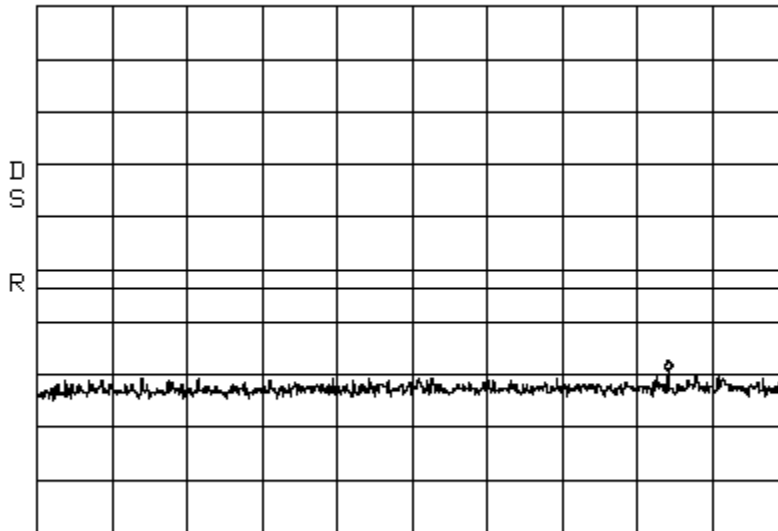

START 30.0MHz STOP 1.0000GHz
*RBW 300kHz *VBW 300kHz SWP 50ms

Intermodulation CDMA_Apart Spectrum PCS Path 1
Span: 1 GHz to 20 GHz RBW/VBW: 1 MHz

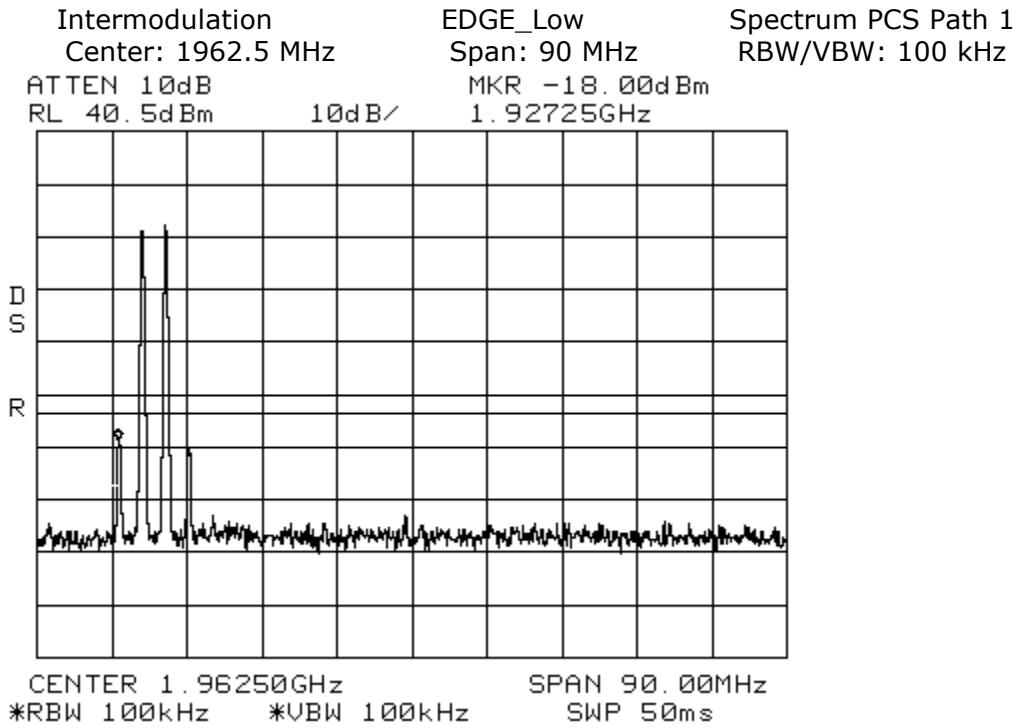
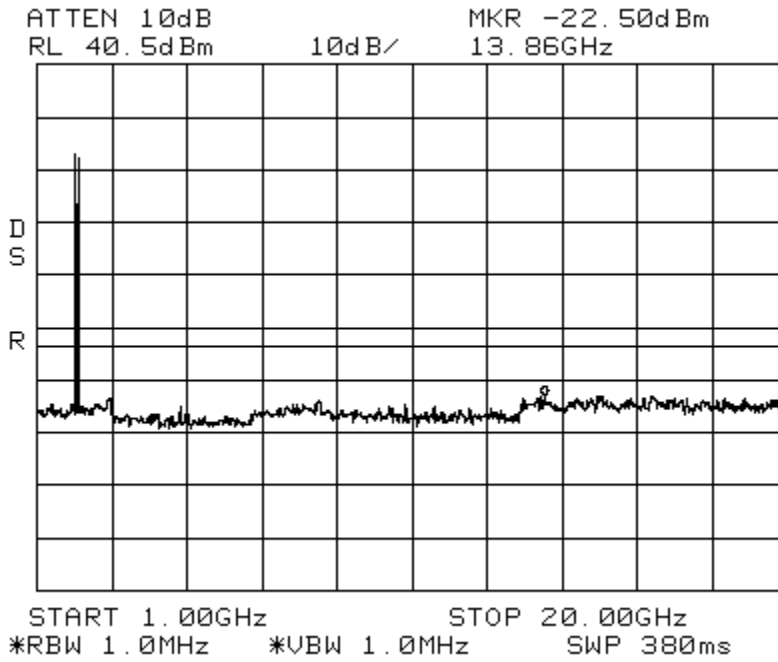

Intermodulation
Start: 1924MHz

EDGE_Low
Stop: 1929 MHz

Spectrum PCS Path 1
RBW/VBW: 1 MHz



RBW: 1 MHz
VBW: 1 MHz
Marker 2 [T1]
-15.88 dBm
SWT: 2.0 ms
1.929000000 GHz

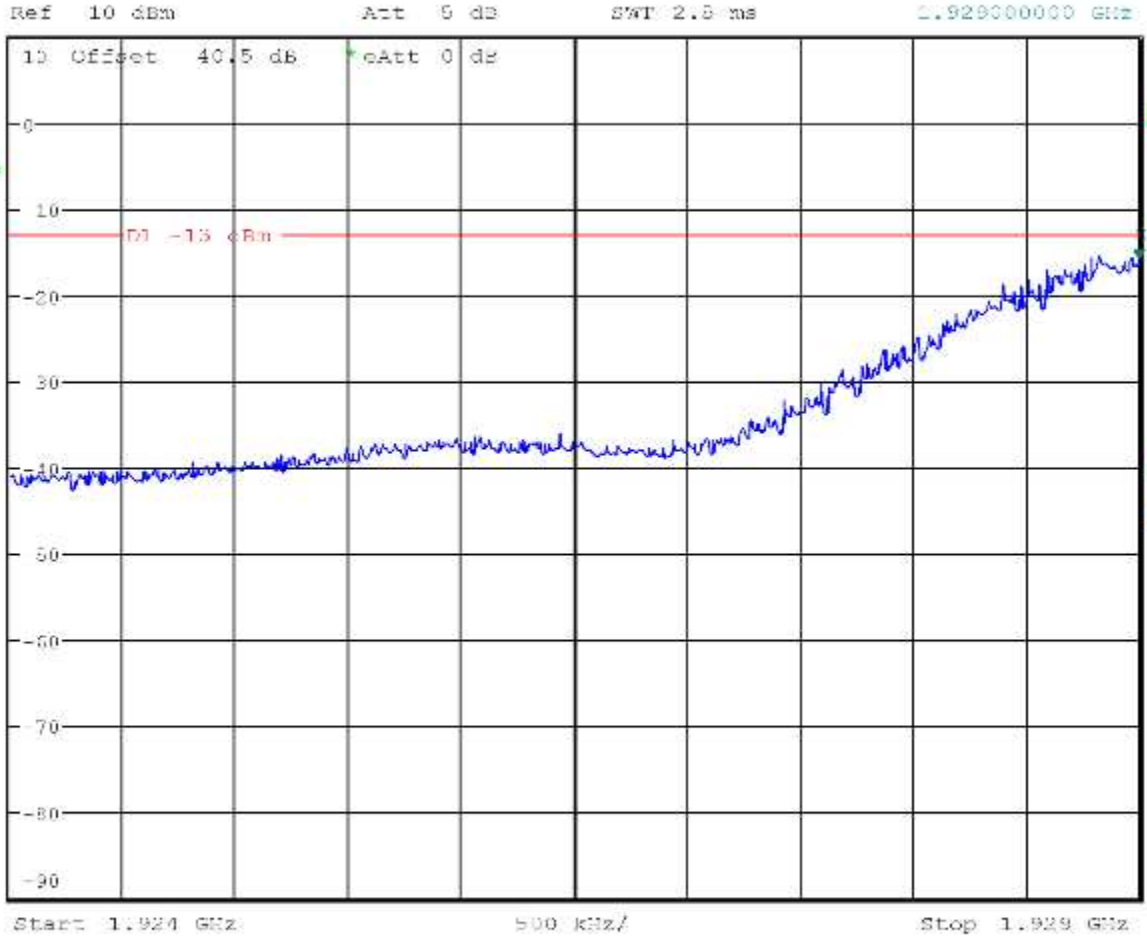

Date: 10.JUL.2012 09:42:43

Intermodulation

EDGE_Low

Spectrum PCS Path 1

Span: 30 MHz to 1 GHz

RBW/VBW: 300 kHz

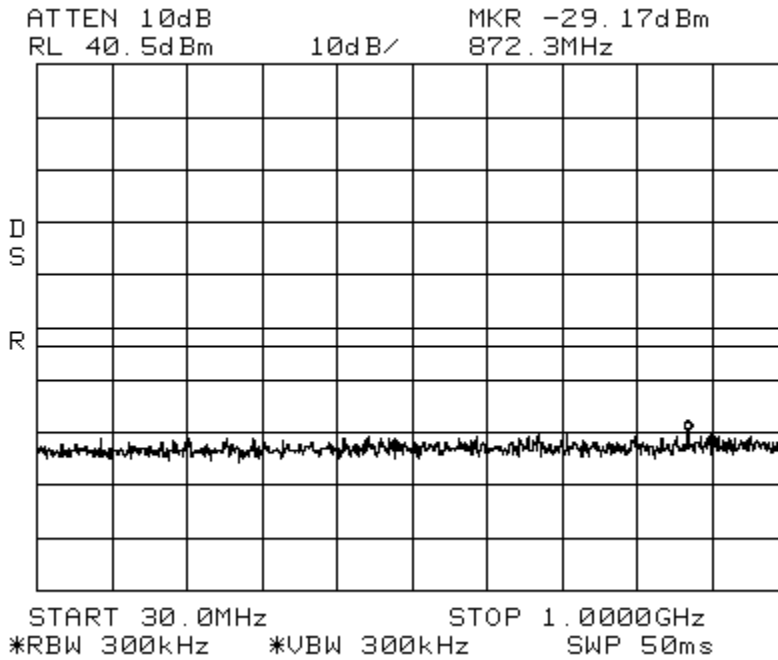

Intermodulation

EDGE_Low

Spectrum PCS Path 1

Span: 1 GHz to 20 GHz

RBW/VBW: 1 MHz

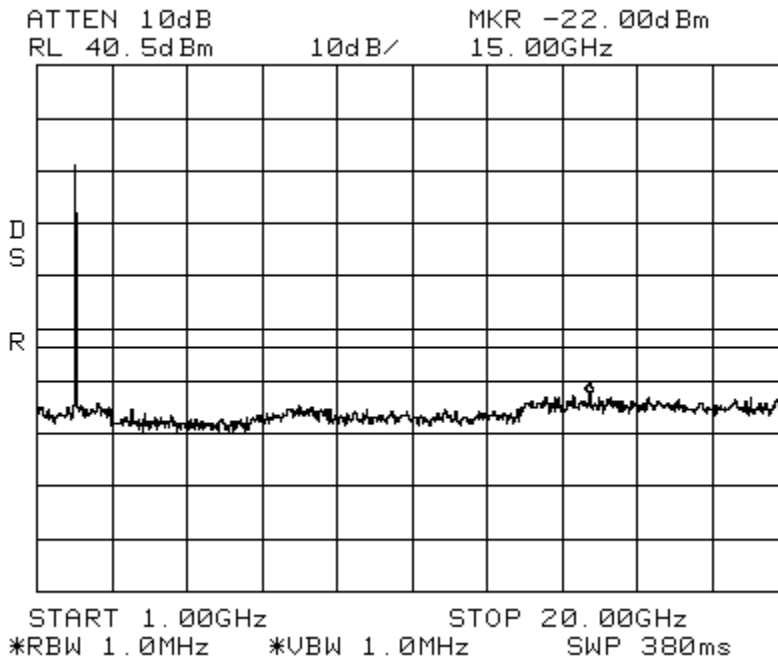

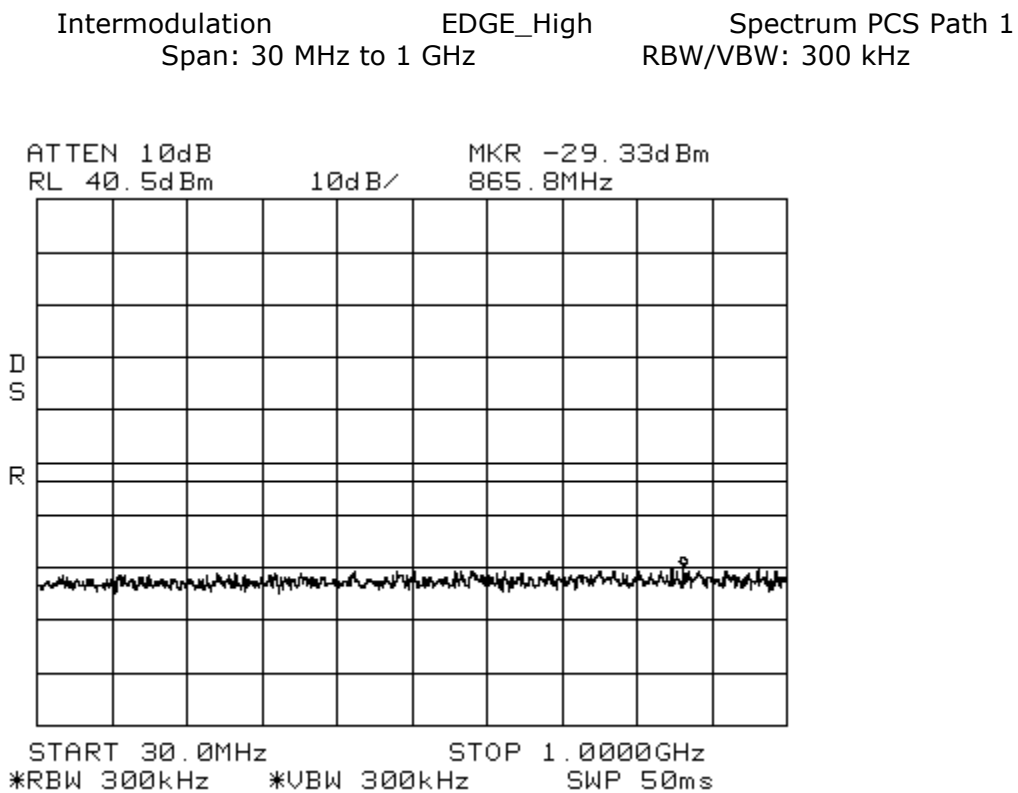
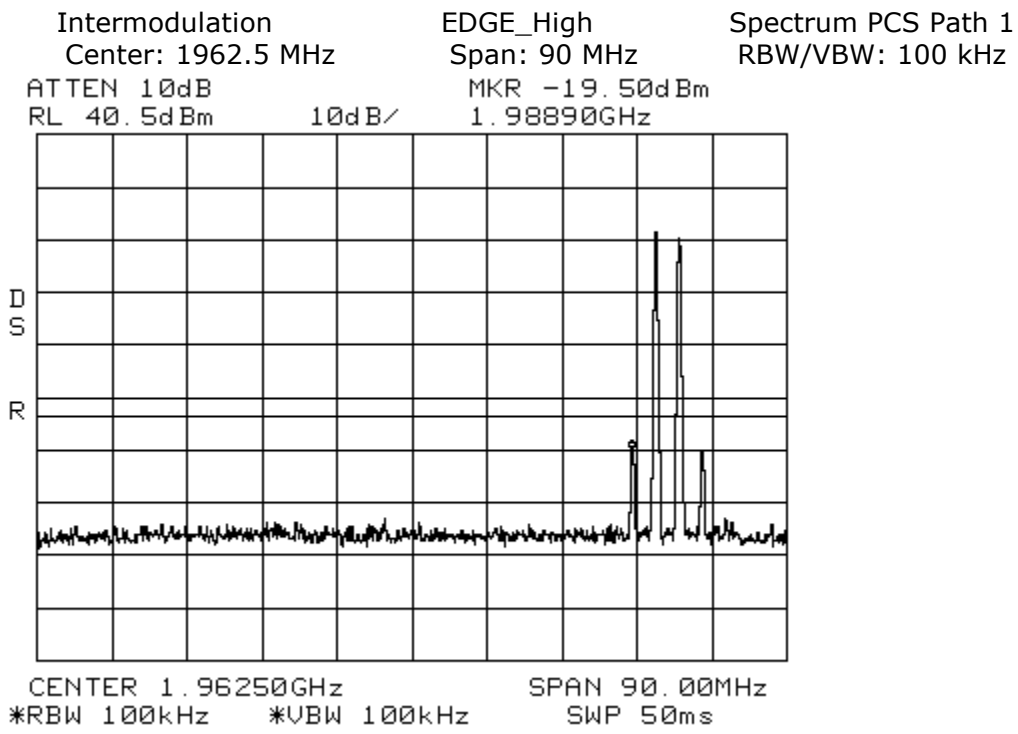

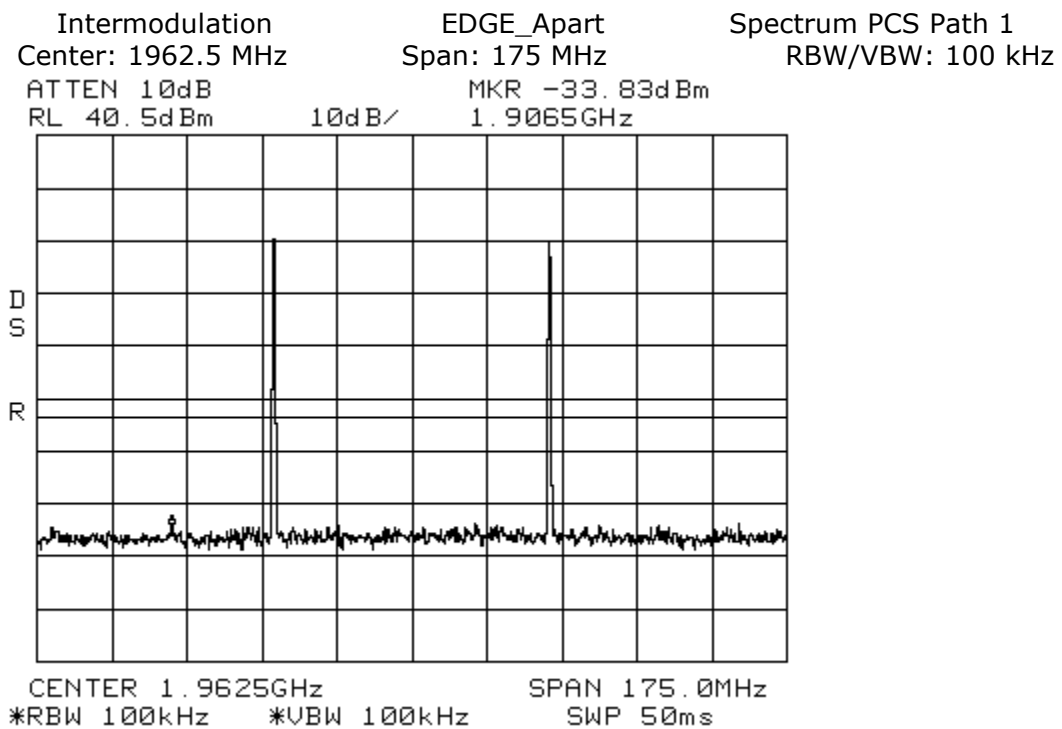
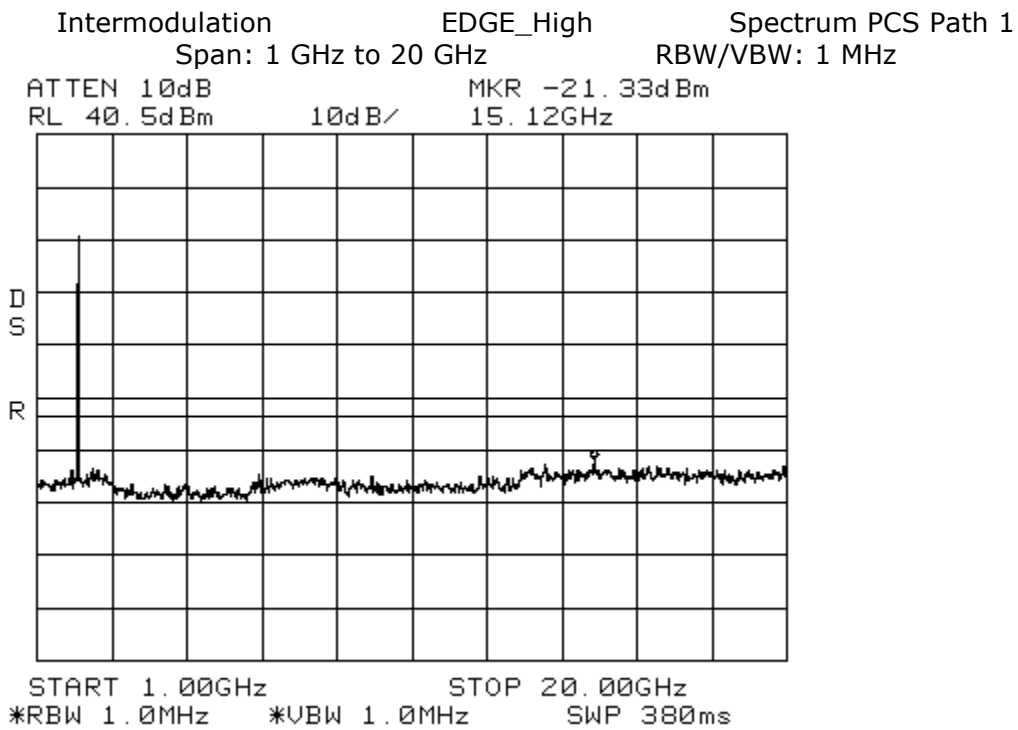

Intermodulation EDGE_Apart Spectrum PCS Path 1
Span: 30 MHz to 1 GHz RBW/VBW: 300 kHz

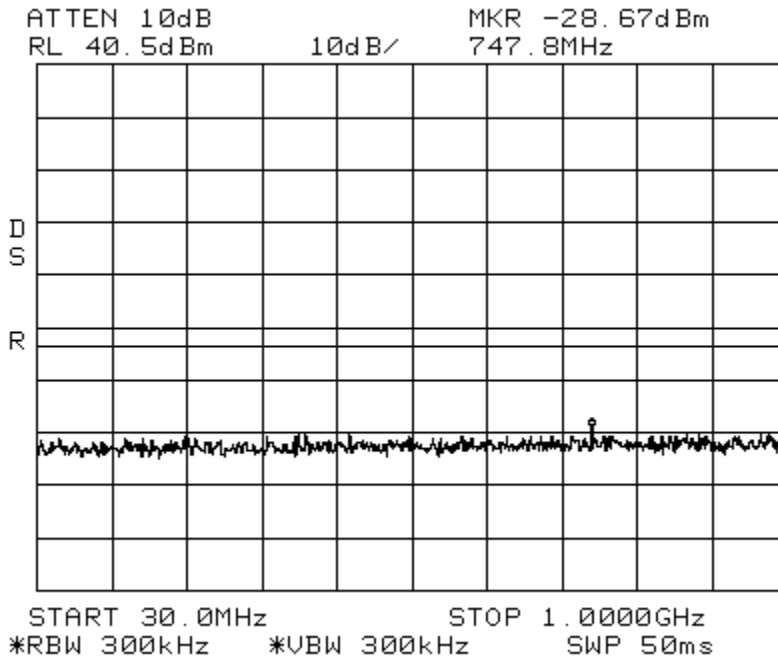

Intermodulation EDGE_Apart Spectrum PCS Path 1
Span: 1 GHz to 20 GHz RBW/VBW: 1 MHz

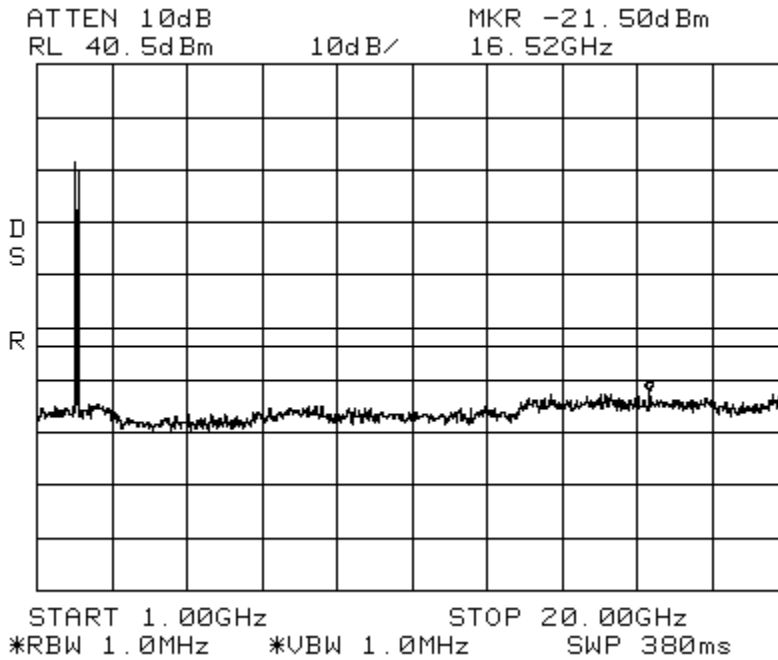

Intermodulation
Center: 1962.5 MHz

GSM_Low
Span: 90 MHz

Spectrum PCS Path 1
RBW/VBW: 100 kHz

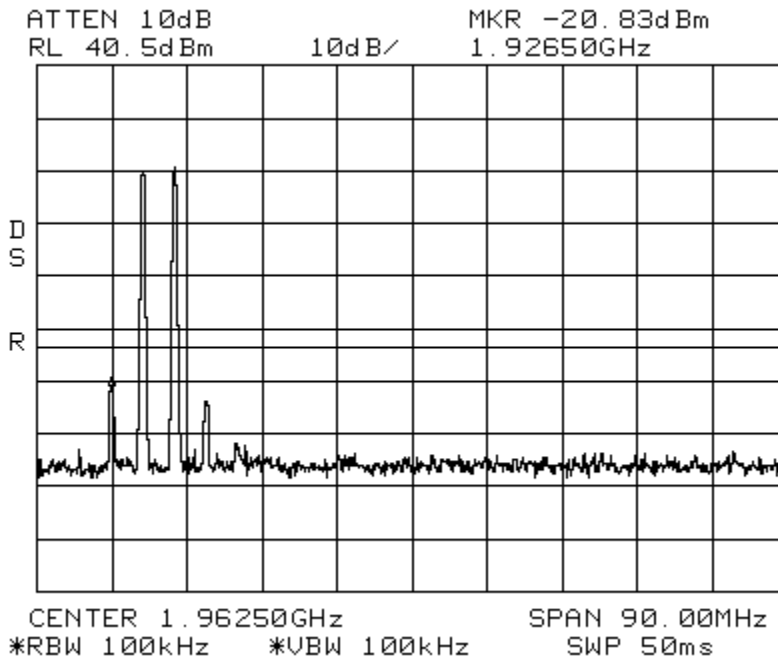

Intermodulation
Start: 1924 MHz Stop: 1929 MHz

GSM_Low

Spectrum PCS Path 1
RBW/VBW: 1 MHz

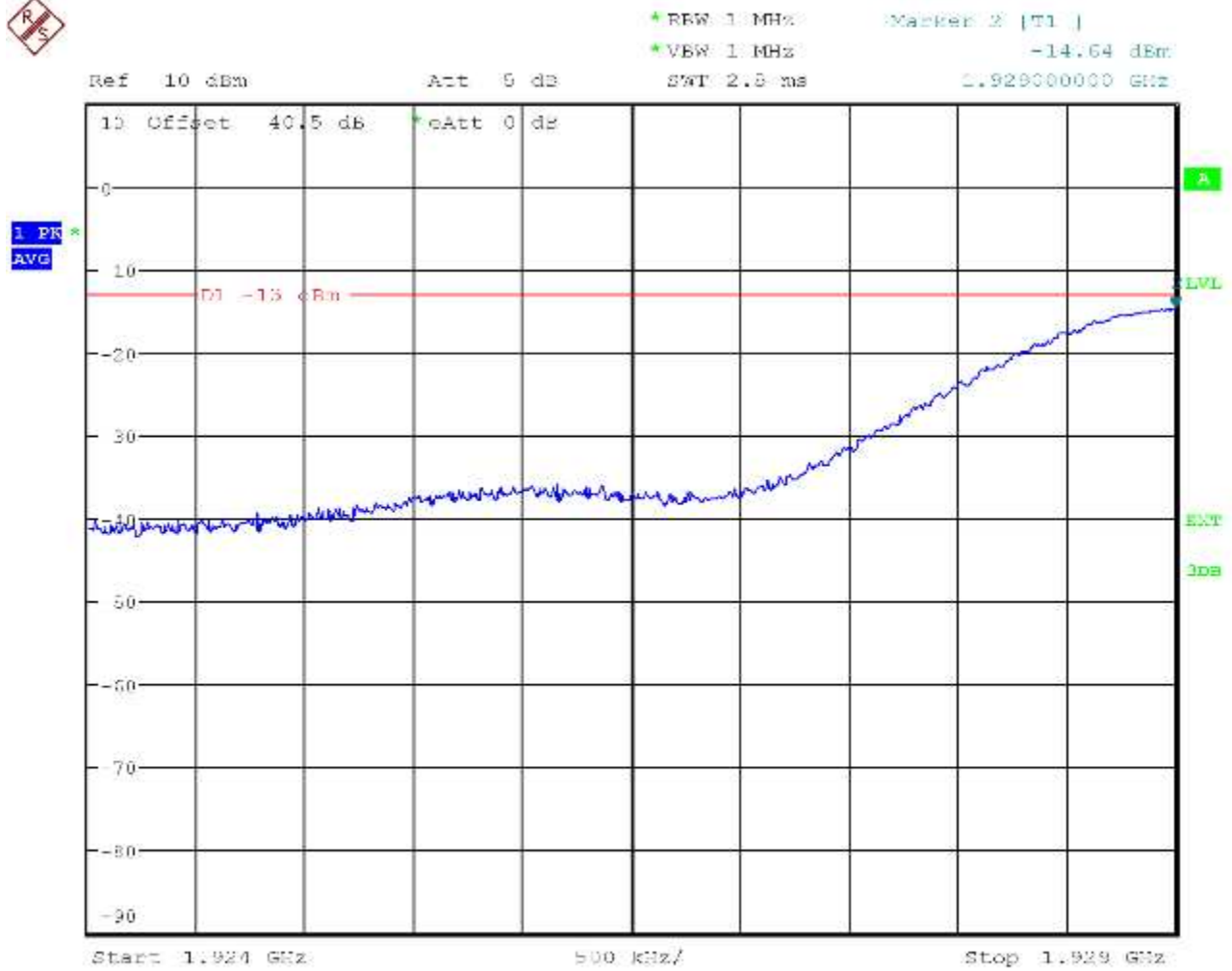

Date: 10.JUL.2012 09:40:39

Intermodulation GSM_Low Spectrum PCS Path 1
Span: 30 MHz to 1 GHz RBW/VBW: 300 kHz

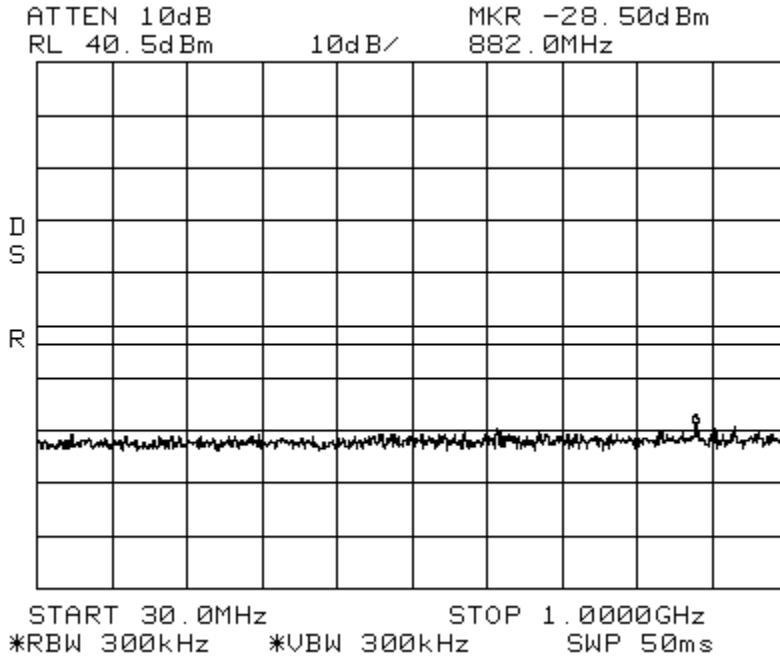

Intermodulation GSM_Low Spectrum PCS Path 1
Span: 1 GHz to 20 GHz RBW/VBW: 1 MHz

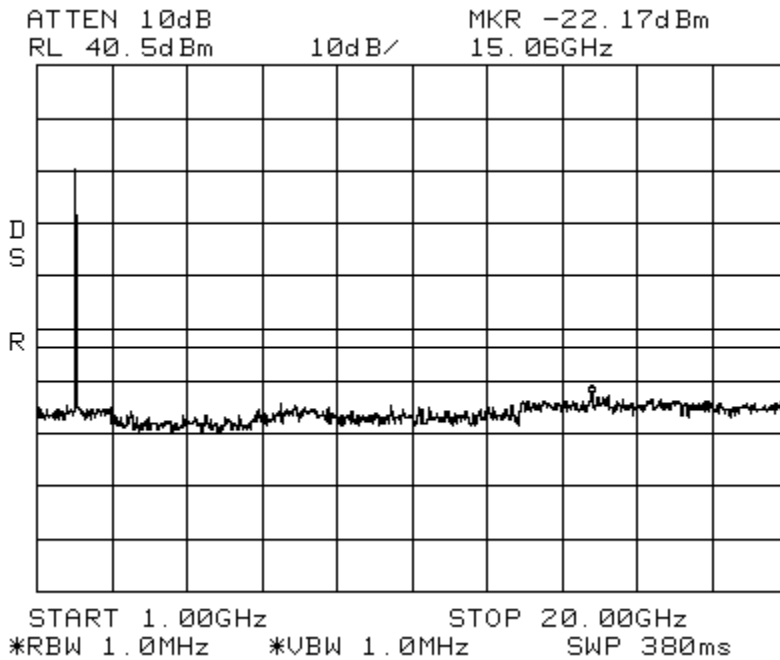

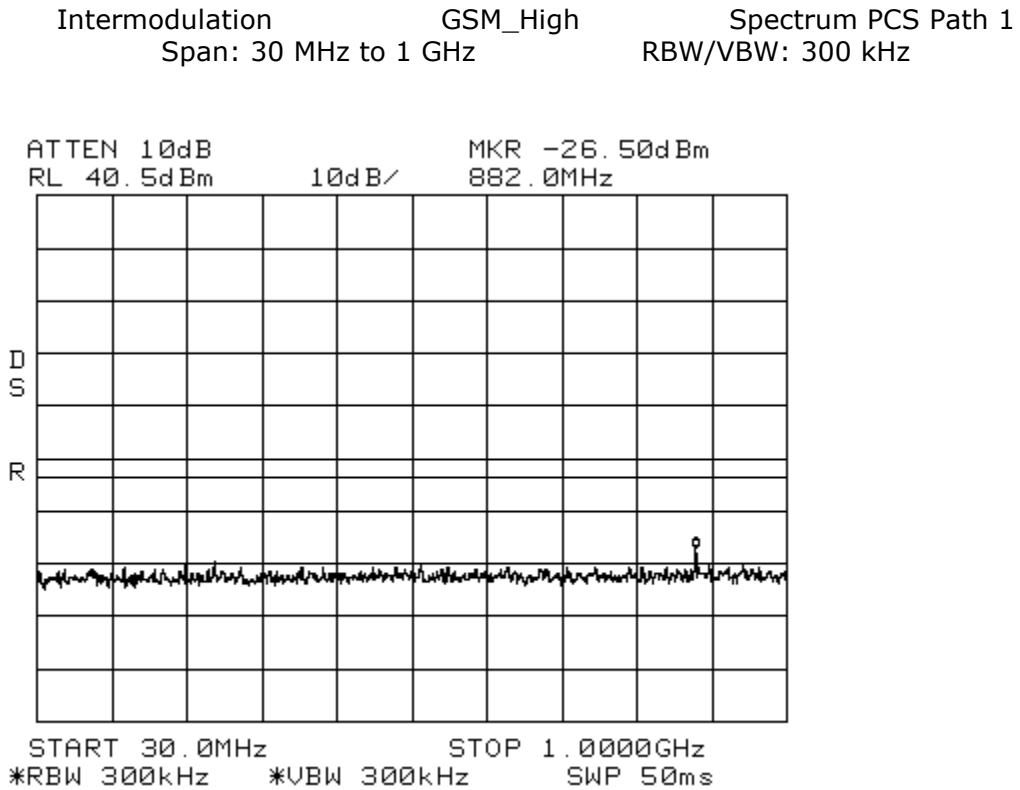
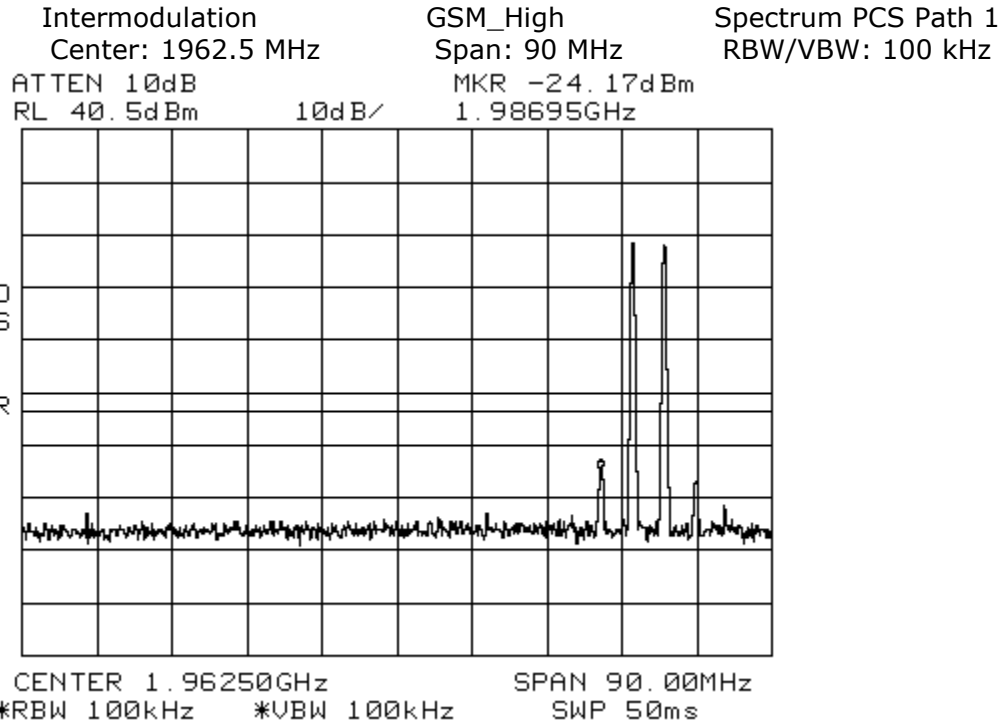

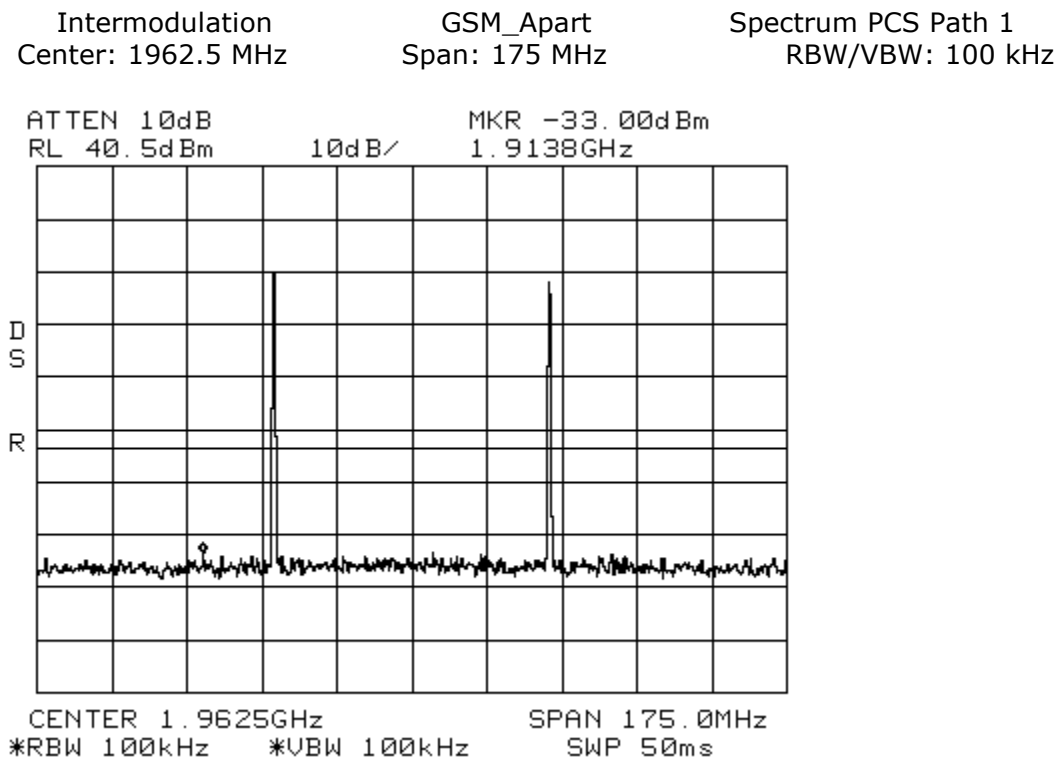
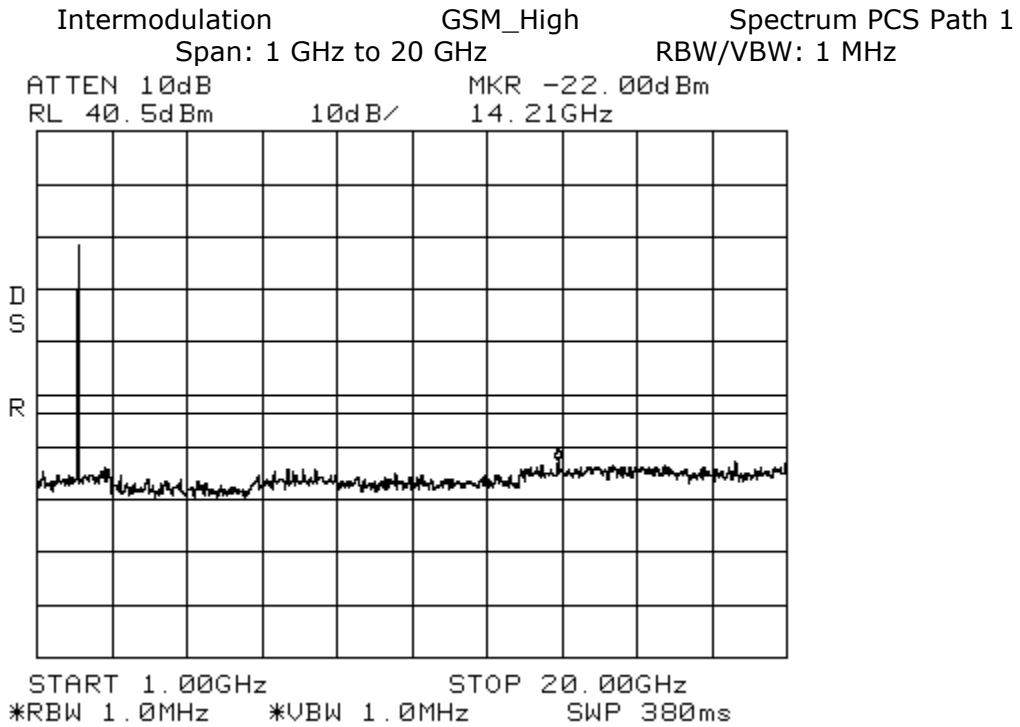

Intermodulation GSM_Apart Spectrum PCS Path 1
Span: 30 MHz to 1 GHz RBW/VBW: 300 kHz

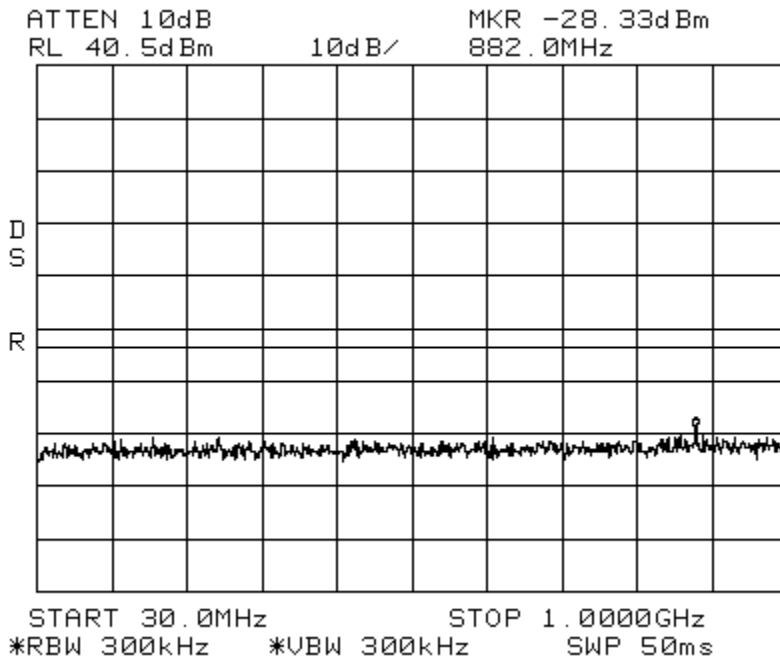

Intermodulation GSM_Apart Spectrum PCS Path 1
Span: 1 GHz to 20 GHz RBW/VBW: 1 MHz

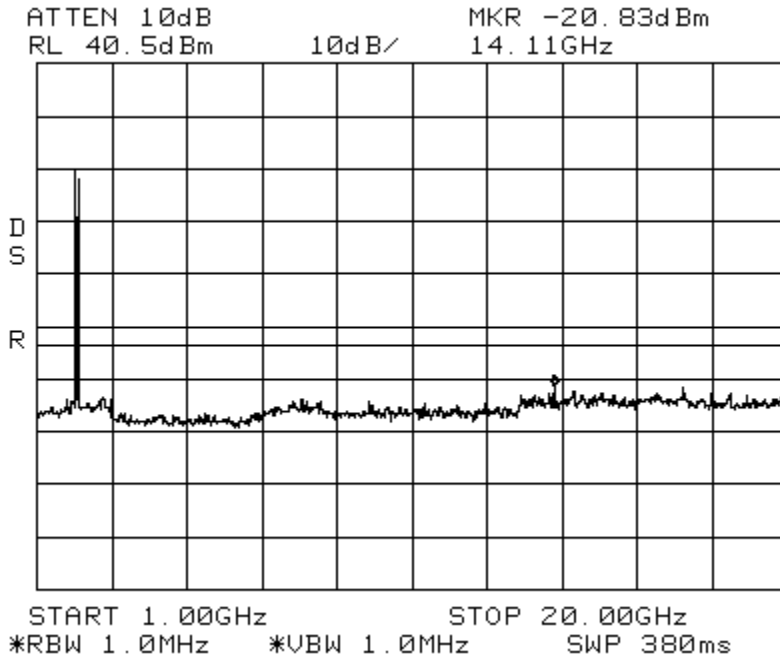

Intermodulation LTE 3 MHz Channel Bandwidth_ **Low** Spectrum PCS
Center: 1962.5 MHz Span: 90 MHz RBW/VBW: 100 kHz

ATTEN 10dB MKR -20.67dBm
RL 40.5dBm 10dB/ 1.94135GHz

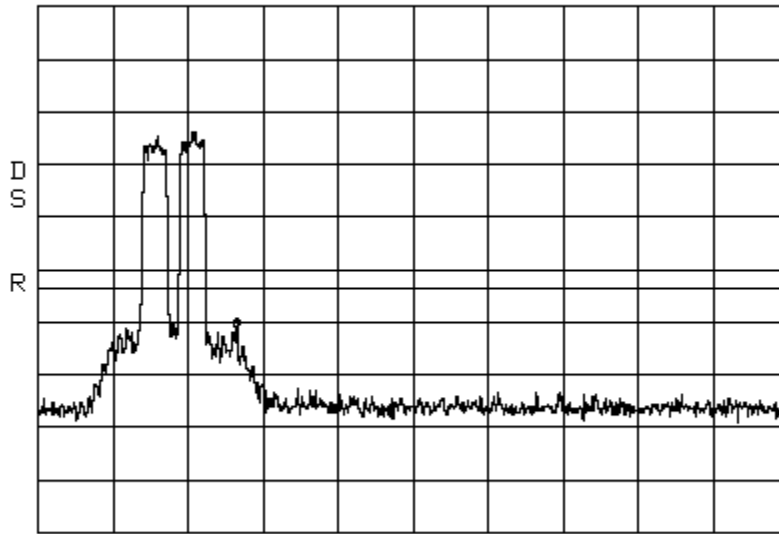

CENTER 1.96250GHz SPAN 90.00MHz
*RBW 100kHz *VBW 100kHz SWP 50ms

Intermodulation LTE 3 MHz Channel Bandwidth_Low Spectrum PCS
 Start: 1924 MHz Stop: 1929 MHz RBW/VBW: 1 MHz



* RBW: 1 MHz * Marker 2 [T1]
 * VBW: 1 MHz * -14.23 dBm
 Ref 10 dBm Att 9 dB SWT 2.0 ms 1.929000000 GHz

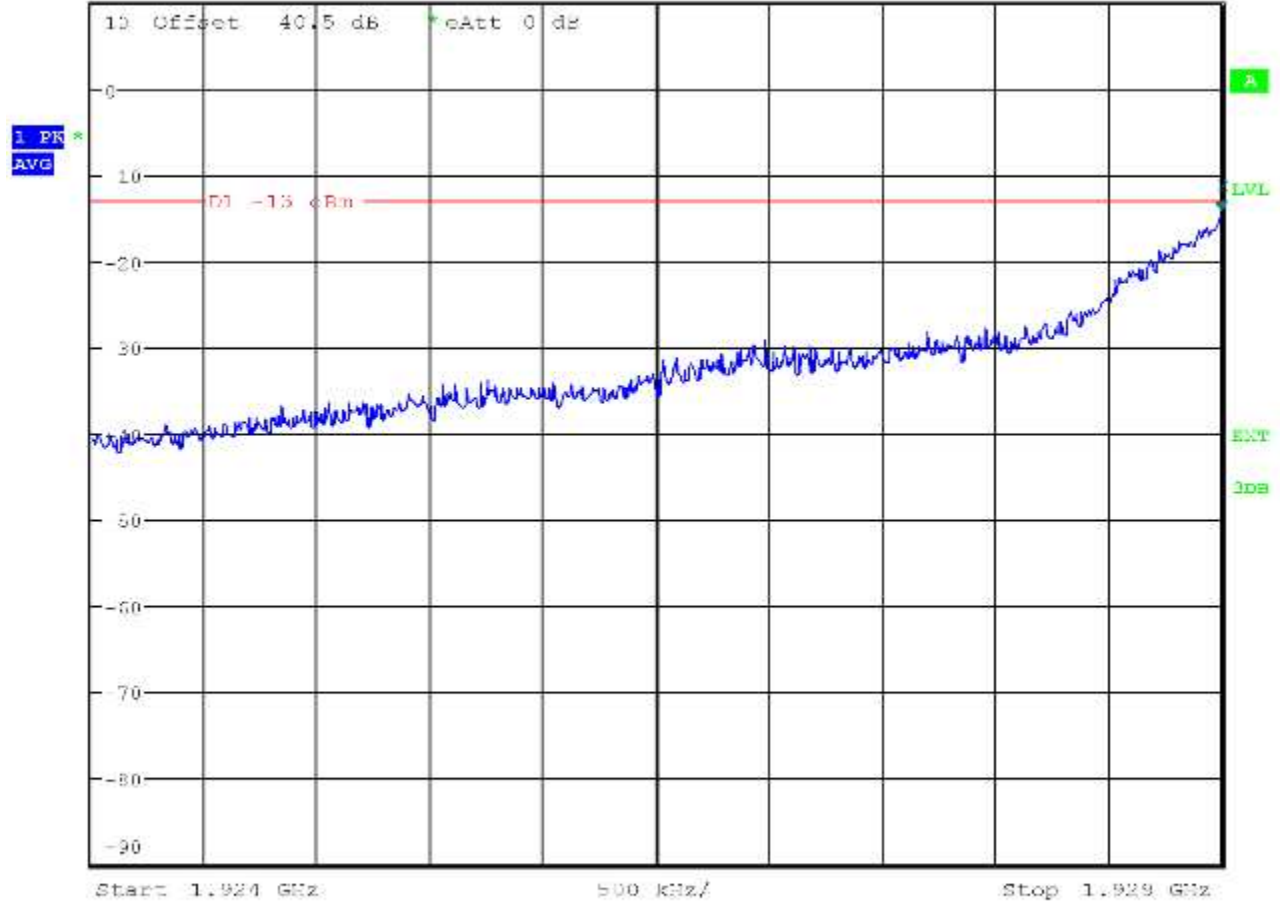

Date: 10.JUL.2012 10:16:42

Intermodulation LTE 3MHz Channel Bandwidth _LowSpectrum PCS
Span: 30 MHz to 1 GHz RBW/VBW: 300 kHz

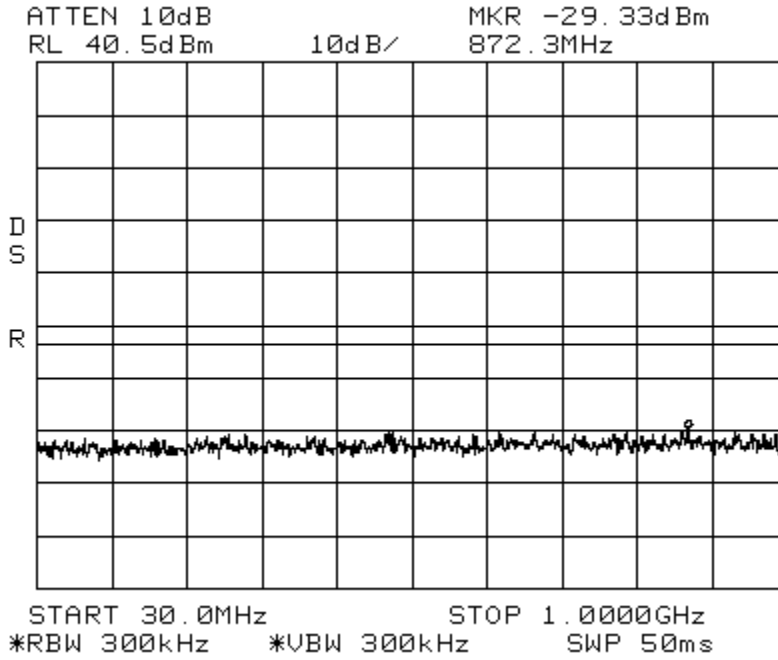

Intermodulation LTE 3 MHz Channel Bandwidth _Low Spectrum PCS
Span: 1 GHz to 20 GHz RBW/VBW: 1 MHz

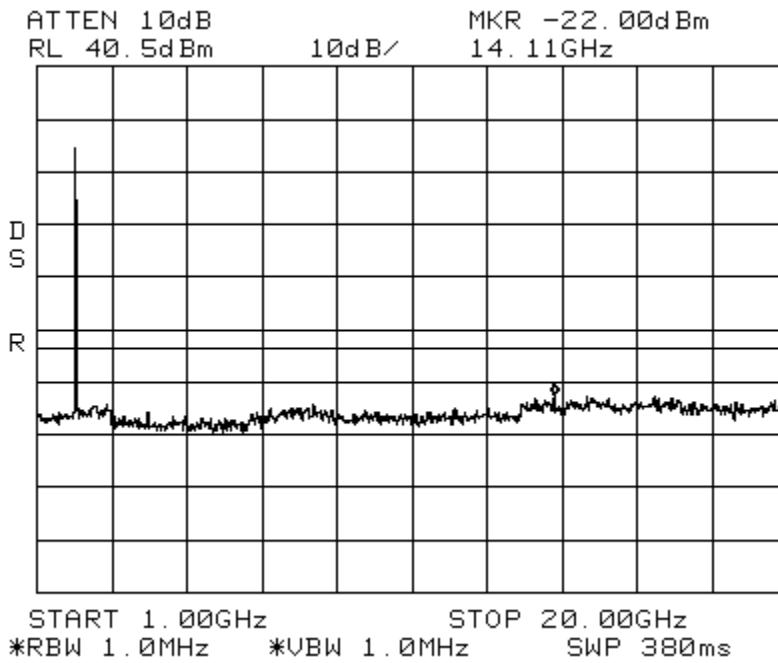

Intermodulation LTE 3 MHz Channel Bandwidth _High Spectrum PCS
Center: 1962.5 MHz Span: 90 MHz RBW/VBW: 100 kHz

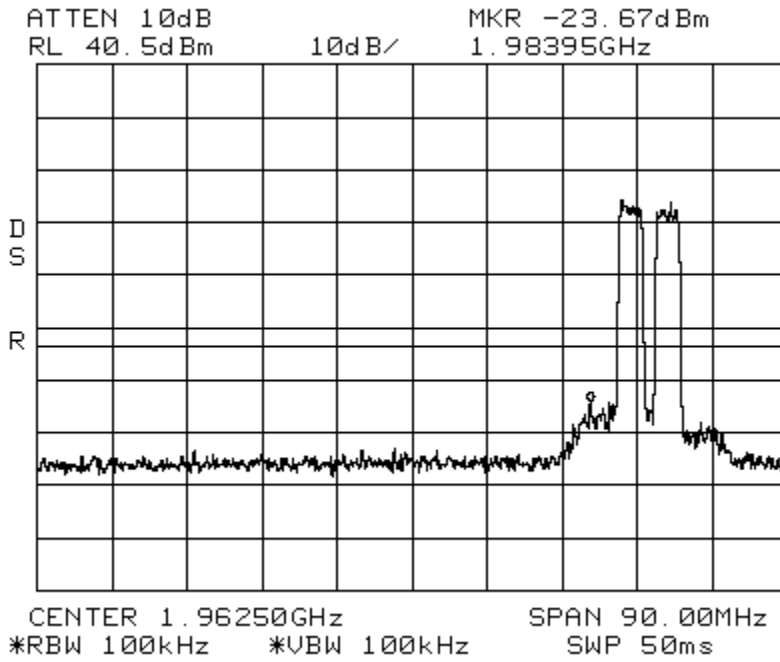

Intermodulation LTE 3 MHz Channel Bandwidth _High Spectrum PCS
Span: 30 MHz to 1 GHz RBW/VBW: 300 kHz

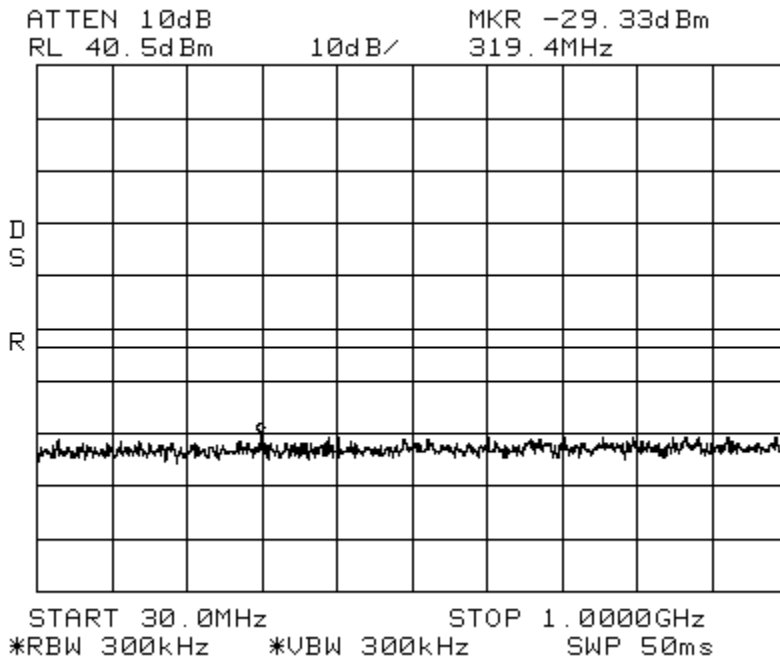

Intermodulation LTE 3 MHz Channel Bandwidth _High Spectrum PCS
Span: 1 GHz to 20 GHz RBW/VBW: 1 MHz

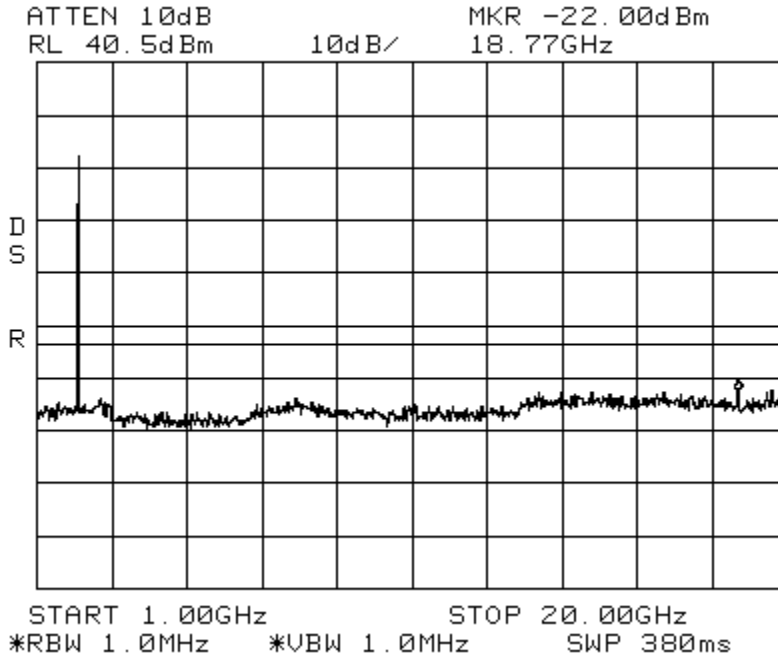

Intermodulation LTE 3 MHz Channel Bandwidth _Apart Spectrum PCS
Center: 1962.5 MHz Span: 175 MHz RBW/VBW: 100 kHz

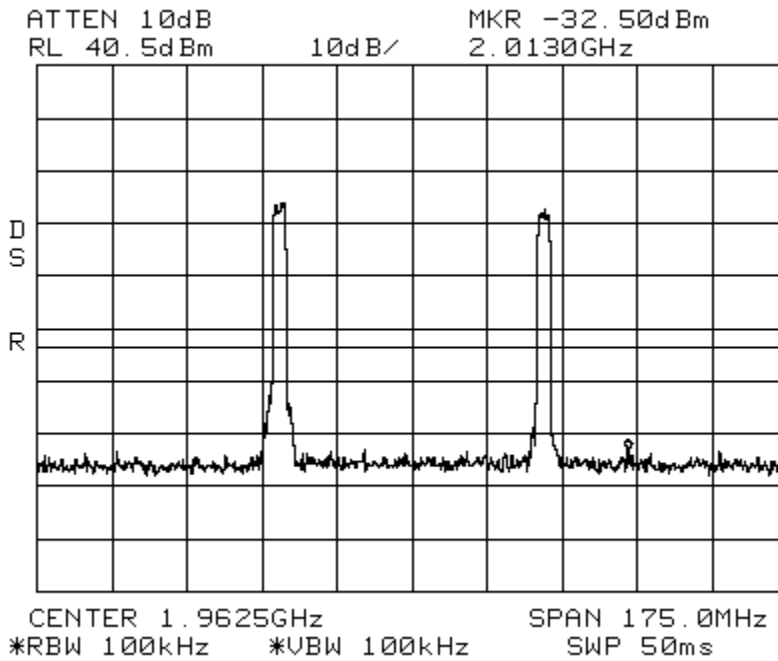

Intermodulation LTE 3 MHz Channel Bandwidth_Apart Spectrum PCS
Span: 30 MHz to 1 GHz RBW/VBW: 300 kHz

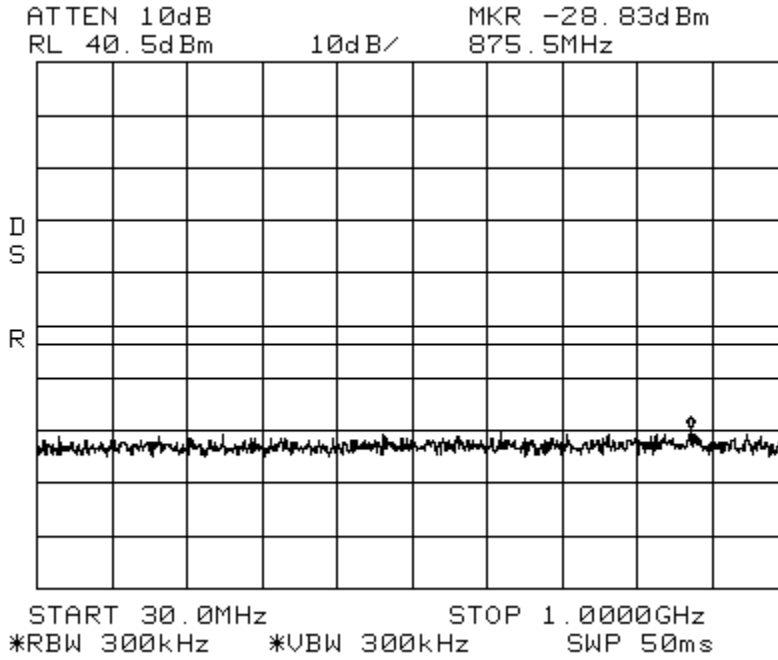

Intermodulation LTE 3 MHz Channel Bandwidth_Apart Spectrum PCS
Span: 1 GHz to 20 GHz RBW/VBW: 1 MHz

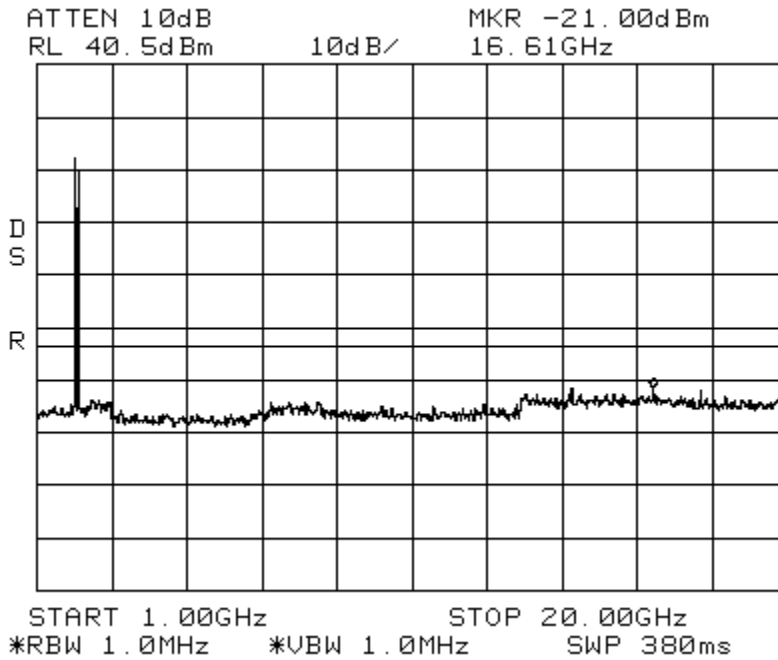

Intermodulation LTE 5 MHz Channel Bandwidth_ **Low** Spectrum PCS
Center: 1962.5 MHz Span: 90 MHz RBW/VBW: 100 kHz

ATTEN 10dB MKR -22.67dBm
RL 40.5dBm 10dB/ 1.92860GHz

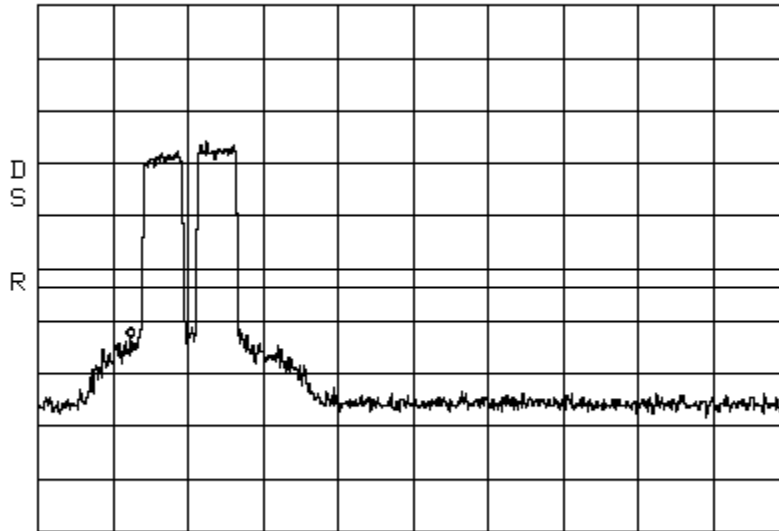

CENTER 1.96250GHz SPAN 90.00MHz
*RBW 100kHz *VBW 100kHz SWP 50ms

Intermodulation LTE 5 MHz Channel Bandwidth_LowSpectrum PCS
 Start: 1924 MHz Stop: 1929 MHz RBW/VBW: 1 MHz



* RBW: 1 MHz Marker 2 [T1]
 * VBW: 1 MHz -14.21 dBm

Ref 10 dBm Att 9 dB SWT 2.8 ms 1.929000000 GHz

1 PK*
 AVG

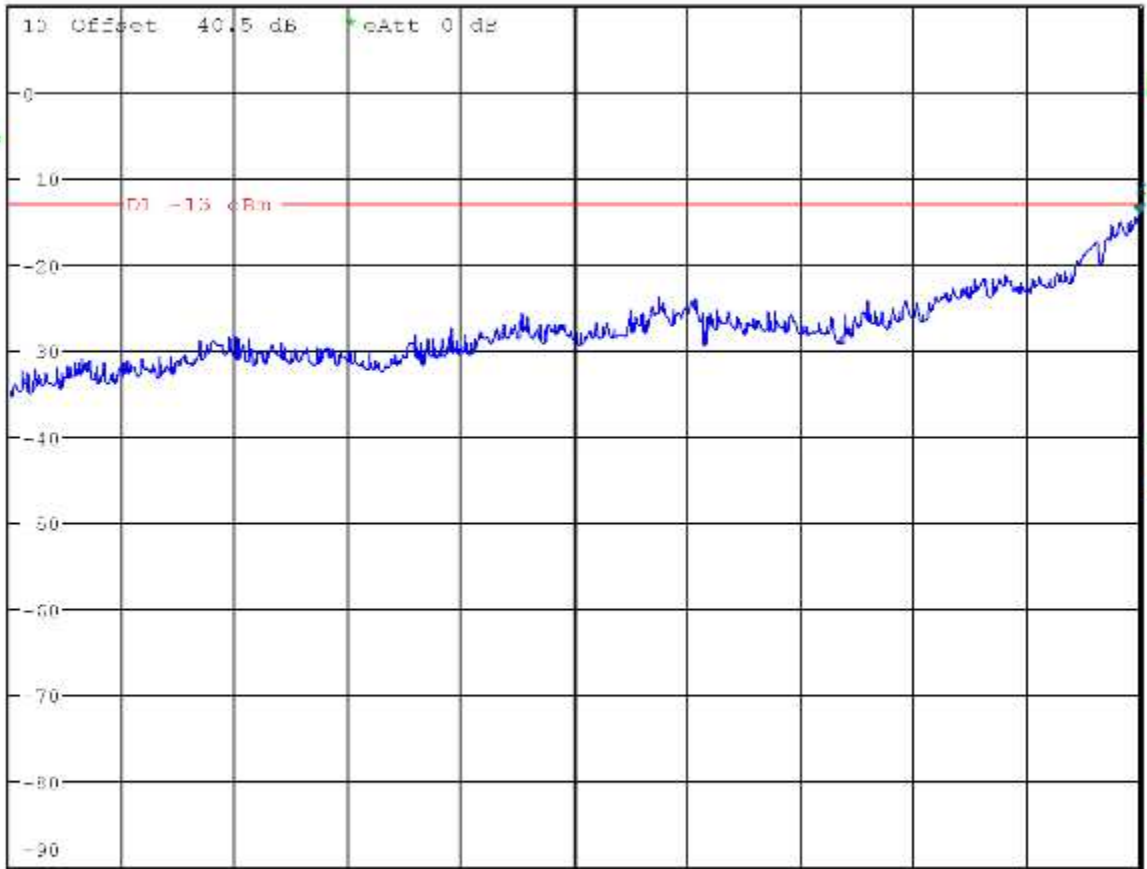

Start 1.924 GHz 500 kHz/ Stop 1.929 GHz

Date: 10.JUL.2012 10:19:48

Intermodulation LTE 5 MHz Channel Bandwidth _Low Spectrum PCS
Span: 30 MHz to 1 GHz RBW/VBW: 300 kHz

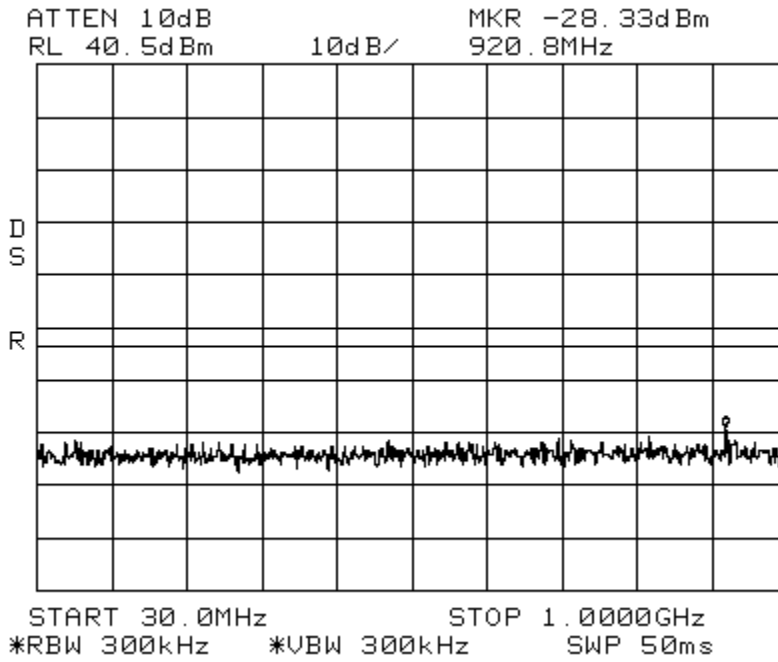

Intermodulation LTE 5 MHz Channel Bandwidth _Low Spectrum PCS
Span: 1 GHz to 20 GHz RBW/VBW: 1 MHz

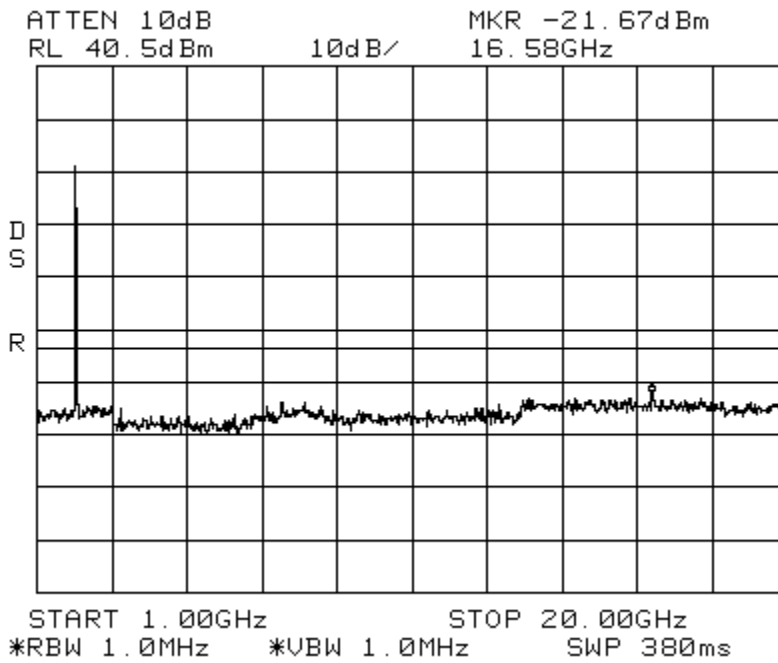

Intermodulation LTE 5 MHz Channel Bandwidth _High Spectrum PCS
Center: 1962.5 MHz Span: 90 MHz RBW/VBW: 100 kHz
ATTEN 10dB MKR -26.33dBm
RL 40.5dBm 10dB/ 1.97510GHz

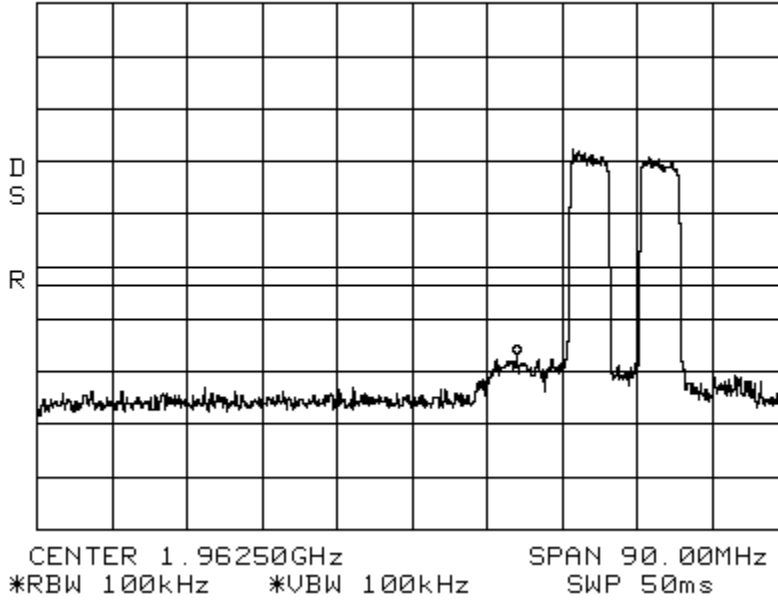

Intermodulation LTE 5 MHz Channel Bandwidth _High Spectrum PCS
Span: 30 MHz to 1 GHz RBW/VBW: 300 kHz

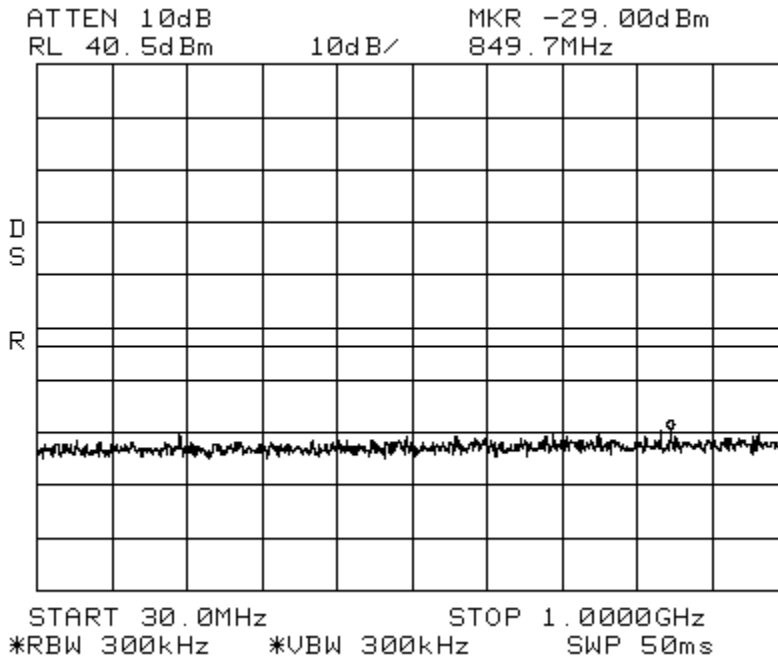

Intermodulation LTE 5 MHz Channel Bandwidth _High Spectrum PCS
Span: 1 GHz to 20 GHz RBW/VBW: 1 MHz

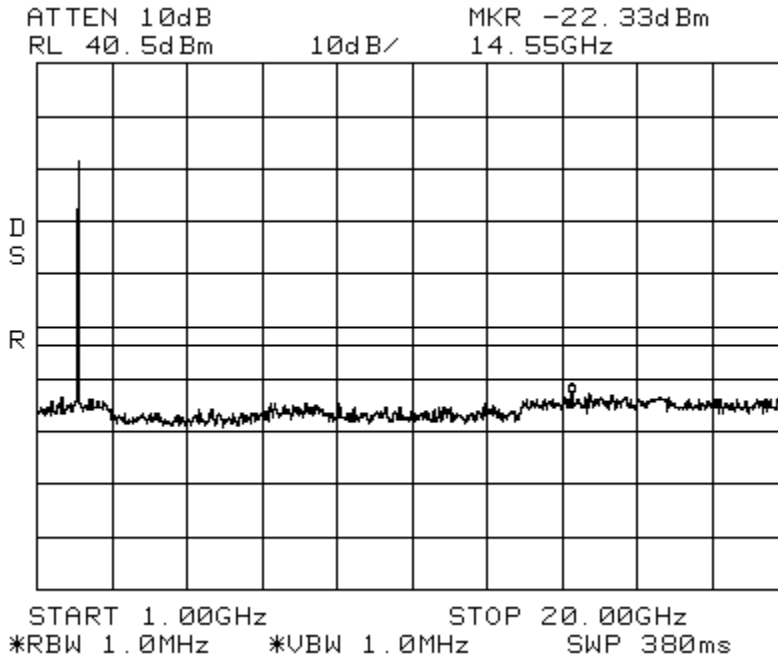

Intermodulation LTE 5 MHz Channel Bandwidth _Apart Spectrum PCS
Center: 1962.5 MHz Span: 175 MHz RBW/VBW: 100 kHz

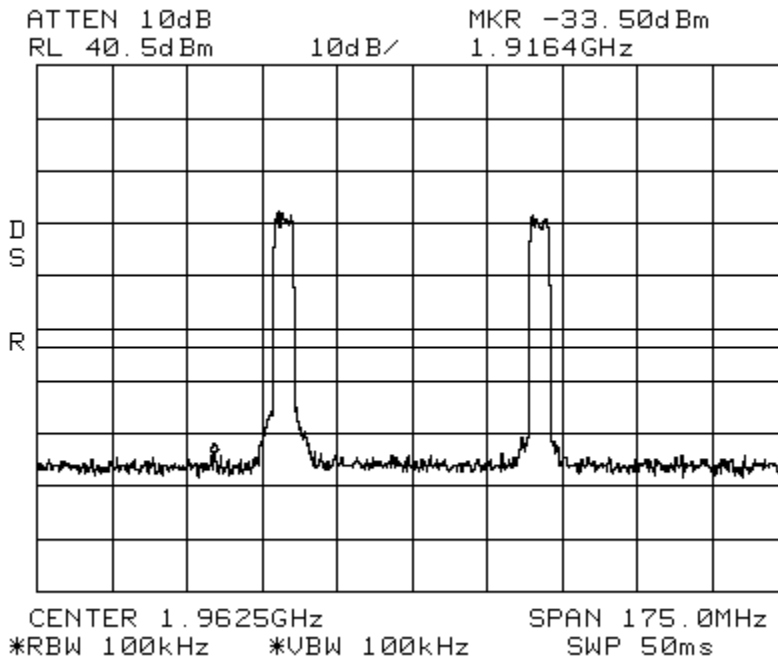

Intermodulation LTE 5 MHz Channel Bandwidth _Apart Spectrum PCS
Span: 30 MHz to 1 GHz RBW/VBW: 300 kHz

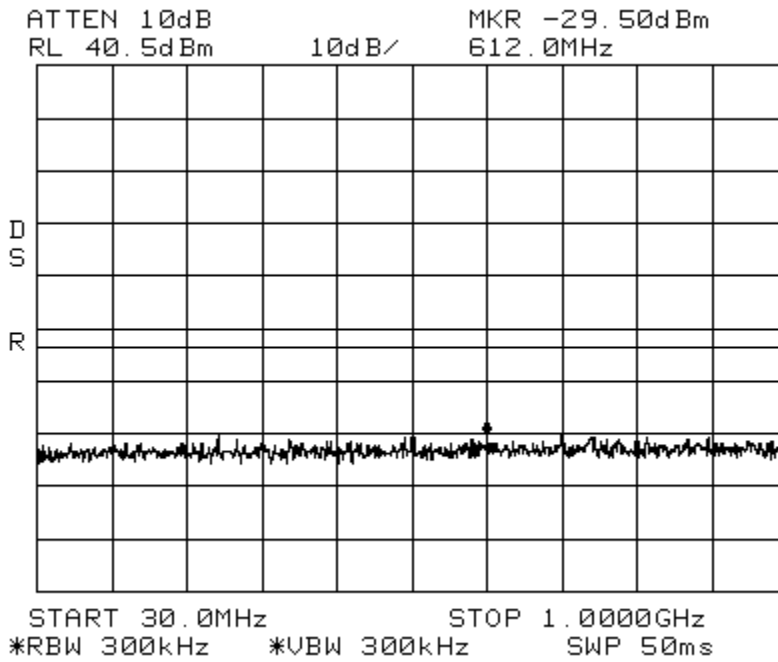

Intermodulation LTE 5 MHz Channel Bandwidth _Apart Spectrum PCS
Span: 1 GHz to 20 GHz RBW/VBW: 1 MHz

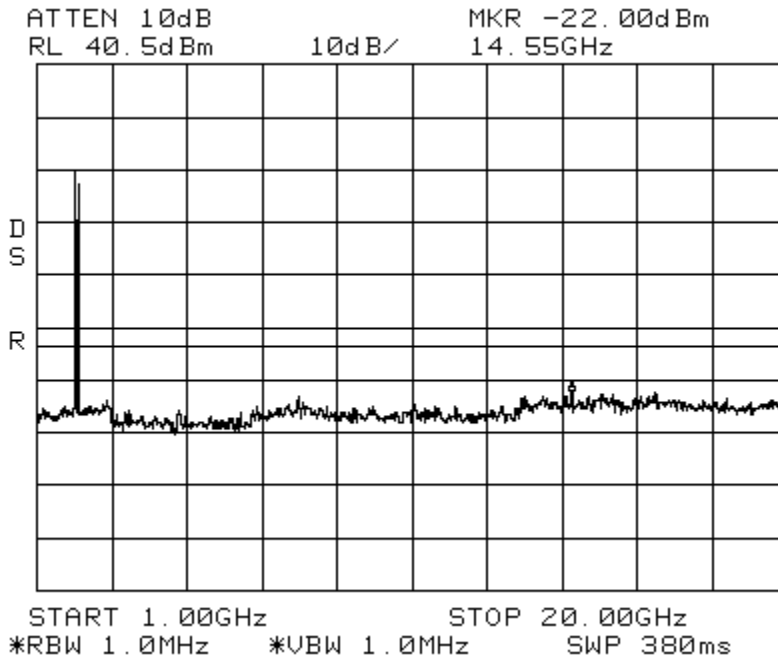

Intermodulation LTE 10 MHz Channel Bandwidth_Low Spectrum PCS
Center: 1962.5 MHz Span: 90 MHz RBW/VBW: 100 kHz
ATTEN 10dB MKR -22.83dBm
RL 40.5dBm 10dB/ 1.95530GHz

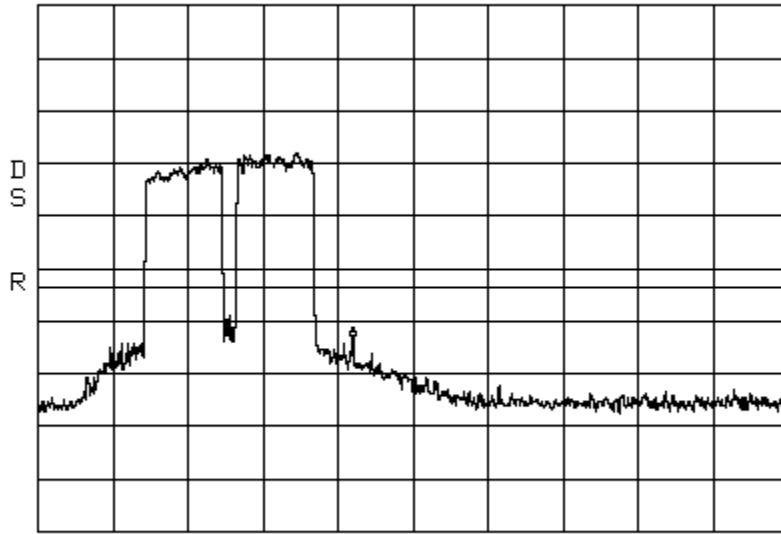

CENTER 1.96250GHz SPAN 90.00MHz
*RBW 100kHz *VBW 100kHz SWP 50ms



RBW: 1 MHz Marker 2 [T1]
VBW: 1 MHz -15.18 dBm
SWT: 2.0 ms 1.929000000 GHz

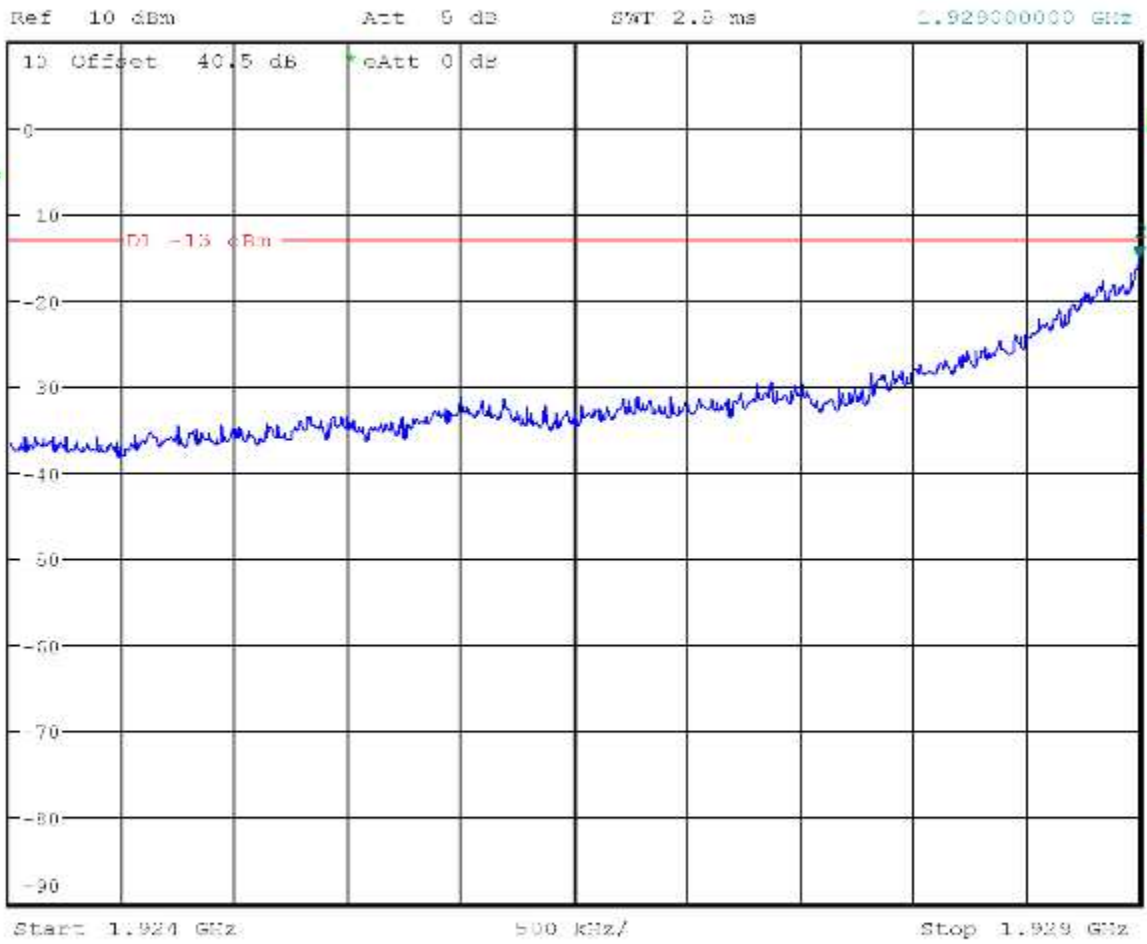

Date: 10.JUL.2012 10:02:59

Intermodulation LTE 10 MHz Channel Bandwidth_Low Spectrum PCS
Span: 30 MHz to 1 GHz RBW/VBW: 300 kHz

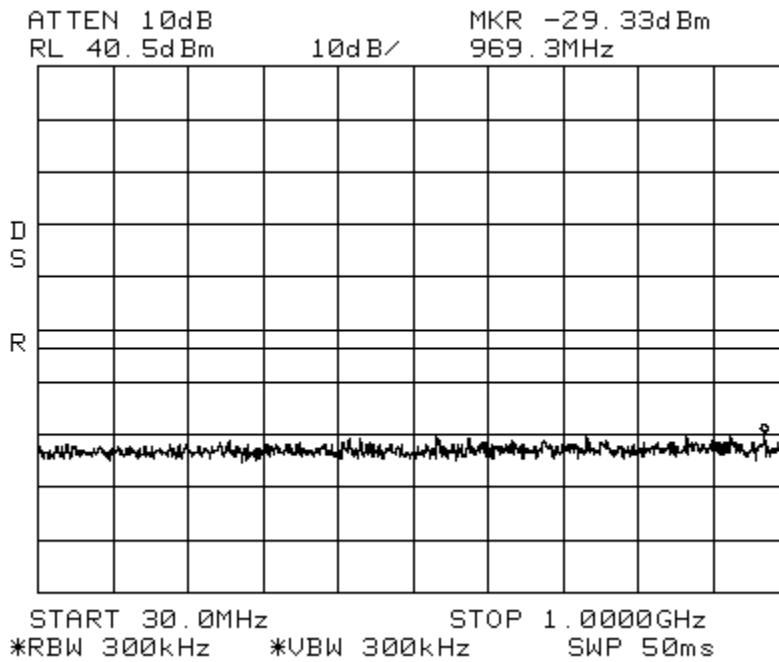

Intermodulation LTE 10 MHz Channel Bandwidth_Low Spectrum PCS
Span: 1 GHz to 20GHz RBW/VBW: 1 MHz

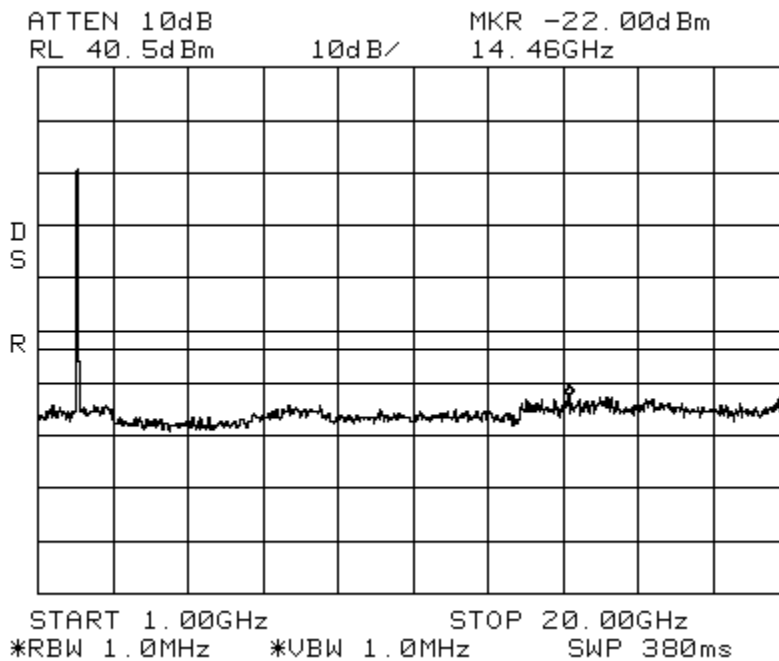

Intermodulation LTE 10 MHz Channel Bandwidth_High Spectrum PCS
Center: 1962.5 MHz Span: 90 MHz RBW/VBW: 100 kHz

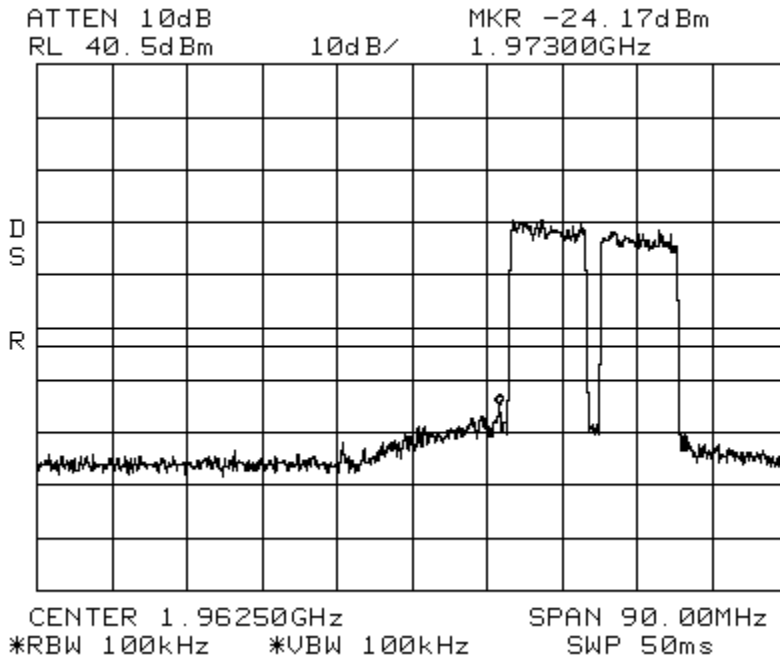

Intermodulation LTE 10 MHz Channel Bandwidth_High Spectrum PCS
Span: 30 MHz to 1 GHz RBW/VBW: 300 kHz

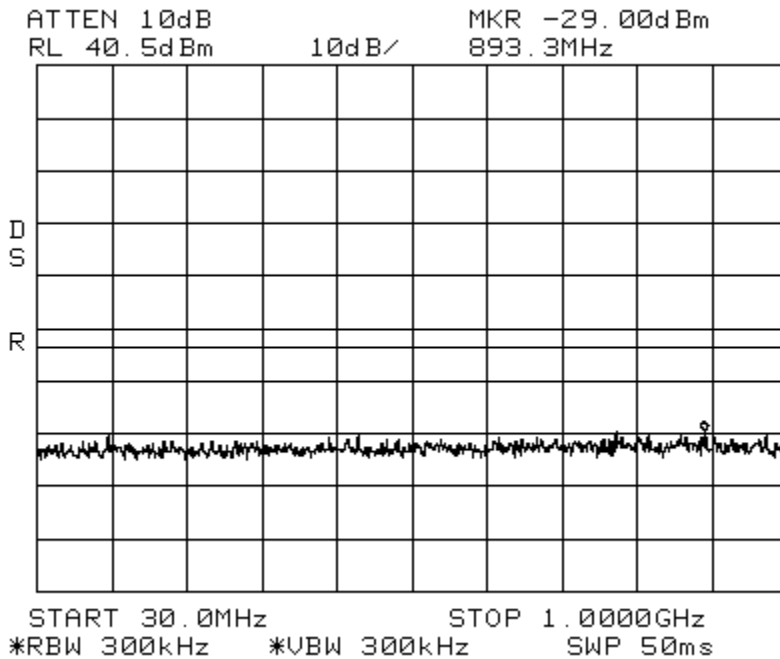

Intermodulation LTE 10 MHz Channel Bandwidth_High Spectrum PCS
Span: 1 GHz to 20 GHz RBW/VBW: 1 MHz

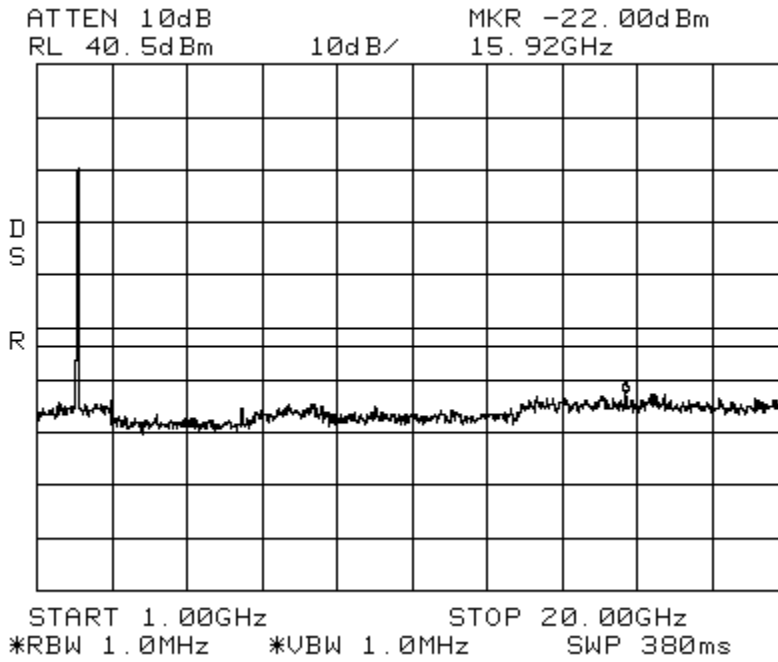

Intermodulation LTE 10 MHz Channel Bandwidth_Apart Spectrum PCS
Center: 1962.5 MHz Span: 175 MHz RBW/VBW: 100 kHz

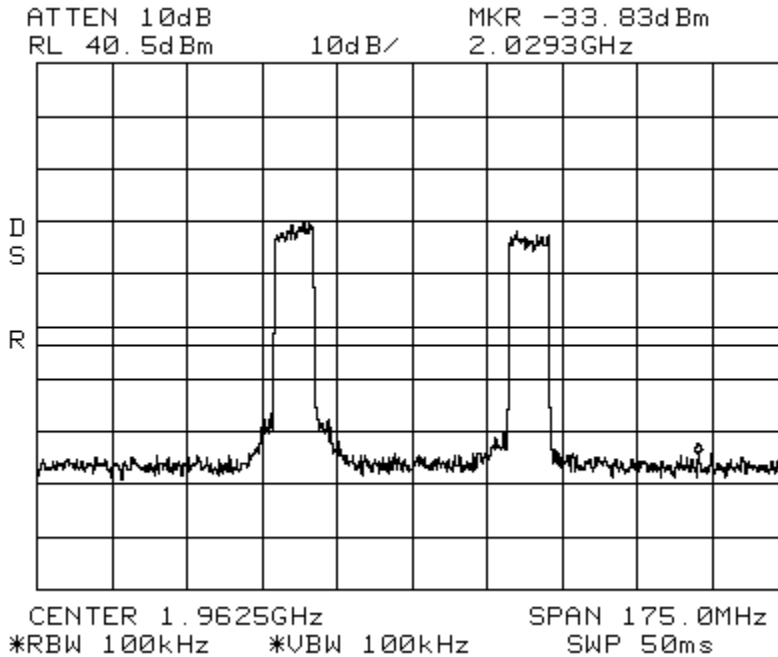

Intermodulation LTE 10 MHz Channel Bandwidth _Apart Spectrum PCS
Span: 30 MHz to 1 GHz RBW/VBW: 300 kHz

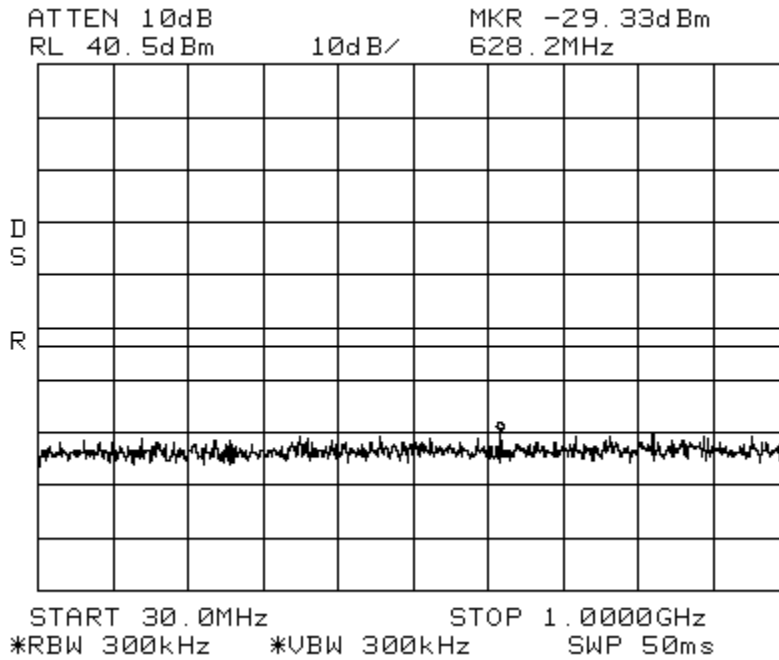

Intermodulation LTE 10 MHz Channel Bandwidth _Apart Spectrum PCS
Span: 1 GHz to 20 GHz RBW/VBW: 1 MHz

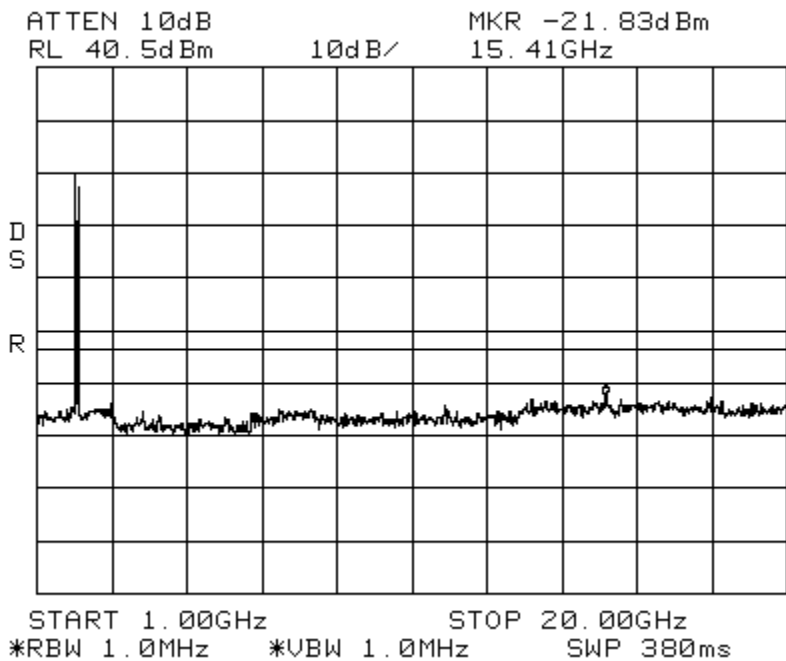

Intermodulation LTE 15 MHz Channel Bandwidth_Low Spectrum PCS
Center: 1962.5 MHz Span: 90 MHz RBW/VBW: 100 kHz

ATTEN 10dB MKR -24.17dBm
RL 40.5dBm 10dB/ 1.96535GHz

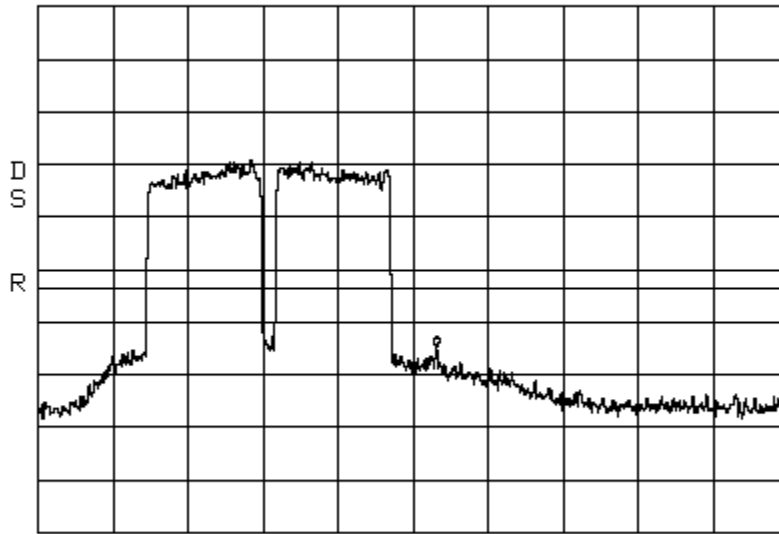

CENTER 1.96250GHz SPAN 90.00MHz
*RBW 100kHz *VBW 100kHz SWP 50ms

Intermodulation LTE 15 MHz Channel Bandwidth _Low Spectrum PCS
 Start: 1924 MHz Stop: 1929 MHz RBW/VBW: 1 MHz



* RBW: 1 MHz * Marker 2 [T1] -15.70 dBm
 * VBW: 1 MHz
 Ref 10 dBm Att 9 dB SWT 2.0 ms 1.92900000 GHz

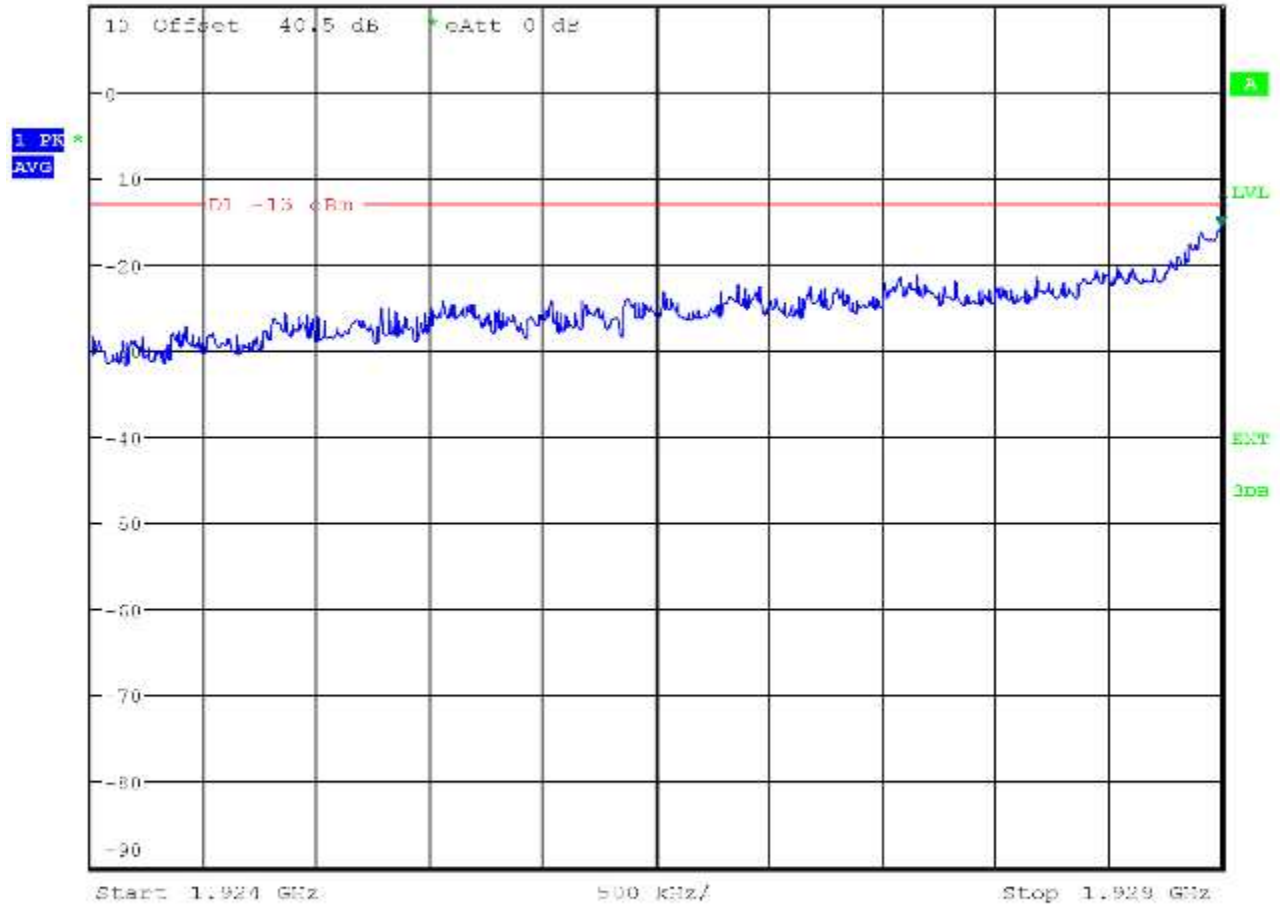

Date: 10.JUL.2012 10:05:46

Intermodulation LTE 15 MHz Channel Bandwidth_Low Spectrum PCS
Span: 30 MHz to 1 GHz RBW/VBW: 300 kHz

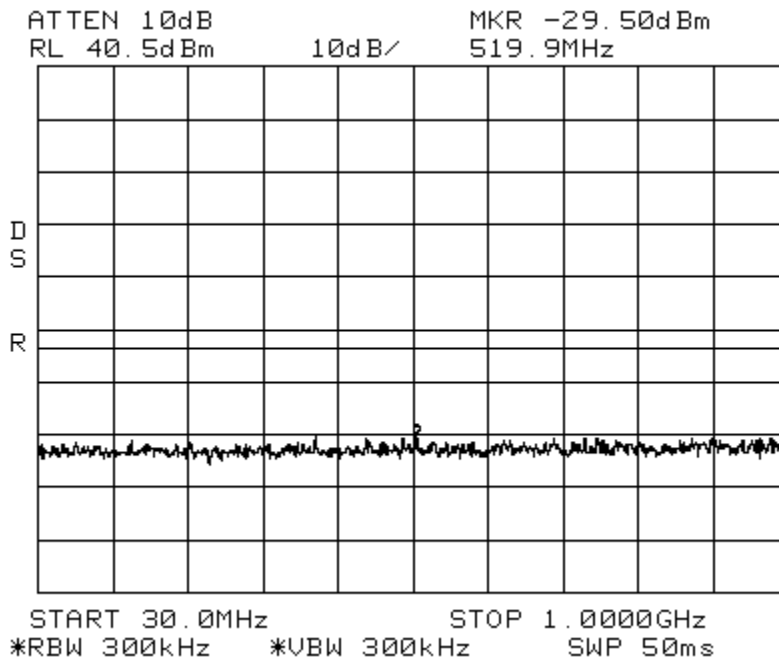

Intermodulation LTE 15 MHz Channel Bandwidth_Low Spectrum PCS
Span: 1 GHz to 20 GHz RBW/VBW: 1 MHz

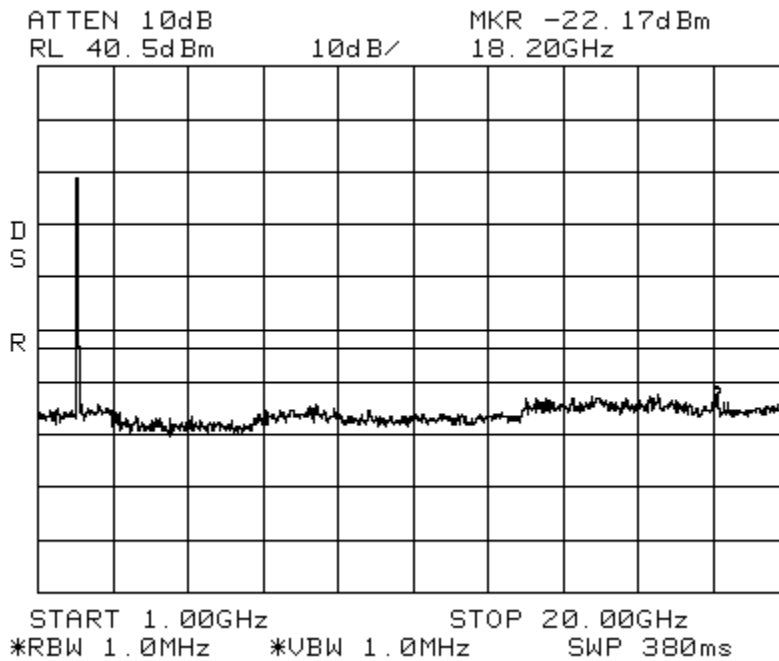

Intermodulation LTE 15 MHz Channel Bandwidth_High Spectrum PCS
Center: 1962.5 MHz Span: 90 MHz RBW/VBW: 100 kHz
ATTEN 10dB MKR -25.83dBm
RL 40.5dBm 10dB/ 1.96145GHz

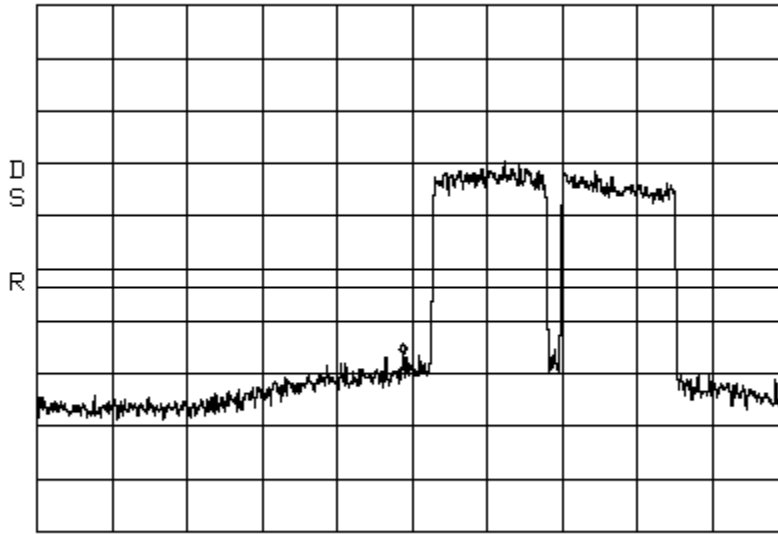

CENTER 1.96250GHz SPAN 90.00MHz
*RBW 100kHz *VBW 100kHz SWP 50ms

Intermodulation LTE 15 MHz Channel Bandwidth_High Spectrum PCS
Span: 30 MHz to 1 GHz RBW/VBW: 300 kHz

ATTEN 10dB MKR -29.67dBm
RL 40.5dBm 10dB/ 141.6MHz

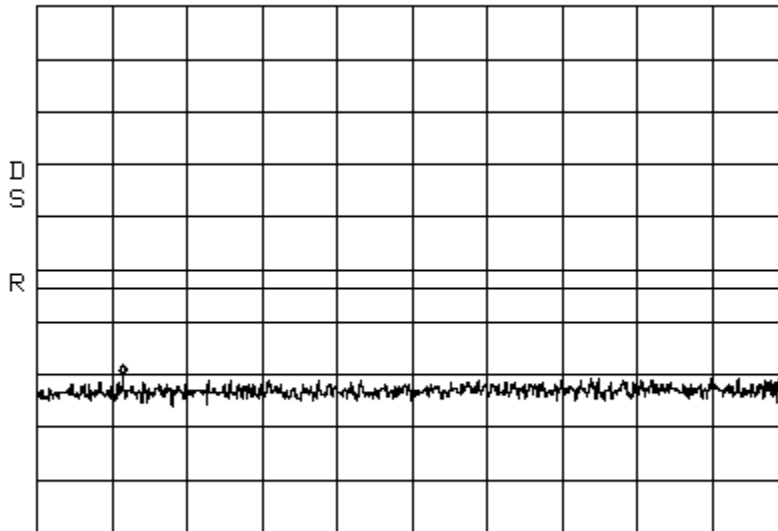

START 30.0MHz STOP 1.0000GHz
*RBW 300kHz *VBW 300kHz SWP 50ms

Intermodulation LTE 15 MHz Channel Bandwidth_High Spectrum PCS
Span: 1 GHz to 20 GHz RBW/VBW: 1 MHz

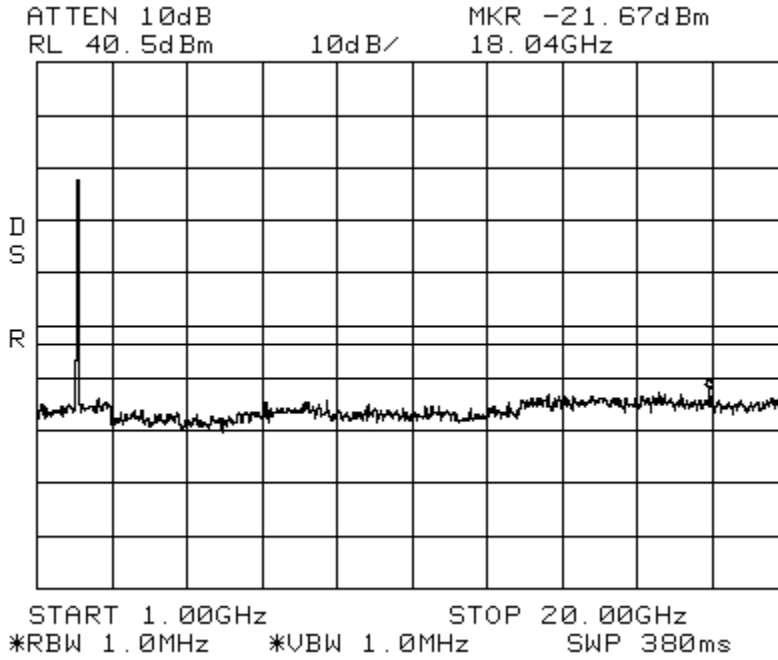

Intermodulation LTE 15 MHz Channel Bandwidth_Apart Spectrum PCS
Center: 1962.5 MHz Span: 90 MHz RBW/VBW: 100 kHz

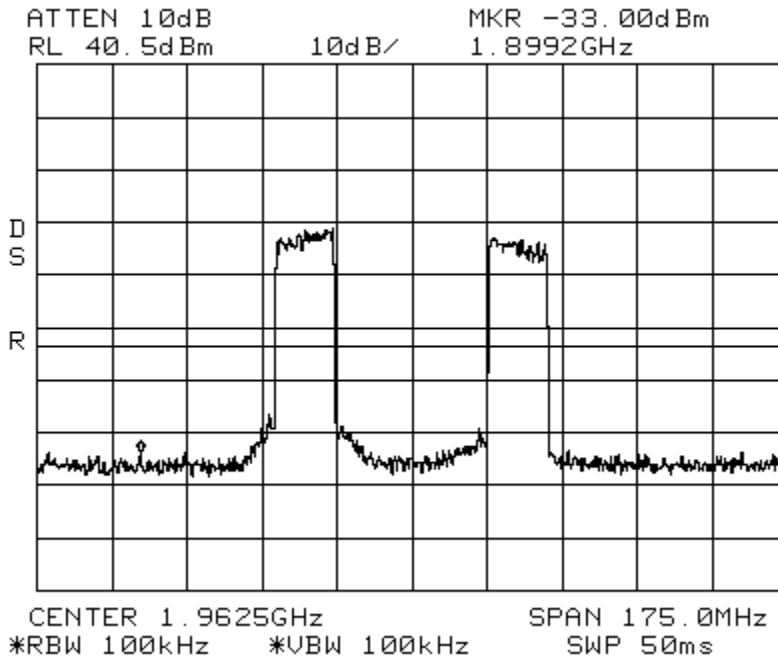

Intermodulation LTE 15 MHz Channel Bandwidth _Apart Spectrum PCS
Span: 30 MHz to 1 GHz RBW/VBW: 300 kHz

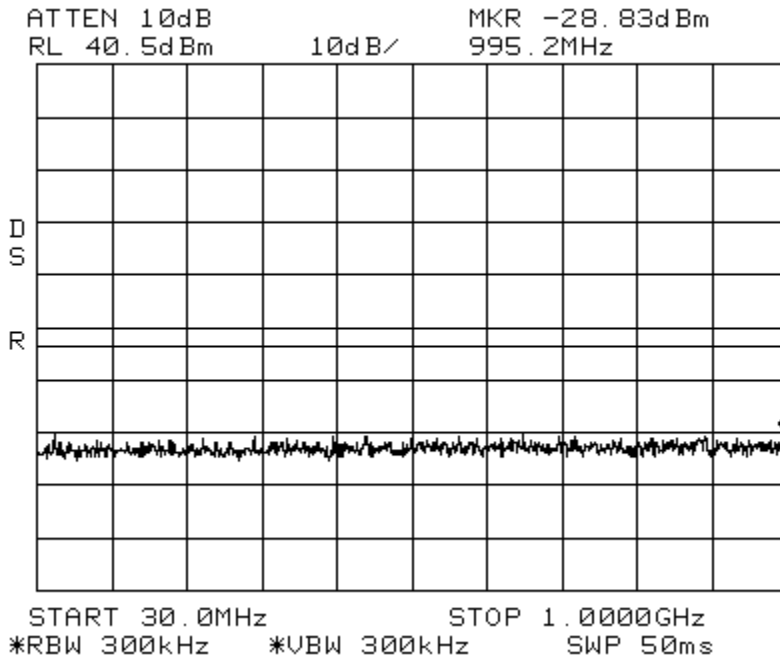

Intermodulation LTE 15 MHz Channel Bandwidth _Apart Spectrum PCS
Span: 1 GHz to 20 GHz RBW/VBW: 1 MHz

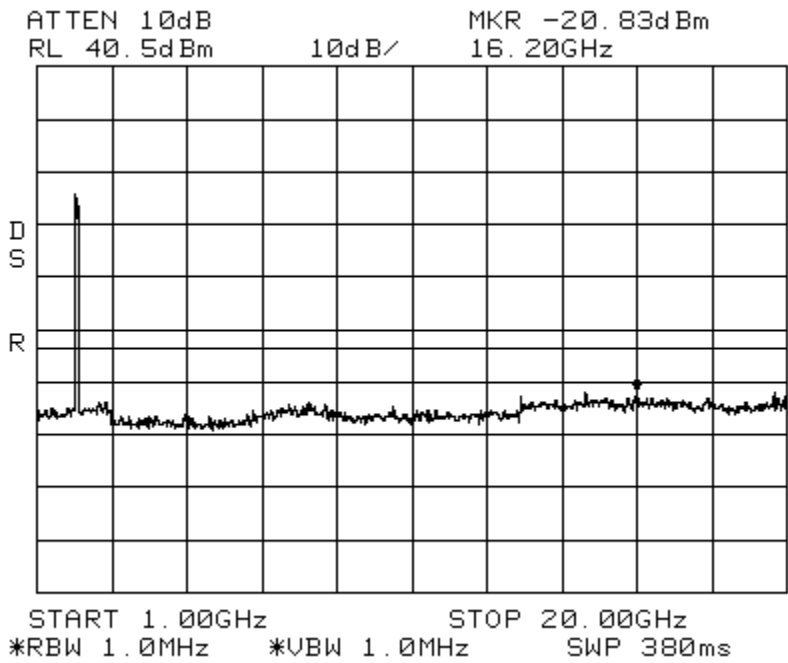

Intermodulation LTE 20 MHz Channel Bandwidth_Low Spectrum PCS
Center: 1962.5 MHz Span: 90 MHz RBW/VBW: 100 kHz

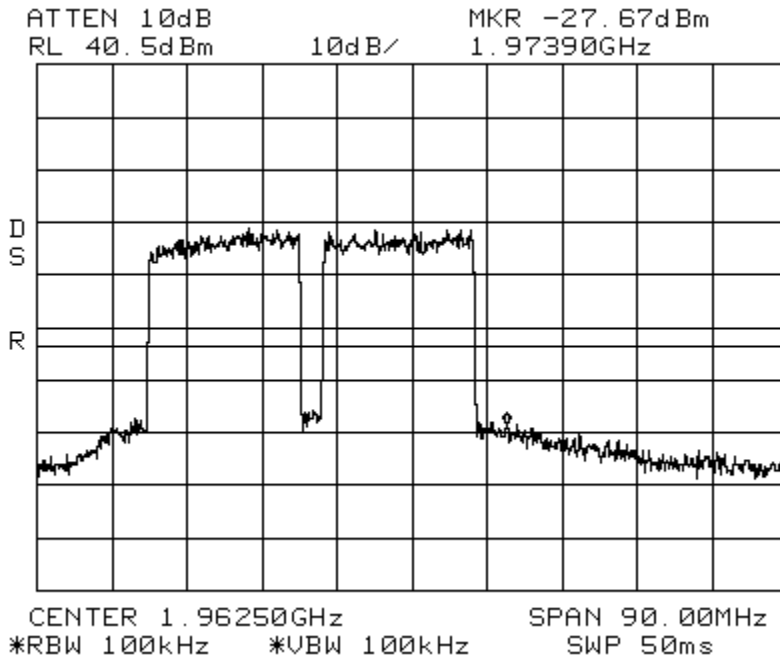

Intermodulation LTE 20 MHz Channel Bandwidth_Low Spectrum PCS
Span: 30 MHz to 1 GHz RBW/VBW: 300 kHz

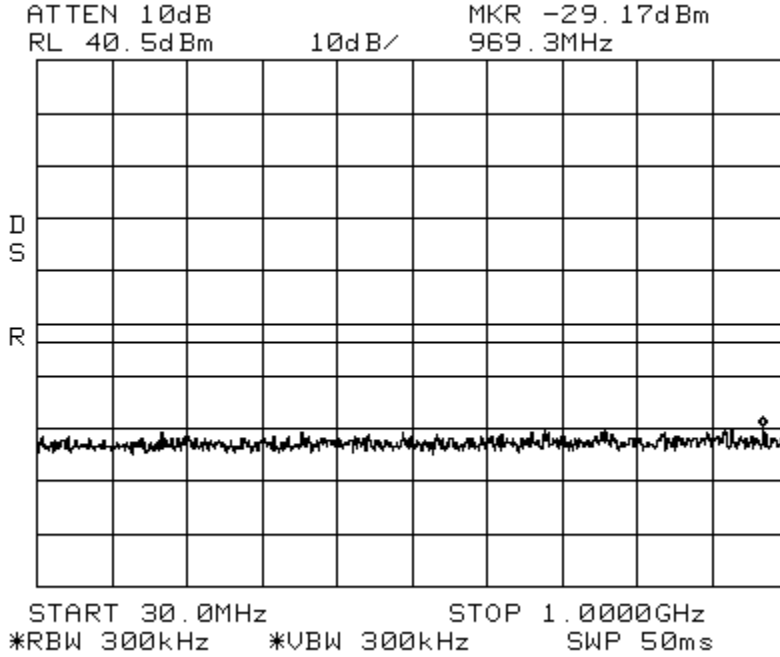

Intermodulation LTE 20 MHz Channel Bandwidth _Low Spectrum PCS
Span: 1 GHz to 20GHz RBW/VBW: 1 MHz

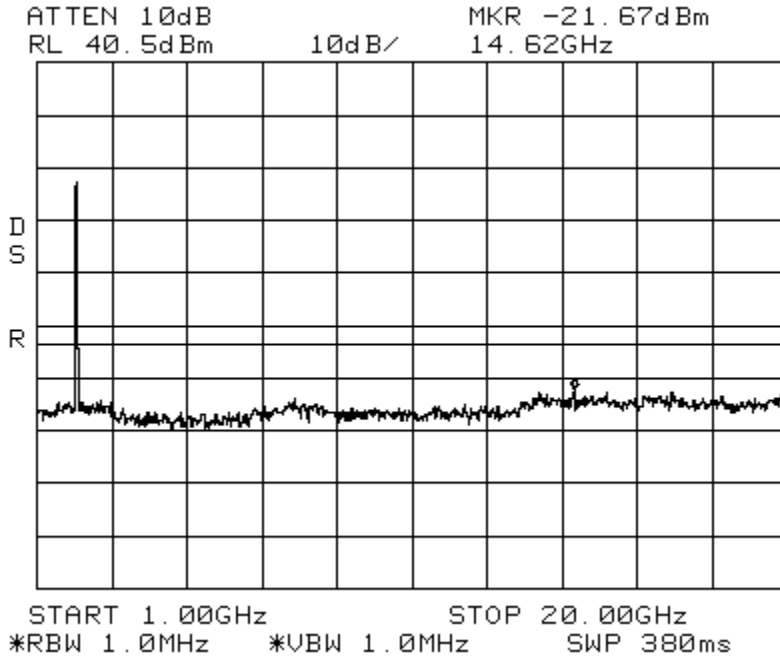

Intermodulation LTE 20 MHz Channel Bandwidth _High Spectrum PCS
Center: 1962.5 MHz Span: 90 MHz RBW/VBW: 100 kHz

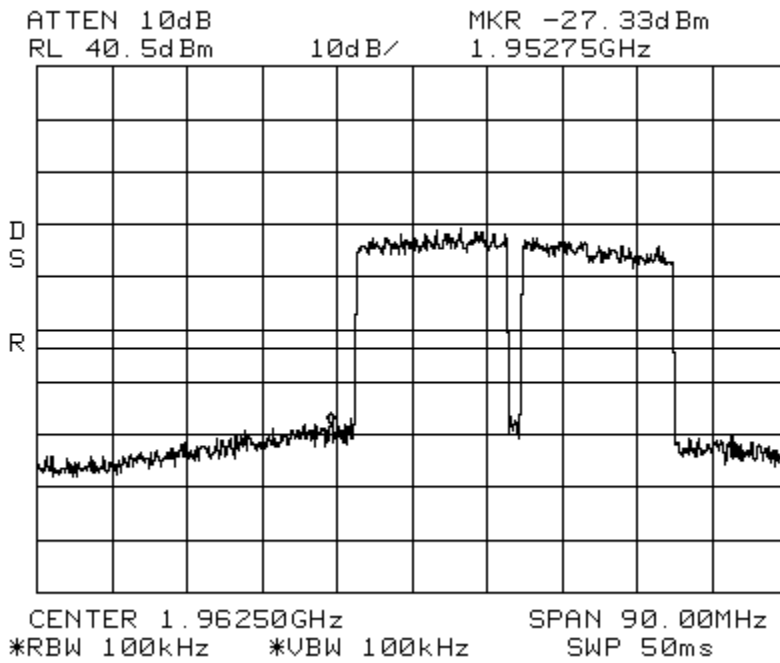

Intermodulation LTE 20 MHz Channel Bandwidth_High Spectrum PCS
Span: 30 MHz to 1 GHz RBW/VBW: 300 kHz

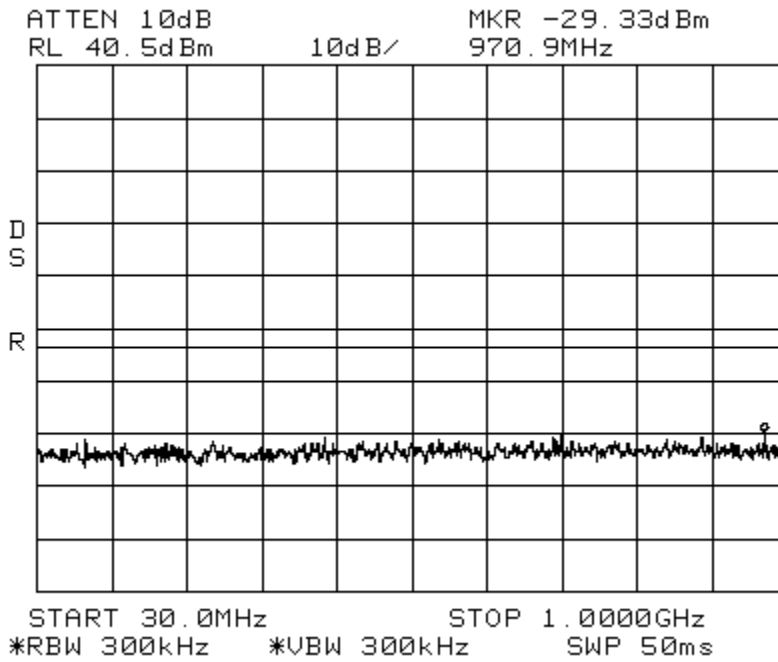

Intermodulation LTE 20 MHz Channel Bandwidth_High Spectrum PCS
Span: 1 GHz to 20 GHz RBW/VBW: 1 MHz

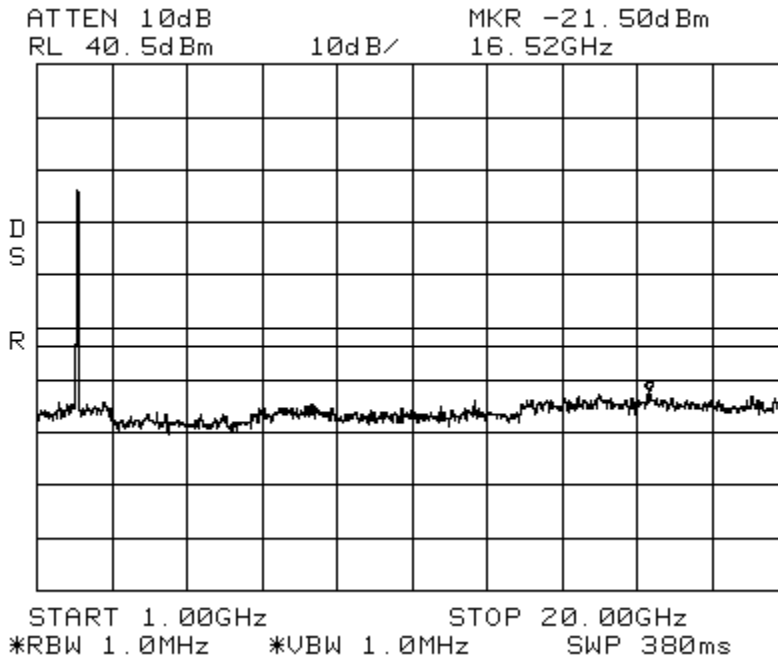

Intermodulation LTE 20 MHz Channel Bandwidth _Apart Spectrum PCS
Center: 1962.5 MHz Span: 175 MHz RBW/VBW: 100 kHz
ATTEN 10dB MKR -33.50dBm
RL 40.5dBm 10dB/ 1.9065GHz

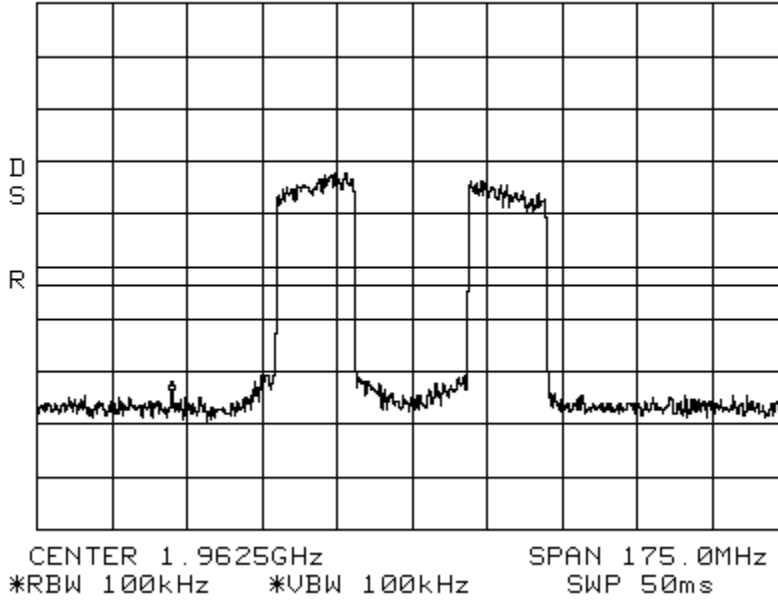

Intermodulation LTE 20 MHz Channel Bandwidth _Apart Spectrum PCS
Span: 30 MHz to 1 GHz RBW/VBW: 300 kHz

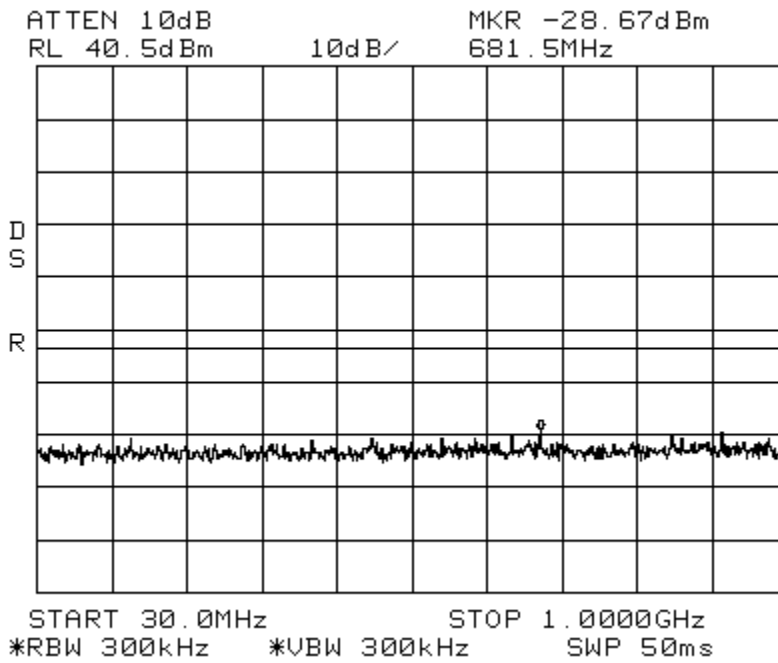

Intermodulation LTE 20 MHz Channel Bandwidth_Apart Spectrum PCS
Span: 1 GHz to 20 GHz RBW/VBW: 1 MHz

ATTEN 10dB MKR -20.17dBm
RL 40.5dBm 10dB/ 16.36GHz

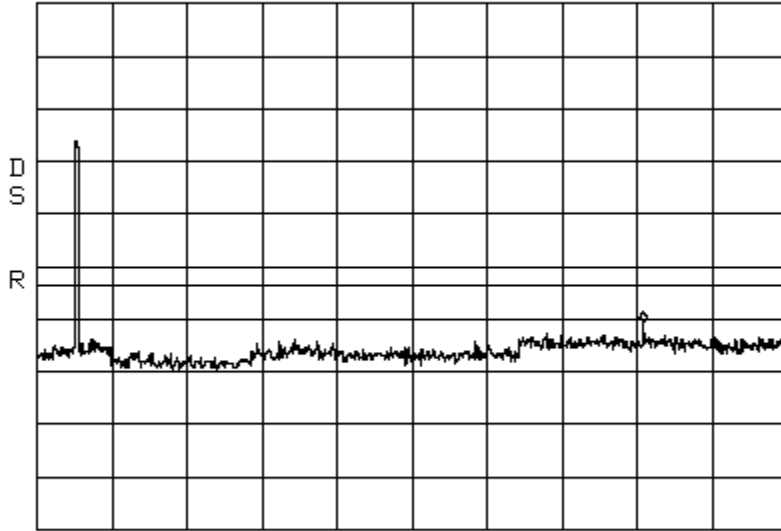

START 1.00GHz STOP 20.00GHz
*RBW 1.0MHz *VBW 1.0MHz SWP 380ms

Intermodulation WCDMA_Low Spectrum PCS Path 1
Center: 1962.5 MHz Span: 90 MHz RBW/VBW: 100 kHz

ATTEN 10dB MKR -21.83dBm
RL 40.5dBm 10dB/ 1.94810GHz

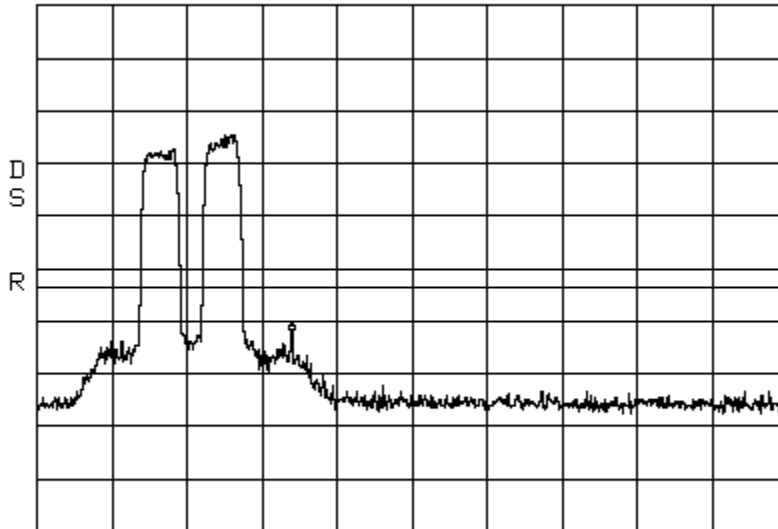

CENTER 1.96250GHz SPAN 90.00MHz
*RBW 100kHz *VBW 100kHz *SWP 180ms

Intermodulation WCDMA_Low Spectrum PCS Path 1
Span: 30 MHz to 1 GHz RBW/VBW: 300 kHz

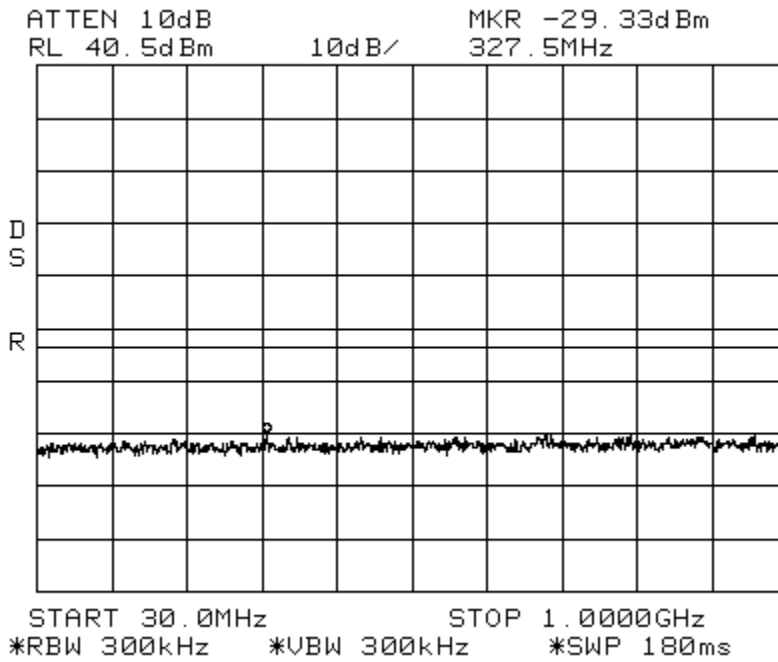

Intermodulation WCDMA_Low Spectrum PCS Path 1
Span: 1 GHz to 20 GHz RBW/VBW: 1 MHz

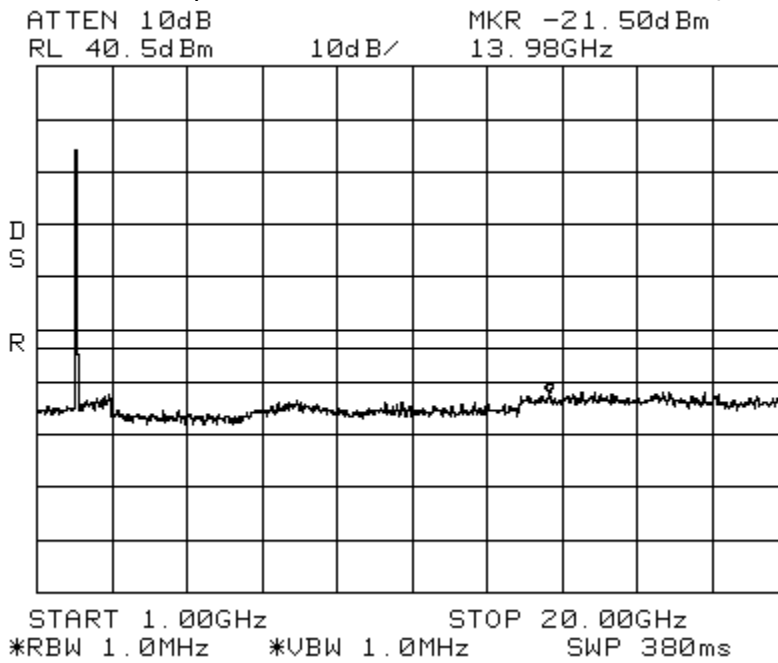

Intermodulation
Center: 1962.5 MHz

WCDMA_High
Span: 90 MHz

Spectrum PCS Path 1
RBW/VBW: 100 kHz

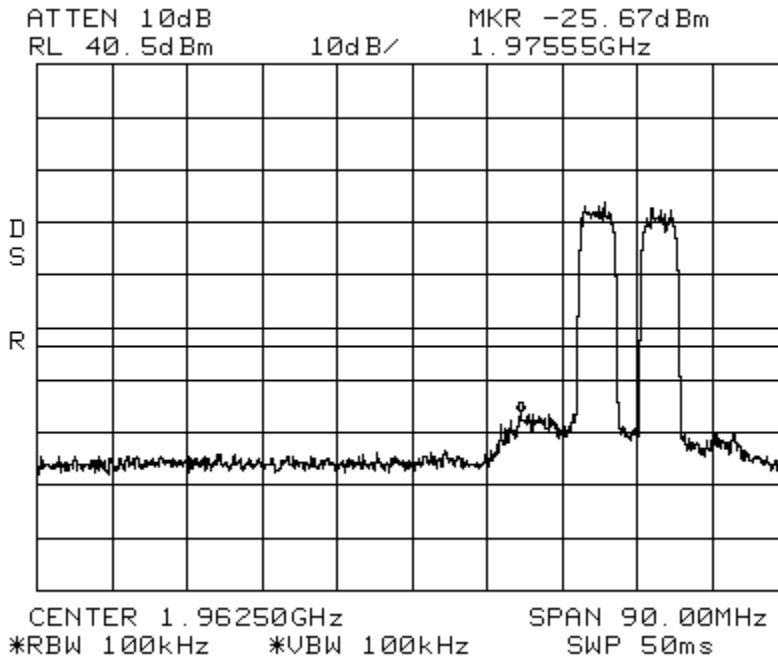

Intermodulation WCDMA_High Spectrum PCS Path 1
Span: 30 MHz to 1 GHz RBW/VBW: 300 kHz

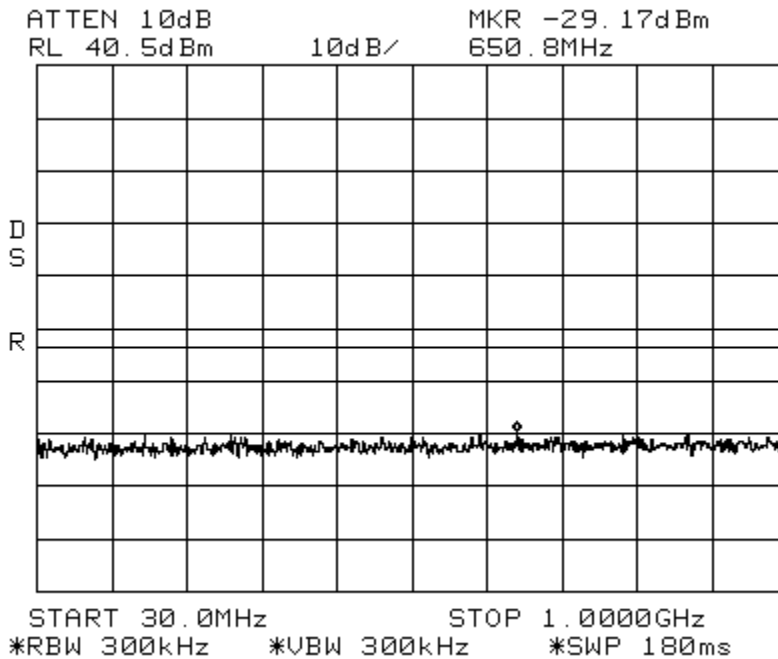

Intermodulation WCDMA_High Spectrum PCS Path 1
Span: 1 GHz to 20 GHz RBW/VBW: 1 MHz

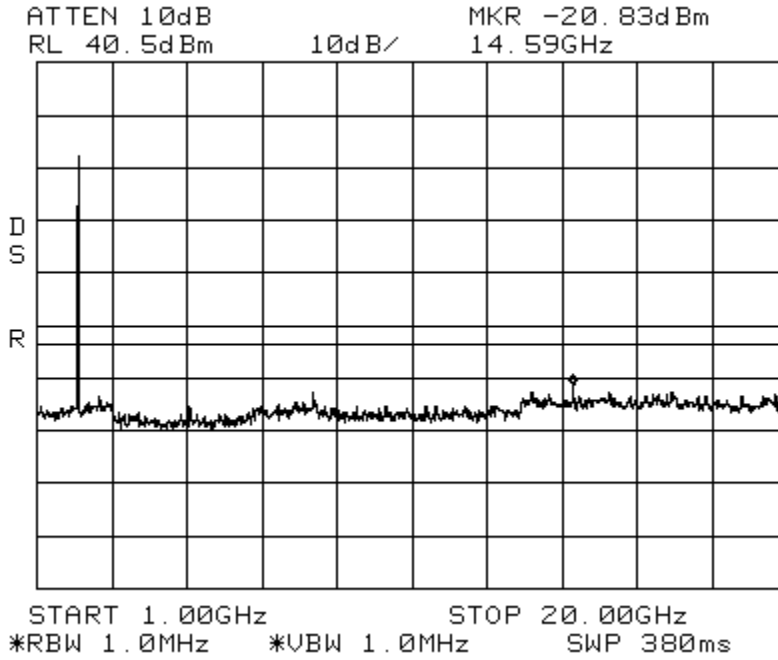

Intermodulation WCDMA_Apart Spectrum PCS Path 1
Center: 1962.5 MHz Span: 175 MHz RBW/VBW: 100 kHz

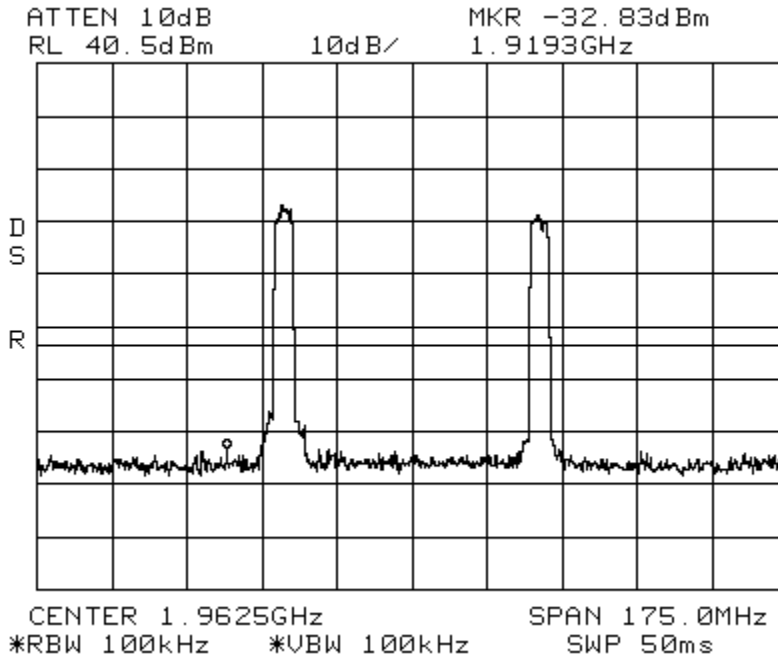

Intermodulation

WCDMA_Apart

Spectrum PCS Path 1

Span: 30 MHz to 1 GHz

RBW/VBW: 300 kHz

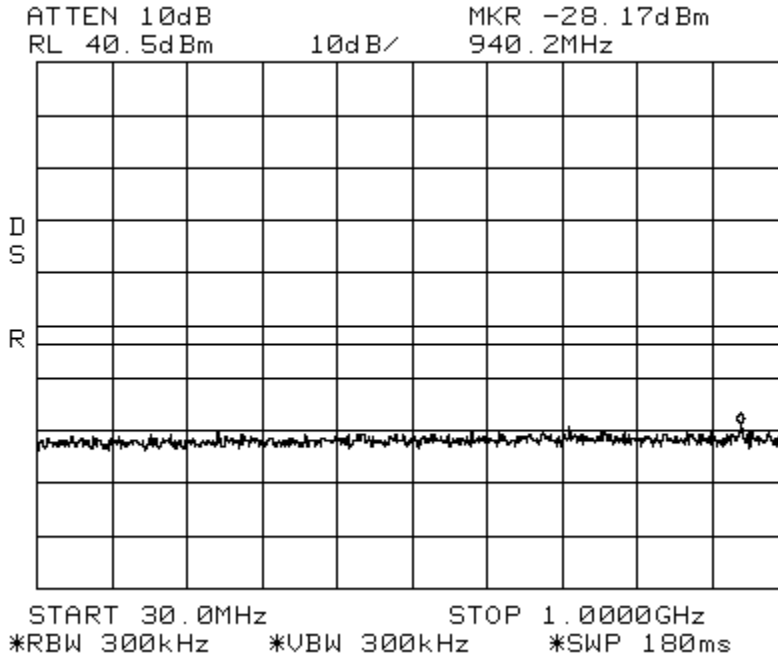

Intermodulation

WCDMA_Apart

Spectrum PCS Path 1

Span: 1 GHz to 20 GHz

RBW/VBW: 1 MHz

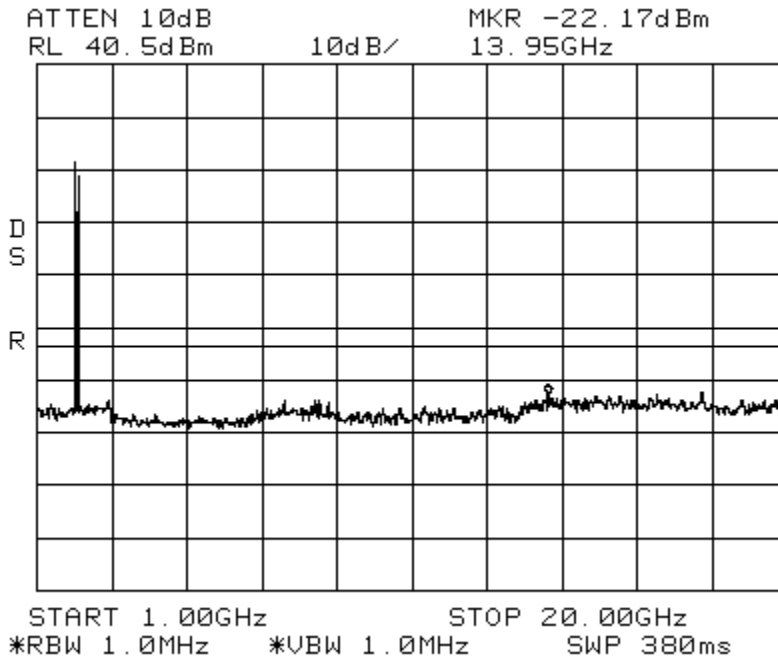

7.5 Occupied Bandwidth Modulation Test

[Table of Contents; Section 1.0](#)

[Back to Emission Limits; Section 5.1.3](#)

An input/output Occupied Bandwidth test was done with modulation types: CDMA, GSM, EDGE, WCDMA, LTE 3MHz, LTE 5MHz, LTE 10MHz, LTE 15MHz, & LTE 20MHz. The purpose was to determine the amount of distortion added to different types of modulation schemes by the EUT. The following plots show input signals vs. output signals.

The resolution bandwidth is reduced to 1% of the estimated emission bandwidth and the video bandwidth is set to 3 times the resolution bandwidth. The markers are moved to the -20 dB points (from the previously established center frequency level) on either side of center frequency.

Results:

Pass (see plots)

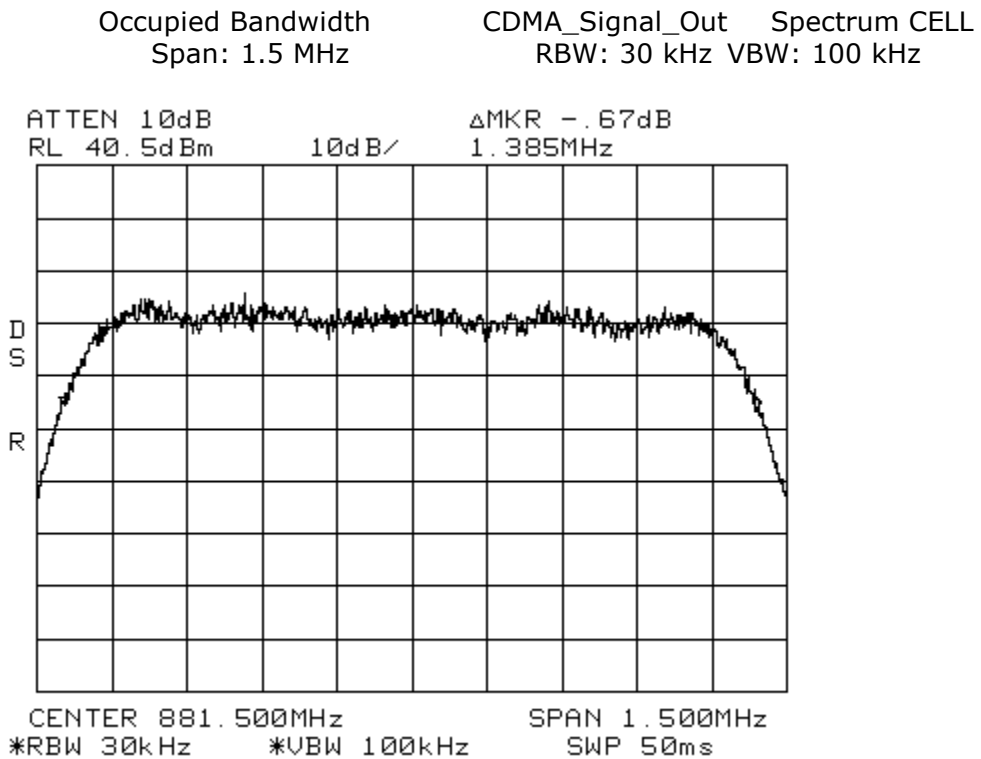
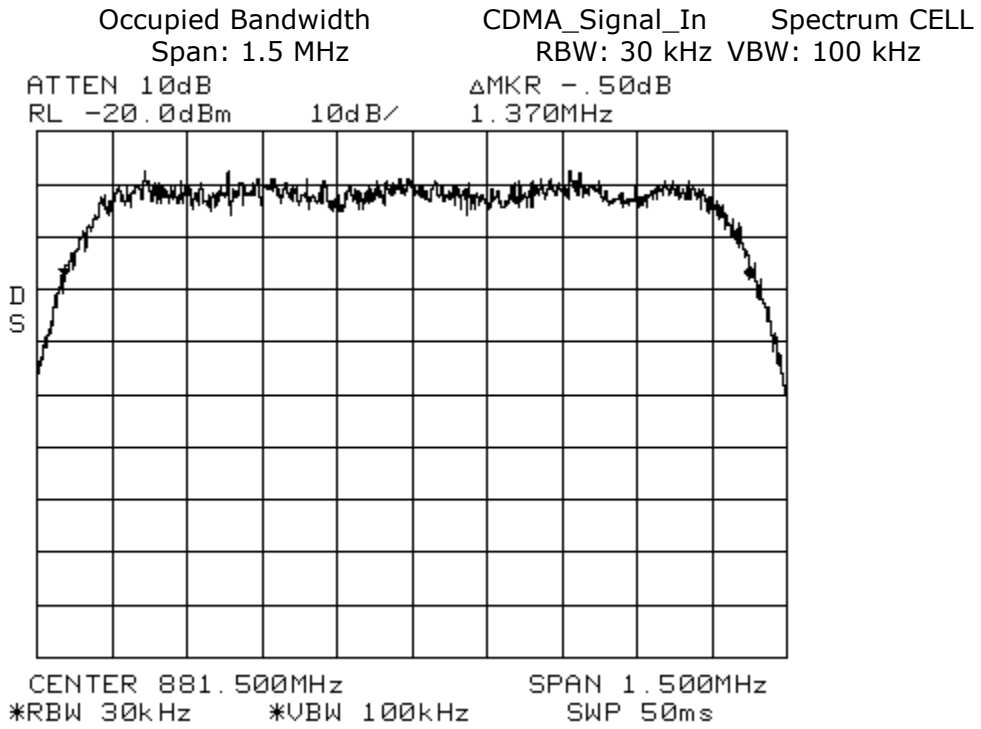

Occupied Bandwidth
Span: 350 kHz

GSM_Signal_In
RBW: 3 kHz VBW: 10 kHz

Spectrum CELL

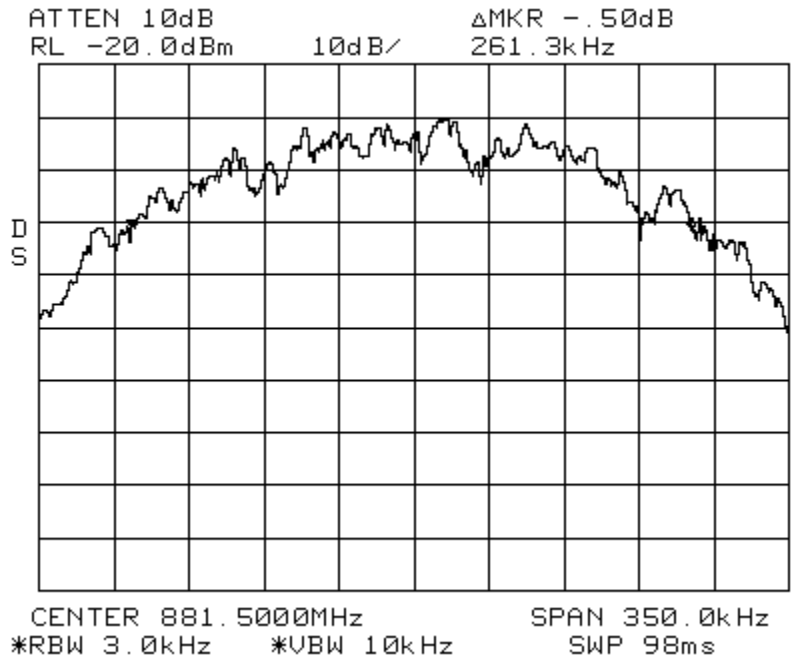

Occupied Bandwidth
Span: 350 kHz

GSM_Signal_Out
RBW: 3 kHz VBW: 10 kHz

Spectrum CELL

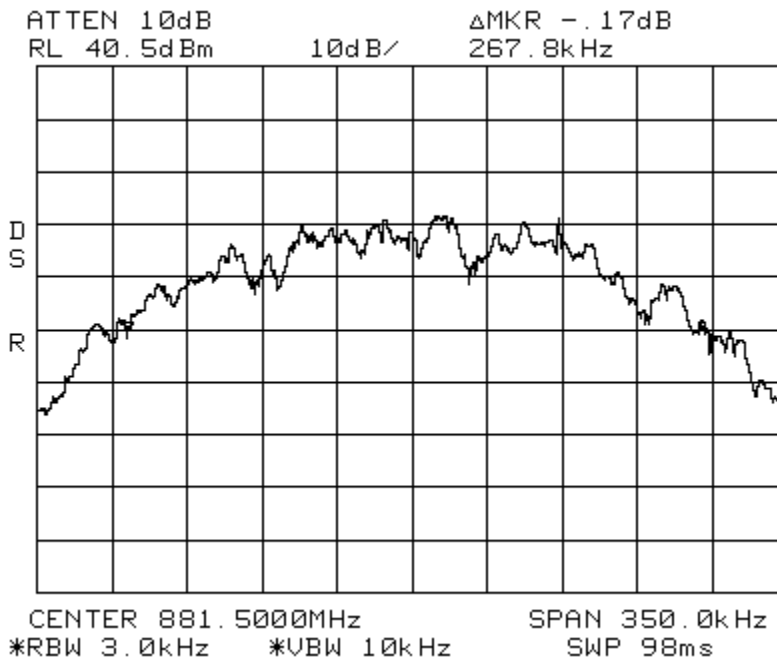

Occupied Bandwidth

LTE 3 MHz Channel Bandwidth_Signal_In

Spectrum CELL

Span: 3 MHz

RBW: 30kHz VBW: 100 kHz

ATTEN 10dB

Δ MKR .33dB

RL -20.0dBm

10dB/

2.900MHz

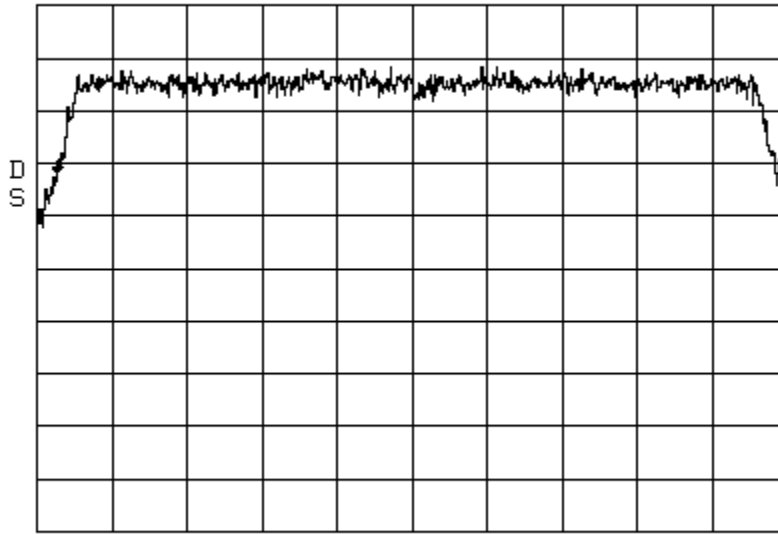

CENTER 881.500MHz SPAN 3.000MHz
*RBW 30kHz *VBW 100kHz SWP 50ms

Occupied Bandwidth

LTE 3 MHz Channel Bandwidth_Signal_Out

Spectrum CELL

Span: 3 MHz

RBW: 30 kHz VBW: 100 kHz

ATTEN 10dB

Δ MKR .34dB

RL 40.5dBm

10dB/

2.855MHz

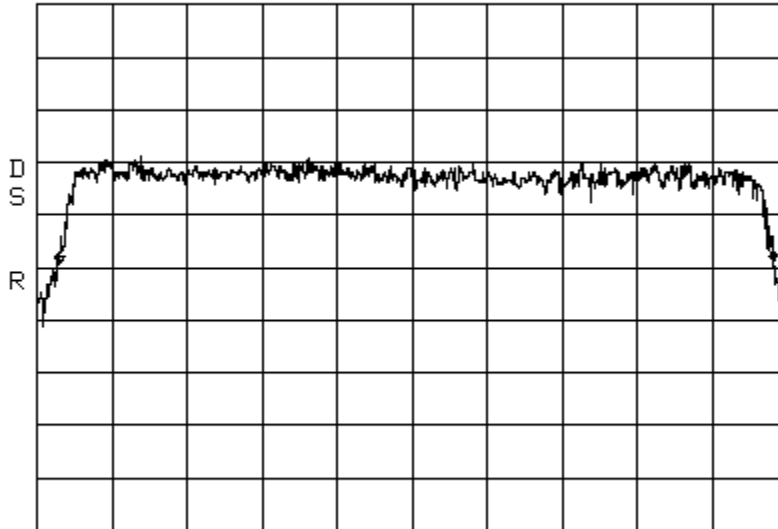

CENTER 881.500MHz SPAN 3.000MHz
*RBW 30kHz *VBW 100kHz SWP 50ms

Occupied Bandwidth

LTE 5 MHz Channel Bandwidth_Signal_In
Span: 5 MHz RBW: 30 kHz VBW: 100 kHz

Spectrum CELL

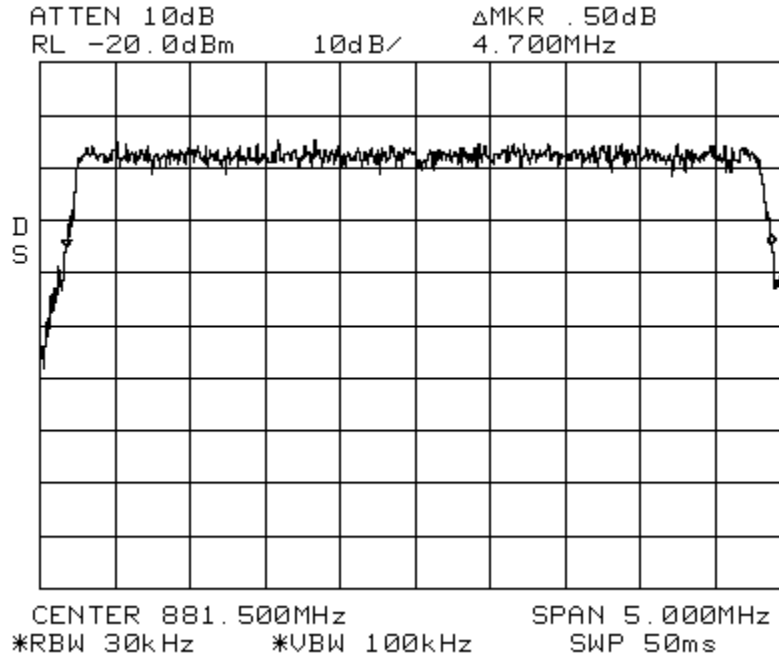

Occupied Bandwidth

LTE 5 MHz Channel Bandwidth_Signal_Out
Span: 5 MHz RBW: 30 kHz VBW: 100 kHz

Spectrum CELL

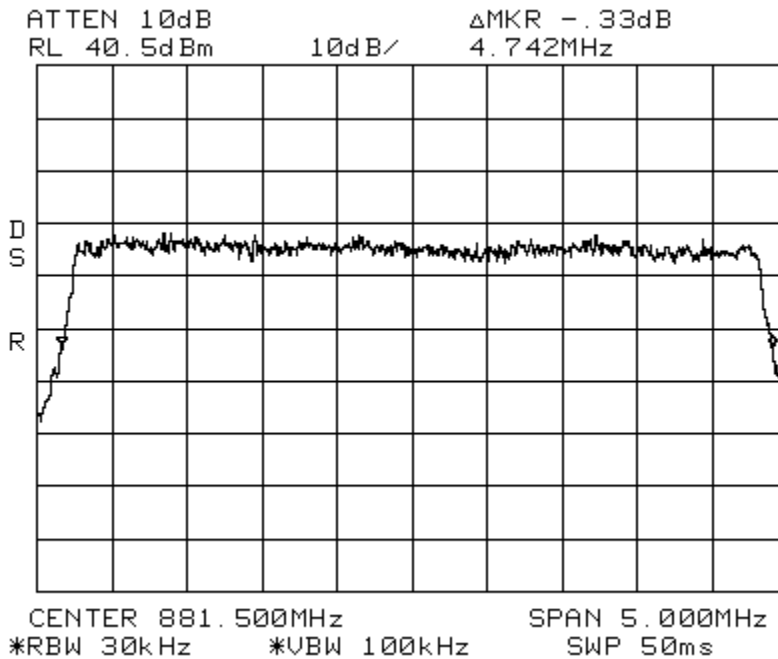

Occupied Bandwidth

LTE 10 MHz Channel Bandwidth_Signal_In
Span: 10 MHz RBW: 30 kHz VBW: 100 kHz

Spectrum CELL

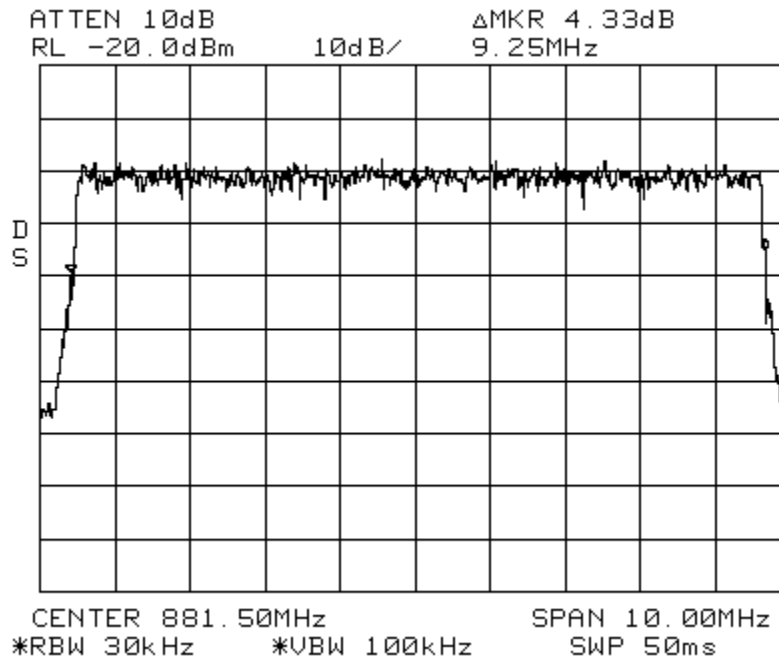

Occupied Bandwidth

LTE 10 MHz Channel Bandwidth_Signal_Out
Span: 10 MHz RBW: 30 kHz VBW: 100 kHz

Spectrum CELL

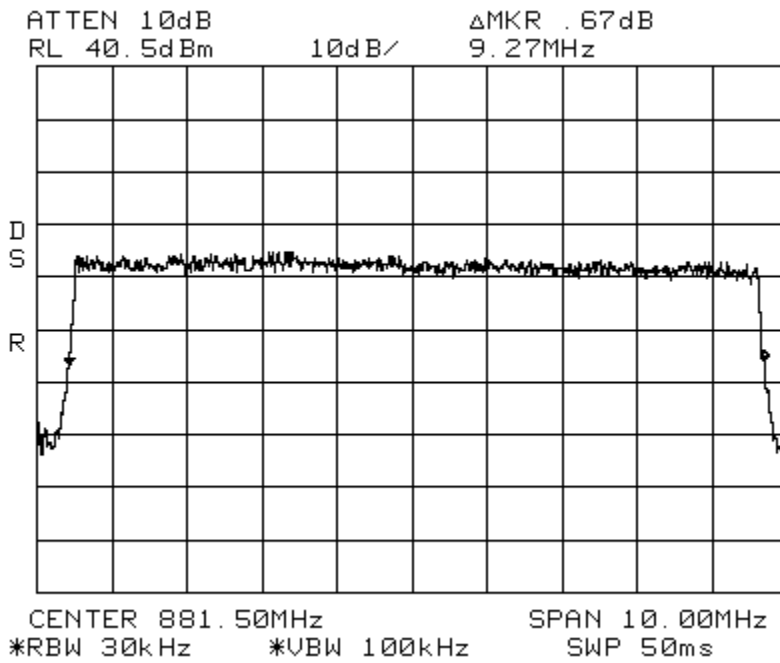

Occupied Bandwidth
Span: 5 MHz

WCDMA_Signal_In
RBW: 30 kHz VBW: 100 kHz

Spectrum CELL

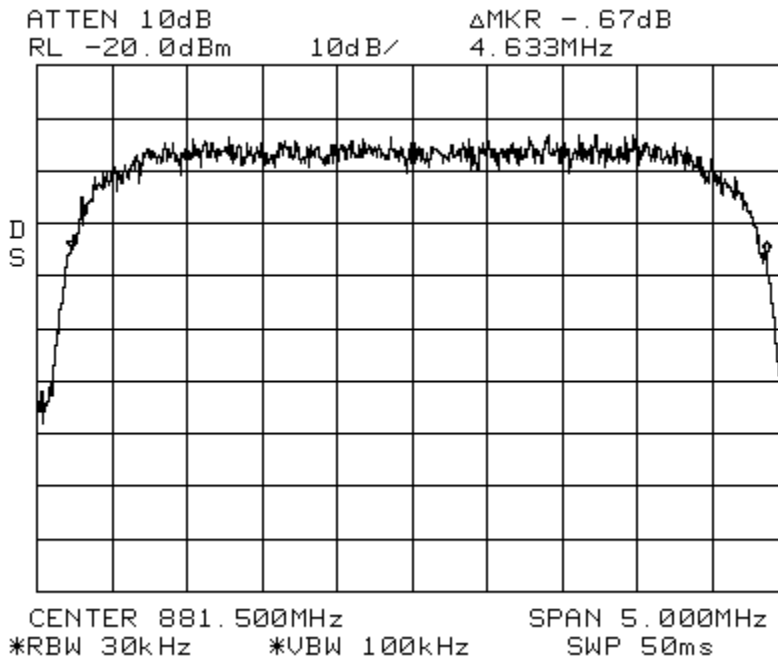

Occupied Bandwidth
Span: 5 MHz

WCDMA_Signal_Out
RBW: 30 kHz VBW: 100 kHz

Spectrum CELL

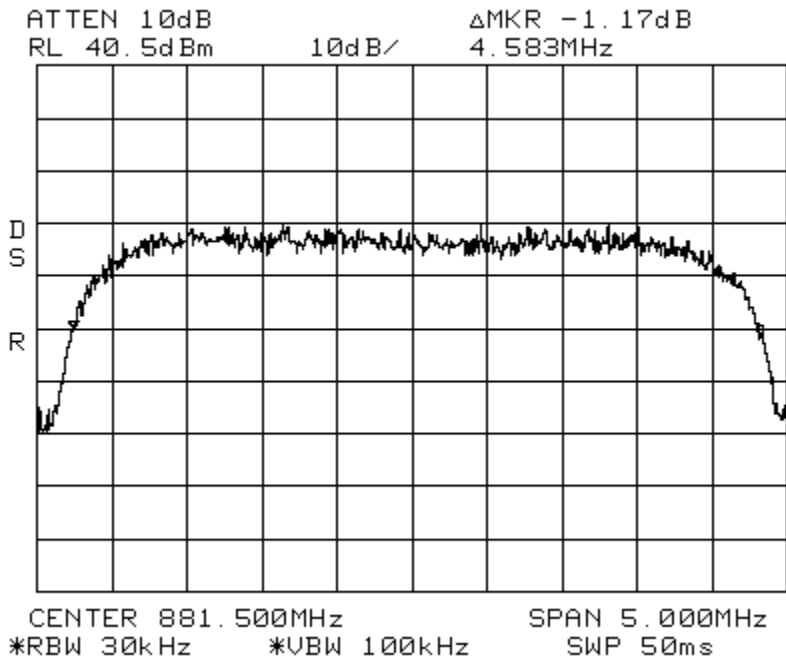

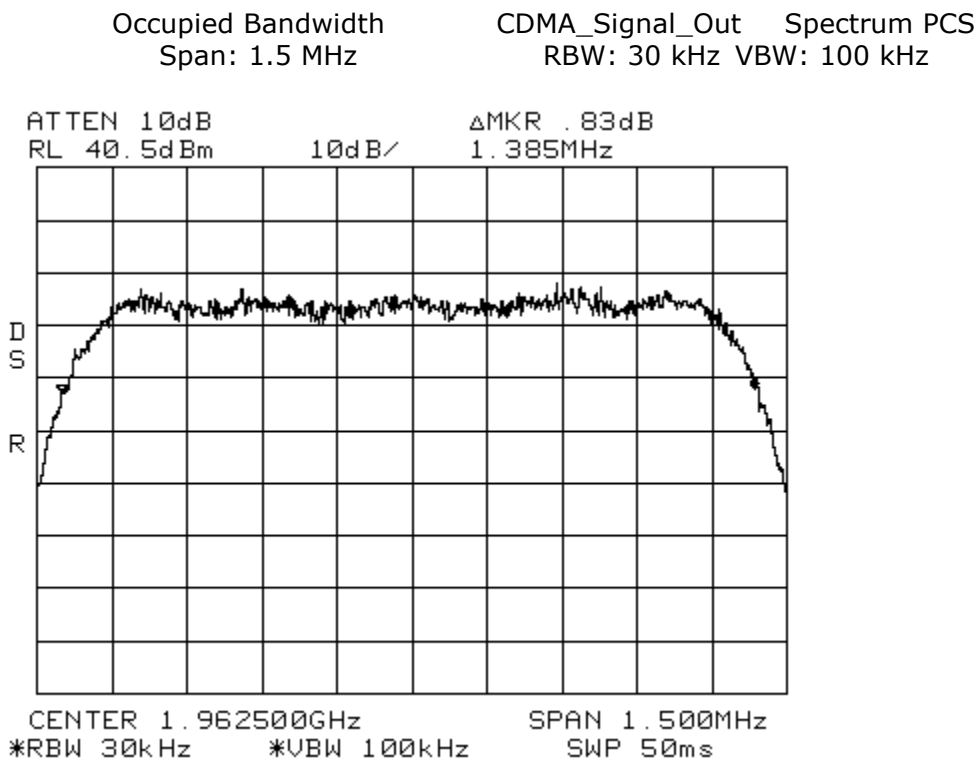
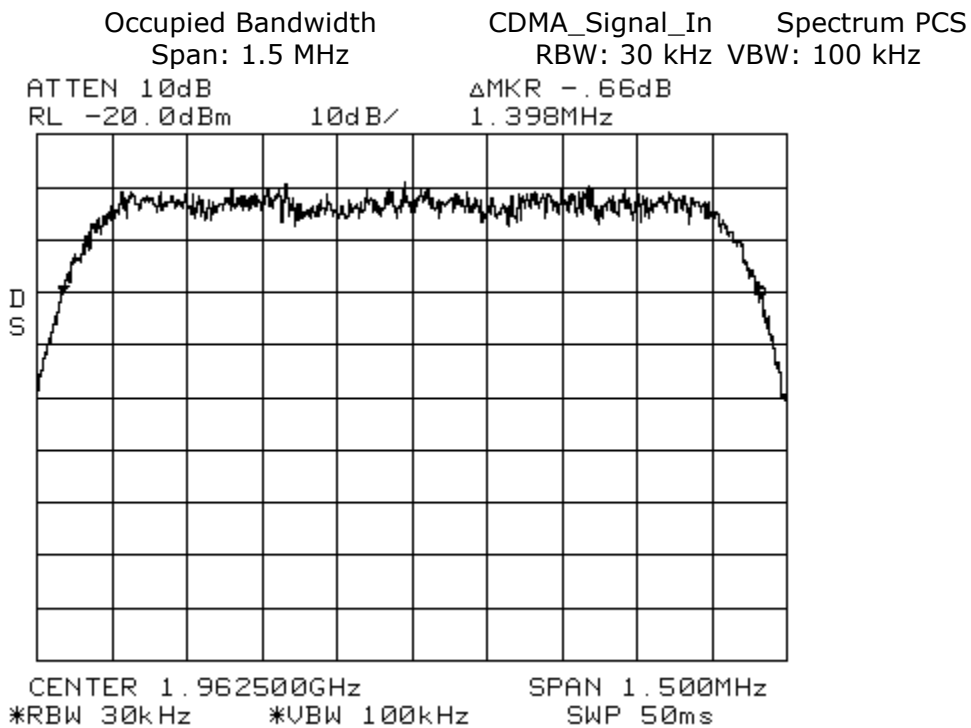

Occupied Bandwidth
Span: 350 kHz

EDGE_Signal_In Spectrum PCS
RBW: 3 kHz VBW: 10 kHz

ATTEN 10dB ΔMKR -.33dB
RL -20.0dBm 10dB/ 262.5kHz

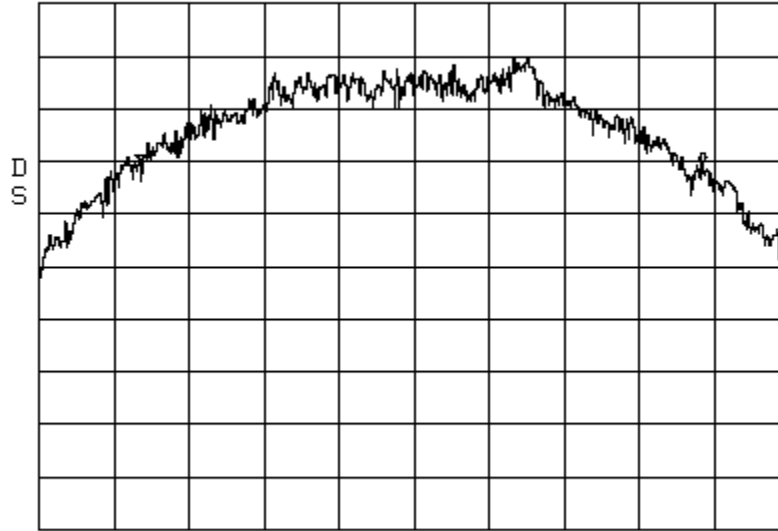

CENTER 1.9625000GHz SPAN 350.0kHz
*RBW 3.0kHz *VBW 10kHz SWP 98ms

Occupied Bandwidth
Span: 350 kHz

EDGE_Signal_Out Spectrum PCS
RBW: 3 kHz VBW: 10 kHz

ATTEN 10dB ΔMKR .33dB
RL 40.5dBm 10dB/ 261.3kHz

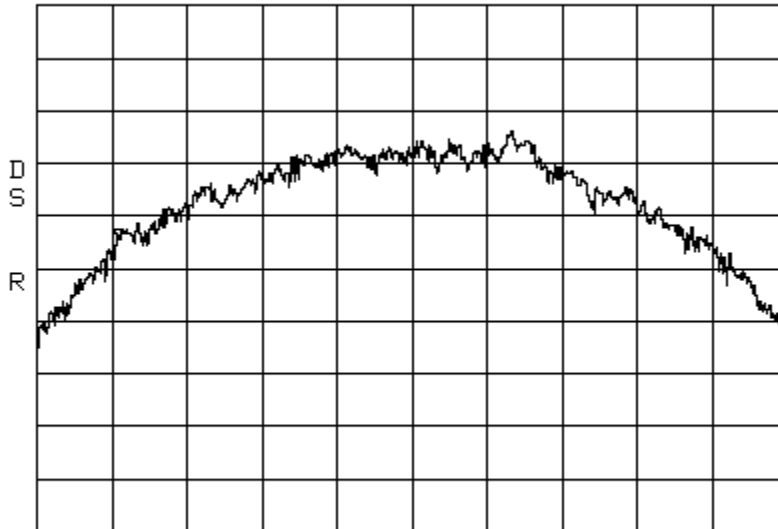

CENTER 1.9625000GHz SPAN 350.0kHz
*RBW 3.0kHz *VBW 10kHz SWP 98ms

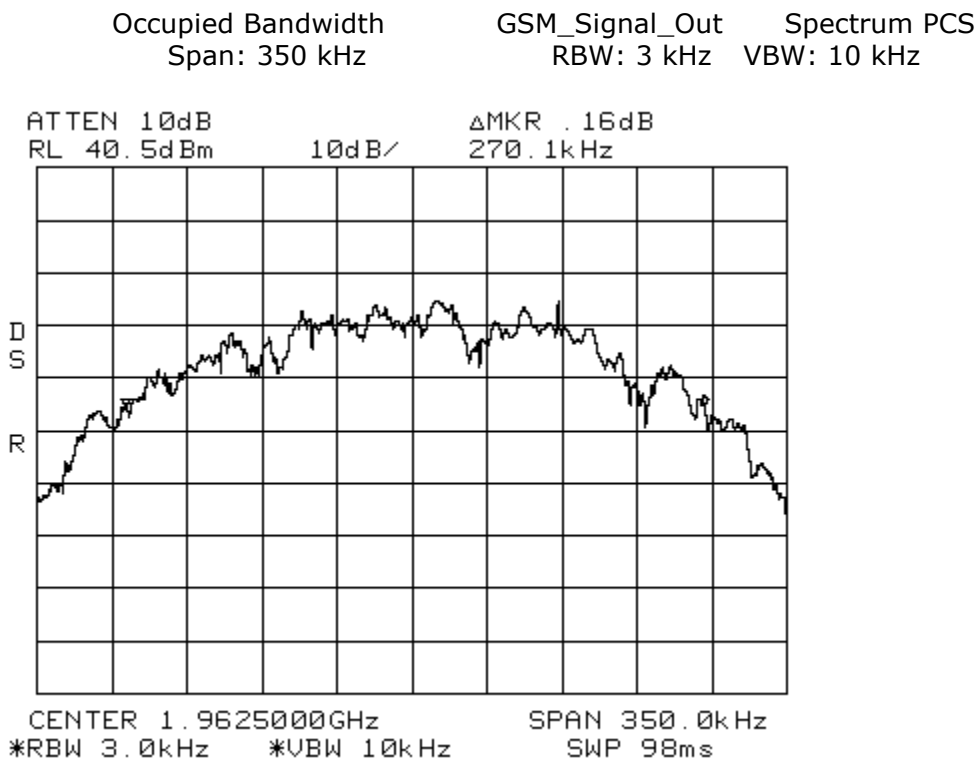
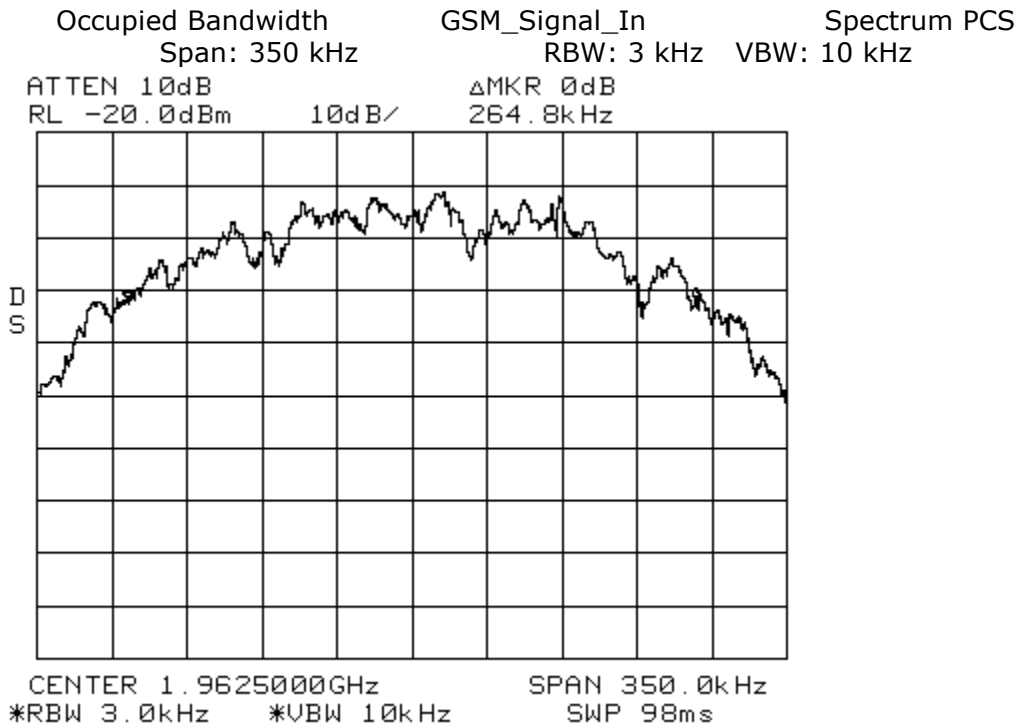

Occupied Bandwidth

LTE 3 MHz Channel Bandwidth_Signal_In

Spectrum PCS

Span: 3 MHz

RBW: 30kHz VBW: 100 kHz

ATTEN 10dB

Δ MKR .17dB

RL -20.0dBm

10dB/

2.850MHz

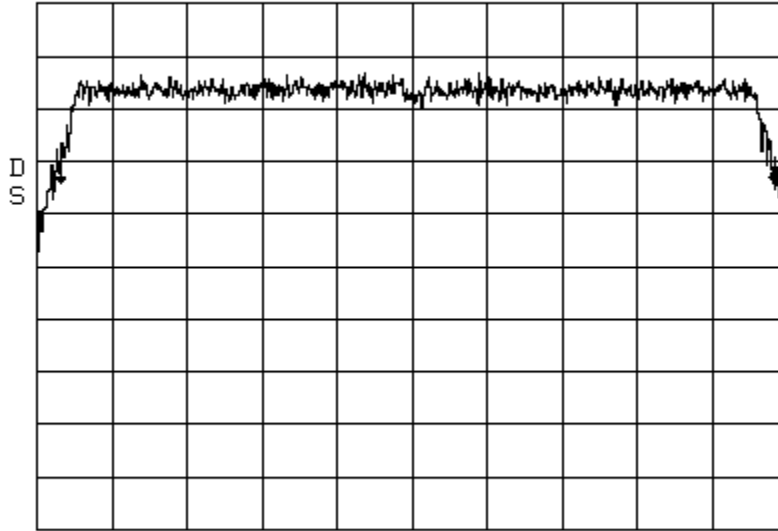

CENTER 1.962500GHz SPAN 3.000MHz
*RBW 30kHz *VBW 100kHz SWP 50ms

Occupied Bandwidth

LTE 3 MHz Channel Bandwidth_Signal_Out

Spectrum PCS

Span: 3 MHz

RBW: 30 kHz VBW: 100 kHz

ATTEN 10dB

Δ MKR -.33dB

RL 40.5dBm

10dB/

2.855MHz

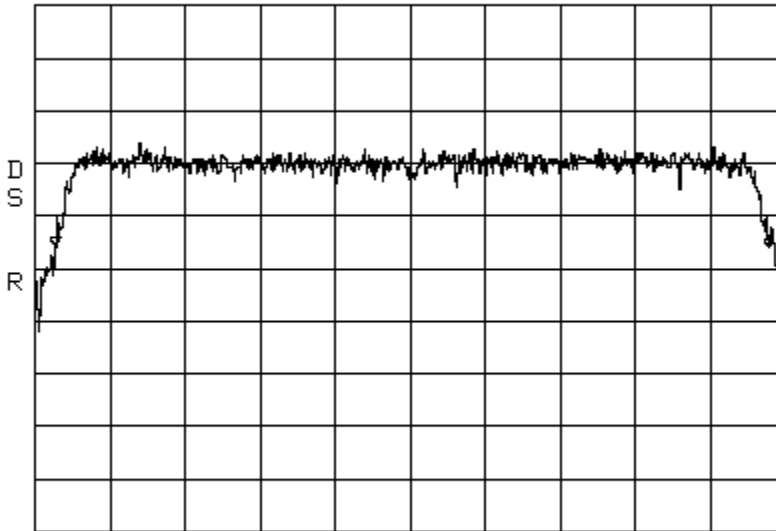

CENTER 1.962500GHz SPAN 3.000MHz
*RBW 30kHz *VBW 100kHz SWP 50ms

Occupied Bandwidth LTE 5 MHz Channel Bandwidth_Signal_In Spectrum PCS
Span: 5 MHz RBW: 30 kHz VBW: 100 kHz

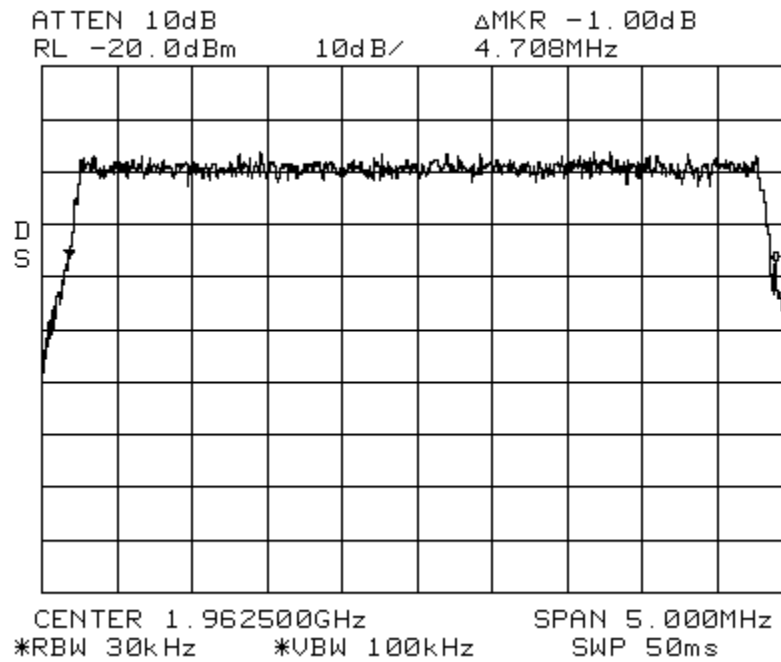

Occupied Bandwidth LTE 5 MHz Channel Bandwidth_Signal_Out Spectrum PCS
Span: 5 MHz RBW: 30 kHz VBW: 100 kHz

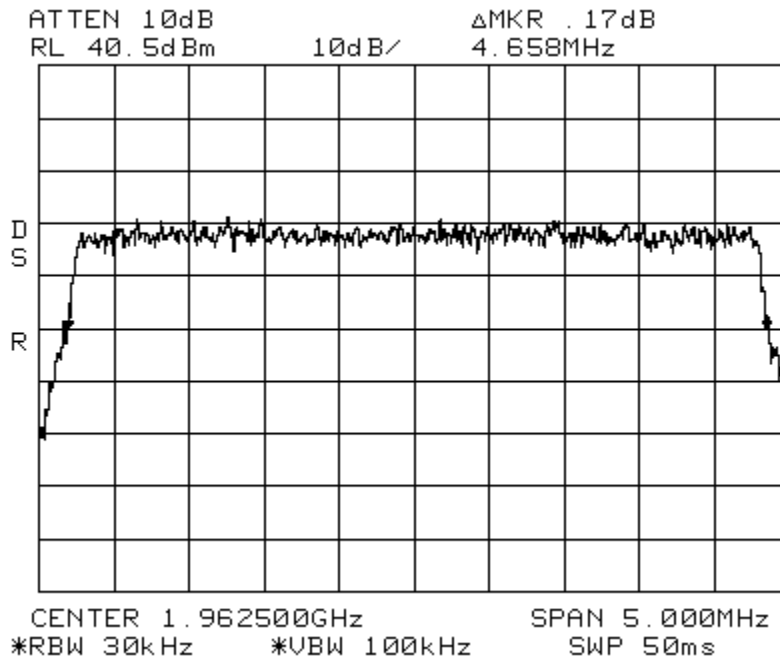

Occupied Bandwidth LTE 10 MHz Channel Bandwidth_Signal_In Spectrum PCS
Span: 10 MHz RBW: 30 kHz VBW: 100 kHz

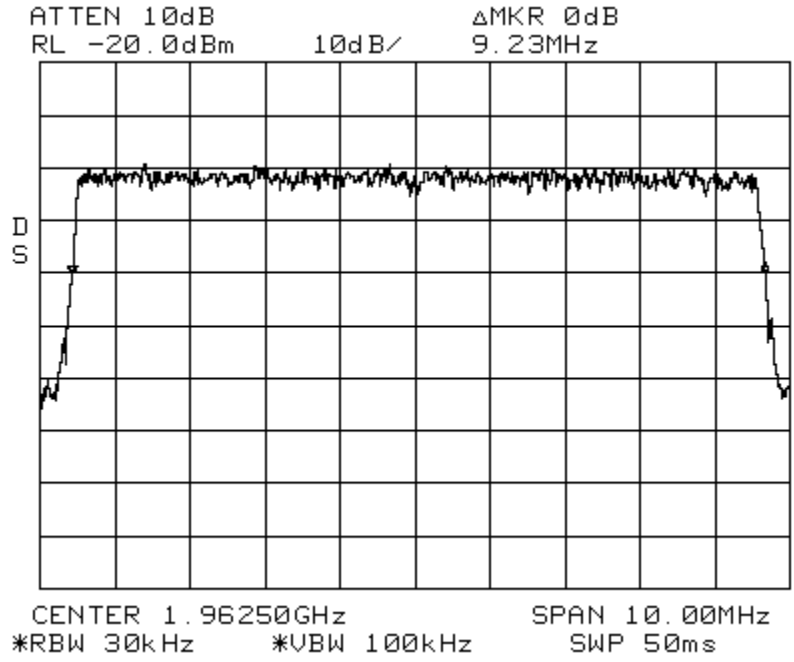

Occupied Bandwidth LTE 10 MHz Channel Bandwidth_Signal_Out Spectrum PCS
Span: 10 MHz RBW: 30 kHz VBW: 100 kHz

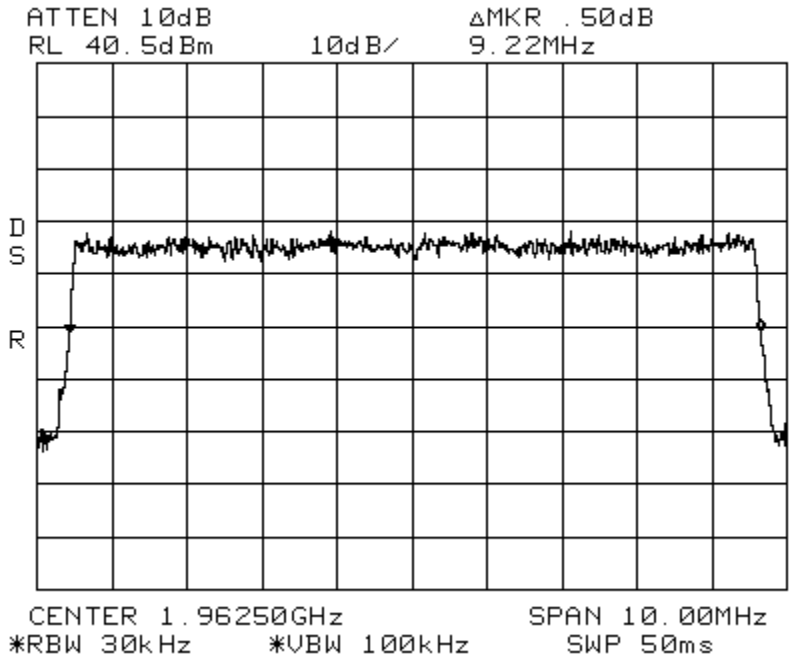

Occupied Bandwidth

LTE 15 MHz Channel Bandwidth_Signal_In
Span: 15 MHz RBW: 30 kHz VBW: 100 kHz

Spectrum PCS

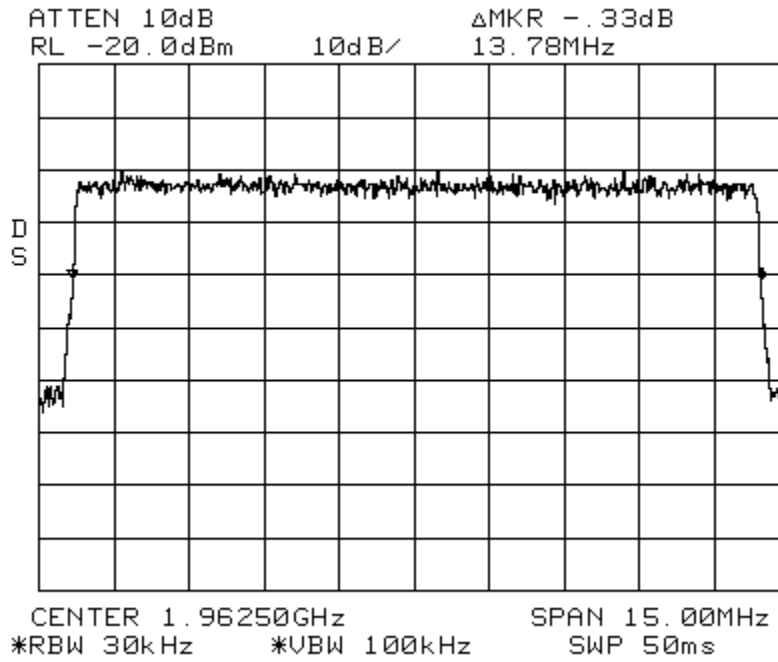

Occupied Bandwidth

LTE 15 MHz Channel Bandwidth_Signal_Out
Span: 15 MHz RBW: 30 kHz VBW: 100 kHz

Spectrum PCS

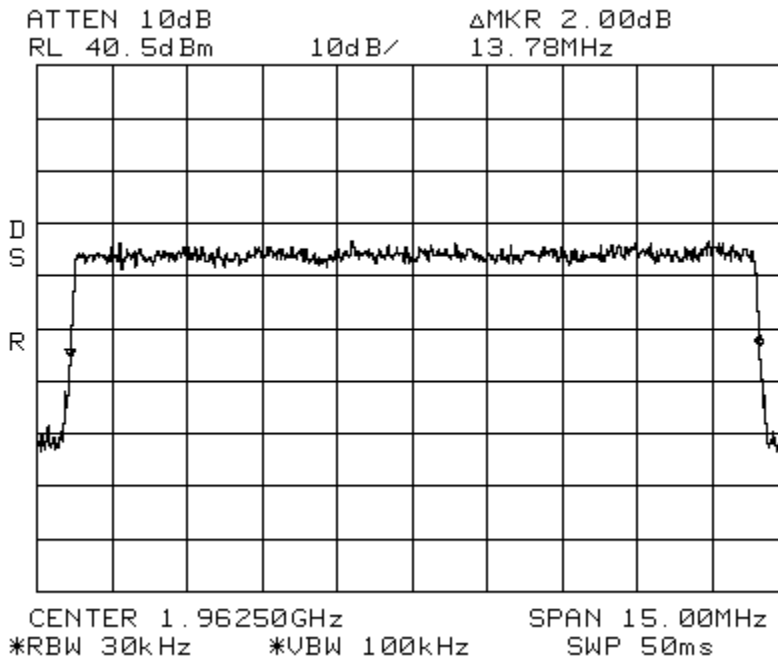

Occupied Bandwidth

LTE 20 MHz Channel Bandwidth_Signal_In
Span: 20 MHz RBW: 30 kHz VBW: 100 kHz

Spectrum PCS

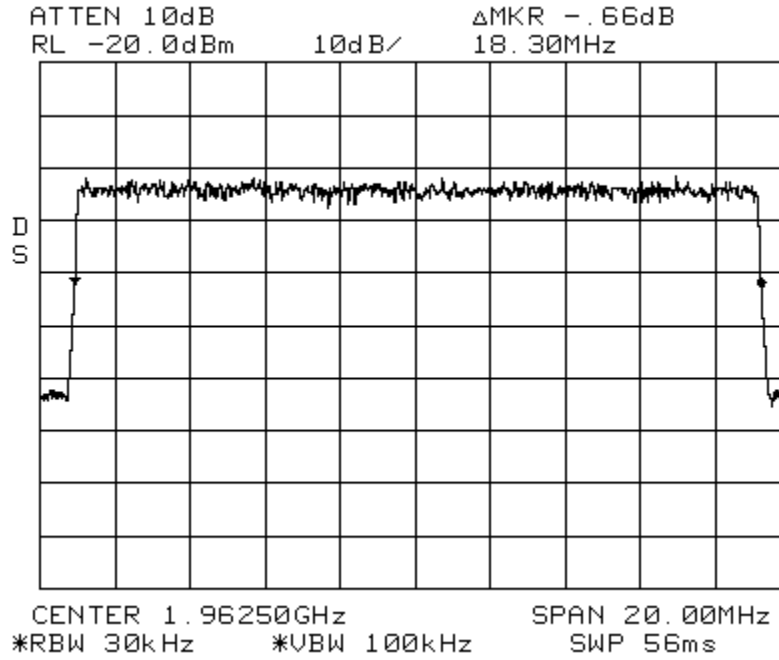

Occupied Bandwidth

LTE 20 MHz Channel Bandwidth_Signal_Out
Span: 20 MHz RBW: 30 kHz VBW: 100 kHz

Spectrum PCS

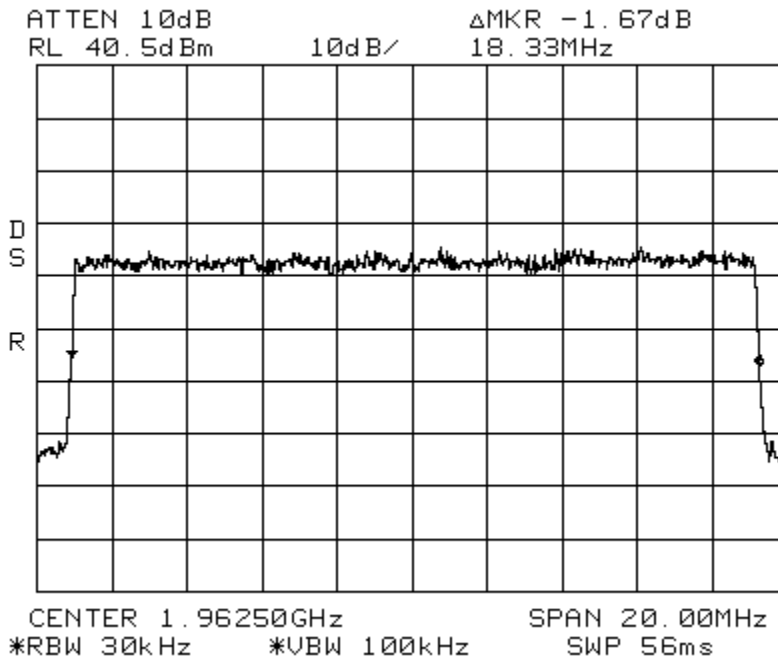

Occupied Bandwidth WCDMA_Signal_In Spectrum PCS
Span: 5 MHz RBW: 30 kHz VBW: 100 kHz

ATTEN 10dB ΔMKR -.34dB
RL -20.0dBm 10dB/ 4.550MHz

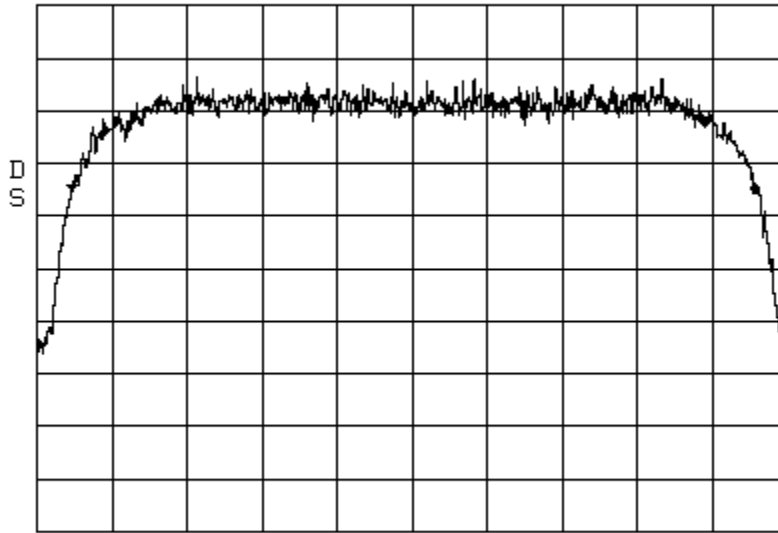

CENTER 1.962500GHz SPAN 5.000MHz
*RBW 30kHz *VBW 100kHz SWP 50ms

Occupied Bandwidth WCDMA_Signal_Out Spectrum PCS
Span: 5 MHz RBW: 30 kHz VBW: 100 kHz

ATTEN 10dB ΔMKR -.34dB
RL 40.5dBm 10dB/ 4.533MHz

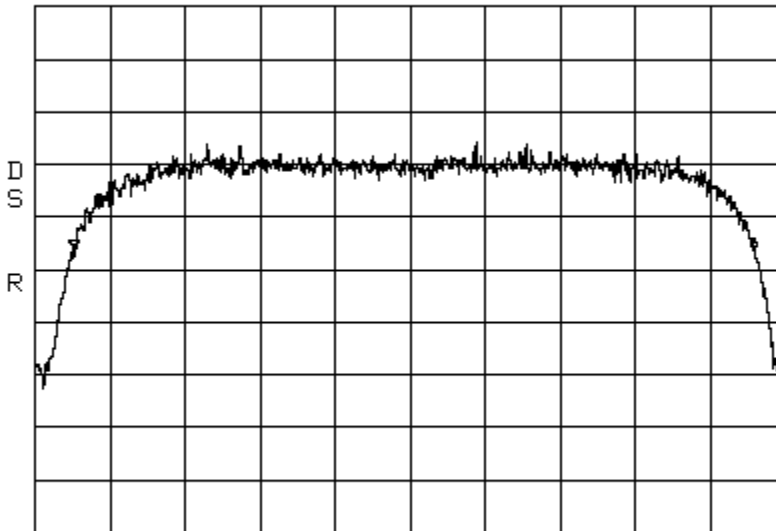

CENTER 1.962500GHz SPAN 5.000MHz
*RBW 30kHz *VBW 100kHz SWP 50ms

8.0

APPENDIX B

Measurement Protocol

[Table of Contents; Section 1.0](#)
[Back to Emission Limits; Section 5.1.3](#)

Measurement Protocol

Environmental conditions of the lab, (ADC)

Temperature: 25° C

Relative Humidity: 30 %

Atmospheric Pressure: 98.2 kPa

Test Methodology:

Emission testing is performed according to the procedures in ANSI C63.4-2003.

Measurement Uncertainty

The test system for conducted emissions is defined as the signal generator(s), the power meter, the spectrum analyzer and the coaxial cable. The equipment comprising the test systems is calibrated prior to testing the EUT.

Justification

The Equipment Under Test (EUT) is configured in a typical user arrangement in accordance with the manufacturer's instructions. A cable is connected to each available port and either terminated with a peripheral into its characteristic impedance or left un-terminated. When appropriate, the cables are manually manipulated with respect to each other to obtain maximum emissions from the unit.

Radiated Emissions

The final level, in dBuV/m, equals the reading from the spectrum analyzer (Level dBuV), adding the antenna correction factor and cable loss factor (Factor dB) to it, and subtracting the preamp gain (and duty cycle correction factor, if applicable). This result then has the limit subtracted from it to provide the Delta, which gives the tabular data as shown in the data sheets in Appendix B.

Example:

FREQ (MHz)	LEVEL (dBuV)	CABLE/ANT/PREAMP (dB) (dB/m) (dB)	FINAL (dBuV/m)	POL/HGT/AZ (m) (deg)	DELTA1
60.80	42.5Qp +	1.2 + 10.9 - 25.5 =	29.1	V 1.0 0.0	-10.9

Substitution Method

A cabinet (or enclosure) radiated emission scan was also made, at Intertek, with the EUT's antenna replaced with a termination to demonstrate case radiation compliance to the -13 dBm requirement. Radiated emissions from the EUT are measured in the frequency range of 30 to 20,000 MHz using a spectrum analyzer and appropriate broadband linearly polarized antennas. Table top equipment is placed on a 1.0 X 1.5 meter non-conducting table 80 centimeters above the ground plane. Floor standing equipment is placed directly on the turntable/ground plane. Interface cables that are closer than 40 centimeters to the ground plane are bundled in the center in a serpentine fashion so they are at least 40 centimeters from the ground plane. Cables to simulators/testers (if used in this test) are routed through the center of the table and to a screen room located outside the test area. The antenna is positioned 3 meters horizontally from the EUT. To locate maximum emissions from the test sample the antenna is varied in height from 1 to 4 meters, measurement scans are made with both horizontal and vertical antenna polarizations and the EUT are rotated 360 degrees. The field strength levels were measured per ANSI C63.4. The EUT is then replaced with a tuned dipole antenna (below 1GHz) or horn antenna (above 1 GHz). The substitute antenna was placed in the same polarization as the test antenna. A signal generator was used to generate a signal level that matched the highest level measured from the EUT. The signal generator level minus the cable loss from the signal generator to the substitute antenna plus the substitute antenna gain equals the spurious power level.

Test Equipment

All measurement instrumentation is traceable to the National Institute of Standards and Technology and is calibrated according to internal procedure.

Radiated Emissions Test Data

[Table of Contents; Section 1.0](#)

Document Name: **100779277MIN-001**

Test Engineer: Richard Blonigen

Date: June 14, 2012

Test Procedure:

Test measurements were made in accordance with ANSI C63.4-2003, Standard Methods of Measurement of Radio Noise Emissions from Low-Voltage Electrical and Electronics Equipment in the Range of 9 kHz to 40 GHz.

Test Site Location:

The test site is a 3 meter Semi-Anechoic Chamber, constructed by Panashield™ Inc. and located inside the building at 7250 Hudson Blvd. Suite 100, Oakdale, MN 55128.

Test Site Description:

The 3 meter Semi-Anechoic Chamber is constructed of Panabolt™ modular RF shielding and self-supported with structural steel designed for the local seismic zone rating. The chamber has the nominal size of 20' wide x 29' long x 18' high. All walls and ceiling of the chamber are treated with FFG-1000 Ferrite Grid absorber which was developed specifically to meet international requirements for EMC anechoic chambers for emissions and immunity measurements. To meet high frequency testing white HY-35 hybrid absorber is mounted on the ferrites in specular regions of the chamber.

The chamber has a 2 meter diameter ANSI test volume area and meets the requirements of ANSI C63.4 (1992), EN55022, and FCC Part 15 standards for testing at a 3 meter path length.

FCC Registration Number: 0007355381

IC Registration Number: 4359A