

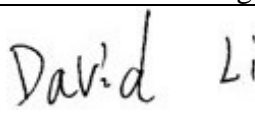
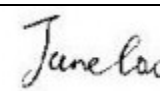
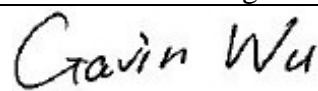

TEST REPORT

Report No.:	EM201200597	Application No.:	ZJ00021997
Client:	ADC Telecommunications, INC		
Address:	P.O. Box 1101, Minneapolis, Minnesota		
Sample Description:	InterReach Fusion® 700 MHz (Lower ABC), AWSMIMO HP		
Model:	FSN-W4-702121-1-HP		
Test Location:	EMC Laboratory of Guangzhou GRG Metrology and Test Co., Ltd.		
Test Specification:	FCC PART 27		
Issue Date:	2012-11-20		
Test Result:	Pass.		
Prepared By:	Reviewed By:	Approved By:	
David Li/ Test Engineer	Jane Cao/ Engineer	Gavin Wu / Manager	
 Date:2012-11-20	 Date:2012-11-20	 Date:2012-11-20	
Other Aspects:			
None			
Abbreviations: ok / P = passed; fail / F = failed; n.a. / N = not applicable			
The test result in this test report refers exclusively to the presented test sample. This report shall not be reproduced except in full, without the written approval of GRGT.			

DIRECTIONS OF TEST

- 1. This station carries out test task according to the national regulation of verifications which can be traced to National Primary Standards and BIPM.**

- 2. The test report merely corresponds to the test sample. It is not permitted to copy extracts of these test result without the written permission of the test laboratory.**

- 3. If there is any objection concerning the test, the client should inform the laboratory within 15 days from the date of receiving the test report.**

TABLE OF CONTENTS

1 . TEST SUMMARY	4
2 . GENERAL INFORMATION	5
2.1 CLIENT INFORMATION	5
2.2 MANUFACTURER	5
2.3 BASIC DESCRIPTION OF EUT	5
2.4 STANDARDS APPLICABLE FOR TESTING.....	5
2.5 TEST LOCATION	6
2.6 ACCREDITATION.....	6
2.7 OTHER INFORMATION REQUESTED BY THE CUSTOMER	6
3 . EQUIPMENTS USED DURING TEST	7
<i>FILTER</i>	7
4. TEST RESULTS	9
4.1 EUT OPERATION	9
4.2 TEST PROCEDURE & MEASUREMENT DATA	12
4.2.1 <i>RF OUTPUT POWER</i>	12
4.2.1.1 MEASUREMENT RECORD	14
4.2.2 <i>CONDUCTED SPURIOUS EMISSIONS</i>	16
4.2.2.1 MEASUREMENT RECORD	19
4.2.3 <i>BAND EDGE</i>	85
4.2.3.1 MEASUREMENT RECORD	87
4.2.4 <i>RADIATED SPURIOUS EMISSIONS</i>	98
4.2.4.1 MEASUREMENT RECORD	102
4.2.5 <i>OCCUPIED BANDWIDTH</i>	103
4.2.5.1 MEASUREMENT RECORD	104
4.2.6 <i>INTERMODULATION</i>	170
4.2.6.1 MEASUREMENT RECORD	173
4.2.7 <i>FREQUENCY STABILITY</i>	188
4.2.7.1 MEASUREMENT RECORD	189
APPENDIX A:PHOTOGRAPH OF THE TEST CONFIGURATION.....	191
APPENDIX B: PHOTOGRAPHS OF EUT.....	193

1 . TEST SUMMARY

Test Item	Test Requirement	Test Method	Result
Output Power	FCC part 27.50	FCC part 2.1046 2-11-04/EAB/RF § 27.50(i) TIA/EIA 603C	PASS
Conducted Spurious Emission	FCC part 27.53	FCC part 2.1051 2-11-04/EAB/RF § 27.53(c) TIA/EIA 603C	PASS
Band Edge	FCC part 27.53	FCC part 2.1051 2-11-04/EAB/RF § 27.53(c) TIA/EIA 603C	PASS
Radiated Spurious Emission	FCC part 27.53	FCC part 2.1053 2-11-04/EAB/RF § 27.53(c) TIA/EIA 603C	PASS
Occupied Bandwidth	2-11-04/EAB/RF	FCC part 2.1049 2-11-04/EAB/RF 27.53(c) TIA/EIA 603C	PASS
Intermodulation	FCC part 27.53	2-11-04/EAB/RF TIA/EIA 603C	PASS
Frequency Stability	FCC part 27.54	FCC part 2.1055 § 27.54 TIA/EIA 603C	PASS

Remark:

Tx: In this whole report Tx (or tx) means Transmitter .

Rx: In this whole report Rx (or rx) means Receiver.

2 . GENERAL INFORMATION

2.1 CLIENT INFORMATION

Name: ADC Telecommunications, INC
Address: P.O. Box 1101, Minneapolis, Minnesota

2.2 MANUFACTURER

Name: FLEXTRONICS TECH. (SHANGHAI) CO LTD
Address: NO.77, YONG SHENG, JIADING ROAD, MALU, JIADING, SHANGHAI, CHINA 201801

2.3 BASIC DESCRIPTION OF EUT

Equipment: InterReach Fusion® 700 MHz (Lower ABC), AWSMIMO HP

Model No.: Main Hub: FSN-W4-MH-1MH-1
EHub: FSN-W1-EH-2
RAU: FSN-W4-702121-1-HP

Power Supply: Main Hub and Ehub: AC 100-240V 50/60Hz

Power Supply: RAU:DC 54V (from the Fusion Expansion Hub via the same coax cable)

Adapter N/A

Power Cord 1.5m unscrewed AC power cord

Type of Modulation WCDMA,LTE

Frequency Band 700MHz Band :728MHz-746MHz downlink,698MHz-716MHz uplink
AWS1 Band:2110MHz-2155MHz downlink,1710MHz-1755MHz uplink
AWS2 Band:2110MHz-2155MHz downlink ,1710MHz-1755MHz uplink

Antenna Type N/A

2.4 STANDARDS APPLICABLE FOR TESTING

The standard used FCC part 27

2.5 TEST LOCATION

The tests and measurements refer to this report were performed by Guangzhou GRG Metrology and Test Co., Ltd.

Add. : 163 Pingyun Rd, West of Huangpu Ave, Guangzhou, 510656, P. R. China

Telephone: +86-20-38699959, 38699960, 38699961

Fax : +86-20-38695185

2.6 ACCREDITATION

Our laboratories are accredited and approved by the following approval agencies according to ISO/IEC 17025.

USA	FCC Listed Lab No. 688188
China	CNAS NO.L0446
China	DILAC No.DL175
Canada	Registration No.:8355A-1

2.7 OTHER INFORMATION REQUESTED BY THE CUSTOMER

N/A

3 . EQUIPMENTS USED DURING TEST

Name of Equipment	Manufacturer	Model	Serial Number	Calibration Due
Radiated Spurious Emission				
Spectrum Analyzer	R&S	ESU40	100106	2013-09-26
Biconical antenna	ELECTRO-METRICS	BIA-30S	166	2013-10-14
log-periodical antenna	ELECTRO-METRICS	LPA-30	383	2013-07-30
Horn antenna	ETS.LINDGREN	3117	00075824	2013-08-20
Horn antenna	SCHWARZBECK	BBHA9120D	D752	2013-10-14
Signal Generator	R&S	SML03	103002	2013-09-02
FILTER	TELONIC	TTR95-3EE	50076	2013-09-06

Output Power/ Conducted Spurious Emission / Occupied Bandwidth				
Spectrum Analyzer	R&S	ESU40	100106	2013-09-26
L.I.S.N	SCHWARZBECK	NSLK 8127	8127450	2013-08-21
Signal Generator	R&S	SML03	103002	2013-09-02

Intermodulation/ Band Edge				
signal generator	Agilent	N5182A	MY50141210	2013-09-26
signal generator	Agilent	E4438C	MY47272315	2013-09-26
Spectrum Analyzer	Agilent	E4408B	MY49652135	2013-09-26
Power splitter	Agilent	11667A	MY42254304	2013-09-02

Frequency Stability				
Constant temperature & humidity chamber	CEPREI	CEEC-MSJ-60BE	11015	2013-05-15
Spectrum Analyzer	R&S	ESU40	100106	2013-09-26
Signal Generator	R&S	SML03	103002	2013-09-02

4. TEST RESULTS

4.1 EUT OPERATION

Power supply:	AC 120V 60Hz
Temperature:	25.0 °C
Humidity:	50 % RH
Atmospheric Pressure:	1005mbar
Test requirement	

Fiber-optic distribution systems are a type of in-building radiation system that receives RF signals from an antenna, distributes the signal over fiber-optic cable, and then retransmits at another location for example within a building or tunnel. Most fiber-optic systems are signal boosters; however, some may be repeaters. These systems generally have two enclosures typically called host (or local or donor unit) and remote. Some systems may also have an optional expander box for fan-out to multiple remotes. The system transmits downlink signals from the remote unit to handsets, portables, or clients, and transmits uplink signals via from the host unit. Usually but not always the uplink goes through an intermediate amplifier to a “donor” antenna. Therefore both uplink and downlink must be tested, unless filing effectively documents how connection of uplink to donor antenna with or without an intermediate amplifier will be prevented, such as for always only a cabled connection to a base station. Fiber-optic systems are not amplifiers (AMP equipment class) – they are equipment class TNB or PCB. The same approval procedures also apply for multiple-enclosure systems connected by coax cable.

- 1) host unit
 - a) transmits uplink to base station via antenna thru coax, passive interface unit , or active interface unit (amplifier)
 - b) sends base-station downlink via fiber-optic or coax to remote
 - c) receives handset uplink via fiber-optic or coax from remote
 - d) optional connection to expansion unit via fiber-optic
 - e) separate FCC ID from remote, unless electrically identical
 - f) non-transmitting host unit
 - i) connects directly to a base station via coax cable but does

not connect to antenna or amplifier

- ii) Part 15 digital device subject to Verification, no FCC ID
 - 2) remote unit
 - a) receives base-station downlink via fiber-optic or coax from host, transmits via antenna to handsets
 - b) returns handset uplink via fiber-optic or coax to host
 - c) separate FCC ID from remote, unless electrically identical
 - 3) expansion unit
 - a) fiber-optic or coax from host
 - b) fiber-optic or coax fan-out to remote(s)
 - c) Part 15 digital device subject to Verification, no FCC ID
 - 4) passive interface unit
 - a) contains attenuators, splitters, combiners
 - b) coax cable connection between host and base-station
 - c) passive device, no FCC ID
 - 5) active interface unit
 - a) amplifies uplink signal from host unit for transmit by donor antenna
 - b) attenuates downlink from donor antenna
 - c) coax cable connection between host and active interface unit
 - d) usually has separate FCC ID; in some cases could be combined/included with host as one enclosure

The following general definitions follow from this stated in the Part 90 rule sections as listed above. Two of the definitions replace previous EAB internal definitions given for booster, repeater and extender. The general term “extender” is the same as booster, but booster should be used rather than extender. The general term “translator” is the same as repeater, but repeater should be used rather than translator.

External radio frequency power amplifier (ERFPA) - any device which, (1) when used in conjunction with a radio transmitter signal source, is capable of amplification of that signal, and (2) is not an integral part of a radio transmitter as manufactured. The EAS equipment class AMP is used only for an ERFPA device inserted between a transmitter

(TNB/PCB) and an antenna (has only one antenna port)

Booster is a device that automatically reradiates signals from base transmitters without channel translation, for the purpose of improving the reliability of existing service by increasing the signal strength in dead spots. An “in-building radiation system” is a signal booster. These devices are not intended to extend the size of coverage from the originating base station. A booster can be either single or multiple channels.

Repeater is a device that retransmits the signals of other stations. Repeaters are different from boosters in that they can include frequency translation and can extend coverage beyond the design of the original base station. A repeater is typically single channel but can also be multiple channels.

ERFPA (AMP) and boosters/repeaters (TNB/PCB) can generally be authorized for all rule parts except 15 and 18.

Tests should be done with each typical signal. e.g., for F3E emissions use 2500 Hz with 2.5 or 5 kHz deviation. Use of CW signal for some tests is acceptable in lieu of actual emission, in some cases when CW signal gives worst case.

The EUT include Host unit, expansion unit and remote unit.

Only remote unit need FCC ID, Host unit and expansion unit do not need separate FCC ID. The EUT belongs to booster(TNB)class.

4.2 TEST PROCEDURE & MEASUREMENT DATA

4.2.1 RF OUTPUT POWER

Test Date:	10 November, 2012
Test Method:	FCC part 2.1046 2-11-04/EAB/RF
Test Requirement:	FCC 27.50 the effective radiated power (ERP) of base transmitters and cellular repeaters must not exceed 100 Watts.
EUT Operation:	The output power of EUT be set to maximum value, the gain of EUT be set to maximum value by software through the manufacture
Conditions:	Normal

Test configuration:

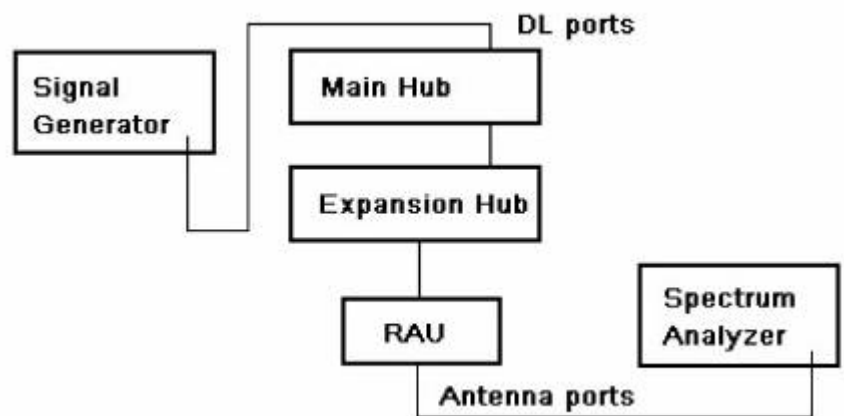

Fig.1 Down Link Configuration

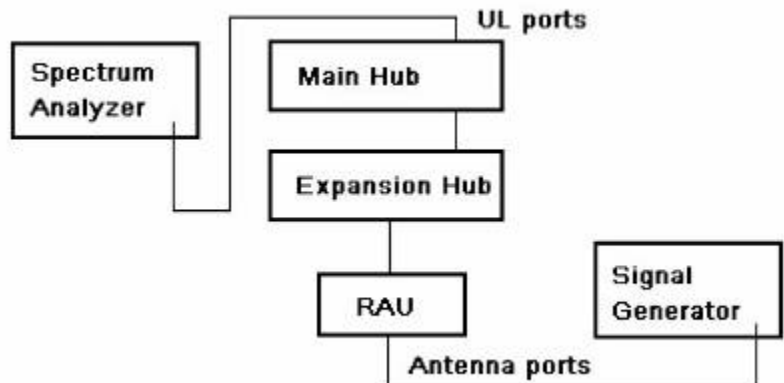

Fig.2 Up Link Configuration

Test Procedure:

RF output power test procedure: **(Conducted measurement)**

- a) Connect the equipment as illustrated, when the output power is over the max value of the Spectrum Analyzer, add the attenuator to avoid destroying the facility.
- b) Set the center frequency of the Spectrum Analyzer to the assigned transmitter frequency, key the transmitter, and set the level of the carrier to the full scale reference line.
- c) Do not apply any tone to modulate the EUT
- d) Adjust the Spectrum Analyzer for the following setting :

FCC ID : NOO-F0699-011

- 1) Resolution Bandwidth \gg the carrier bandwidth
- 2) Video Bandwidth refer to standard requirement
- e) Use spectrum analyzer channel power measurement
- f) Record the frequencies and levels of carrier power
- g) Calculate the signal link way loss and final power value

Remark:**Output power:**

Power on Form 731 should be clearly understood as either composite of multichannels or per carrier, If power is composite Include in comments field: "Power output listed is composite for multi-channel operation."

Check that the input drive level is at the maximum input rating and maximum gain setting for all tests. Check both uplink and downlink input level. See manual or brochures/technical description for maximum rating. May need to check FCC identifier of transmitter used for tests.

Confirm device cannot operate in saturation .Are there means to control maximum power and to assure linear operation (use in system configuration may be necessary) ? How is saturation or over-modulation prevented for pulsed signal inputs?

4.2.1.1 MEASUREMENT RECORD

700MHz Band:

Frequency Band (728MHz-746MHz),Measure Max Out put power (dBm)	
LTE(1.4MHz)	
728.70 MHz	17.92
737.00 MHz	17.94
745.30 MHz	17.95
Max value in W	
0.062	
LTE(3MHz)	
729.50 MHz	17.94
737.00 MHz	17.96
744.50 MHz	17.97
Max value in W	
0.063	
LTE(5MHz)	
730.50 MHz	17.93
737.00 MHz	17.95
743.50 MHz	17.97
Max value in W	
0.063	
LTE(10MHz)	
733.00 MHz	17.93
737.00 MHz	17.95
741.00 MHz	17.92
Max value in W	
0.062	
LTE(15MHz)	
735.50 MHz	17.94
737.00 MHz	17.96
738.50 MHz	17.95
Max value in W	
0.062	

2100MHz Band:

Frequency Band (2110MHz-2155MHz),Measure Max Out put power (dBm)	
LTE(1.4MHz)	
2110.70 MHz	22.89
2132.50 MHz	22.91
2154.30 MHz	22.93
Max value in W	
0.196	
LTE(3MHz)	
2111.50 MHz	22.92
2132.50 MHz	22.94
2153.50 MHz	22.95
Max value in W	
0.197	
LTE(5MHz)	
2112.50 MHz	22.90
2132.50 MHz	22.93
2152.50 MHz	22.96
Max value in W	
0.198	
LTE(10MHz)	
2115.00 MHz	22.94
2132.50 MHz	22.97
2150.00 MHz	22.93
Max value in W	
0.198	
LTE(15MHz)	
2117.50 MHz	22.92
2132.50 MHz	22.94
2147.50 MHz	22.96
Max value in W	
0.198	

2100MHz Band:

Frequency Band (2110MHz-2155MHz),Measure Max Out put power (dBm)	
WCDMA	
2112.5 MHz	22.94
2132.5 MHz	22.98
2152.5 MHz	22.92
Max value in W	
0.199	

Remark: test in single channel status, output power is test in full amplifying status

4.2.2 CONDUCTED SPURIOUS EMISSIONS

Test Date: 10 November, 2012
 Test Method: FCC part 2.1051

Test Requirement: FCC 27.53 The power of any emission outside of the authorized operating frequency ranges must be attenuated below the transmitting power (P) by a factor of at least $43 + 10\log(P)$ dB, or -13dBm.

EUT Operation: The output power of EUT be set to maximum value ,the gain of EUT be set to maximum value by software through the manufacture

Conditions Normal

Test configuration

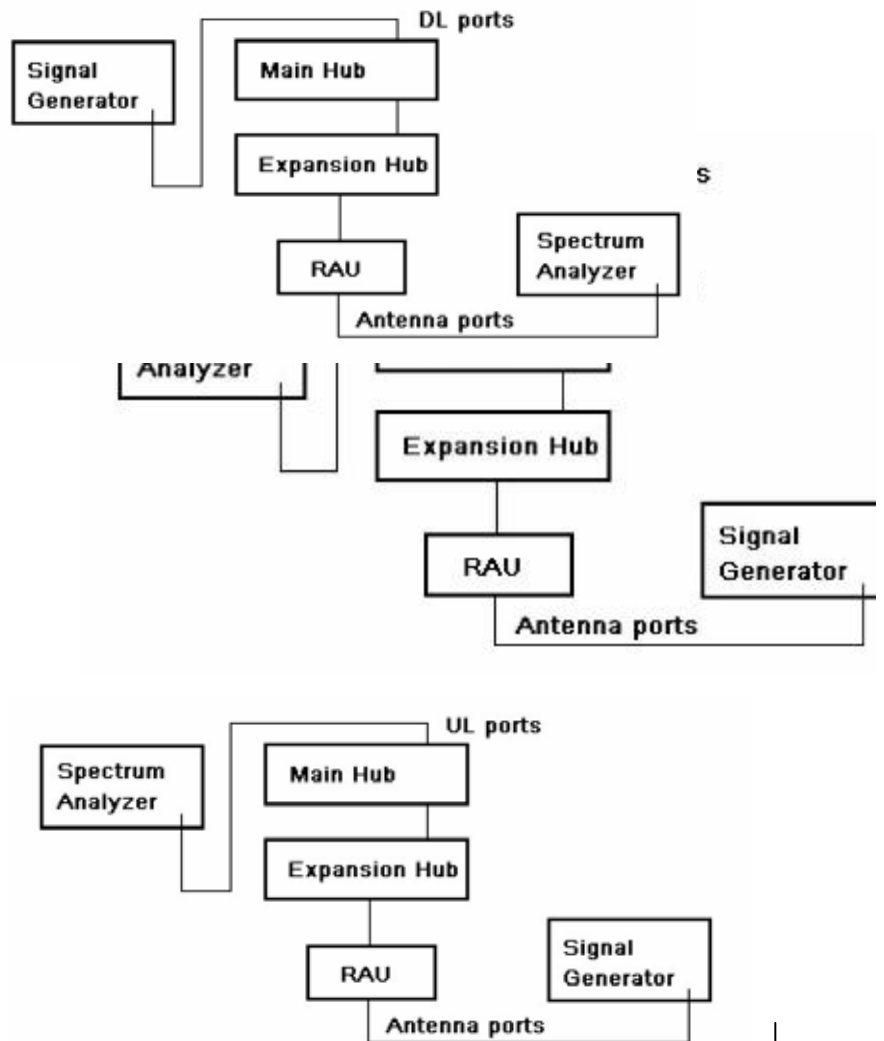
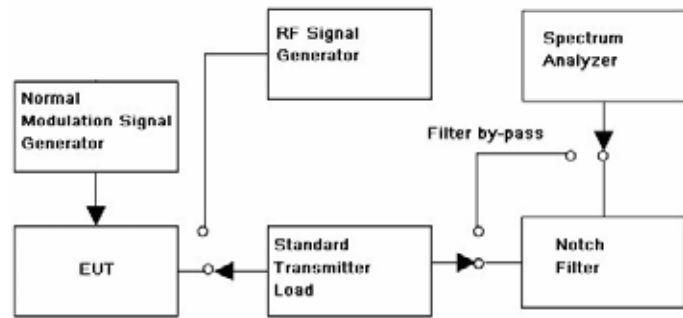

Fig.2 Up Link Configuration

Test Procedure:



Conducted Emission test procedure:

- a) Connect the equipment as illustrated, when the output power is over the max value of the Spectrum Analyzer, add the attenuator to avoid destroying the facility.
- b) Set the center frequency of the Spectrum Analyzer to the assigned transmitter frequency, key the transmitter, and set the level of the carrier to the full scale reference line.
- c) Do not apply any tone to modulate the EUT
- d) Adjust the Spectrum Analyzer for the following setting :
 - 1) Resolution Bandwidth, (base the standard, apply the different set). here is 100KHZ for frequency band less than 1GHZ, 1MHz for frequency over 1GHZ;
 - 2) Video Bandwidth refer to standard requirement
- e) Adjust the center frequency of the spectrum analyzer for incremental coverage of the range from:
 - 1) the lowest radio frequency generated in the equipment, it can be 9KHZ base the test method, here select 30MHz as lowest frequency start point;
 - 2) the highest radio frequency shall higher than 10 times of carrier frequency.
- f) Record the frequencies and levels of carrier power

Remark

The notch filter is used for avoid the EUT fundamental carrier output power making the spectrum overload and the harmonic spurious brought it.

When the EUT fundamental carrier is not enough to make the status ,the notch filter could be not used.

4.2.2.1 MEASUREMENT RECORD

700MHz Band

700MHz-LTE-1.4M downlink (lowest frequency) 30MHz-1GHz

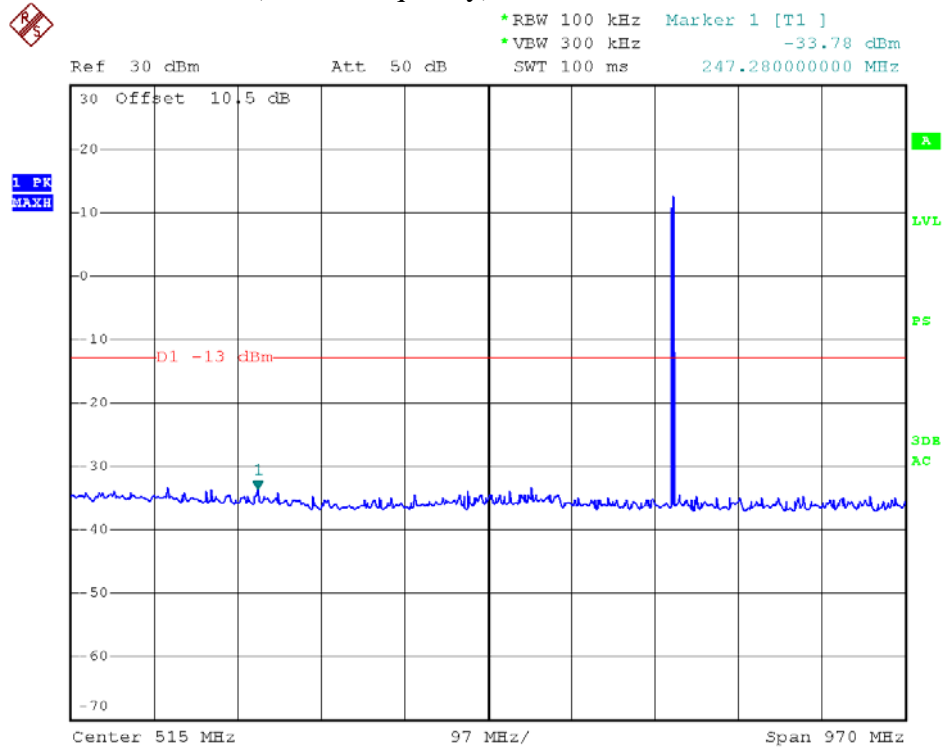

700MHz -LTE-1.4M downlink (lowest frequency) Above 1GHz

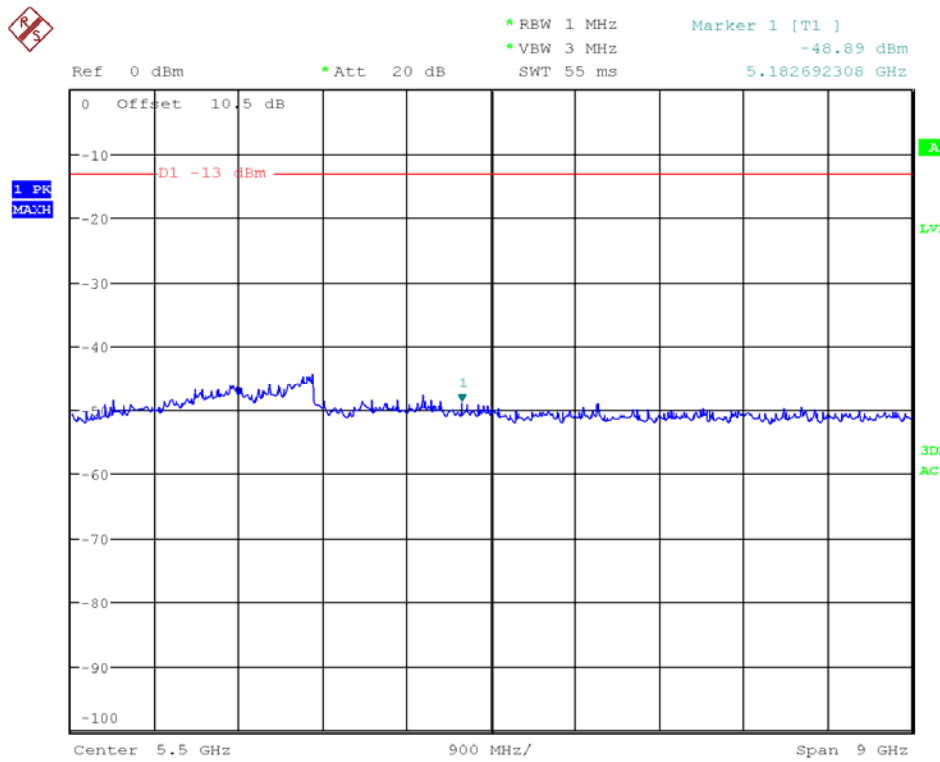

700MHz -LTE-1.4M downlink (middle frequency) 30MHz-1GHz

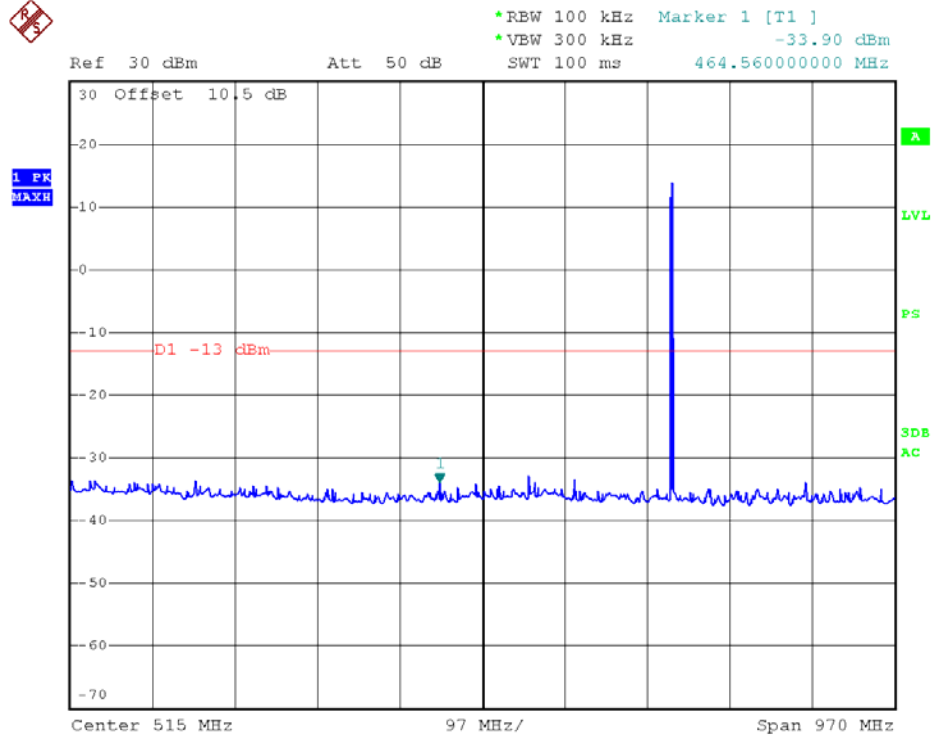

700MHz -LTE-1.4M downlink (middle frequency) Above 1GHz

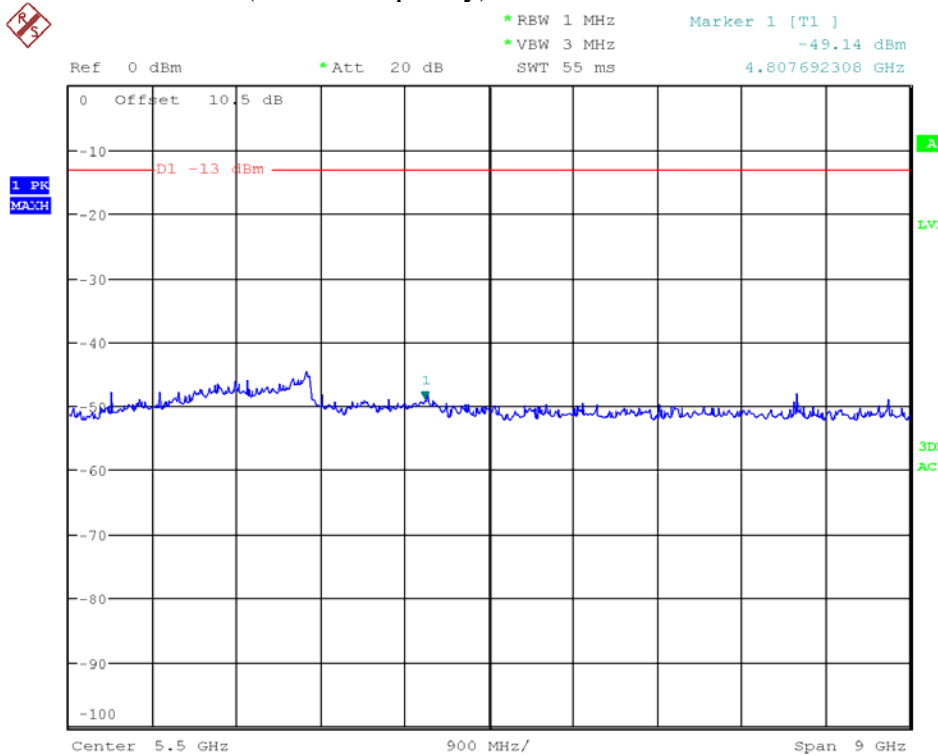

700MHz -LTE-1.4M downlink (highest frequency) 30MHz-1GHz

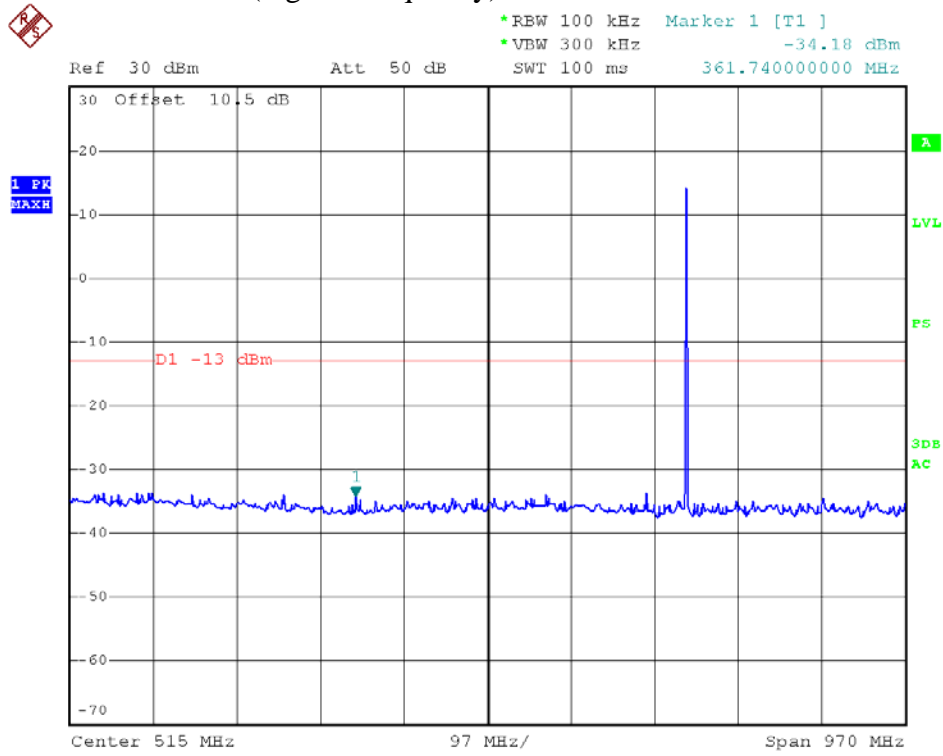

700MHz -LTE-1.4M downlink (highest frequency) Above 1GHz

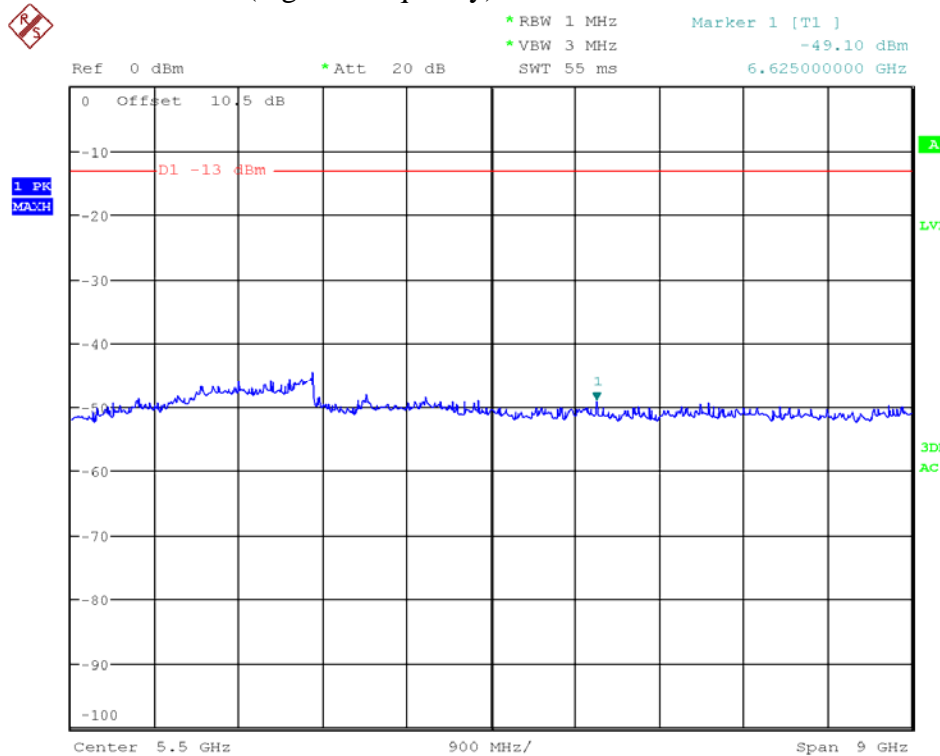

700MHz -LTE-1.4M uplink (lowest frequency) 30MHz-1GHz

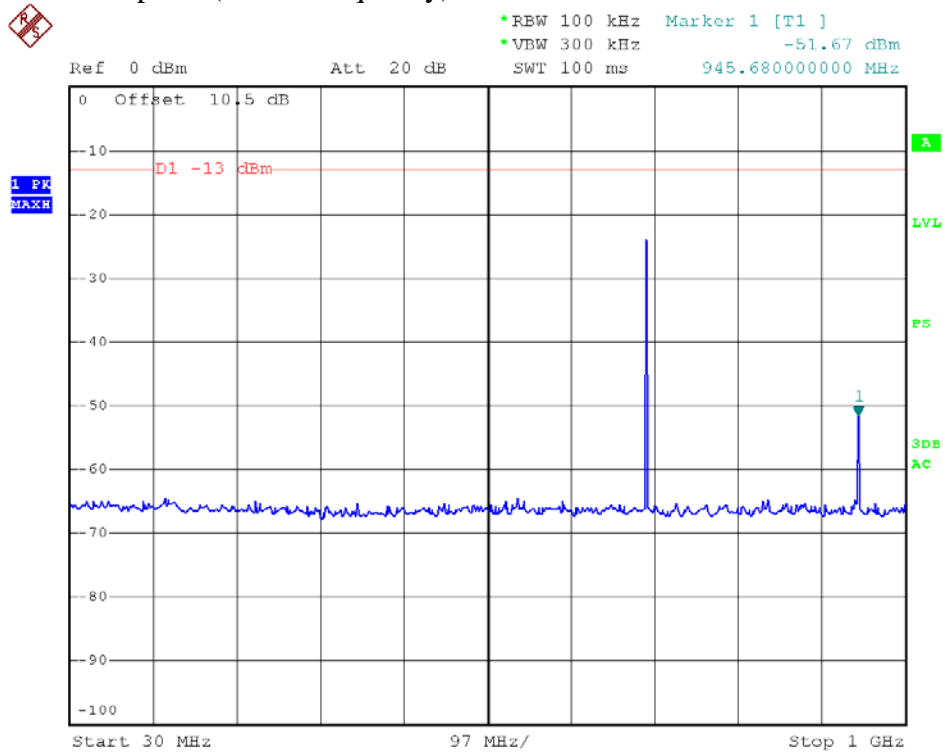

700MHz -LTE-1.4M uplink (lowest frequency) Above 1GHz

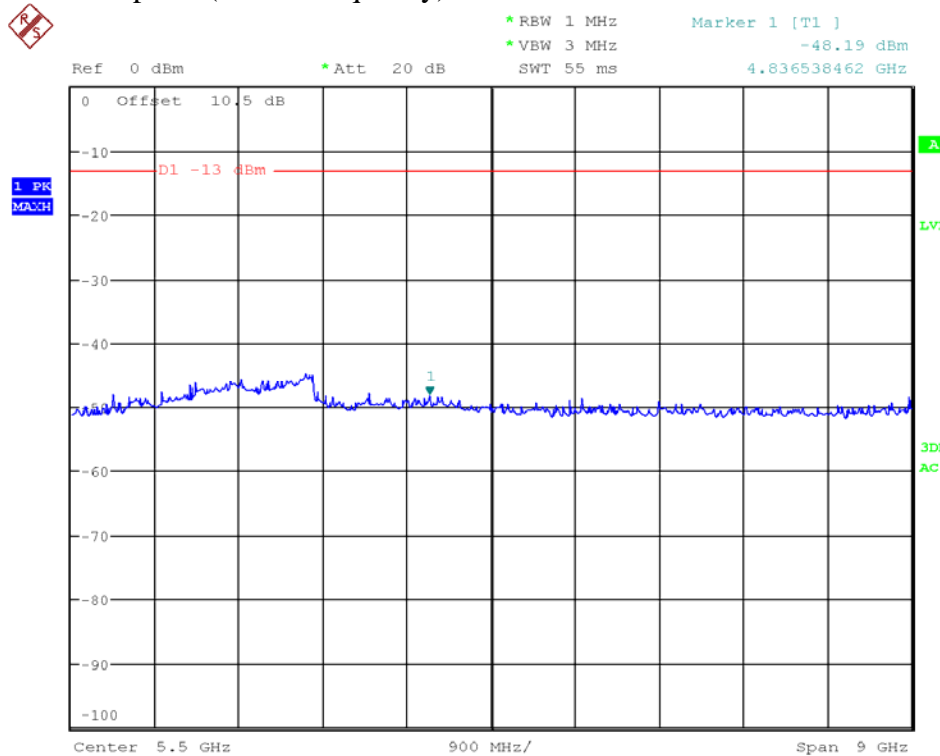

700MHz -LTE-1.4M uplink (middle frequency) 30MHz-1GHz

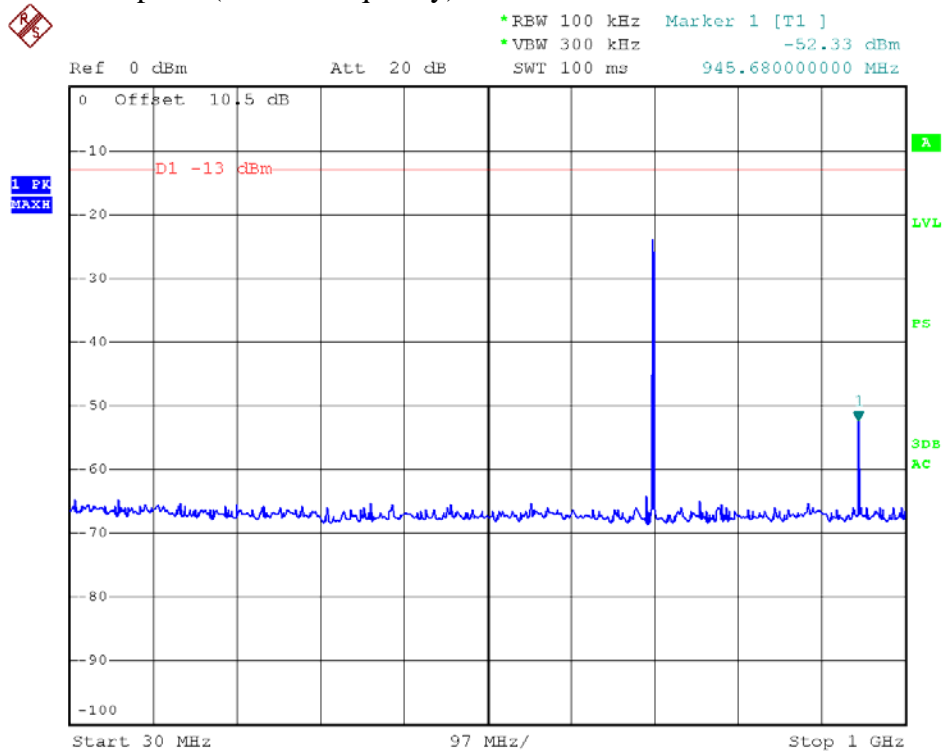

700MHz -LTE-1.4M uplink(middle frequency) Above 1GHz

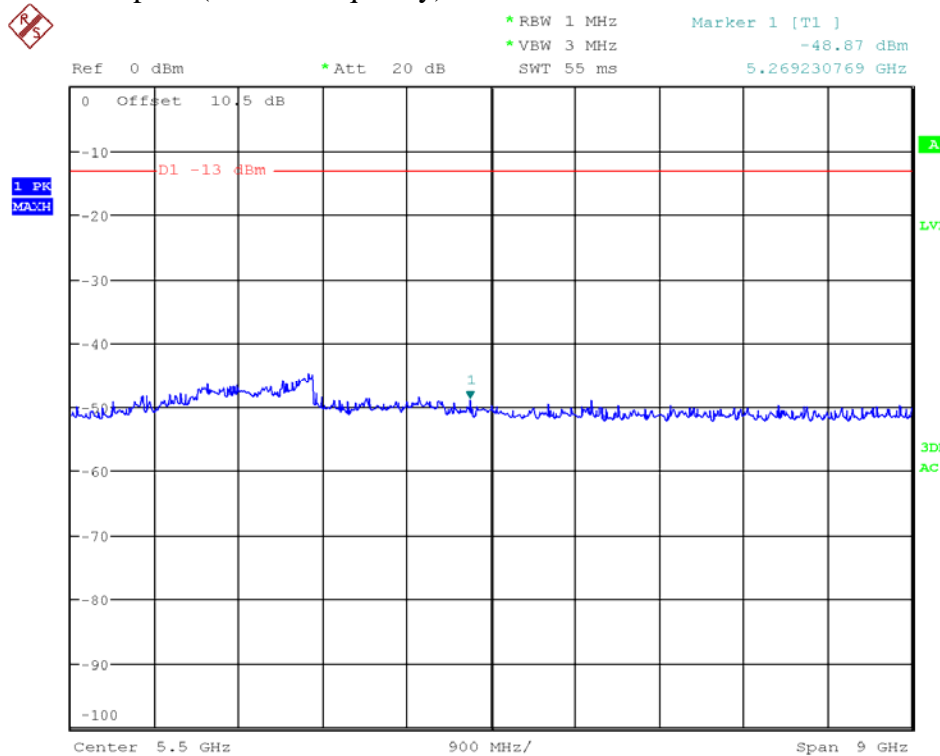

700MHz -LTE-1.4M uplink (highest frequency) 30MHz-1GHz

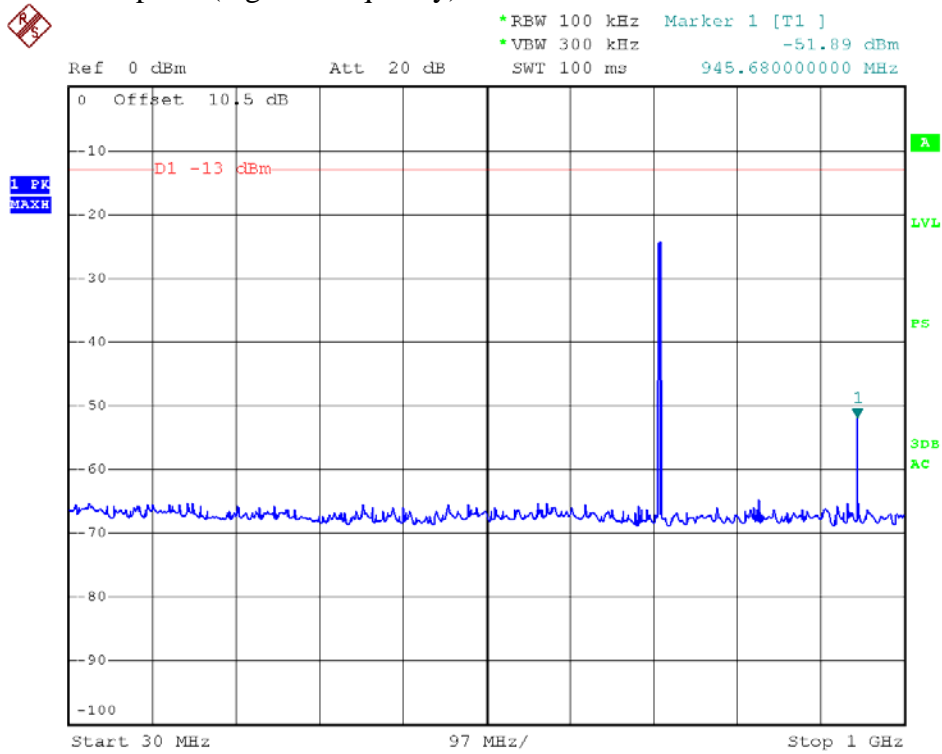

700MHz -LTE-1.4M uplink (highest frequency) Above 1GHz

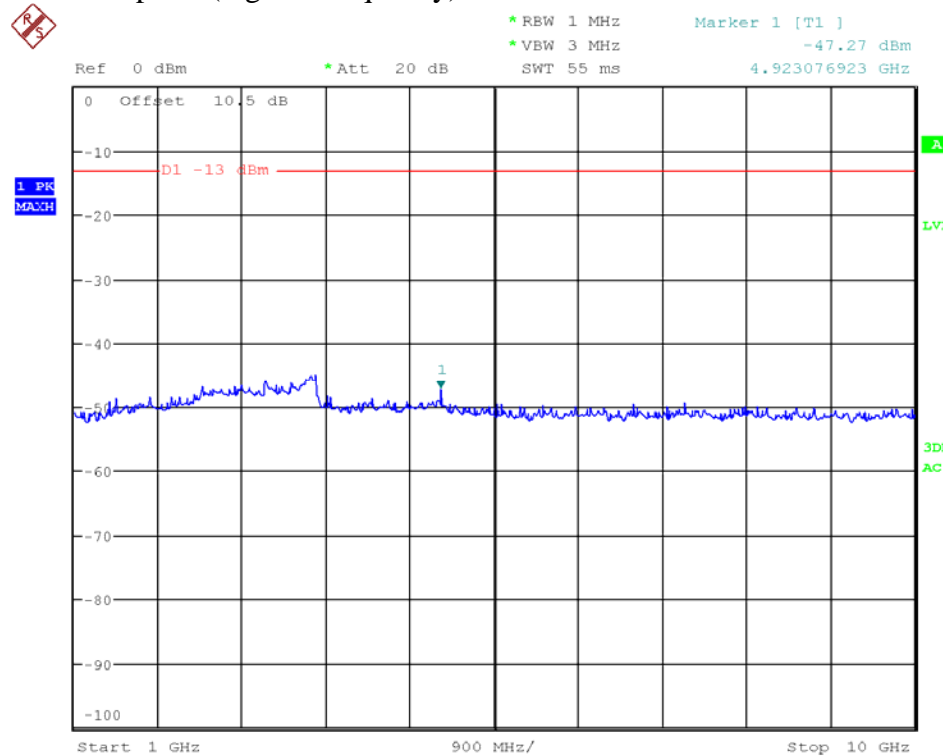

700MHz-LTE-3M downlink (lowest frequency) 30MHz-1GHz

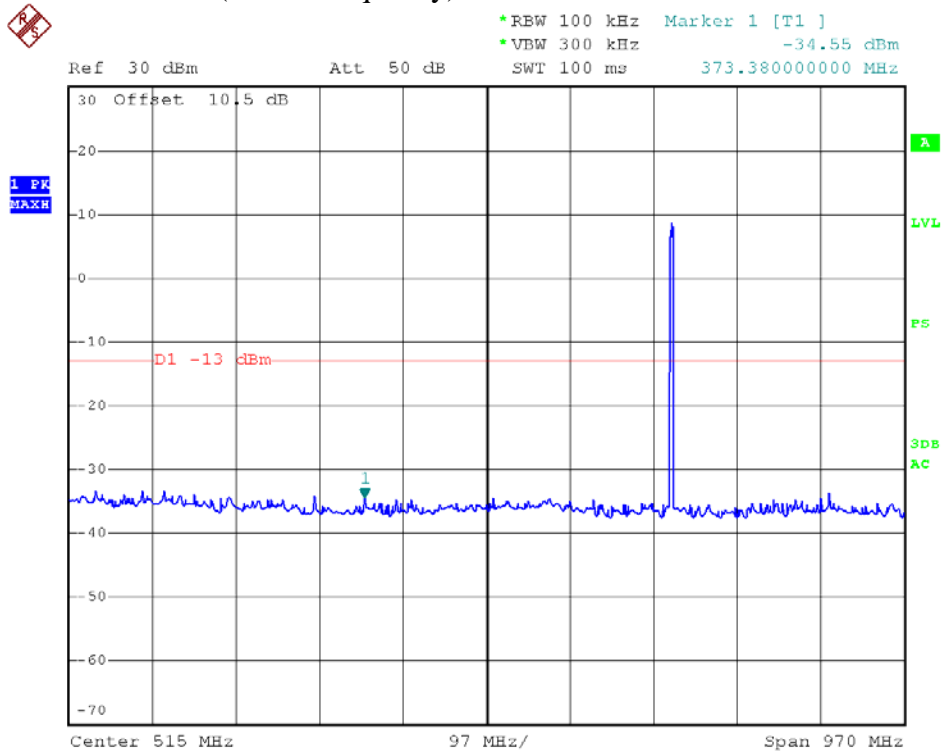

700MHz -LTE-3M downlink (lowest frequency) Above 1GHz

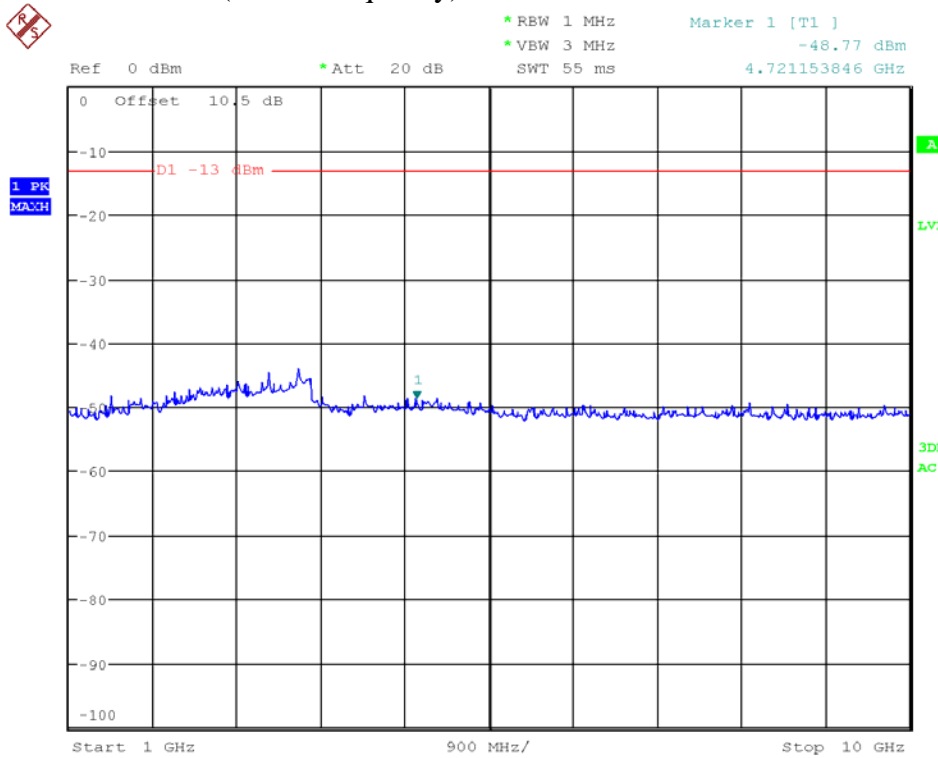

700MHz -LTE-3M downlink (middle frequency) 30MHz-1GHz

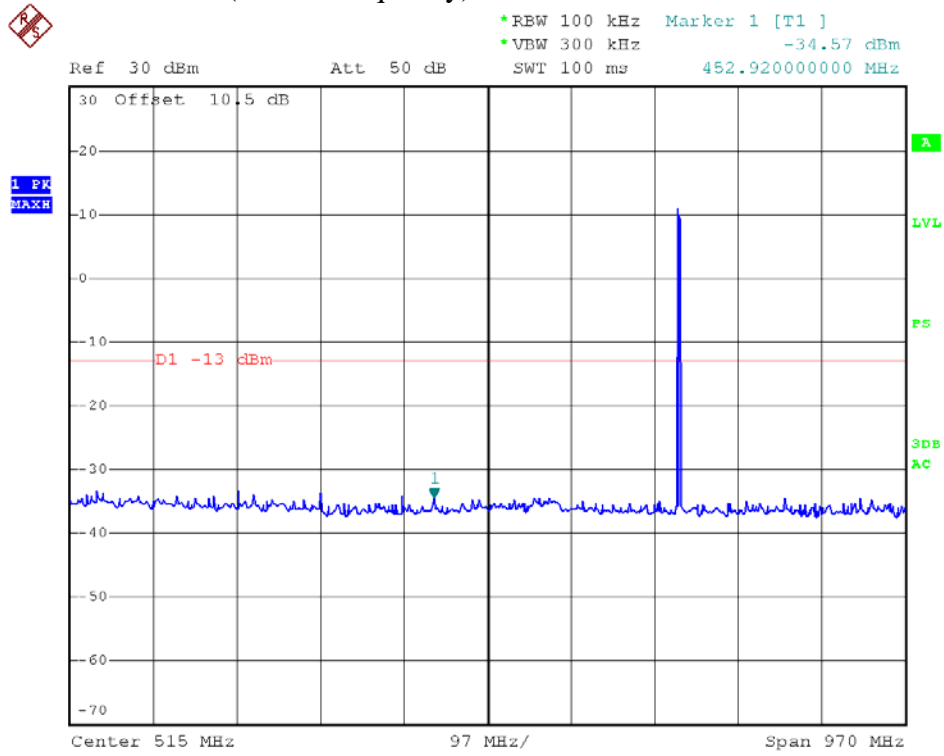

700MHz -LTE-3M downlink (middle frequency) Above 1GHz

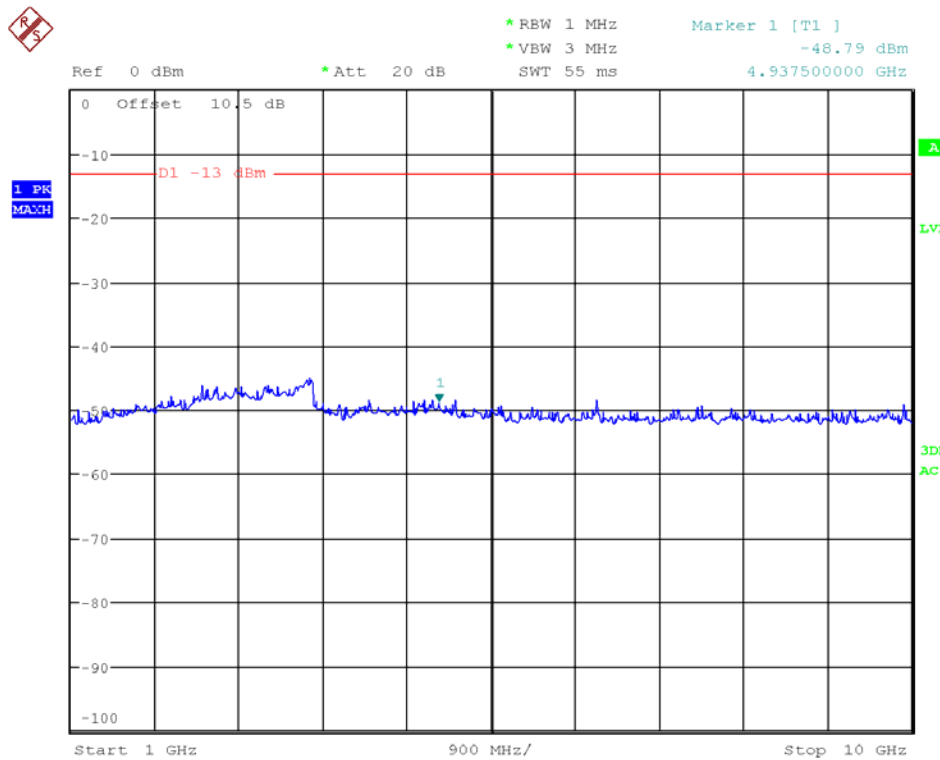

700MHz -LTE-3M downlink (highest frequency) 30MHz-1GHz

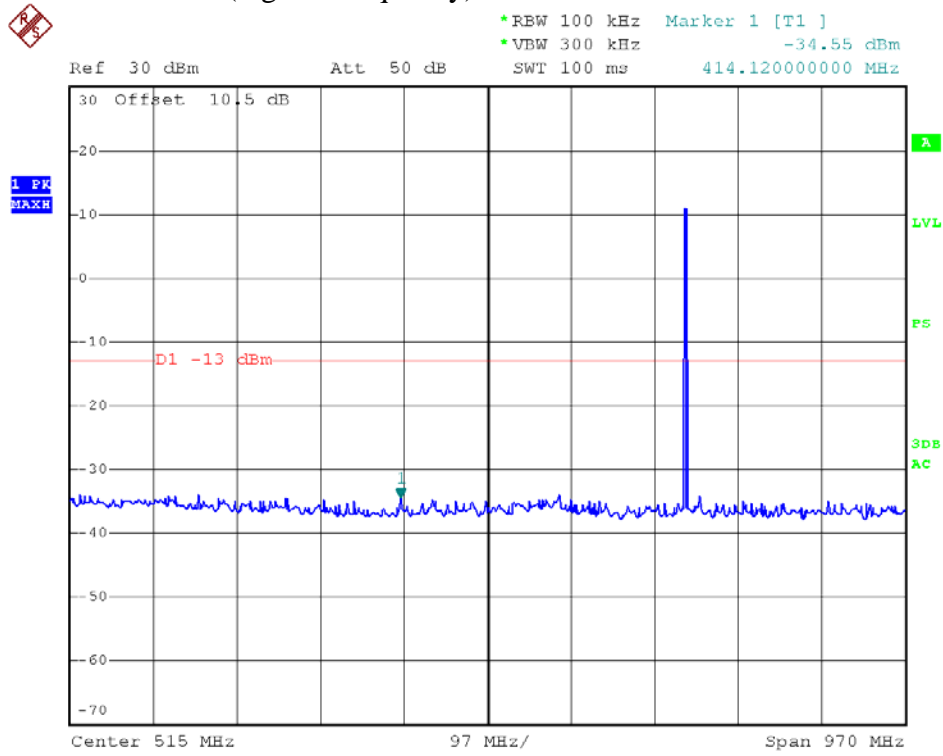

700MHz -LTE-3M downlink (highest frequency) Above 1GHz

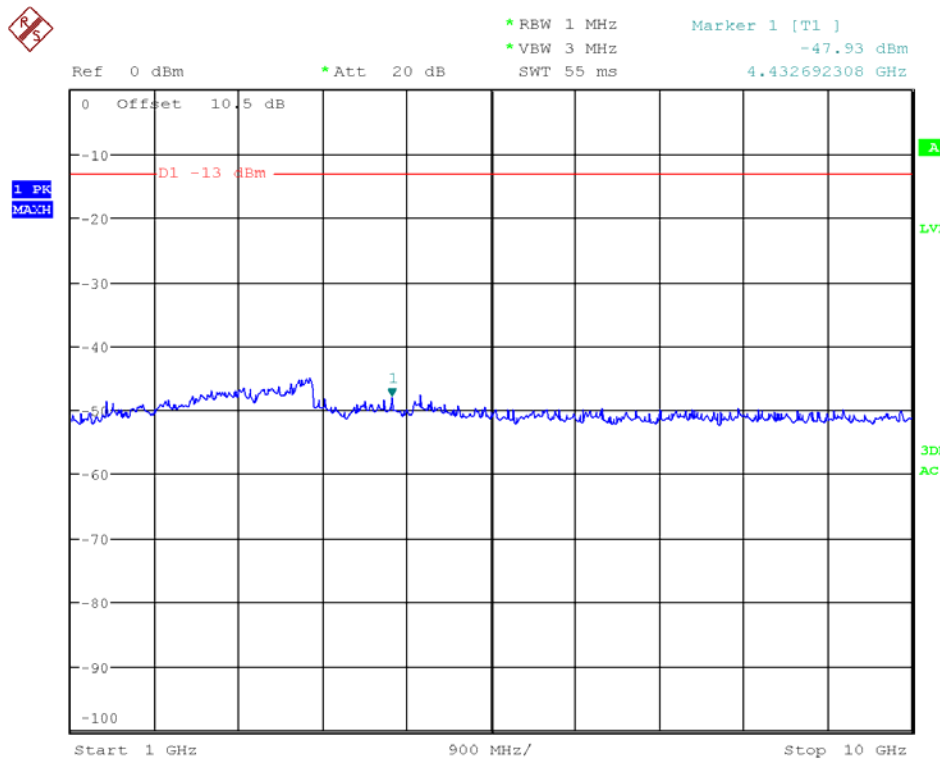

700MHz -LTE-3M uplink (lowest frequency) 30MHz-1GHz

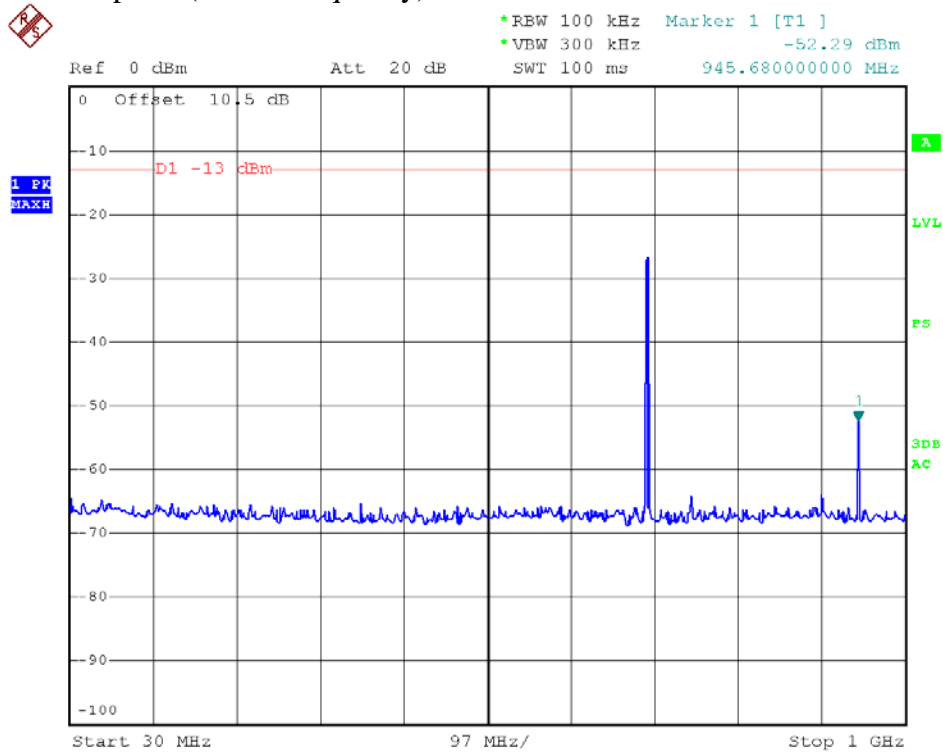

700MHz -LTE-3M uplink (lowest frequency) Above 1GHz

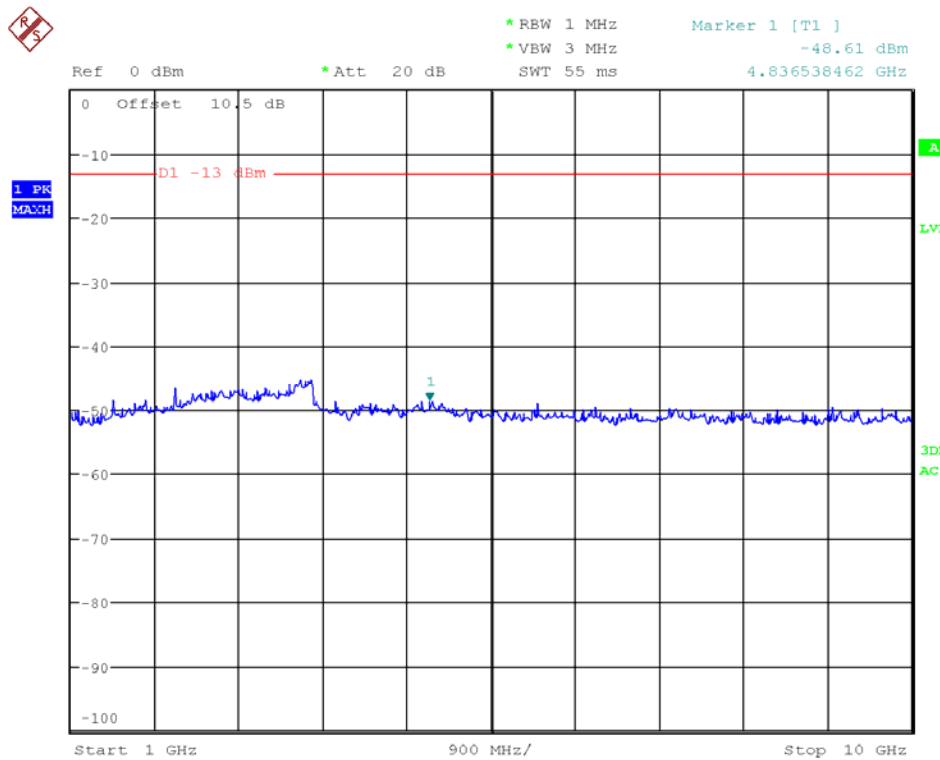

700MHz -LTE-3M uplink (middle frequency) 30MHz-1GHz

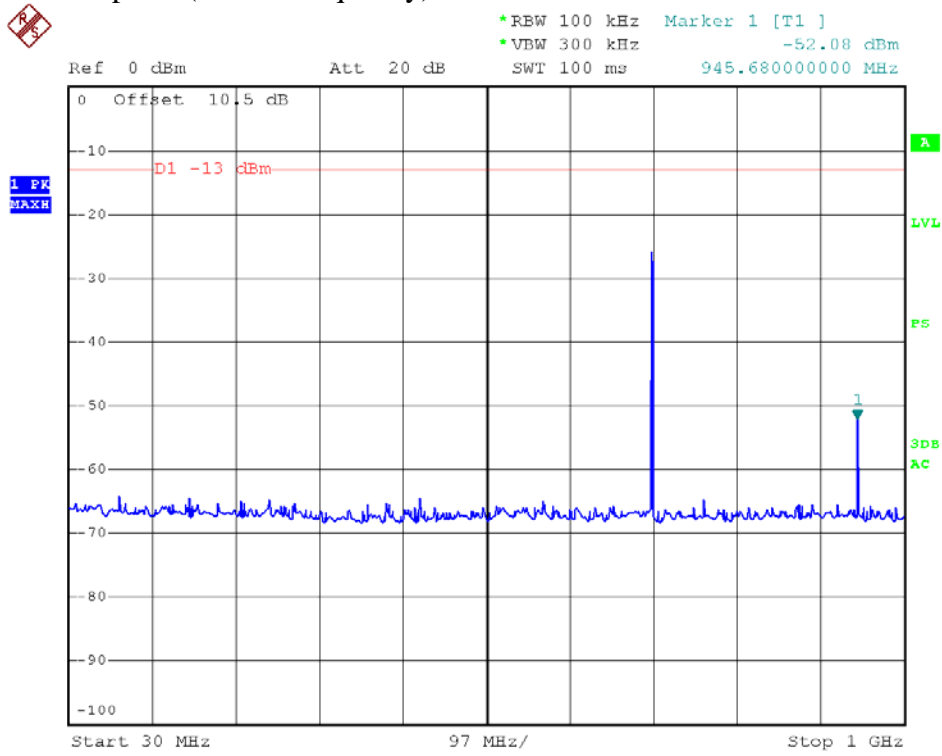

700MHz -LTE-3M uplink(middle frequency) Above 1GHz

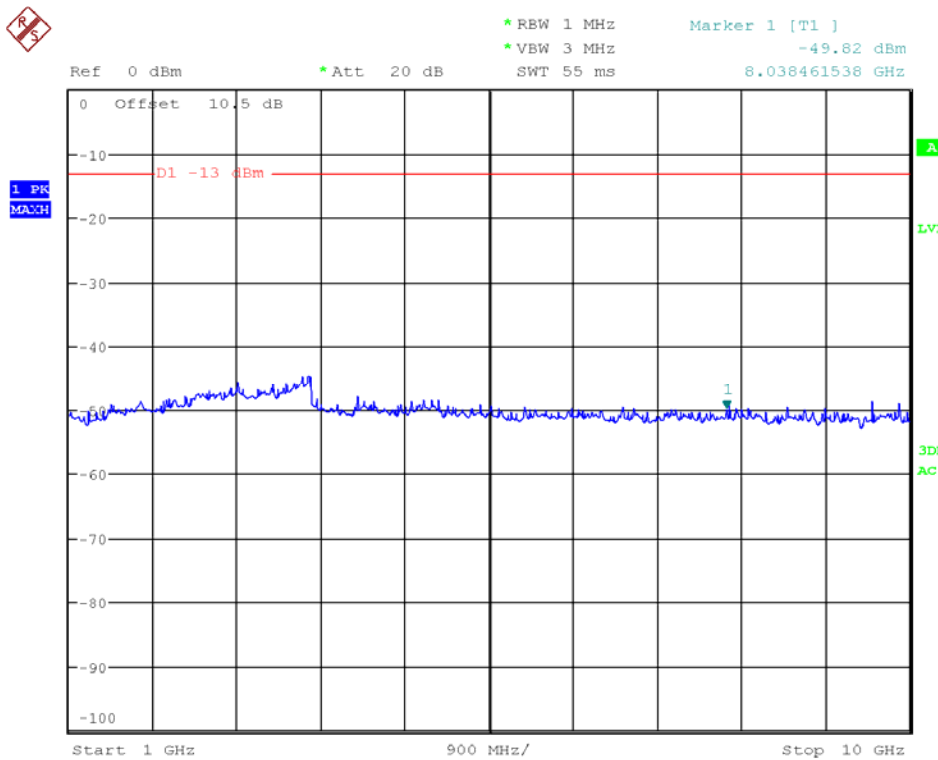

700MHz -LTE-3M uplink (highest frequency) 30MHz-1GHz

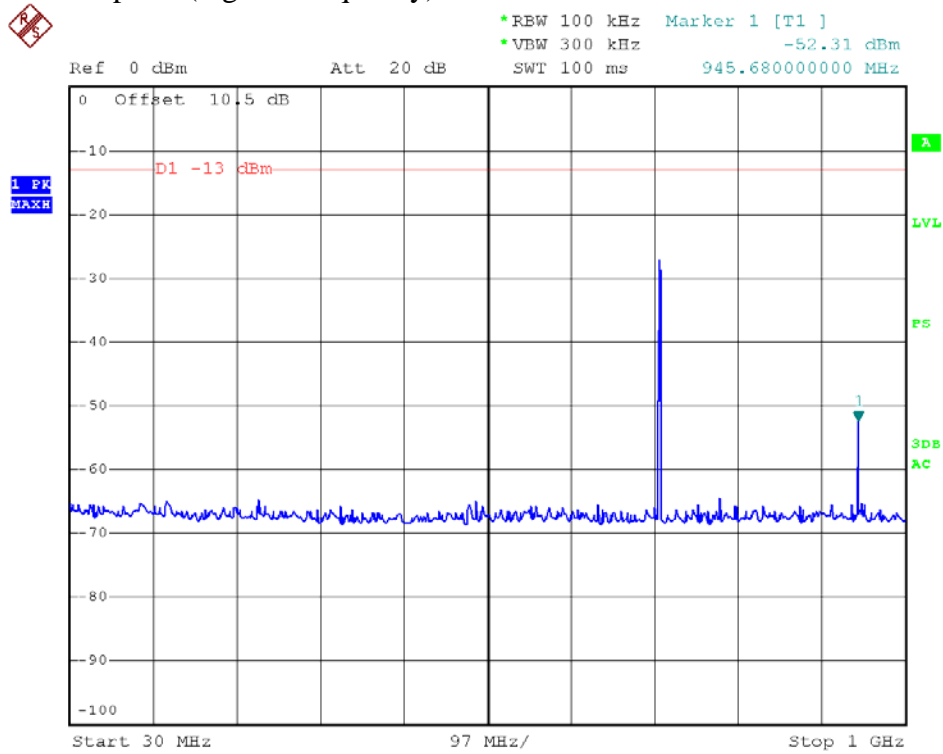

700MHz -LTE-3M uplink (highest frequency) Above 1GHz

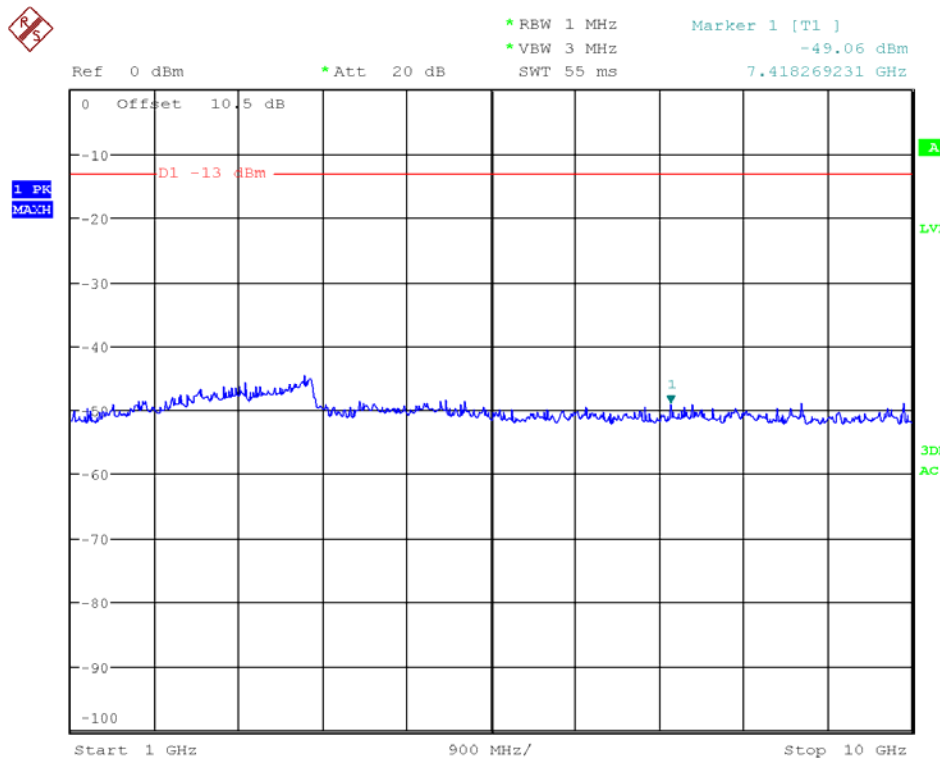

700MHz-LTE-5M downlink (lowest frequency) 30MHz-1GHz

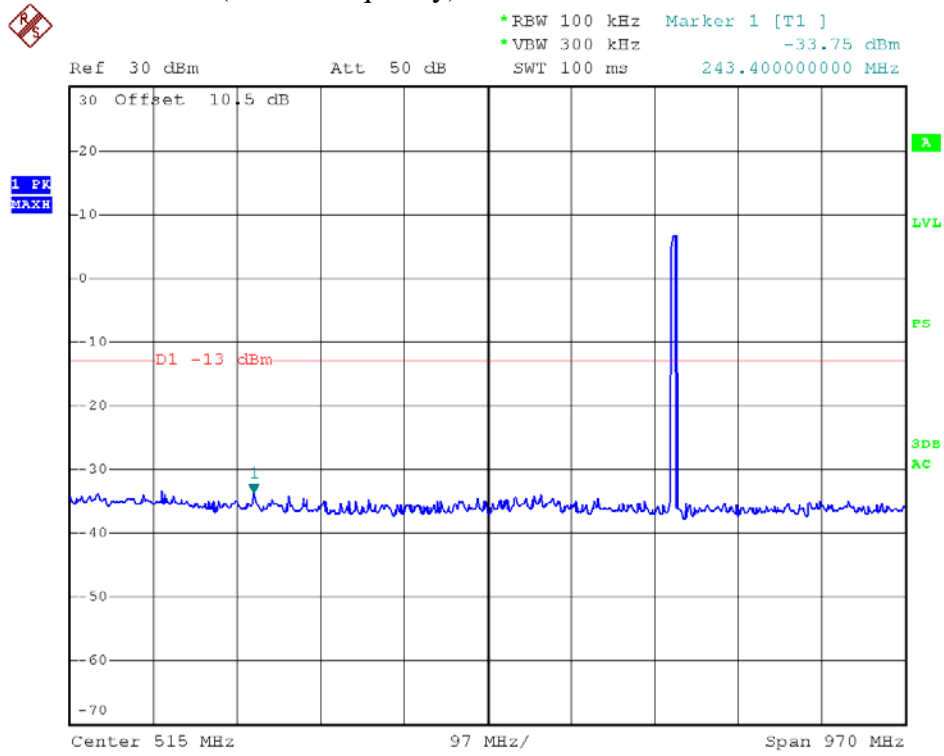

700MHz -LTE-5M downlink (lowest frequency) Above 1GHz

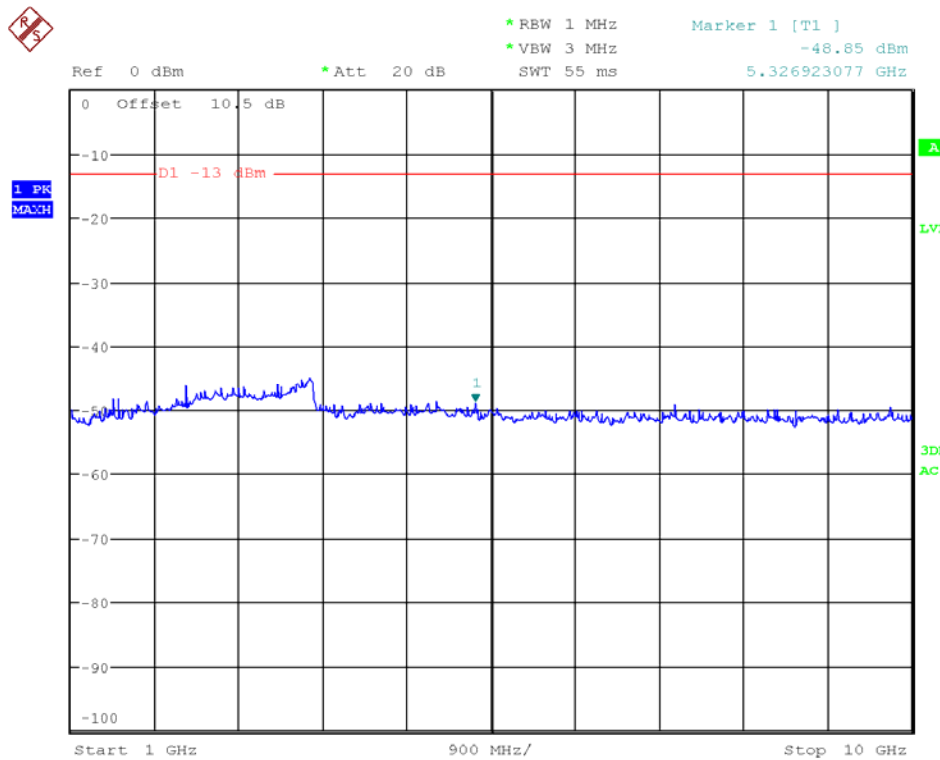

700MHz -LTE-5M downlink (middle frequency) 30MHz-1GHz

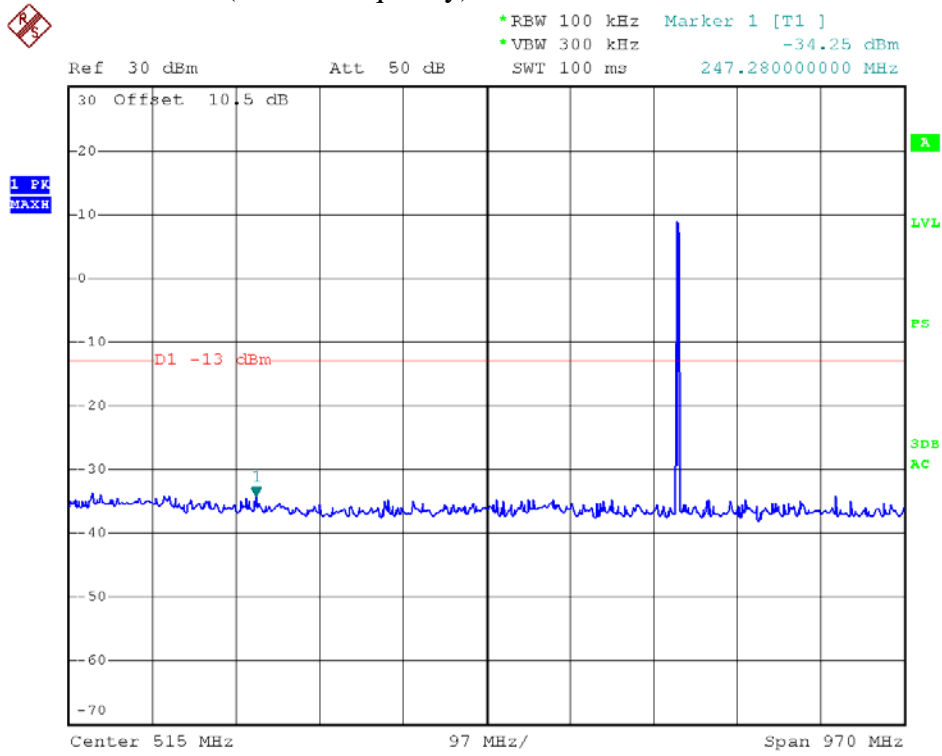

700MHz -LTE-5M downlink (middle frequency) Above 1GHz

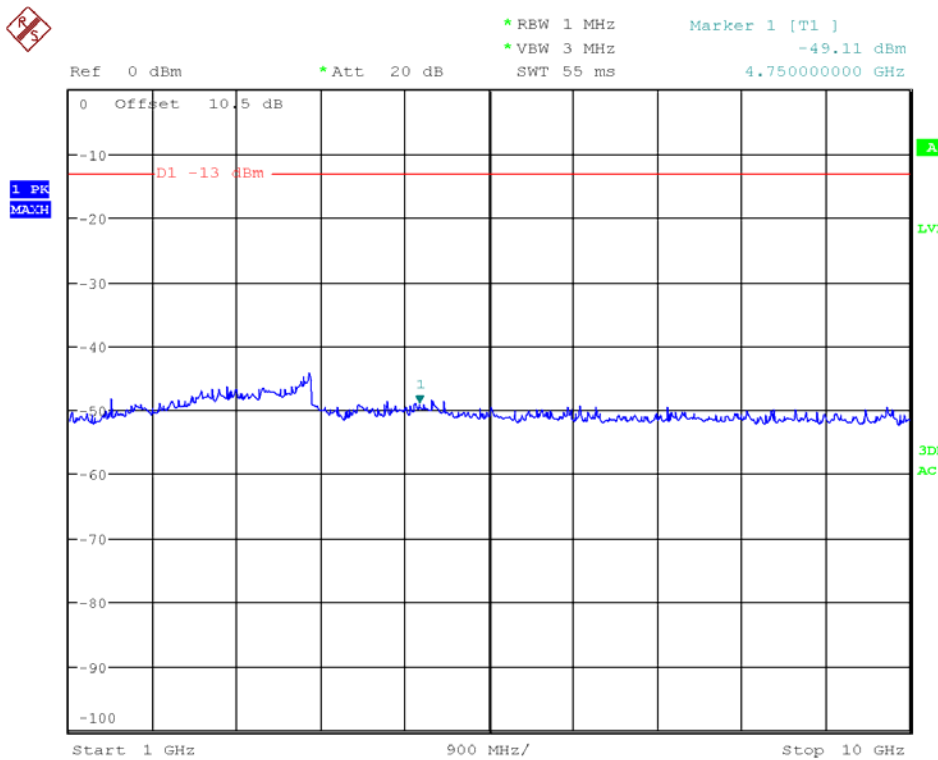

700MHz -LTE-5M downlink (highest frequency) 30MHz-1GHz

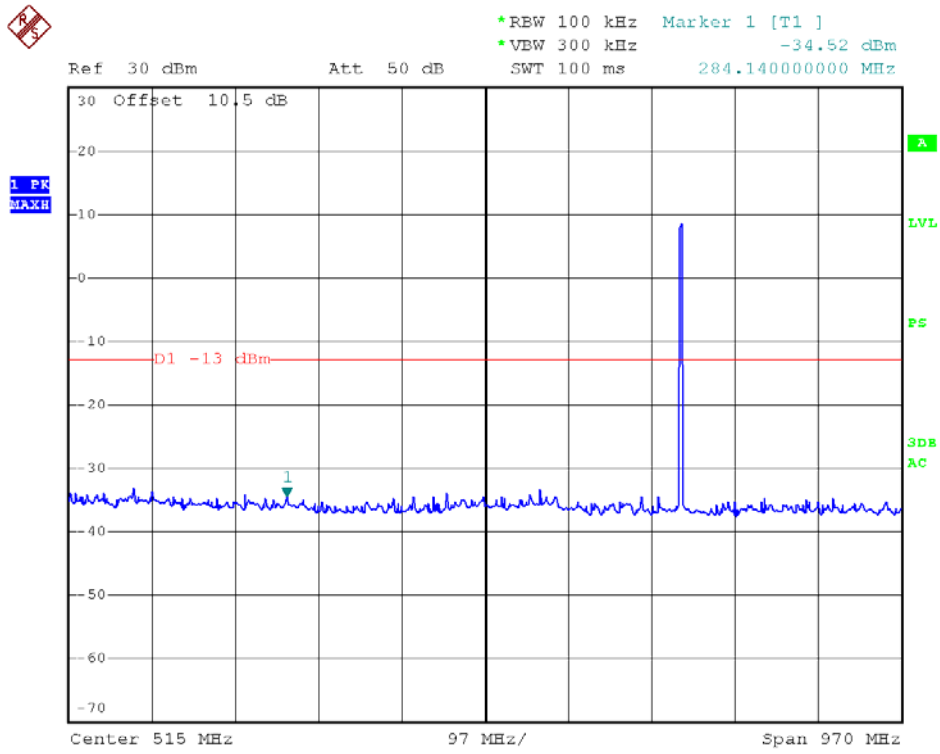

700MHz -LTE-5M downlink (highest frequency) Above 1GHz

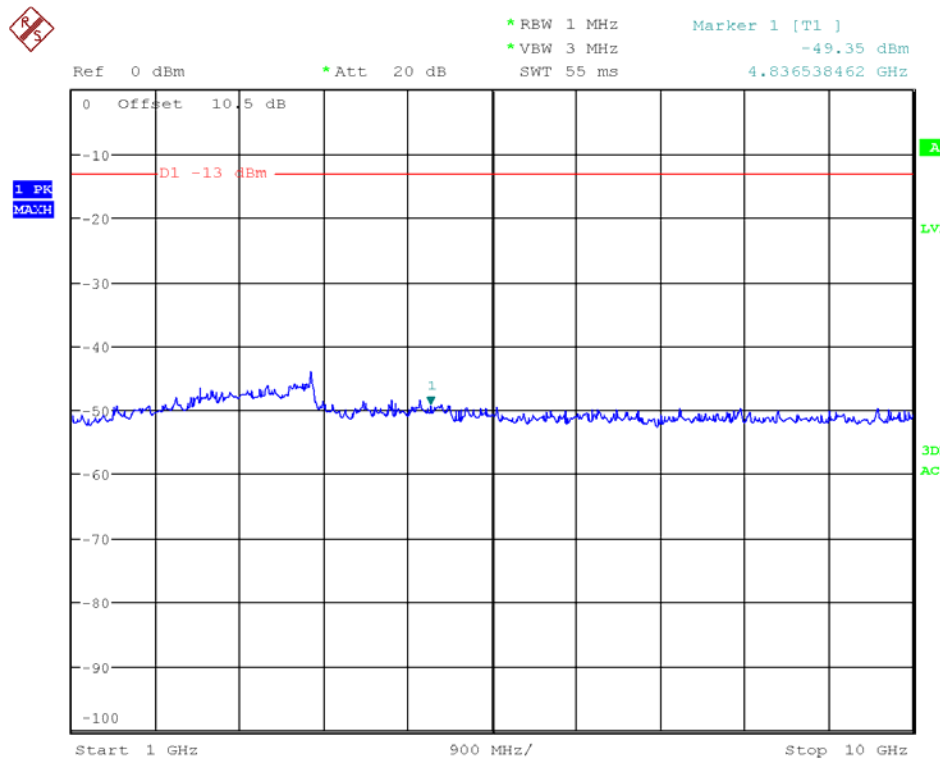

700MHz -LTE-5M uplink (lowest frequency) 30MHz-1GHz

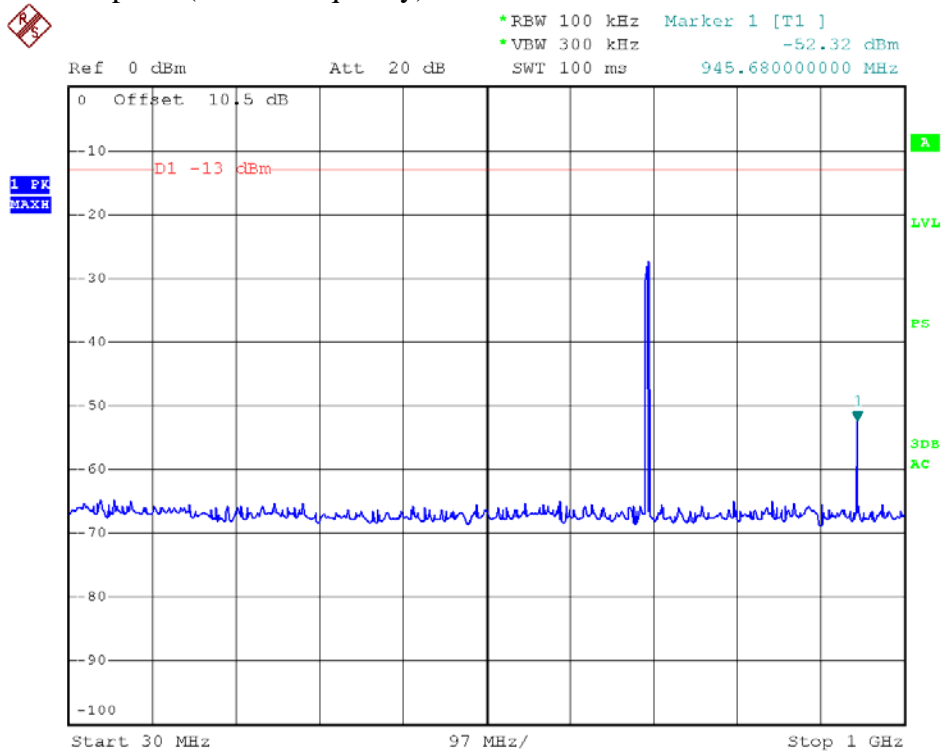

700MHz -LTE-5M uplink (lowest frequency) Above 1GHz

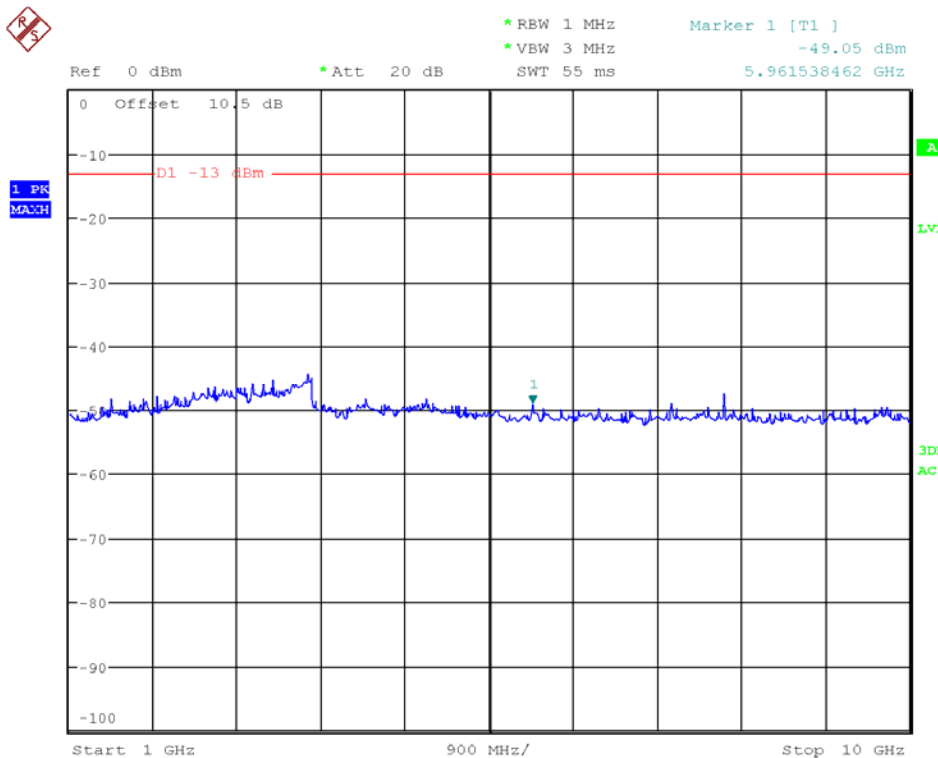

700MHz -LTE-5M uplink (middle frequency) 30MHz-1GHz

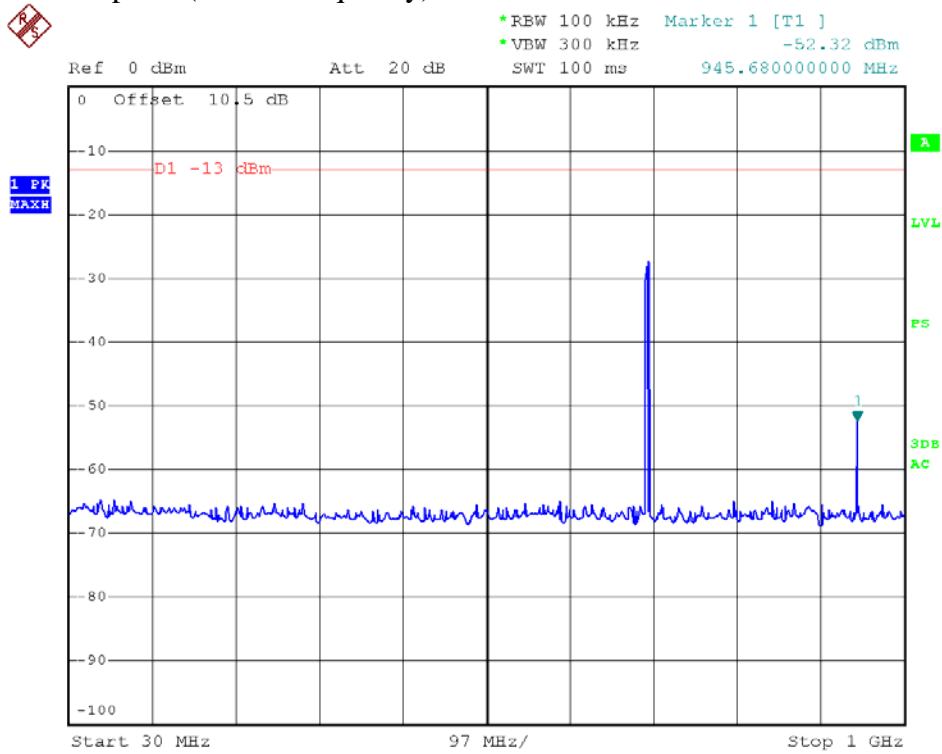

700MHz -LTE-5M uplink(middle frequency) Above 1GHz

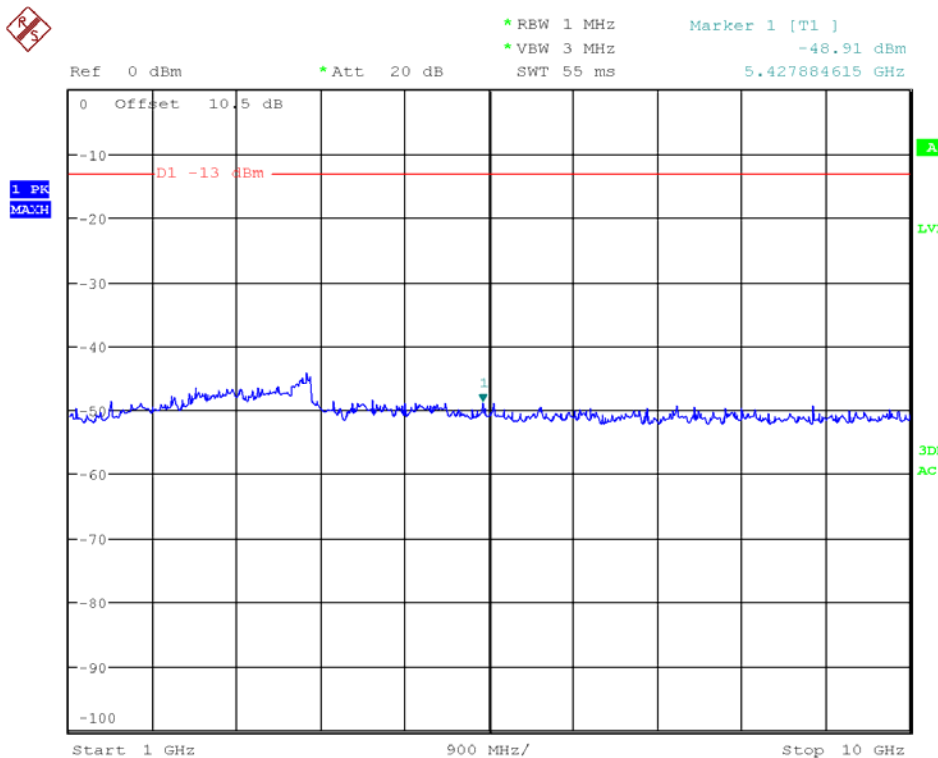

700MHz -LTE-5M uplink (highest frequency) 30MHz-1GHz

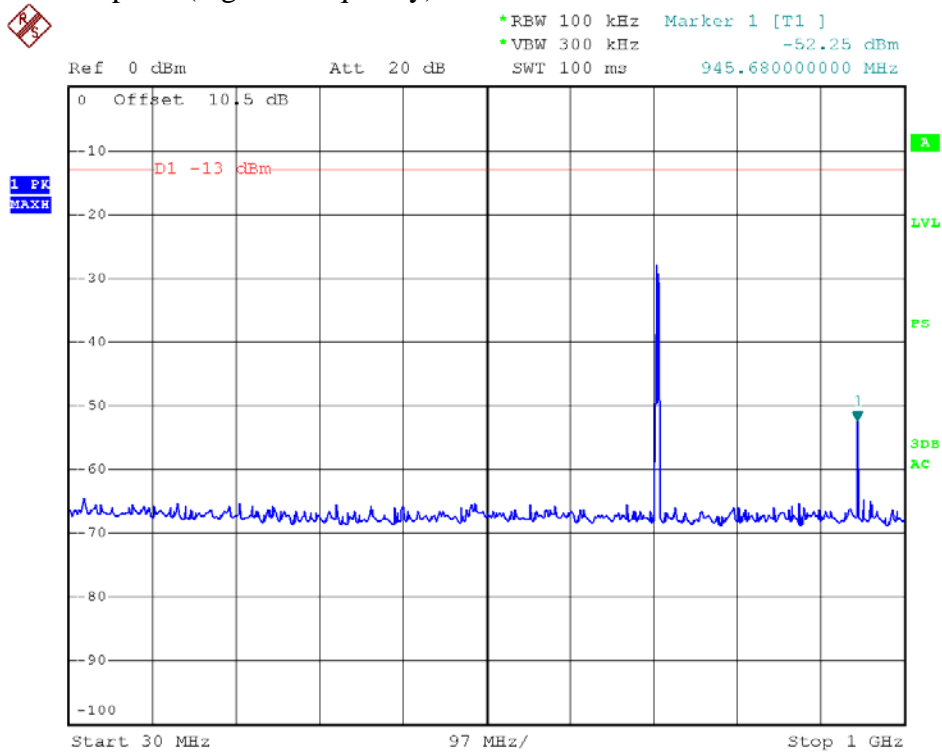

700MHz -LTE-5M uplink (highest frequency) Above 1GHz

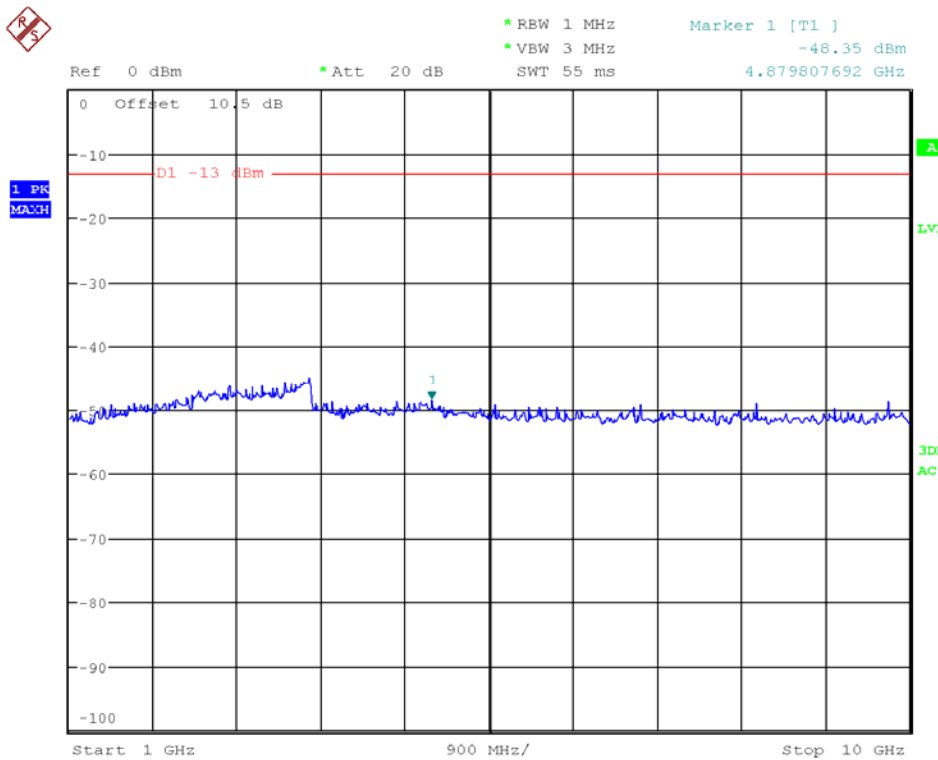

700MHz -LTE-10M downlink (lowest frequency) 30MHz-1GHz

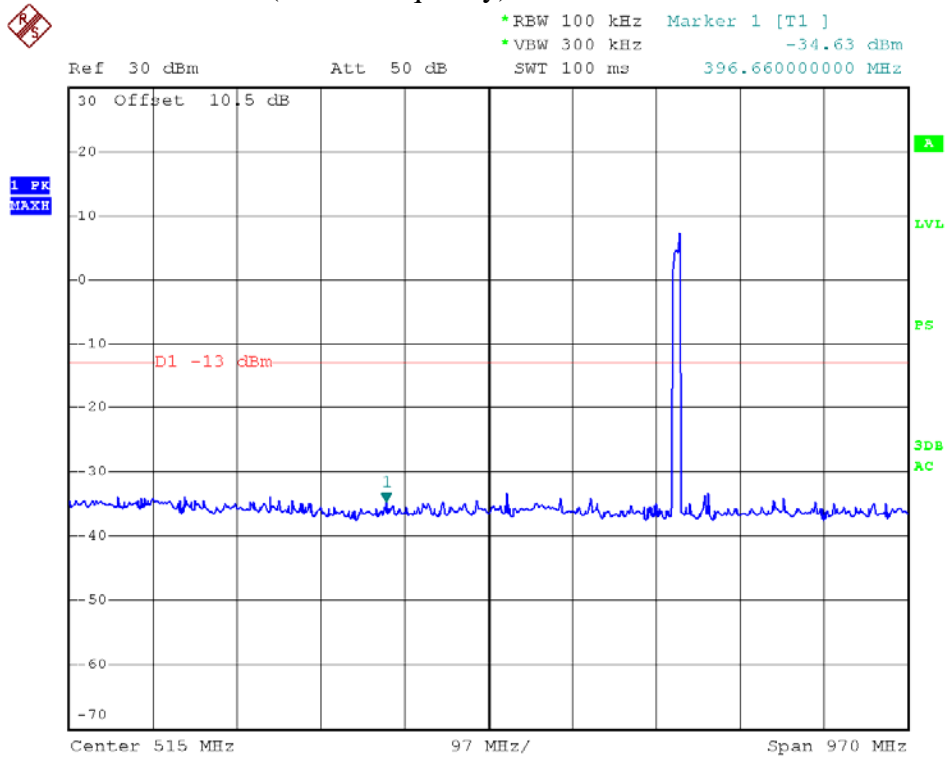

700MHz -LTE-10M downlink (lowest frequency) Above 1GHz

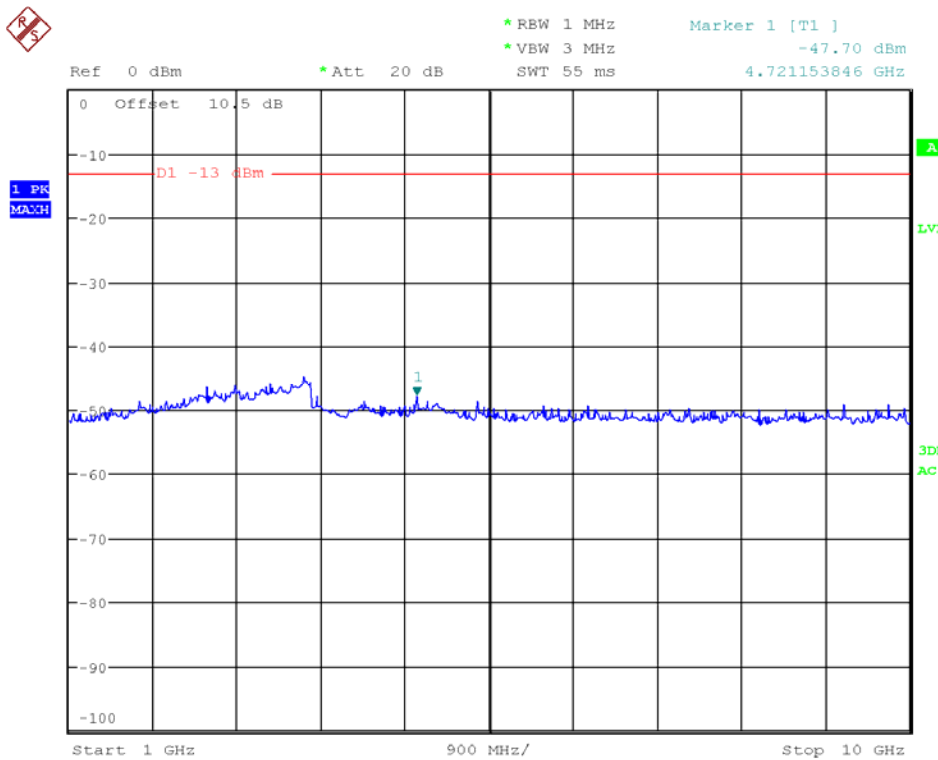

700MHz -LTE-10M downlink (middle frequency) 30MHz-1GHz

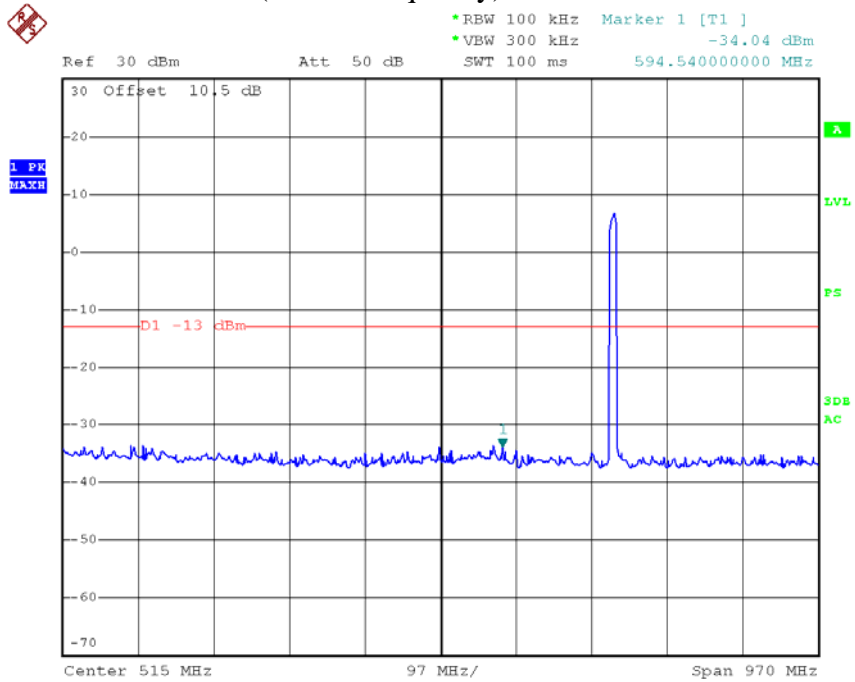

700MHz -LTE-10M downlink (middle frequency) Above 1GHz

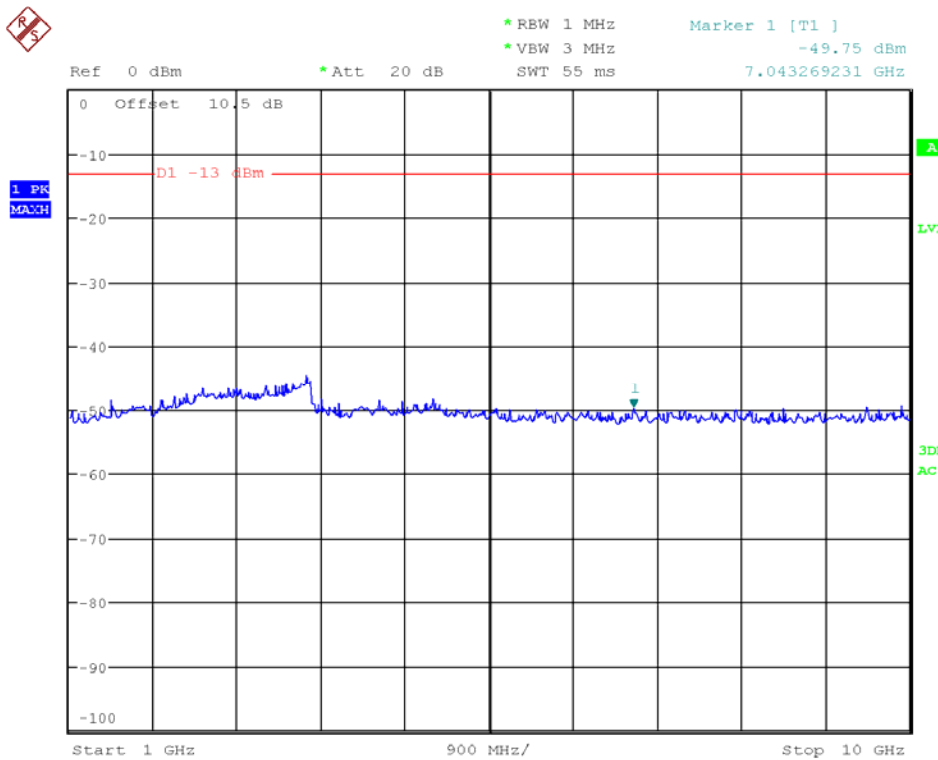

700MHz –LTE-10M downlink (highest frequency) 30MHz-1GHz

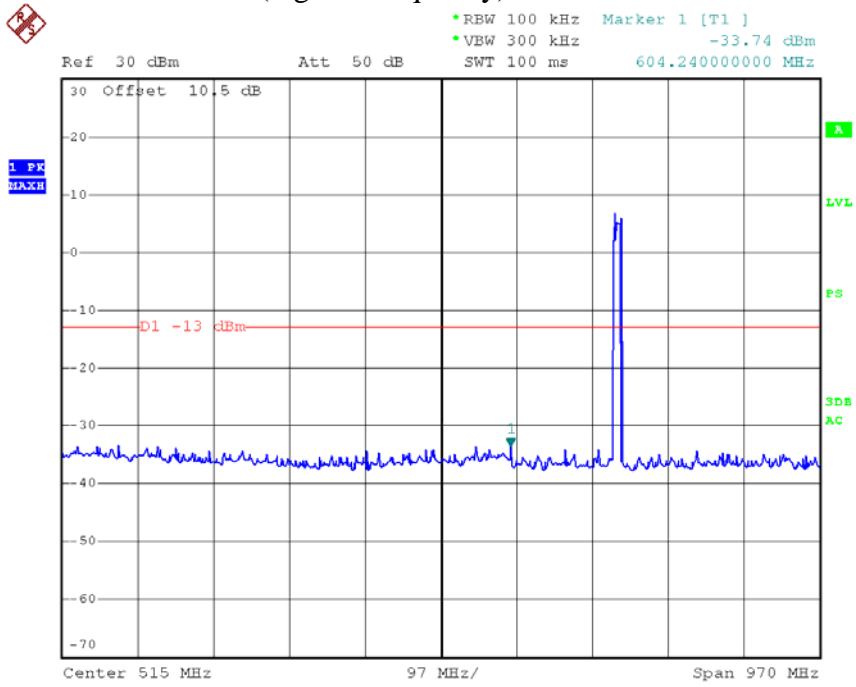

700MHz –LTE-10M downlink (highest frequency) Above 1GHz

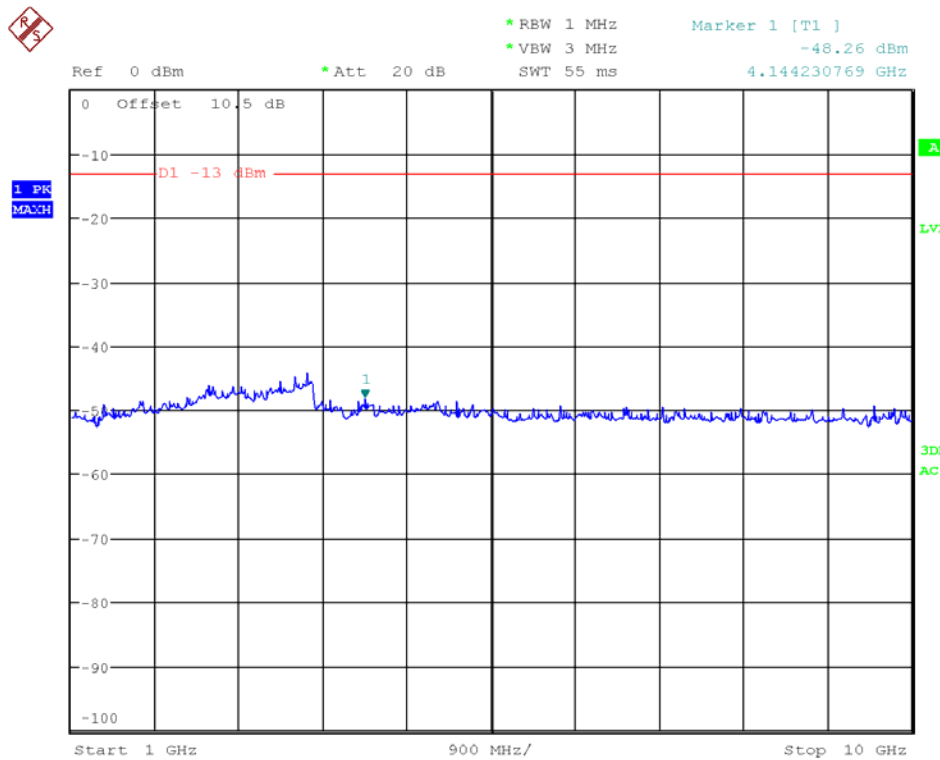

700MHz –LTE-10M uplink (lowest frequency) 30MHz-1GHz

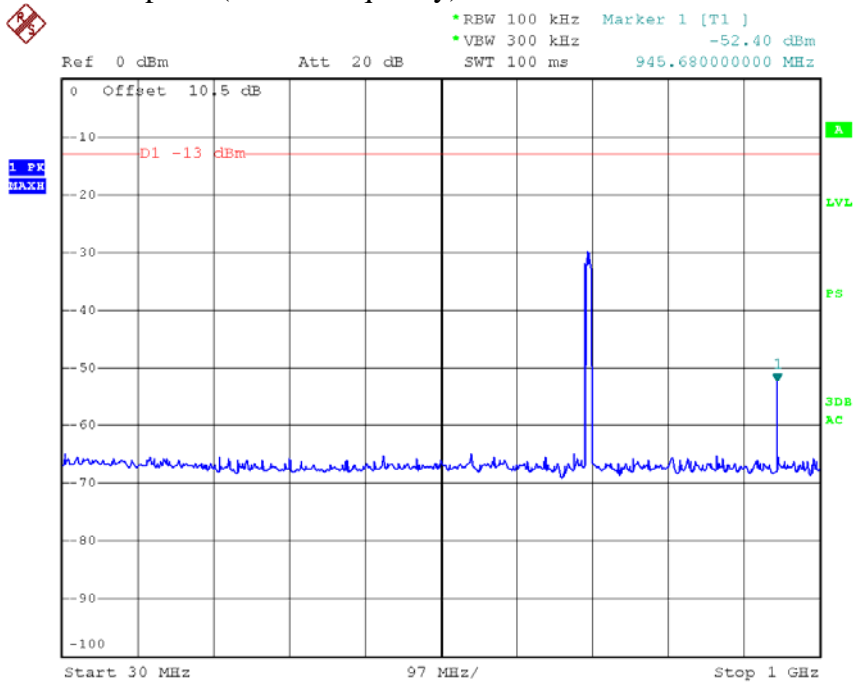

700MHz –LTE-10M uplink (lowest frequency) Above 1GHz

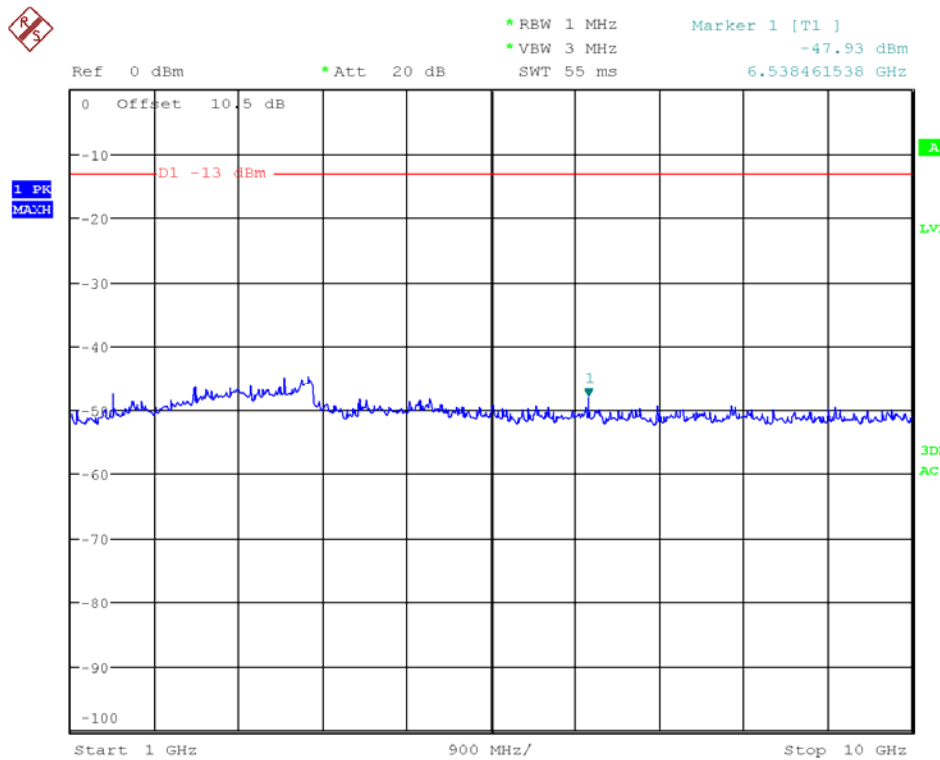

700MHz –LTE-10M uplink (middle frequency) 30MHz-1GHz

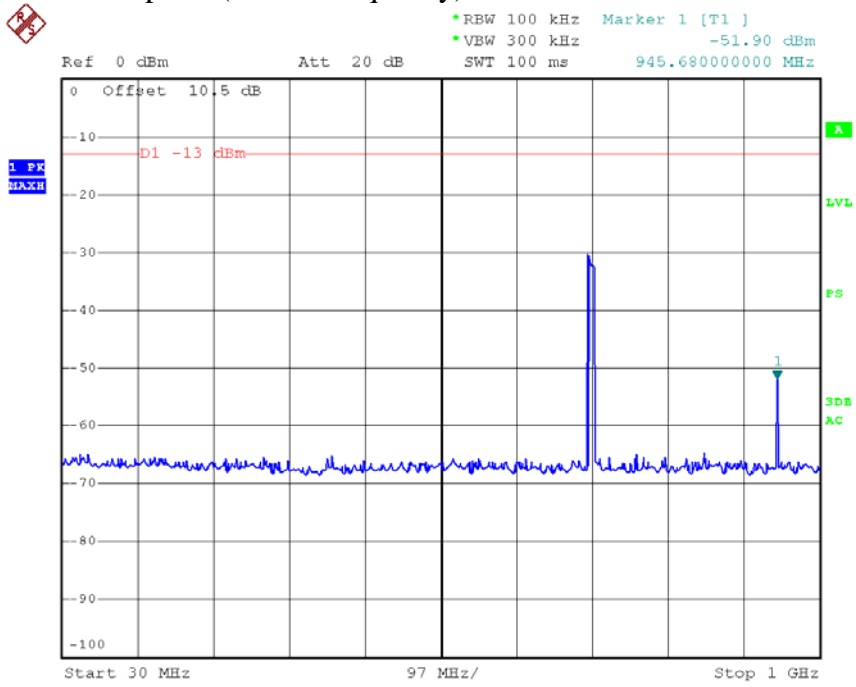

700MHz –LTE-10M uplink(middle frequency) Above 1GHz

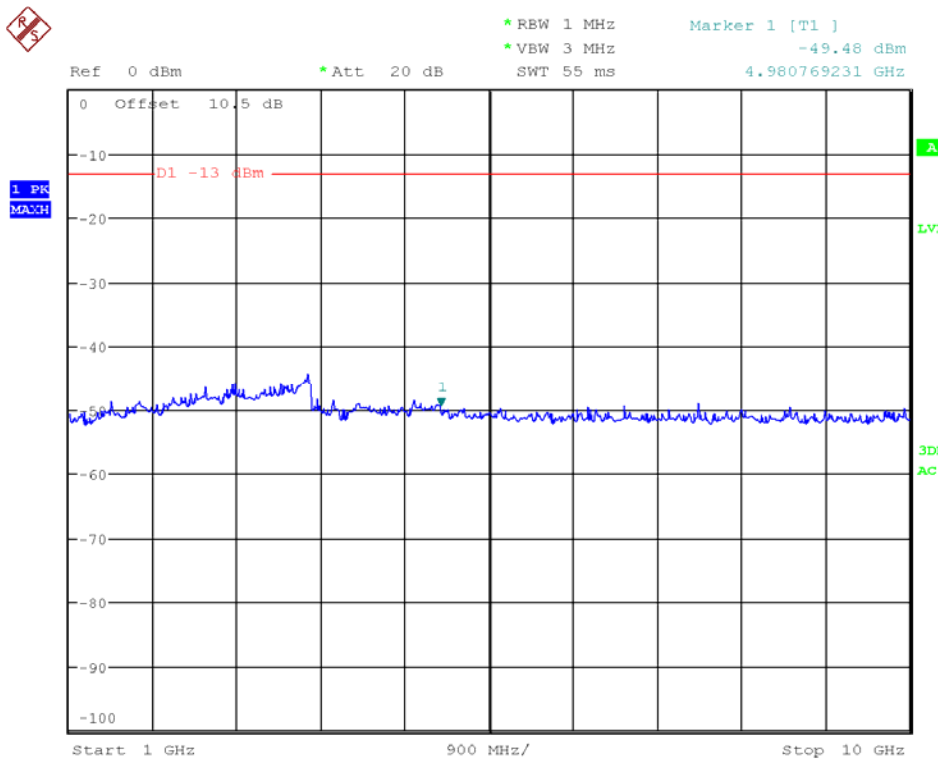

700MHz –LTE-10M uplink (highest frequency) 30MHz-1GHz

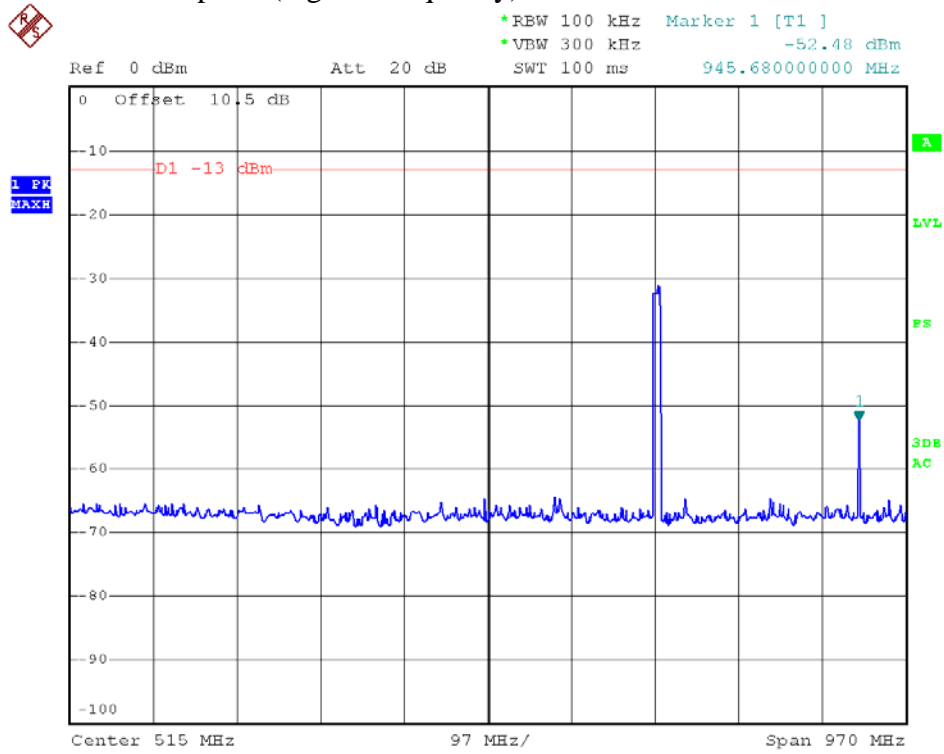

700MHz –LTE-10M uplink (highest frequency) Above 1GHz

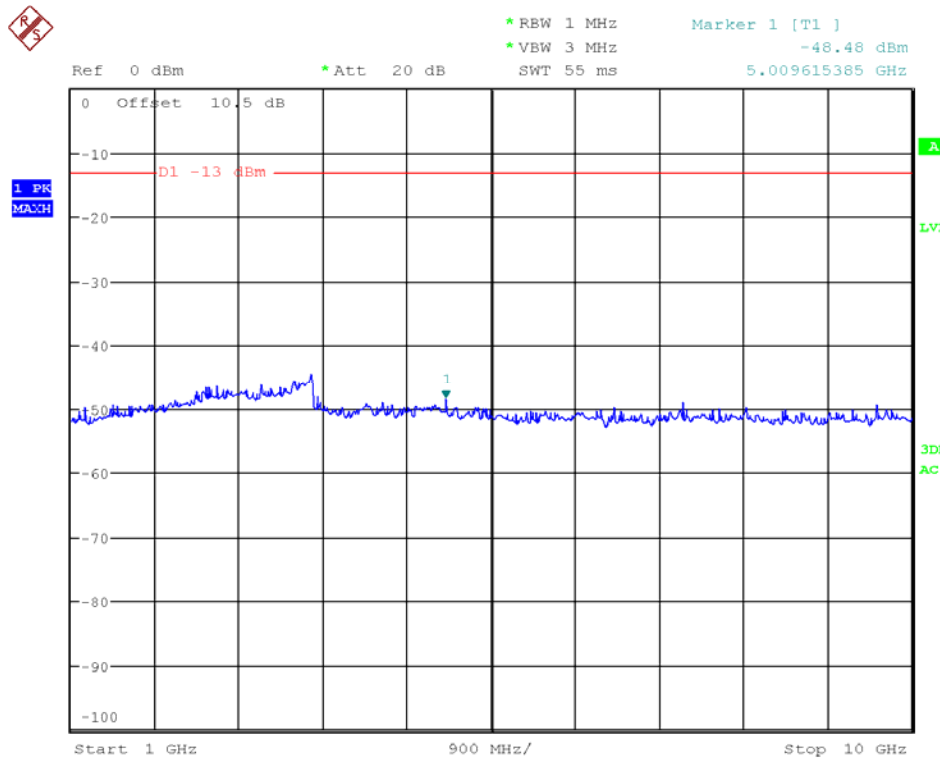

700MHz -LTE-15M downlink (lowest frequency) 30MHz-1GHz

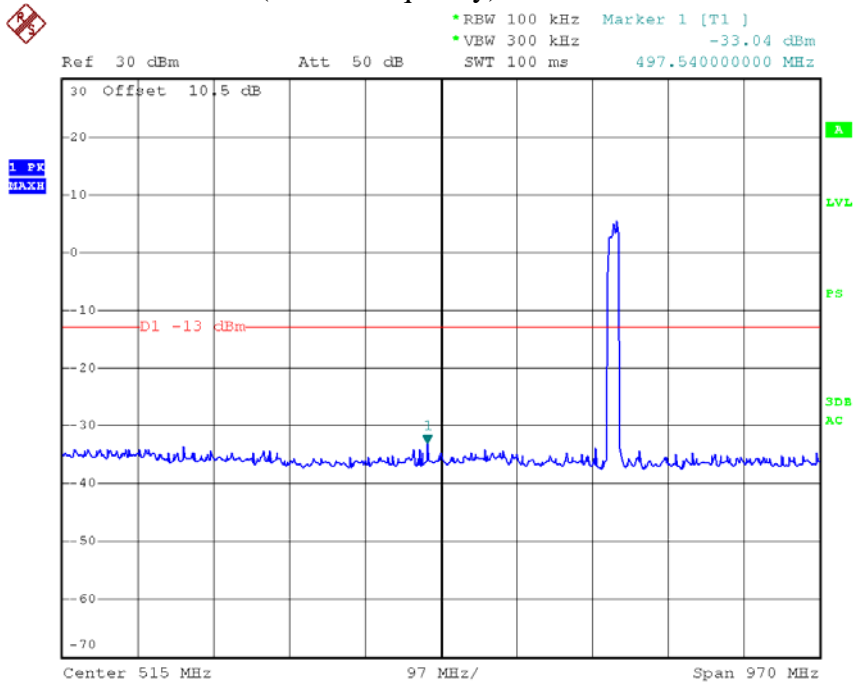

700MHz -LTE-15M downlink (lowest frequency) Above 1GHz

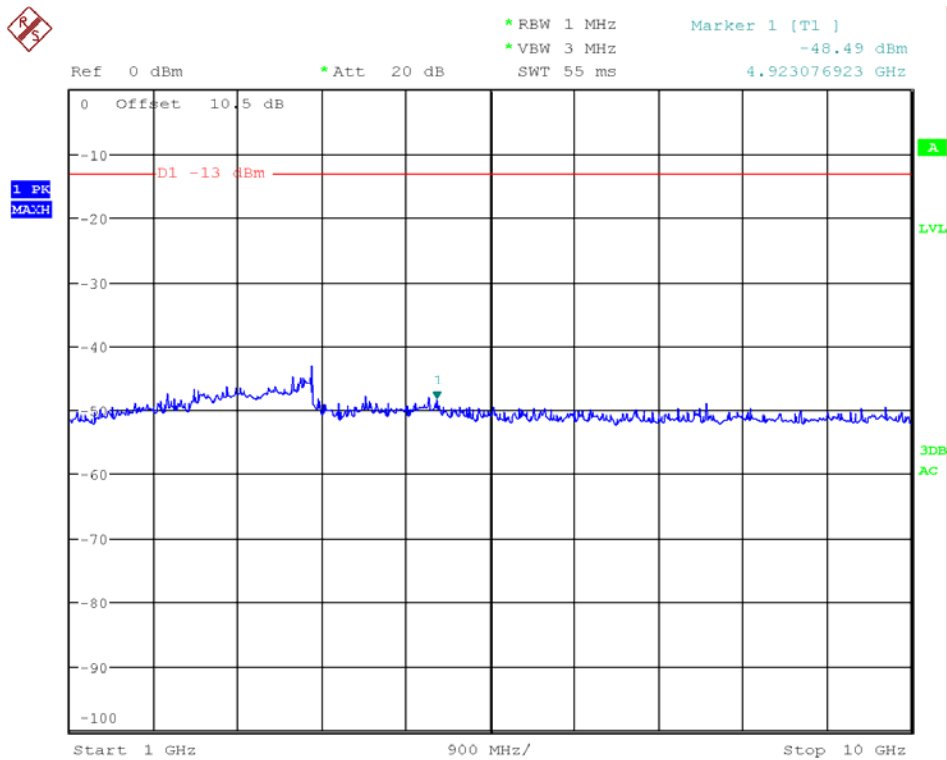

700MHz -LTE-15M downlink (middle frequency) 30MHz-1GHz

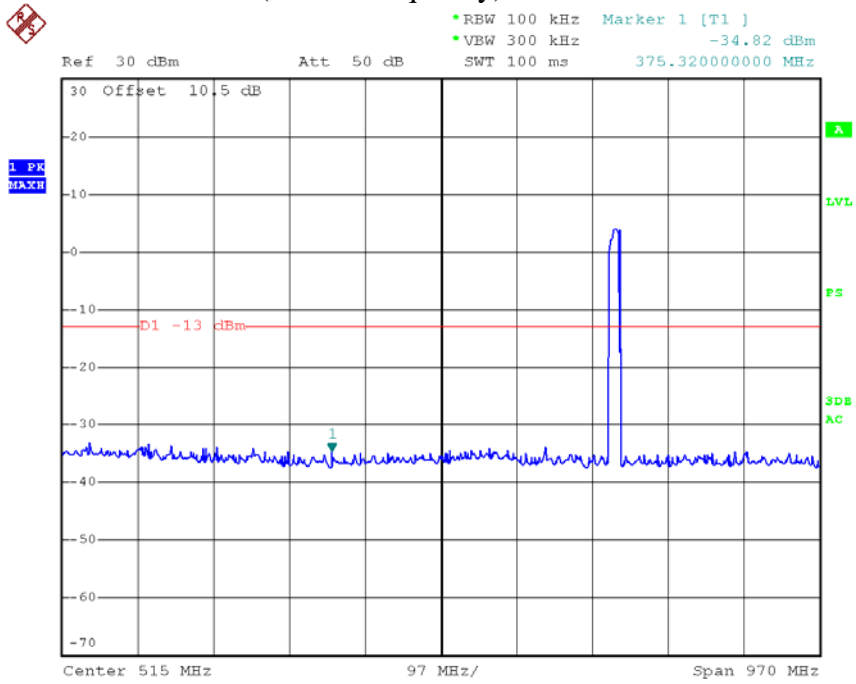

700MHz -LTE-15M downlink (middle frequency) Above 1GHz

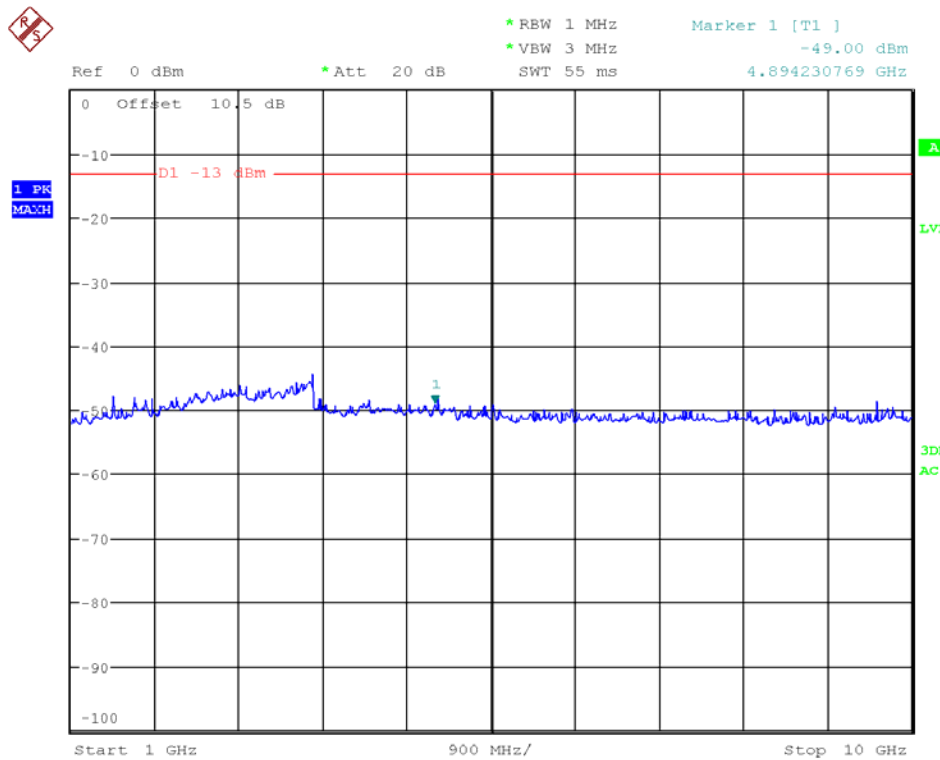

700MHz –LTE-15M downlink (highest frequency) 30MHz-1GHz

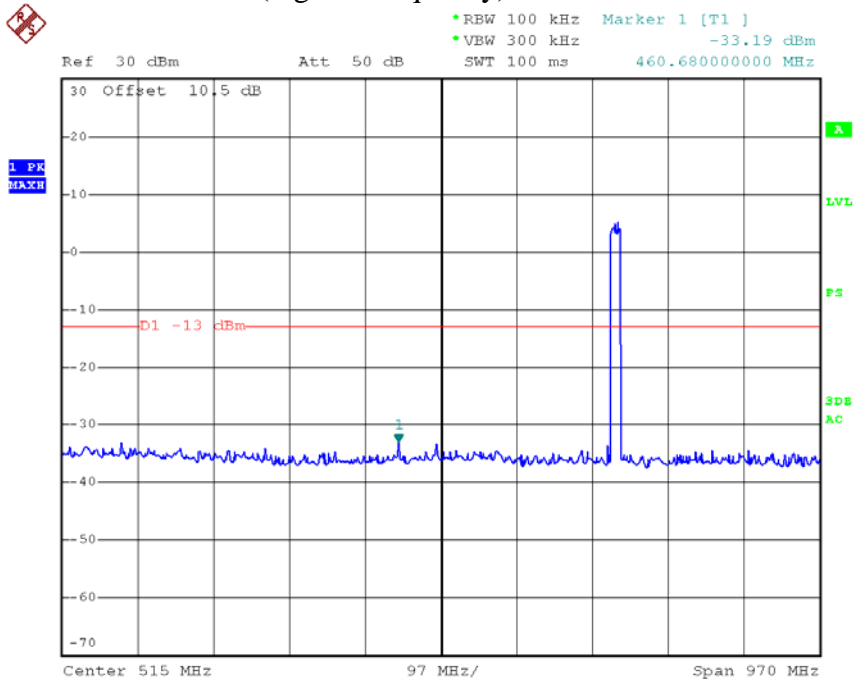

700MHz –LTE-15M downlink (highest frequency) Above 1GHz

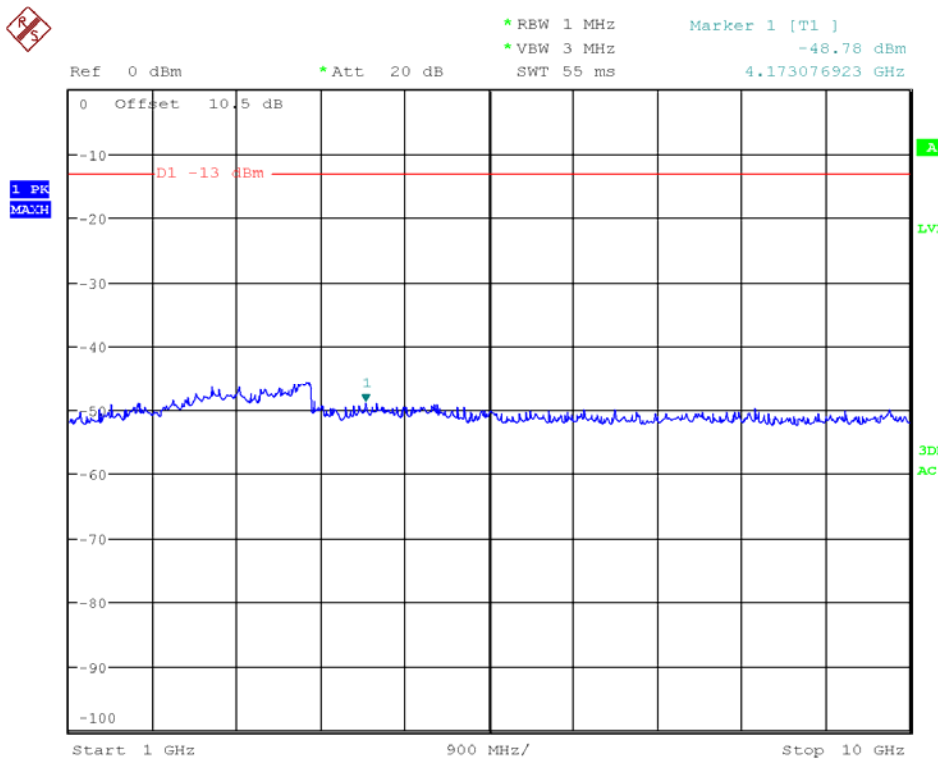

700MHz –LTE-15M uplink (lowest frequency) 30MHz-1GHz

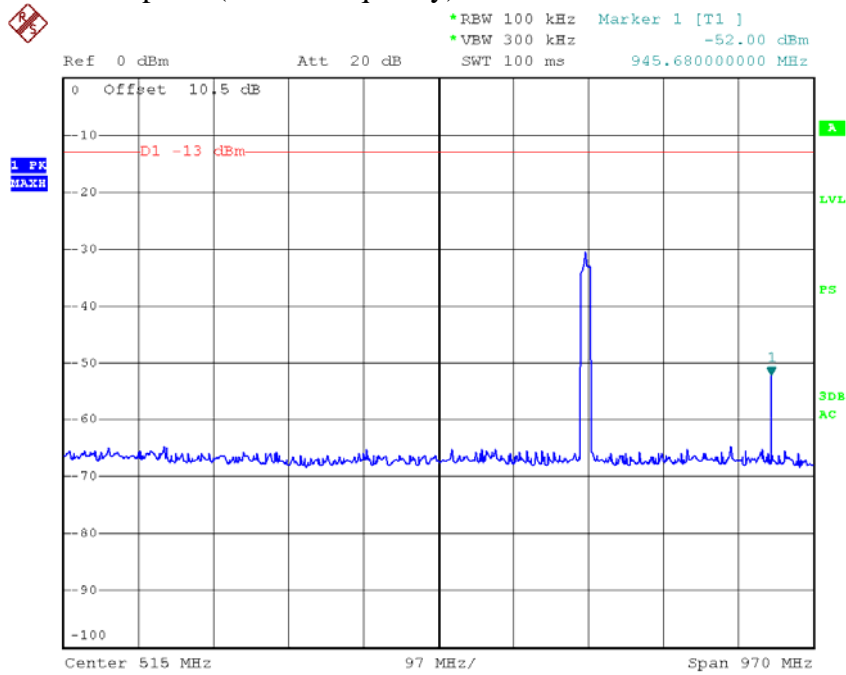

700MHz –LTE-15M uplink (lowest frequency) Above 1GHz

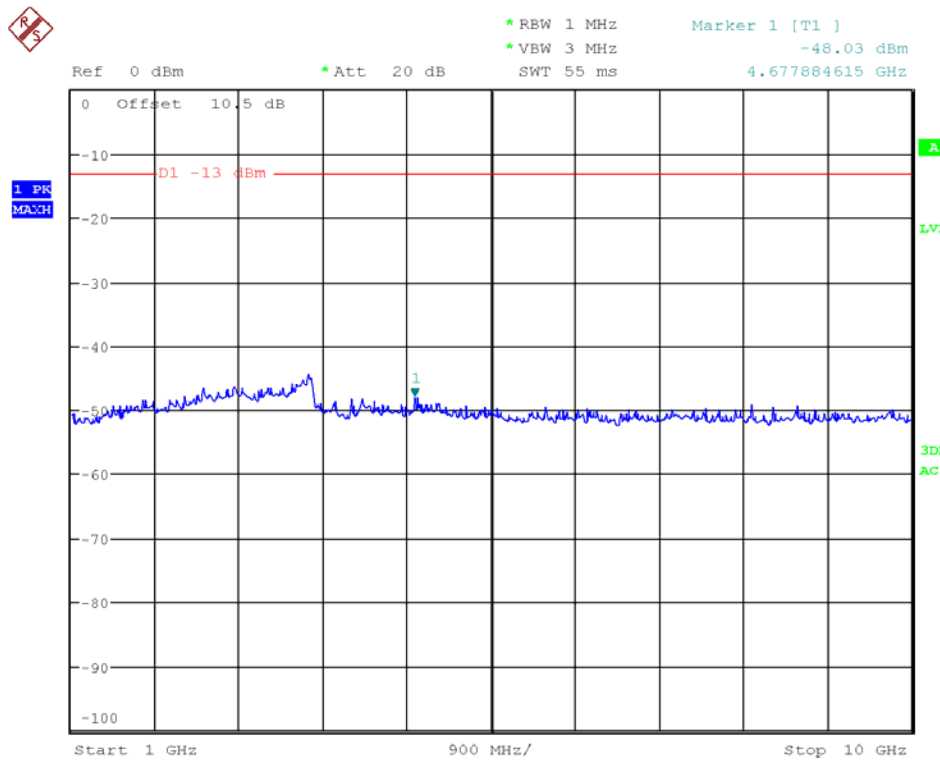

700MHz –LTE-15M uplink (middle frequency) 30MHz-1GHz

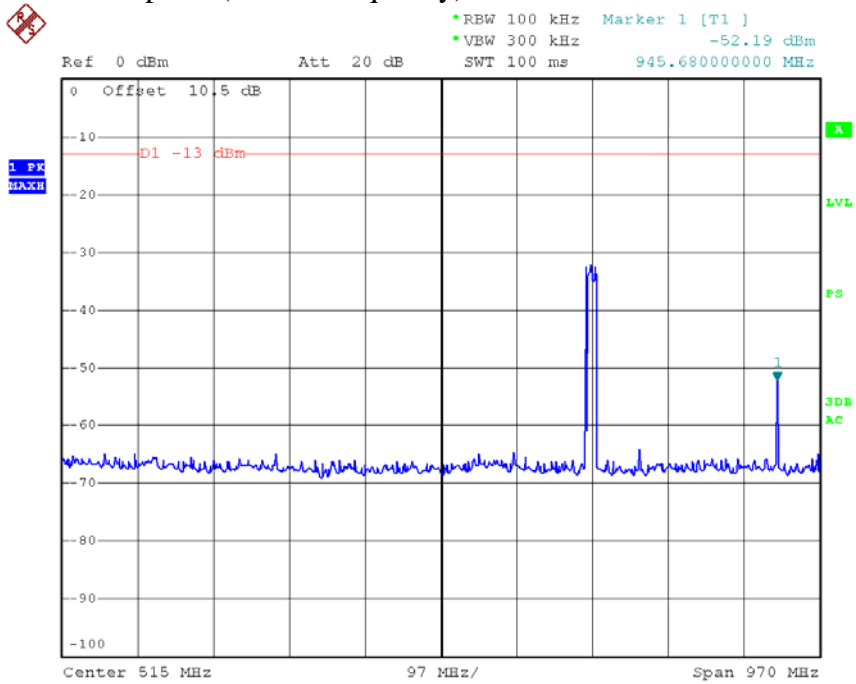

700MHz –LTE-15M uplink(middle frequency) Above 1GHz

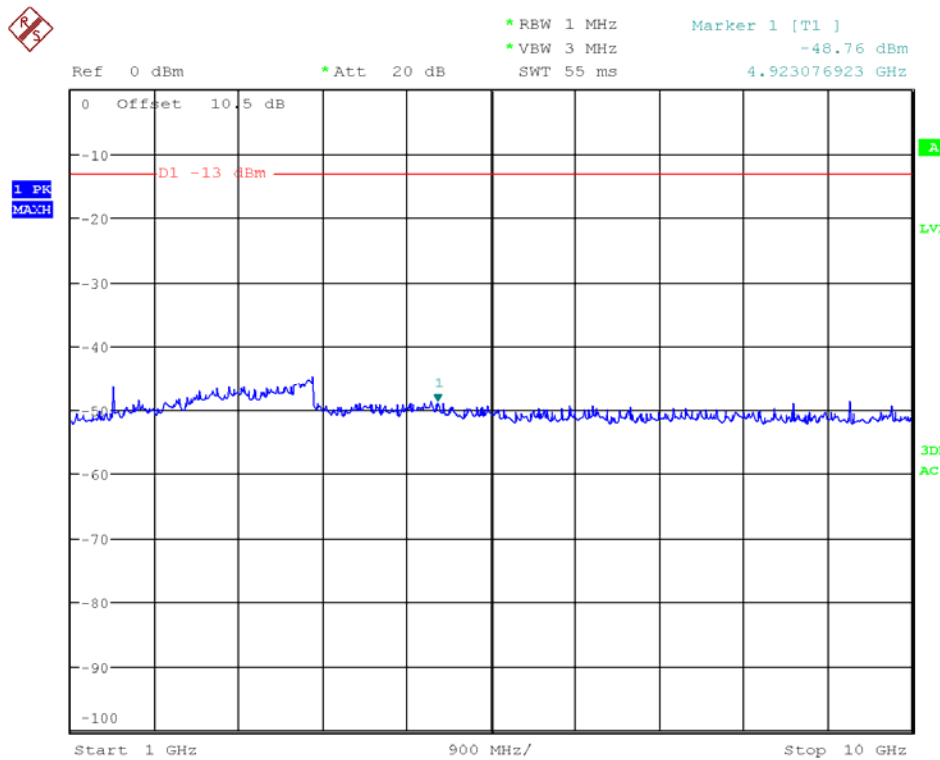

700MHz –LTE-15M uplink (highest frequency) 30MHz-1GHz

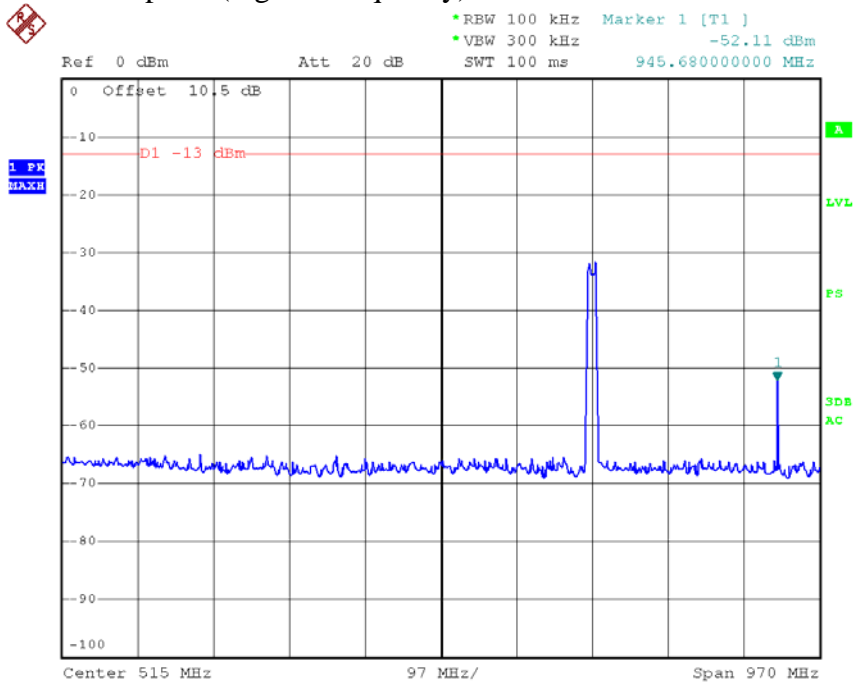

700MHz –LTE-15M uplink (highest frequency) Above 1GHz

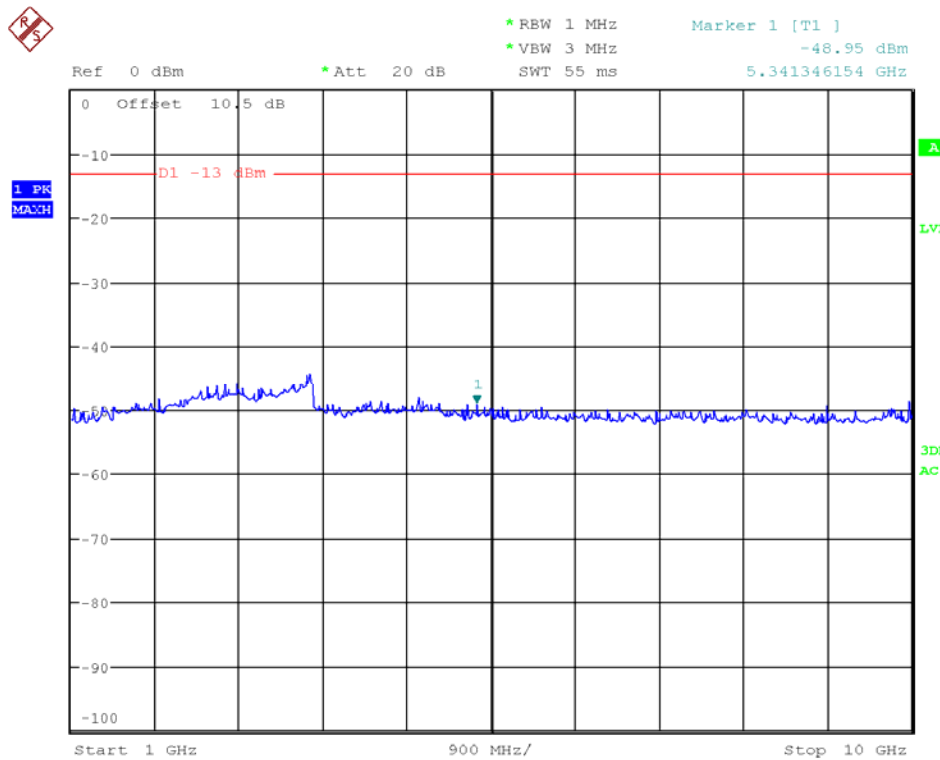

2100MHz –LTE-1.4M downlink (lowest frequency) 30MHz-1GHz

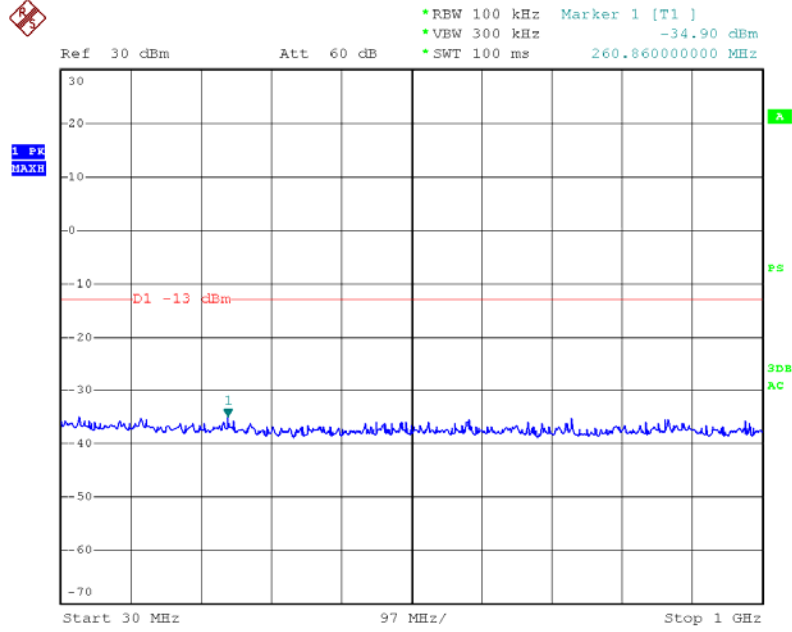

2100MHz –LTE-1.4M downlink (lowest frequency) Above 1GHz

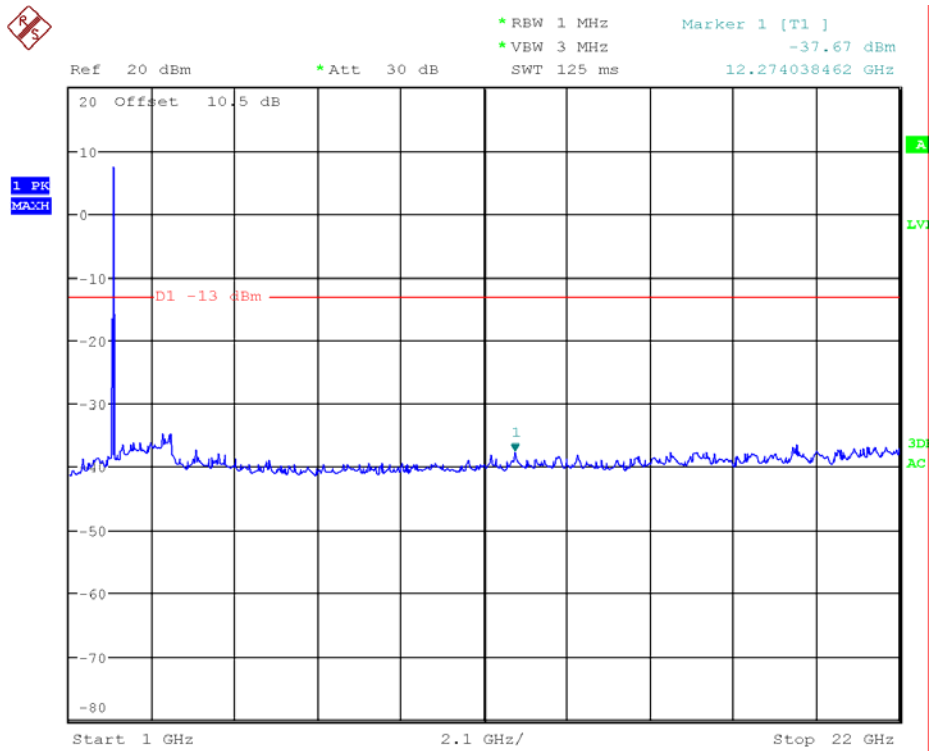

2100MHz -LTE-1.4M downlink (middle frequency) 30MHz-1GHz

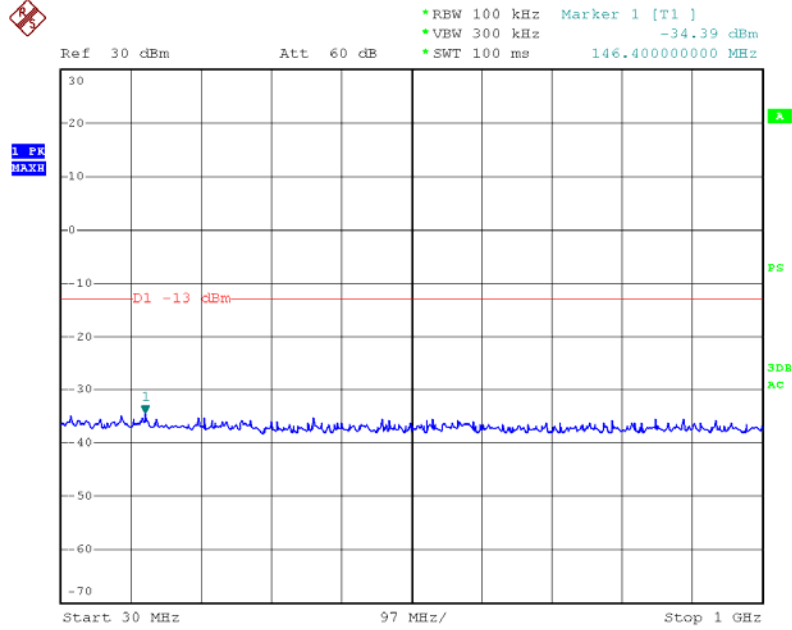

2100MHz -LTE-1.4M downlink (middle frequency) Above 1GHz

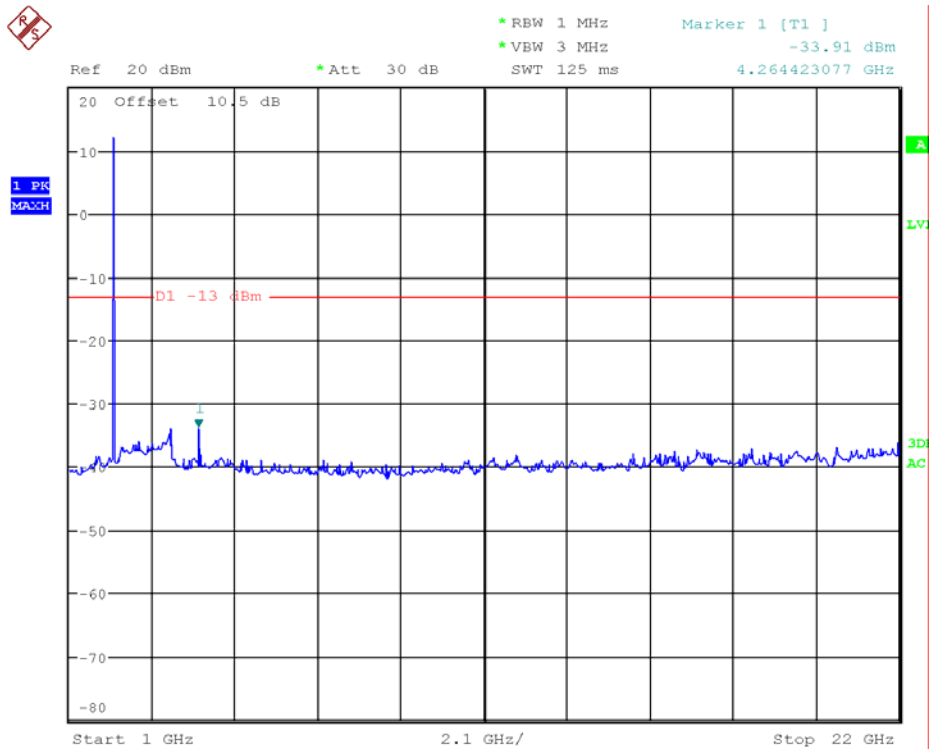

2100MHz –LTE-1.4M downlink (highest frequency) 30MHz-1GHz

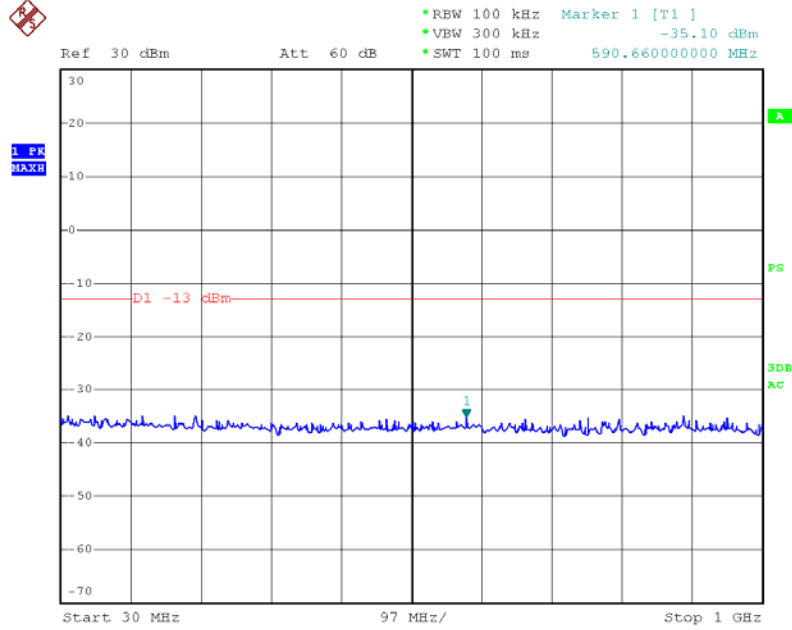

2100MHz –LTE-1.4M downlink (highest frequency) Above 1GHz

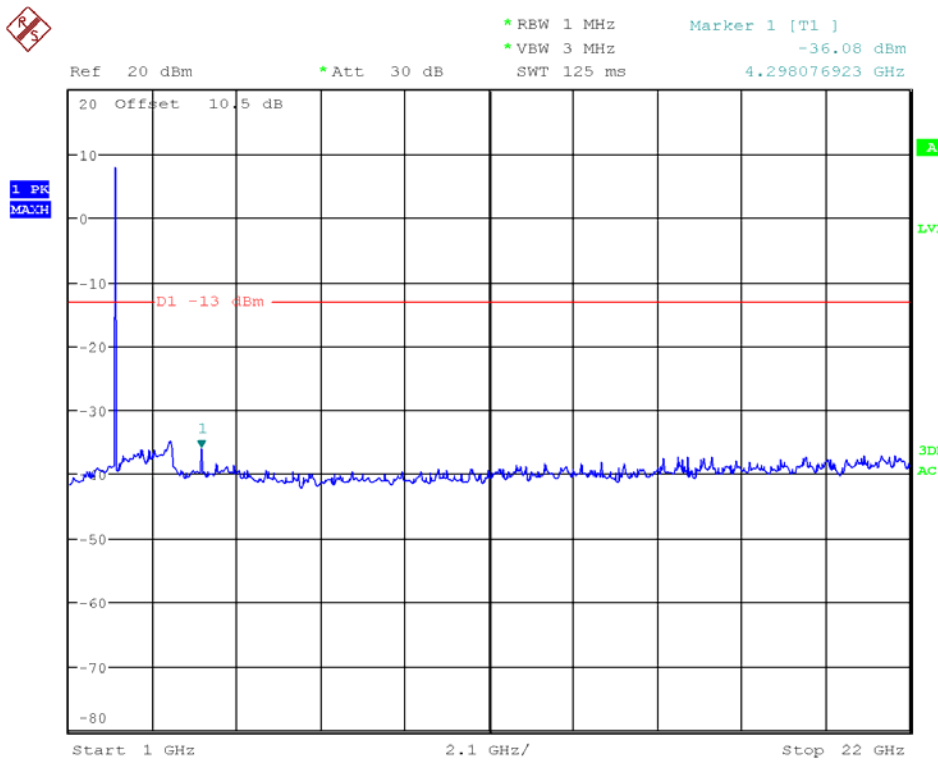

2100MHz -LTE-1.4M uplink (lowest frequency) 30MHz-1GHz

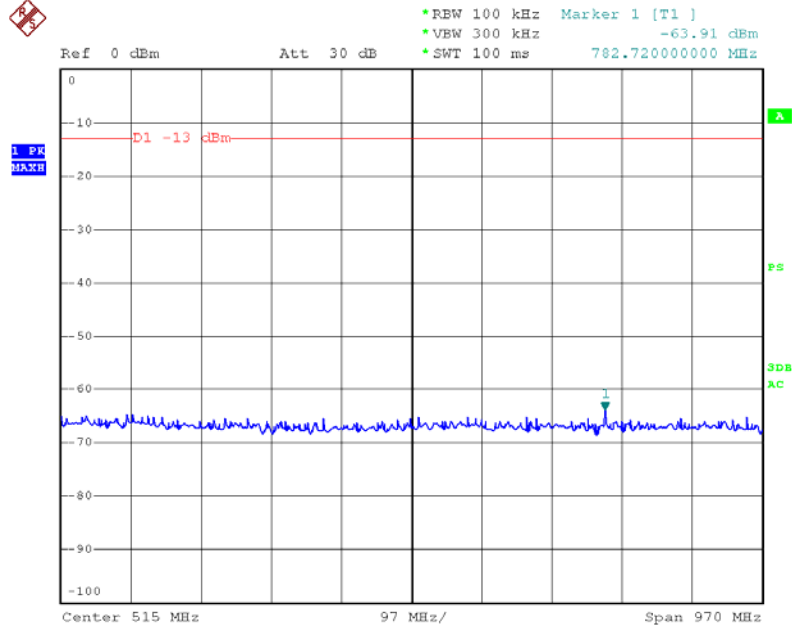

2100MHz -LTE-1.4M uplink (lowest frequency) Above 1GHz

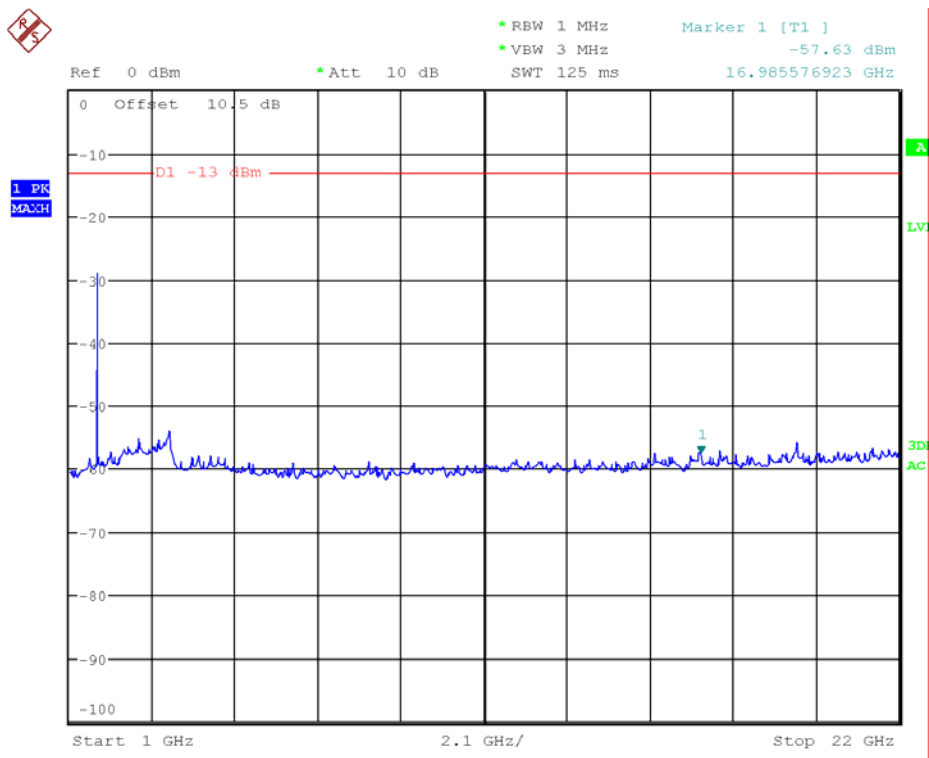

2100MHz -LTE-1.4M uplink (middle frequency) 30MHz-1GHz

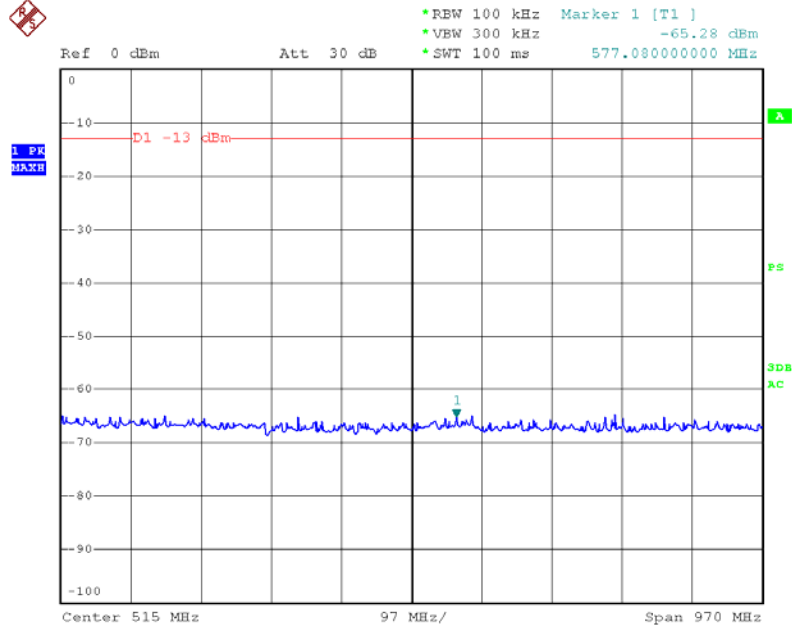

2100MHz -LTE-1.4M uplink(middle frequency) Above 1GHz

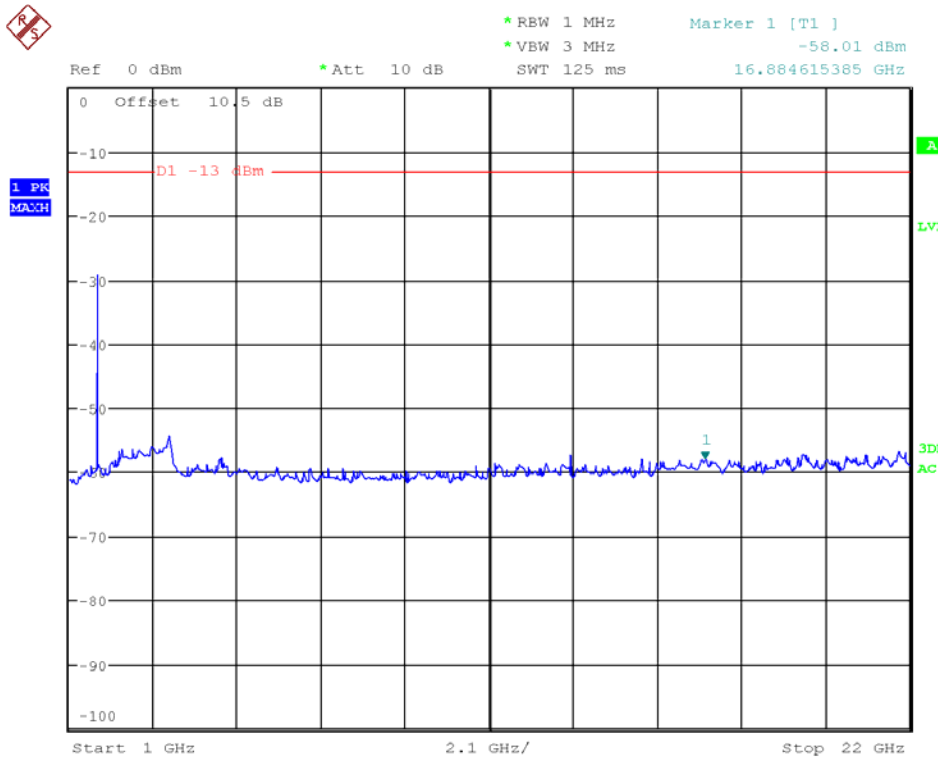

2100MHz –LTE-1.4M uplink (highest frequency) 30MHz-1GHz

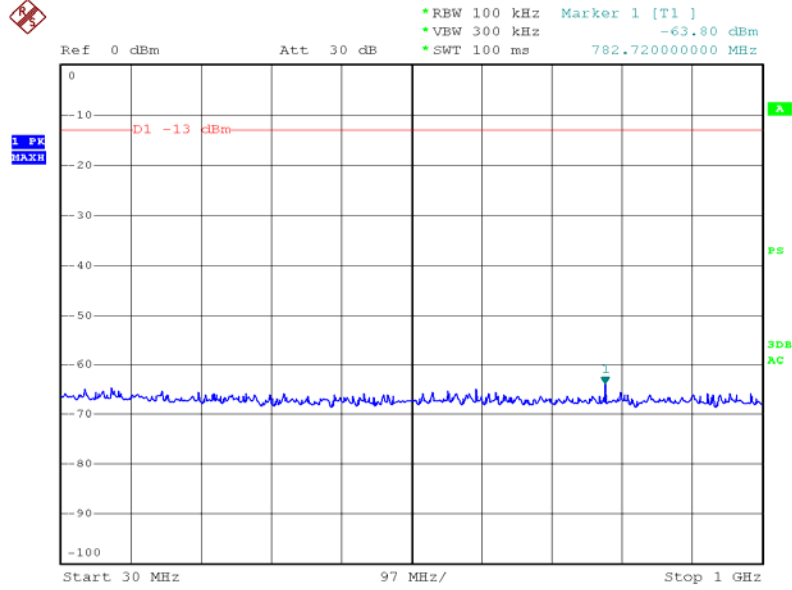

2100MHz –LTE-1.4M uplink (highest frequency) Above 1GHz

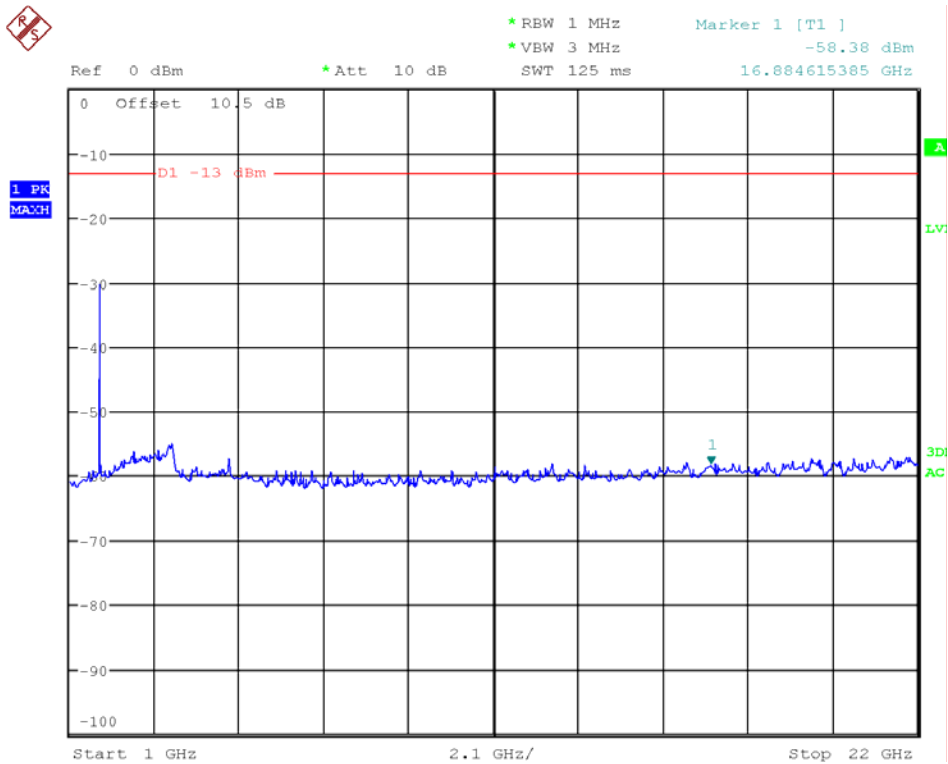

2100MHz –LTE-3M downlink (lowest frequency) 30MHz-1GHz

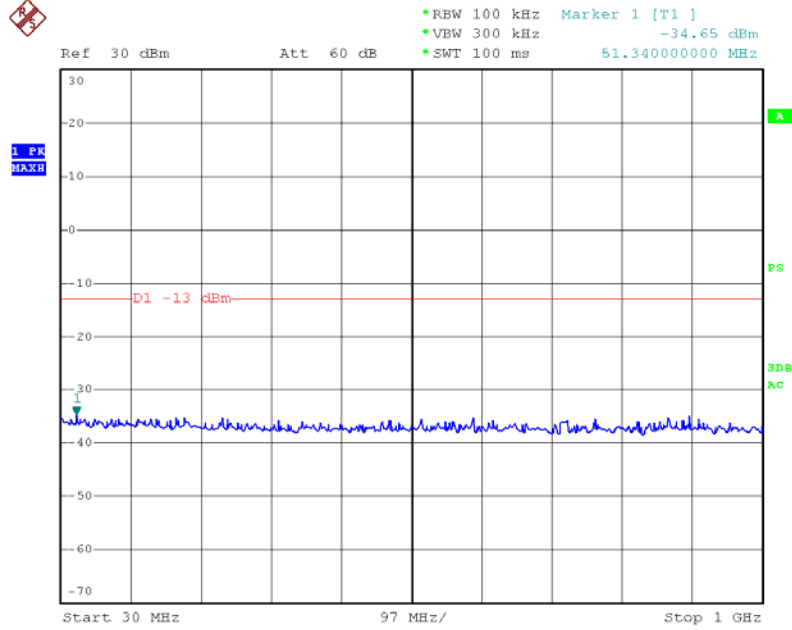

2100MHz –LTE-3M downlink (lowest frequency) Above 1GHz

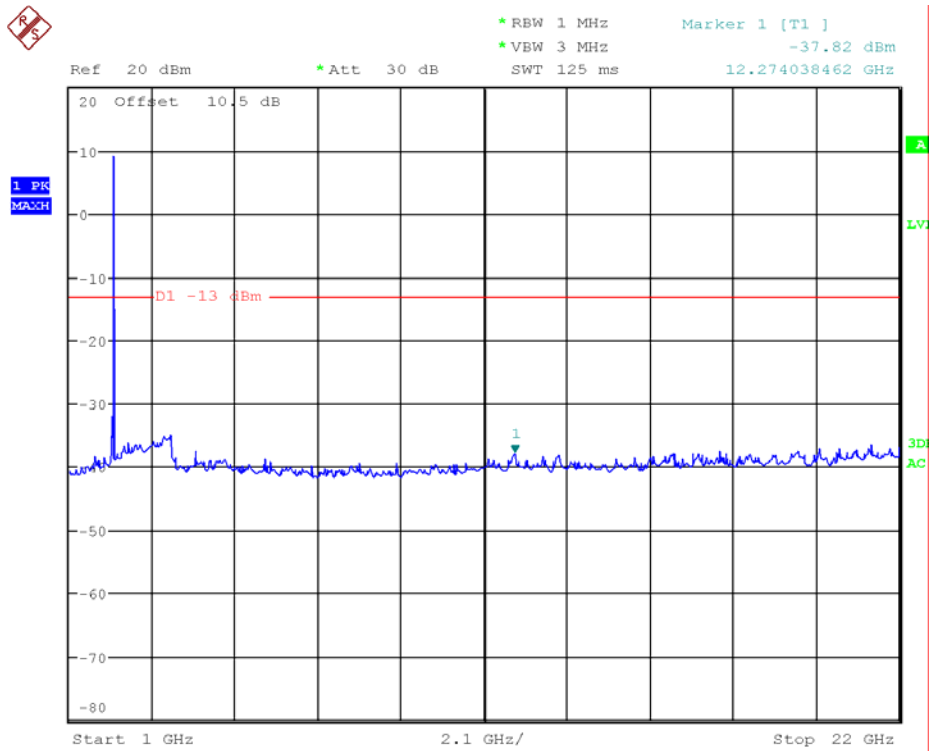

2100MHz -LTE-3M downlink (middle frequency) 30MHz-1GHz

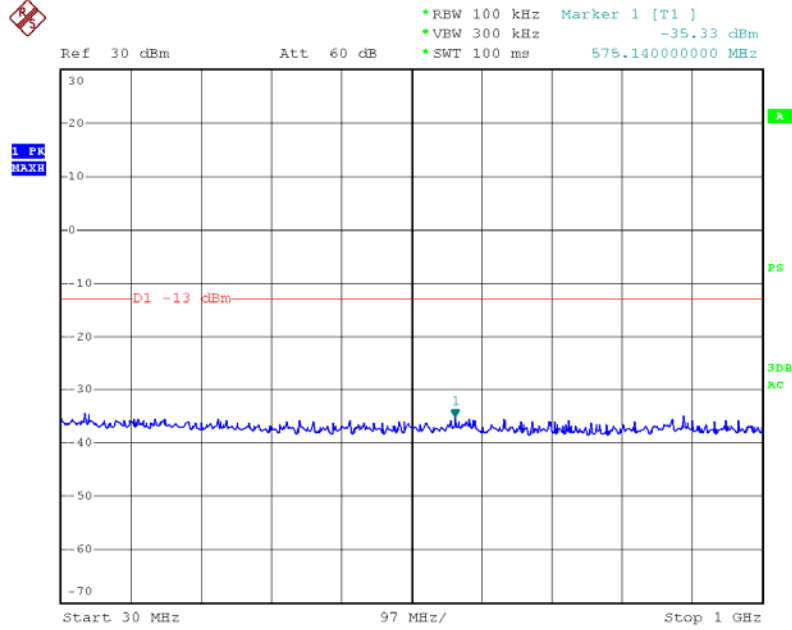

2100MHz -LTE-3M downlink (middle frequency) Above 1GHz

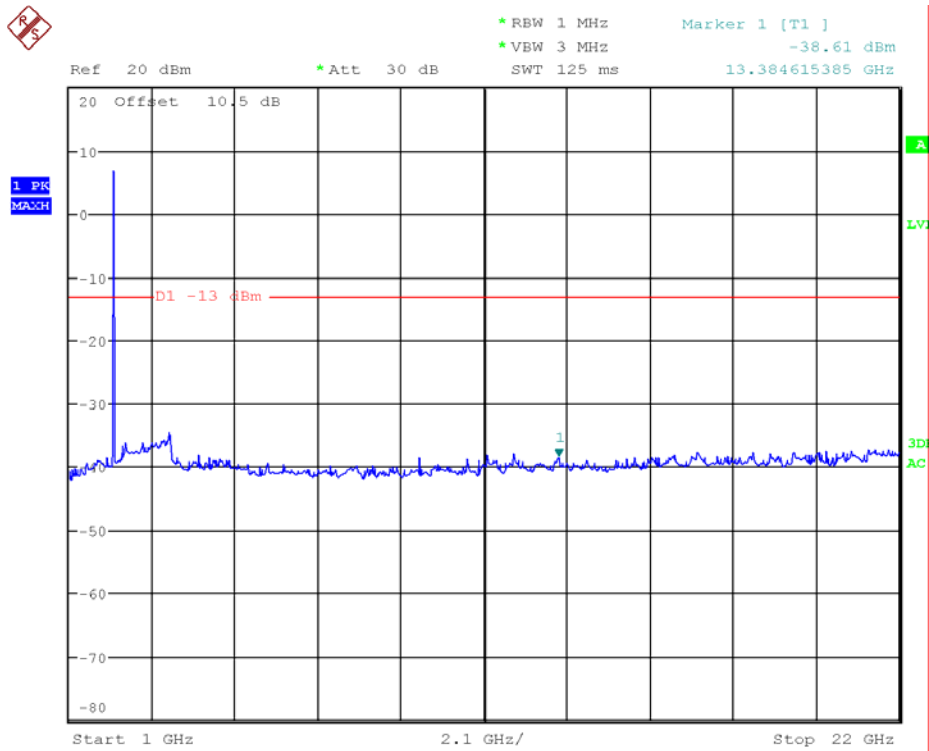

2100MHz –LTE-3M downlink (highest frequency) 30MHz-1GHz

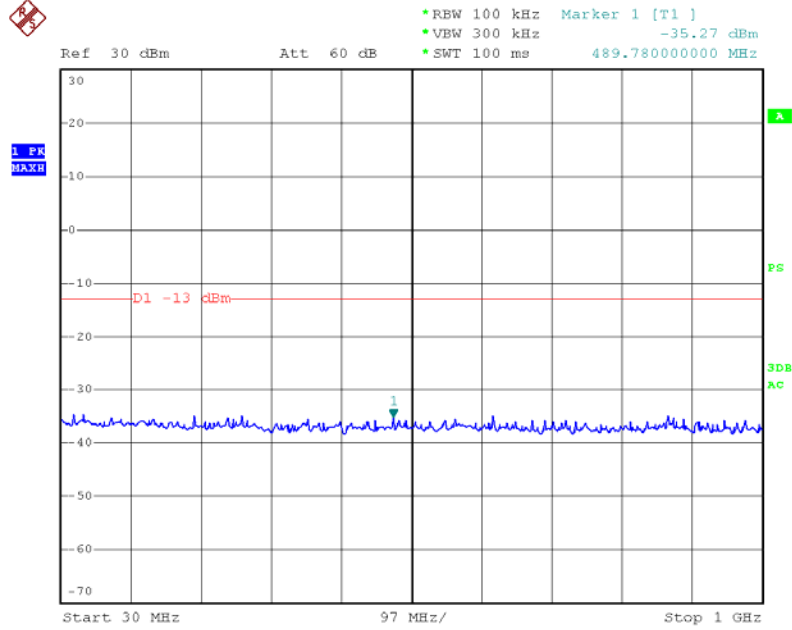

2100MHz –LTE-3M downlink (highest frequency) Above 1GHz

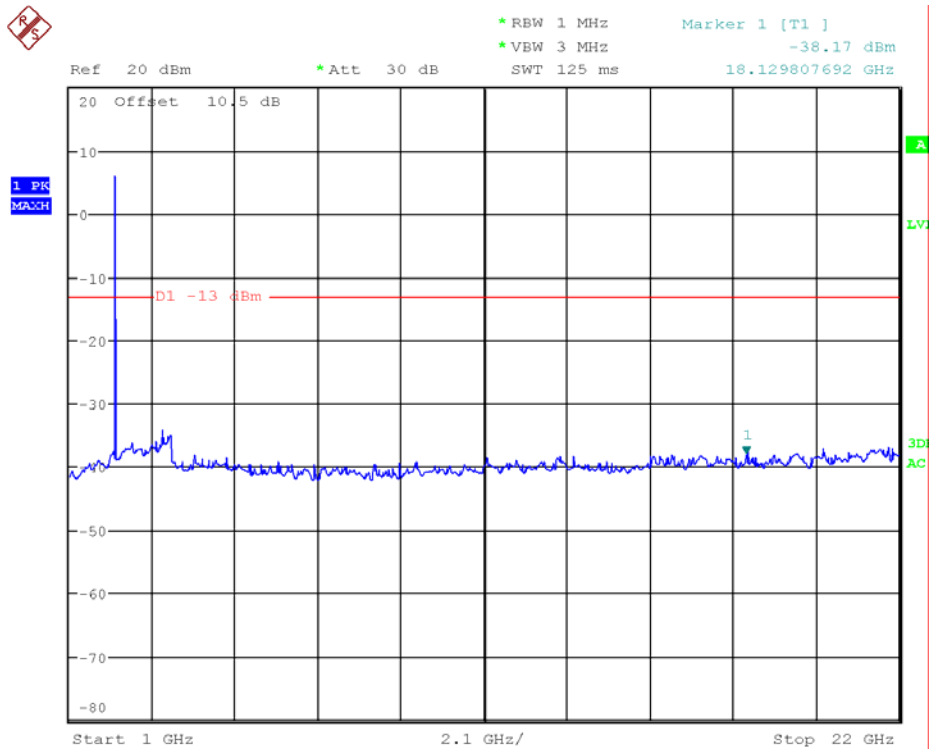

2100MHz –LTE-3M uplink (lowest frequency) 30MHz-1GHz

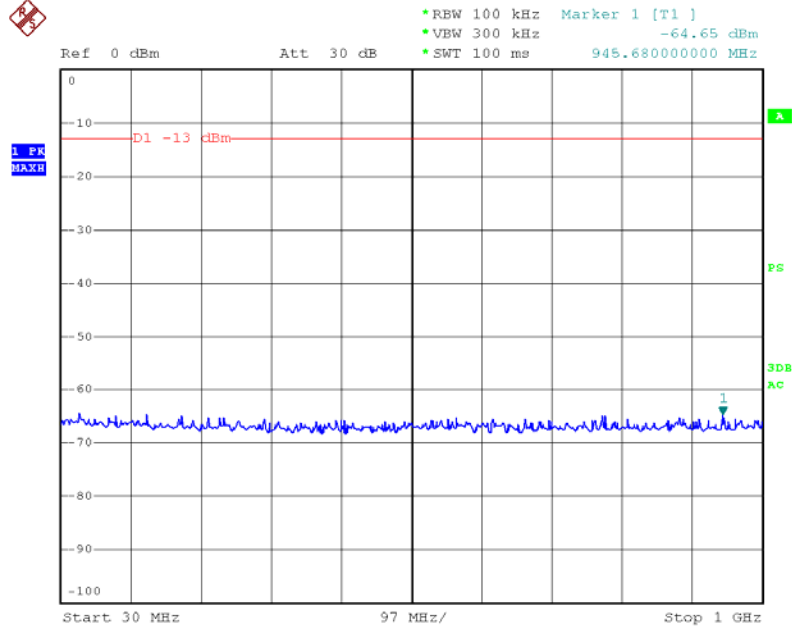

2100MHz –LTE-3M uplink (lowest frequency) Above 1GHz

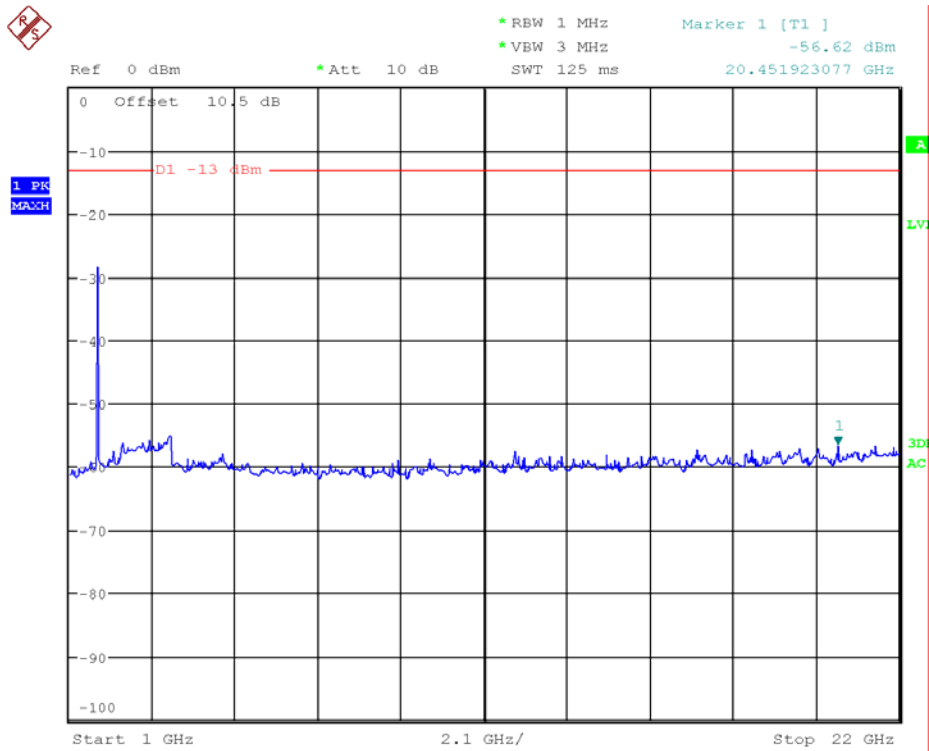

2100MHz -LTE-3M uplink (middle frequency) 30MHz-1GHz

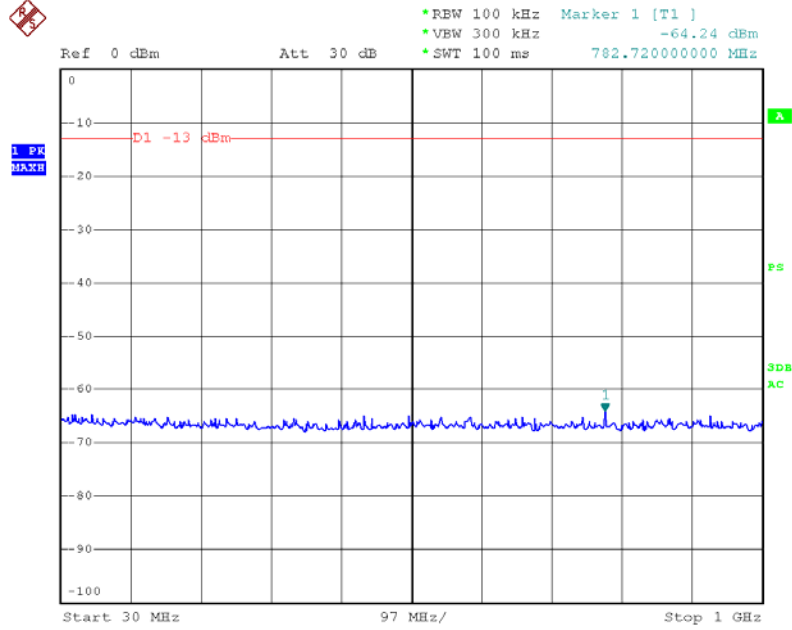

2100MHz -LTE-3M uplink(middle frequency) Above 1GHz

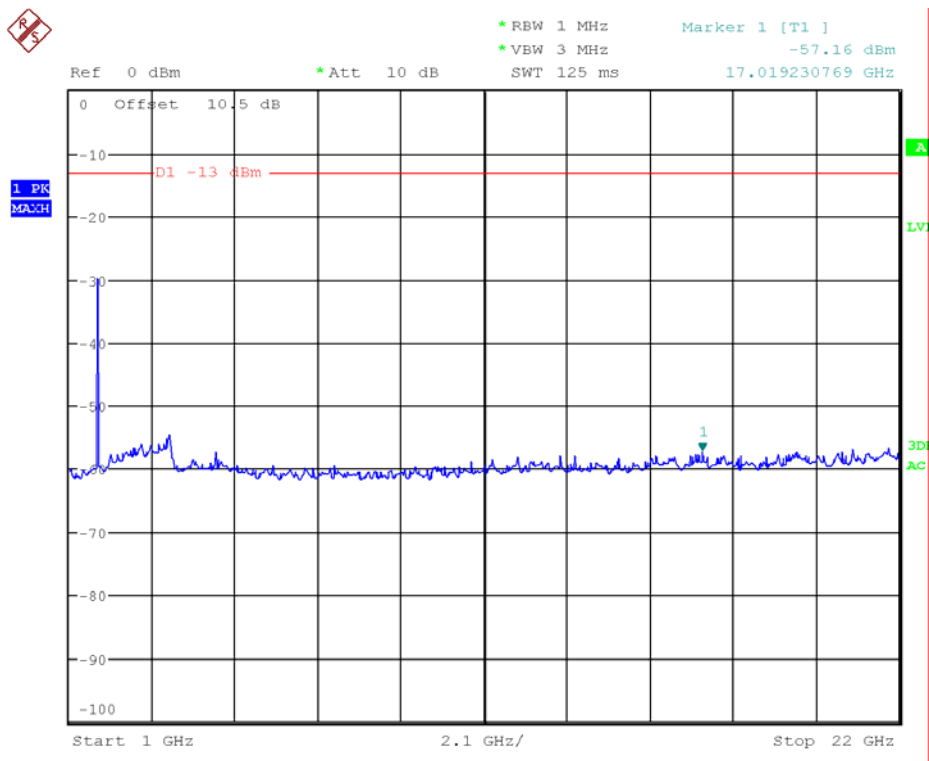

2100MHz –LTE-3M uplink (highest frequency) 30MHz-1GHz

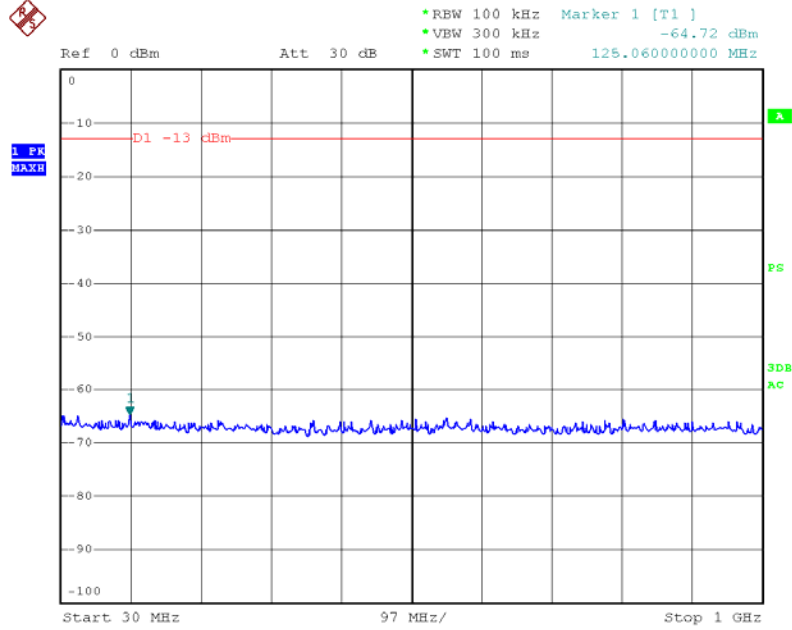

2100MHz –LTE-3M uplink (highest frequency) Above 1GHz

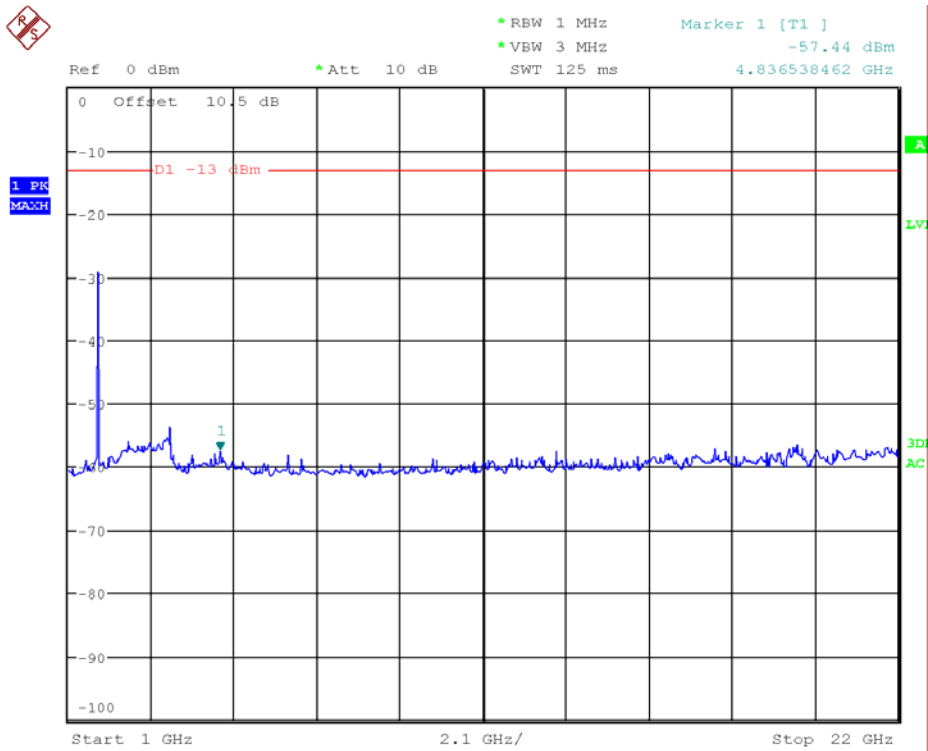

2100MHz –LTE-5M downlink (lowest frequency) 30MHz-1GHz

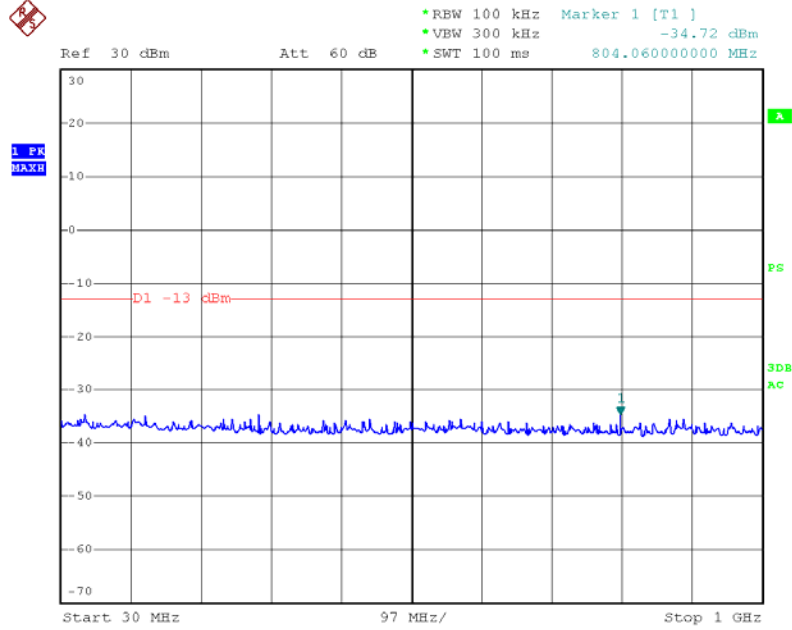

2100MHz –LTE-5M downlink (lowest frequency) Above 1GHz

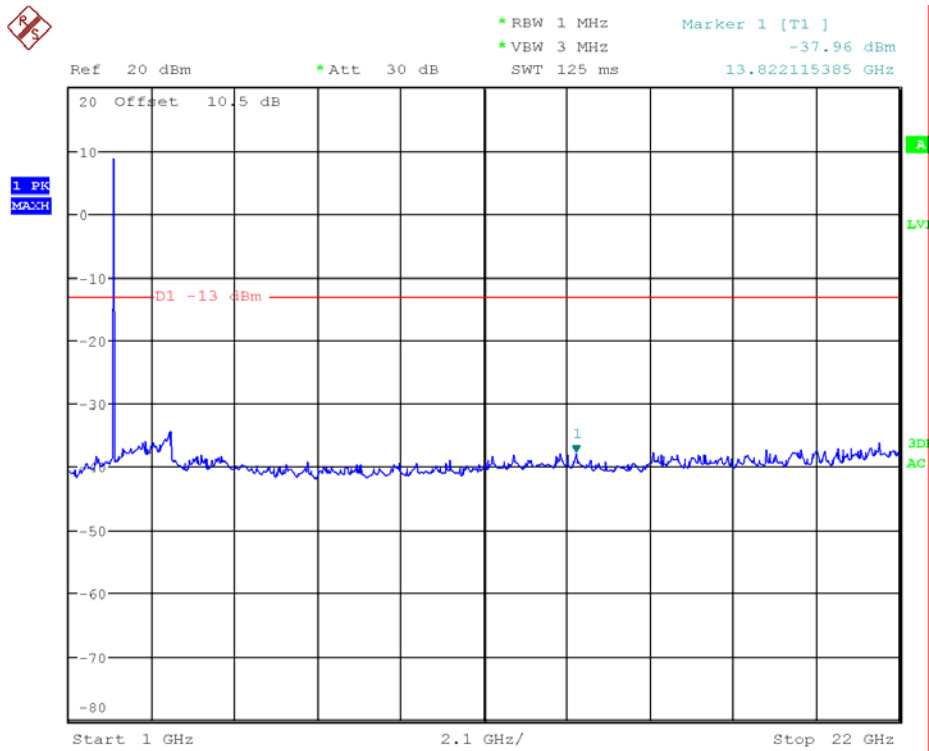

2100MHz -LTE-5M downlink (middle frequency) 30MHz-1GHz

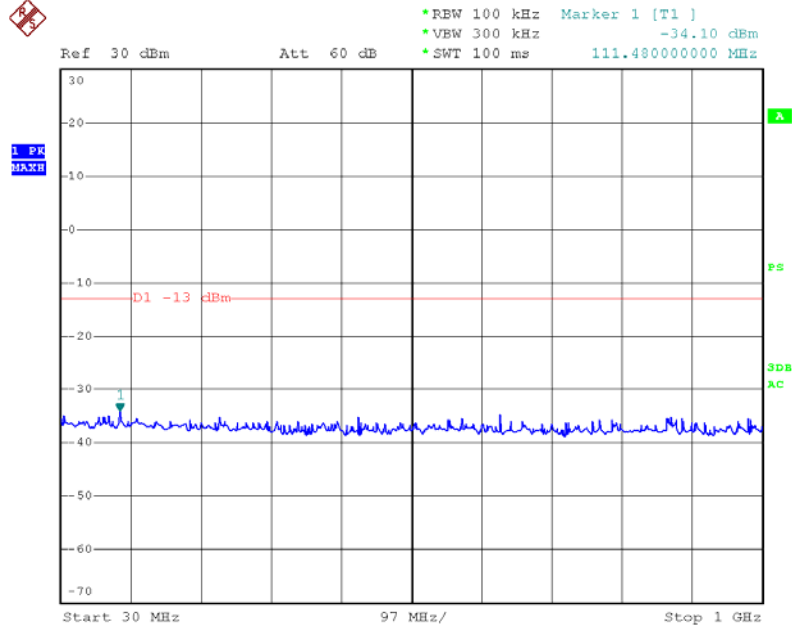

2100MHz -LTE-5M downlink (middle frequency) Above 1GHz

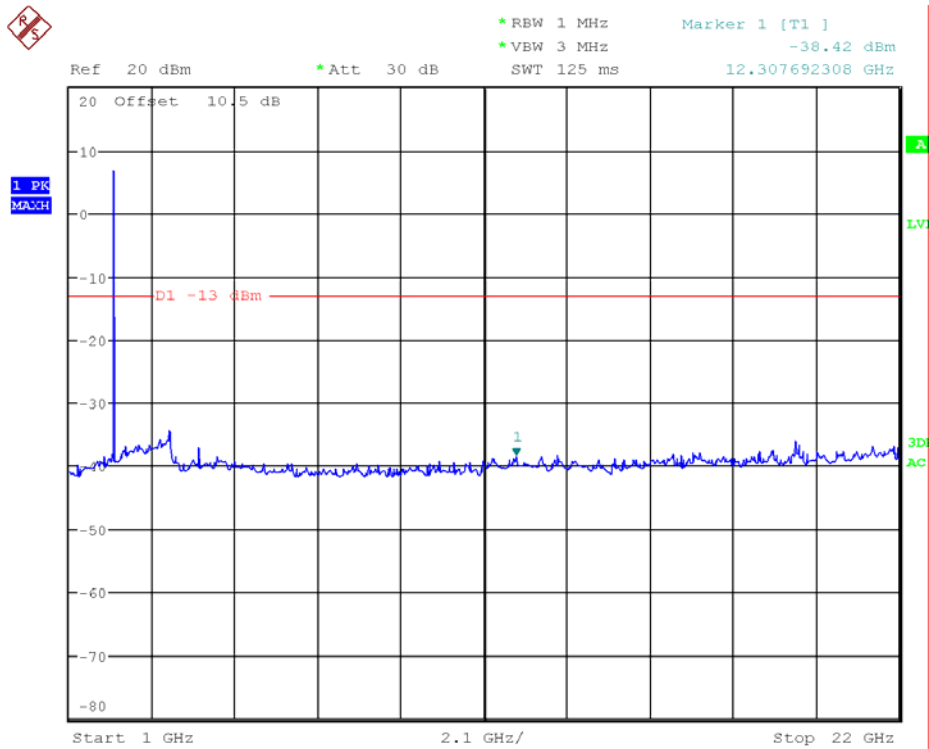

2100MHz –LTE-5M downlink (highest frequency) 30MHz-1GHz

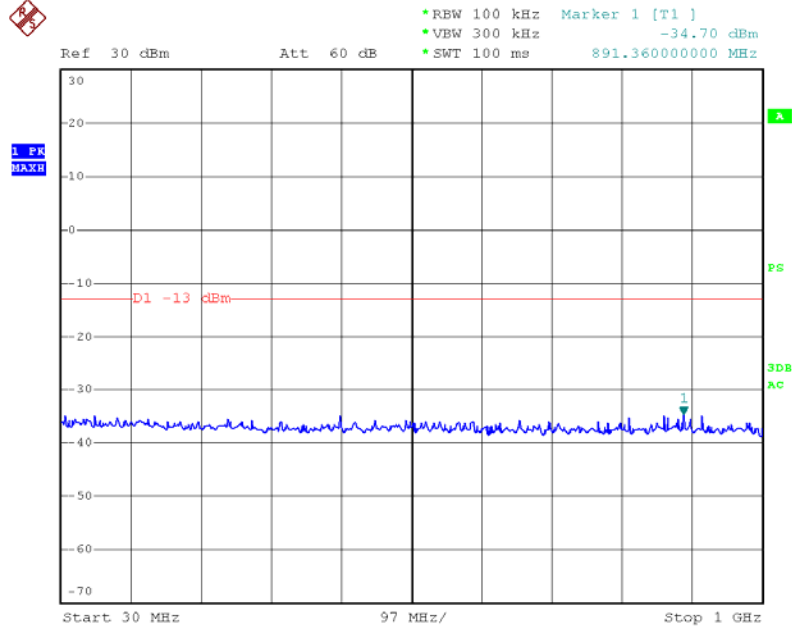

2100MHz –LTE-5M downlink (highest frequency) Above 1GHz

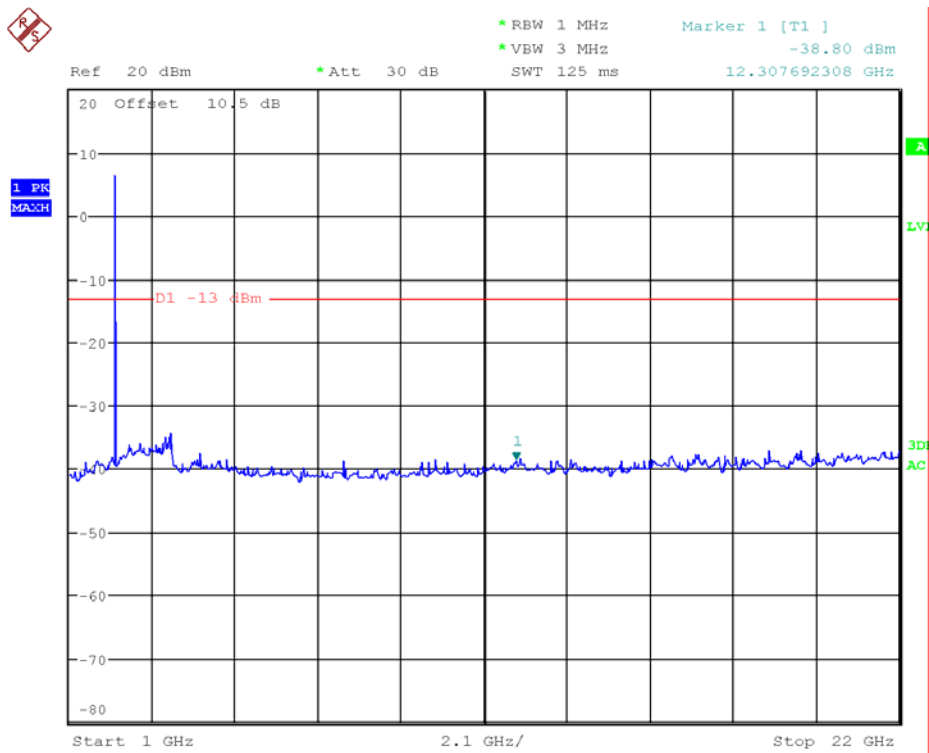

2100MHz –LTE-5M uplink (lowest frequency) 30MHz-1GHz

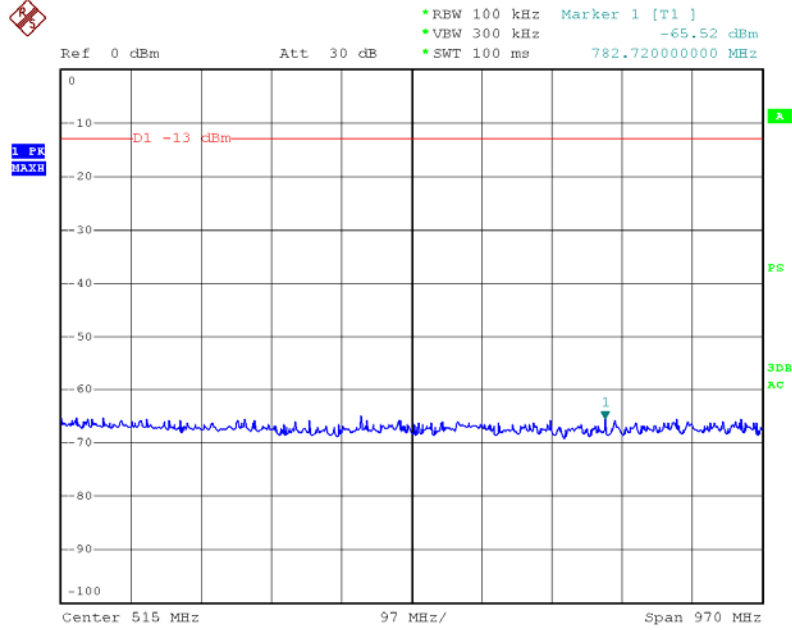

2100MHz –LTE-5M uplink (lowest frequency) Above 1GHz

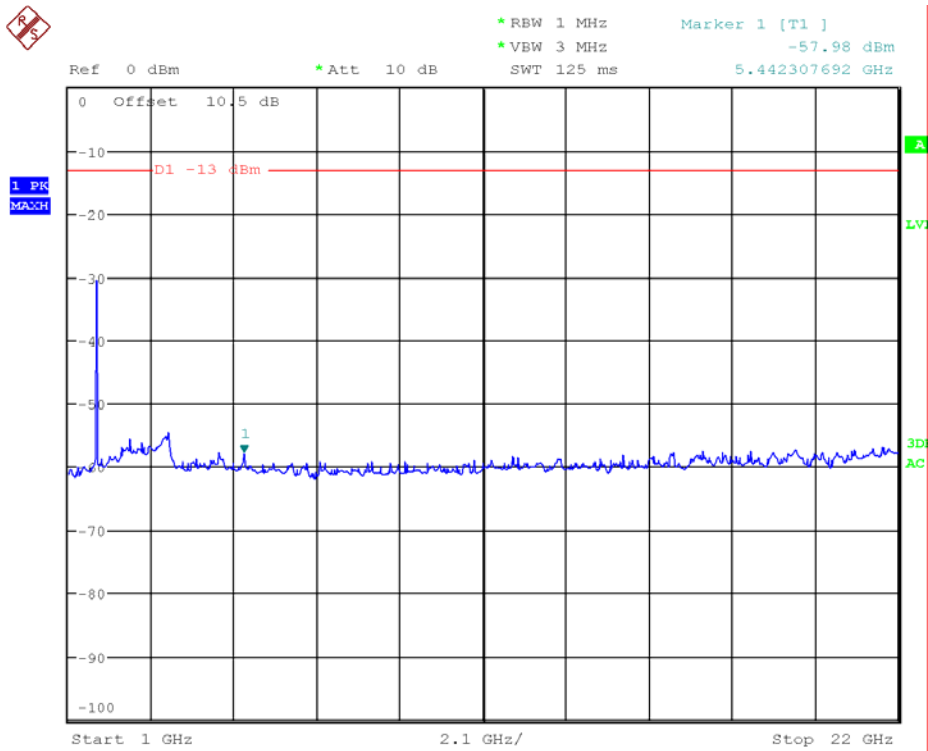

2100MHz –LTE-5M uplink (middle frequency) 30MHz-1GHz

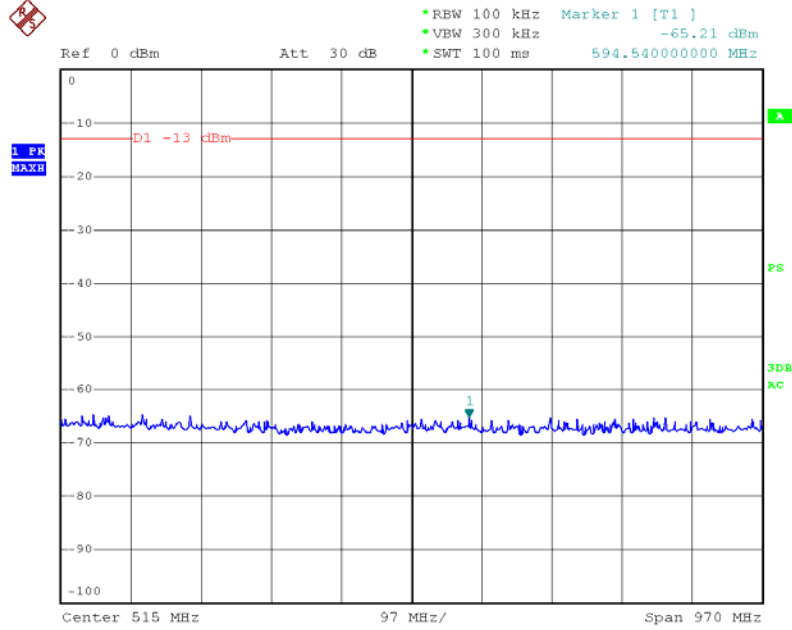

2100MHz –LTE-5M uplink(middle frequency) Above 1GHz

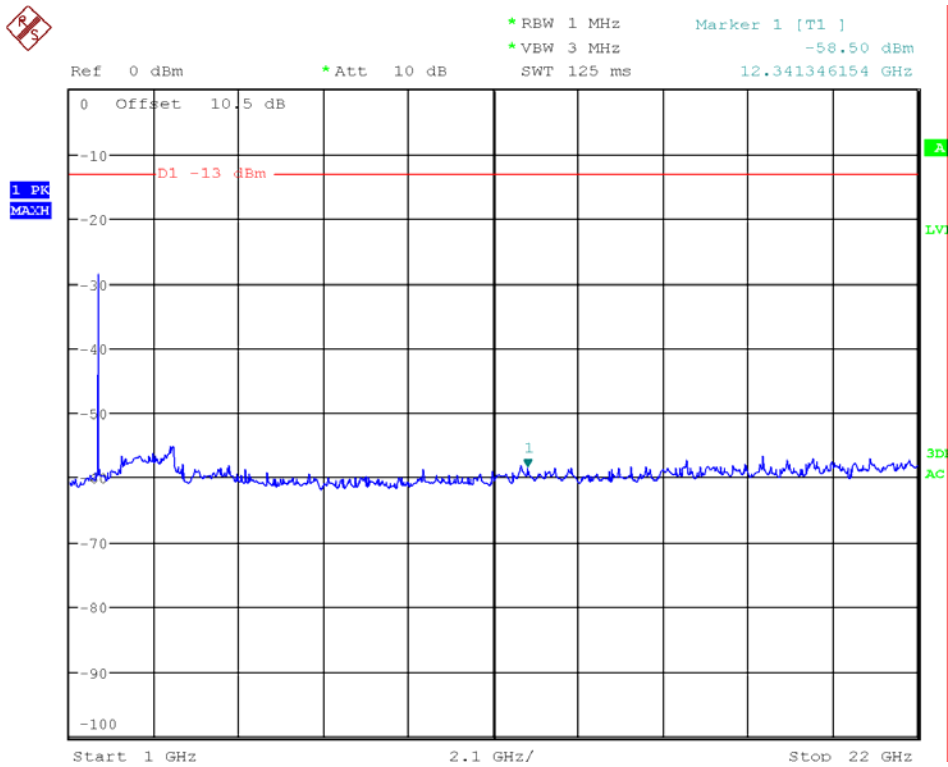

2100MHz –LTE-5M uplink (highest frequency) 30MHz-1GHz

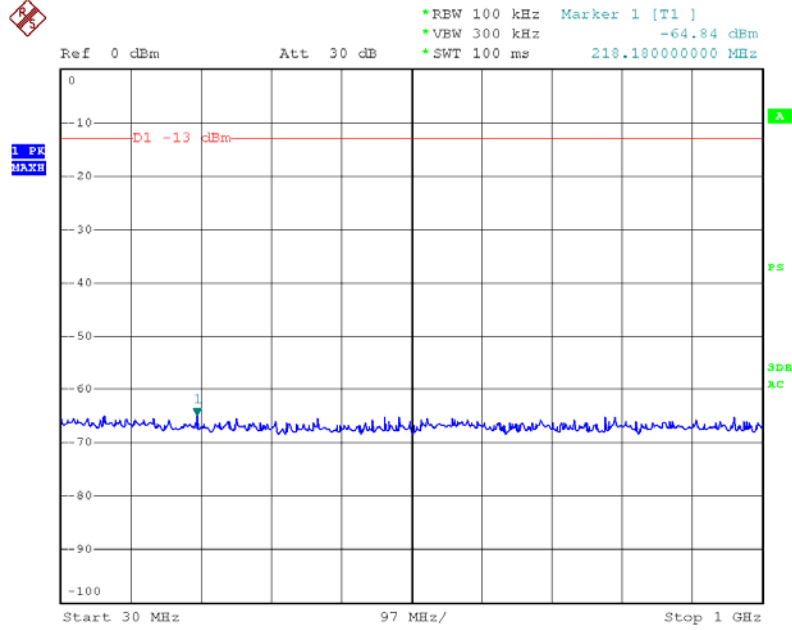

2100MHz –LTE-5M uplink (highest frequency) Above 1GHz

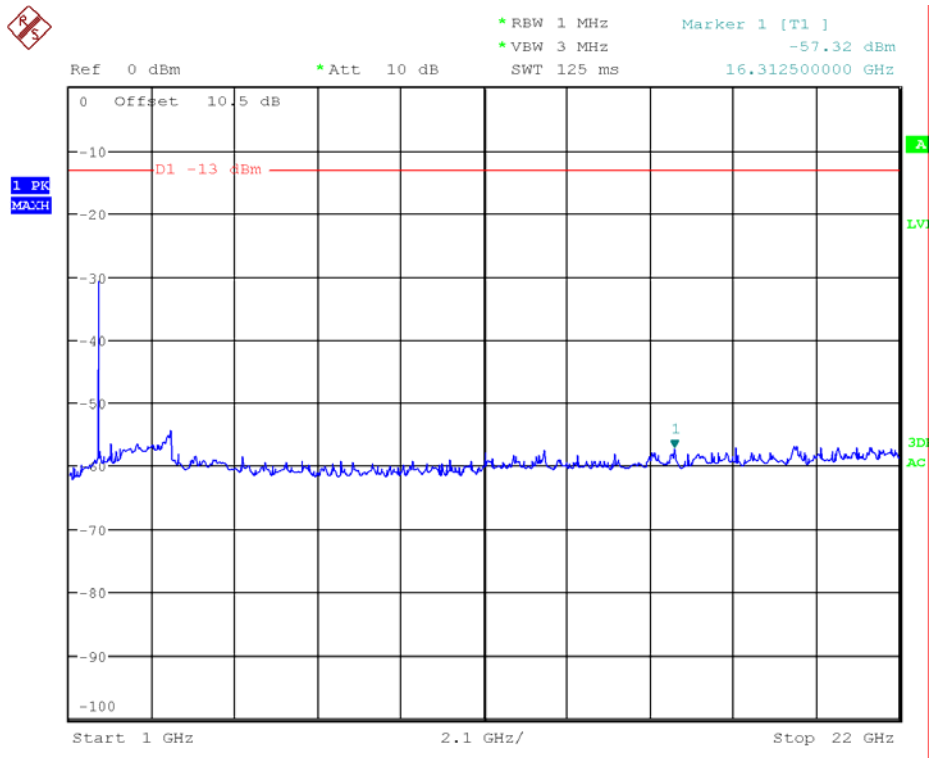

2100MHz –LTE-10M downlink (lowest frequency)30MHz-1GHz

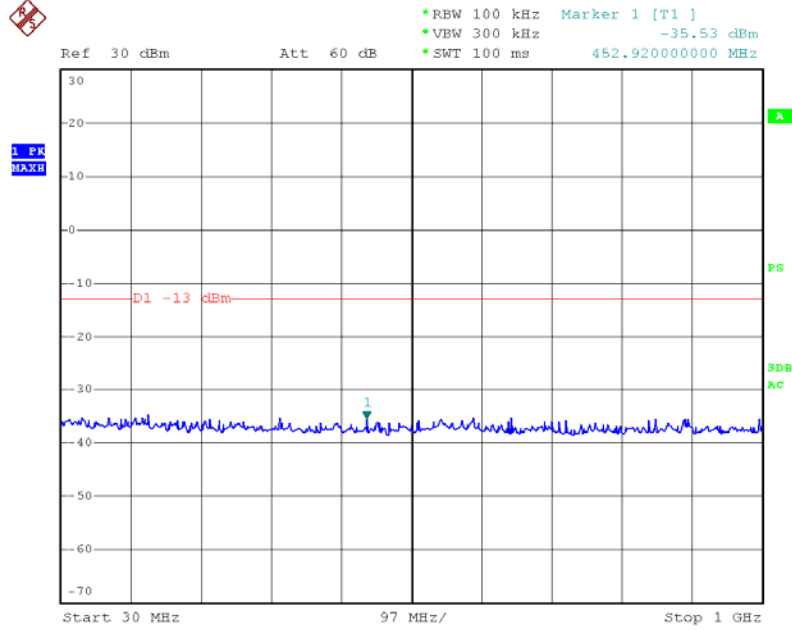

2100MHz –LTE-10M downlink (lowest frequency) Above 1GHz

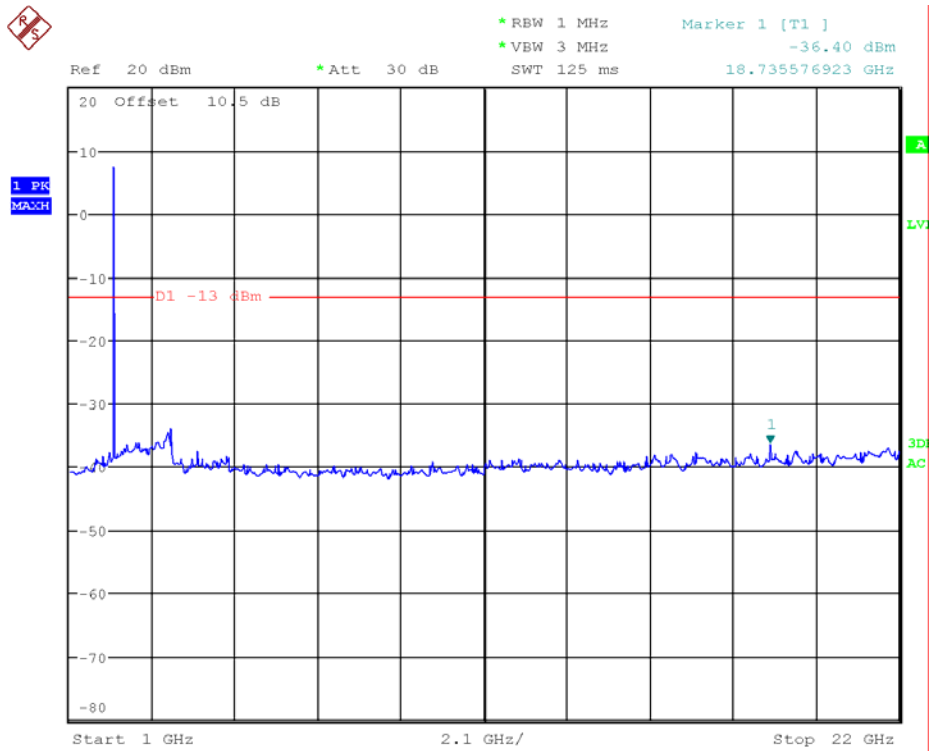

2100MHz –LTE-10M downlink (middle frequency)30MHz-1GHz

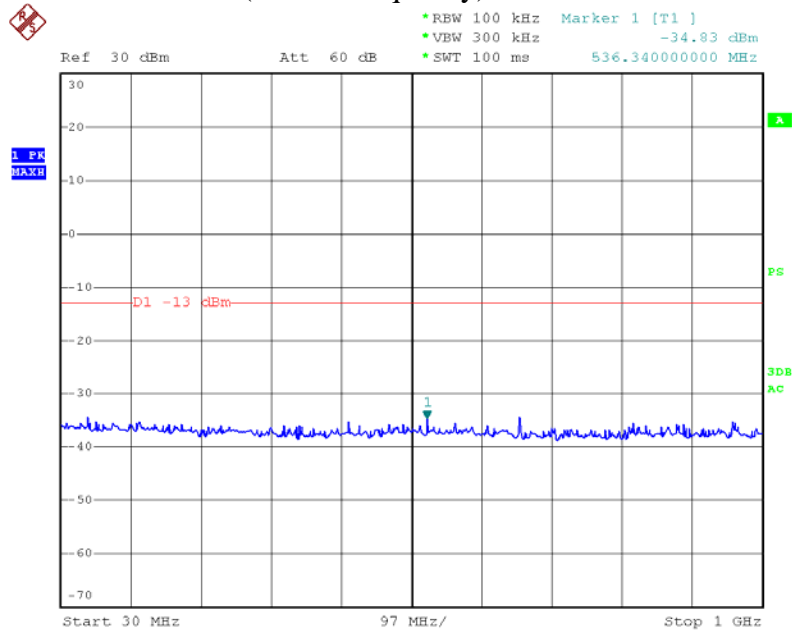

2100MHz –LTE-10M downlink (middle frequency) Above 1GHz

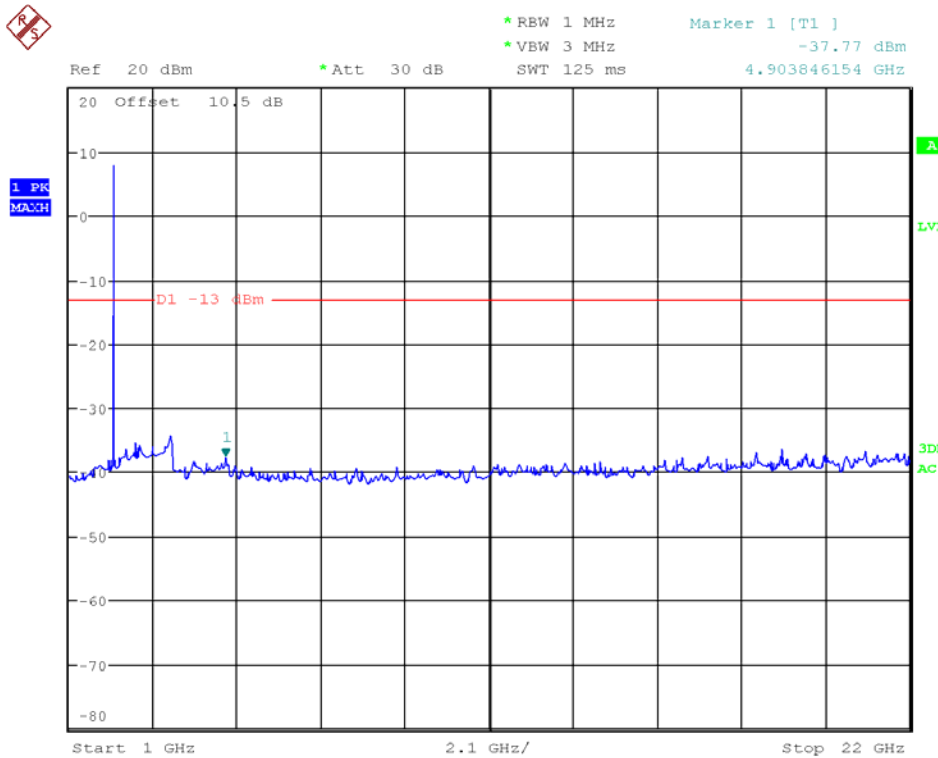

2100MHz –LTE-10M downlink (highest frequency)30MHz-1GHz

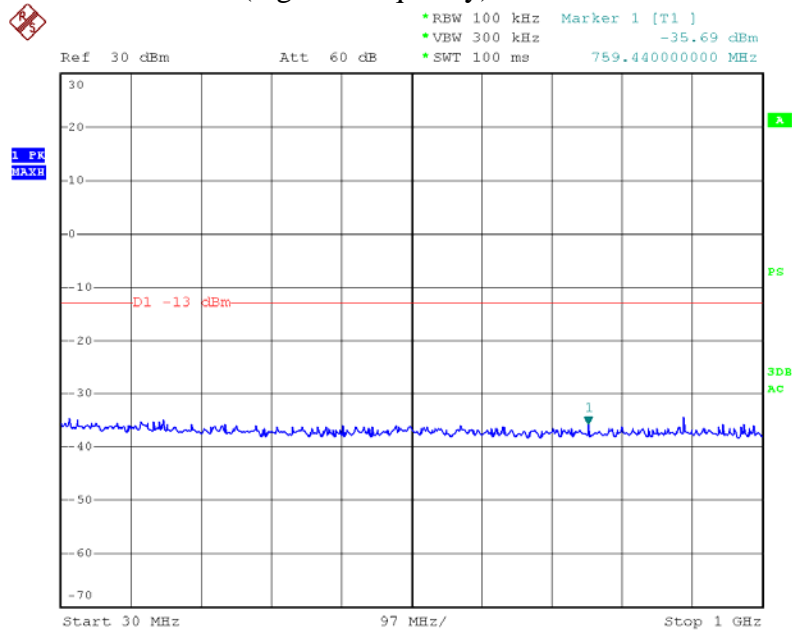

2100MHz –LTE-10M downlink (highest frequency) Above 1GHz

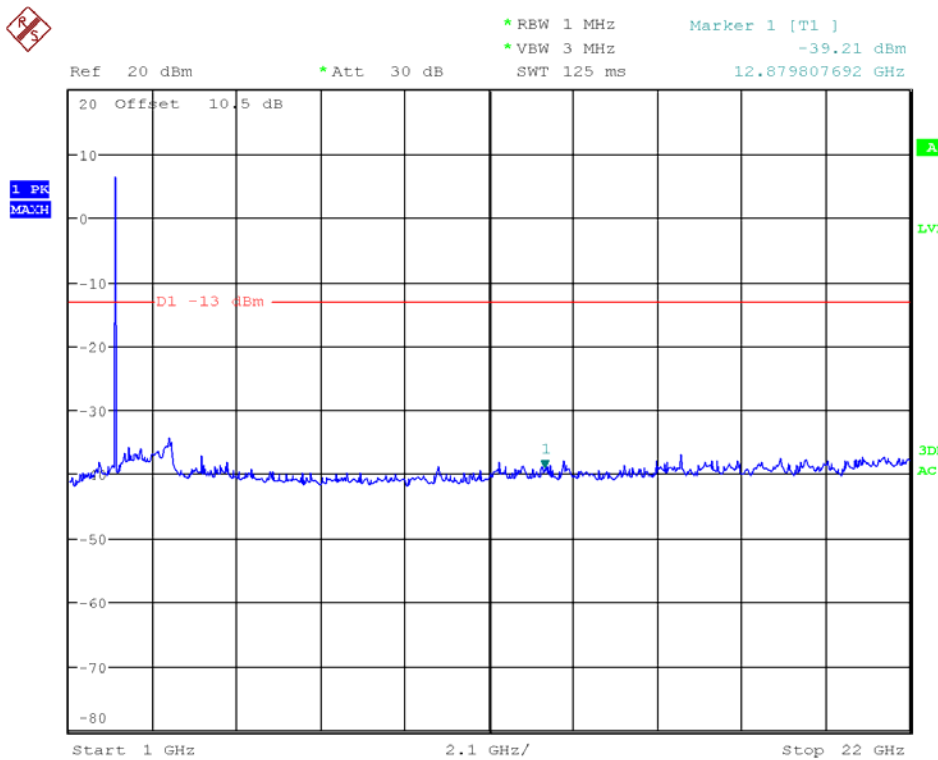

2100MHz –LTE-10M uplink (lowest frequency) 30MHz-1GHz

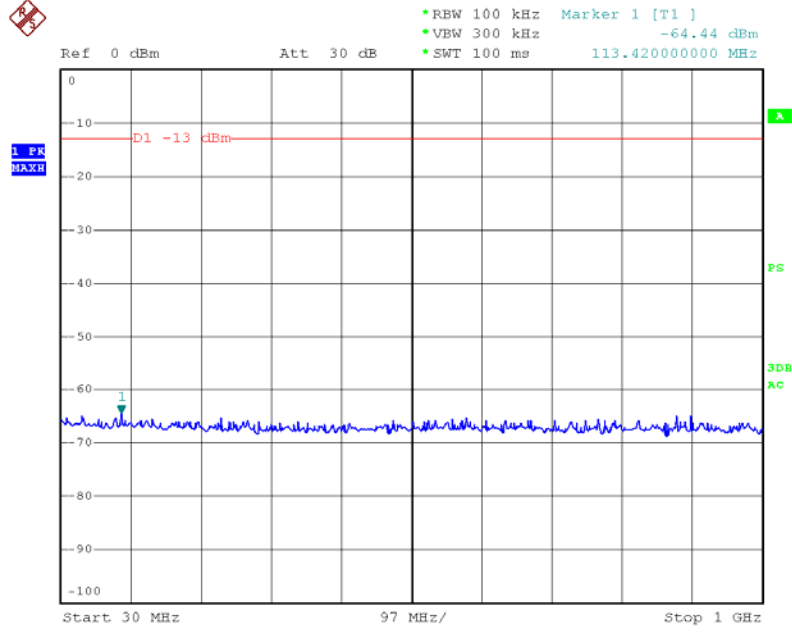

2100MHz –LTE-10M uplink (lowest frequency) Above 1GHz

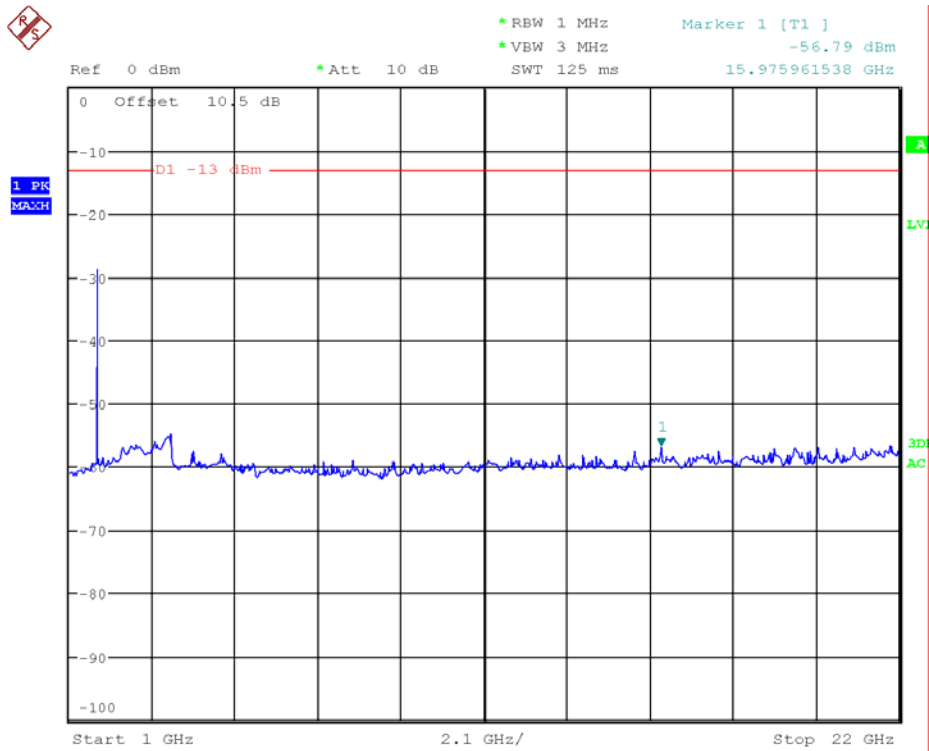

2100MHz –LTE-10M uplink (middle frequency) 30MHz-1GHz

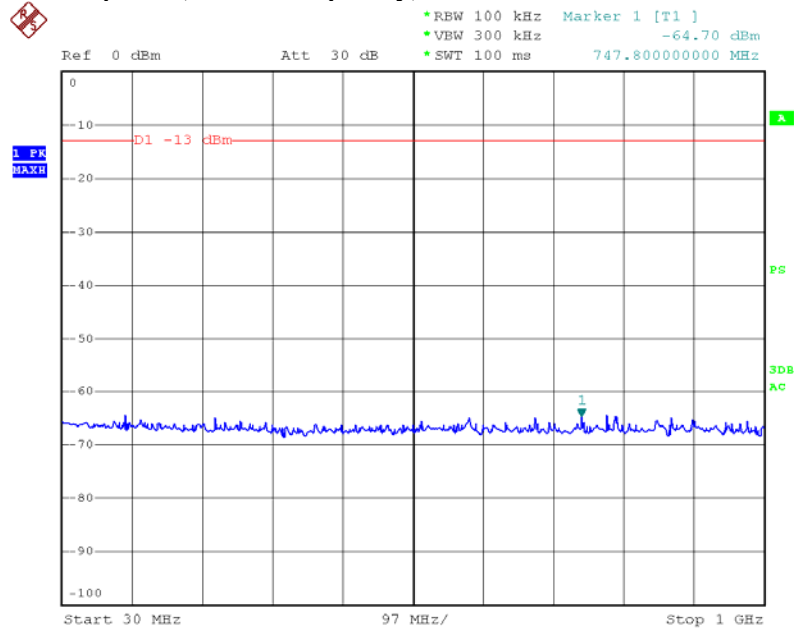

2100MHz –LTE-10M uplink(middle frequency) Above 1GHz

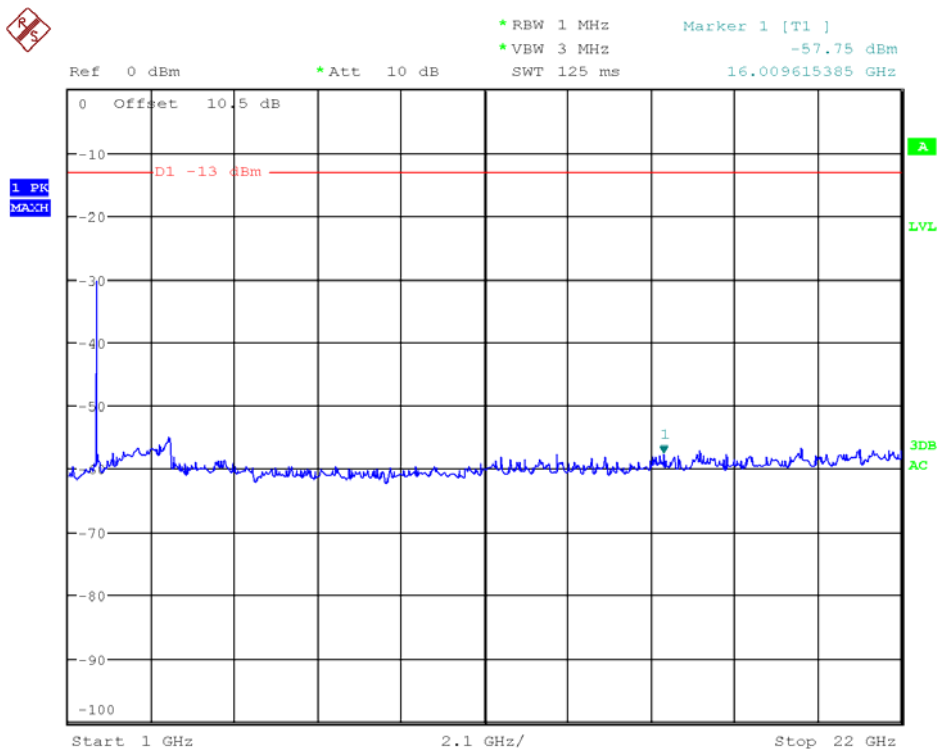

2100MHz –LTE-10M uplink (highest frequency) 30MHz-1GHz

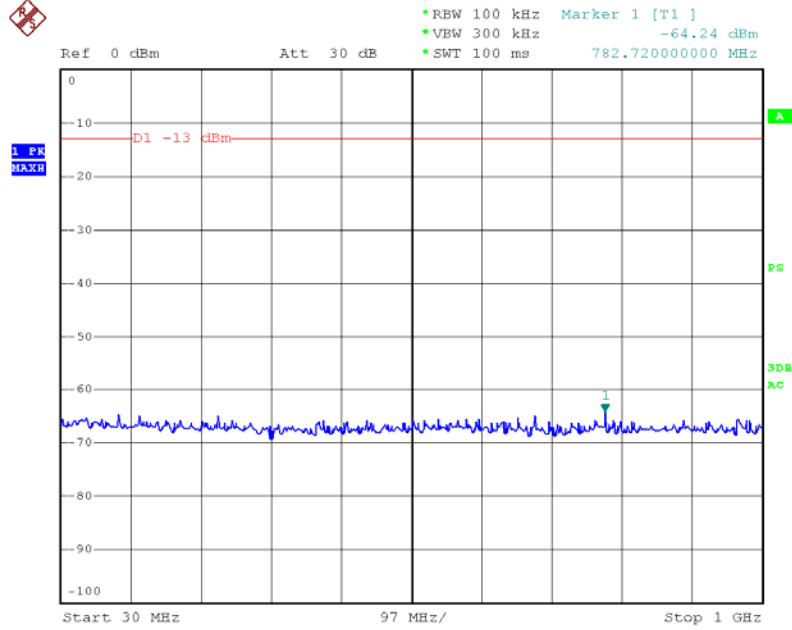

2100MHz –LTE-10M uplink (highest frequency) Above 1GHz

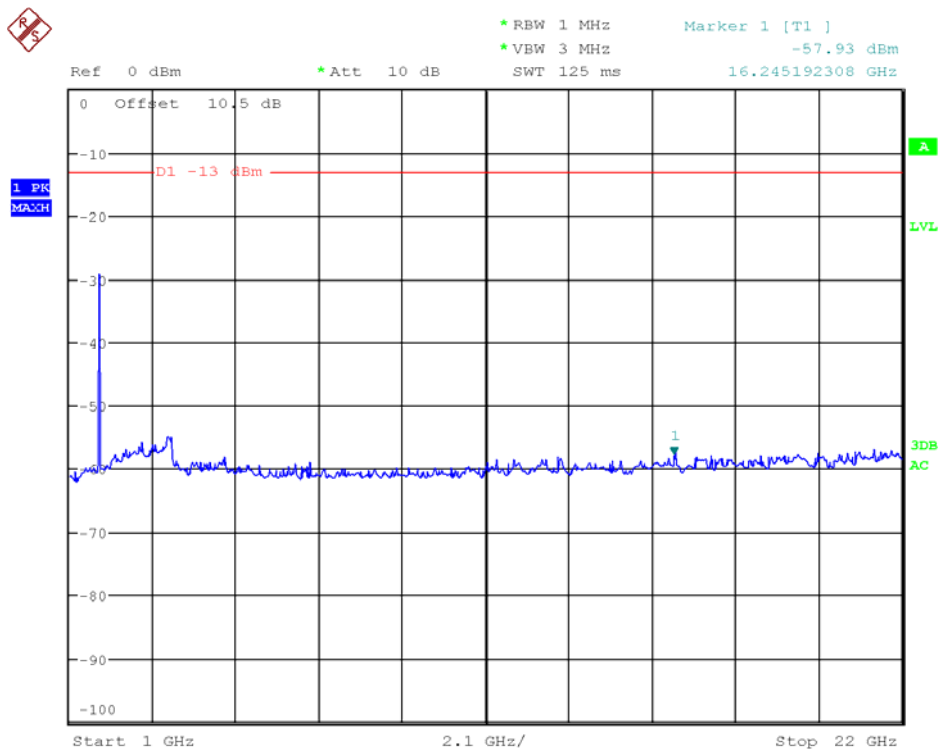

2100MHz –LTE-15M downlink (lowest frequency) 30MHz-1GHz

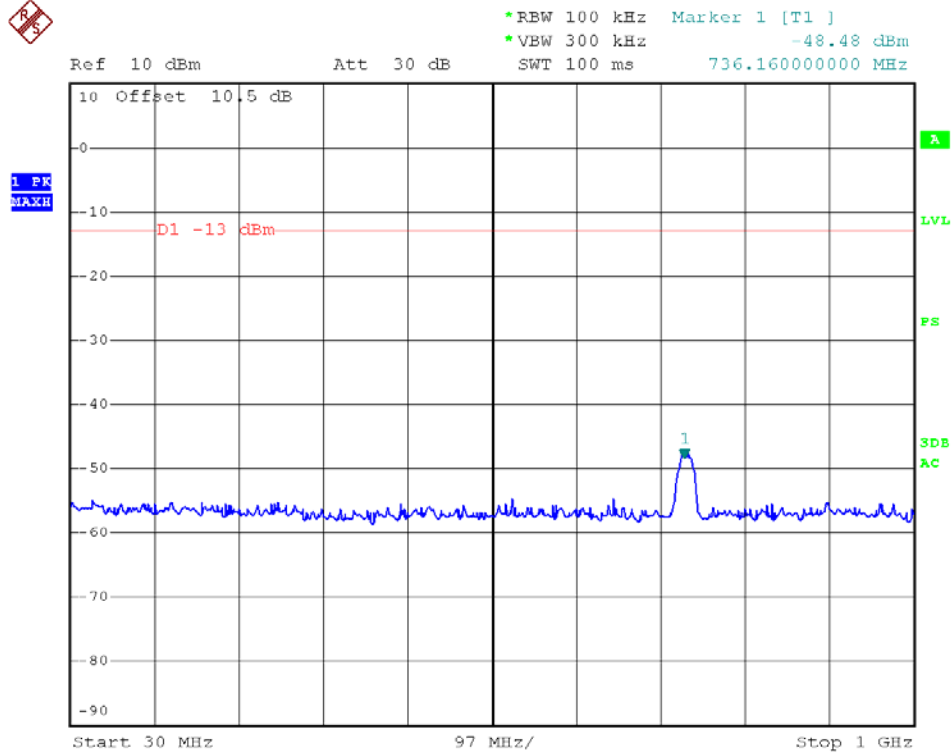

2100MHz –LTE-15M downlink (lowest frequency) Above 1GHz

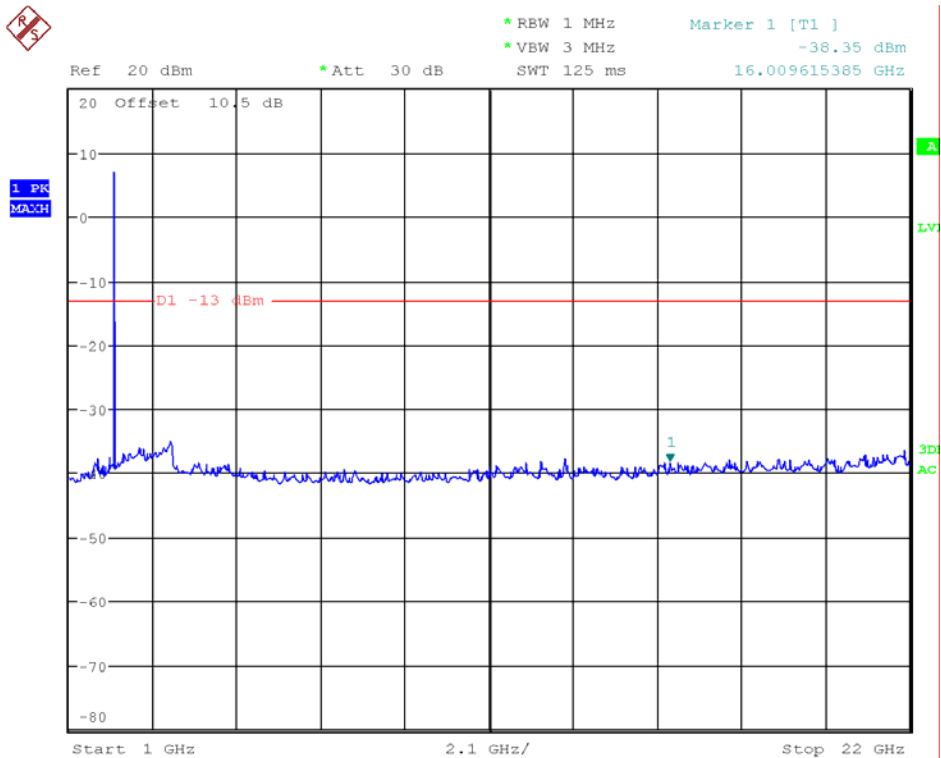

2100MHz -LTE-15M downlink (middle frequency) 30MHz-1GHz

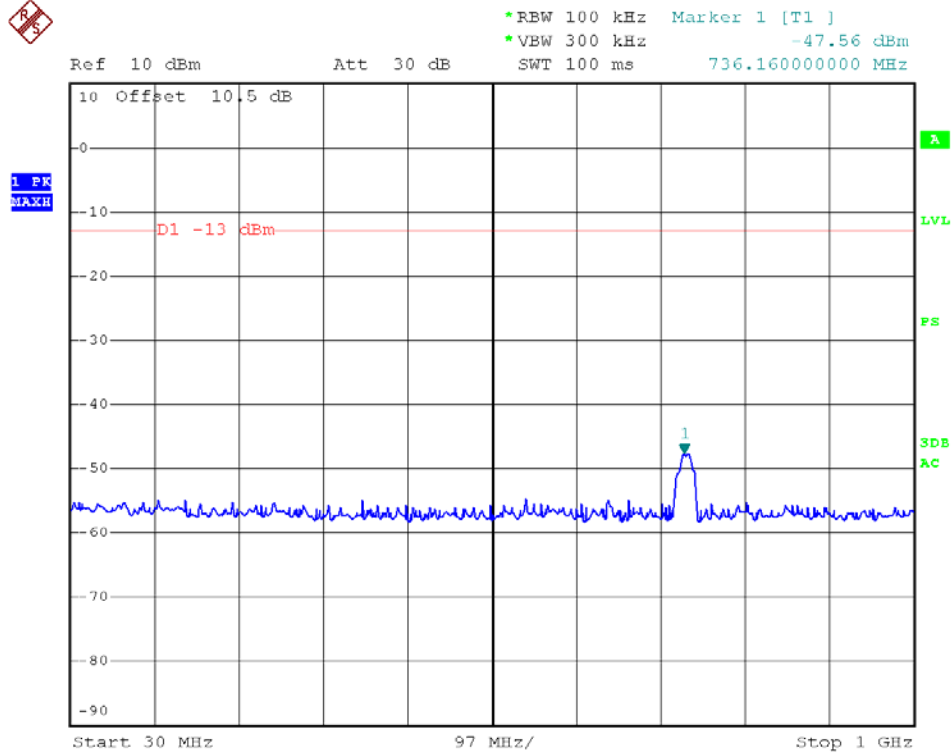

2100MHz -LTE-15M downlink (middle frequency) Above 1GHz

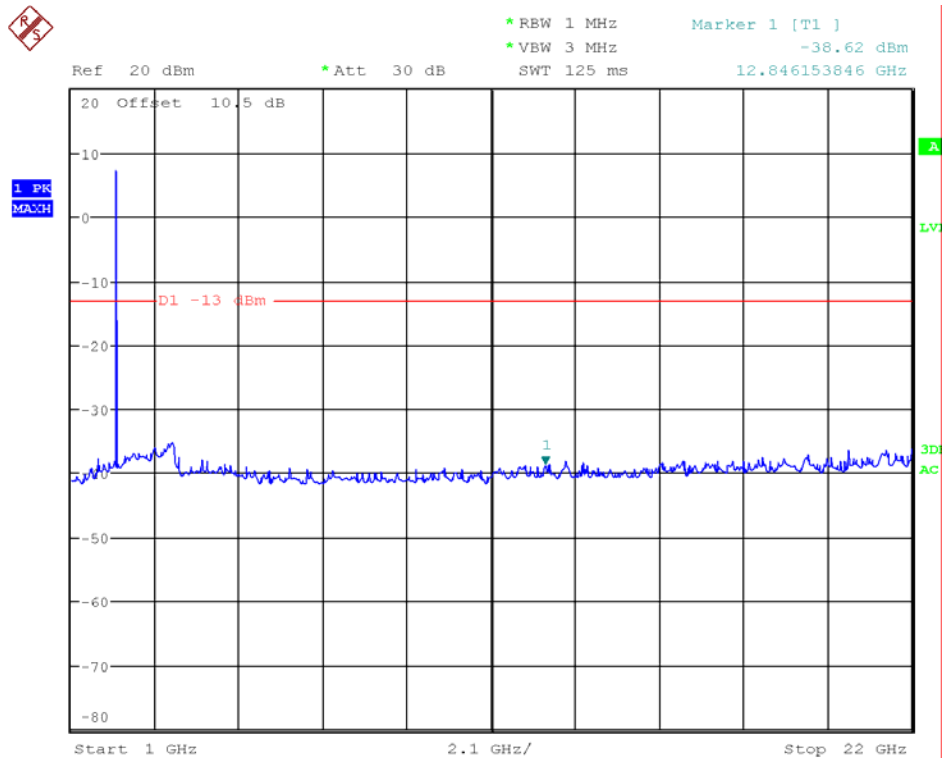

2100MHz –LTE-15M downlink (highest frequency) 30MHz-1GHz

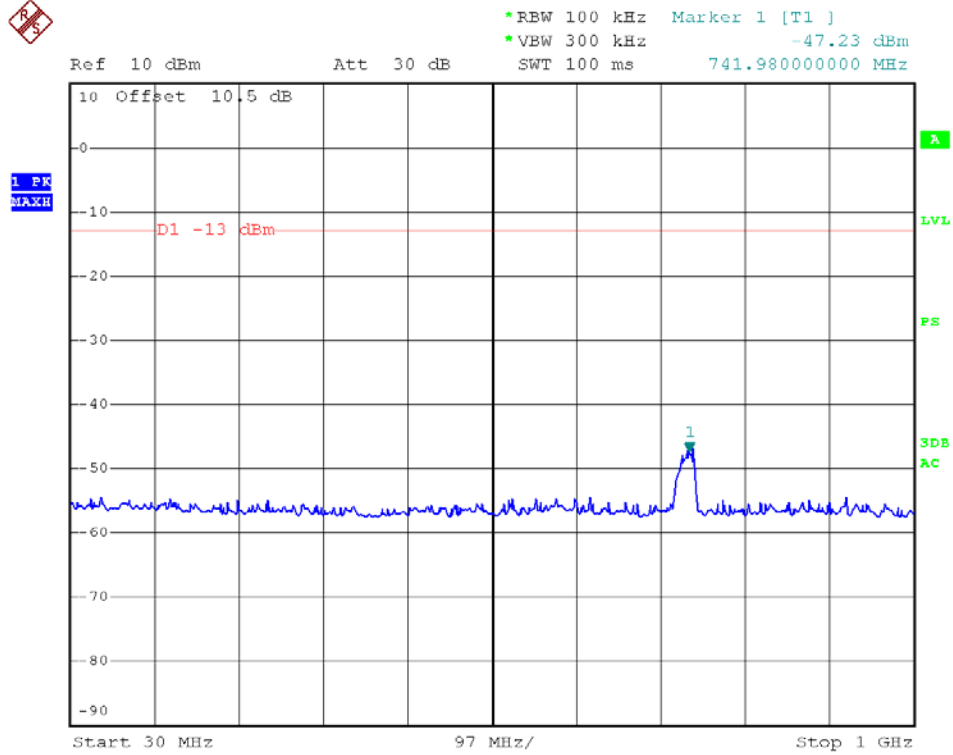

2100MHz –LTE-15M downlink (highest frequency) Above 1GHz

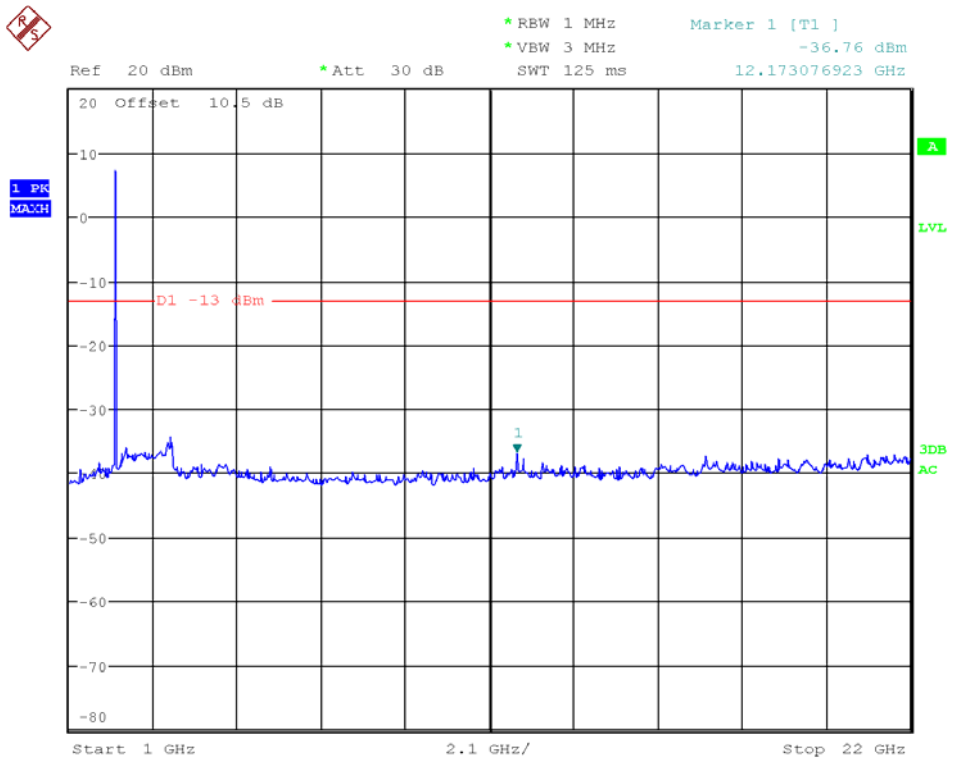

2100MHz –LTE-15M uplink (lowest frequency) 30MHz-1GHz

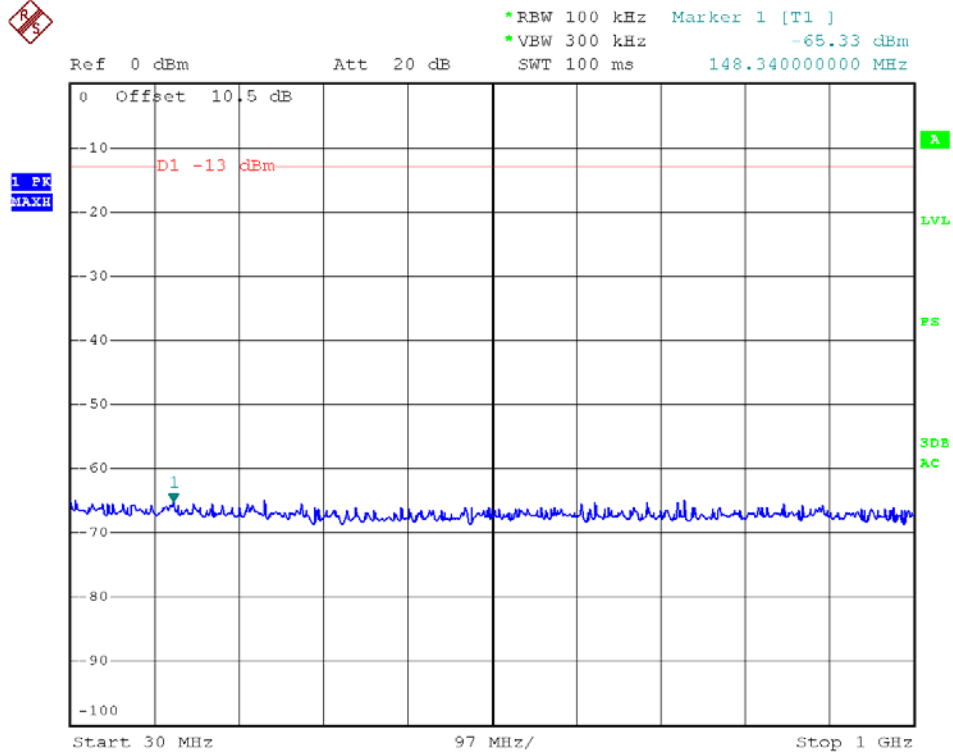

2100MHz –LTE-15M uplink (lowest frequency) Above 1GHz

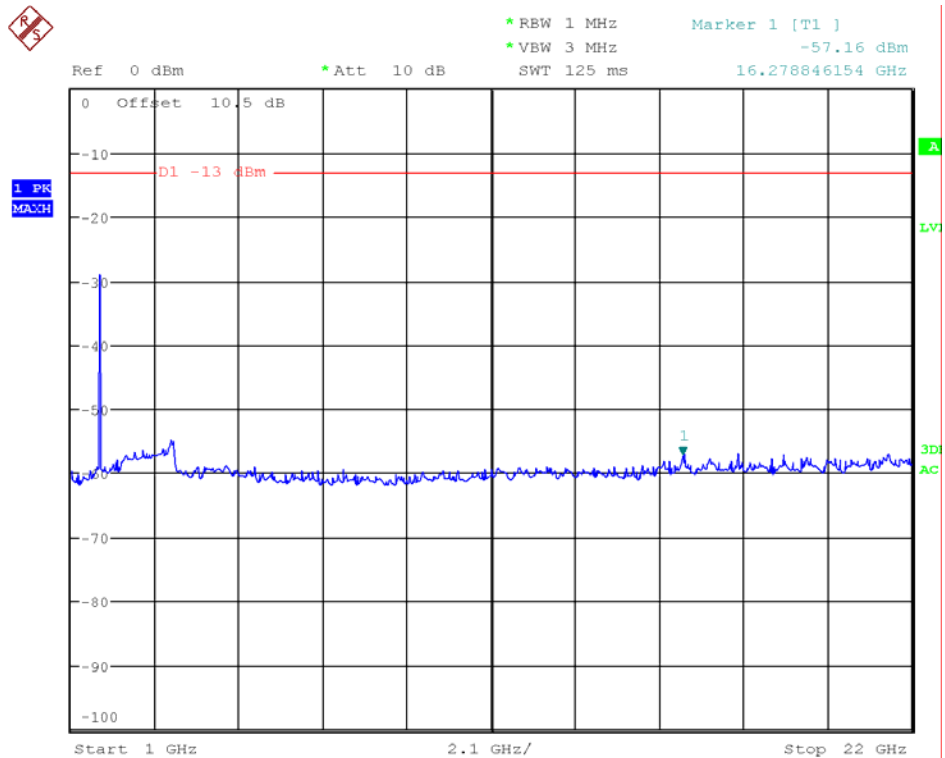

2100MHz -LTE-15M uplink (middle frequency) 30MHz-1GHz

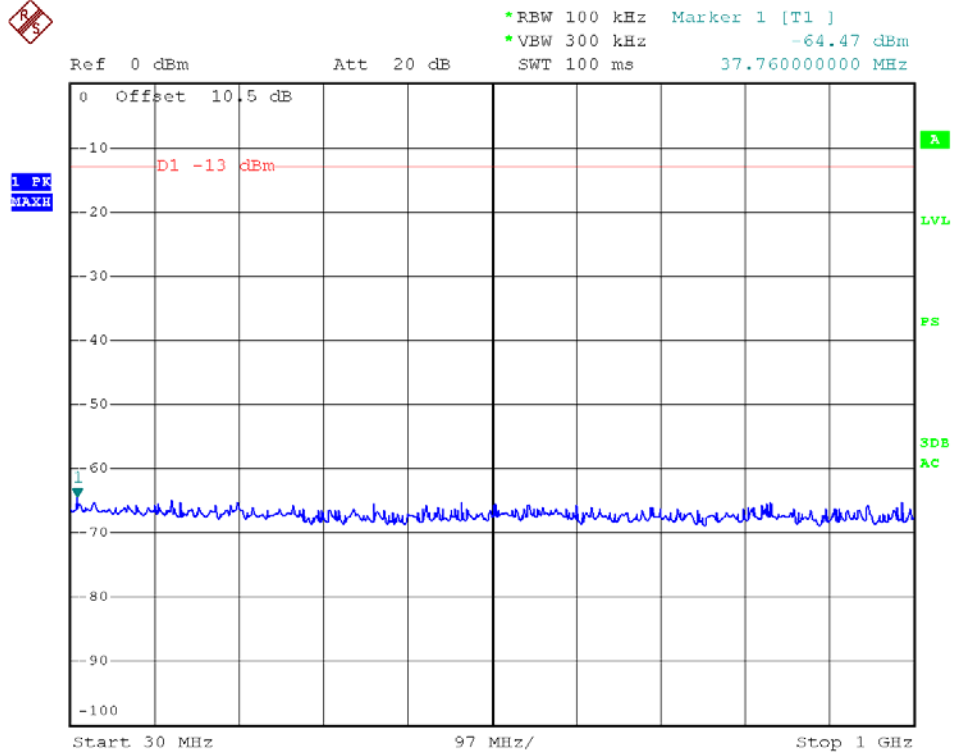

2100MHz -LTE-15M uplink(middle frequency) Above 1GHz

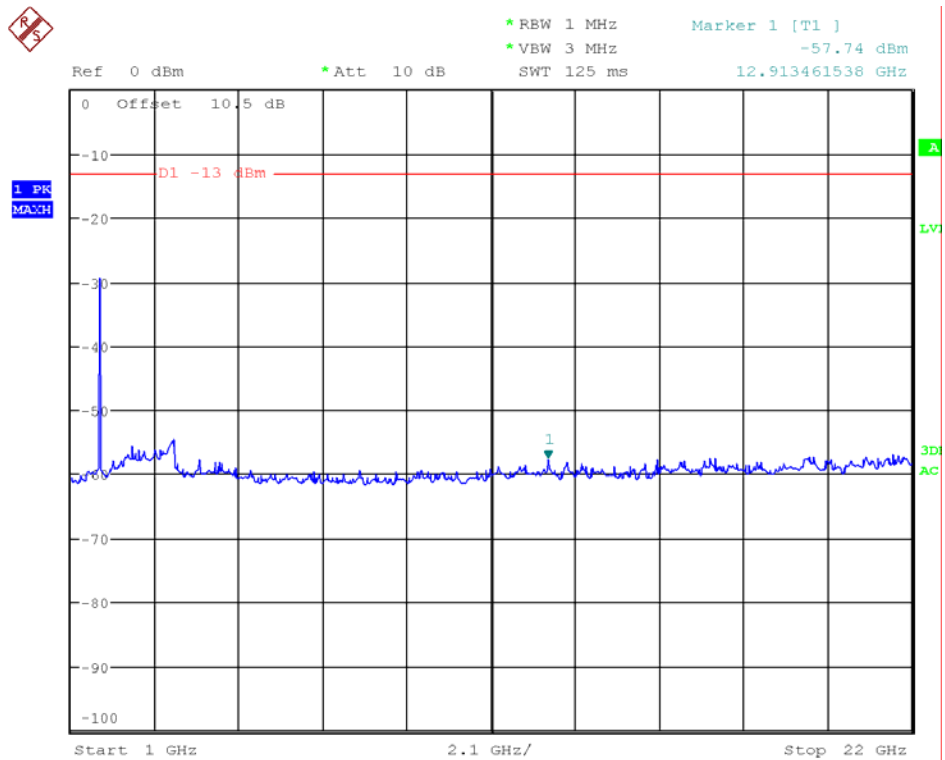

2100MHz -LTE-15M uplink (highest frequency) 30MHz-1GHz

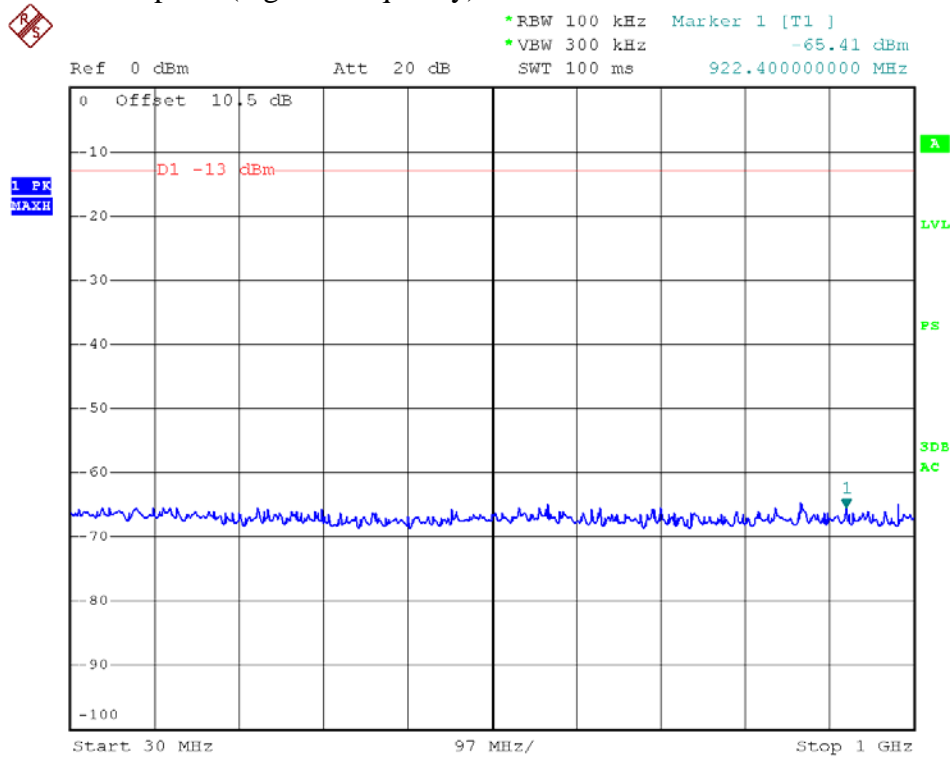

2100MHz -LTE-15M uplink (highest frequency) Above 1GHz

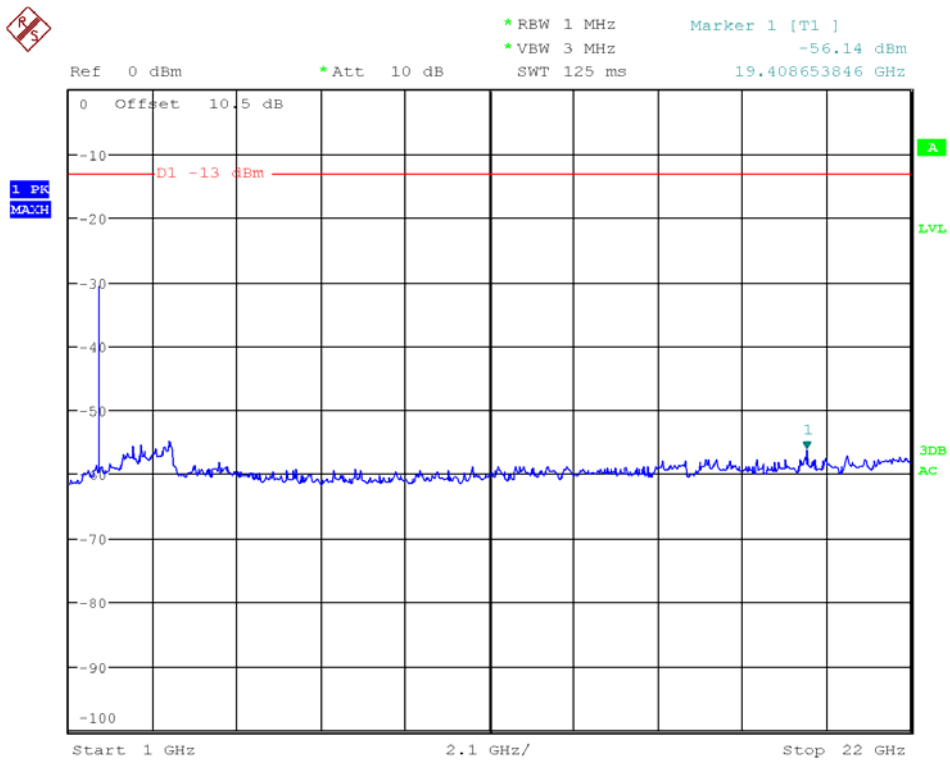

2100MHz –WCDMA downlink (lowest frequency) 30MHz-1GHz

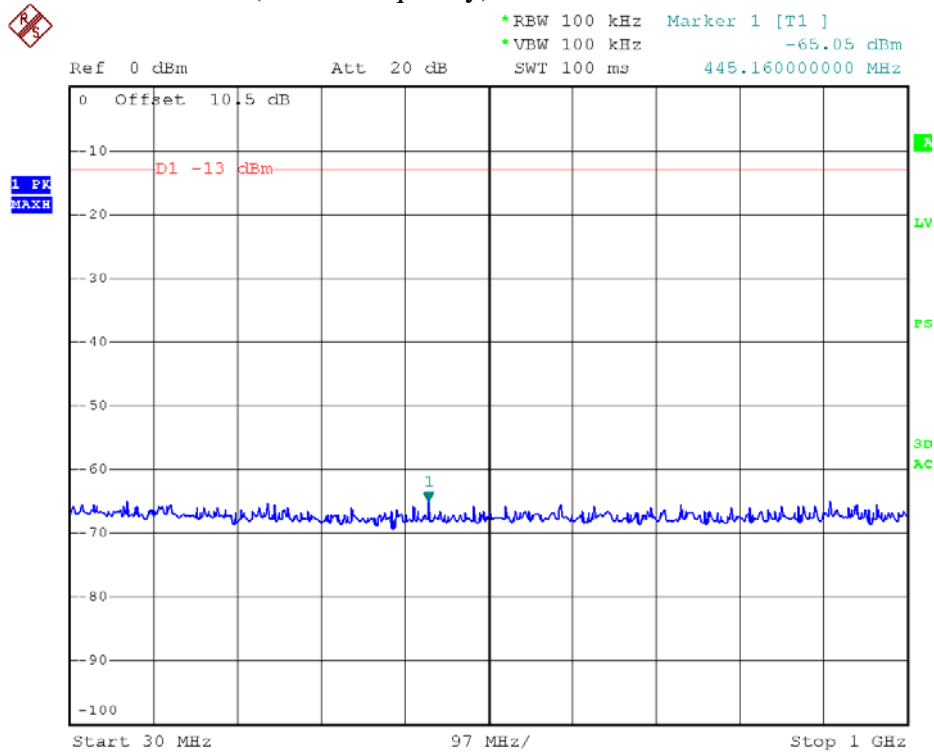

2100MHz –WCDMA downlink (lowest frequency) Above 1GHz

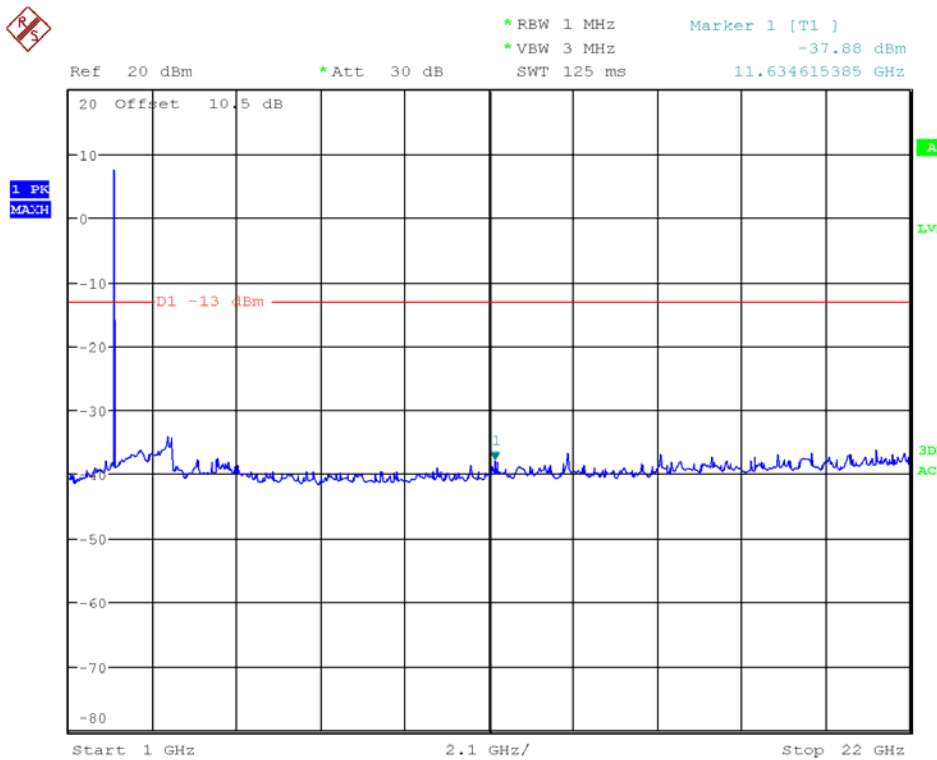

2100MHz –WCDMA downlink (middle frequency) 30MHz-1GHz

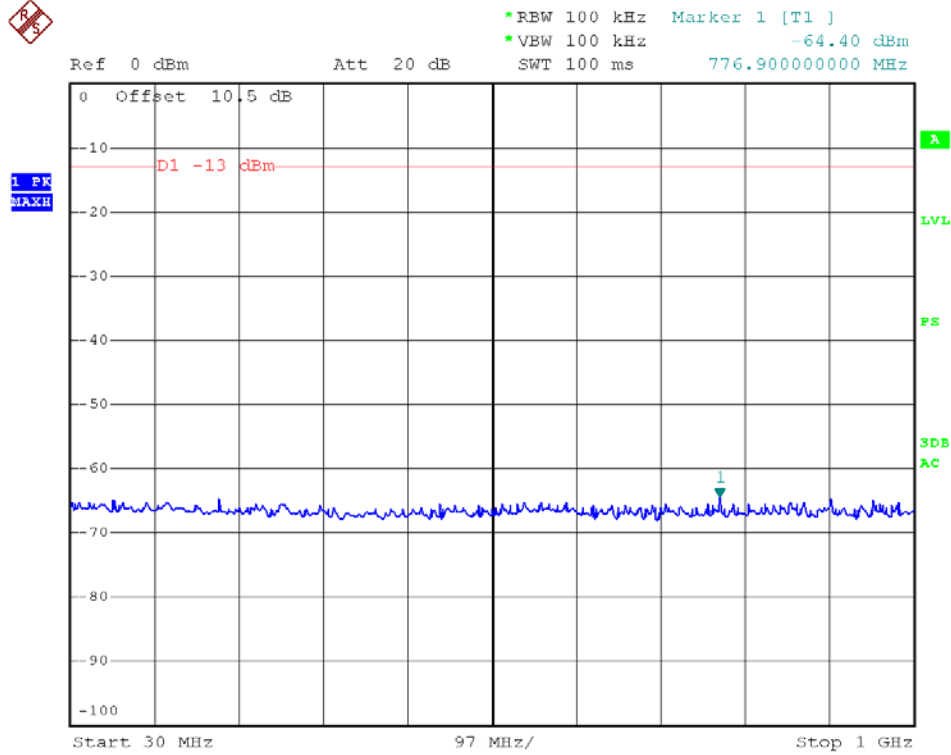

2100MHz –WCDMA downlink (middle frequency) Above 1GHz

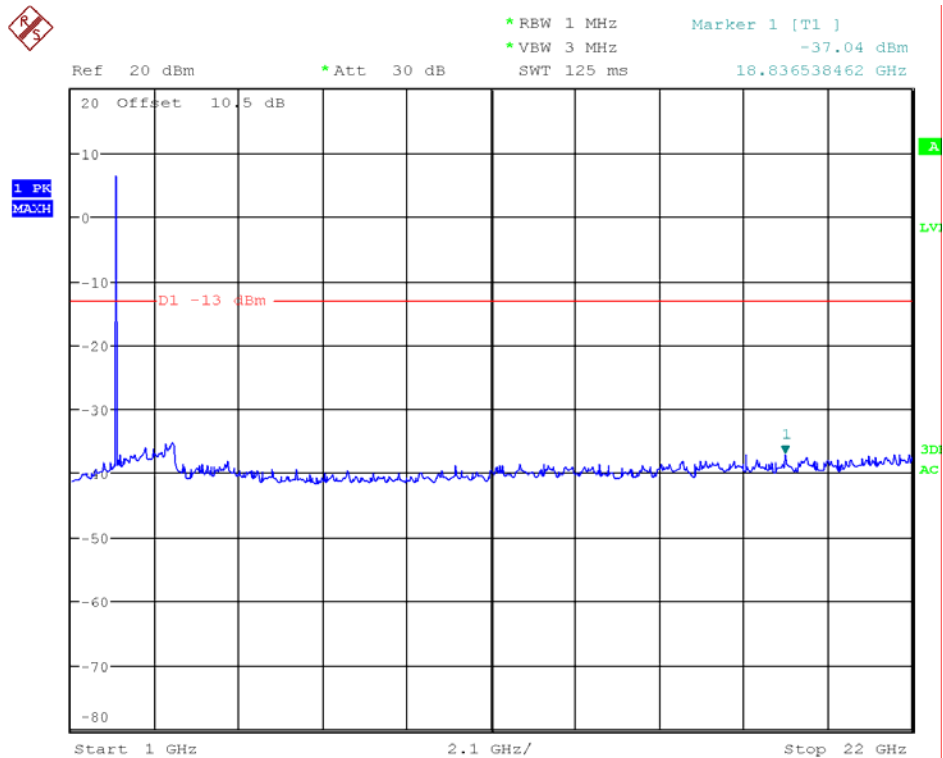

2100MHz –WCDMA downlink (high frequency) 30MHz-1GHz

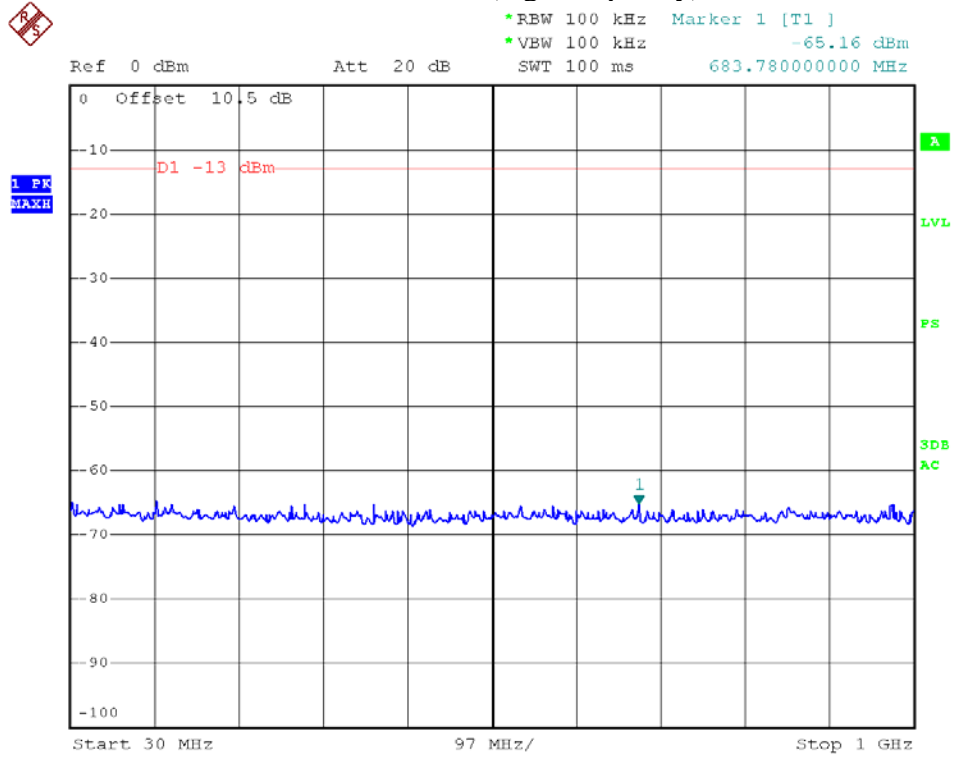

2100MHz –WCDMA downlink (high frequency) Above 1GHz

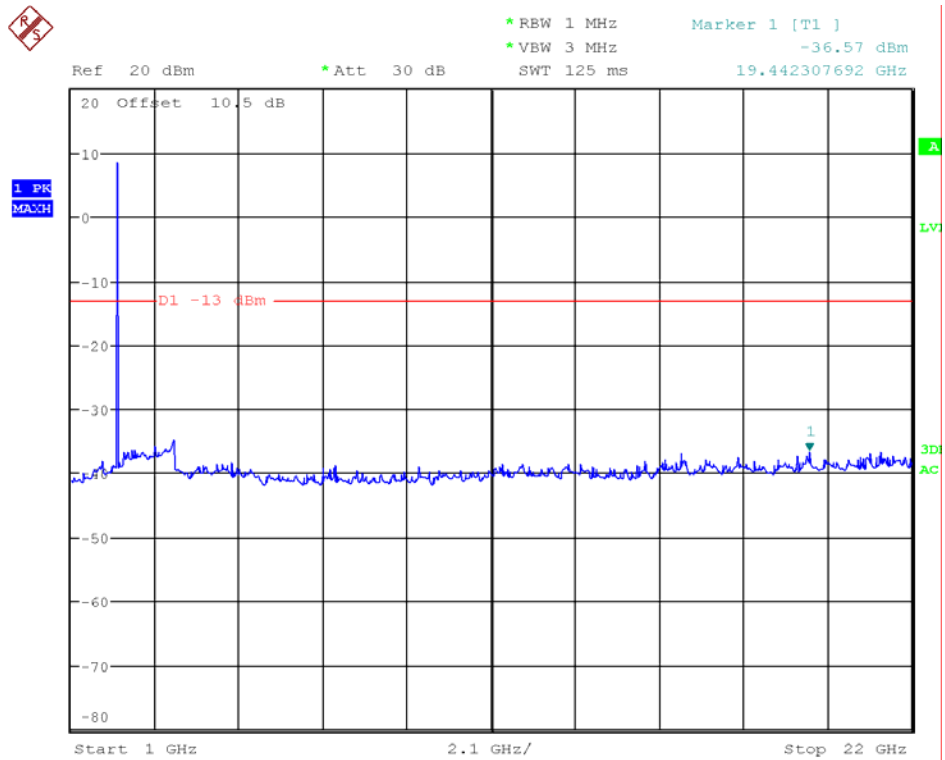

2100MHz –WCDMA uplink (lowest frequency) 30MHz-1GHz

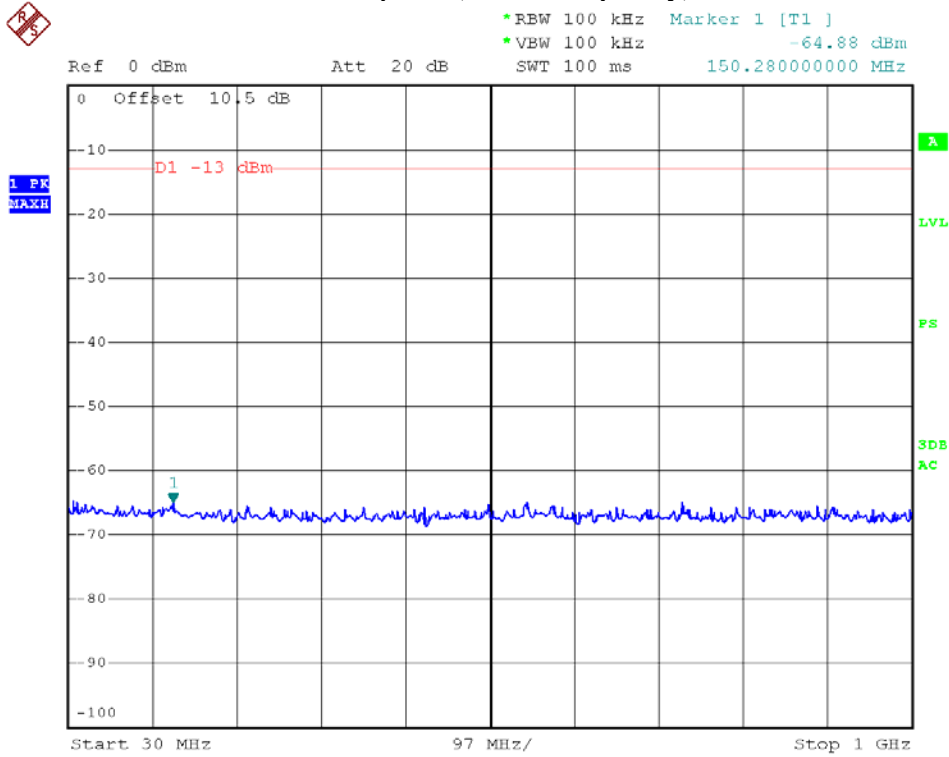

2100MHz –WCDMA uplink (lowest frequency) Above 1GHz

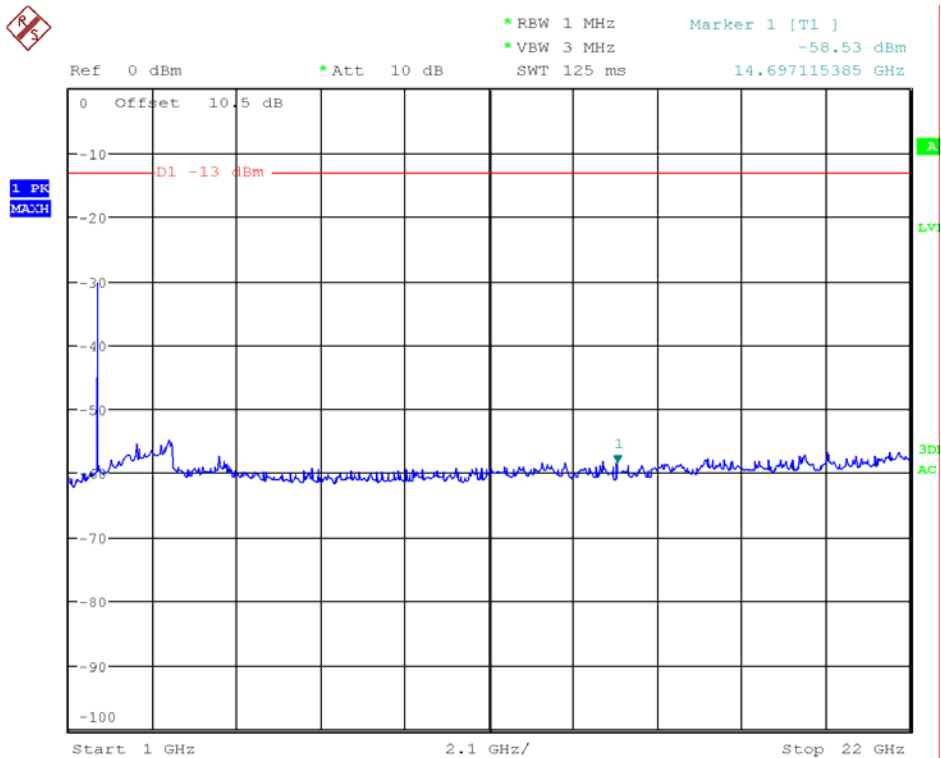

2100MHz –WCDMA uplink (middle frequency) 30MHz-1GHz

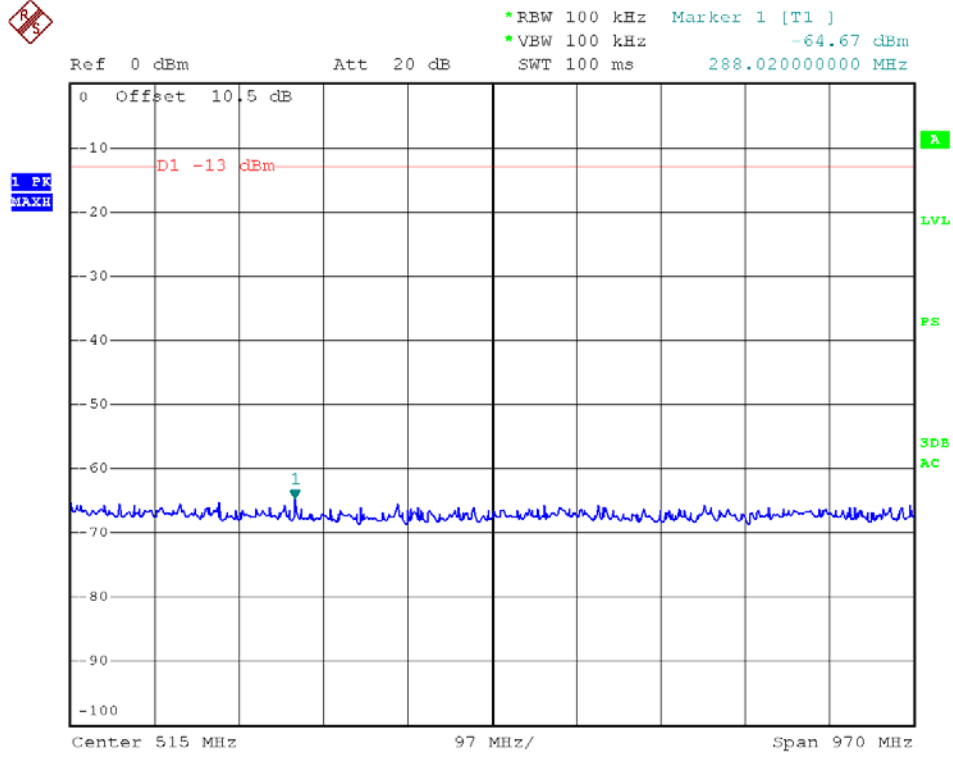

2100MHz –WCDMA uplink (middle frequency) Above 1GHz

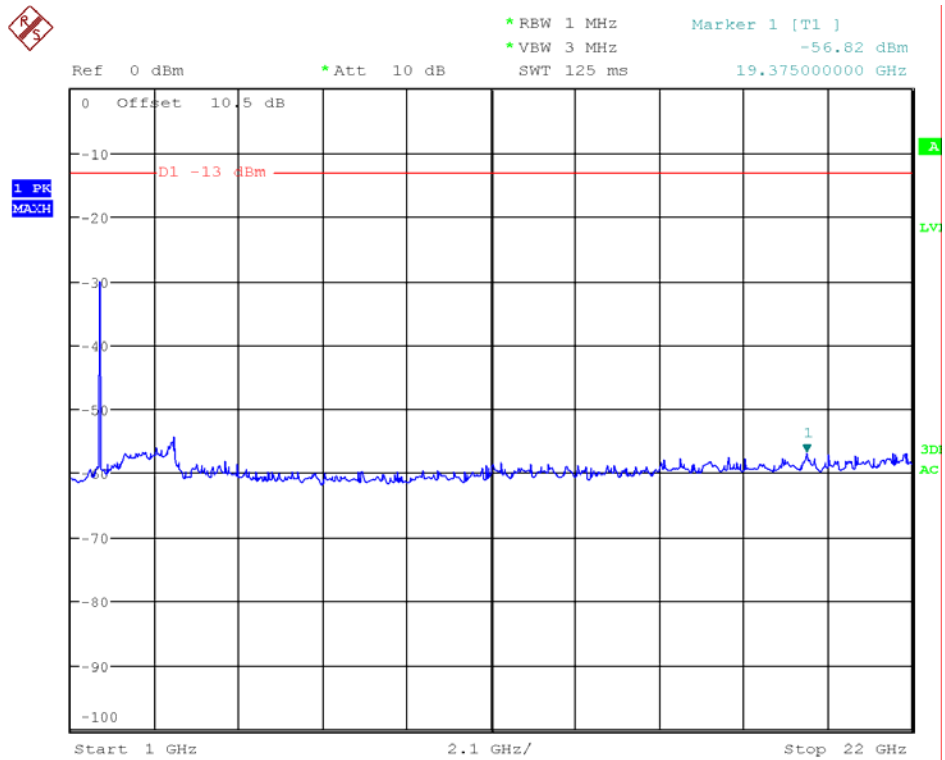

2100MHz –WCDMA uplink (high frequency) 30MHz-1GHz

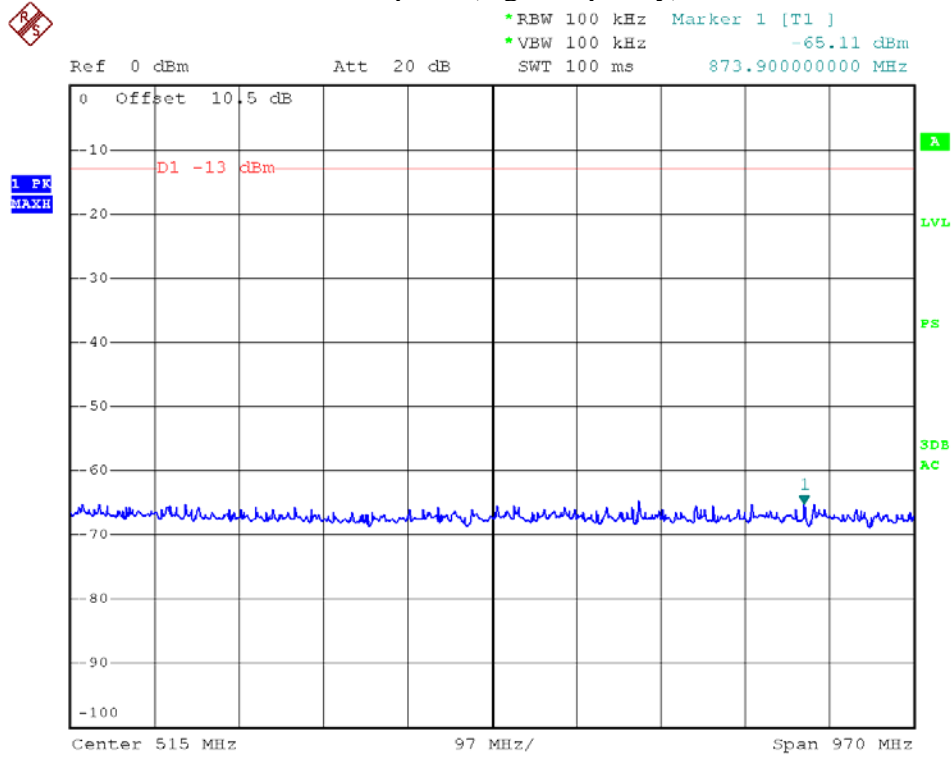

2100MHz –WCDMA uplink (high frequency) Above 1GHz

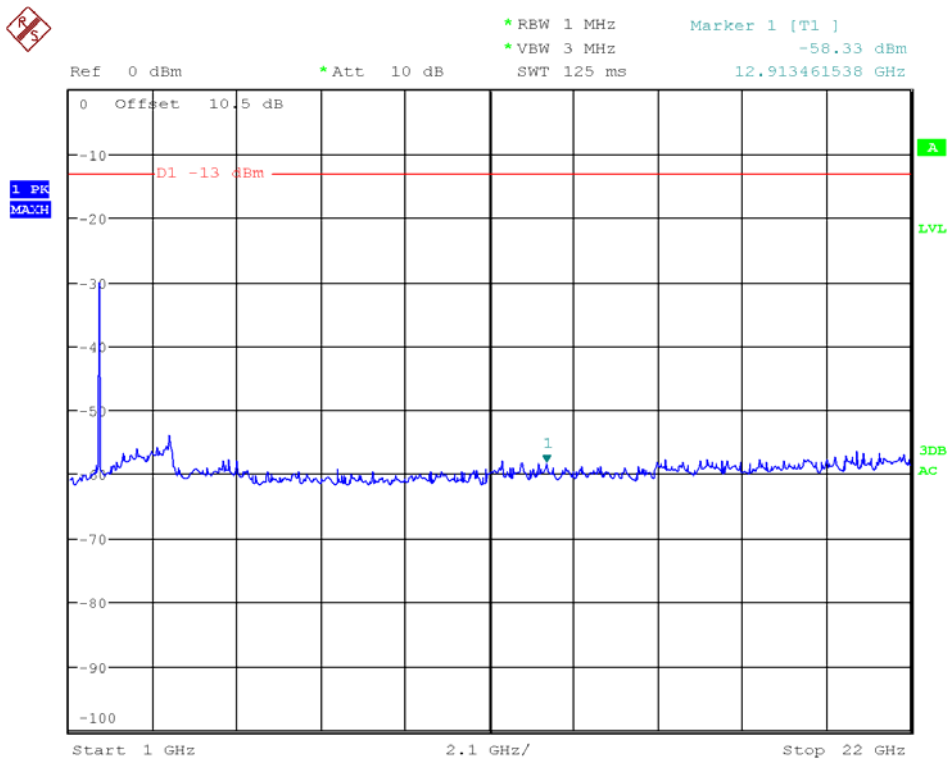

4.2.3 BAND EDGE

Test Date: 10 November, 2012

Test Method: FCC part 2.1051

Test Requirement: FCC 27.53: The power of any emission outside of the authorized operating frequency ranges must be attenuated below the transmitting power (P) by a factor of at least $43 + 10\log(P)$ dB, or -13dBm.

Status: The output power of EUT be set to maximum value, the gain of EUT be set to maximum value by software through the manufacture

Conditions: Normal

Test configuration

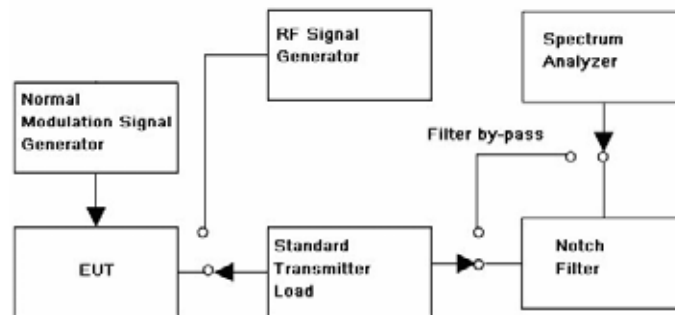

Test Procedure:

Conducted Emission test procedure:

- a) Connect the equipment as illustrated, when the output power is over the max value of the Spectrum Analyzer, add the attenuator to avoid destroying the facility.
- b) Set the center frequency of the Spectrum Analyzer to the assigned transmitter frequency, key the transmitter, and set the level of the carrier to the full scale reference line.
- c) Do not apply any tone to modulate the EUT
- d) Adjust the Spectrum Analyzer for the following setting :
 - 1) Resolution Bandwidth, (base the standard, apply the different set). here is 100KHZ for frequency band less than 1GHZ, 1MHz for frequency over 1GHZ;
 - 2) Video Bandwidth refer to standard requirement
- e) Adjust the center frequency of the spectrum analyzer for incremental coverage of the range from:

Use spectrum analyzer channel power measurement

 - 1) the lowest radio frequency generated in the equipment, it can be 9KHZ base the test method, here select 30MHz as lowest frequency start point;
 - 2) the highest radio frequency shall higher than 10 times of carrier frequency.
- f) Record the frequencies and levels of carrier power

Remark: The notch filter is used for avoid the EUT fundamental carrier output power making the spectrum overload and the harmonic spurious brought it.

When the EUT fundamental carrier is not enough to make the status ,the notch filter could be not used.

4.2.3.1 MEASUREMENT RECORD

700MHz-LT-1.4M Channel Bandwidth-Lower Edge

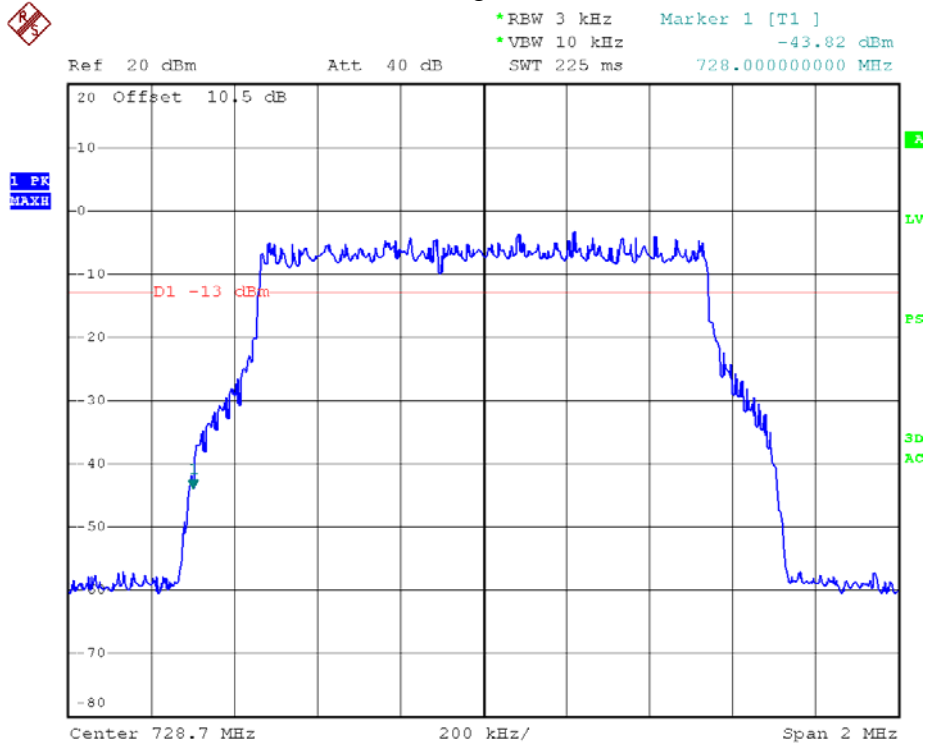

700MHz-LT-1.4M Channel Bandwidth -Upper Edge

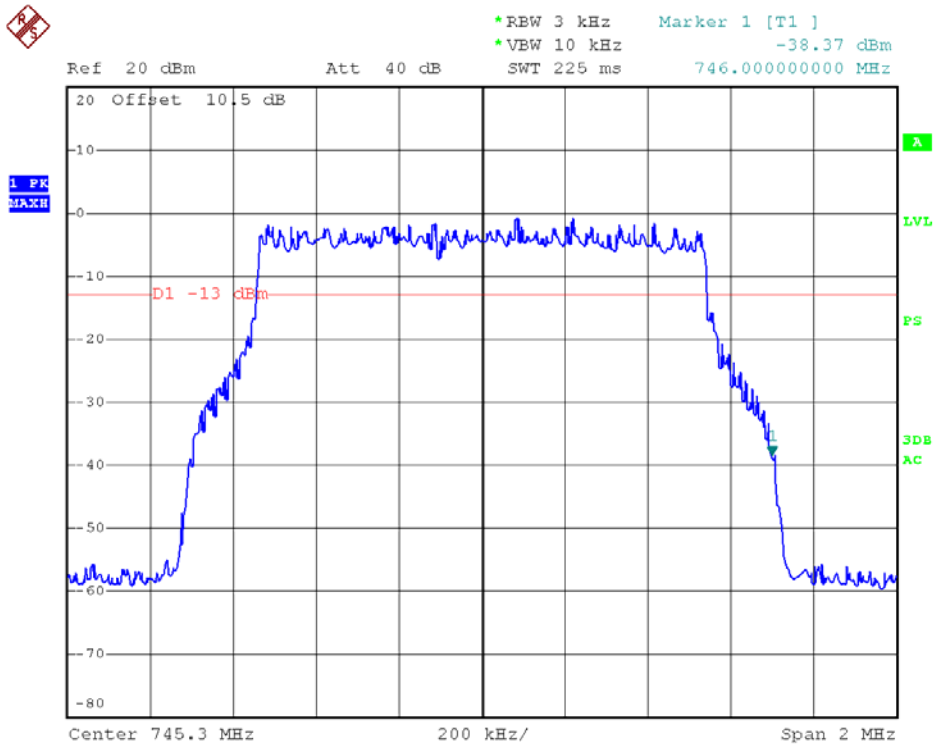

700MHz-LTE-3M Channel Bandwidth -Lower Edge

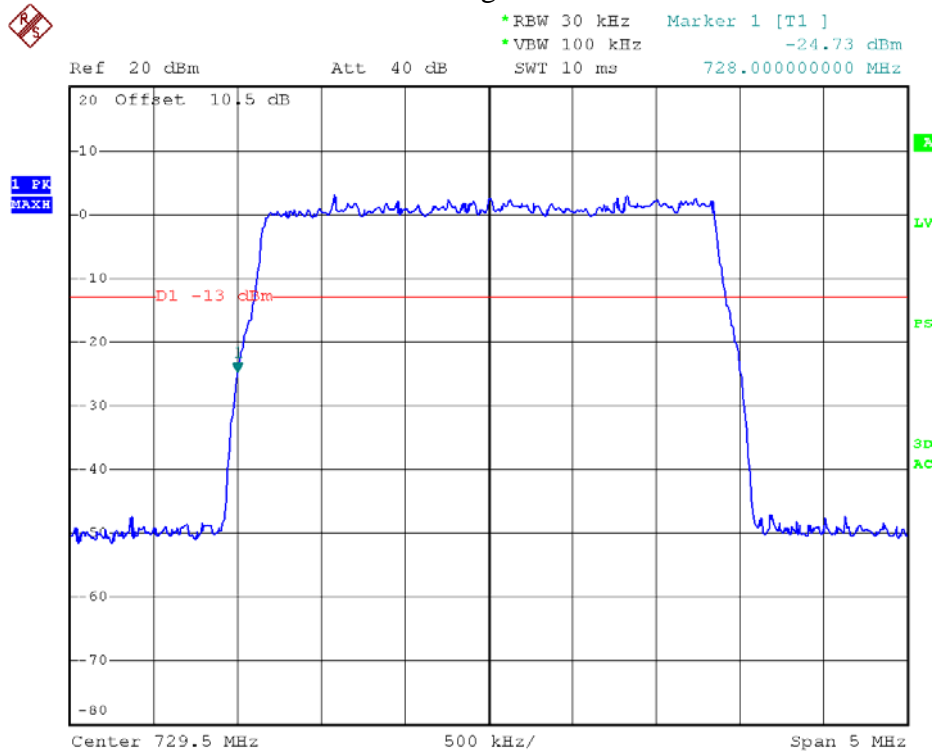

700MHz- LTE-3M Channel Bandwidth -Upper Edge

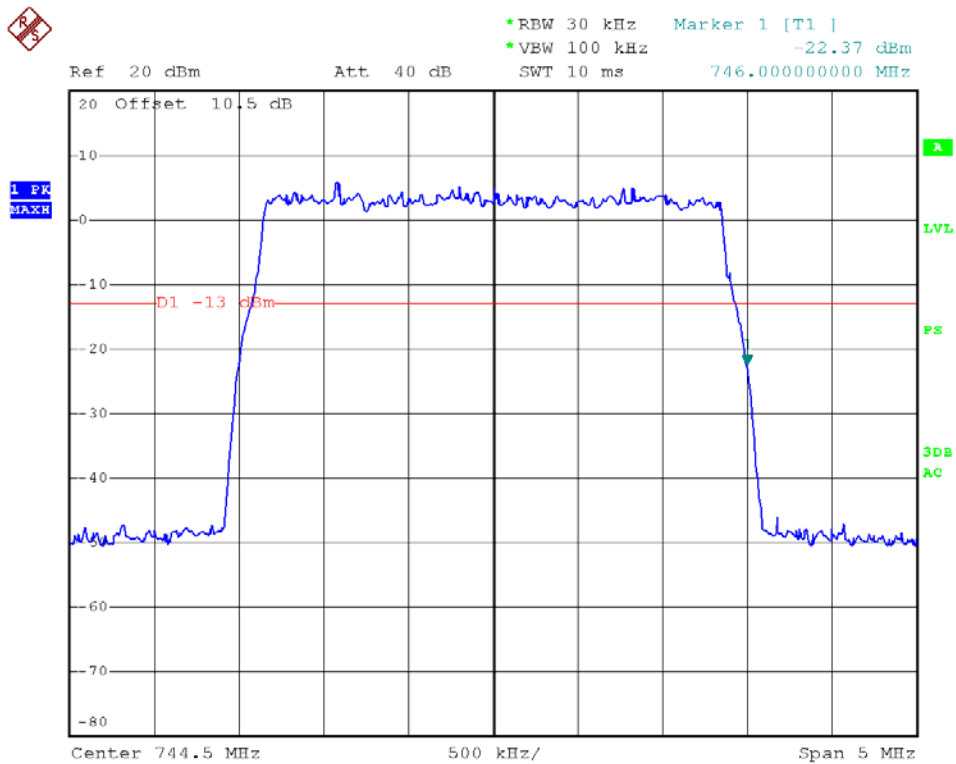

700MHz-LTE-5M Channel Bandwidth -Lower Edge

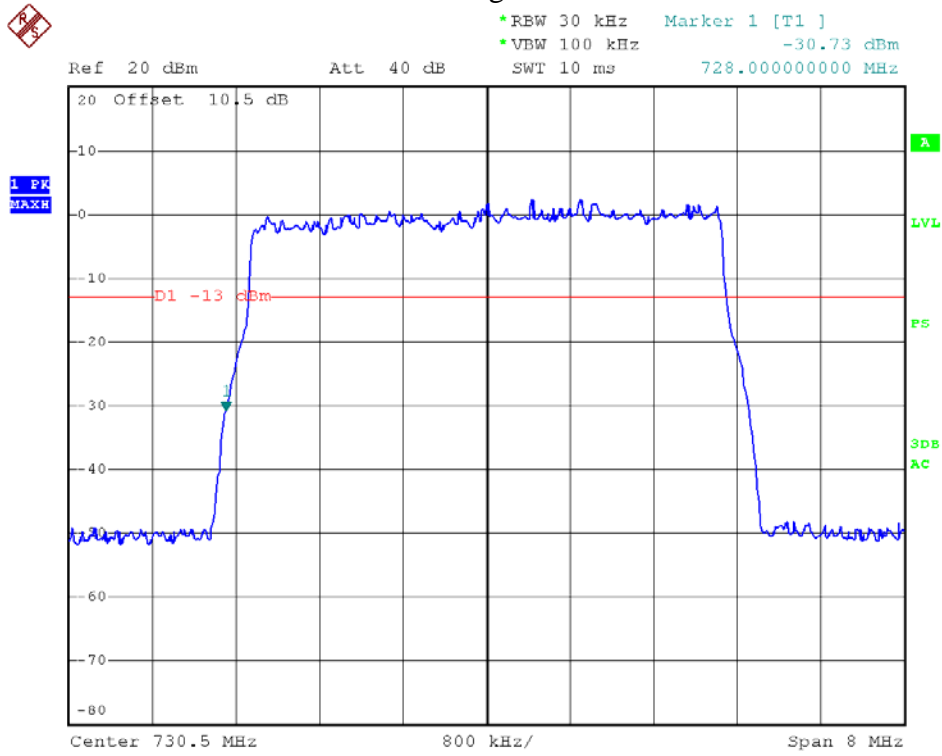

700MHz- LTE-5M Channel Bandwidth -Upper Edge

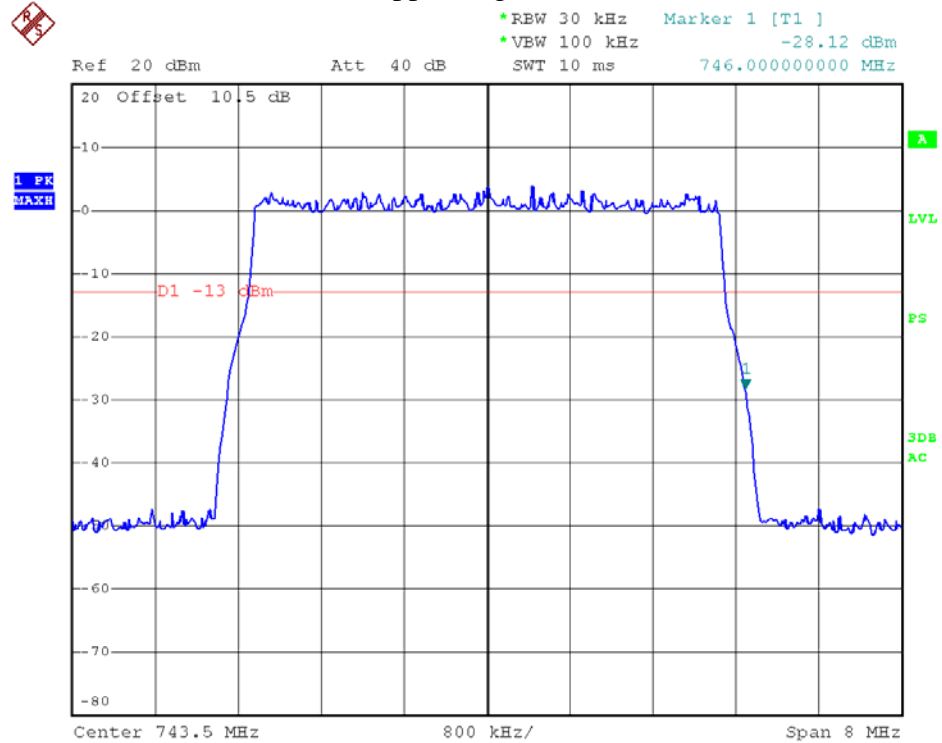

700MHz- LTE-10M Channel Bandwidth -Lower Edge

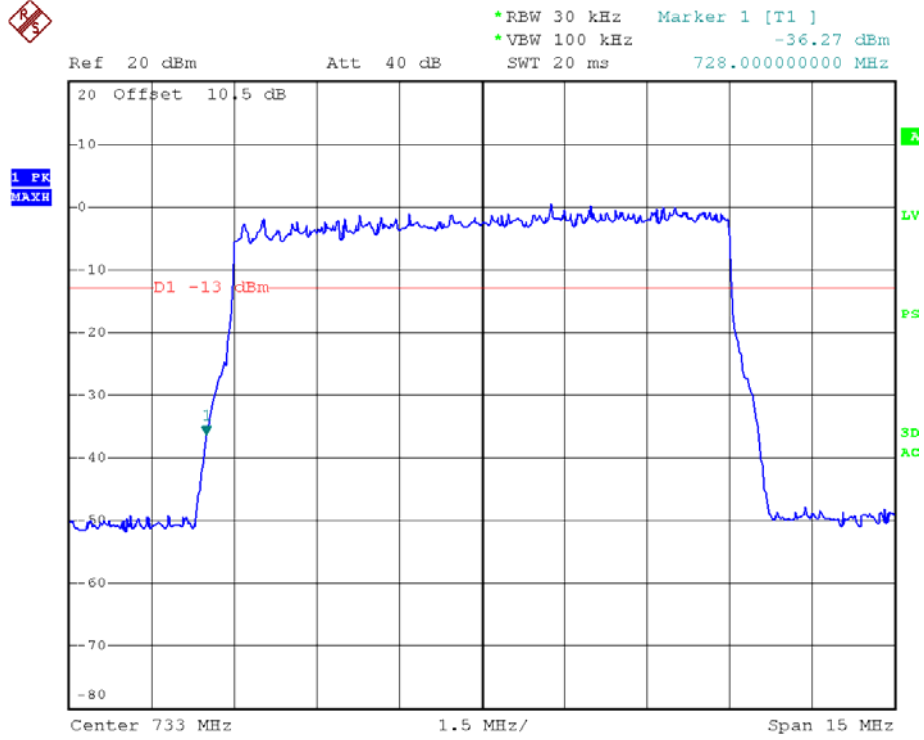

700MHz- LTE-10M Channel Bandwidth -Upper Edge

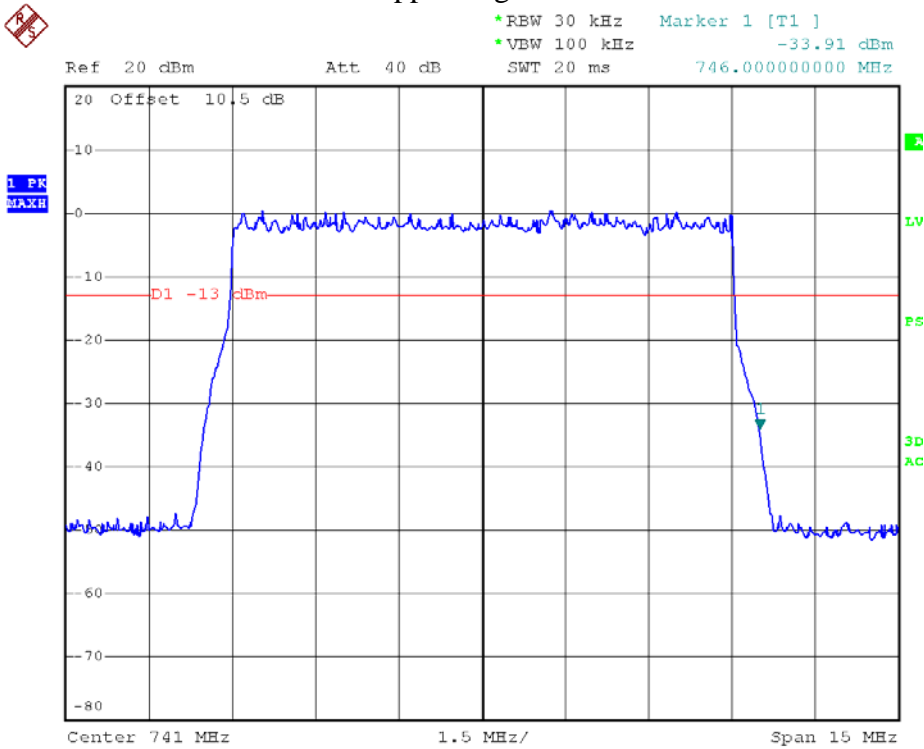

700MHz- LTE-15M Channel Bandwidth -Lower Edge

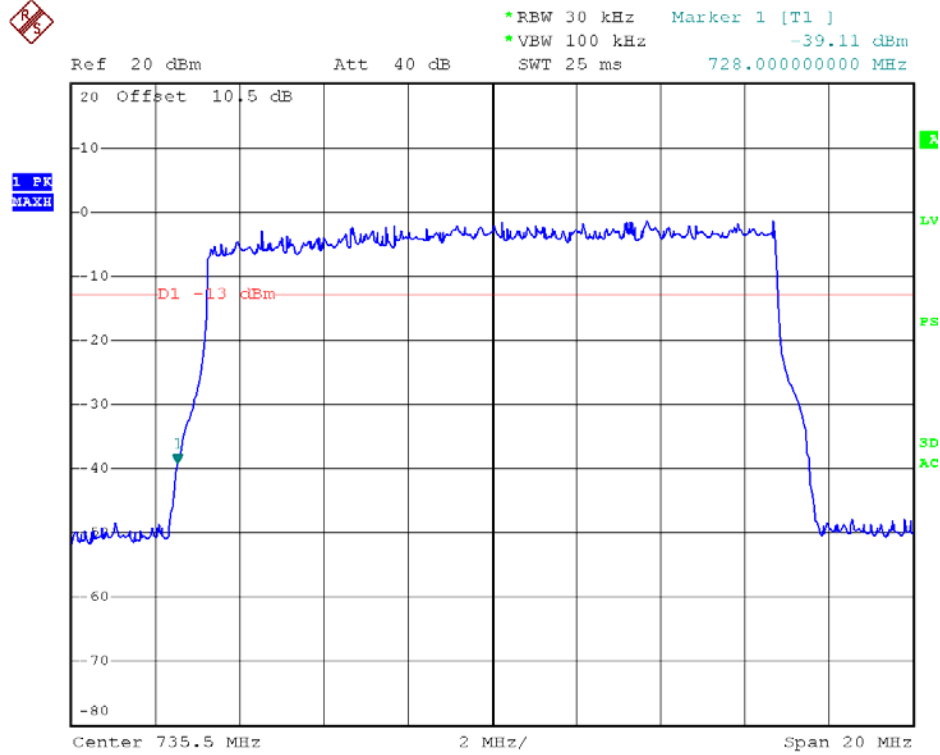

700MHz- LTE-15M Channel Bandwidth -Upper Edge

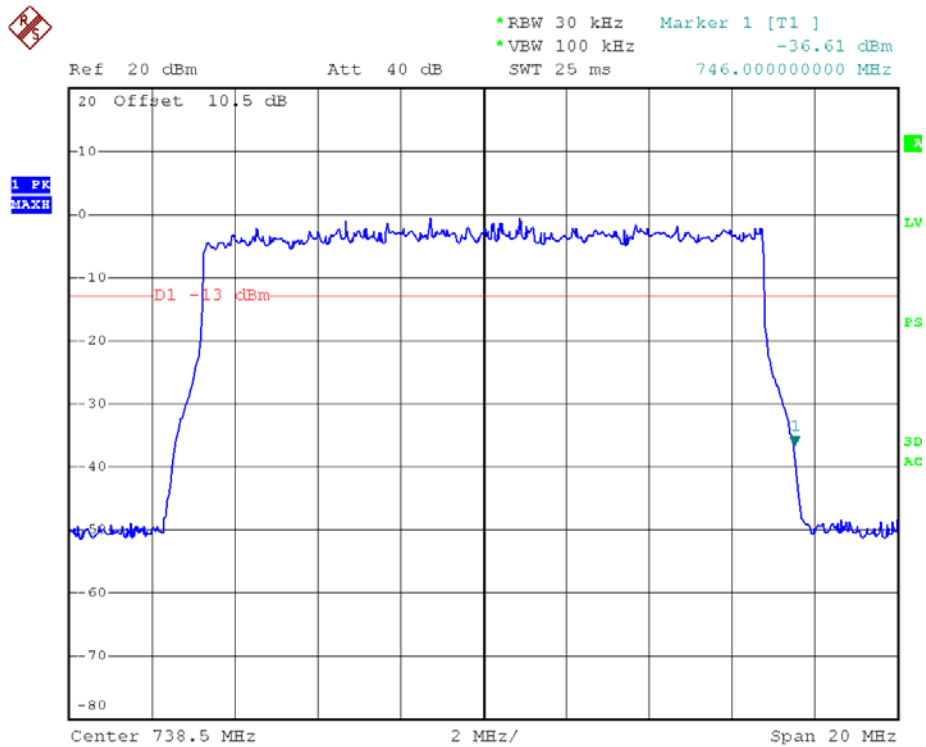

2100MHz- LTE-1.4M Channel Bandwidth -Lower Edge

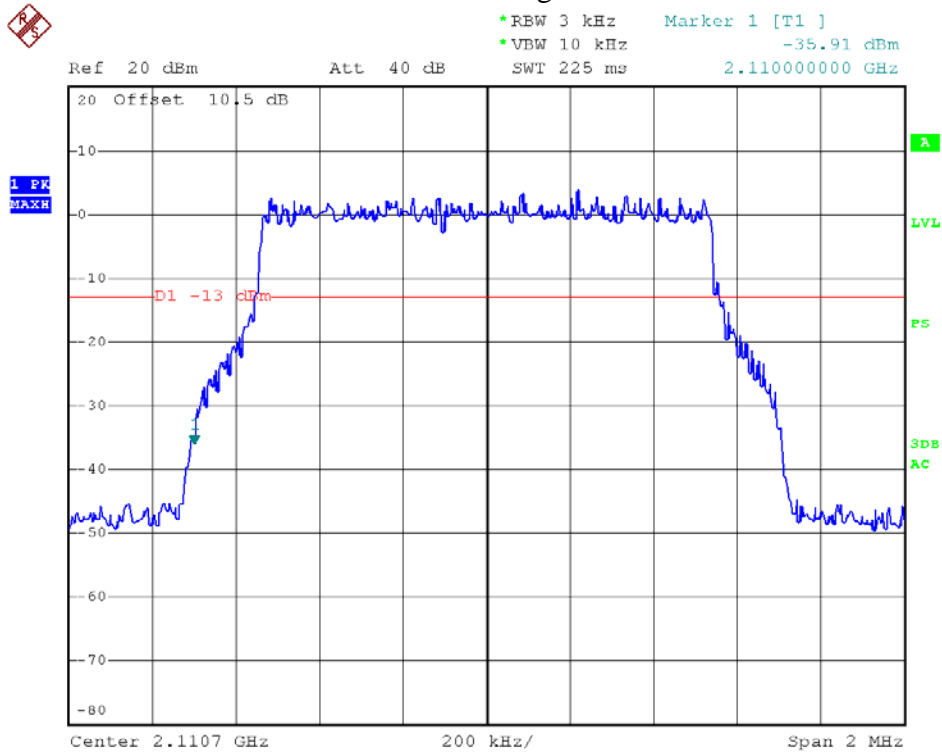

2100MHz- LTE-1.4M Channel Bandwidth -Upper Edge

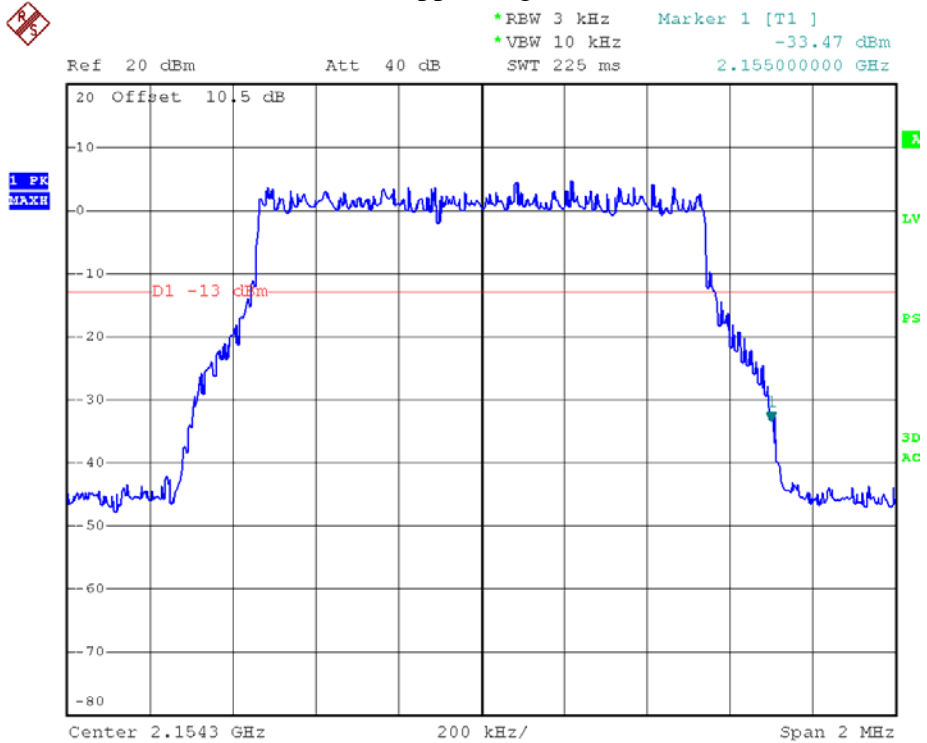

2100MHz- LTE-3M Channel Bandwidth -Lower Edge

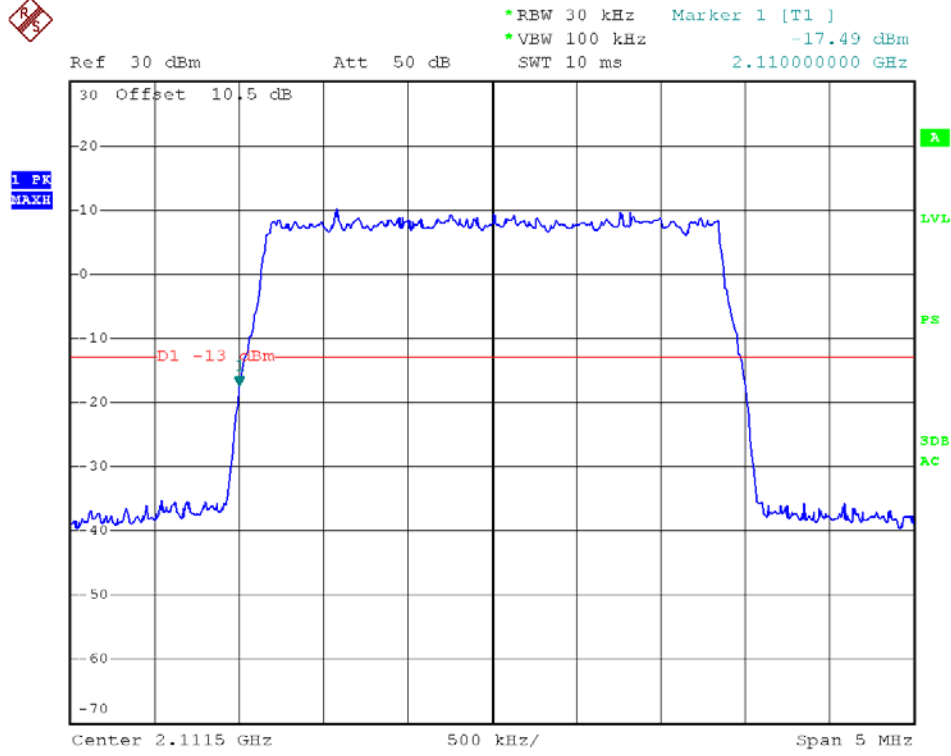

2100MHz- LTE-3M Channel Bandwidth -Upper Edge

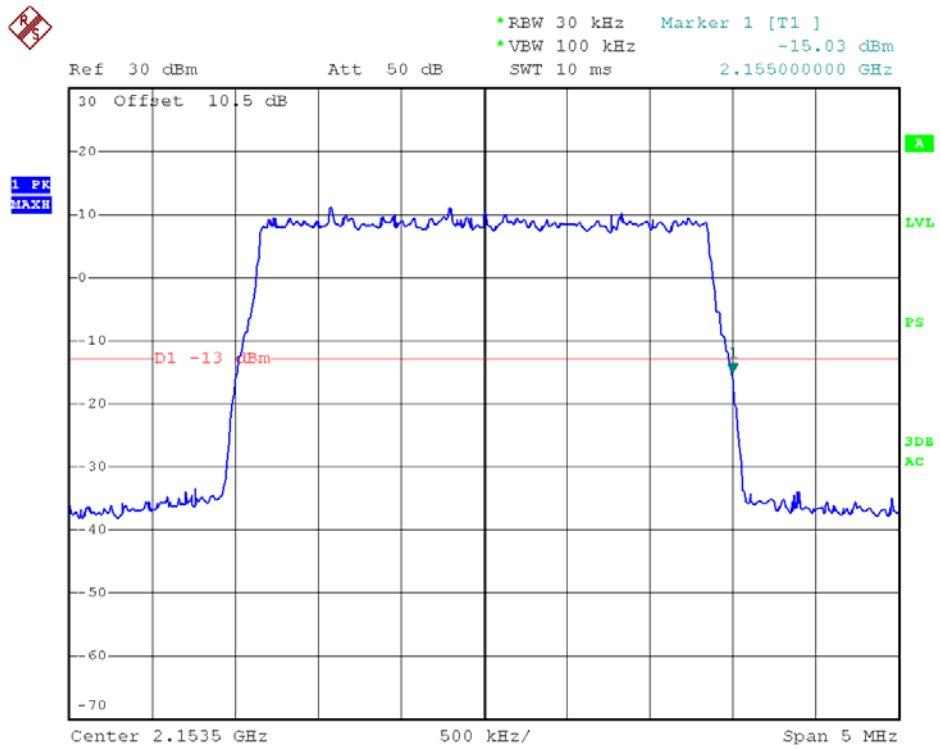

2100MHz- LTE-5M Channel Bandwidth -Lower Edge

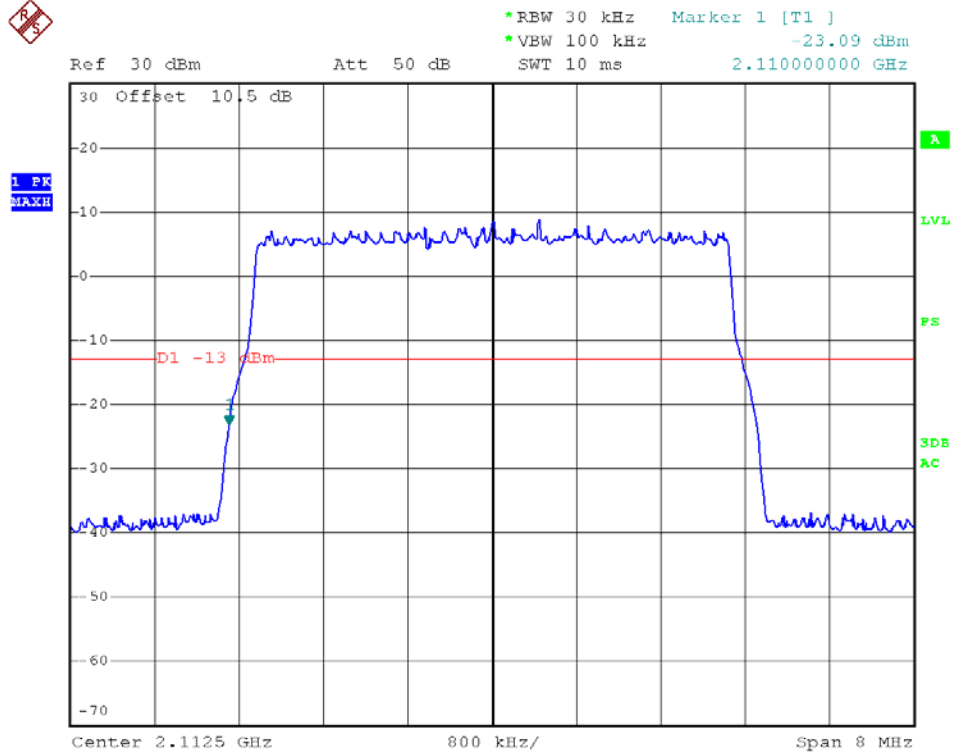

2100MHz- LTE-5M Channel Bandwidth -Upper Edge

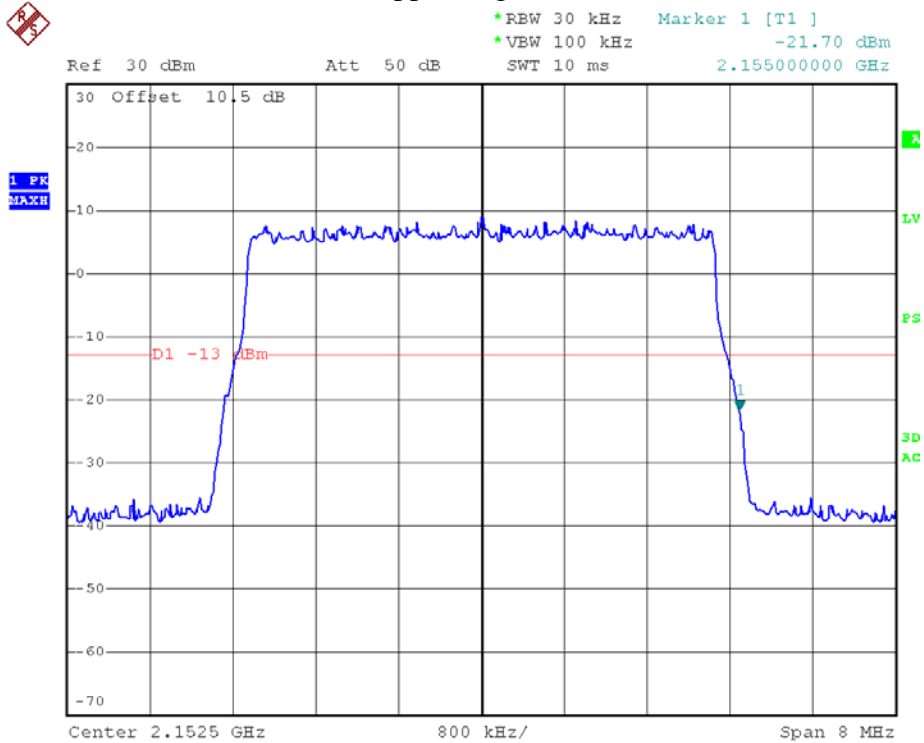

2100MHz- LTE-10M Channel Bandwidth -Lower Edge

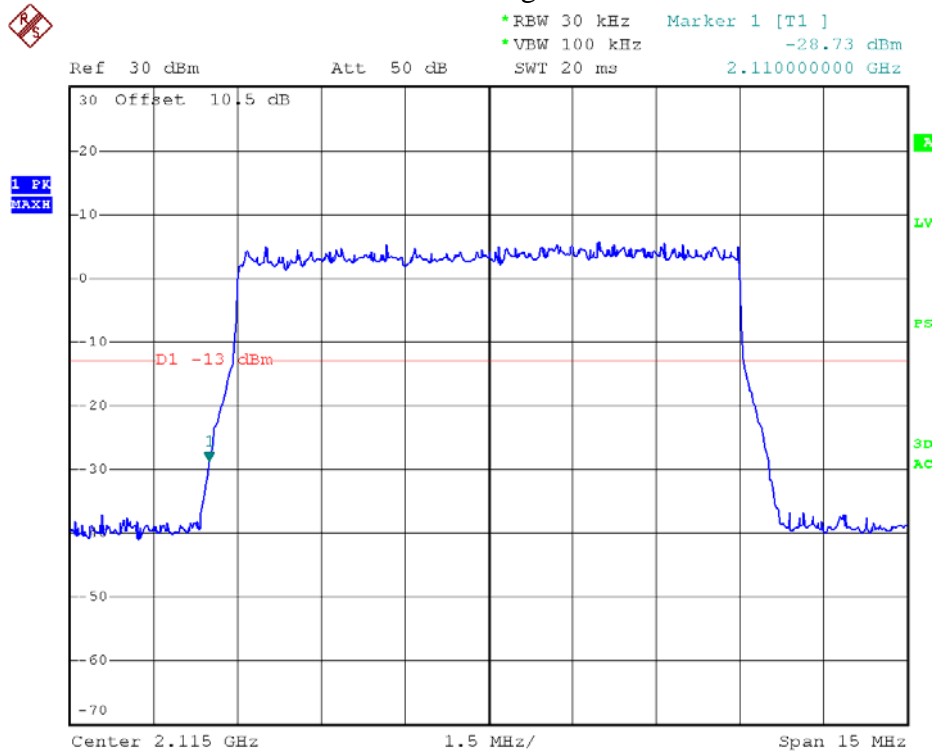

2100MHz- LTE-10M Channel Bandwidth -Upper Edge

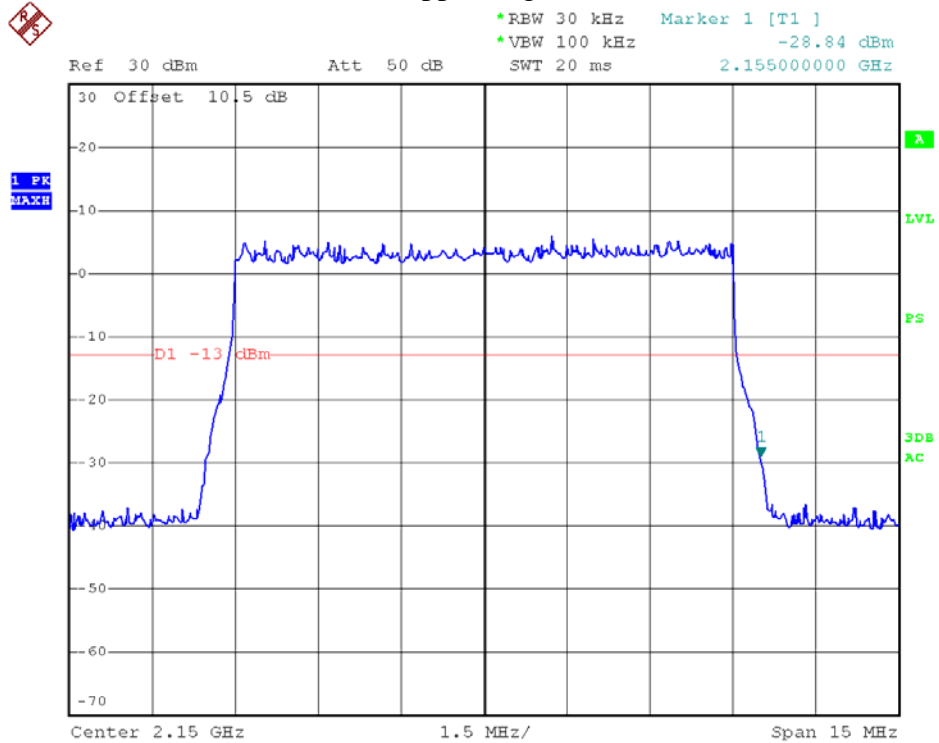

2100MHz- LTE-15M Channel Bandwidth -Lower Edge

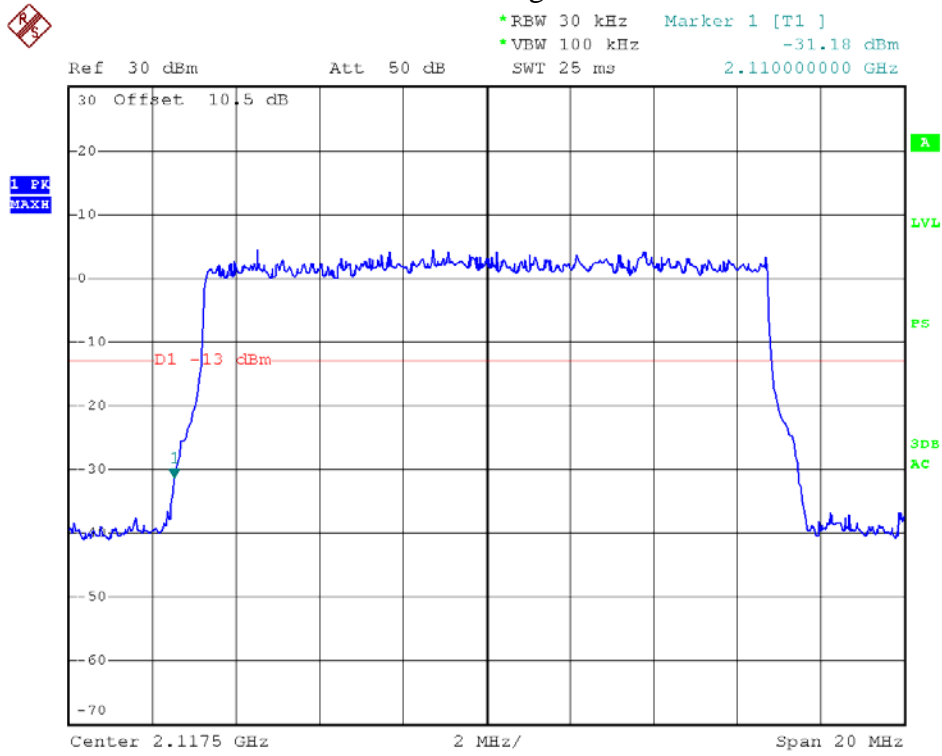

2100MHz- LTE-15M Channel Bandwidth -Upper Edge

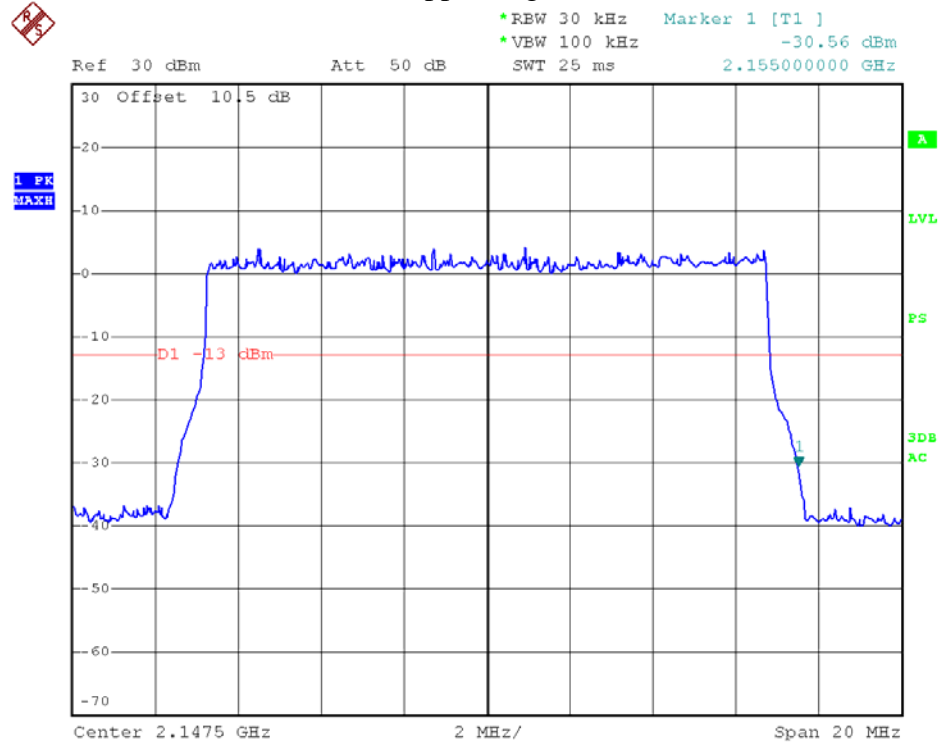

2100MHz-WCDMA-Lower Edge

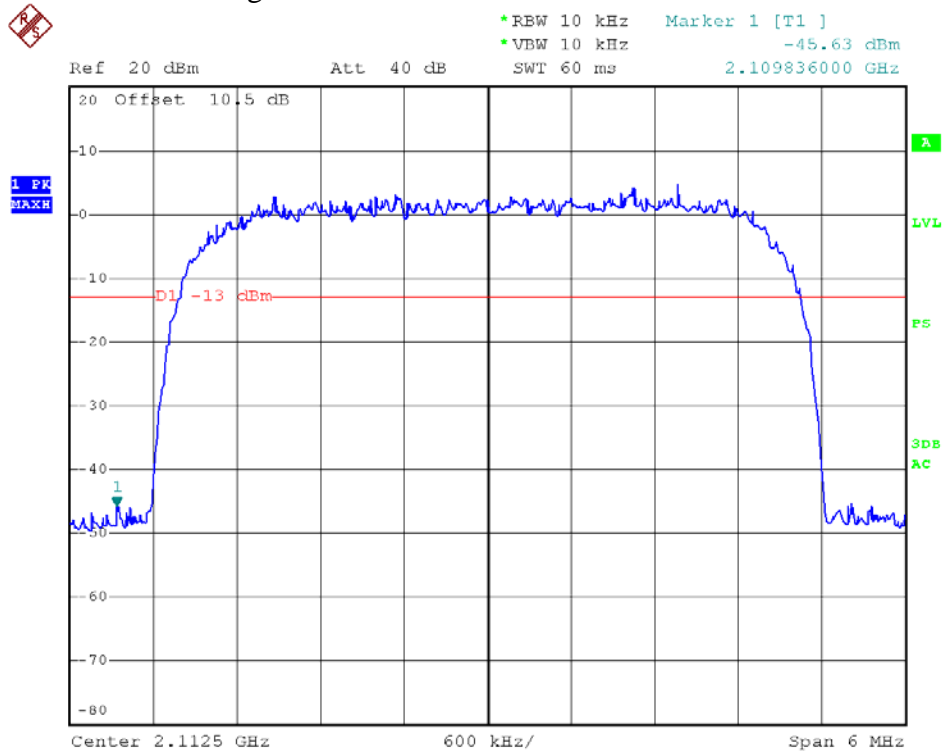

2100MHz-WCDMA-Upper Edge

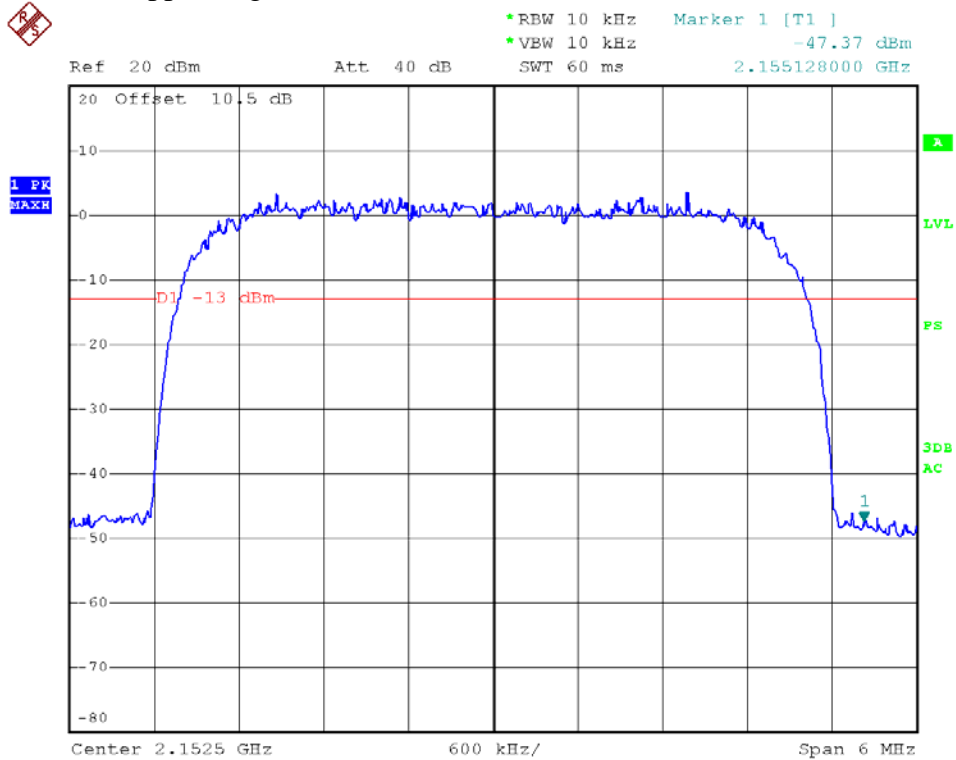

4.2.4 RADIATED SPURIOUS EMISSIONS

Test Date: 11 November, 2012

Test Method: FCC part 2.1053

Test Requirement: FCC 27.53: The power of any emission outside of the authorized operating frequency ranges must be attenuated below the transmitting power (P) by a factor of at least $43 + 10\log(P)$ dB.

Status: The output power of EUT be set to maximum value, the gain of EUT be set to maximum value by software through the manufacture

Condition: Normal conditions

Application: Enclosure

Test Configuration:

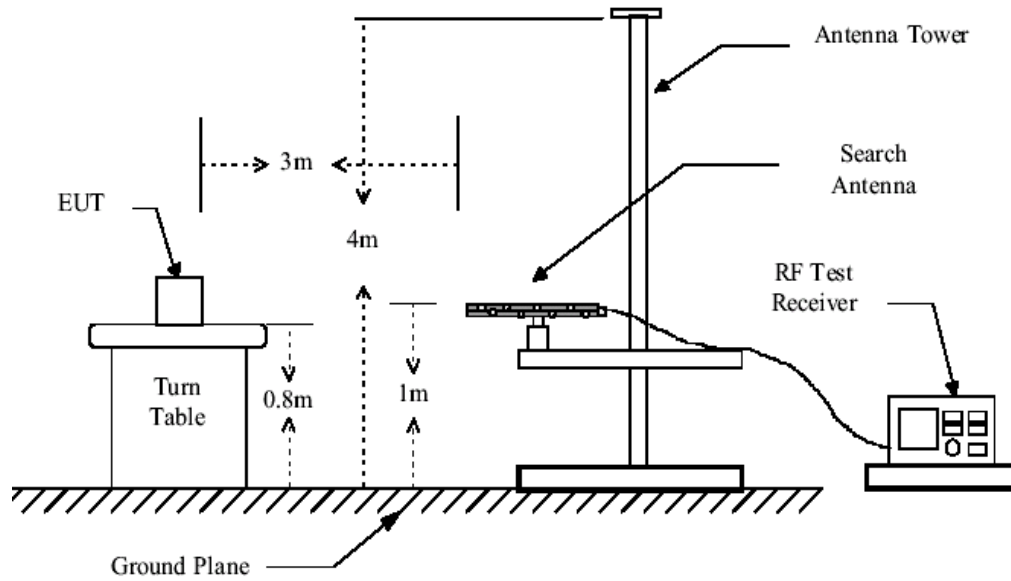

Figure 1. 30 MHz to 1GHz radiated emissions test configuration

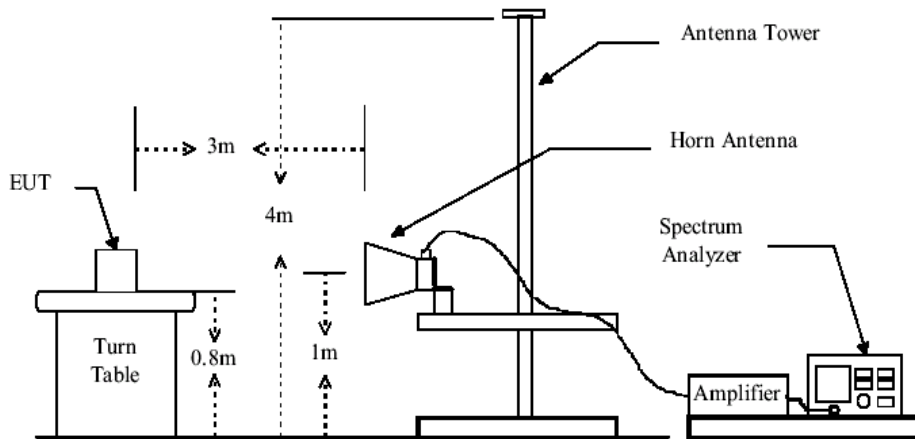
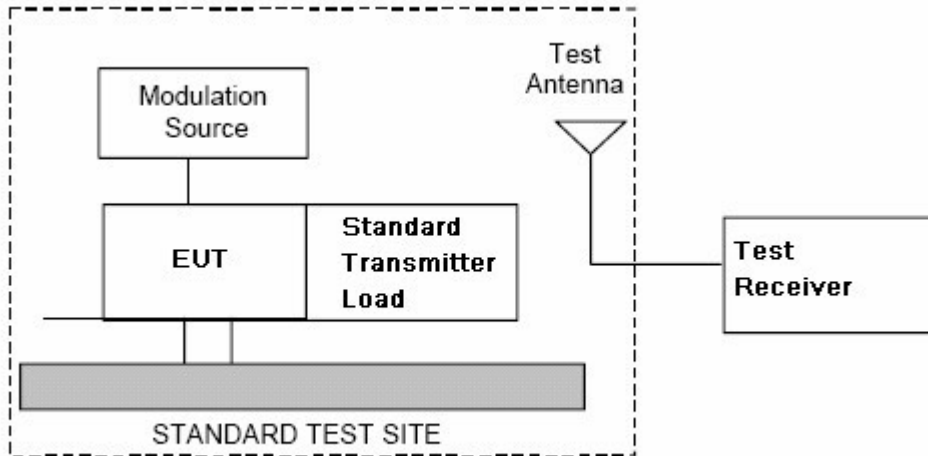

Figure 2. Above 1GHz radiated emissions test configuration

- Test Procedure:**
1. Test the background noise level with all the facilities
 2. Keep one transmitting path, all other connectors shall be connected by normal power or RF leads,
 3. Select the suitable RF notch filter to avoid the test receiver or spectrum analyzer produce unwanted spurious emissions,
 4. Keep the EUT continuously transmitting in max power.
 5. Read the radiated emissions of the EUT enclosure.

Radiated Emission Test Procedure:



- a) Connect the equipment as illustrated
- b) Adjust the spectrum analyzer for the following setting;
 - 1) RBW=100KHZ for spurious emission below 1GHZ ,and 1MHz for spurious emission above 1GHZ
 - 2) VBW=300KHZ for spurious emission below 1GHZ ,and 3MHz for spurious emission above 1GHZ
 - 3) Sweep speed slow enough to maintain measurement calibration
 - 4) Detector Mode=Positive Peak
- c) Place the transmitter to be tested on the turntable in the standard test site, The transmitter is transmitting into a nonradiating load that is placed on the turntable ,the RF cable to this load should be of minimum length.
- d) Measurements shall be made from 30MHz to 10 times of fundamental carrier, except for the region close to the carrier equal to \pm the carrier bandwidth.
- e) Key the transmitter without modulation or normal modulation base the standard.
- f) For each spurious frequency, raise and lower the test antenna from 1 m to 4 m to obtain a maximum reading on the spectrum analyzer with the test antenna at horizontal polarity. Then the turntable should be rotated 360 to determine the maximum reading. Repeat this procedure to obtain the highest possible reading. Record this maximum reading.
- g) Repeat step f) for each spurious frequency with the test antenna polarized vertically.

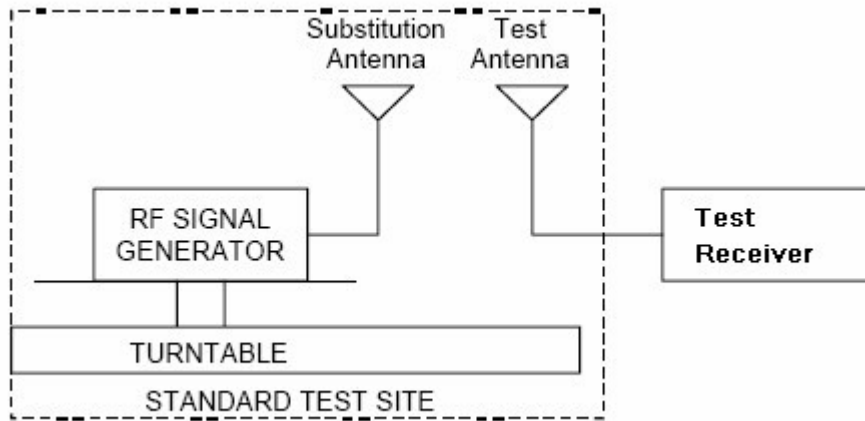

- h) Reconnect the equipment as illustrated.
- i) Keep the spectrum analyzer adjusted as in step b)
- j) Remove the transmitter and replace it with a substitution antenna (the antenna should be half wavelength for each frequency involved). The center of the substitution antenna should be approximately at the same location as the center of the transmitter. At the lower frequencies, where the substitution antenna is very long, this will be impossible to achieve when the antenna is polarized vertically. In such case the lower end of the antenna should be 0.3m above the ground.
- k) Feed the substitution antenna at the transmitter end with a signal generator connected to the antenna by means of a nonradiating cable. With the antennas at both ends horizontally polarized, and with the signal generator tuned to a particular spurious frequency, raise and lower the test antenna to obtain a maximum reading at the spectrum analyzer. Adjust the level of the signal generator output until the previously recorded maximum reading or this set of conditions is obtained. This should be done carefully repeating the adjustment of the test antenna and generator output.
- l) Repeat step k) with both antennas vertically polarized for each spurious frequency.
- m) Calculate power in dBm into a reference ideal half-wave dipole antenna by reducing the readings obtained in step k) and i) by the power loss in the cable between the generator and the antenna, and further corrected for the gain of the substitution antenna used relative to an ideal half-wave dipole antenna by the following formula:

$$P_d(\text{dBm}) = P_g(\text{dBm}) - \text{cable loss (dB)} + \text{antenna gain (dB)}$$

where:

P_d is the dipole equivalent power and

P_g is the generator output power into the substitution antenna.

NOTE: It is permissible to use other antennas provided they can be referenced to a dipole.

NOTE: Effective radiated power (e.r.p) refers to the radiation of a half wave tuned dipole instead of an isotropic antenna. There is a constant difference of 2.15 dB between e.i.r.p. and e.r.p.e.r.p (dBm)-2.15

4.2.4.1 MEASUREMENT RECORD

Test Frequency (MHz)	Measuring level(dBm)		Limits (dBm)	Margin(dB)	
	Vertical	Horizontal		Vertical	Horizontal
30	N/A	N/A	-13	N/A	N/A
500	N/A	N/A	-13	N/A	N/A
1000	N/A	N/A	-13	N/A	N/A
2000	N/A	N/A	-13	N/A	N/A
5000	N/A	N/A	-13	N/A	N/A
10000	N/A	N/A	-13	N/A	N/A
15000	N/A	N/A	-13	N/A	N/A
20000	N/A	N/A	-13	N/A	N/A

Remark:

N/A,not applicable or the level i too weak to bo etected.

Swcap all the moulation tyoes emissions in Cellular band and PCS band,find the worse case to report it.

4.2.5 OCCUPIED BANDWIDTH

Test Date: 12 November, 2012

Test Method: FCC part 2.1049&2-11-04/EAB/RF

Test Requirement: 2-11-04/EAB/RF

Status The output power of EUT be set to maximum value, the gain of EUT be set to maximum value by software through the manufacture

Conditions Normal

Test configuration

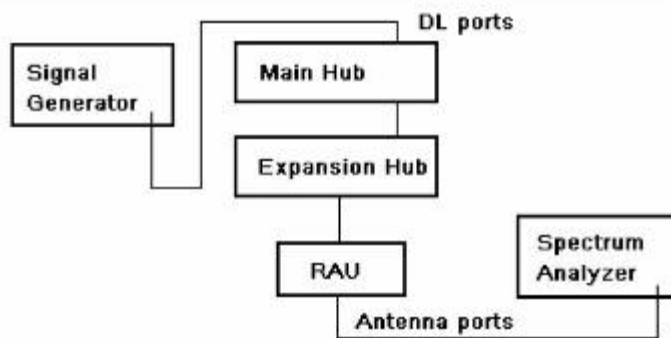

Fig.1 Down Link Configuration

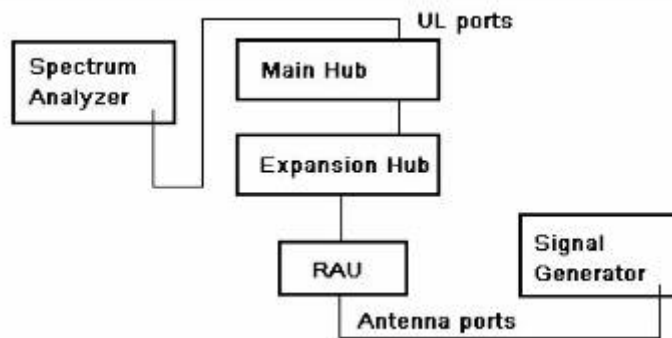

Fig.2 Up Link Configuration

Test Procedure:

- a) Set the spectrum analyzer RBW 300Hz >1%bandwidth of carrier.
- b) Capture the trace of input signal
- c) Connect the equipment as illustrated
- d) Capture the trace of output signal

4.2.5.1 MEASUREMENT RECORD

700MHz-LTE-1.4M downlink (lowest frequency)-Input

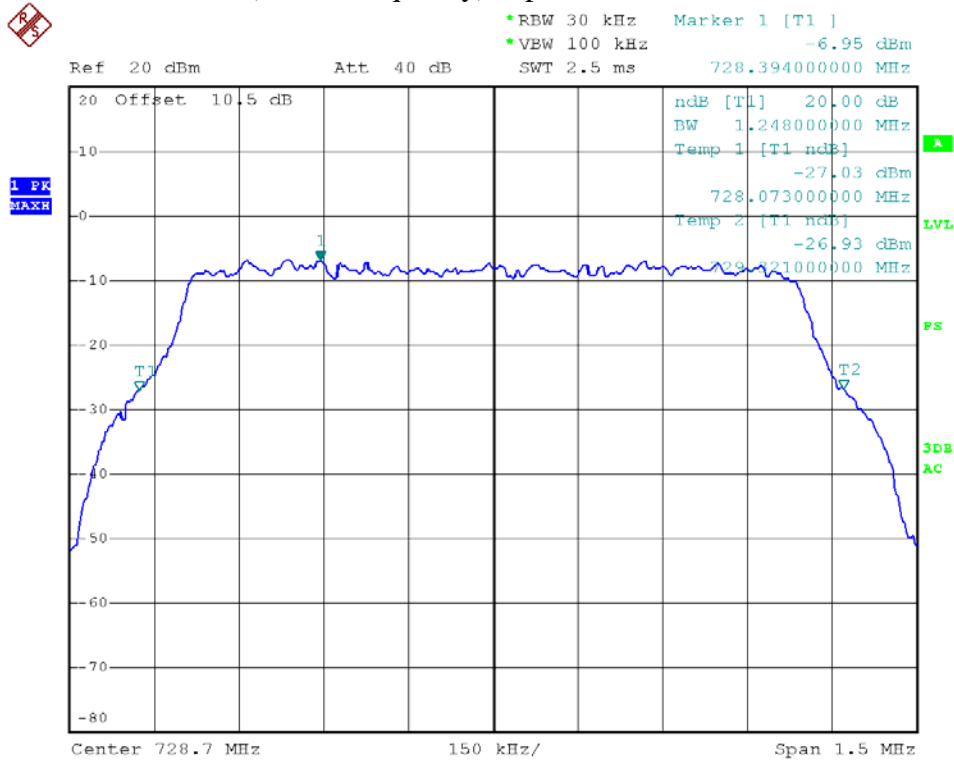

700MHz-LTE-1.4M downlink (lowest frequency)-Output

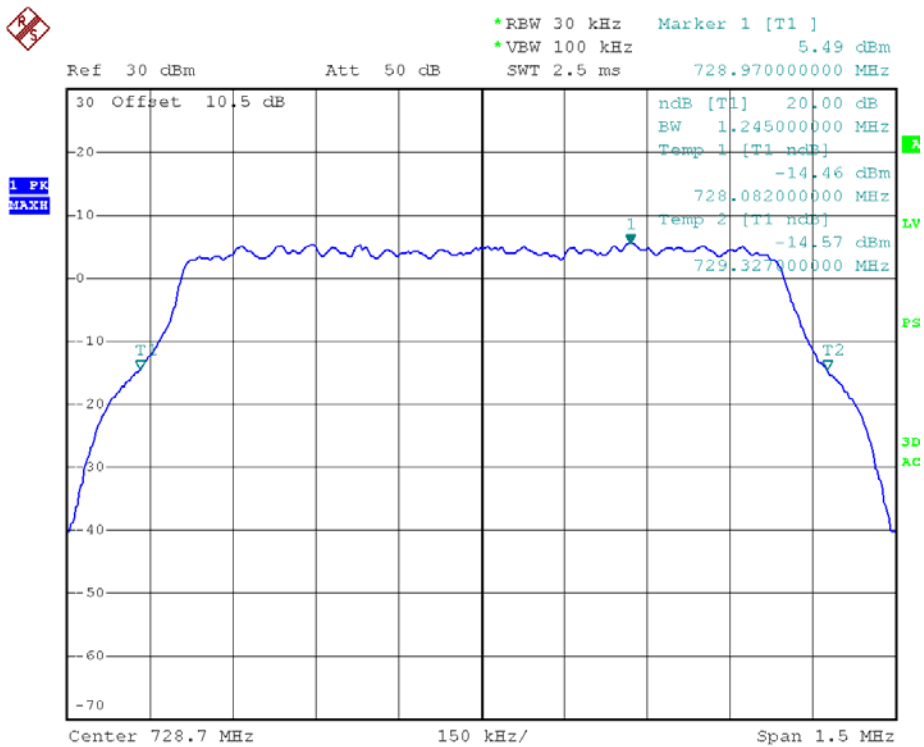

700MHz-LTE-1.4M downlink (middle frequency)-Input

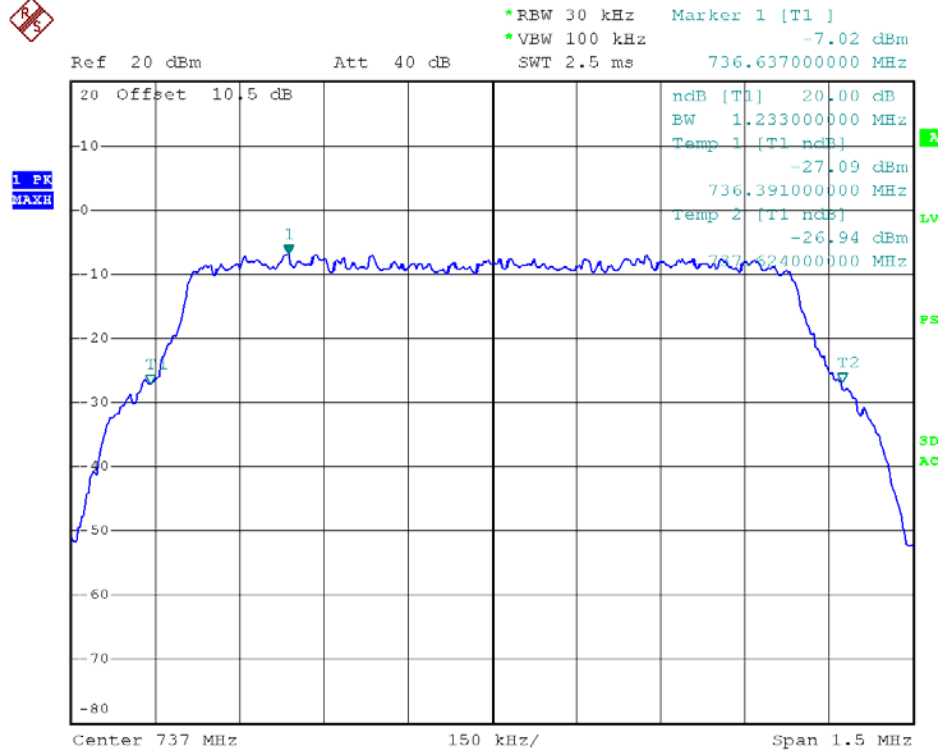

700MHz-LTE-1.4M downlink (middle frequency)- Output

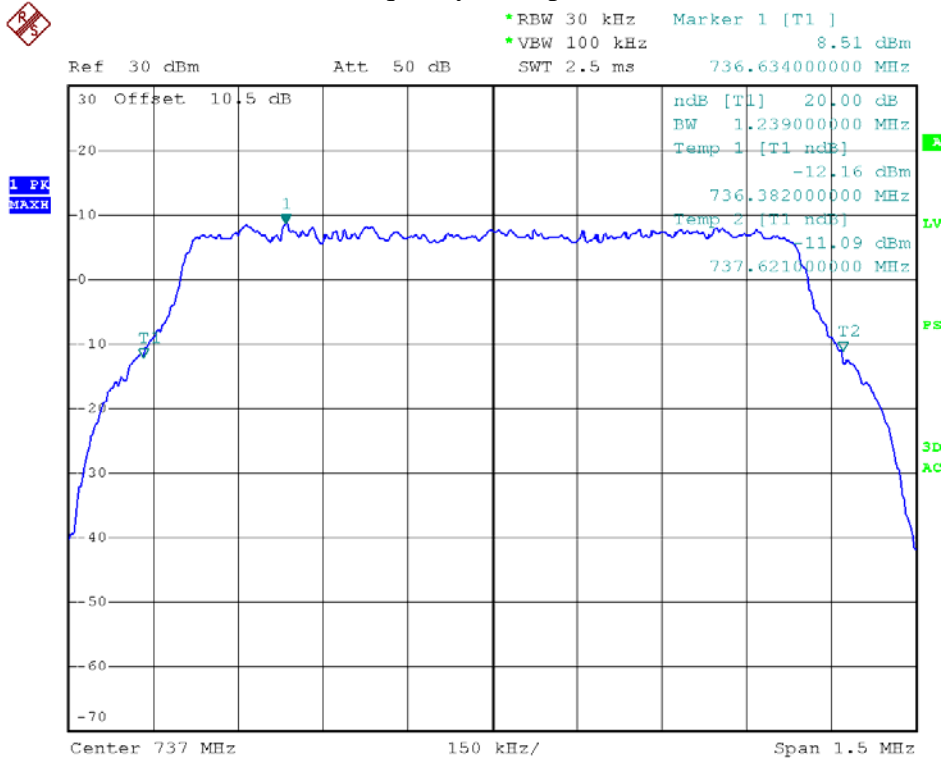

700MHz-LTE -1.4M downlink (highest frequency)-Input

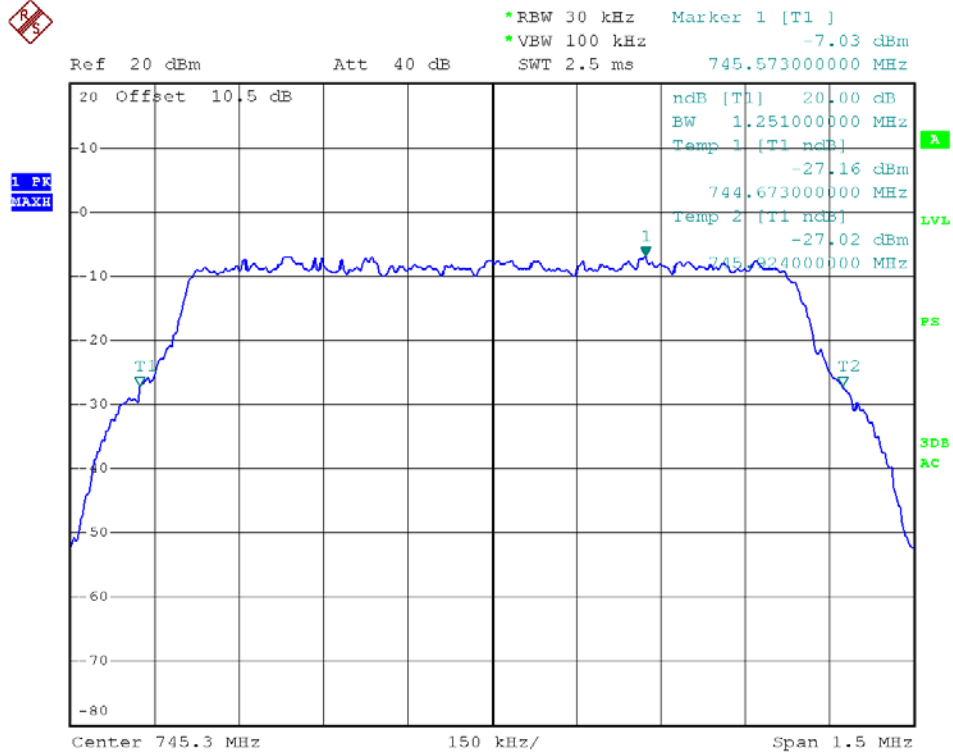

700MHz-LTE-1.4 downlink (highest frequency)- Output

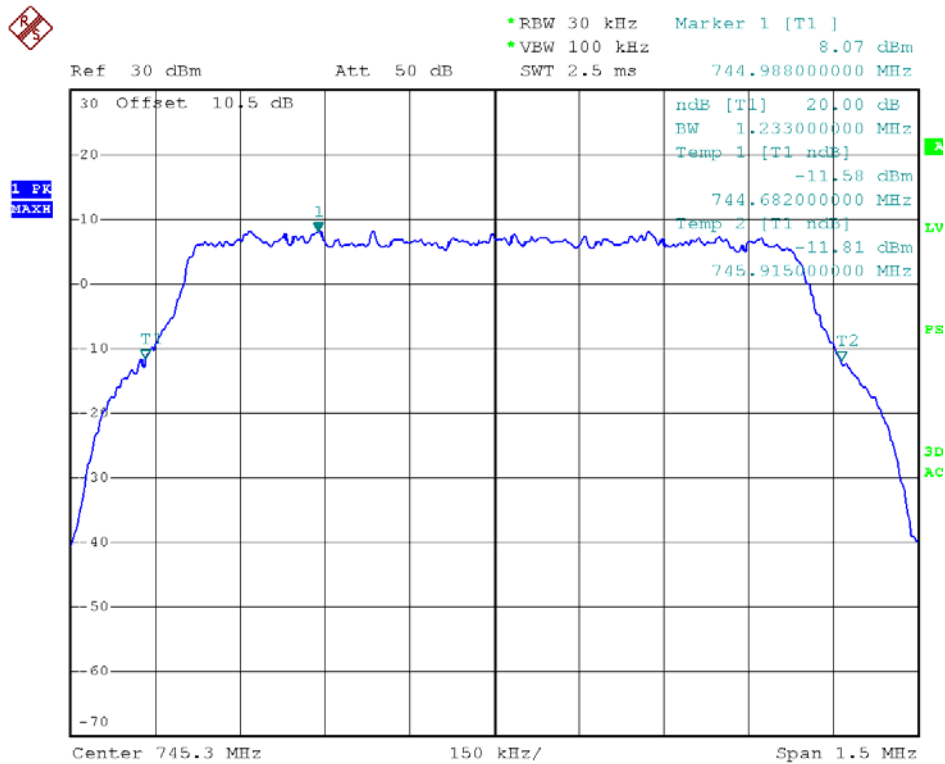

700MHz-LTE-1.4Muplink (lowest frequency)-Input

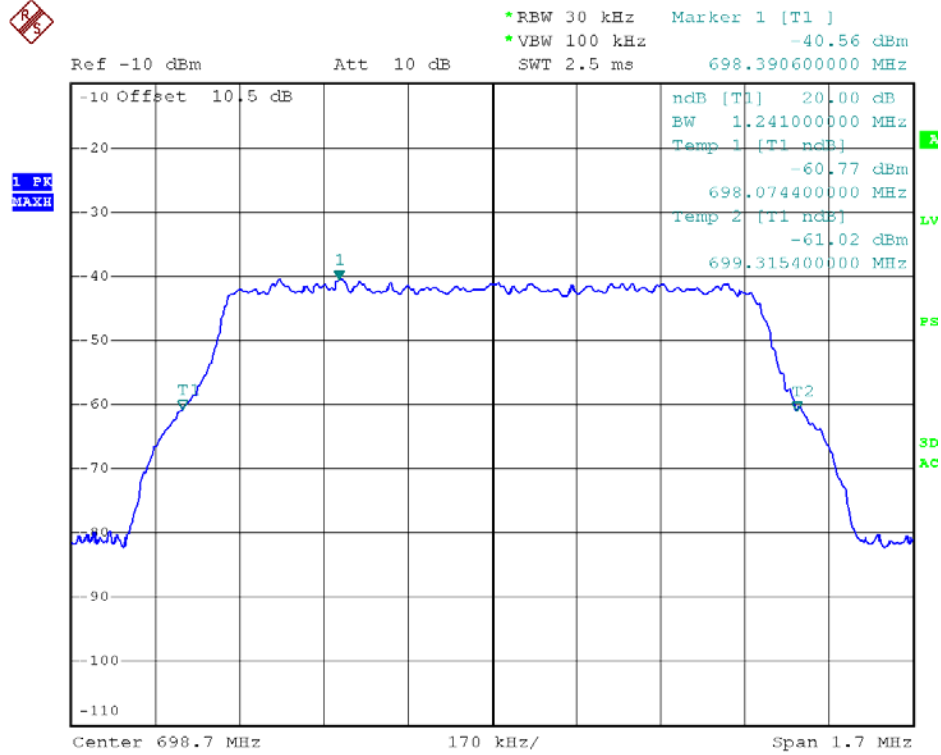

700MHz-LTE-1.4M uplink (lowest frequency)-Output

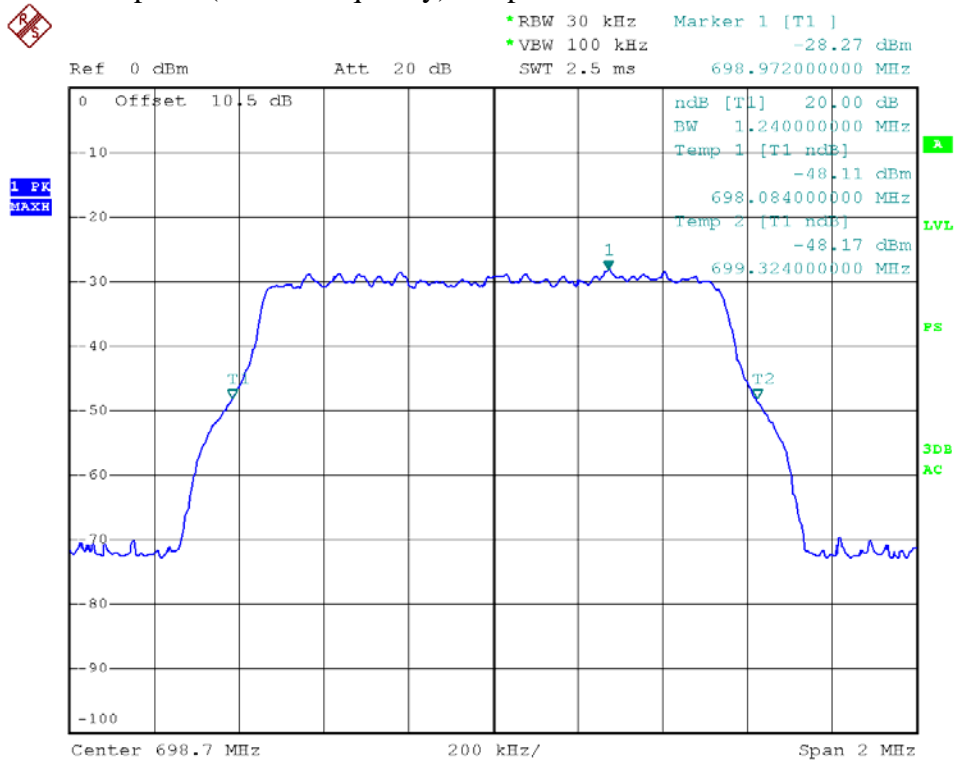

700MHz-LTE-1.4M uplink (middle frequency)- Input

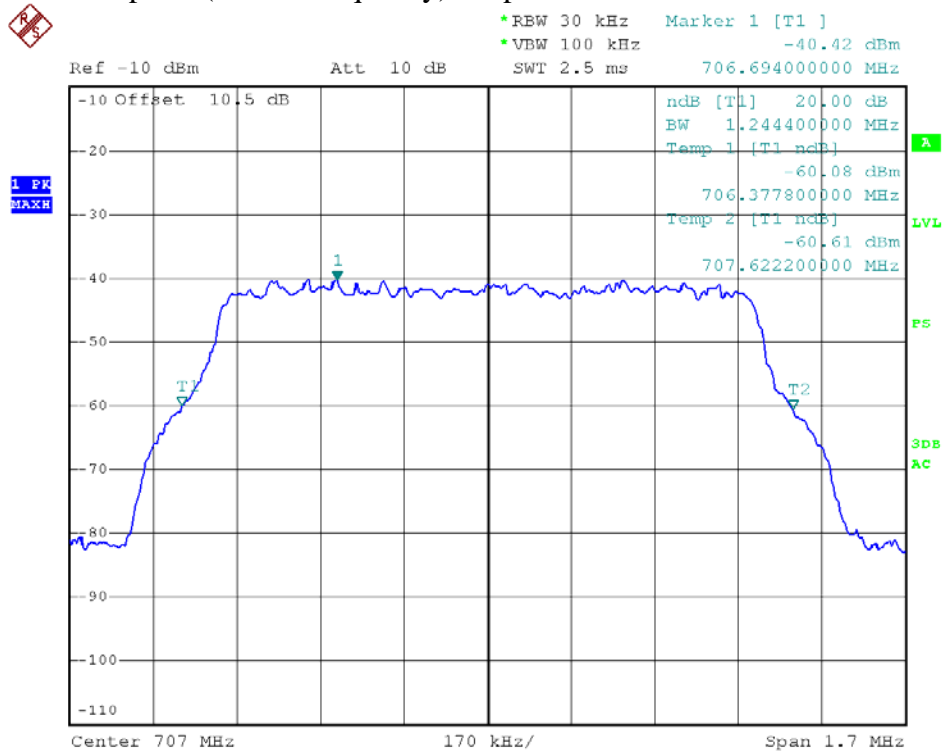

700MHz-LTE -1.4M uplink (middle frequency) -Output

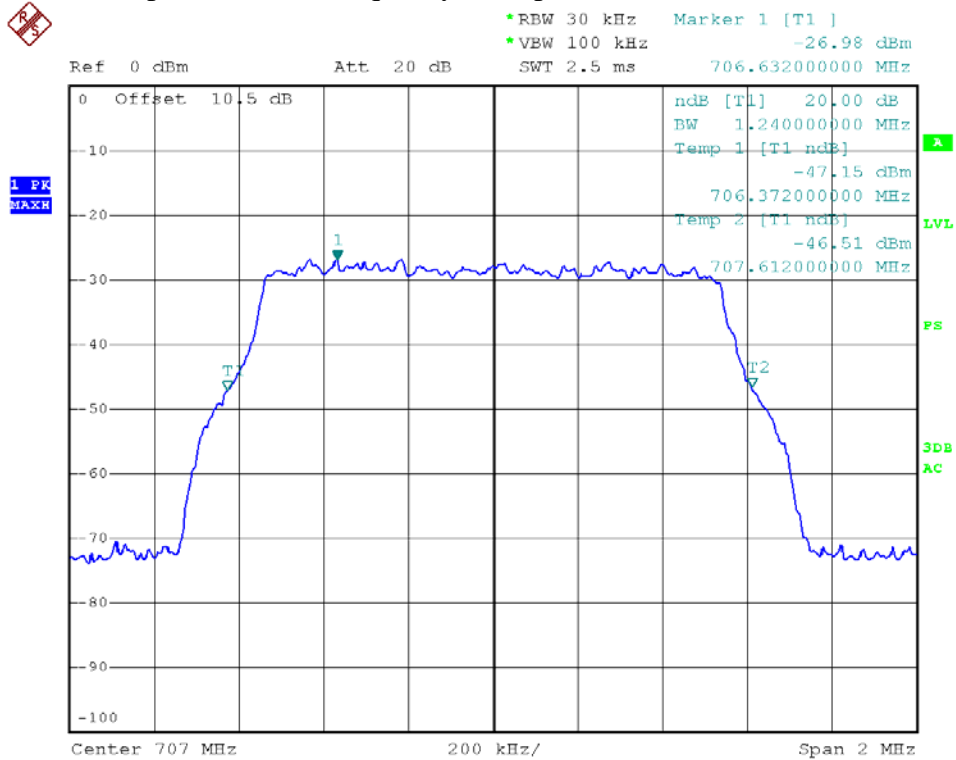

700MHz-LTE -1.4M uplink (highest frequency)-Input

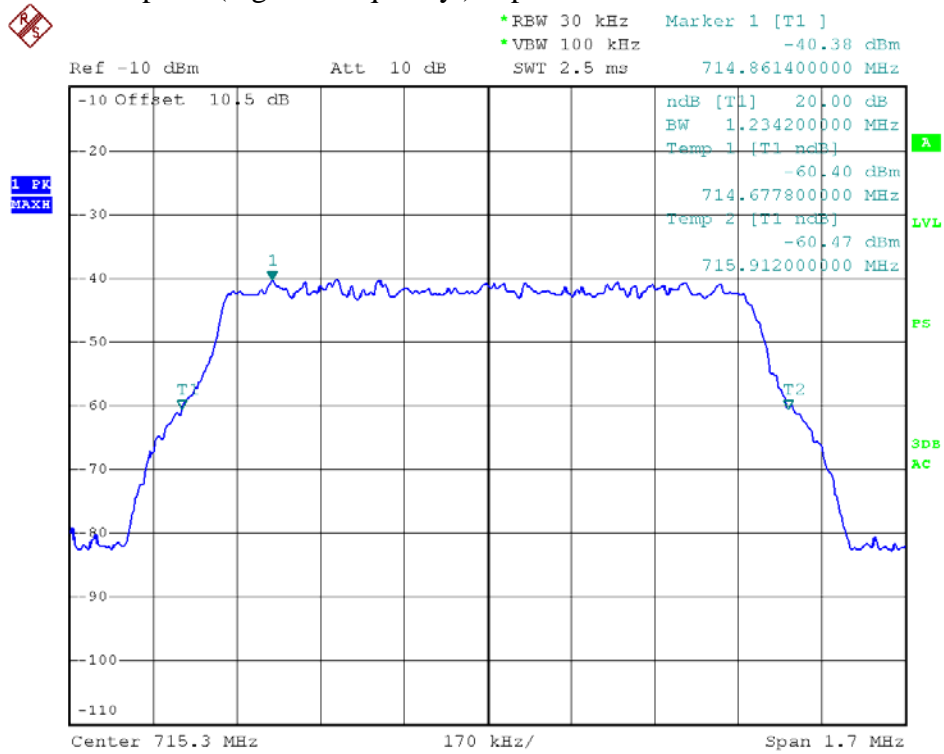

700MHz-LTE-1.4M uplink (highest frequency)- Output

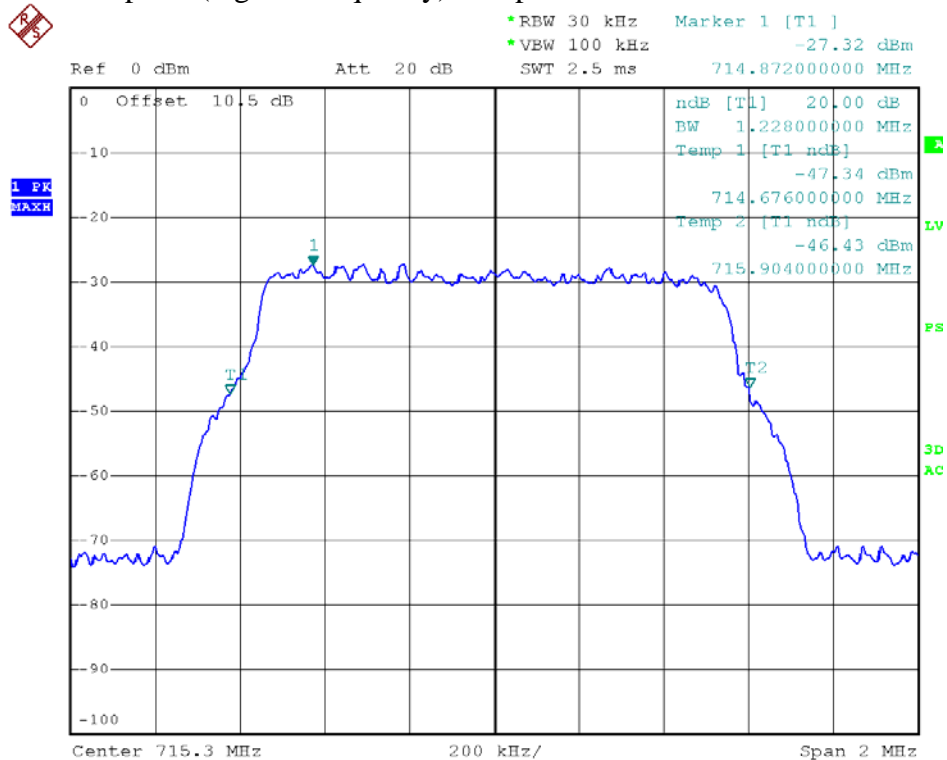

700MHz-LTE-3M downlink (lowest frequency)-Input

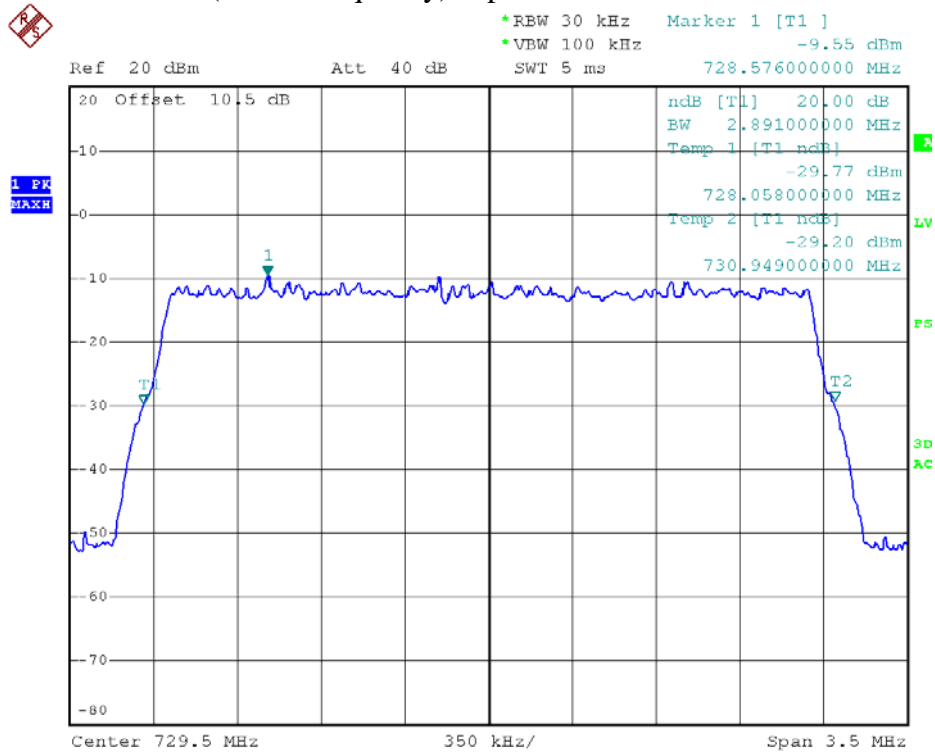

700MHz-LTE-3M downlink (lowest frequency)- Output

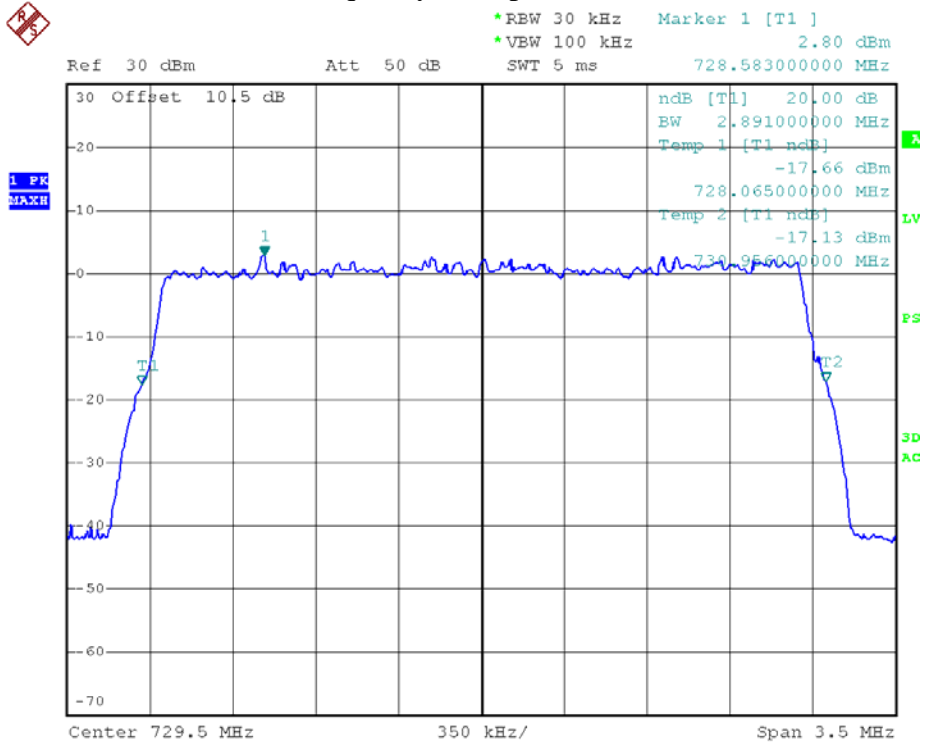

700MHz-LTE-3M downlink (middle frequency)-Input

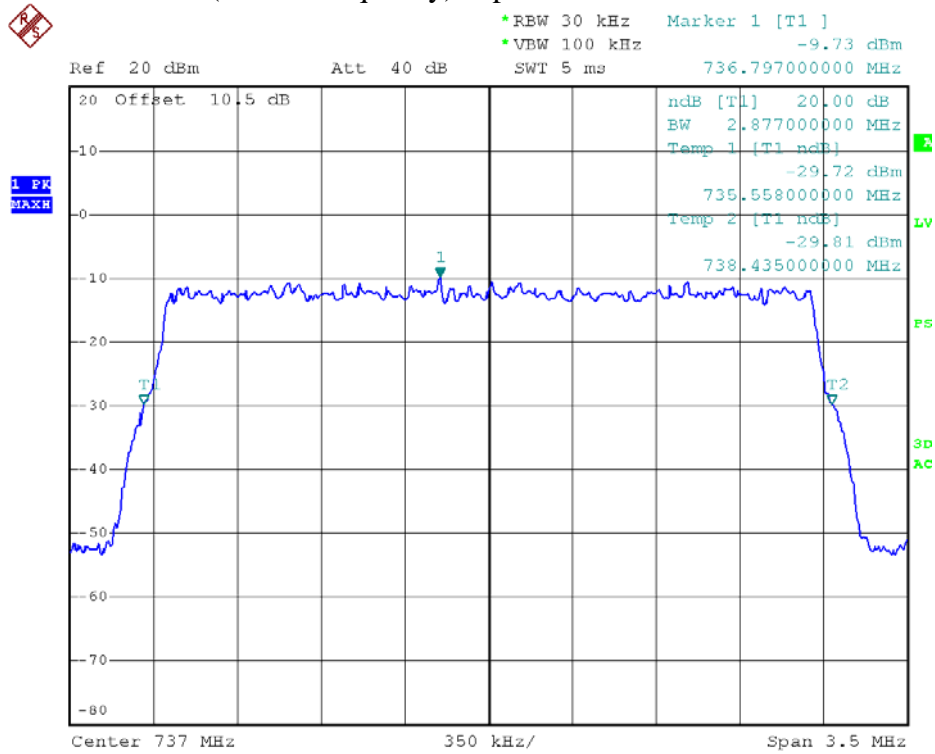

700MHz-LTE-3M downlink (middle frequency)- Output

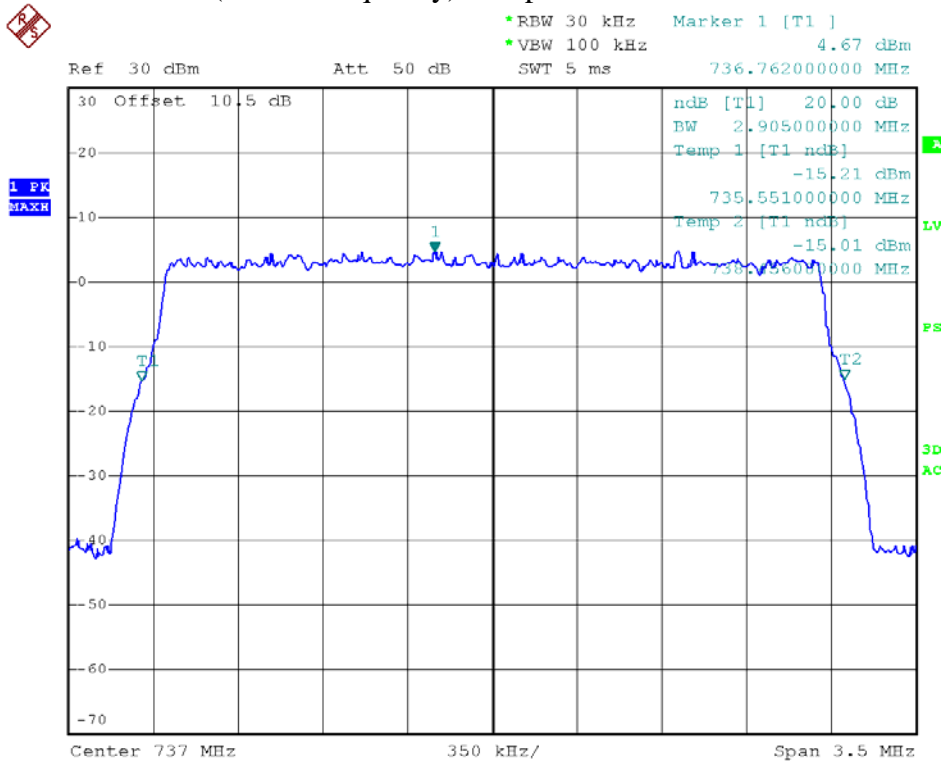

700MHz-LTE-3M downlink (highest frequency)-Input

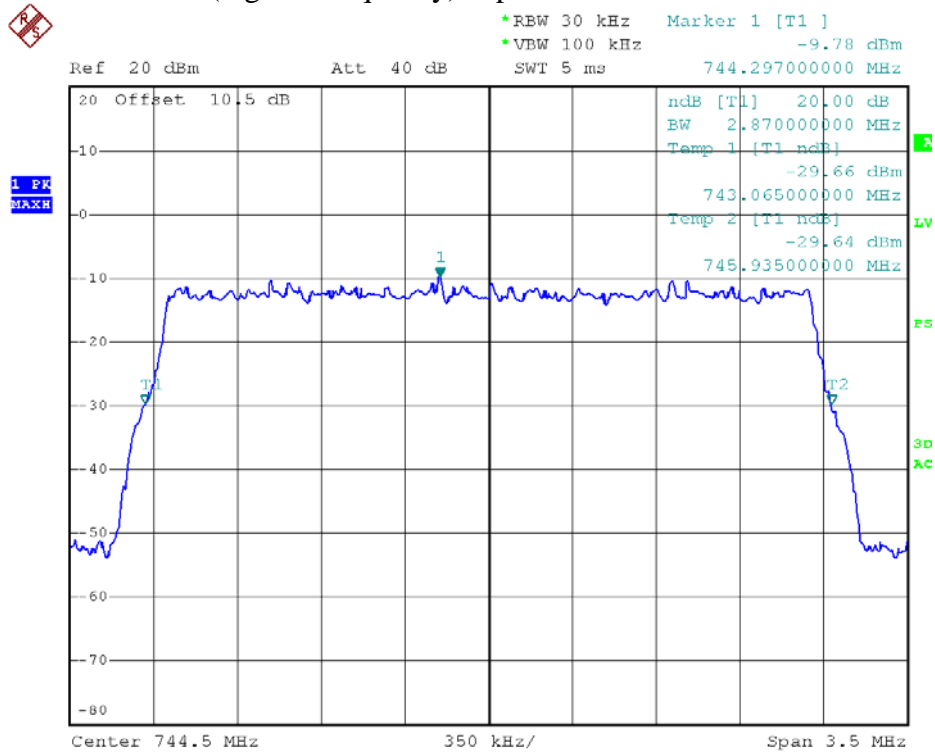

700MHz-LTE-3M downlink (highest frequency)- Output

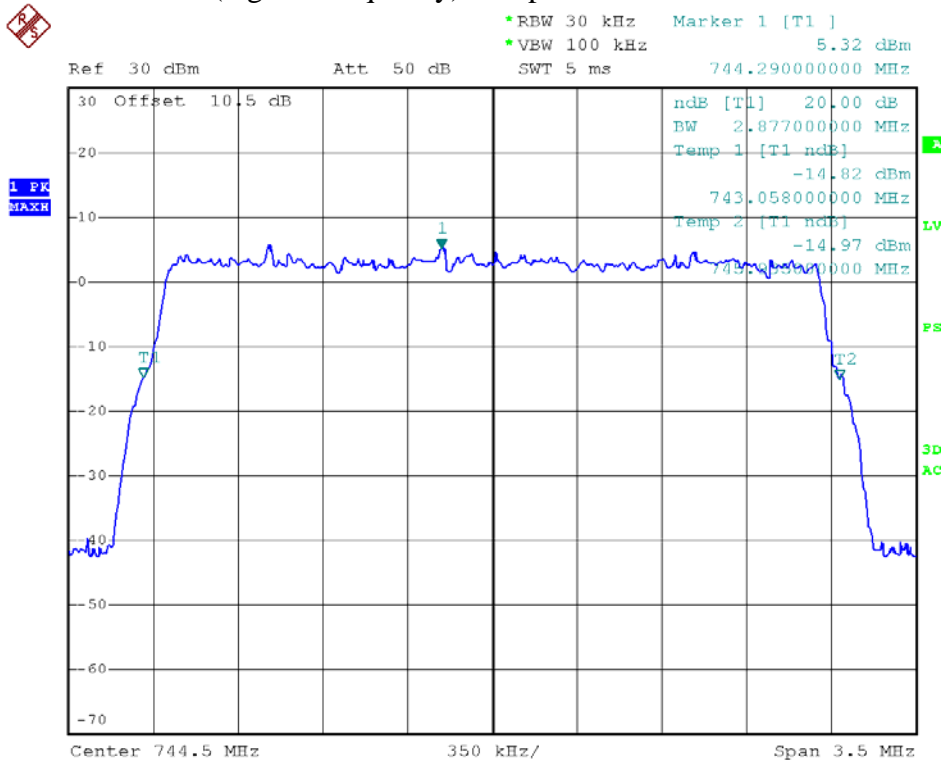

700MHz-LTE-3M uplink (lowest frequency)-Input

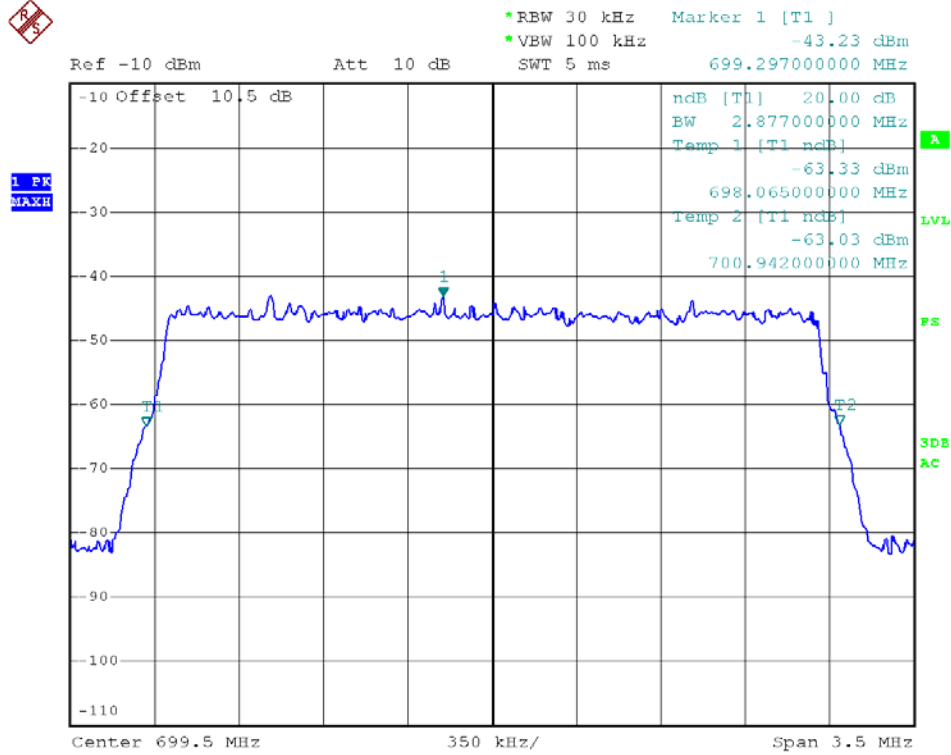

700MHz-LTE-3M uplink (lowest frequency)- Output

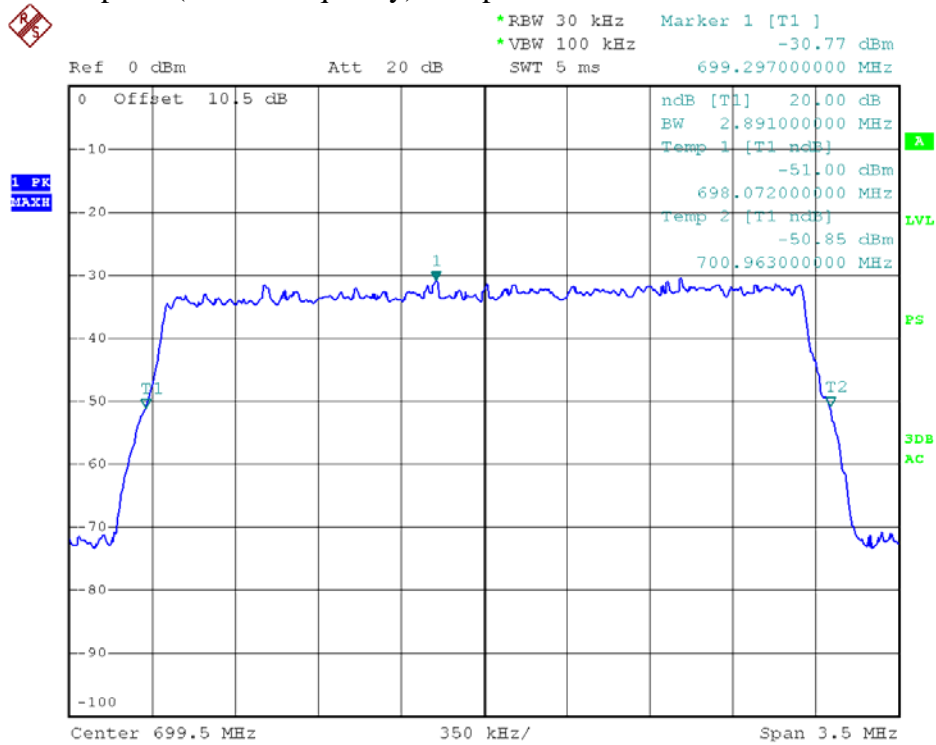

700MHz-LTE-3M uplink (middle frequency)-Input

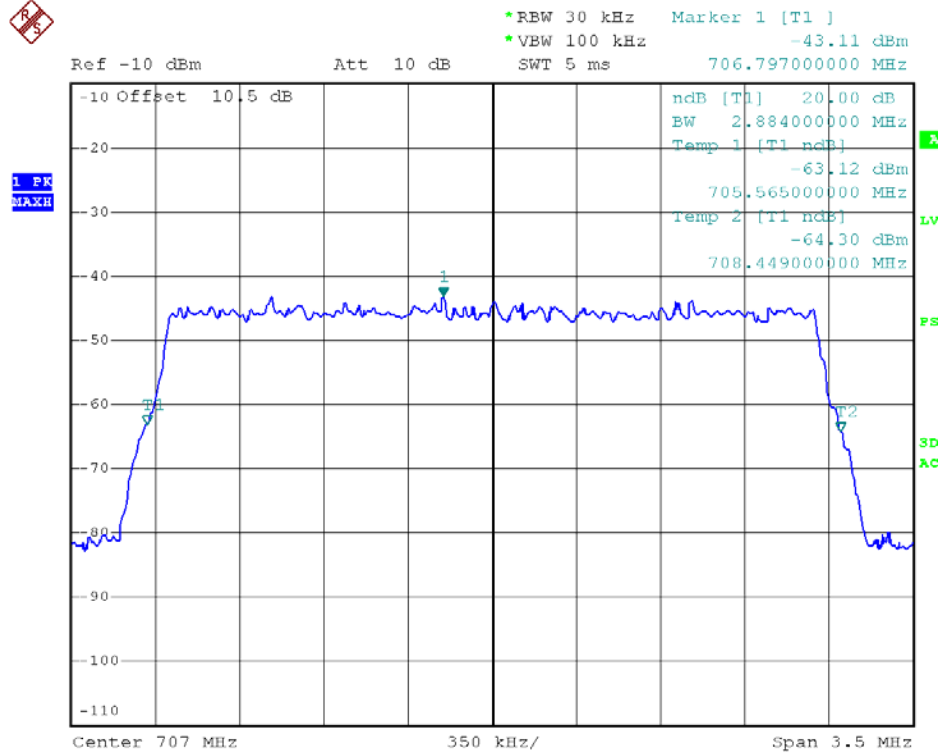

700MHz-LTE-3M uplink (middle frequency)- Output

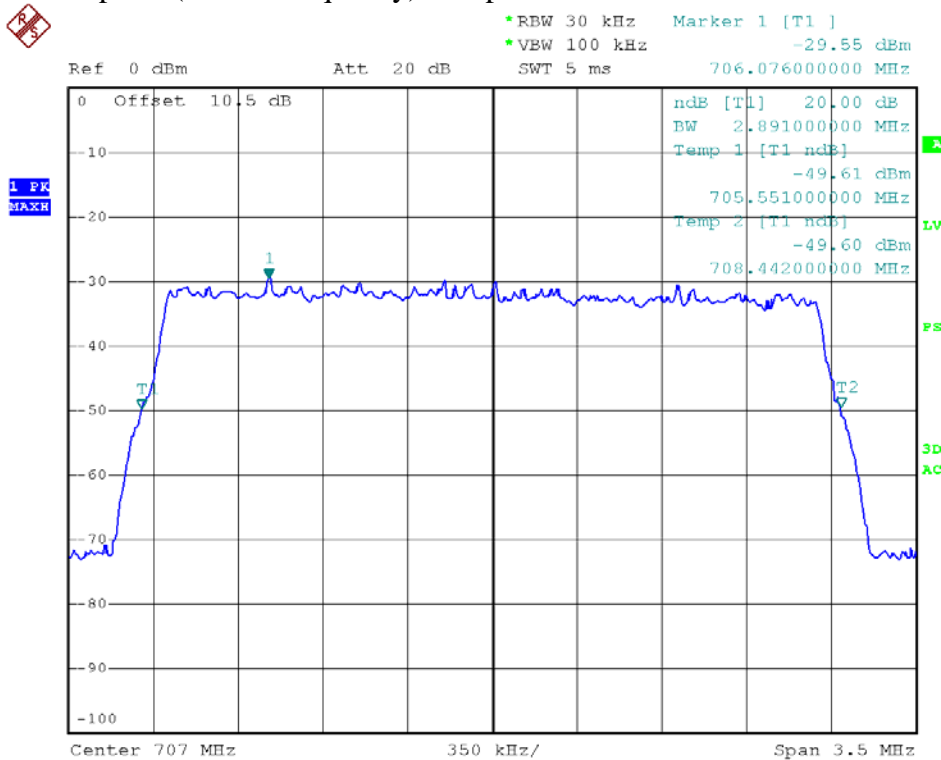

700MHz-LTE-3M uplink (highest frequency)-Input

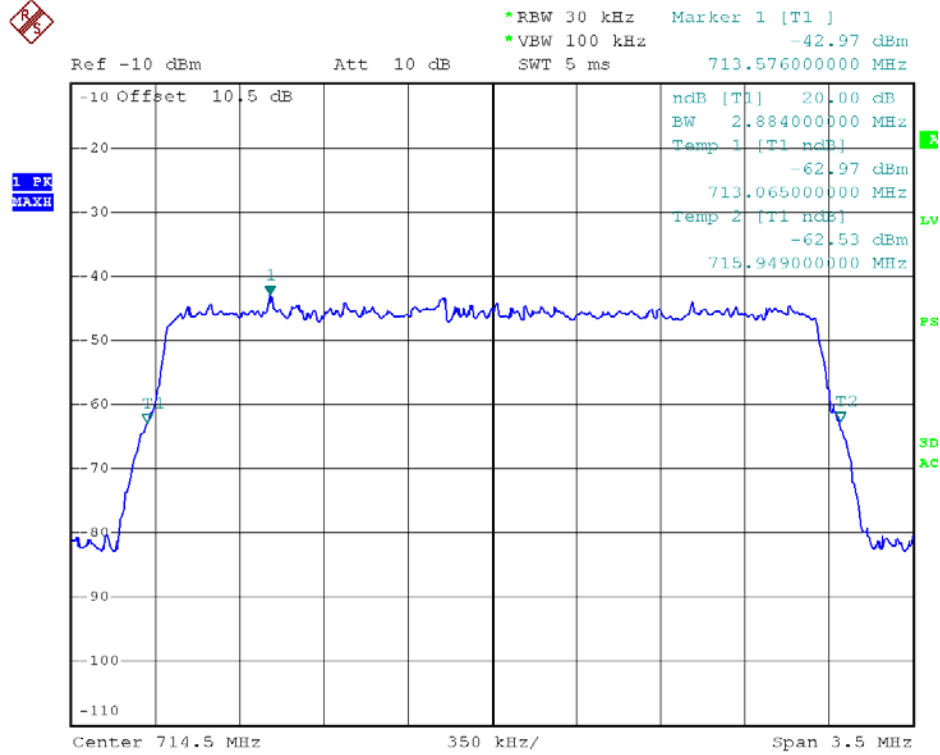

700MHz-LTE-3M uplink (highest frequency)- Output

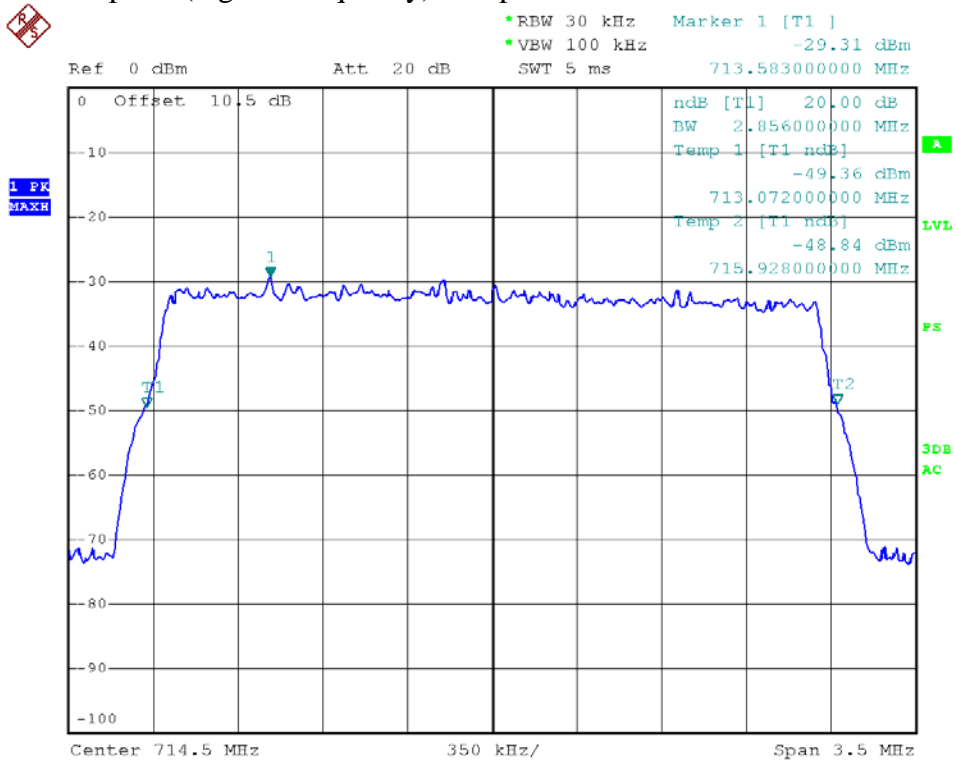

700MHz-LTE-5M downlink (lowest frequency)-Input

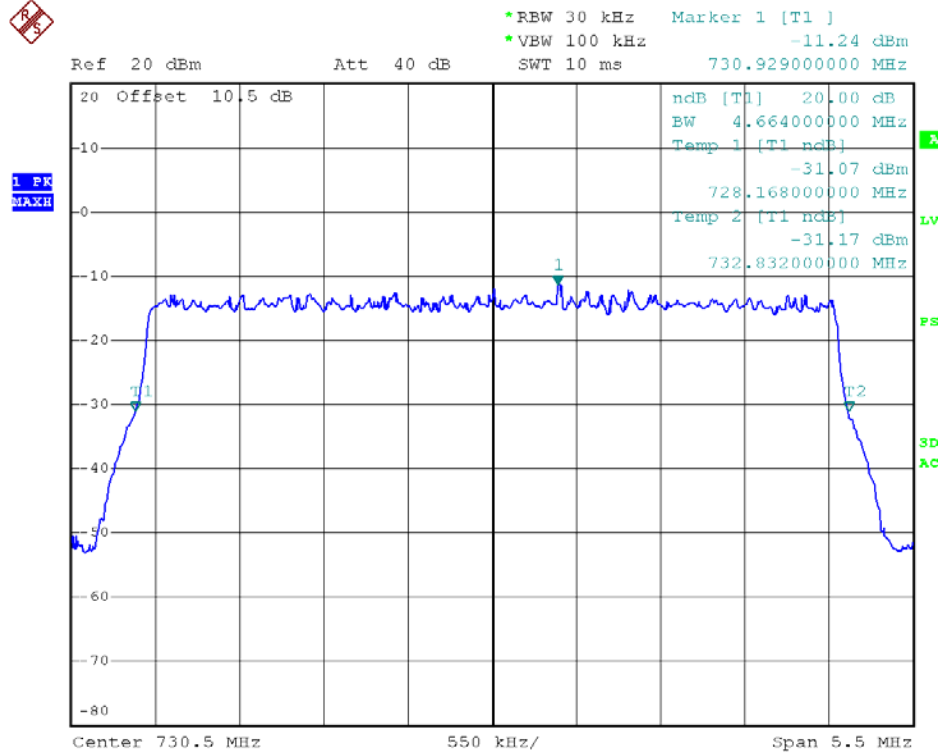

700MHz-LTE-5M downlink (lowest frequency)- Output

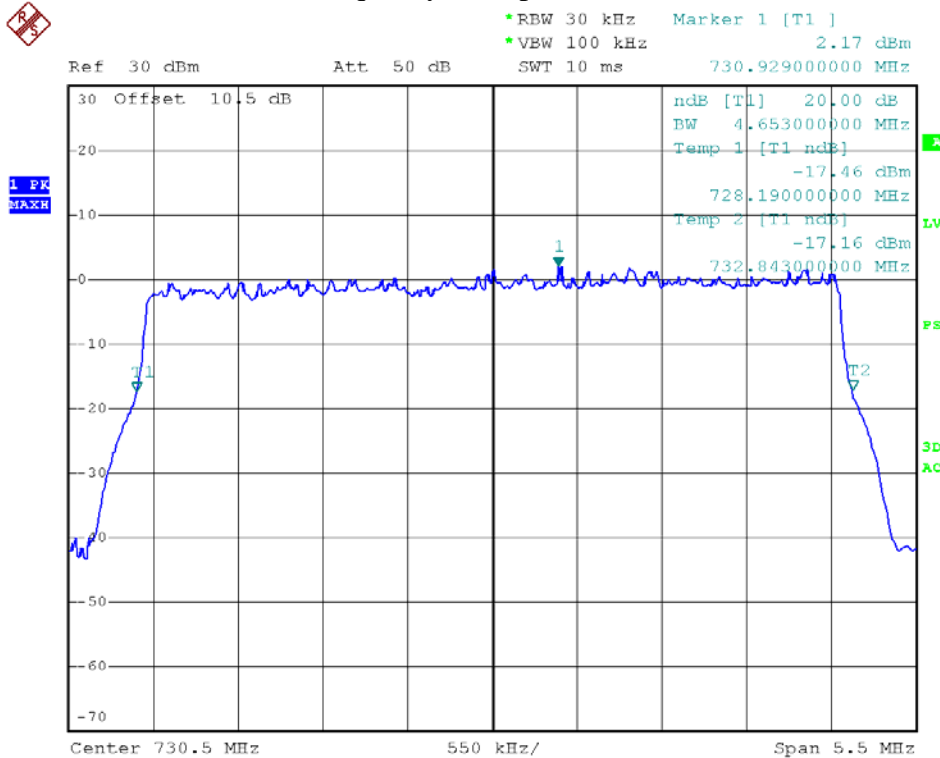

700MHz-LTE-5M downlink (middle frequency)-Input

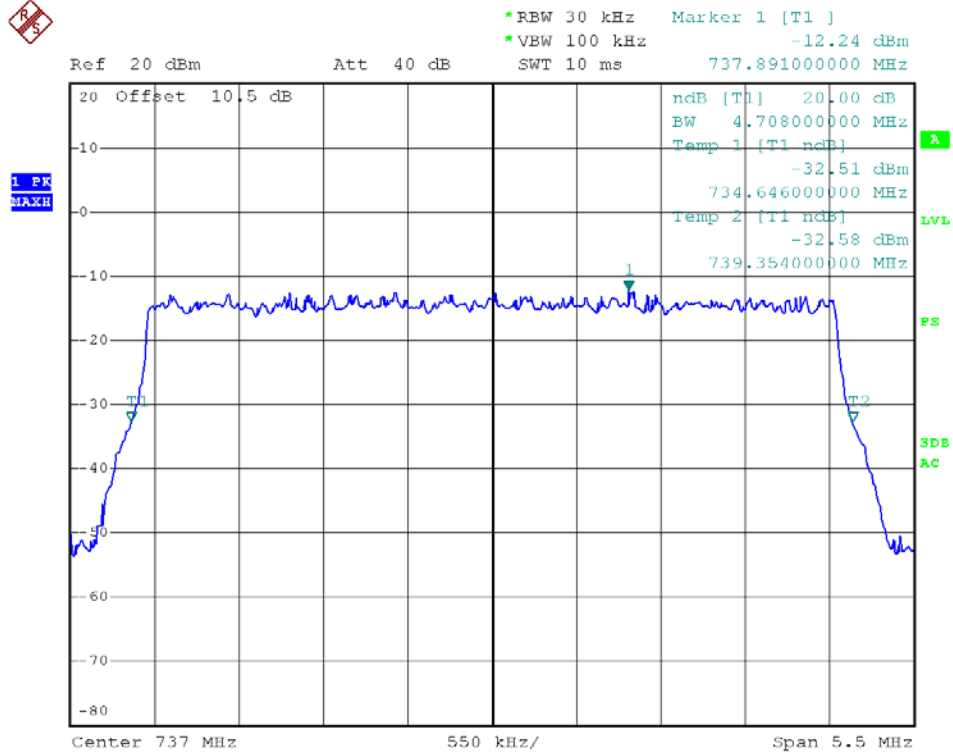

700MHz-LTE-5M downlink (middle frequency)-Output

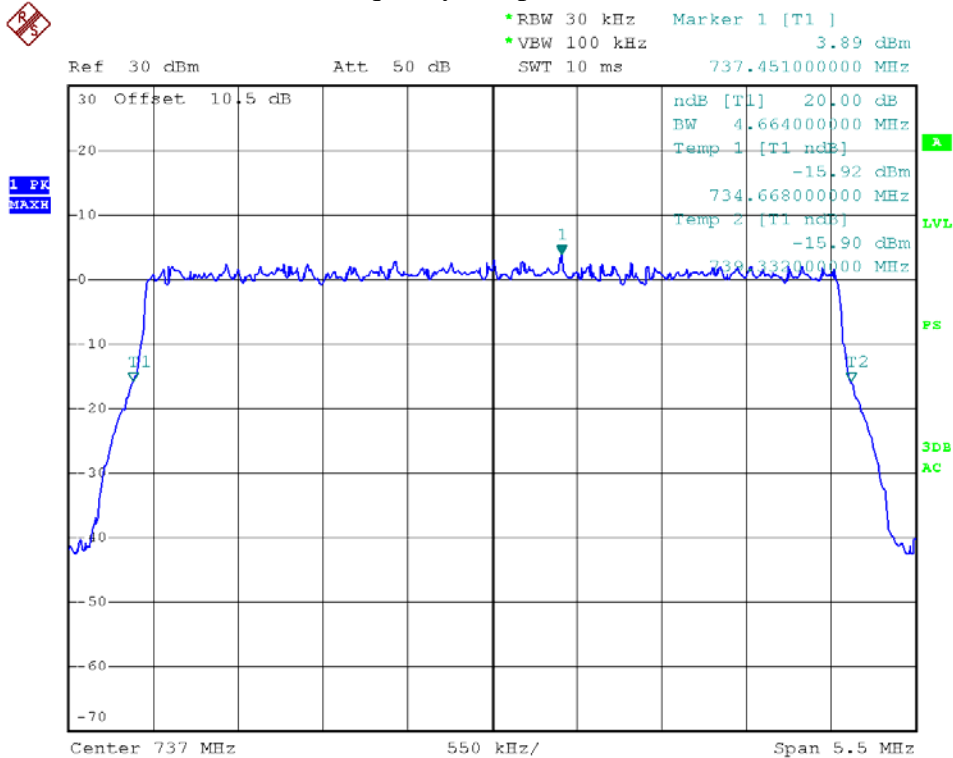

700MHz-LTE-5M downlink (highest frequency)-Input

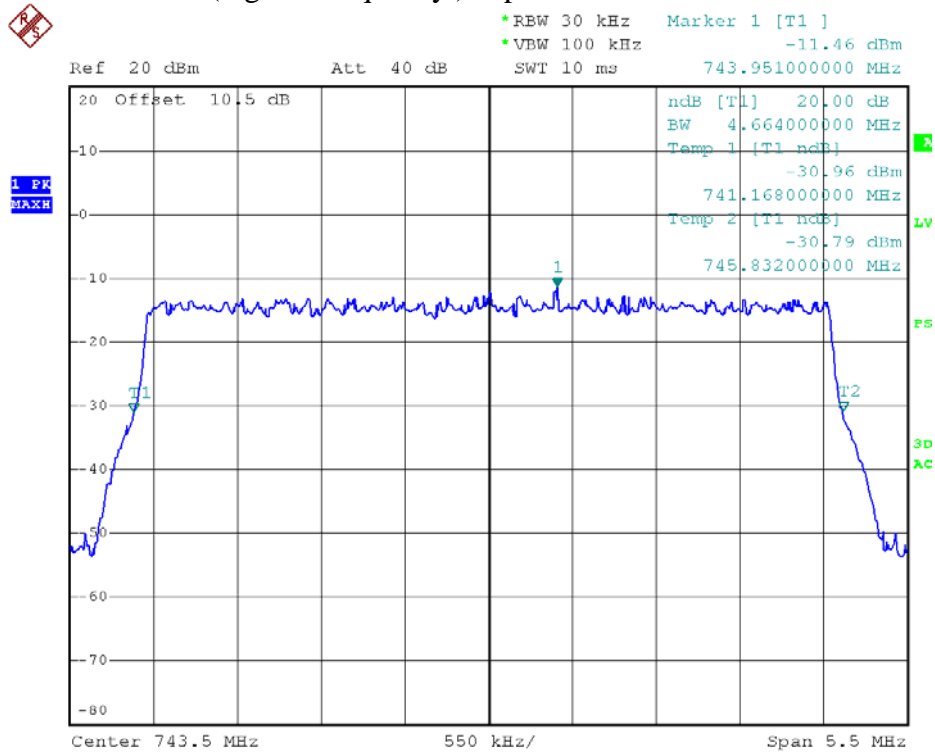

700MHz-LTE-5M downlink (highest frequency)- Output

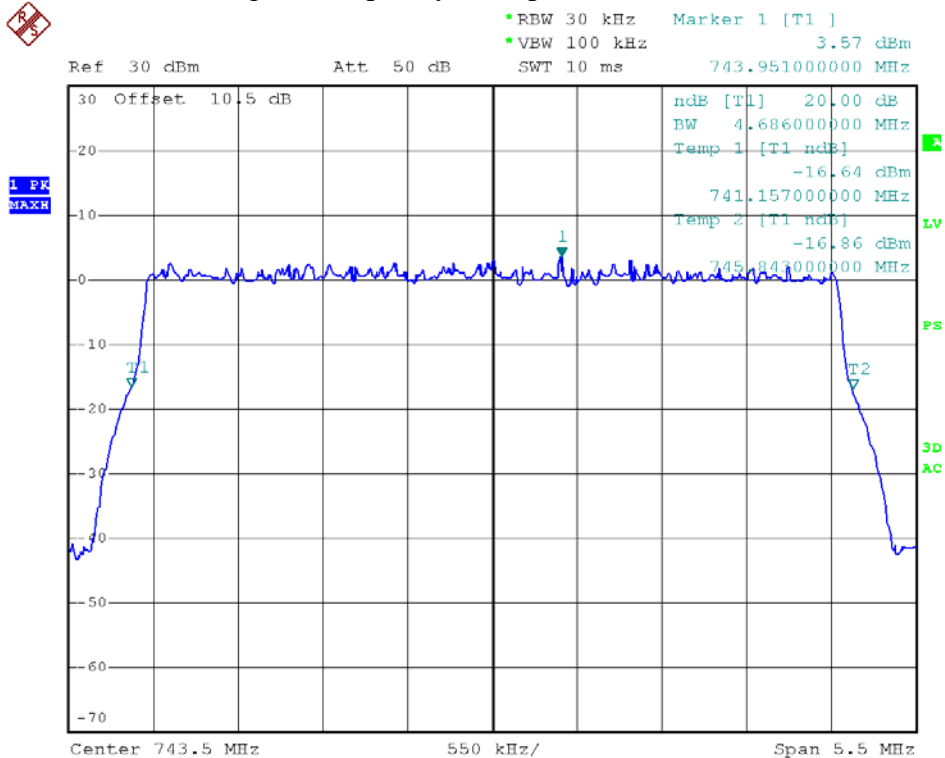

700MHz-LTE-5M uplink (lowest frequency)-Input

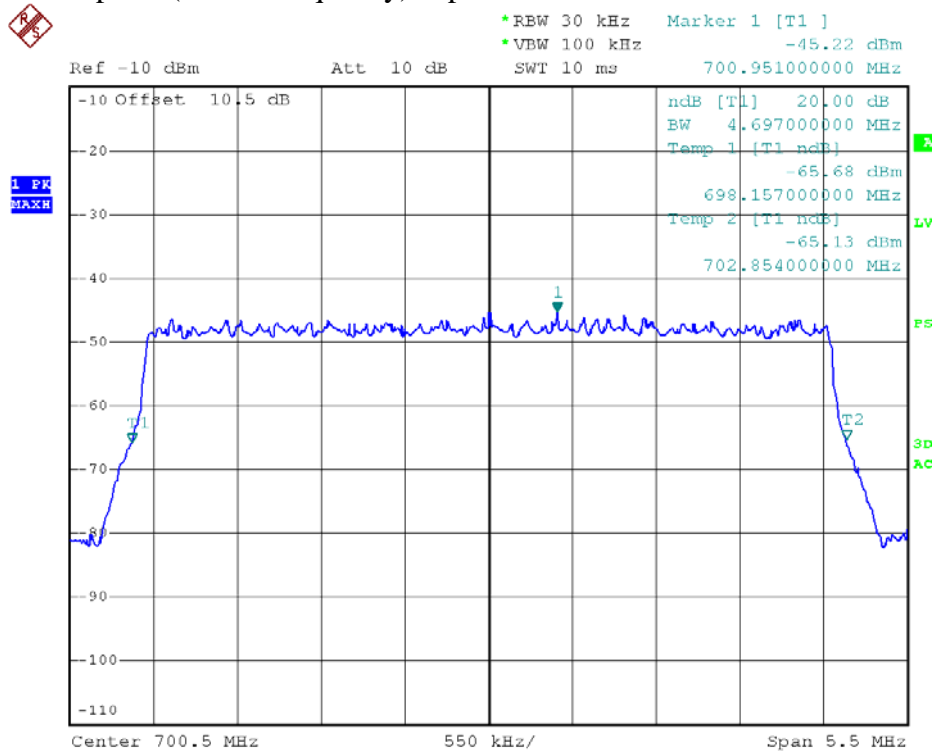

700MHz-LTE-5M uplink (lowest frequency)- Output

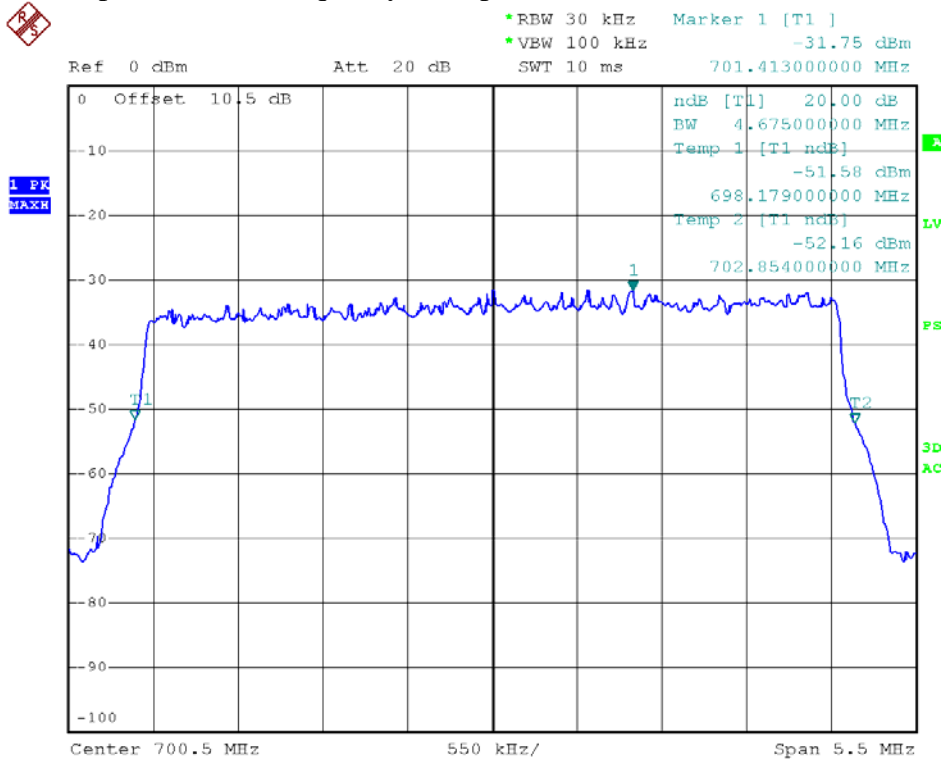

700MHz-LTE-5M uplink (middle frequency)-Input

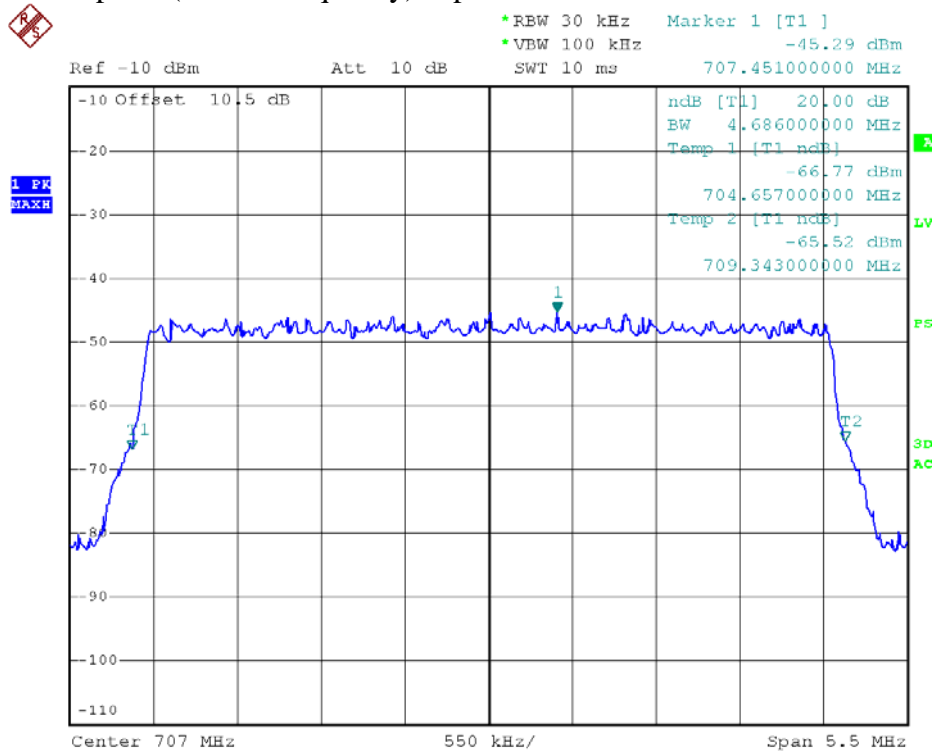

700MHz-LTE-5M uplink (middle frequency)-Output

