

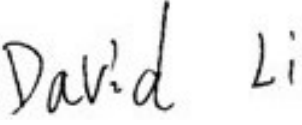



TEST REPORT

Report No.:	EM201200537	Application No.:	ZJ00020519
Client:	ADC Telecommunications, INC		
Address:	P.O. Box 1101, Minneapolis, Minnesota		
Sample Description:	InterReach Fusion 700MHz (Lower A B C) LTE, 850 MHz and 1900 MHz Multi-Band		
Model:	FSN-2-708519-1-HP		
Adding model:	FSN-2-SS-2-1P		
Test Specification:	FCC PART 22& FCC PART 24& FCC PART 27		
Issue Date:	2012-10-16		
Test Result:	<i>Pass.</i>		
Prepared By:	Reviewed By:	Approved By:	
David Li/ Test Engineer	Jane Cao/ Engineer	Gavin Wu /Manager	
			
Date:2012-10-16	Date:2012-10-16	Date:2012-10-16	
Other Aspects:			
<i>None</i>			
Abbreviations: <i>ok / P = passed; fail / F = failed; n.a. / N = not applicable</i>			
The test result in this test report refers exclusively to the presented test sample. This report shall not be reproduced except in full, without the written approval of GRGT.			

DIRECTIONS OF TEST

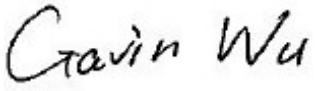
- 1. This station carries out test task according to the national regulation of verifications which can be traced to National Primary Standards and BIPM.**

- 2. The test report merely corresponds to the test sample. It is not permitted to copy extracts of these test result without the written permission of the test laboratory.**

- 3. If there is any objection concerning the test, the client should inform the laboratory within 15 days from the date of receiving the test report.**

TABLE OF CONTENTS

1 . TEST SUMMARY	4
2 . GENERAL INFORMATION	5
2.1 CLIENT INFORMATION	5
2.2 MANUFACTURER	5
2.3 BASIC DESCRIPTION OF EUT	5
2.4 STANDARDS APPLICABLE FOR TESTING.....	5
2.5 TEST LOCATION	6
2.6 ACCREDITATION.....	6
2.7 OTHER INFORMATION REQUESTED BY THE CUSTOMER	6
3 . EQUIPMENTS USED DURING TEST	7
4. TEST RESULTS	9
4.1 EUT OPERATION	9
4.2 TEST PROCEDURE & MEASUREMENT DATA	12
4.2.1 RF OUTPUT POWER.....	<u>12</u>
4.2.1.1 MEASUREMENT RECORD	14
4.2.2 CONDUCTED SPURIOUS EMISSIONS.....	<u>19</u>
4.2.2.1 MEASUREMENT RECORD	22
4.2.3 BAND EDGE	<u>25</u>
4.2.3.1 MEASUREMENT RECORD	<u>39</u>
4.2.4 RADIATED SPURIOUS EMISSIONS.....	<u>64</u>
4.2.4.1 MEASUREMENT RECORD	<u>95</u>
4.2.5 OCCUPIED BANDWIDTH.....	<u>108</u>
4.2.5.1 MEASUREMENT RECORD	<u>129</u>
4.2.6 INTERMODULATION.....	<u>158</u>
4.2.6.1 MEASUREMENT RECORD	<u>169</u>
4.2.7 OUT OF BAND REJECTION	<u>185</u>
4.2.7.1 MEASUREMENT RECORD	<u>186</u>
4.2.8 FREQUENCY STABILITY.....	<u>199</u>
4.2.8.1 MEASUREMENT RECORD	<u>298</u>
APPENDIX A:PHOTOGRAPH OF THE TEST CONFIGURATION.....	<u>296</u>
APPENDIX B: PHOTOGRAPHS OF EUT.....	303

1 . TEST SUMMARY

Test Item	Test Requirement	Test Method	Result
Output Power	FCC part 22.913 FCC part 24.232 FCC part 27.50	FCC part 2.1046 2-11-04/EAB/RF § 27.50(i) TIA/EIA 603C	PASS
Conducted Spurious Emission	FCC part 22.917 FCC part 24.238 FCC part 27.53	FCC part 2.1051 2-11-04/EAB/RF § 27.53(c) TIA/EIA 603C	PASS
Band Edge	FCC part 22.917 FCC part 24.238 FCC part 27.53	FCC part 2.1051 2-11-04/EAB/RF § 27.53(c) TIA/EIA 603C	PASS
Radiated Spurious Emission	FCC part 22.917 FCC part 24.238 FCC part 27.53	FCC part 2.1053 2-11-04/EAB/RF § 27.53(c) TIA/EIA 603C	PASS
Occupied Bandwidth	2-11-04/EAB/RF	FCC part 2.1049 2-11-04/EAB/RF 27.53(c) TIA/EIA 603C	PASS
Intermodulation	FCC part 22.917 FCC part 24.238 FCC part 27.53	2-11-04/EAB/RF TIA/EIA 603C	PASS
Out of Band Rejection	2-11-04/EAB/RF	2-11-04/EAB/RF TIA/EIA 603C	PASS
Frequency Stability	FCC part 22.355 FCC part 24.235 FCC part 27.54	FCC part 2.1055 § 27.54 TIA/EIA 603C	PASS

Remark:

Tx: In this whole report Tx (or tx) means Transmitter .

Rx: In this whole report Rx (or rx) means Receiver.

2 . GENERAL INFORMATION

2.1 CLIENT INFORMATION

Name: ADC Telecommunications, INC
Address: P.O. Box 1101, Minneapolis, Minnesota

2.2 MANUFACTURER

Name: FLEXTRONICS TECH. (SHANGHAI) CO LTD
Address: NO.77, YONG SHENG, JIADING ROAD, MALU, JIADING, SHANGHAI,
CHINA 201801

2.3 BASIC DESCRIPTION OF EUT

Equipment: InterReach Fusion 700MHz (Lower A B C) LTE,
850 MHz and 1900 MHz Multi-Band
Model No.: FSN-2-708519-1-HP
Adding model: FSN-2-SS-2-1P
Power Supply: AC 100V-240V 50-60Hz
Adapter N/A
Power Cord 1.5m unscrewed AC power cord
Type of Modulation LTE in 700MHz Lower A,B,C Band
GSM,EDGE,CDMA2000,WCDMA,LTE for Cellular Band
GSM,EDGE,CDMA2000,WCDMA,LTE for PCS Band
Frequency Band 700MHz Band :728MHz-746MHz downlink,698MHz-716MHz uplink
Celluar Band:869MHz-894MHz downlink,824MHz-849MHz uplink
PCS Band:1930MHz-1995MHz downlink ,1850MHz - 1915MHz uplink
Antenna Type N/A

2.4 STANDARDS APPLICABLE FOR TESTING

The standard used FCC part 22& FCC part 24& FCC part 27

2.5 TEST LOCATION

The tests and measurements refer to this report were performed by Guangzhou GRG Metrology and Test Technology Co., Ltd.

Add. : 163 Pingyun Rd, West of Huangpu Ave, Guangzhou, 510656, P. R. China

Telephone: +86-20-38699959, 38699960, 38699961

Fax : +86-20-38695185

2.6 ACCREDITATION

Our laboratories are accredited and approved by the following approval agencies according to ISO/IEC 17025.

USA	FCC Listed Lab No. 688188
China	CNAS NO.L0446
China	DILAC No.DL175
Canada	Registration No.:8355A-1

2.7 OTHER INFORMATION REQUESTED BY THE CUSTOMER

N/A

3 . EQUIPMENTS USED DURING TEST

Name of Equipment	Manufacturer	Model	Serial Number	Calibration Due
Radiated Spurious Emission				
Spectrum Analyzer	R&S	ESU40	100106	2013-02-04
Biconical antenna	ELECTRO-METRICS	BIA-30S	166	2014-05-26
log-periodical antenna	ELECTRO-METRICS	LPA-30	383	2014-05-26
Horn antenna	ETS.LINDGREN	3117	00075824	2013-08-19
Horn antenna	SCHWARZBECK	BBHA9120D	D752	2013-10-14
Signal Generator	R&S	SML03	103002	2013-11-14
FILTER	TELONIC	TTR95-3EE	50076	2013-09-06

Output Power/ Conducted Spurious Emission / Occupied Bandwidth/ Out of Band Rejection				
Spectrum Analyzer	R&S	ESU40	100106	2013-02-04
L.I.S.N	SCHWARZBECK	NSLK 8127	8127450	2013-08-21
Signal Generator	R&S	SML03	103002	2013-11-14

Intermodulation/ Band Edge				
signal generator	Agilent	N5182A	MY50141210	2013-09-26
signal generator	Agilent	E4438C	MY47272315	2013-09-26
Spectrum Analyzer	Agilent	E4408B	MY49652135	2013-09-26
Power splitter	Agilent	11667A	MY42254304	2013-09-02

Frequency Stability				
Constant temperature & humidity chamber	CEPREI	CEEC-MSJ-60BE	11015	2013-05-21
Spectrum Analyzer	R&S	ESU40	100106	2013-02-04
Signal Generator	R&S	SML03	103002	2013-11-14

4. TEST RESULTS

4.1 EUT OPERATION

Power supply:	AC 120V 60Hz
Temperature:	25.0 °C
Humidity:	50 % RH
Atmospheric Pressure:	1005mbar
Test requirement	

Fiber-optic distribution systems are a type of in-building radiation system that receives RF signals from an antenna, distributes the signal over fiber-optic cable, and then retransmits at another location for example within a building or tunnel. Most fiber-optic systems are signal boosters; however, some may be repeaters. These systems generally have two enclosures typically called host (or local or donor unit) and remote. Some systems may also have an optional expander box for fan-out to multiple remotes. The system transmits downlink signals from the remote unit to handsets, portables, or clients, and transmits uplink signals via from the host unit. Usually but not always the uplink goes through an intermediate amplifier to a “donor” antenna. Therefore both uplink and downlink must be tested, unless filing effectively documents how connection of uplink to donor antenna with or without an intermediate amplifier will be prevented, such as for always only a cabled connection to a base station. Fiber-optic systems are not amplifiers (AMP equipment class) – they are equipment class TNB or PCB. The same approval procedures also apply for multiple-enclosure systems connected by coax cable.

- 1) host unit
 - a) transmits uplink to base station via antenna thru coax, passive interface unit , or active interface unit (amplifier)
 - b) sends base-station downlink via fiber-optic or coax to remote
 - c) receives handset uplink via fiber-optic or coax from remote
 - d) optional connection to expansion unit via fiber-optic
 - e) separate FCC ID from remote, unless electrically identical

- f) non-transmitting host unit
- i) connects directly to a base station via coax cable but does not connect to antenna or amplifier
- ii) Part 15 digital device subject to Verification, no FCC ID
- 2) remote unit
 - a) receives base-station downlink via fiber-optic or coax from host, transmits via antenna to handsets
 - b) returns handset uplink via fiber-optic or coax to host
 - c) separate FCC ID from remote, unless electrically identical
- 3) expansion unit
 - a) fiber-optic or coax from host
 - b) fiber-optic or coax fan-out to remote(s)
 - c) Part 15 digital device subject to Verification, no FCC ID
- 4) passive interface unit
 - a) contains attenuators, splitters, combiners
 - b) coax cable connection between host and base-station
 - c) passive device, no FCC ID
- 5) active interface unit
 - a) amplifies uplink signal from host unit for transmit by donor antenna
 - b) attenuates downlink from donor antenna
 - c) coax cable connection between host and active interface unit
 - d) usually has separate FCC ID; in some cases could be combined/included with host as one enclosure

The following three general definitions follow from those stated in the Part 22, 24, and 90 rule sections as listed above. Two of the definitions replace previous EAB internal definitions given for booster, repeater and extender. The general term “extender” is the same as booster, but booster should be used rather than extender. The general term “translator” is the same as repeater, but repeater should be used rather than translator.

External radio frequency power amplifier (ERFPA) - any device which, (1) when used in conjunction with a radio transmitter signal source, is capable of amplification of that signal, and (2) is not an integral part of a radio transmitter as

manufactured. The EAS equipment class AMP is used only for an ERFPA device inserted between a transmitter (TNB/PCB) and an antenna (has only one antenna port)

Booster is a device that automatically reradiates signals from base transmitters without channel translation, for the purpose of improving the reliability of existing service by increasing the signal strength in dead spots. An “in-building radiation system” is a signal booster. These devices are not intended to extend the size of coverage from the originating base station. A booster can be either single or multiple channels.

Repeater is a device that retransmits the signals of other stations. Repeaters are different from boosters in that they can include frequency translation and can extend coverage beyond the design of the original base station. A repeater is typically single channel but can also be multiple channels.

ERFPA (AMP) and boosters/repeaters (TNB/PCB) can generally be authorized for all rule parts except 15 and 18.

Tests should be done with each typical signal. e.g., for F3E emissions use 2500 Hz with 2.5 or 5 kHz deviation. Use of CW signal for some tests is acceptable in lieu of actual emission, in some cases when CW signal gives worst case.

The EUT include Host unit, expansion unit and remote unit.

Only remote unit need FCC ID, Host unit and expansion unit do not need separate FCC ID. The EUT belongs to booster(TNB)class.

4.2 TEST PROCEDURE & MEASUREMENT DATA

4.2.1 RF OUTPUT POWER

Test Date:	16 October, 2012
Test Method:	FCC part 2.1046 2-11-04/EAB/RF
Test Requirement:	FCC part 22.913(a)& FCC part 24.232(a)&FCC 27.50 22.913(a): Maximum ERP. In general, the effective radiated power (ERP) of base transmitters and cellular repeaters must not exceed 500 Watts. 24.232(a) The power of any emission outside of the authorized operating frequency ranges must be attenuated below the transmitting power (P) by a factor of at least $43 + 10\log(P)$ dB. 27.50 the effective radiated power (ERP) of base transmitters and cellular repeaters must not exceed 1000 Watts.
EUT Operation:	The output power of EUT be set to maximum value, the gain of EUT be set to maximum value by software through the manufacture
Status:	Normal
Conditions:	700MHz DL and UL ports,850MHz DL and UL ports, 1900MHz DL and UL ports
Test configuration:	

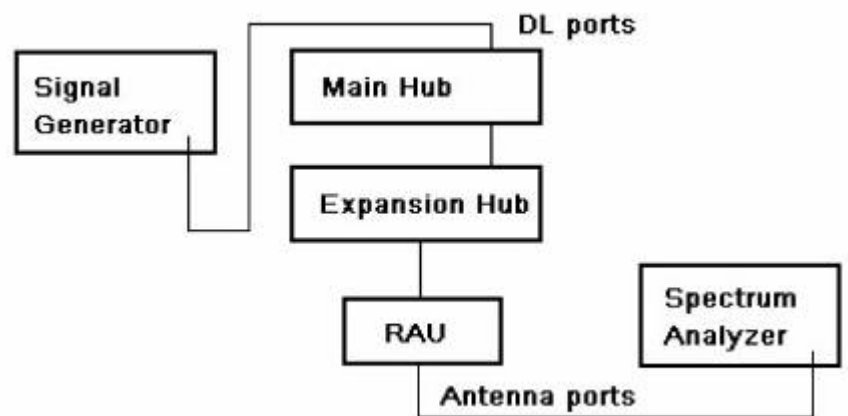

Fig.1 Down Link Configuration

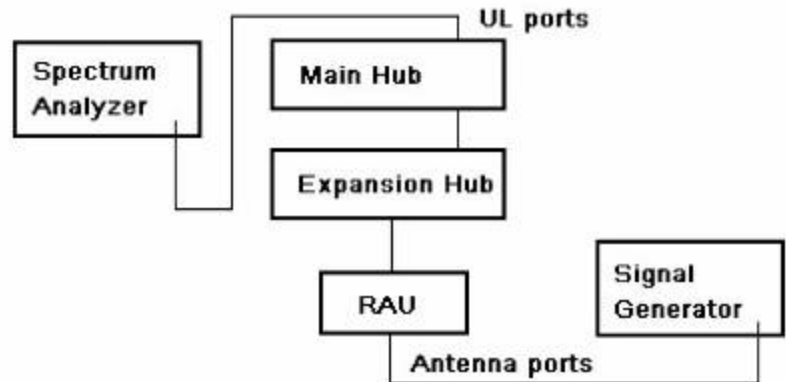

Fig.2 Up Link Configuration

Test Procedure:

RF out put power test procedure: **(Conducted measurement)**

- a) Connect the equipment as illustrated, when the output power is over the max value of the Spectrum Analyzer, add the attenuator to avoid destroying the facility.
- b) Set the center frequency of the Spectrum Analyzer to the assigned transmitter frequency, key the transmitter ,and set the level of the carrier to the full scale reference line.
- c) Do not apply any tone to modulate the EUT
- d) Adjust the Spectrum Analyzer for the following setting :
 - 1) Resolution Bandwidth \gg the carrier bandwidth
 - 2) Video Bandwidth refer to standard requirement
- e) Use spectrum analyzer channel power measurement
- f) Record the frequencies and levels of carrier power
- g) Calculate the signal link way loss and final power value

Remark:

Output power:

Power on Form 731 should be clearly understood as either composite of multichannels or per carrier, If power is composite

Include in comments field: "Power output listed is composite for multi-channel operation."

Check that the input drive level is at the maximum input rating and maximum gain setting for all tests. Check both uplink and downlink input level. See manual or brochures/technical description for maximum rating. May need to check FCC identifier of transmitter used for tests.

Confirm device cannot operate in saturation .Are there means to control maximum power and to assure linear operation (use in system configuration may be necessary) ? How is saturation or over-modulation prevented for pulsed signal inputs?

4.2.1.1 MEASUREMENT RECORD

700MHz Band:

Frequency Band (728MHz-746MHz),Measure Max Out put power (dBm)	
LTE(1.4MHz)	
728.70 MHz	17.82
737.00 MHz	17.96
745.30 MHz	17.91
Max value in W	
0.063	
LTE(3MHz)	
729.50 MHz	17.84
737.00 MHz	18.06
744.50 MHz	17.93
Max value in W	
0.064	
LTE(5MHz)	
730.50 MHz	17.86
737.00 MHz	18.15
743.50 MHz	17.89
Max value in W	
0.065	
LTE(10MHz)	
733.00 MHz	17.92
737.00 MHz	18.22
741.00 MHz	17.87
Max value in W	
0.066	

850MHz Band:

Frequency Band (869MHz-894MHz),Measure Max Out put power (dBm)	
GSM(300KHz)	
869.20 MHz	25.84
881.60 MHz	26.04
893.80 MHz	25.88
Max value in W	
0.402	
EDGE(300KHz)	
869.20 MHz	22.86
881.60 MHz	23.12
893.80 MHz	22.91
Max value in W	
0.205	
CDMA200(1.25MHz)	
869.70 MHz	17.85
881.52 MHz	18.06
893.31 MHz	17.92
Max value in W	
0.064	
WCDMA(5MHz)	
871.40 MHz	17.82
881.50 MHz	18.12
891.60 MHz	17.89
Max value in W	
0.065	

Frequency Band (869MHz-894MHz),Measure Max Out put power (dBm)	
LTE(1.4MHz)	
869.70 MHz	17.84
881.50 MHz	17.95
893.30 MHz	17.92
Max value in W	
0.062	
LTE(3MHz)	
870.50 MHz	17.86
881.50 MHz	18.08
892.50 MHz	17.94
Max value in W	
0.064	
LTE(5MHz)	
871.50 MHz	17.89
881.50 MHz	18.16
891.50 MHz	17.92
Max value in W	
0.065	
LTE(10MHz)	
874.00 MHz	17.87
881.50 MHz	18.21
889.00 MHz	17.89
Max value in W	
0.066	

1900MHz Band :

Frequency Band (1930MHz-1995MHz),Measure Max Out put power (dBm)	
GSM(300KHz)	
1930.20 MHz	25.86
1962.60 MHz	26.08
1994.80 MHz	25.90
Max value in W	
0.406	
EDGE(300KHz)	
1930.20 MHz	25.84
1962.60 MHz	26.12
1994.80 MHz	25.92
Max value in W	
0.409	
CDMA200(1.25MHz)	
1931.25 MHz	22.87
1962.50 MHz	23.06
1993.75MHz	22.89
Max value in W	
0.202	
WCDMA(5MHz)	
1932.40 MHz	22.90
1962.50 MHz	23.25
1992.60MHz	22.93
Max value in W	
0.211	

Frequency Band (1930MHz-1995MHz),Measure Max Out put power (dBm)	
LTE(1.4MHz)	
1930.70 MHz	22.84
1962.50 MHz	22.94
1994.30 MHz	22.75
Max value in W	
0.196	
LTE(3MHz)	
1931.50 MHz	22.87
1962.50 MHz	23.04
1993.50 MHz	22.89
Max value in W	
0.201	
LTE(5MHz)	
1932.50 MHz	22.82
1962.50 MHz	23.12
1992.50 MHz	22.86
Max value in W	
0.205	
LTE(10MHz)	
1935.00 MHz	22.85
1962.50 MHz	23.24
1990.00 MHz	22.92
Max value in W	
0.210	

Remark: test in single channel status, output power is test in full amplifying status

4.2.2 CONDUCTED SPURIOUS EMISSIONS

Test Date: 16 October, 2012
 Test Method: FCC part 2.1051

Test Requirement: FCC part 22.917(a)& FCC part 24.238(a)&FCC 27.53
 22.917(a): The power of any emission outside of the authorized operating frequency ranges must be attenuated below the transmitting power (P) by a factor of at least $43 + 10\log(P)$ dB.
 24.238(a) The power of any emission outside of the authorized operating frequency ranges must be attenuated below the transmitting power (P) by a factor of at least $43 + 10\log(P)$ dB.
 27.53 The power of any emission outside of the authorized operating frequency ranges must be attenuated below the transmitting power (P) by a factor of at least $43 + 10\log(P)$ dB.

Status The output power of EUT be set to maximum value ,the gain of EUT be set to maximum value by software through the manufacture

Conditions Normal

Application 700MHz DL and UL ports,850MHz DL and UL ports, 1900MHz DL and UL ports

Test configuration

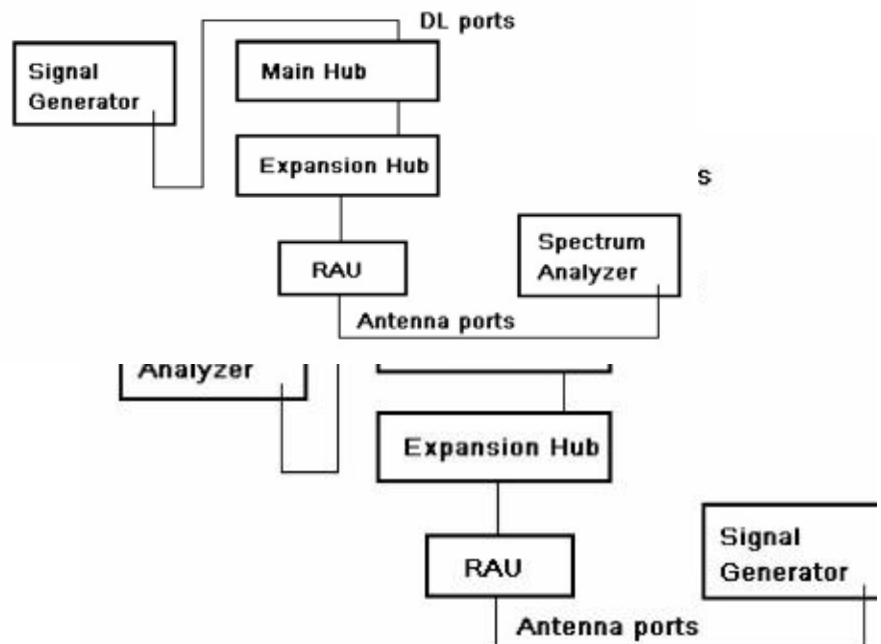

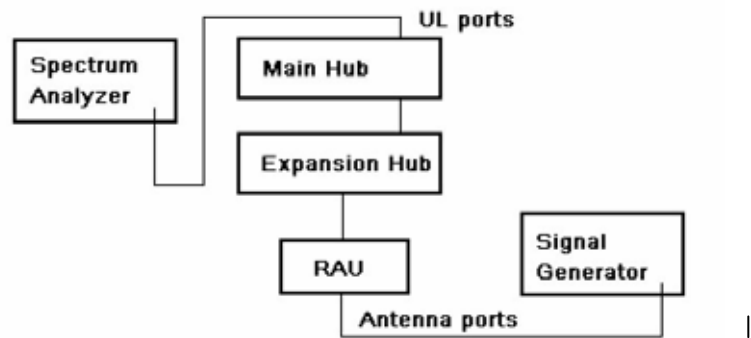
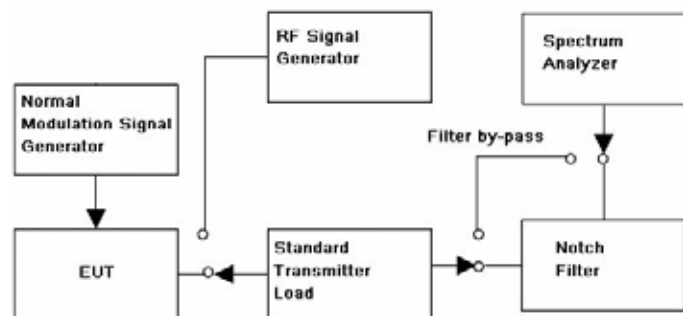

Fig.2 Up Link Configuration

Test Procedure:



Conducted Emission test procedure:

- a) Connect the equipment as illustrated, when the output power is over the max value of the Spectrum Analyzer, add the attenuator to avoid destroying the facility.
- b) Set the center frequency of the Spectrum Analyzer to the assigned transmitter frequency, key the transmitter, and set the level of the carrier to the full scale reference line.
- c) Do not apply any tone to modulate the EUT
- d) Adjust the Spectrum Analyzer for the following setting :
 - 1) Resolution Bandwidth, (base the standard, apply the different set). here is 100KHZ for frequency band less than 1GHZ, 1MHz for frequency over 1GHZ;
 - 2) Video Bandwidth refer to standard requirement
- e) Adjust the center frequency of the spectrum analyzer for incremental coverage of the range from:

Use spectrum analyzer channel power measurement

 - 1) the lowest radio frequency generated in the equipment, it can be 9KHZ base the test method, here select 30MHz as lowest frequency start point;
 - 2) the highest radio frequency shall higher than 10 times of carrier frequency.
- f) Record the frequencies and levels of carrier power

Remark

The notch filter is used for avoid the EUT fundamental carrier output power making the spectrum overload and the harmonic spurious brought it.

When the EUT fundamental carrier is not enough to make the status ,the notch filter could be not used.

4.2.2.1 MEASUREMENT RECORD

700MHz Band

700MHz-LTE-QPSK downlink (lowest frequency) 30MHz-1GHz

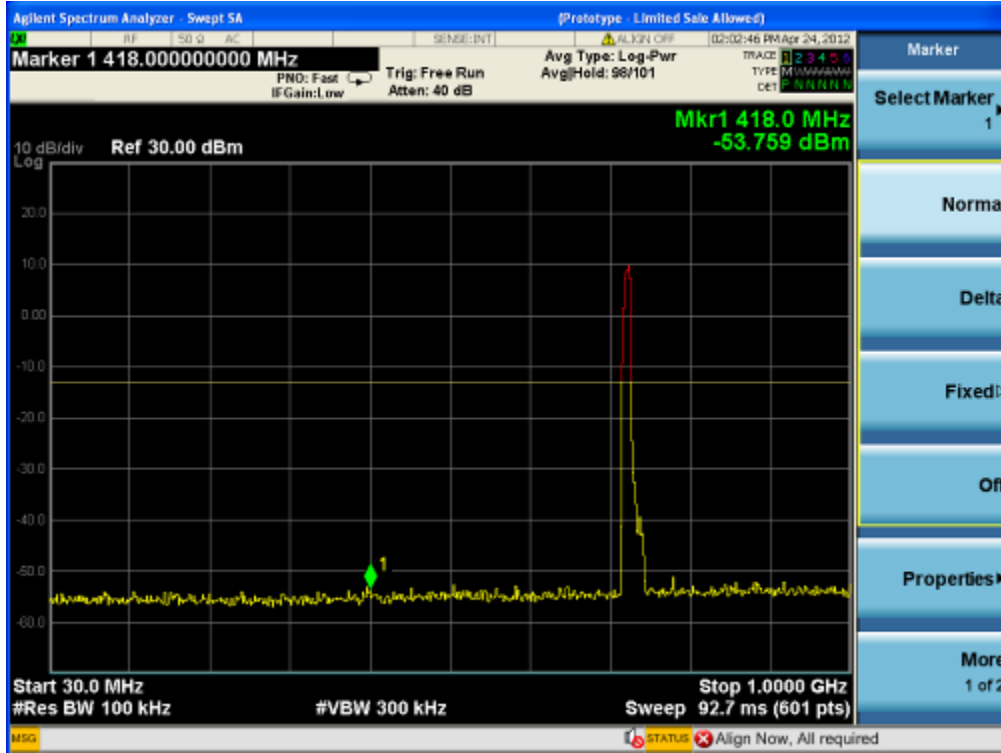

700MHz -LTE-QPSK downlink (lowest frequency) Above 1GHz

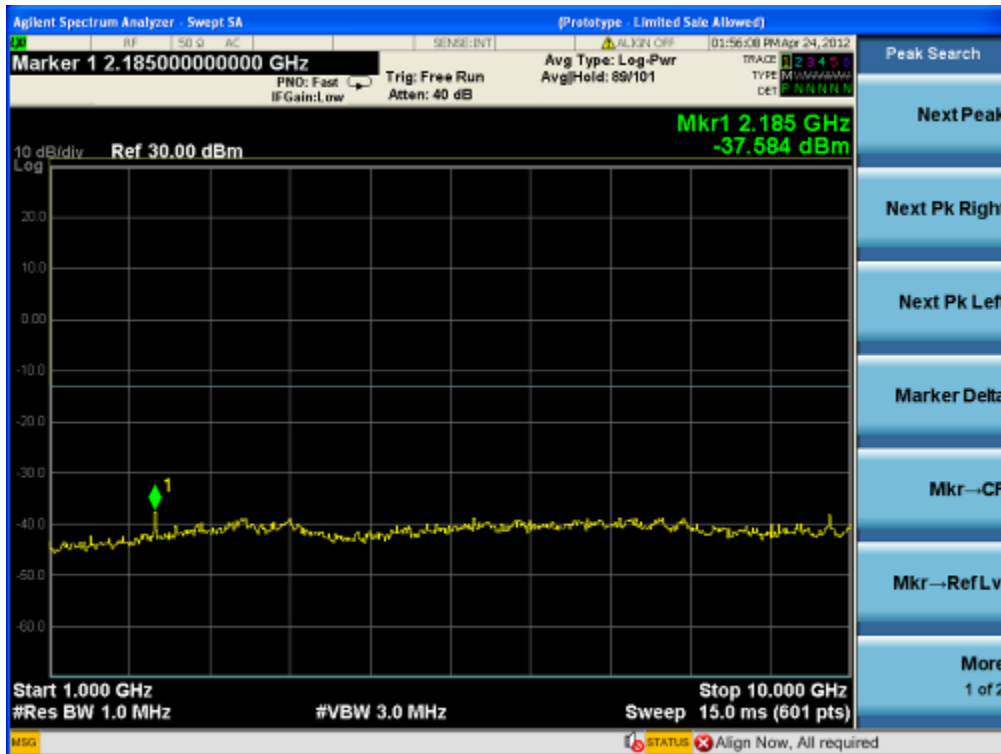

700MHz -LTE-QPSK downlink (middle frequency) 30MHz-1GHz

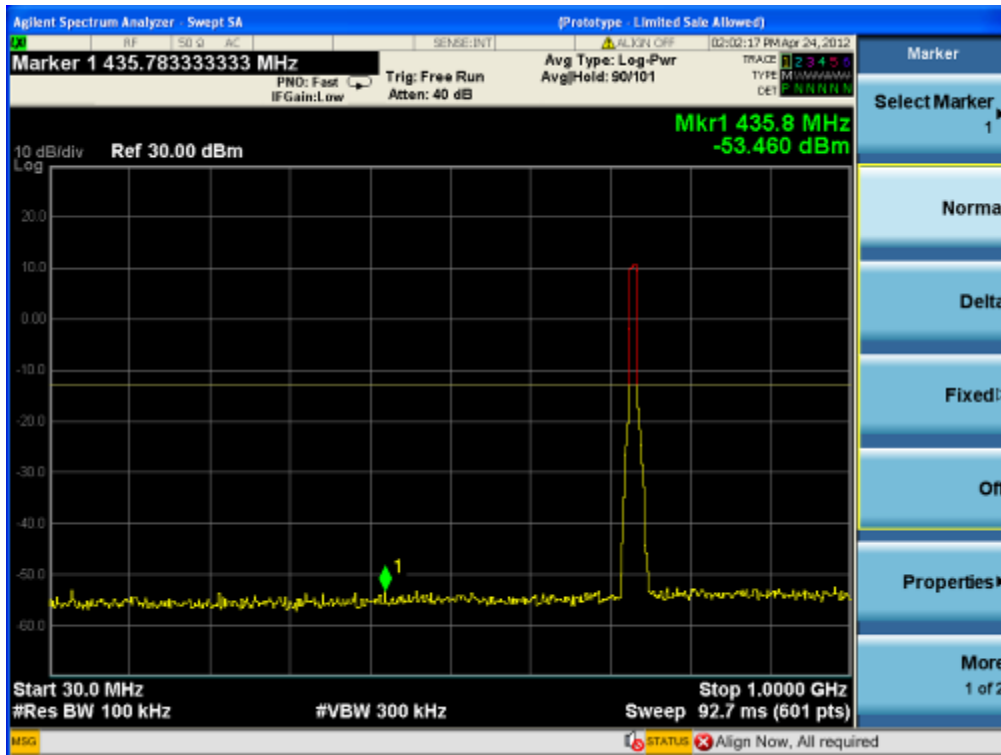

700MHz -LTE-QPSK downlink (middle frequency) Above 1GHz



700MHz -LTE-QPSK downlink (highest frequency) 30MHz-1GHz

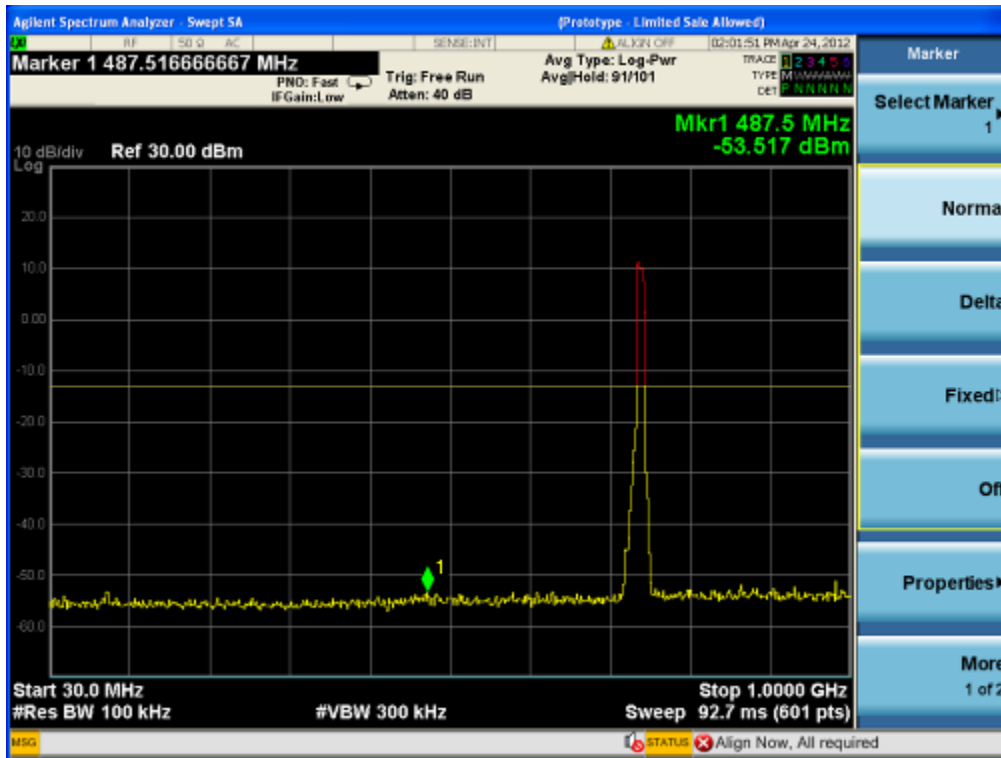

700MHz -LTE-QPSK downlink (highest frequency) Above 1GHz



700MHz -LTE-QPSK uplink (lowest frequency) 30MHz-1GHz

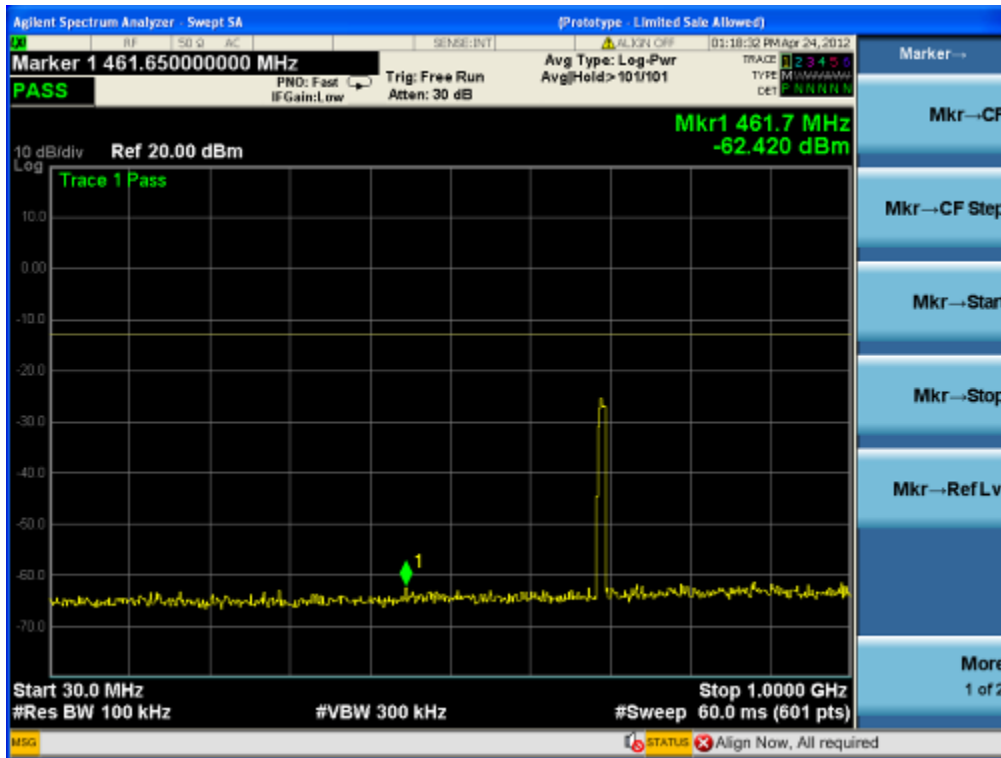

700MHz -LTE-QPSK uplink (lowest frequency) Above 1GHz

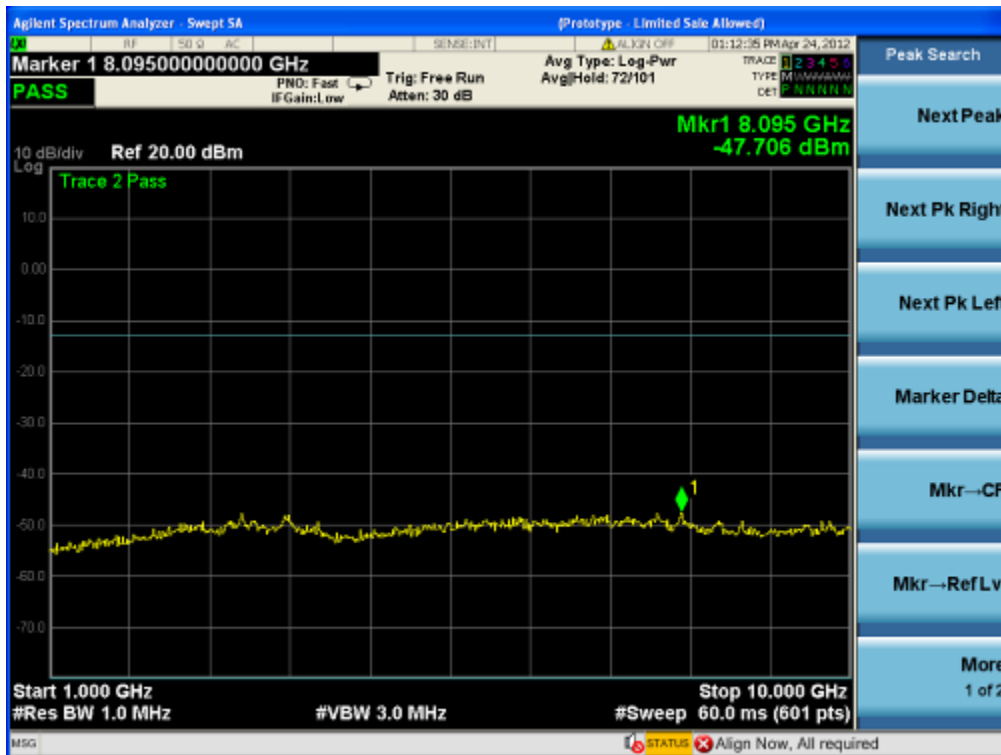

700MHz -LTE-QPSK uplink (middle frequency) 30MHz-1GHz

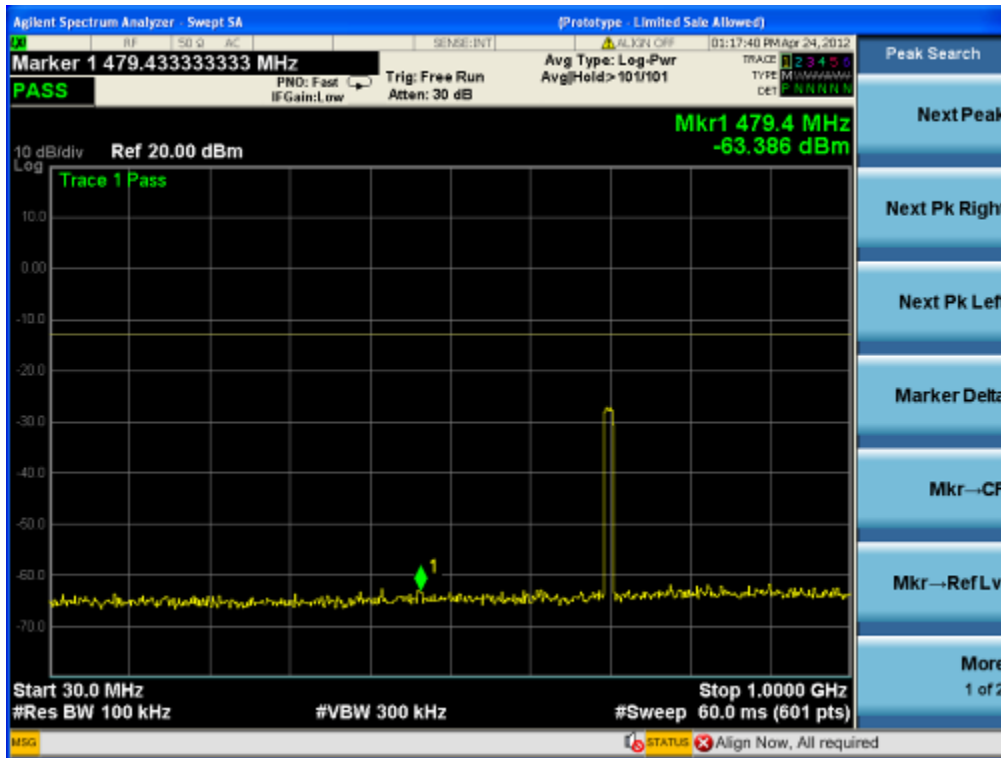

700MHz -LTE-QPSK uplink(middle frequency) Above 1GHz

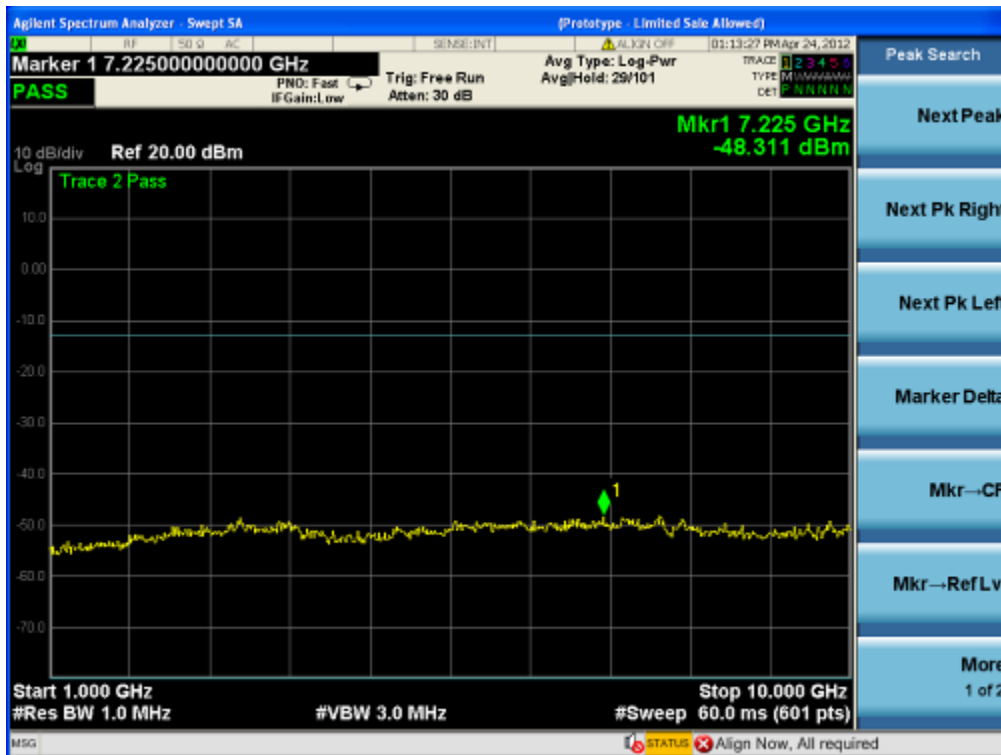

700MHz -LTE-QPSK uplink (highest frequency) 30MHz-1GHz

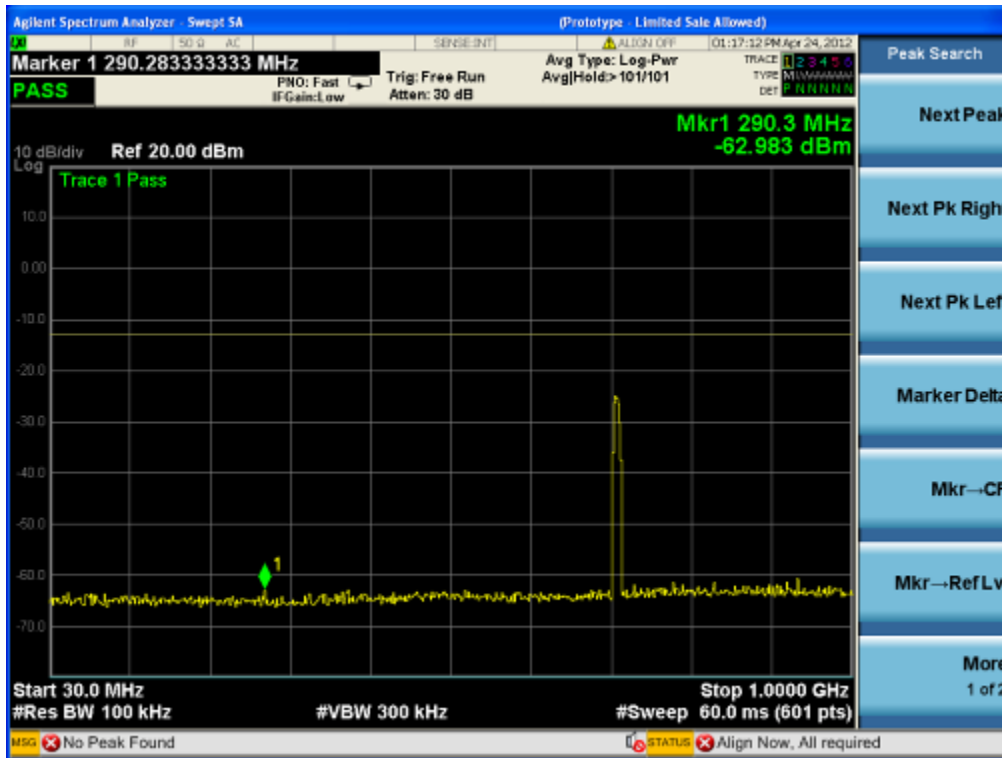

700MHz -LTE-QPSK uplink (highest frequency) Above 1GHz

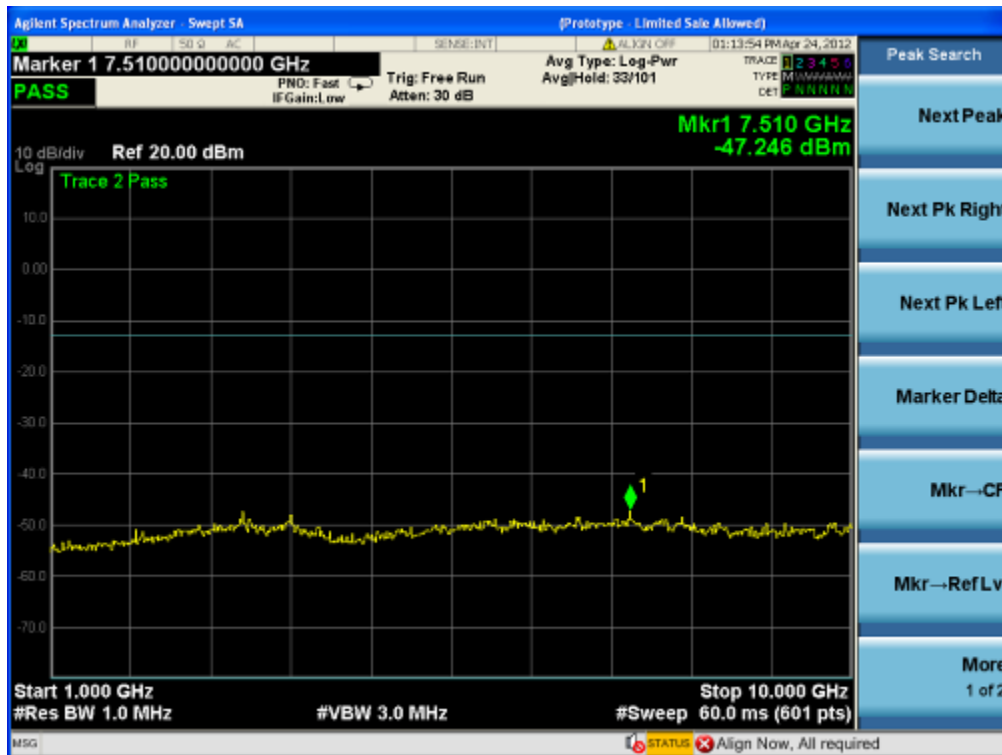

700MHz-LTE-16QAM downlink (lowest frequency) 30MHz-1GHz

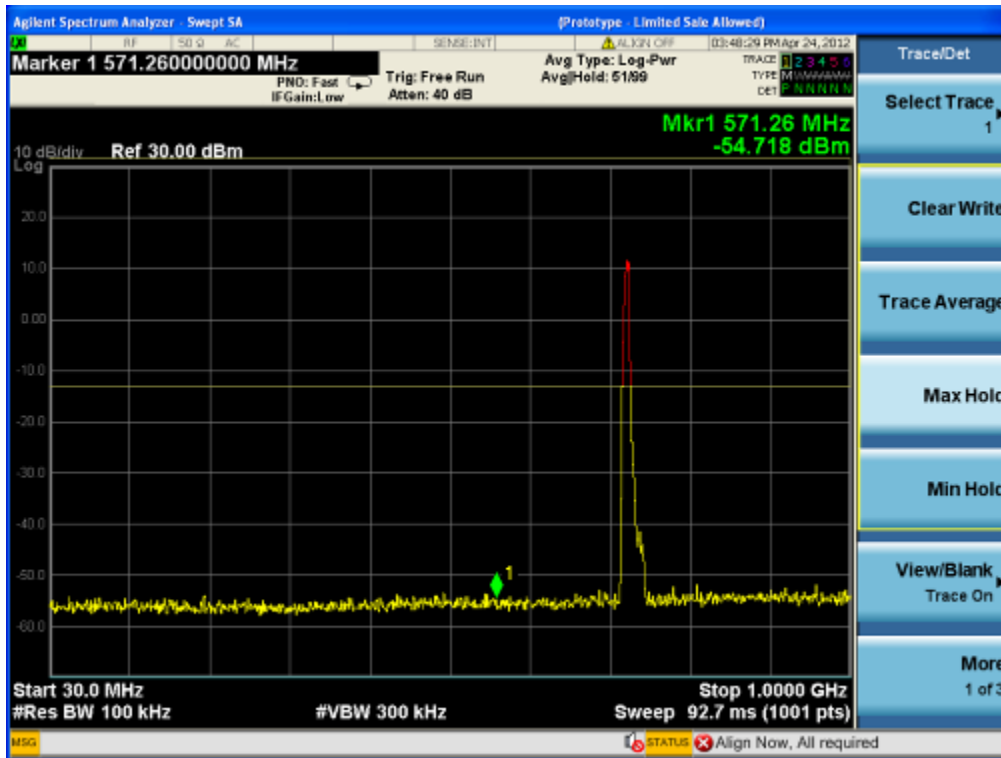

700MHz -LTE-16QAM downlink (lowest frequency) Above 1GHz

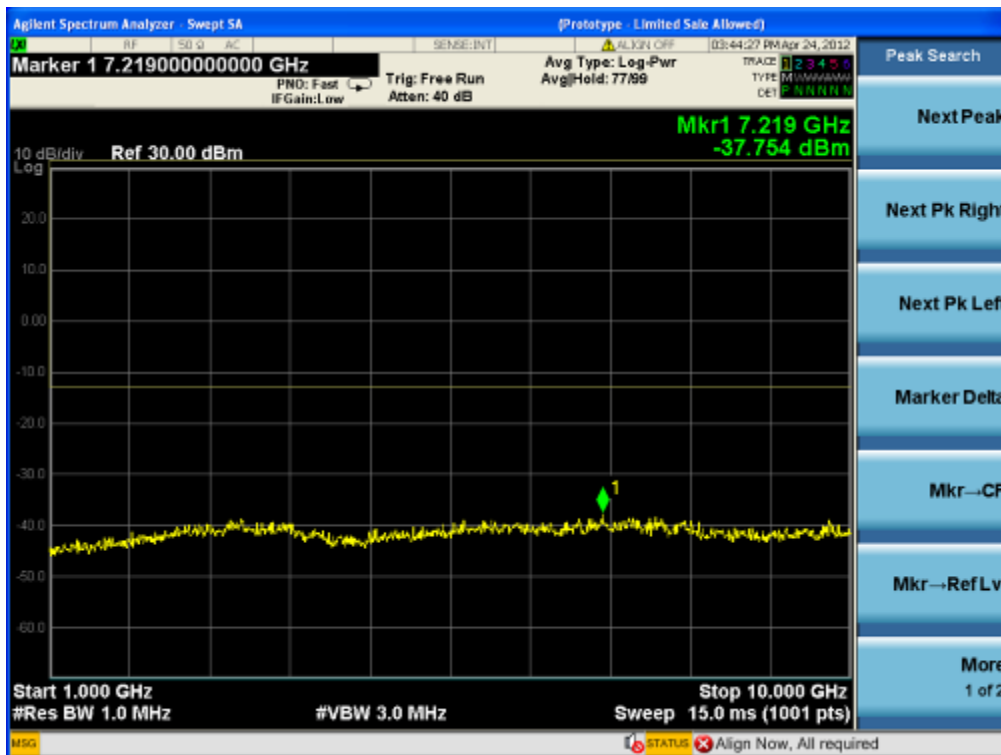

700MHz -LTE-16QAM downlink (middle frequency) 30MHz-1GHz

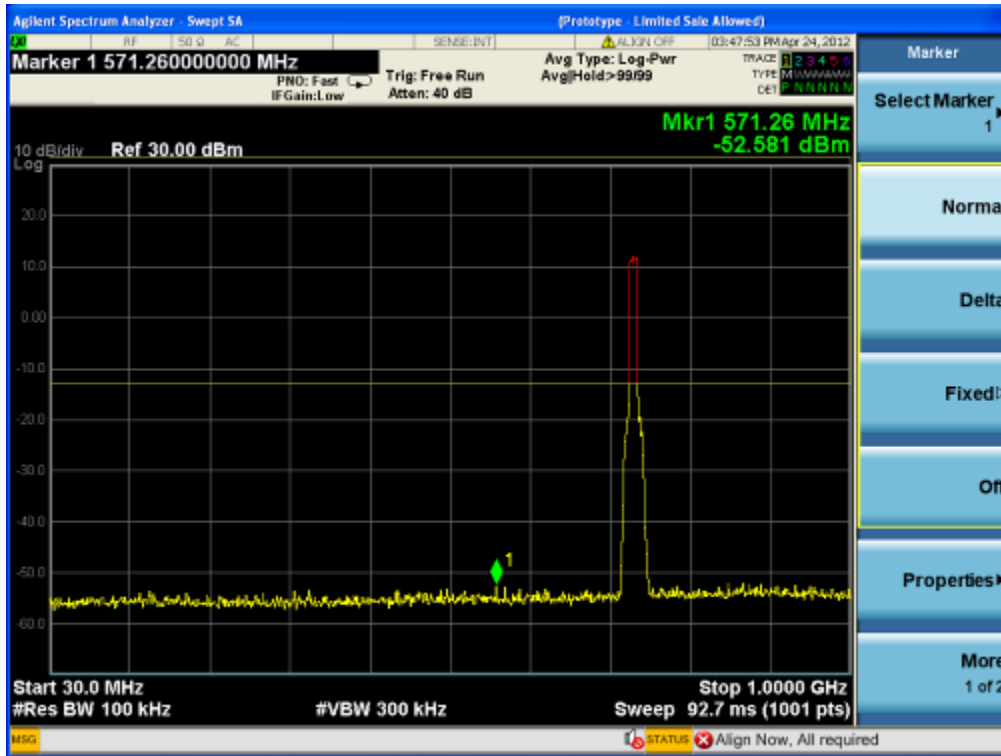

700MHz -LTE-16QAM downlink (middle frequency) Above 1GHz

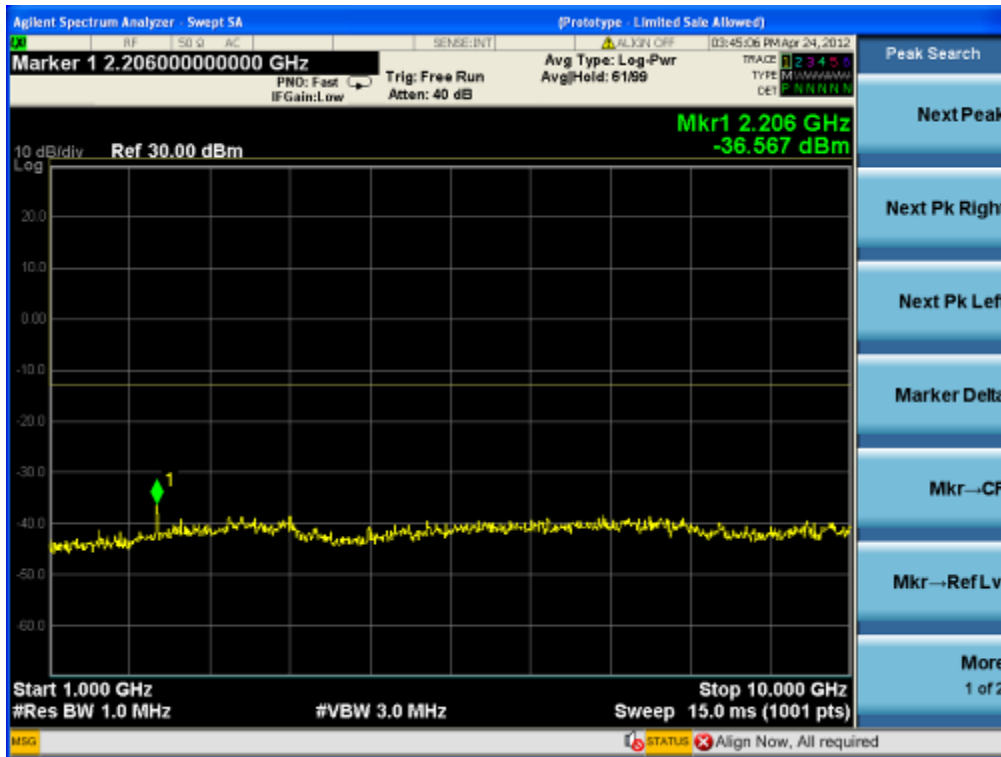

700MHz -LTE-16QAM downlink (highest frequency) 30MHz-1GHz

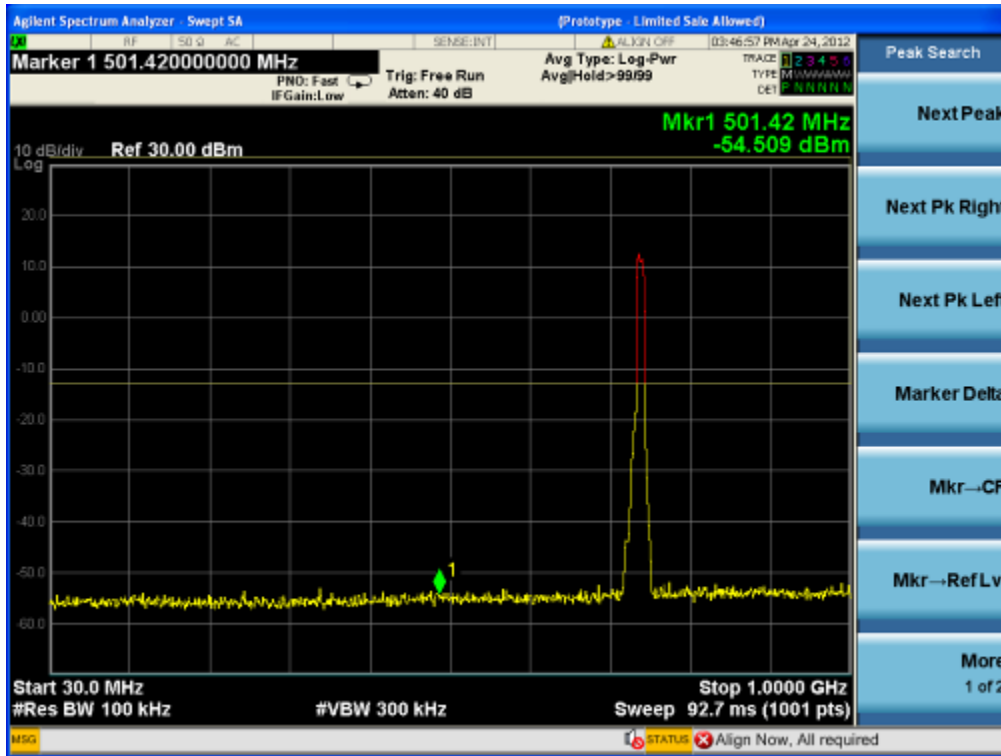

700MHz -LTE-16QAM downlink (highest frequency) Above 1GHz



700MHz -LTE-16QAM uplink (lowest frequency) 30MHz-1GHz

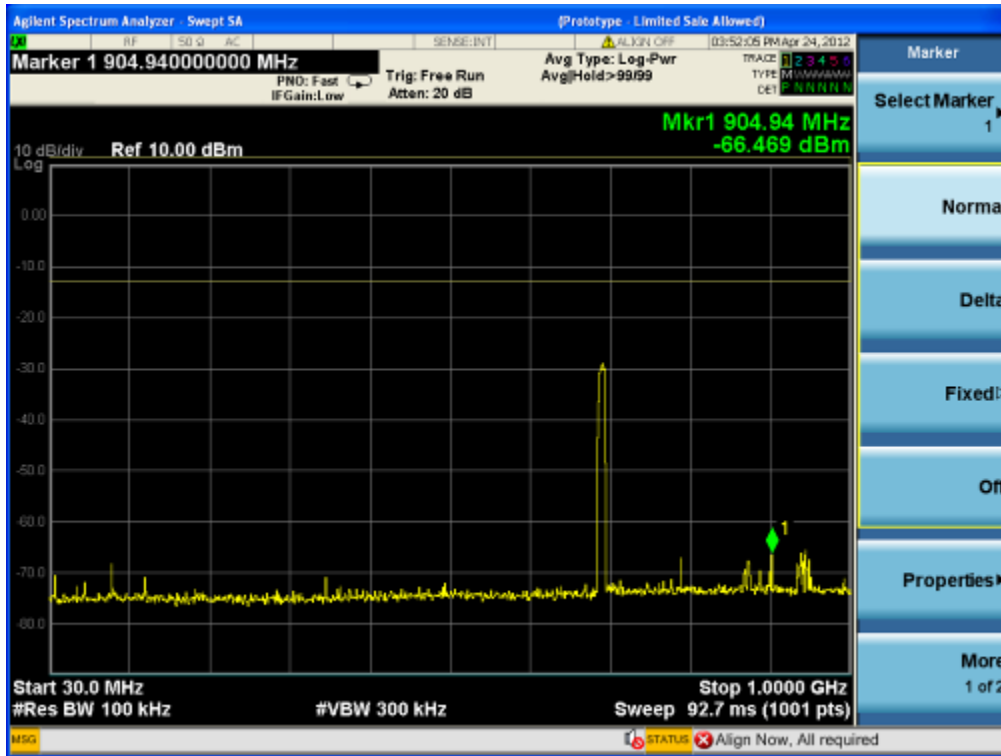

700MHz -LTE-16QAM uplink (lowest frequency) Above 1GHz

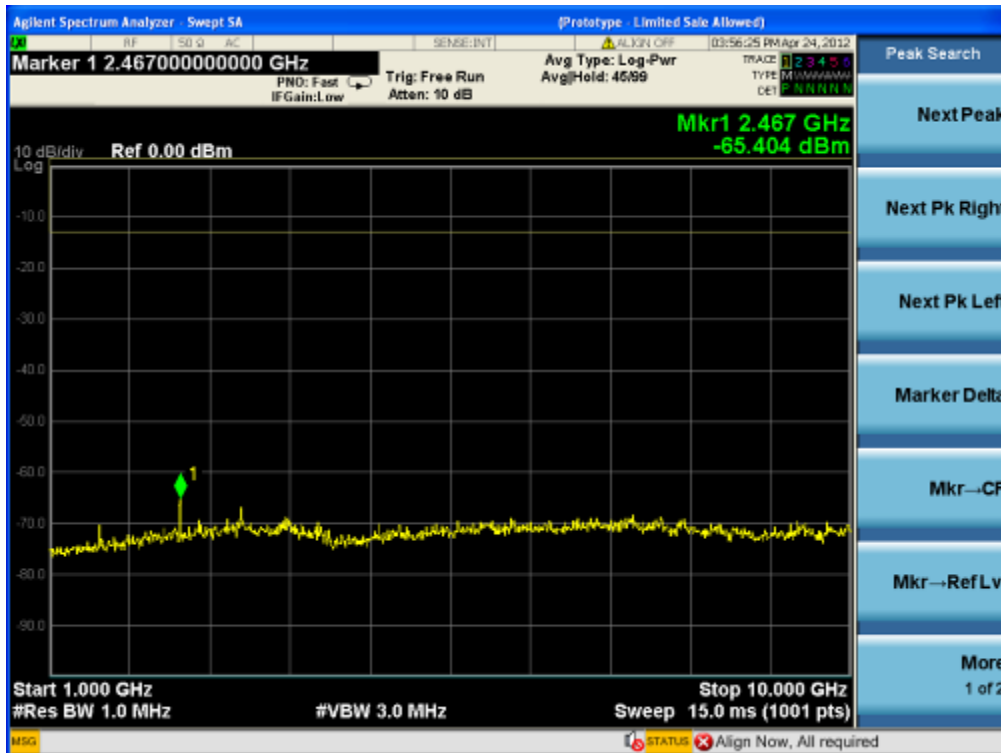

700MHz -LTE-16QAM uplink (middle frequency) 30MHz-1GHz

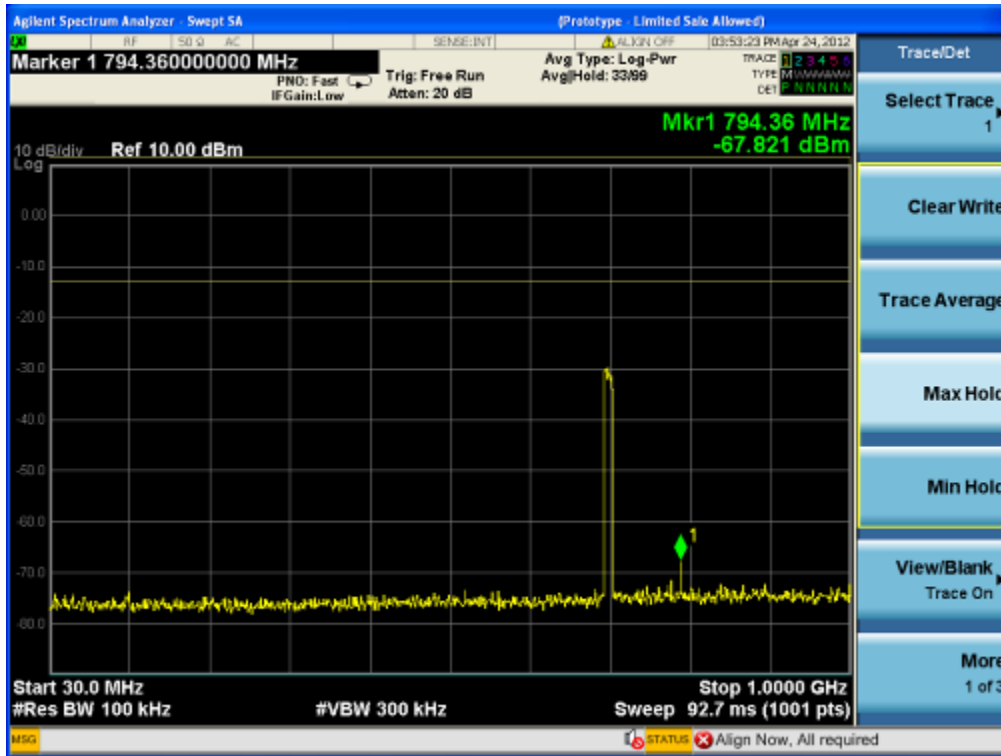

700MHz -LTE-16QAM uplink(middle frequency) Above 1GHz

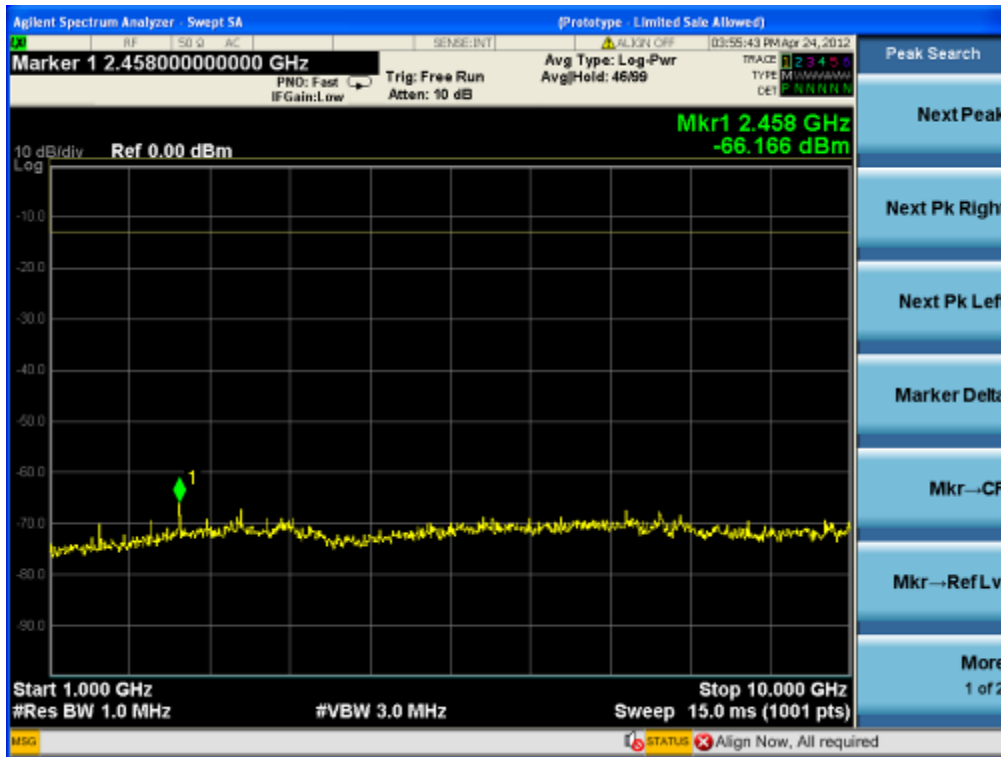

700MHz -LTE-16QAM uplink (highest frequency) 30MHz-1GHz

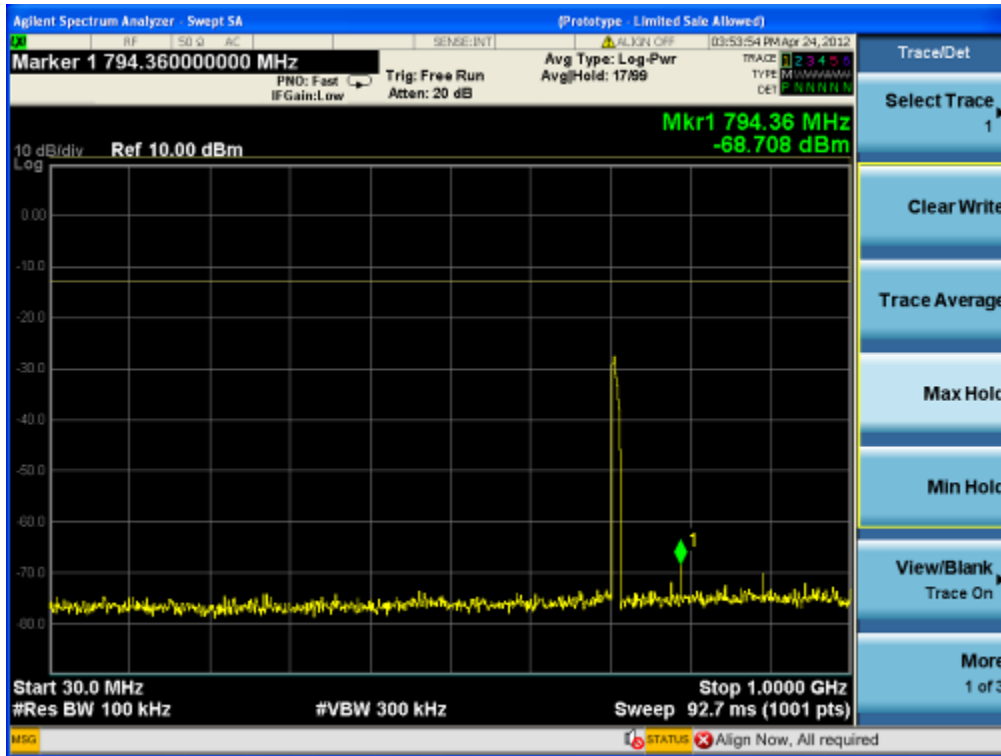

700MHz -LTE-16QAM uplink (highest frequency) Above 1GHz

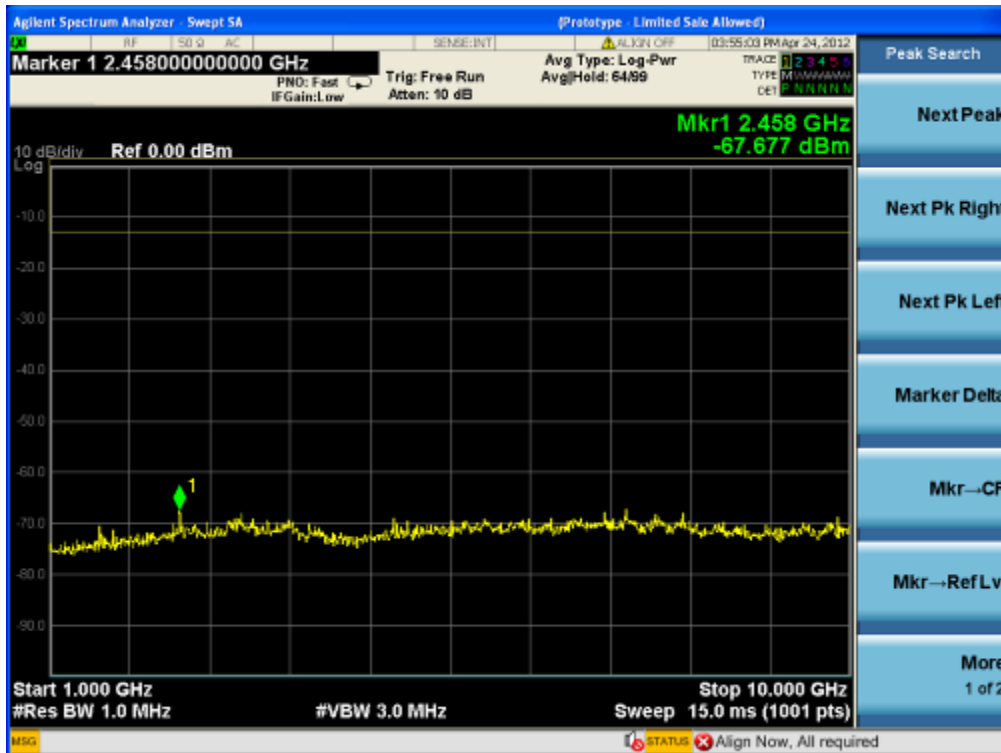

700MHz-LTE-64QAM downlink (lowest frequency) 30MHz-1GHz

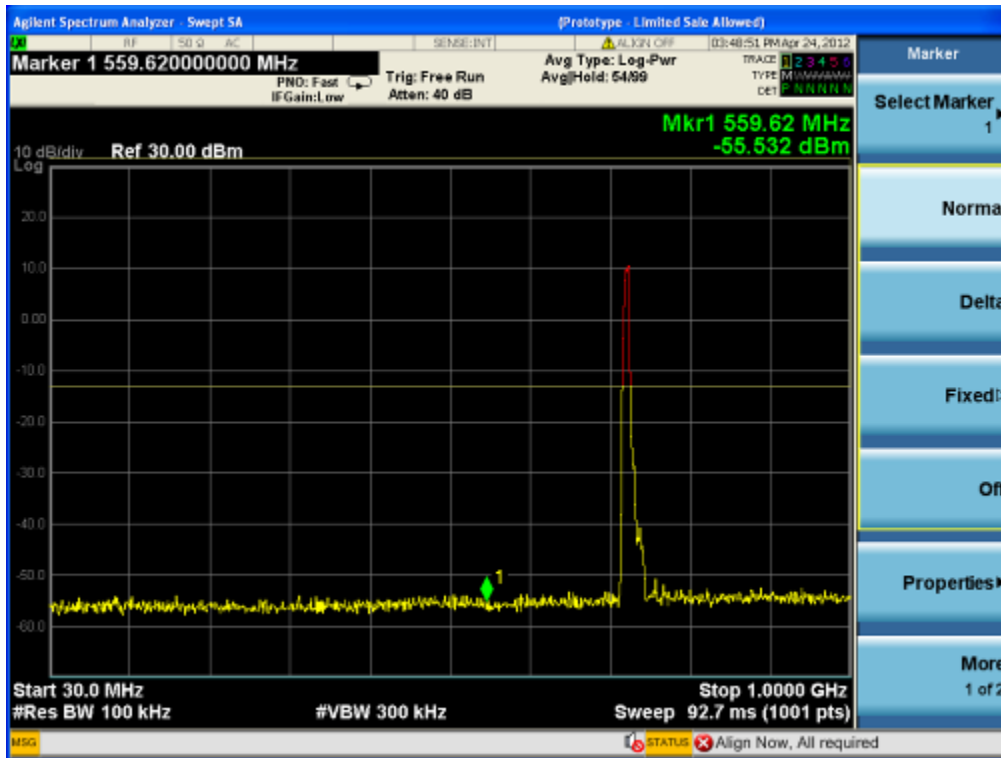

700MHz -LTE-64QAM downlink (lowest frequency) Above 1GHz

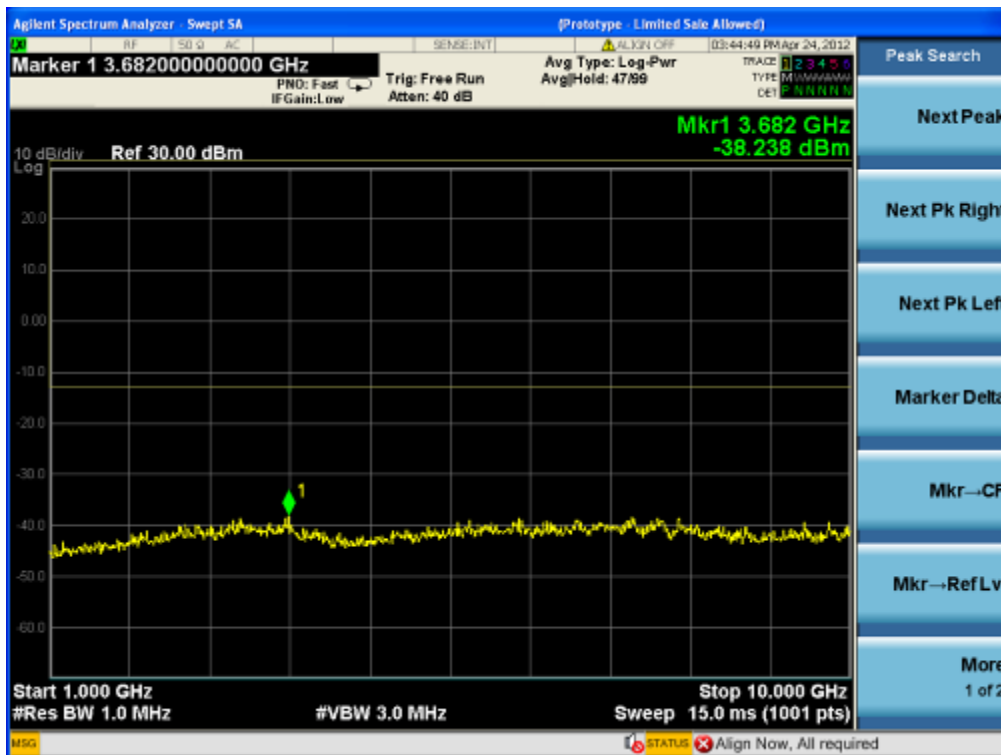

700MHz -LTE-64QAM downlink (middle frequency) 30MHz-1GHz

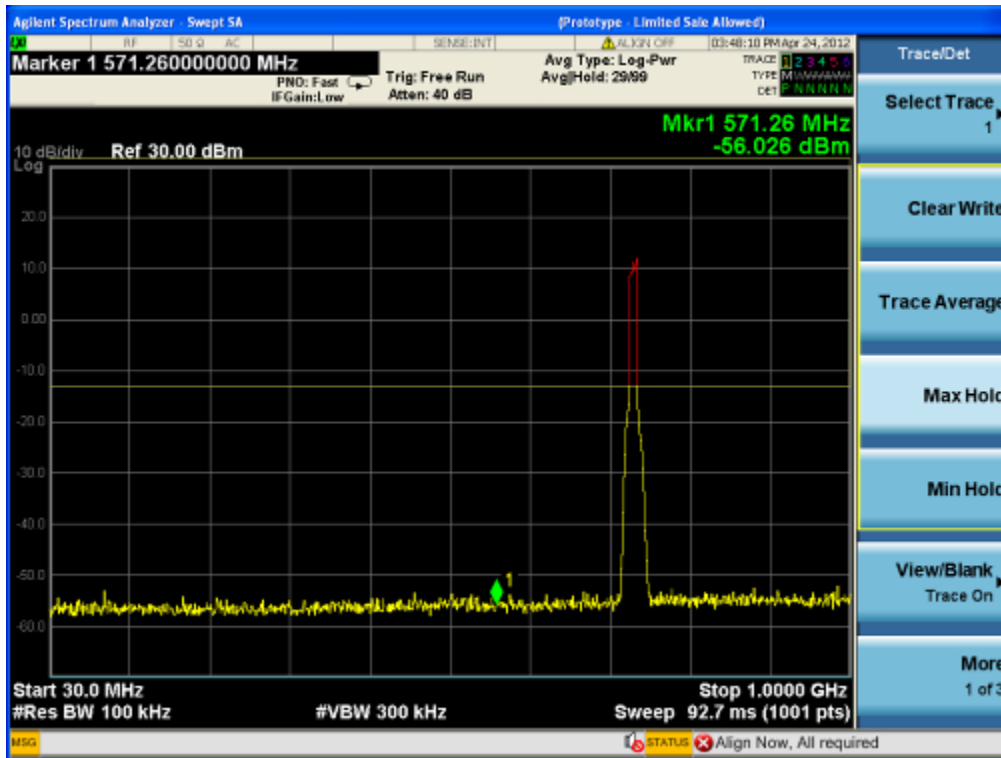

700MHz -LTE-64QAM downlink (middle frequency) Above 1GHz

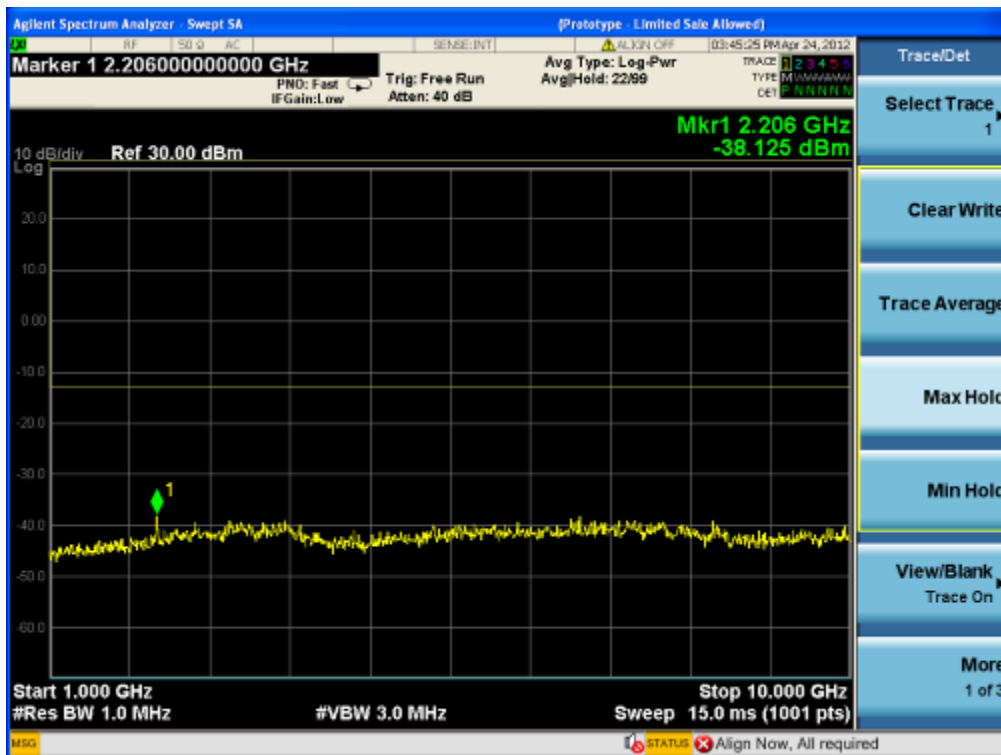

700MHz -LTE-64QAM downlink (highest frequency) 30MHz-1GHz

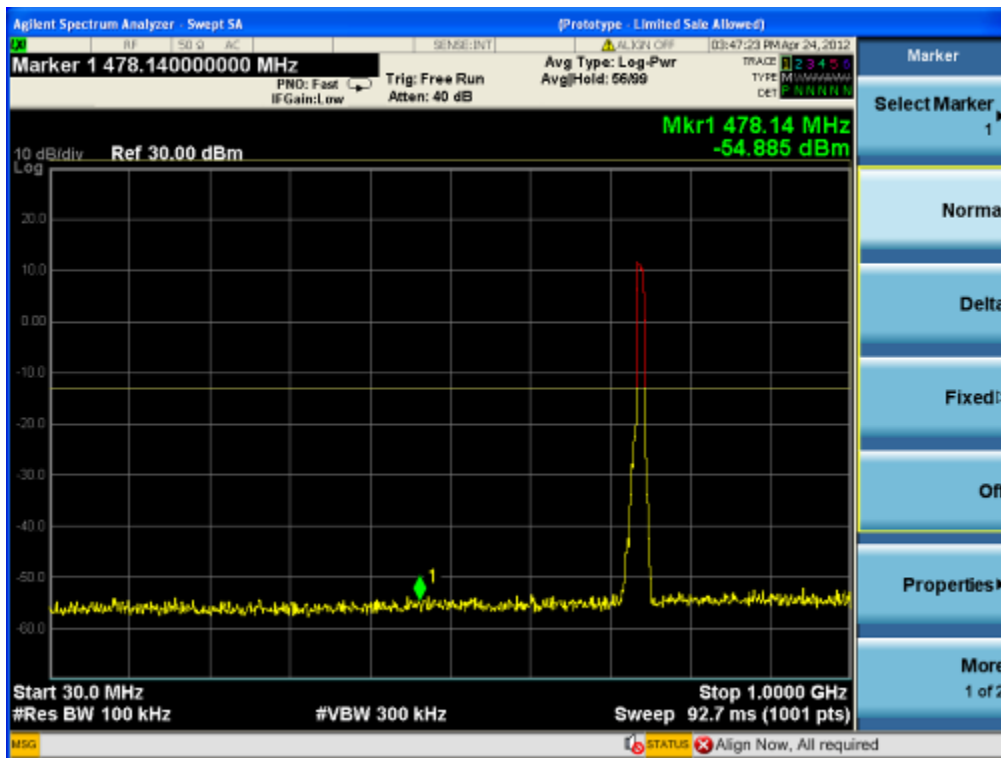

700MHz -LTE-64QAM downlink (highest frequency) Above 1GHz

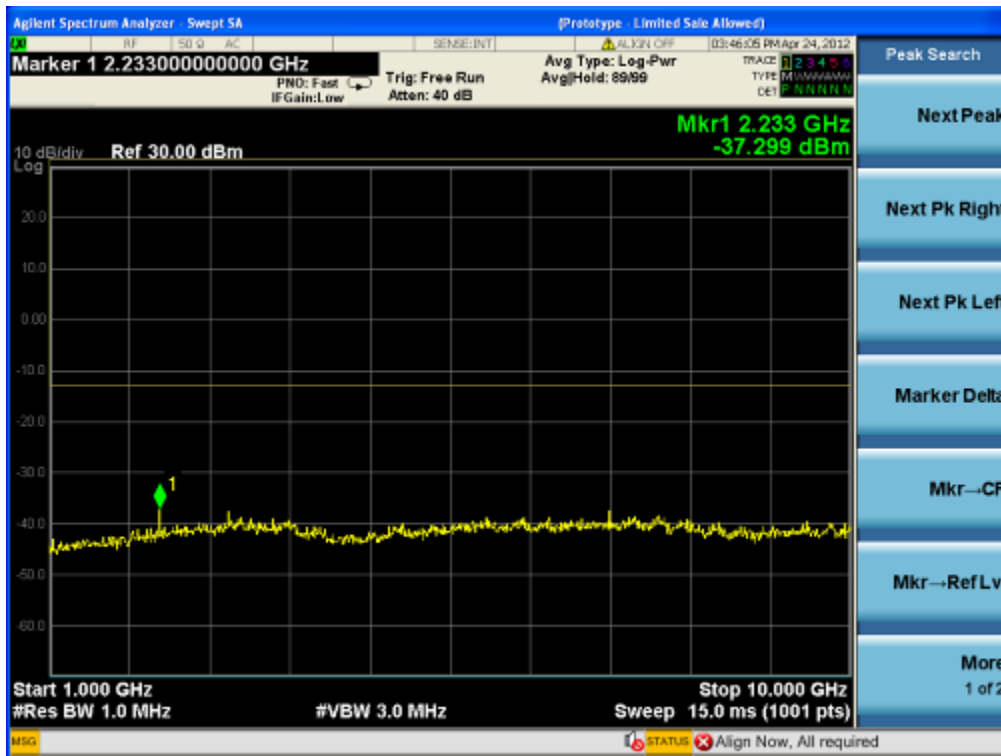

700MHz -LTE-64QAM uplink (lowest frequency) 30MHz-1GHz

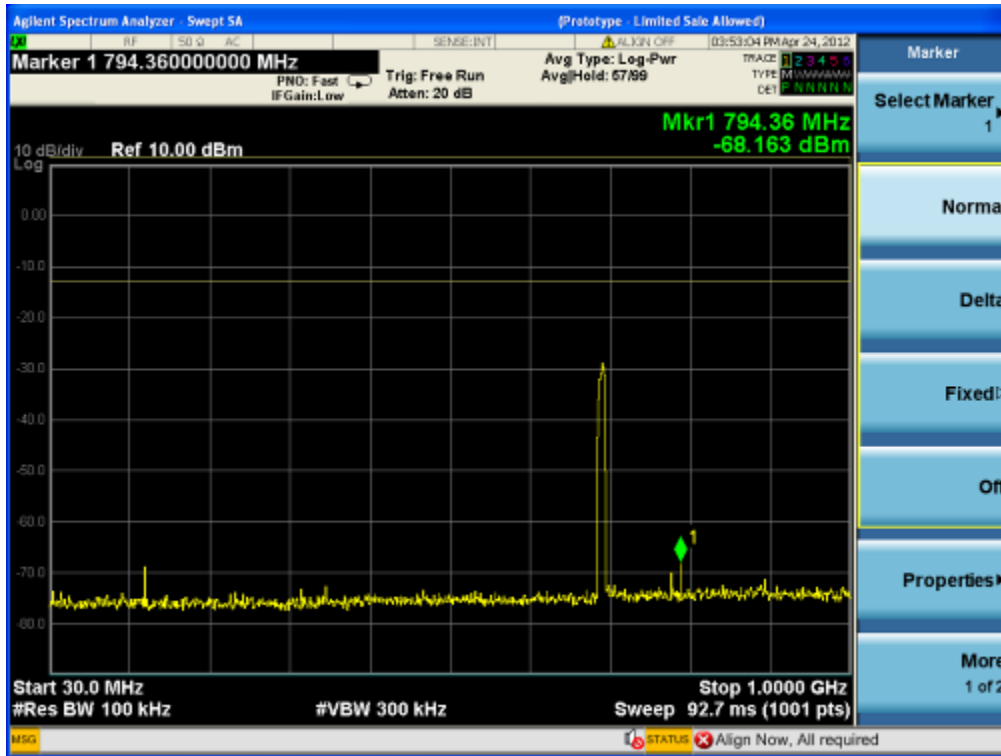

700MHz -LTE-64QAM uplink (lowest frequency) Above 1GHz

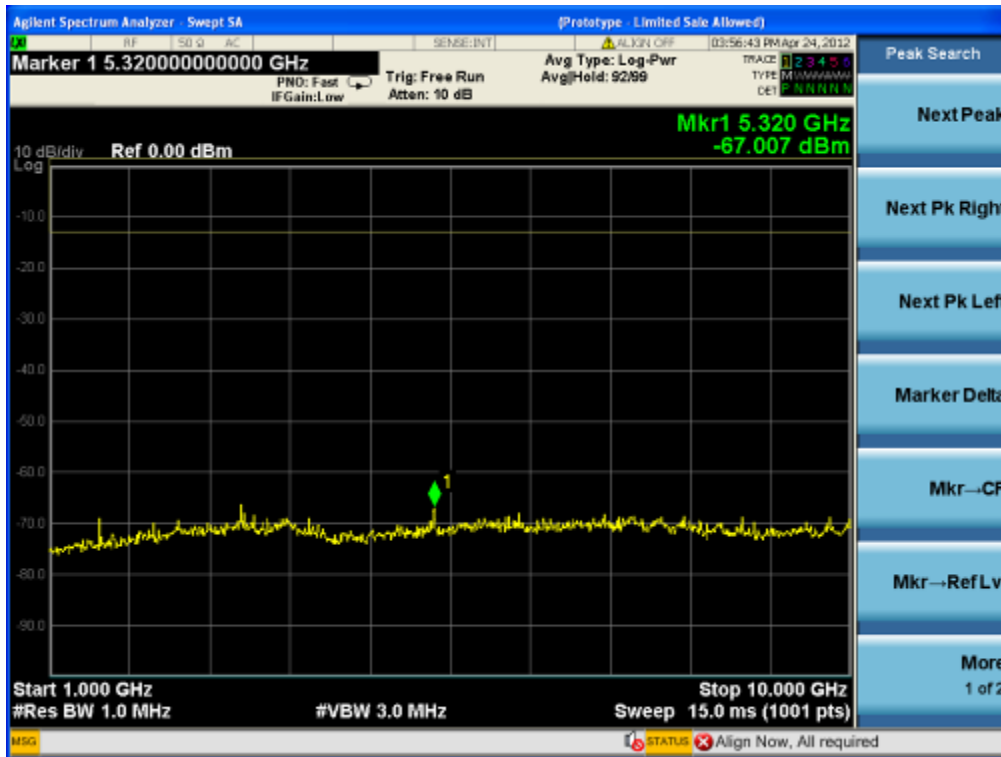

700MHz -LTE-64QAM uplink (middle frequency) 30MHz-1GHz

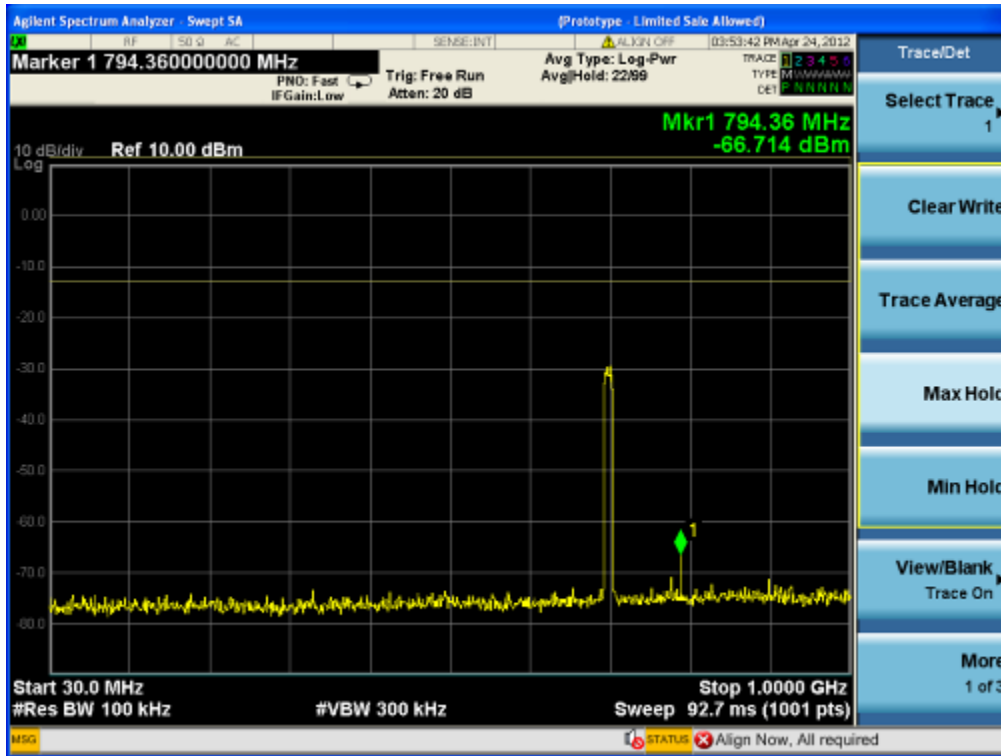

700MHz -LTE-64QAM uplink(middle frequency) Above 1GHz

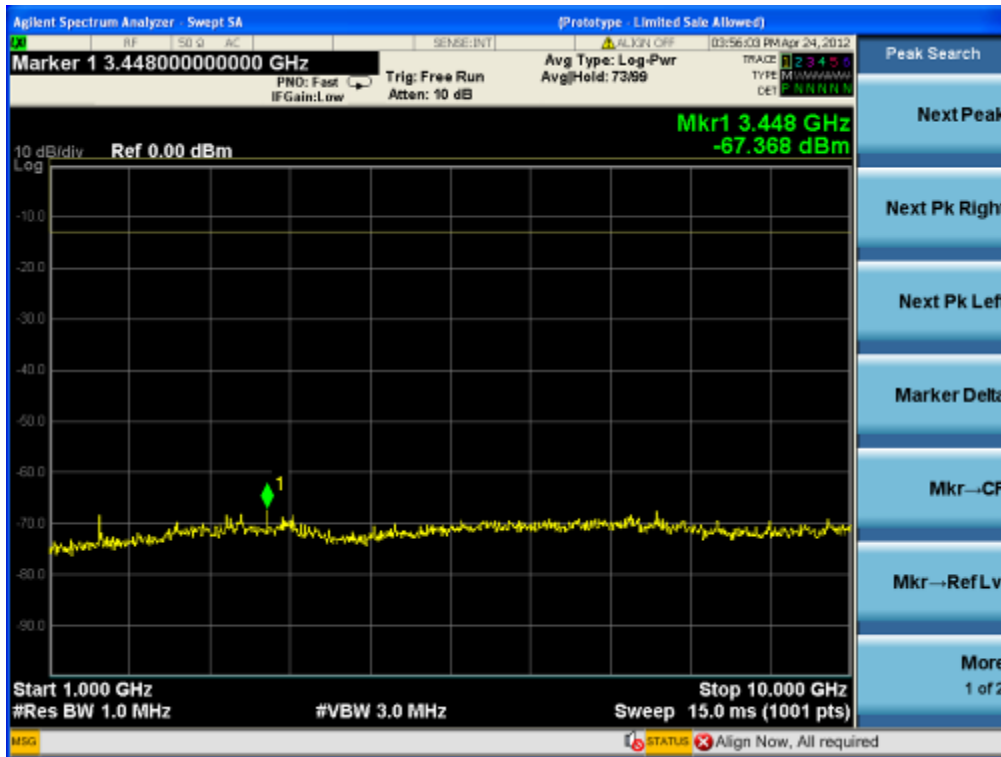

700MHz -LTE-64QAM uplink (highest frequency) 30MHz-1GHz

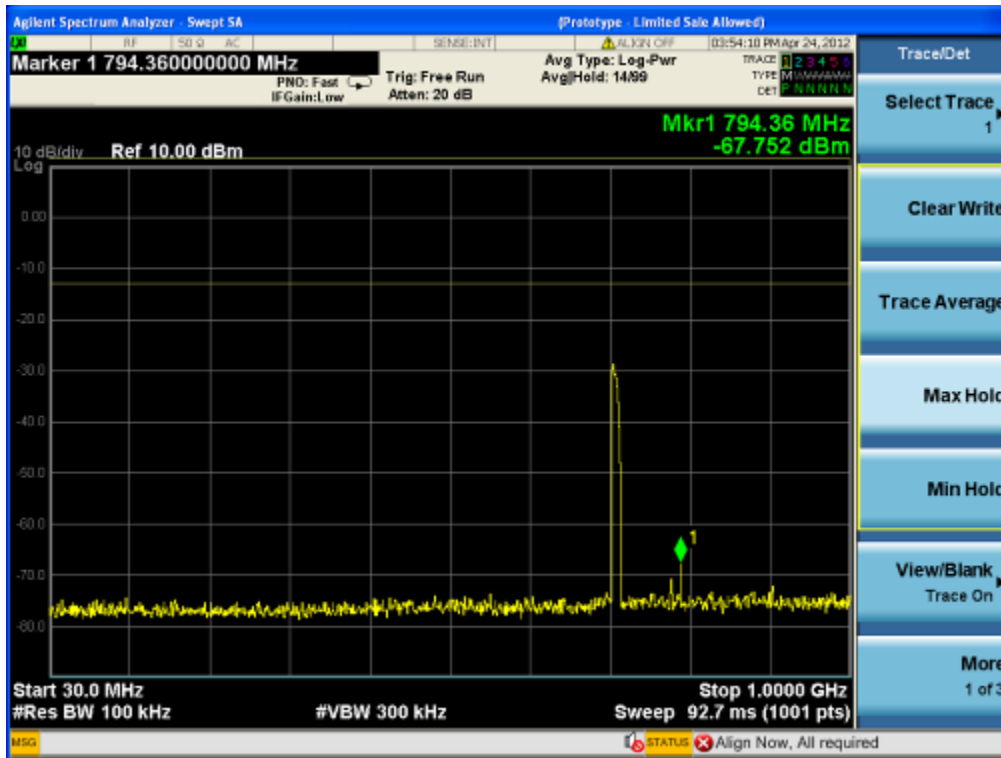

700MHz -LTE-64QAM uplink (highest frequency) Above 1GHz



Cellular Band

Cellular-GSM downlink (lowest frequency) 30MHz-1GHz

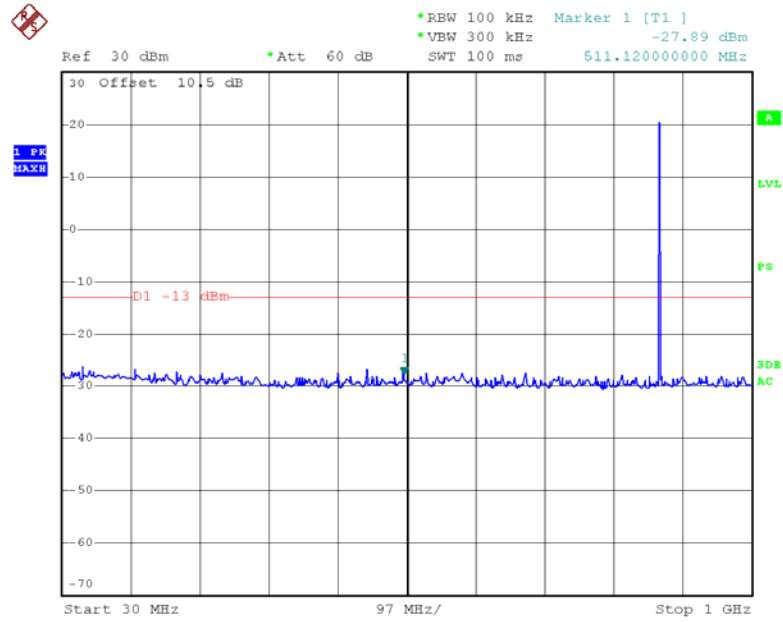

Cellular-GSM downlink (lowest frequency) Above 1GHz

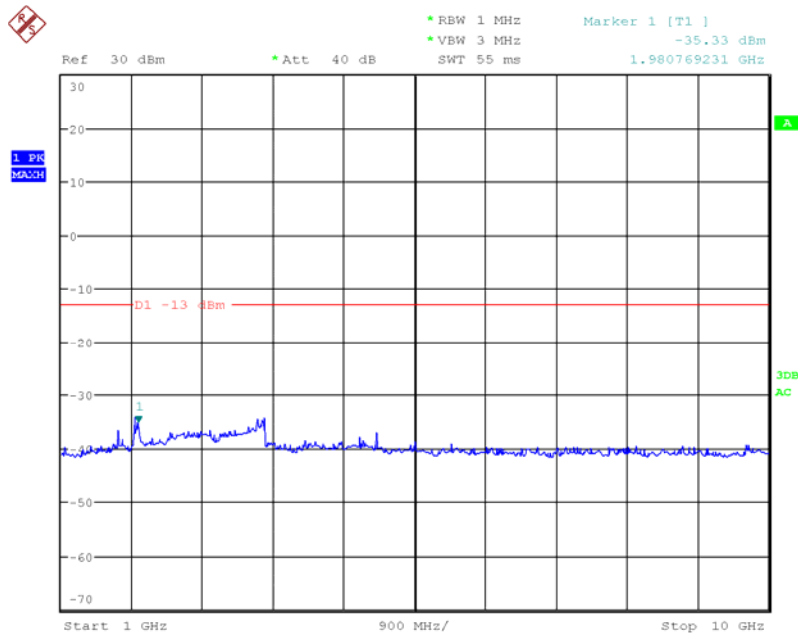

Cellular-GSM downlink (middle frequency) 30MHz-1GHz

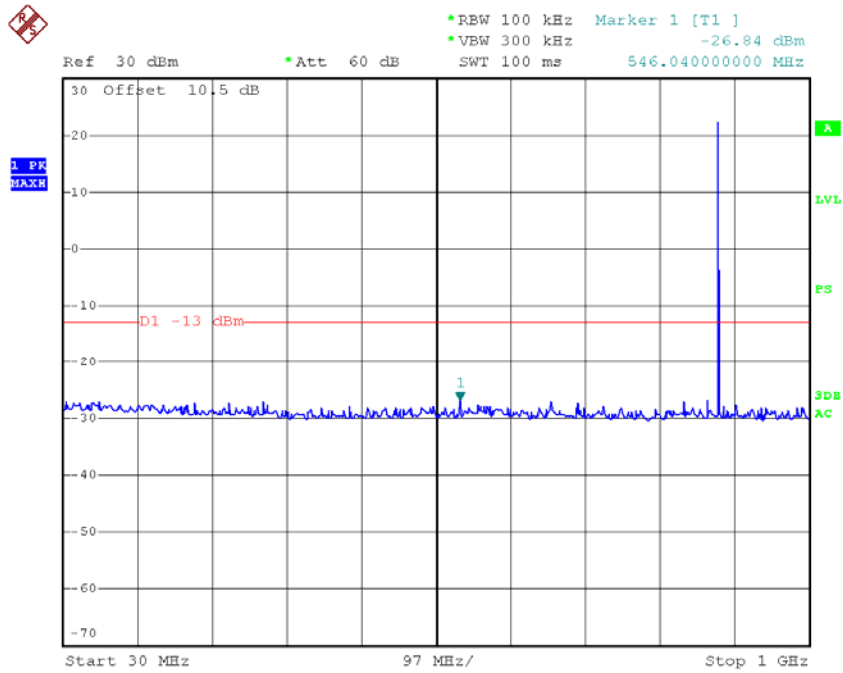

Cellular-GSM downlink (middle frequency) Above 1GHz

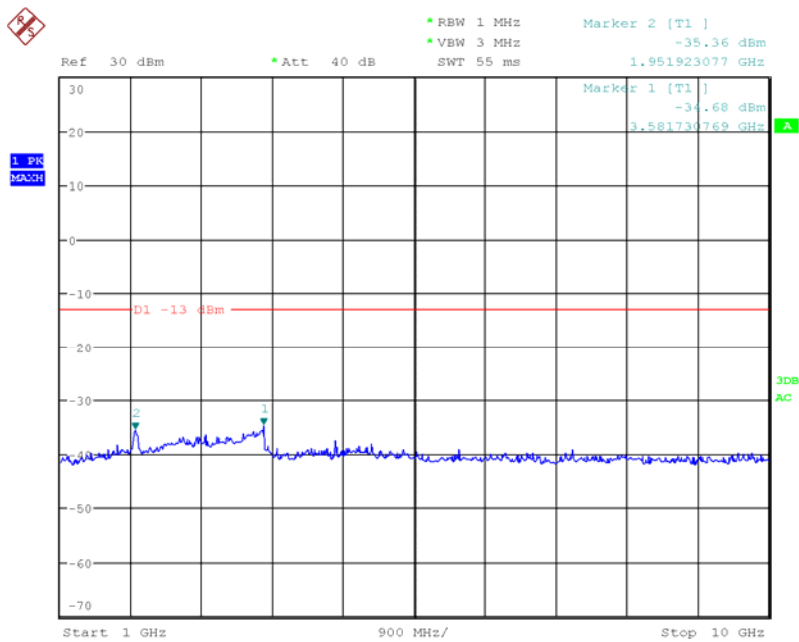

Cellular-GSM downlink (highest frequency) 30MHz-1GHz

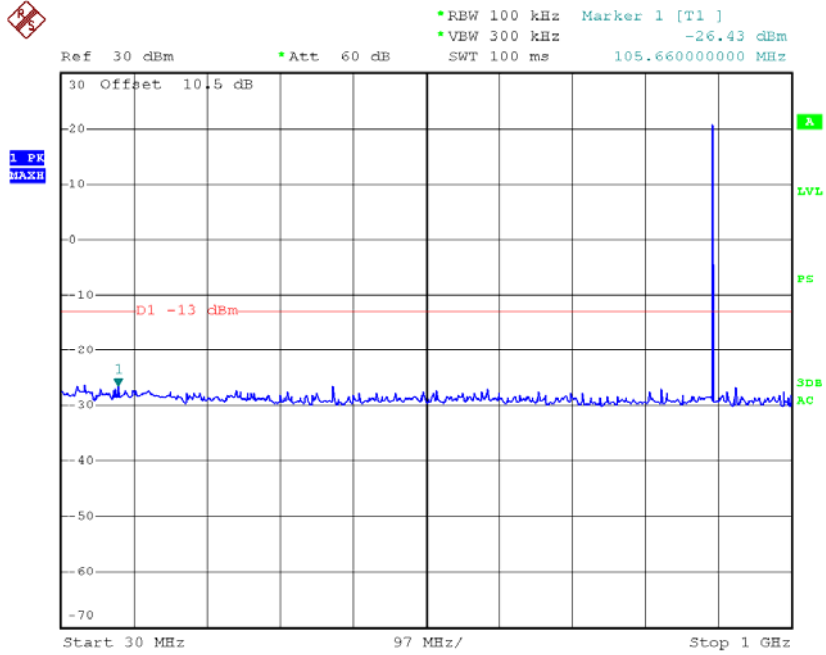

Cellular-GSM downlink (highest frequency) Above 1GHz

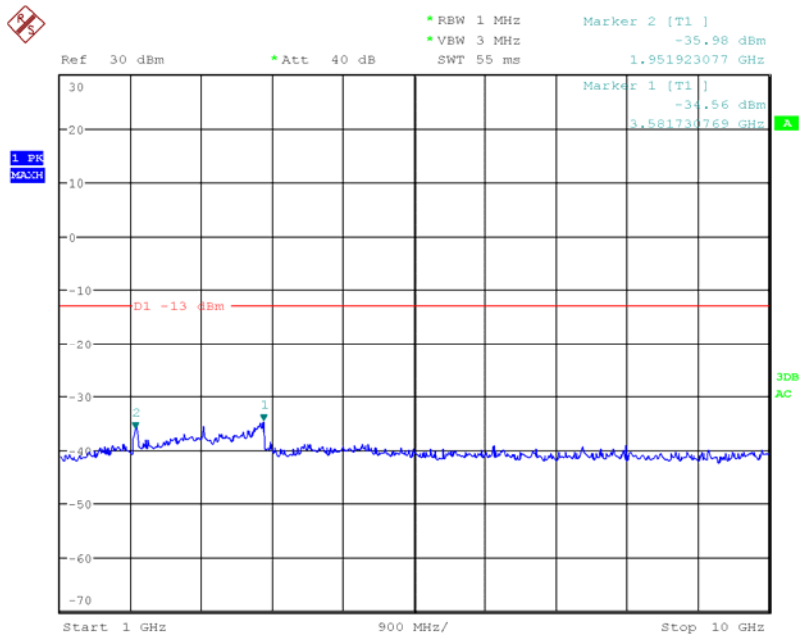

Cellular-GSM uplink (lowest frequency) 30MHz-1GHz

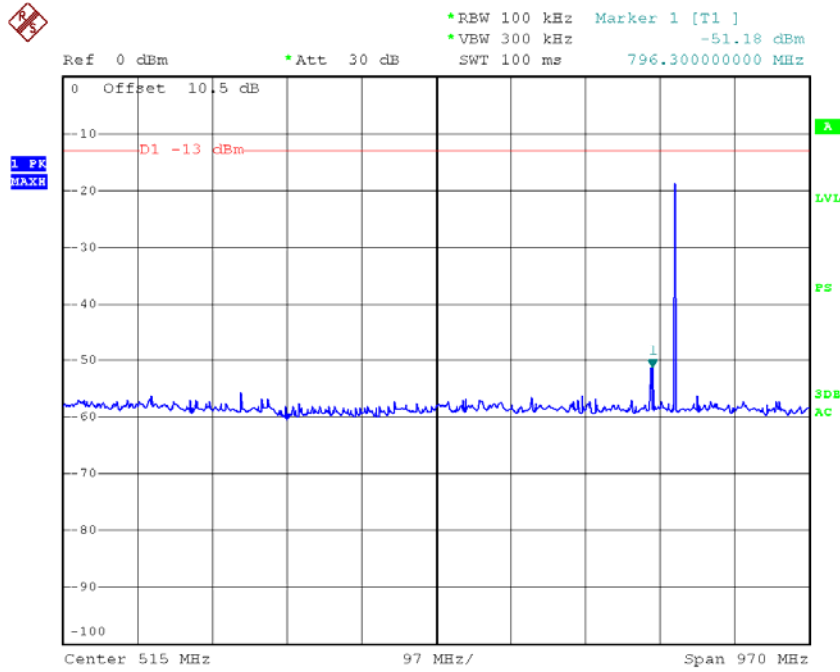

Cellular-GSM uplink (lowest frequency) Above 1GHz

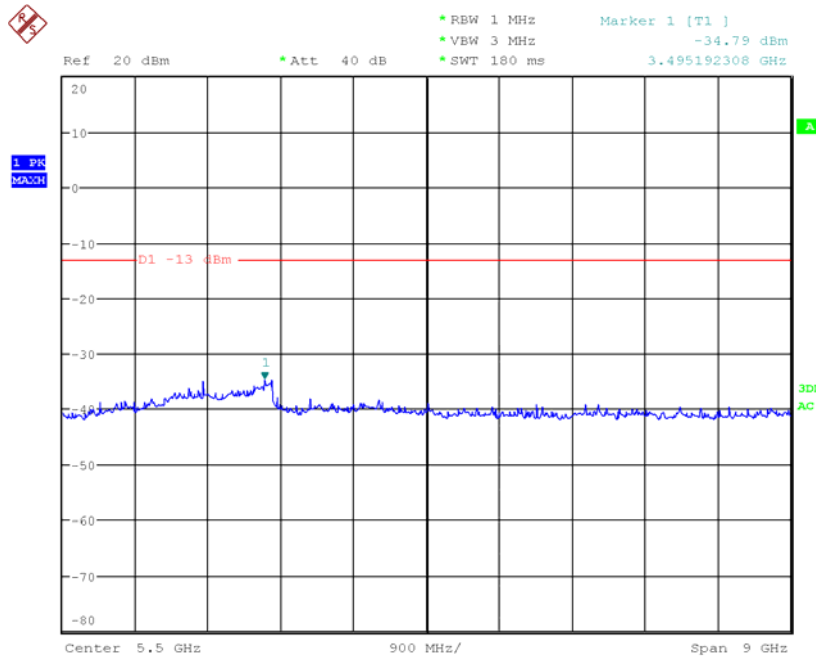

Cellular-GSM uplink (middle frequency) 30MHz-1GHz

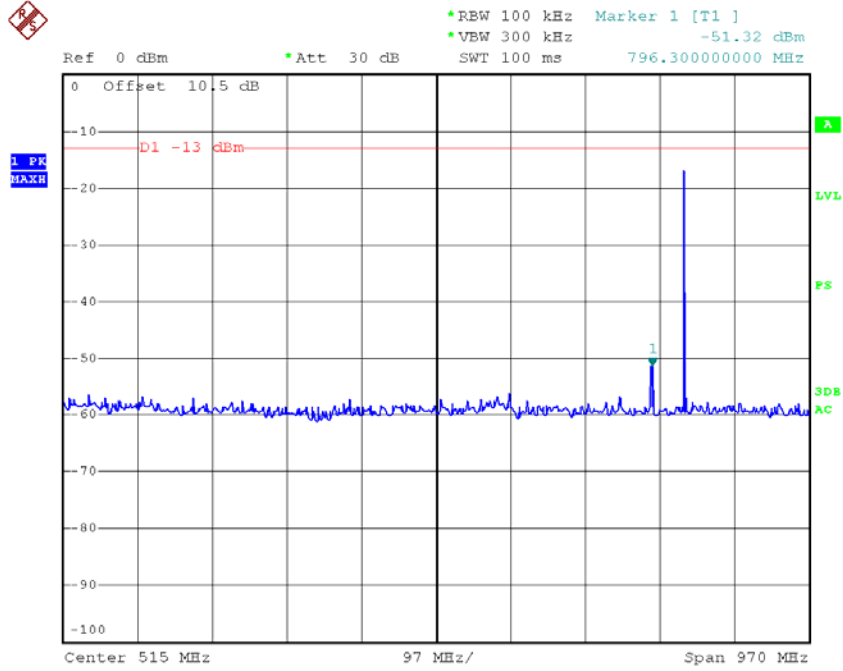

Cellular-GSM uplink(middle frequency) Above 1GHz

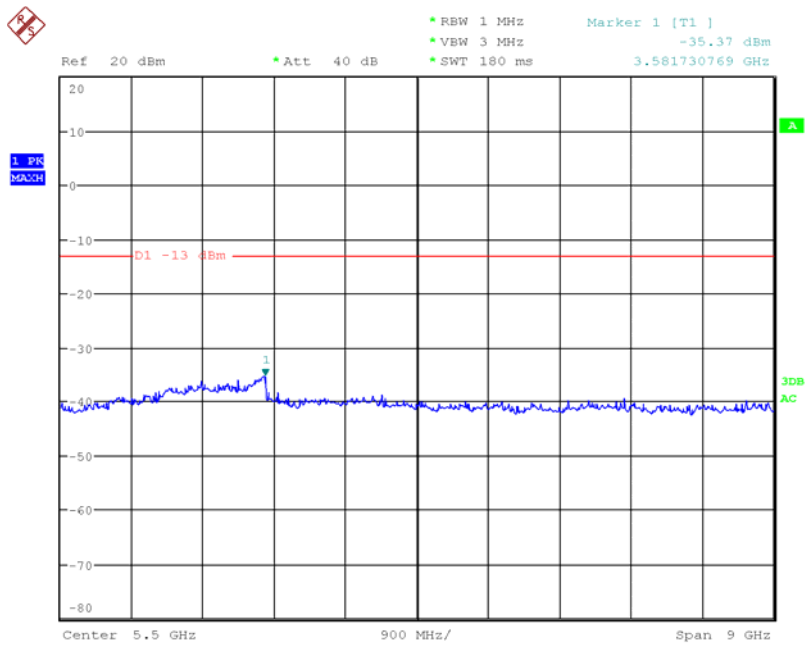

Cellular-GSM uplink (highest frequency) 30MHz-1GHz

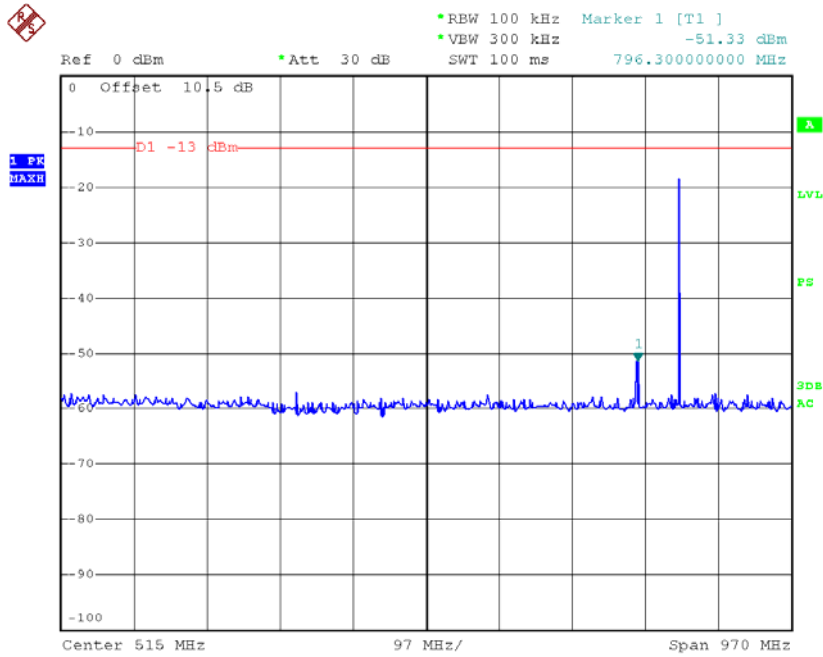

Cellular-GSM uplink (highest frequency) Above 1GHz

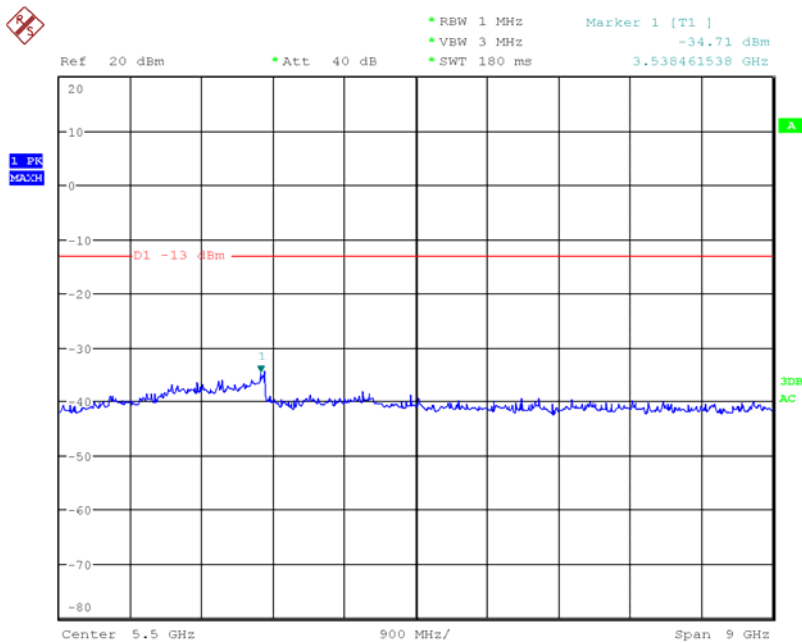

Cellular-EDGE downlink (lowest frequency) 30MHz-1GHz

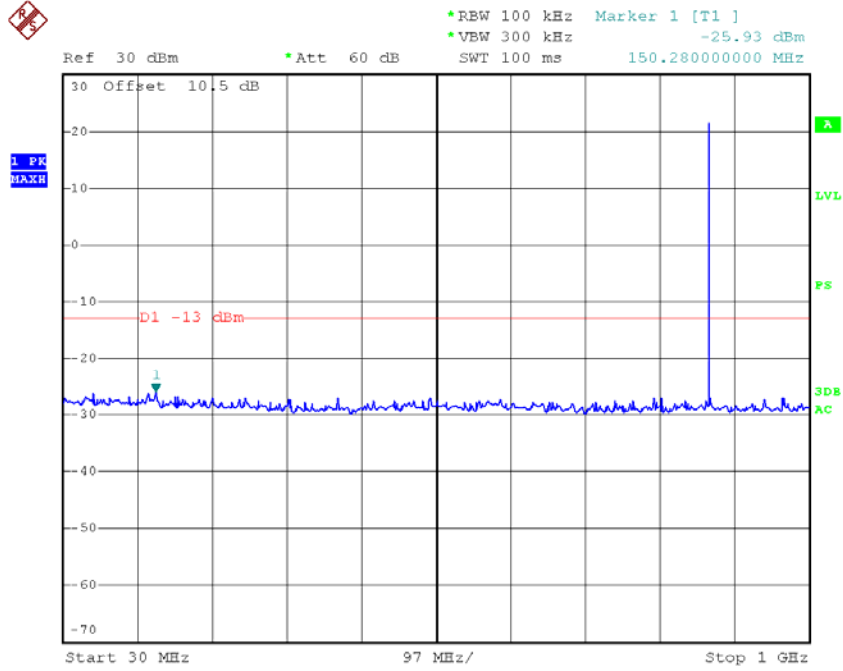

Cellular-EDGE downlink (lowest frequency) Above 1GHz

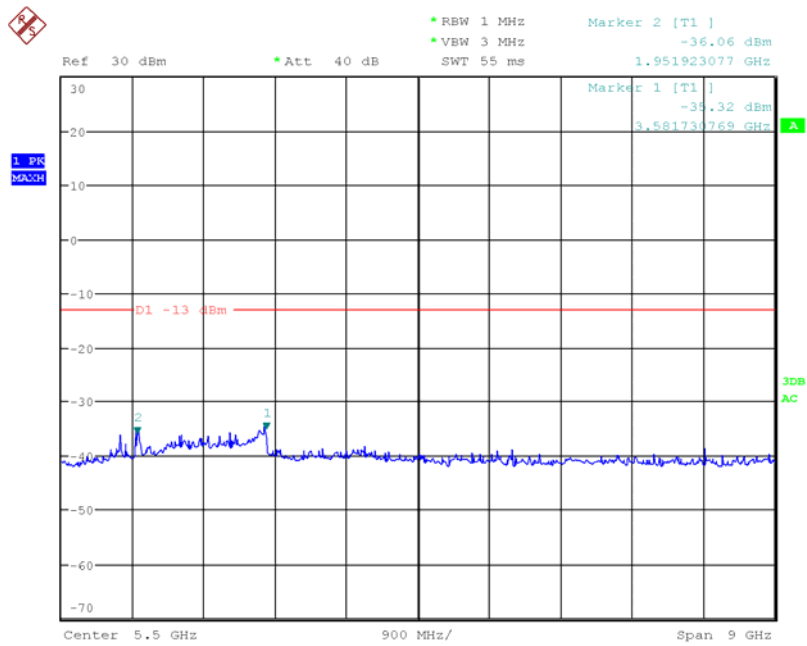

Cellular-EDGE downlink (middle frequency) 30MHz-1GHz

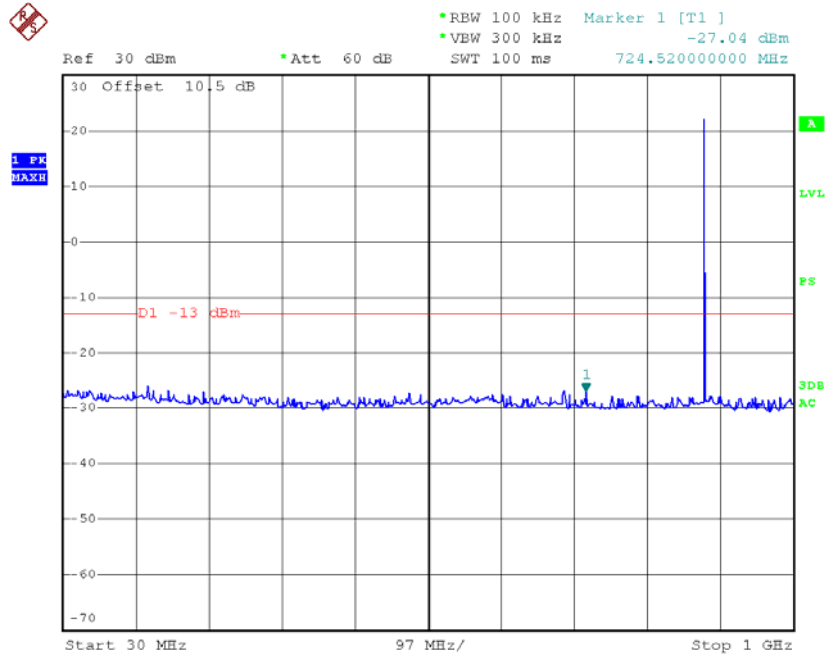

Cellular-EDGE downlink (middle frequency) Above 1GHz

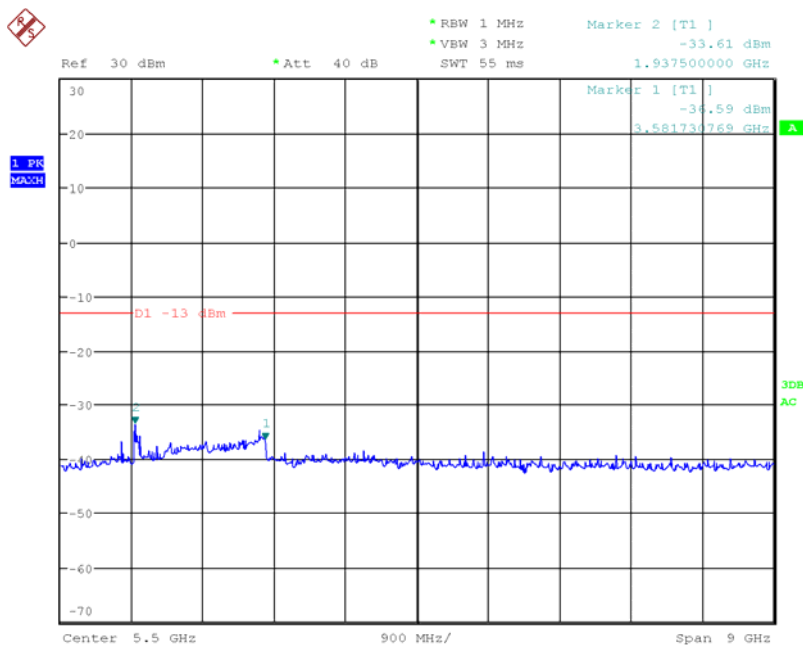

Cellular-EDGE downlink (highest frequency) 30MHz-1GHz

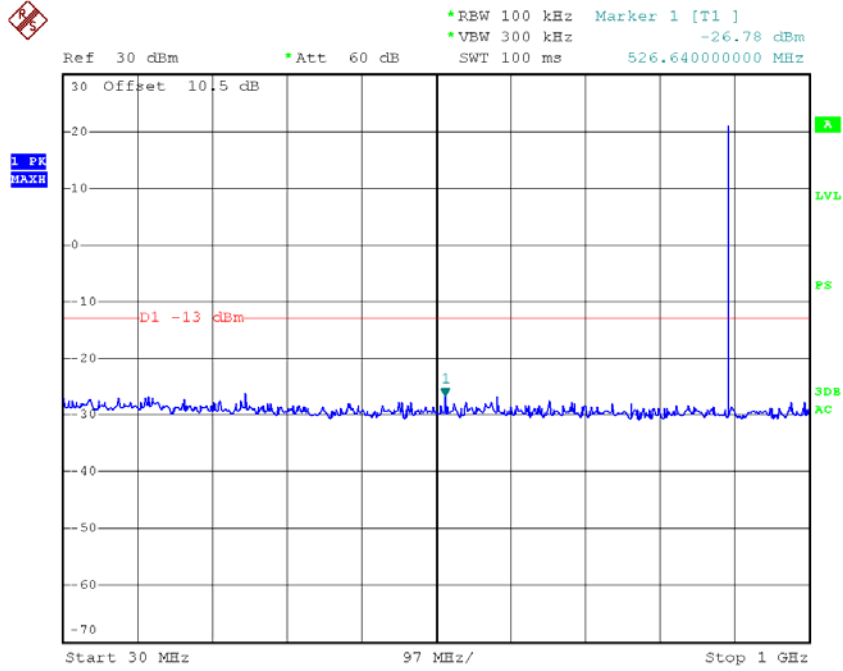

Cellular-EDGE downlink (highest frequency) Above 1GHz

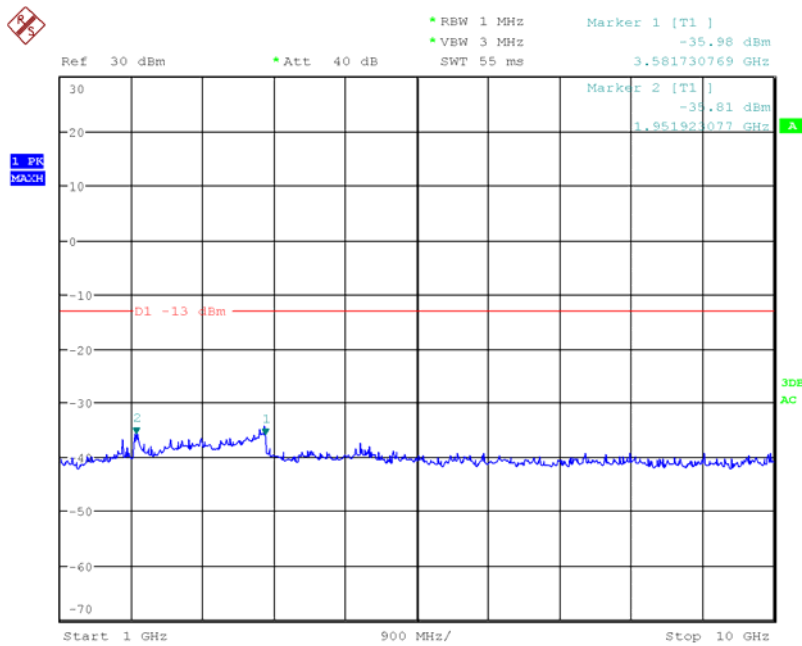

Cellular-EDGE uplink (lowest frequency) 30MHz-1GHz

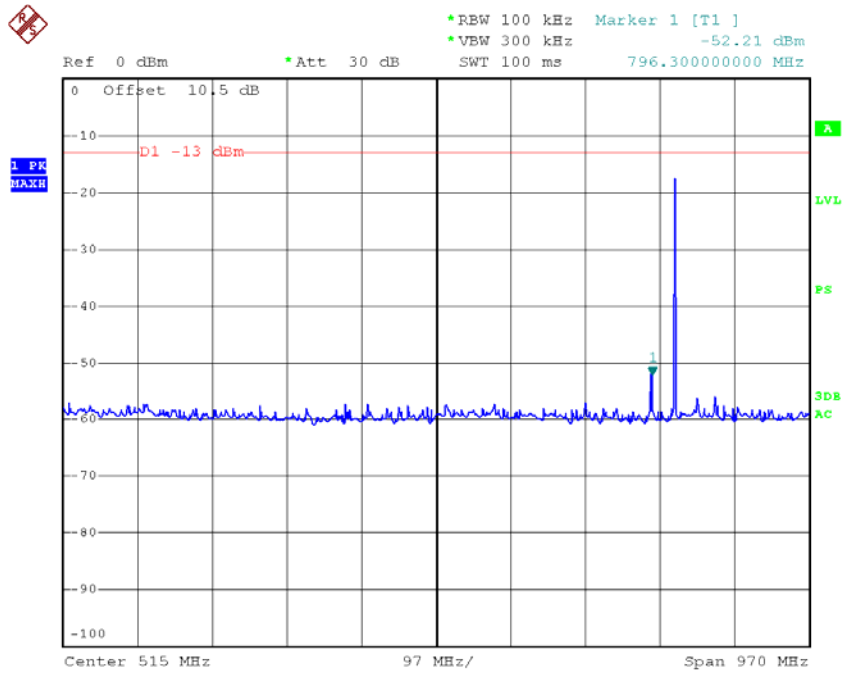

Cellular-EDGE uplink (lowest frequency) Above 1GHz

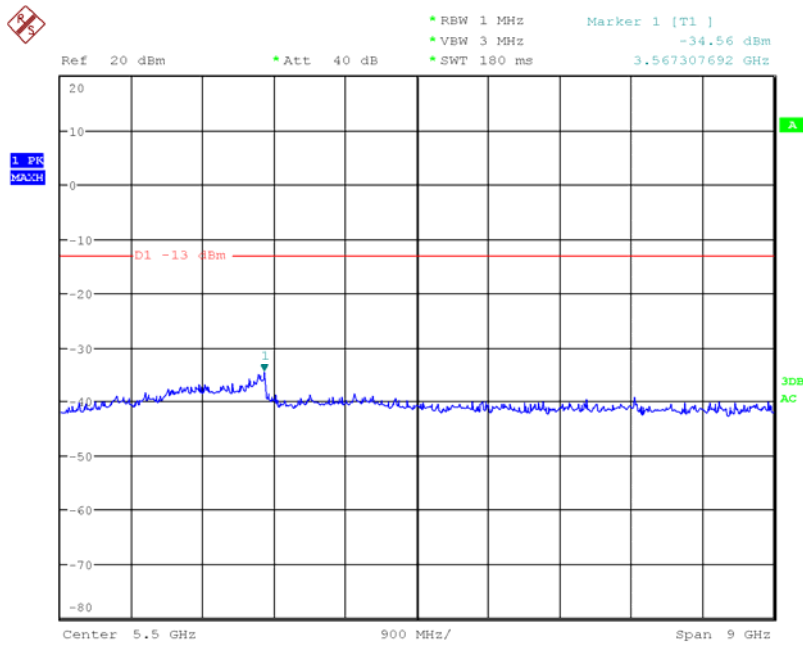

Cellular-EDGE uplink (middle frequency) 30MHz-1GHz

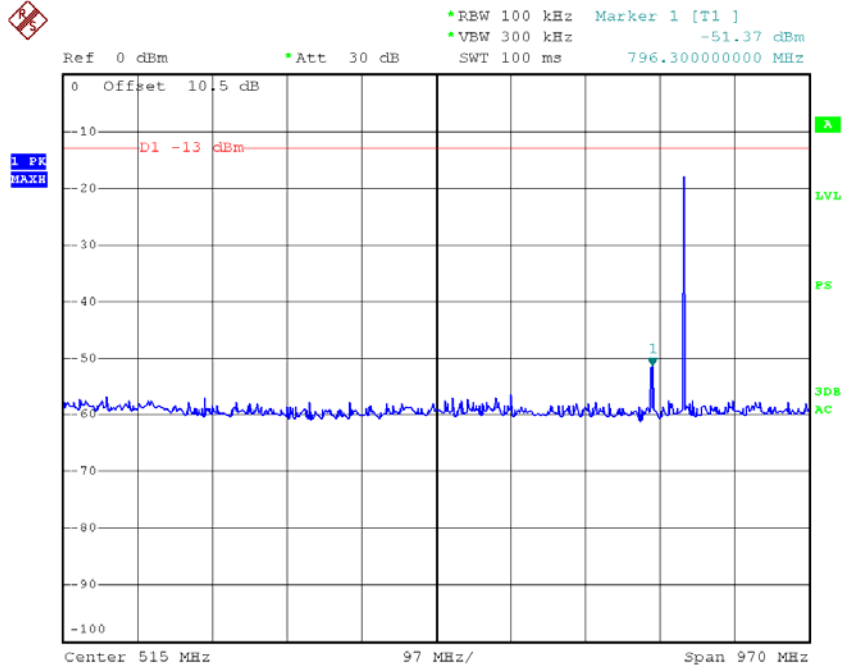

Cellular-EDGE uplink(middle frequency) Above 1GHz

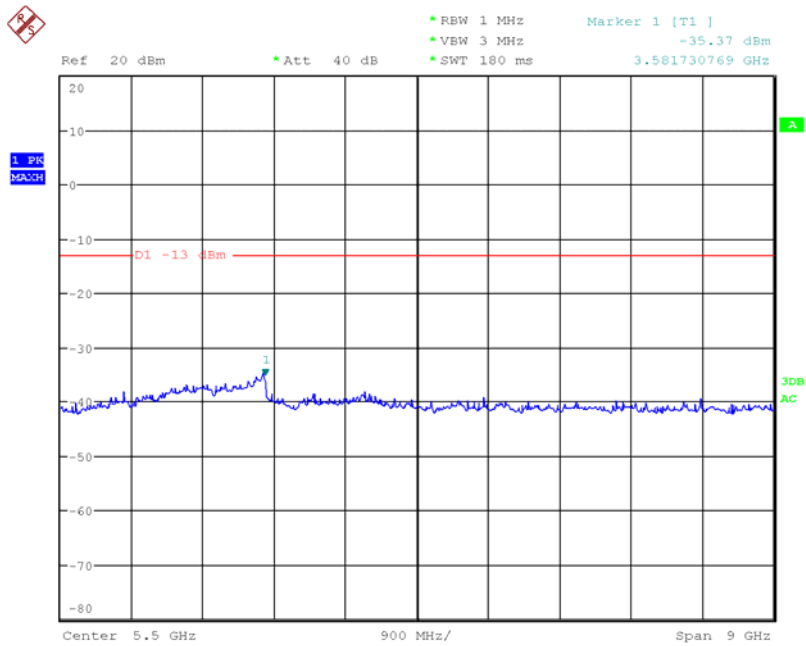

Cellular-EDGE uplink (highest frequency) 30MHz-1GHz

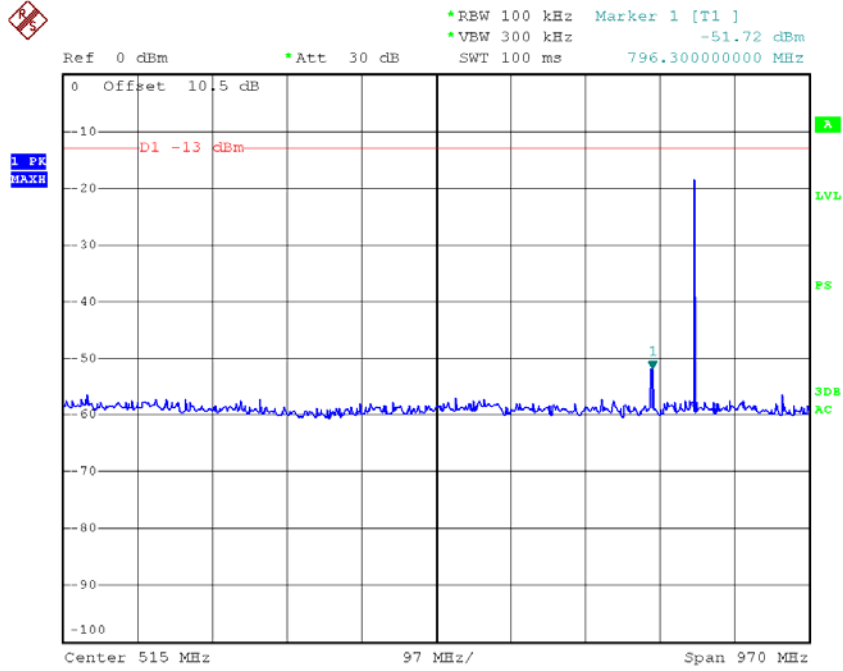

Cellular-EDGE uplink (highest frequency) Above 1GHz

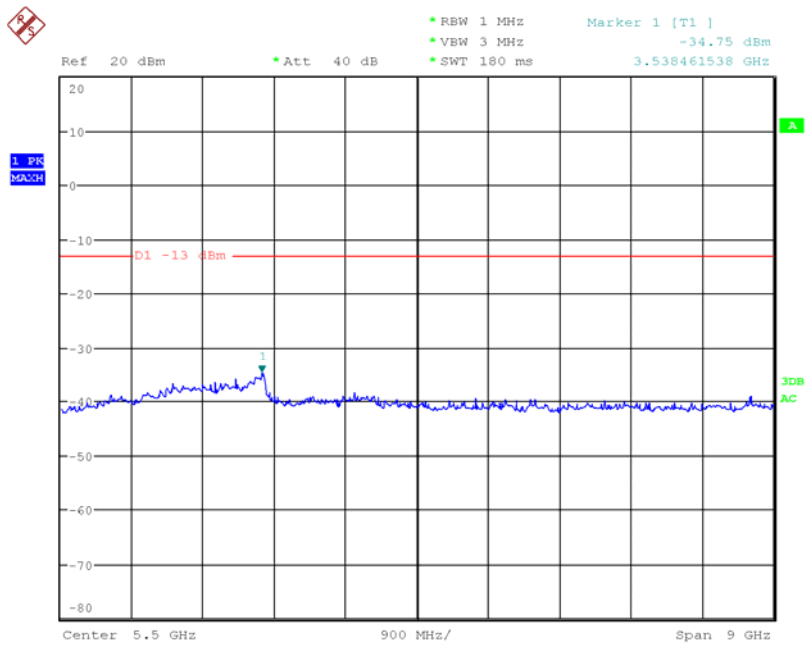

Cellular-CDMA2000 downlink (lowest frequency) 30MHz-1GHz

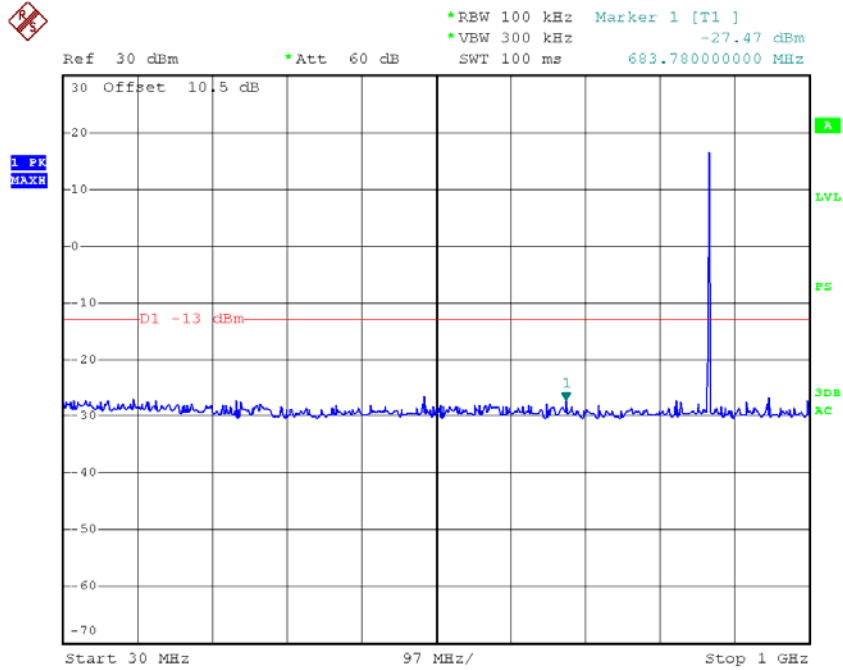

Cellular-CDMA2000 downlink (lowest frequency) Above 1GHz

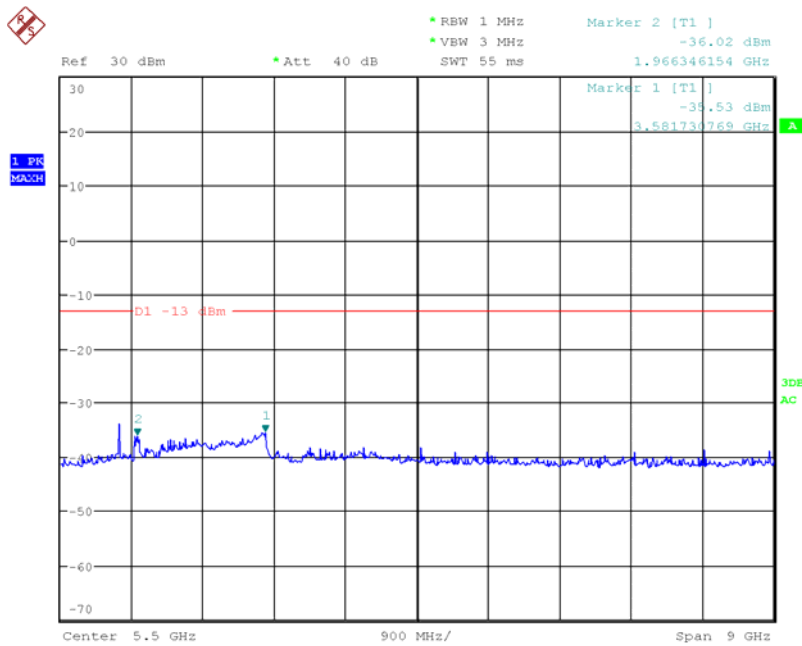

Cellular-CDMA2000 downlink (middle frequency) 30MHz-1GHz

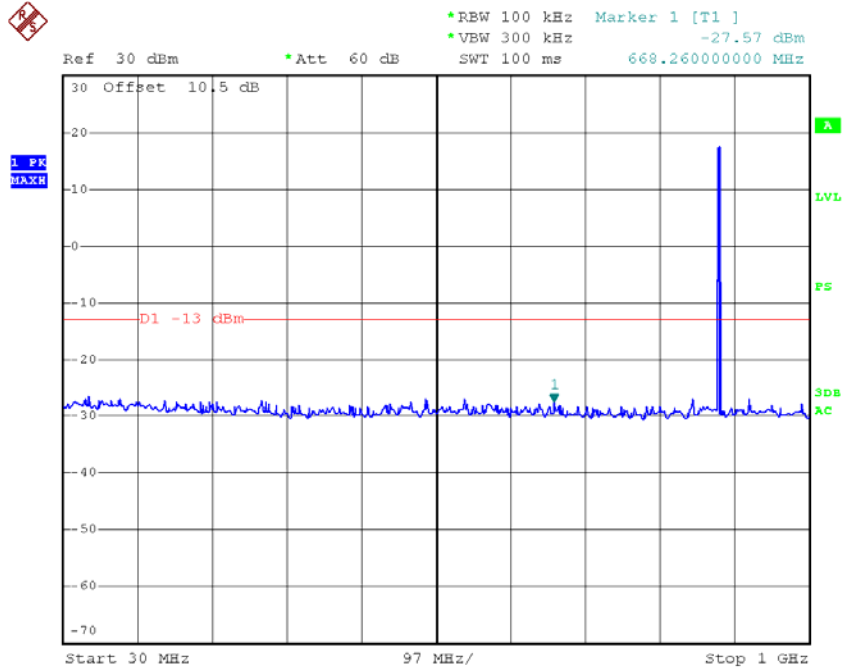

Cellular-CDMA2000 downlink (middle frequency) Above 1GHz

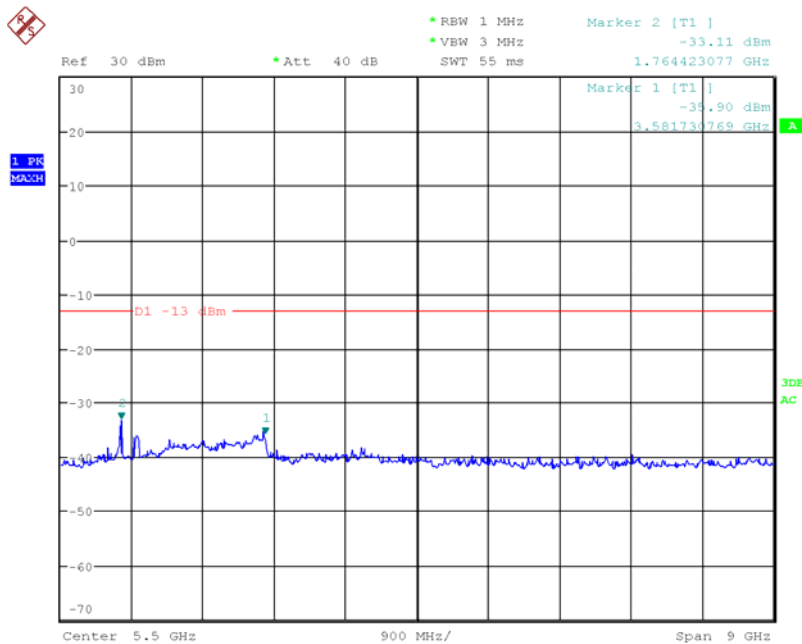

Cellular-CDMA2000 downlink (highest frequency) 30MHz-1GHz

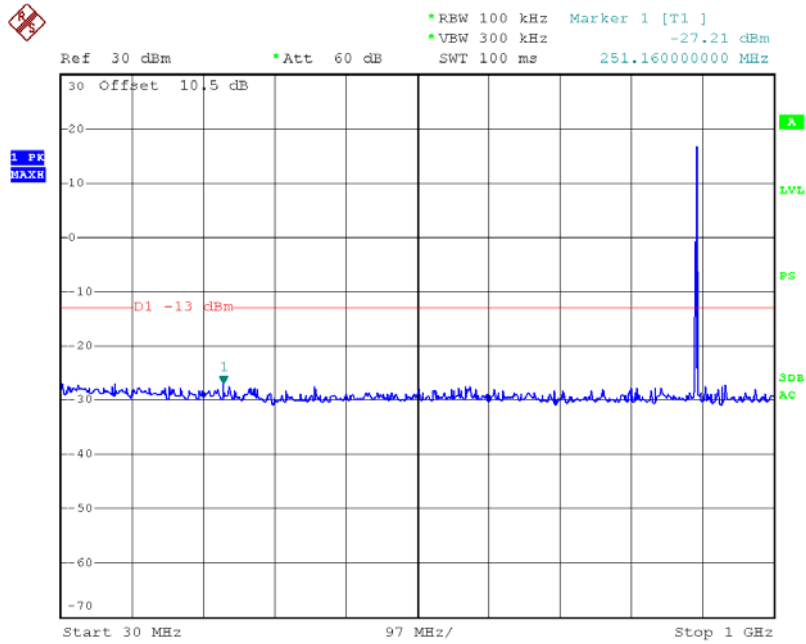

Cellular-CDMA2000 downlink (highest frequency) Above 1GHz

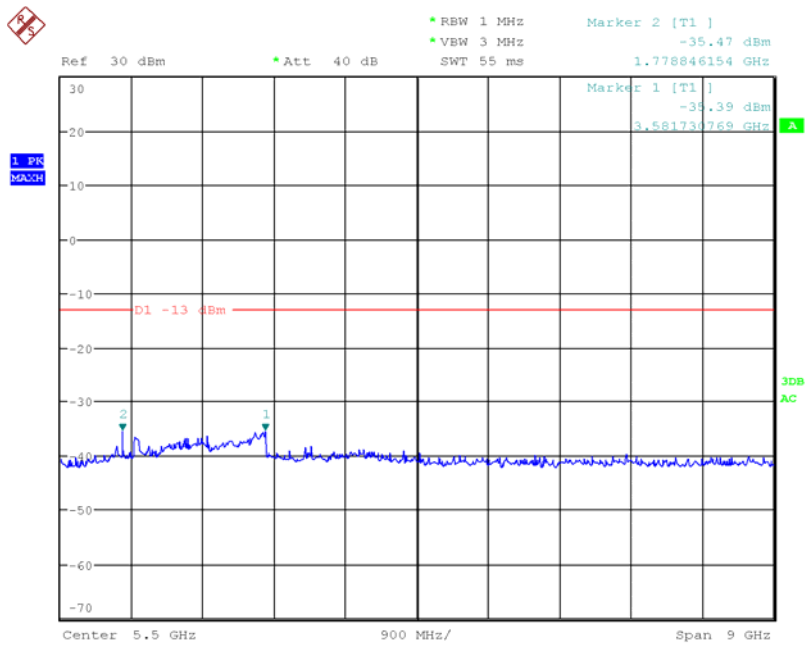

Cellular-CDMA2000 uplink (lowest frequency) 30MHz-1GHz

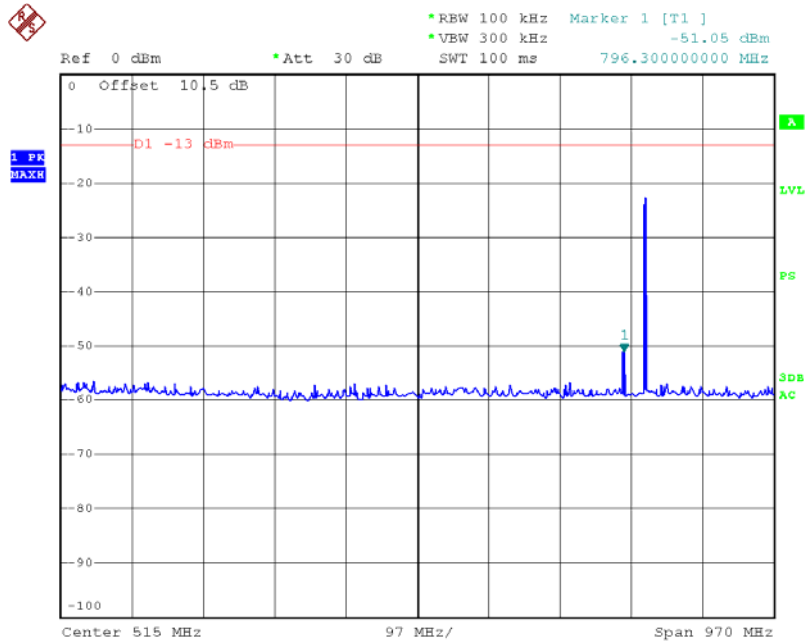

Cellular-CDMA2000 uplink (lowest frequency) Above 1GHz

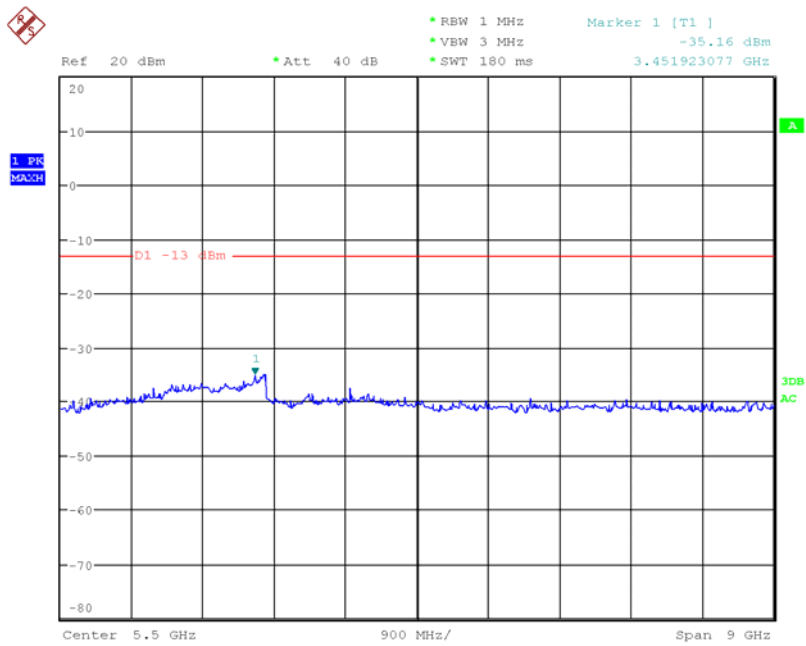

Cellular-CDMA2000 uplink (middle frequency) 30MHz-1GHz

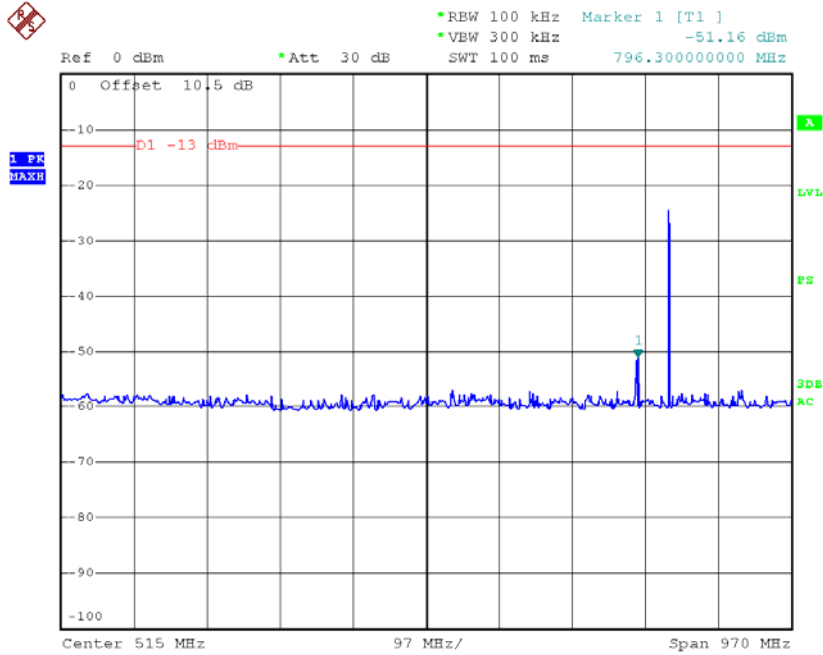

Cellular-CDMA2000 uplink(middle frequency) Above 1GHz

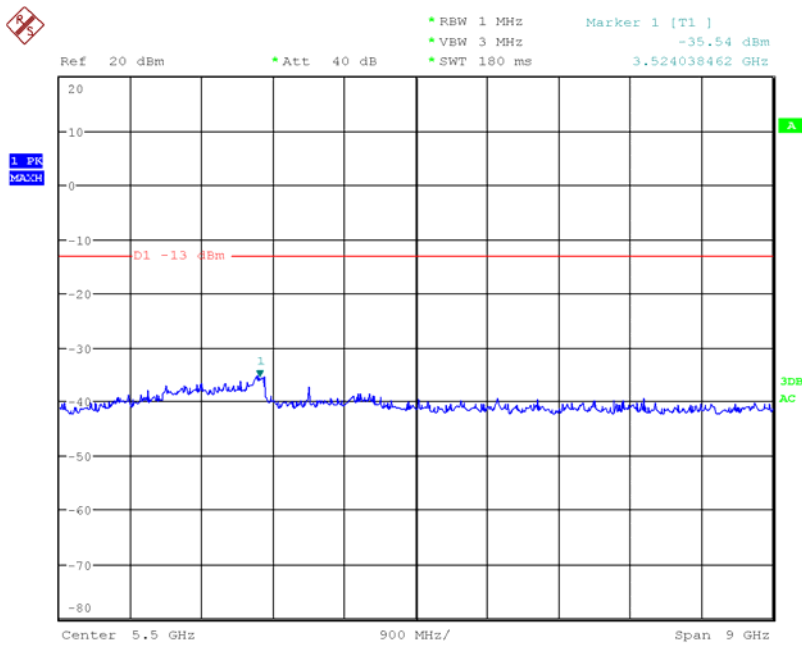

Cellular-CDMA2000 uplink (highest frequency) 30MHz-1GHz

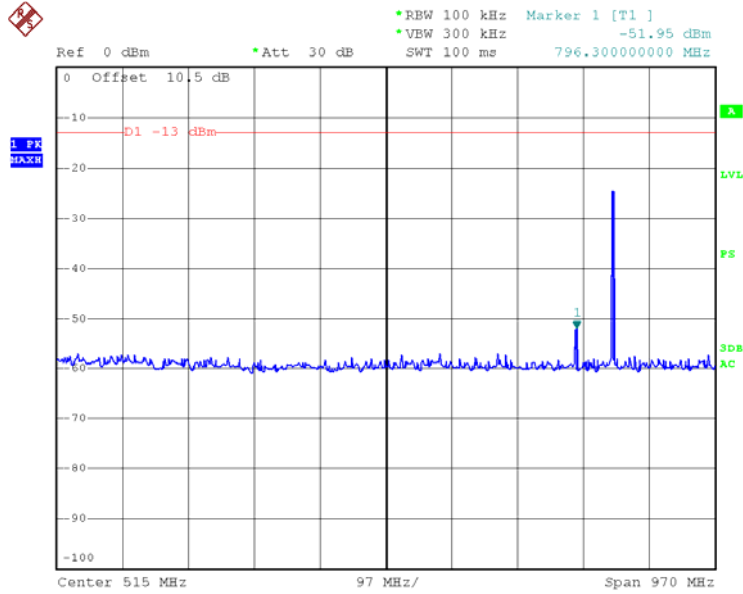

Cellular-CDMA2000 uplink (highest frequency) Above 1GHz

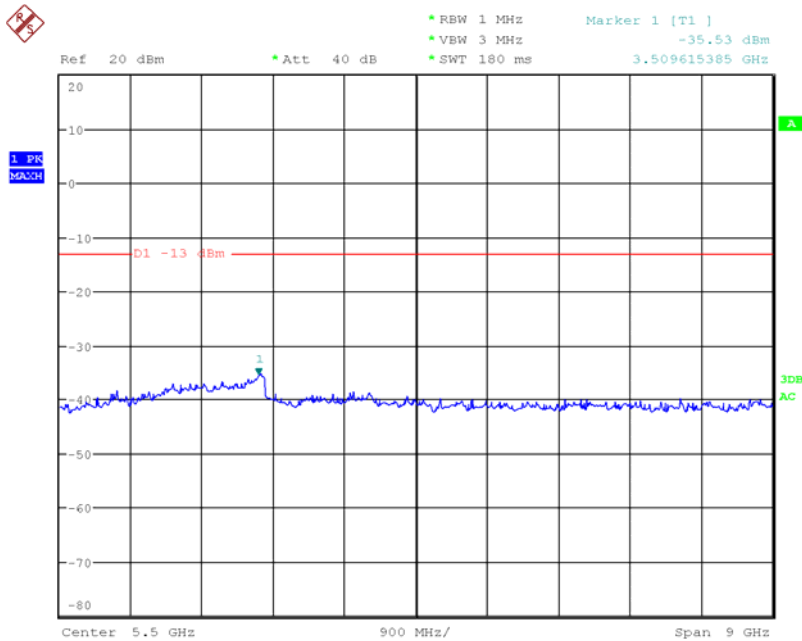

Cellular-WCDMA downlink (lowest frequency) 30MHz-1GHz

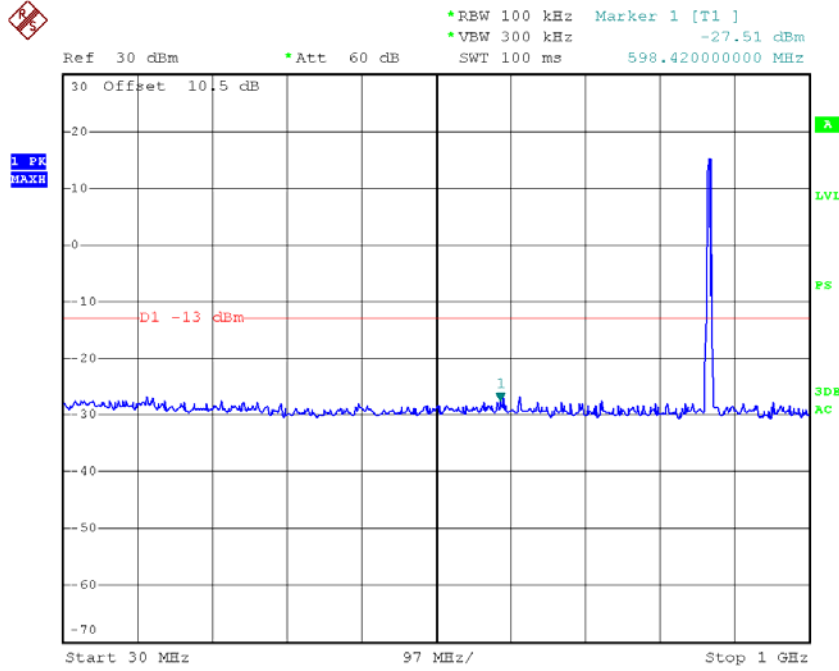

Cellular-WCDMA downlink (lowest frequency) Above 1GHz

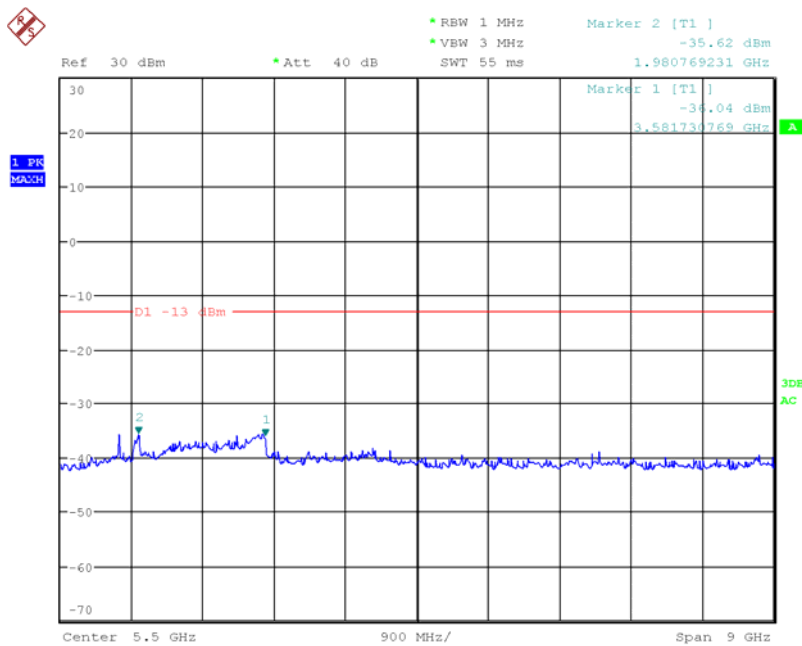

Cellular-WCDMA downlink (middle frequency) 30MHz-1GHz

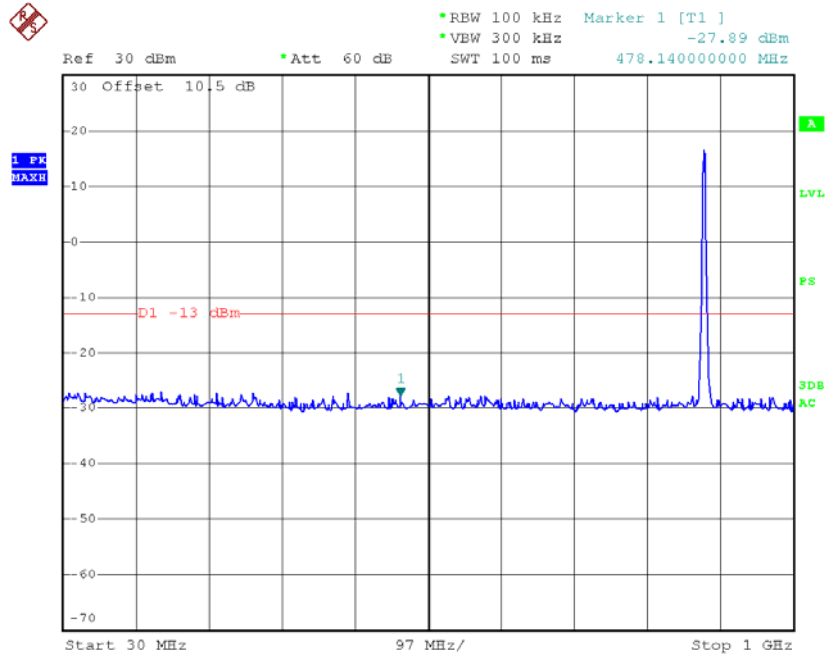

Cellular-WCDMA downlink (middle frequency) Above 1GHz

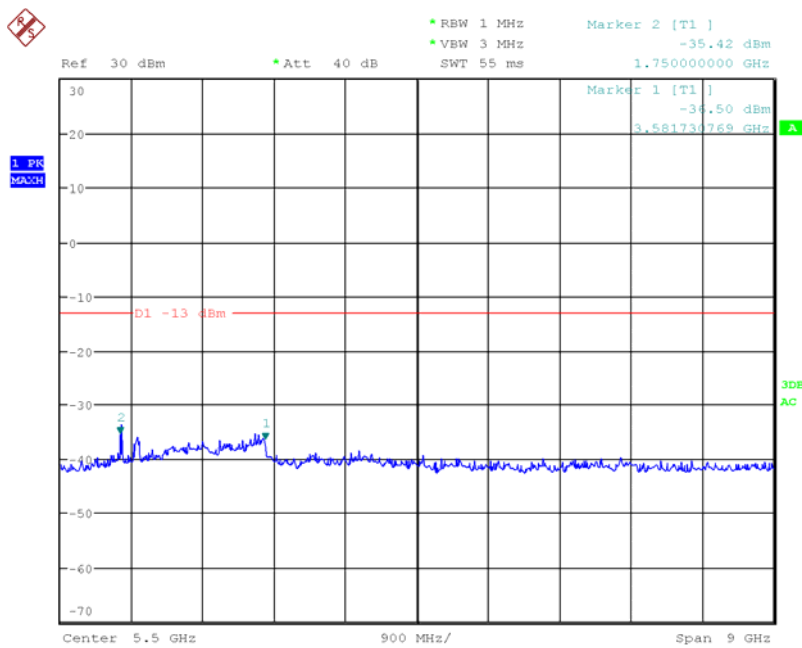

Cellular-WCDMA downlink (highest frequency) 30MHz-1GHz

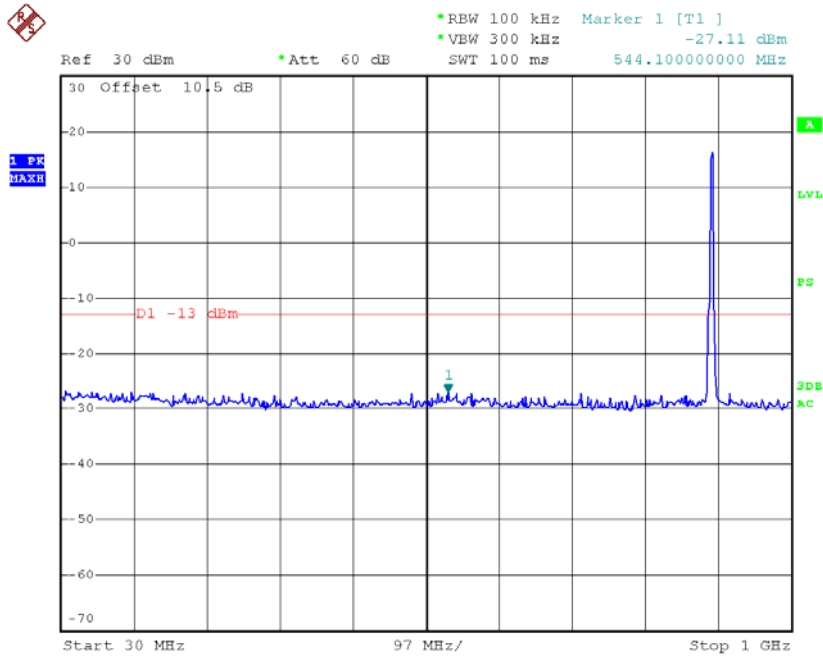

Cellular-WCDMA downlink (highest frequency) Above 1GHz

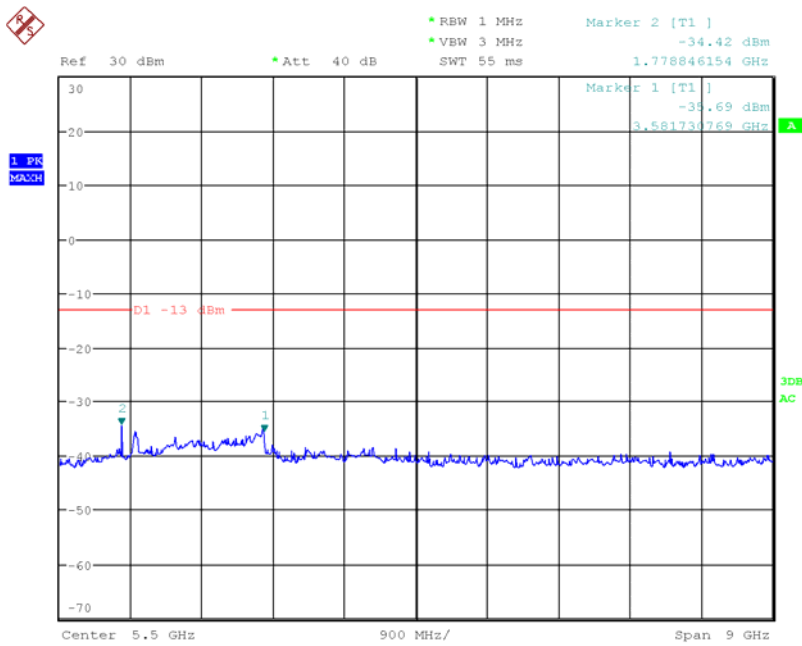

Cellular-WCDMA uplink (lowest frequency) 30MHz-1GHz

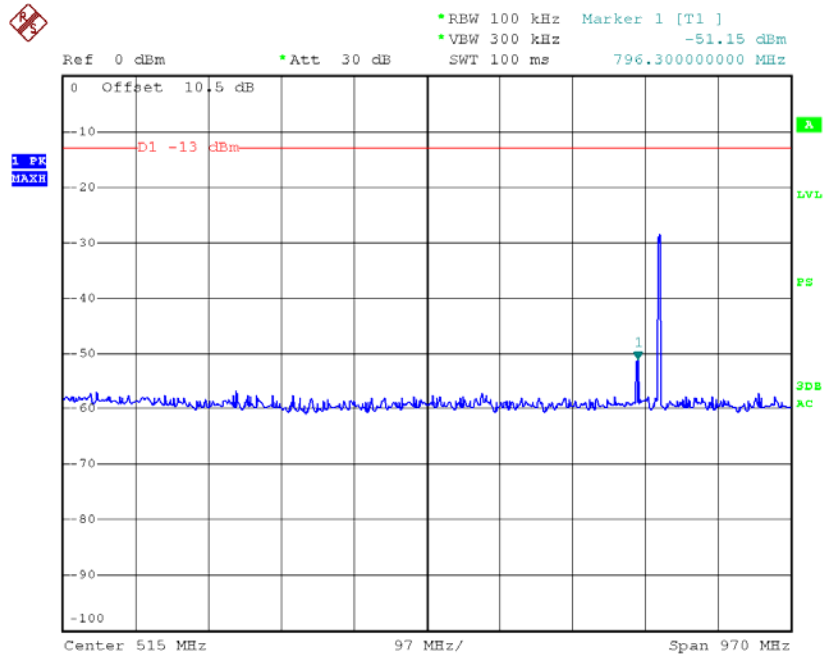

Cellular-WCDMA uplink (lowest frequency) Above 1GHz

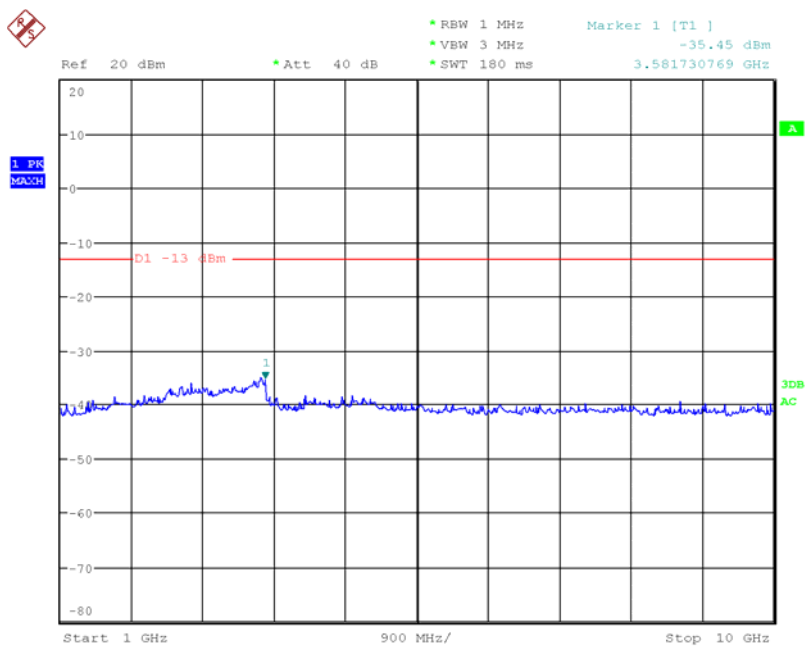

Cellular-WCDMA uplink (middle frequency) 30MHz-1GHz

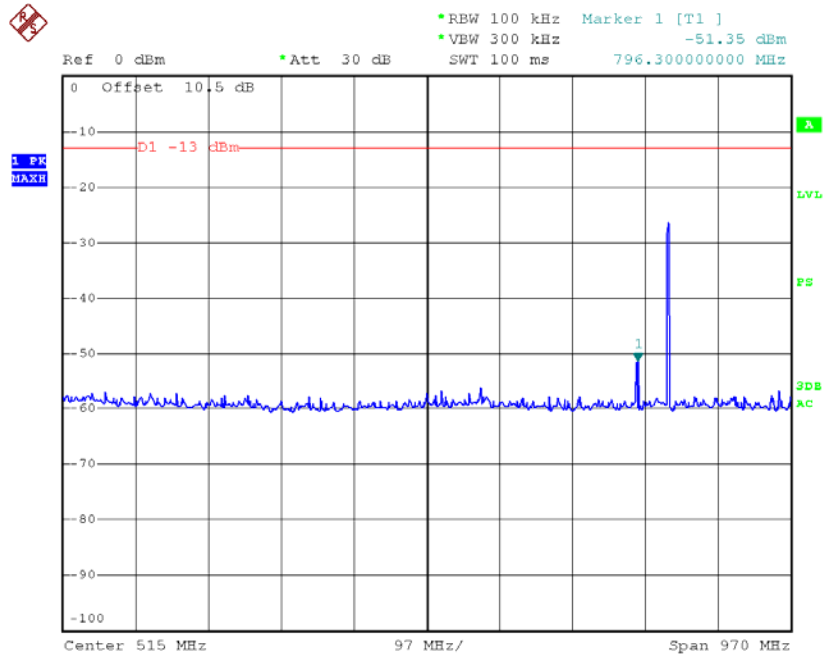

Cellular-WCDMA uplink(middle frequency) Above 1GHz

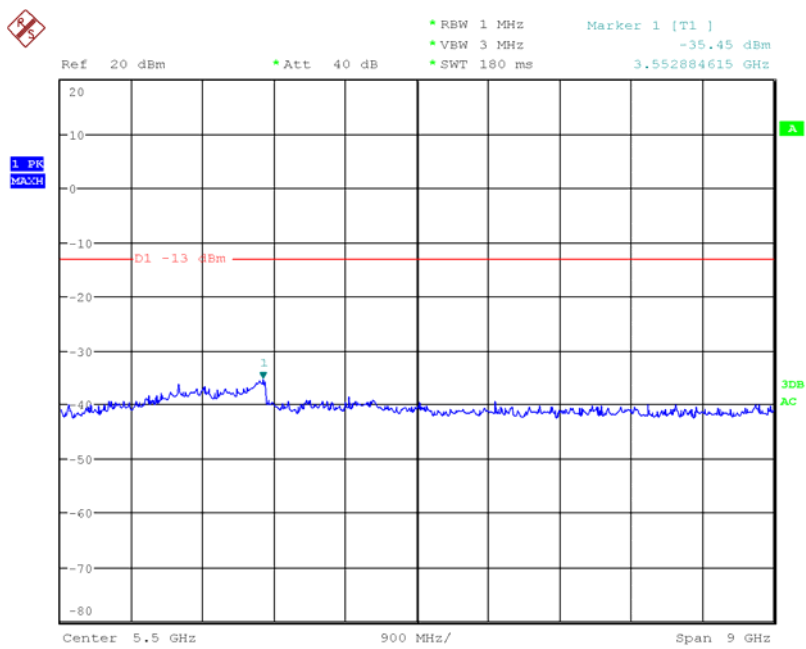

Cellular-WCDMA uplink (highest frequency) 30MHz-1GHz

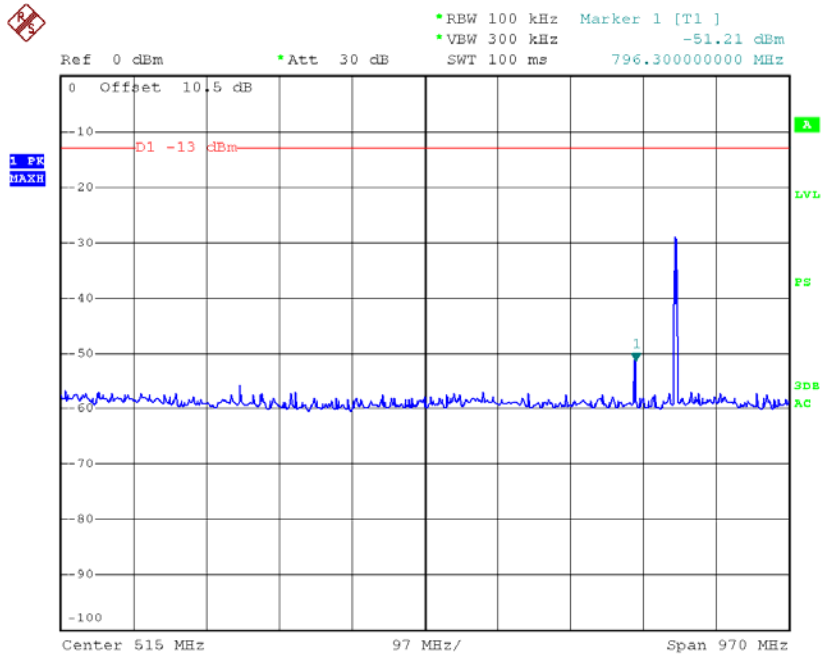

Cellular-WCDMA uplink (highest frequency) Above 1GHz

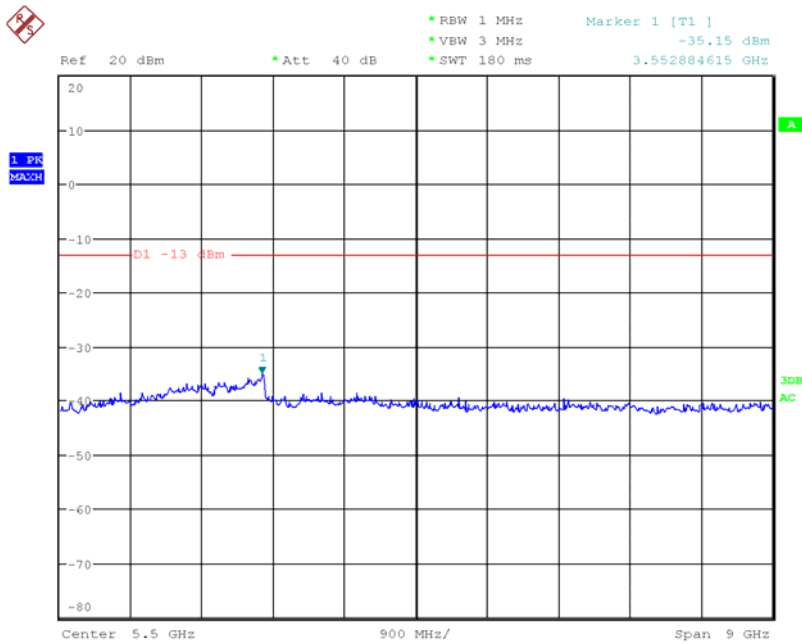

Cellular-LTE-QPSK downlink (lowest frequency) 30MHz-1GHz

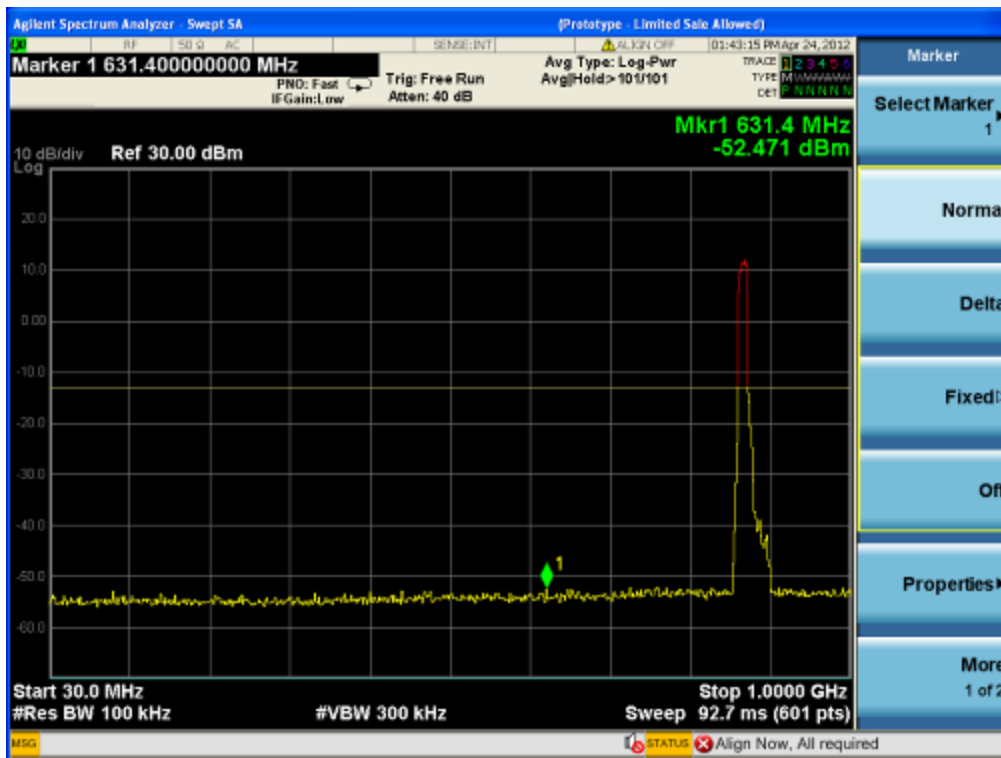

Cellular-LTE-QPSK downlink (lowest frequency) Above 1GHz

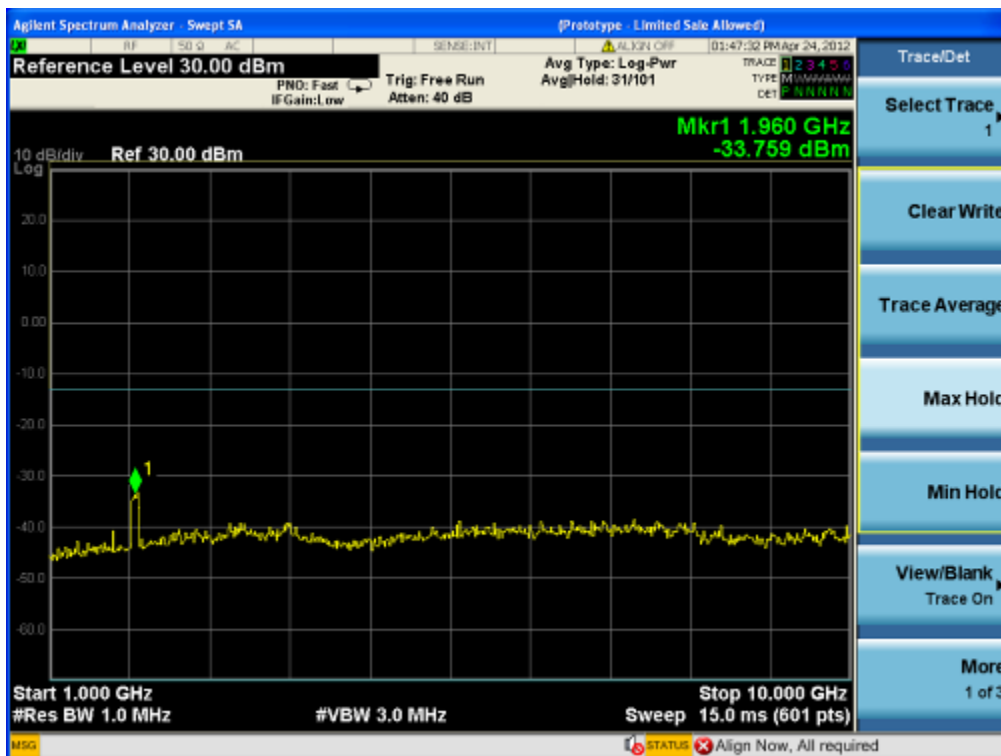

Cellular-LTE-QPSK downlink (middle frequency) 30MHz-1GHz

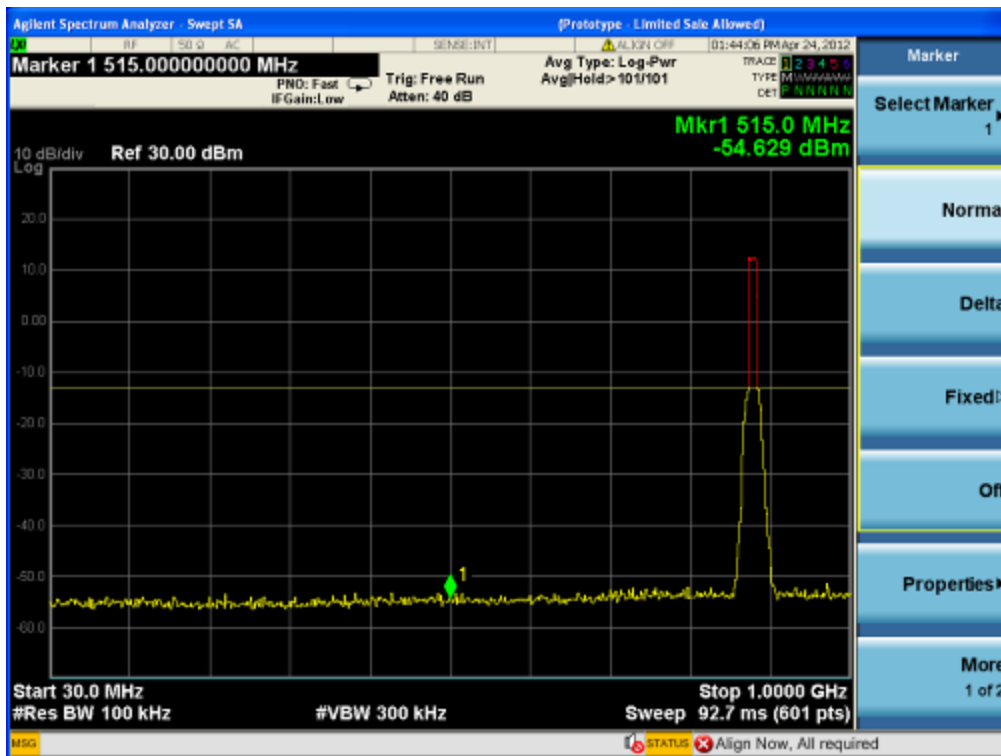

Cellular-LTE-QPSK downlink (middle frequency) Above 1GHz

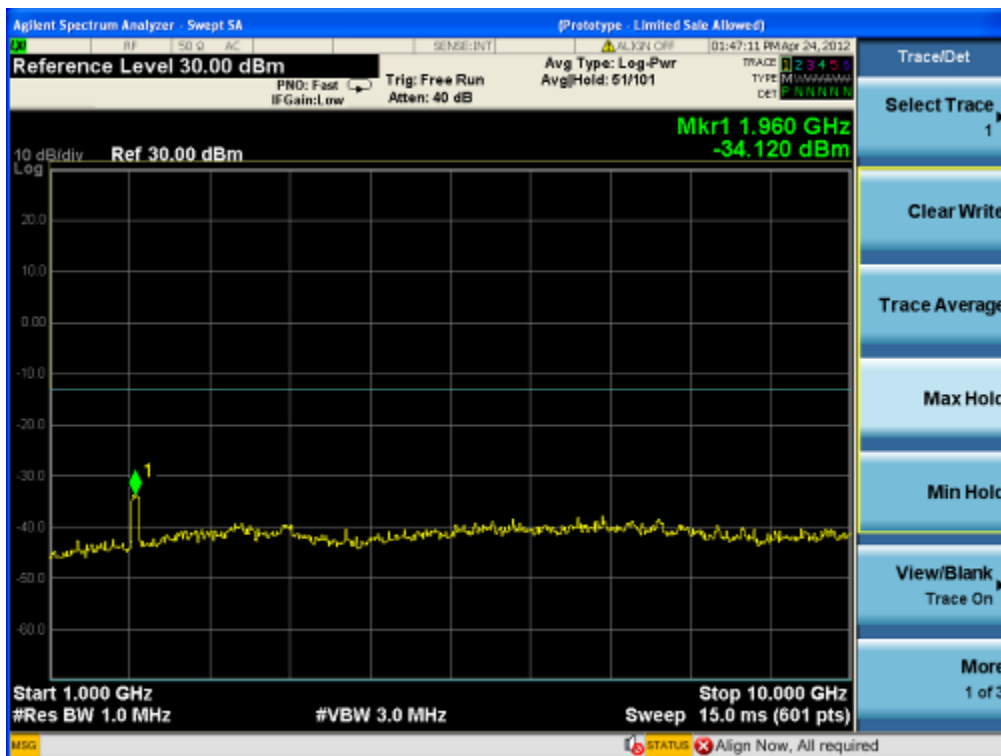

Cellular-LTE -QPSK downlink (highest frequency) 30MHz-1GHz



Cellular-LTE-QPSK downlink (highest frequency) Above 1GHz



Cellular-LTE-QPSK uplink (lowest frequency) 30MHz-1GHz

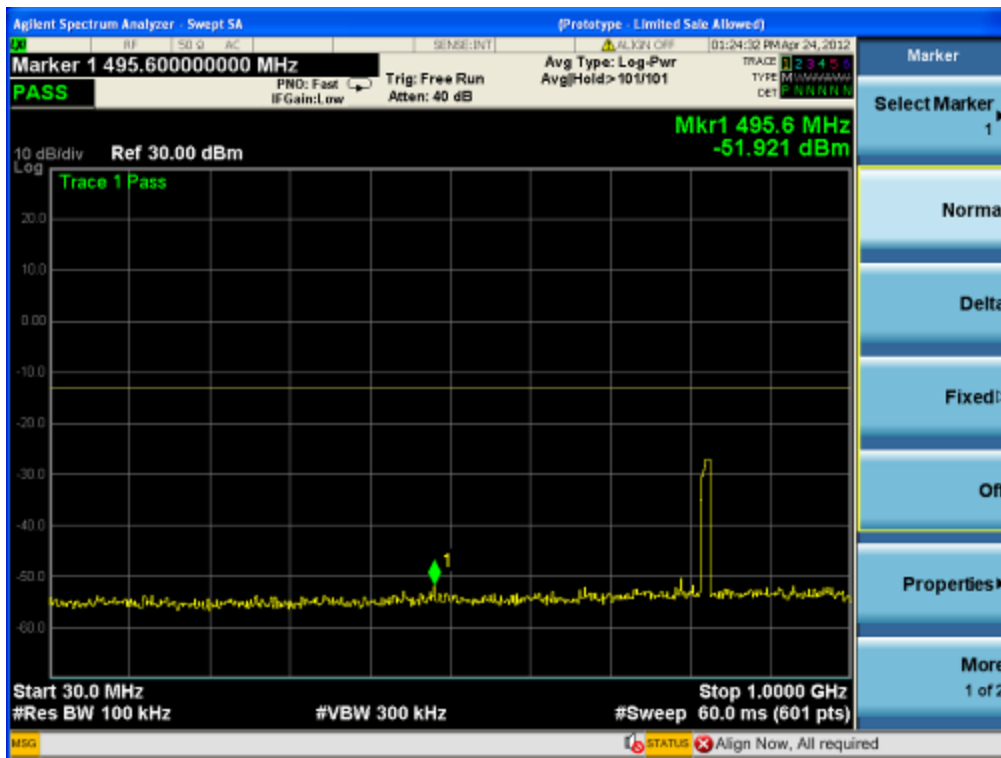

Cellular-LTE-QPSK uplink (lowest frequency) Above 1GHz

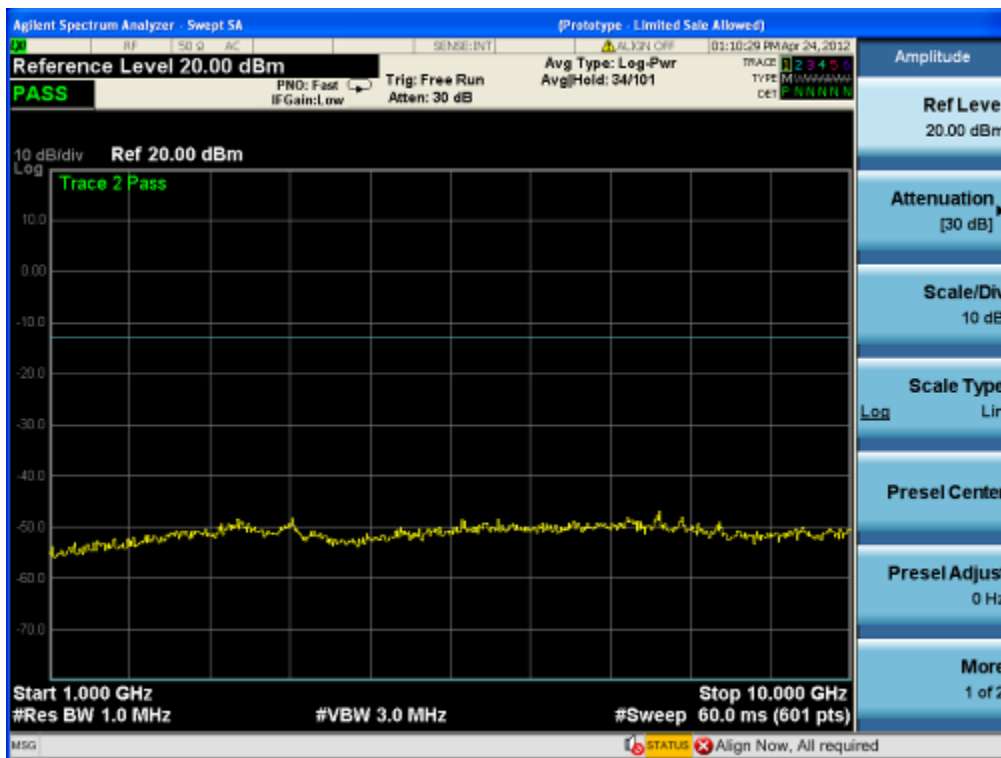

Cellular-LTE-QPSK uplink (middle frequency) 30MHz-1GHz

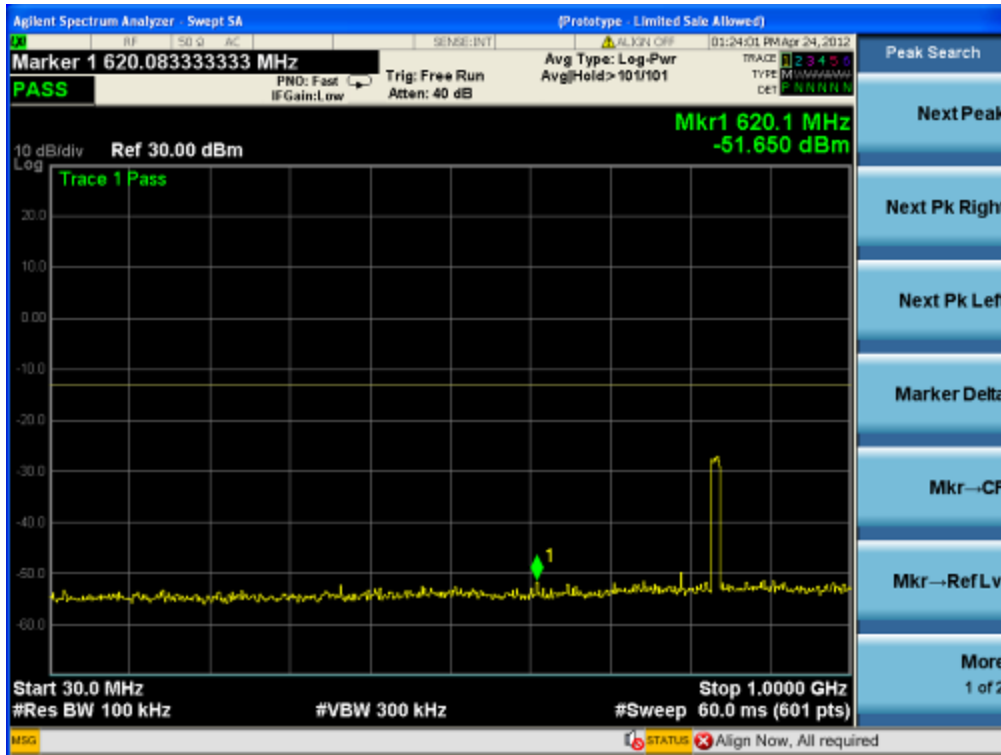

Cellular-LTE-QPSK uplink(middle frequency) Above 1GHz

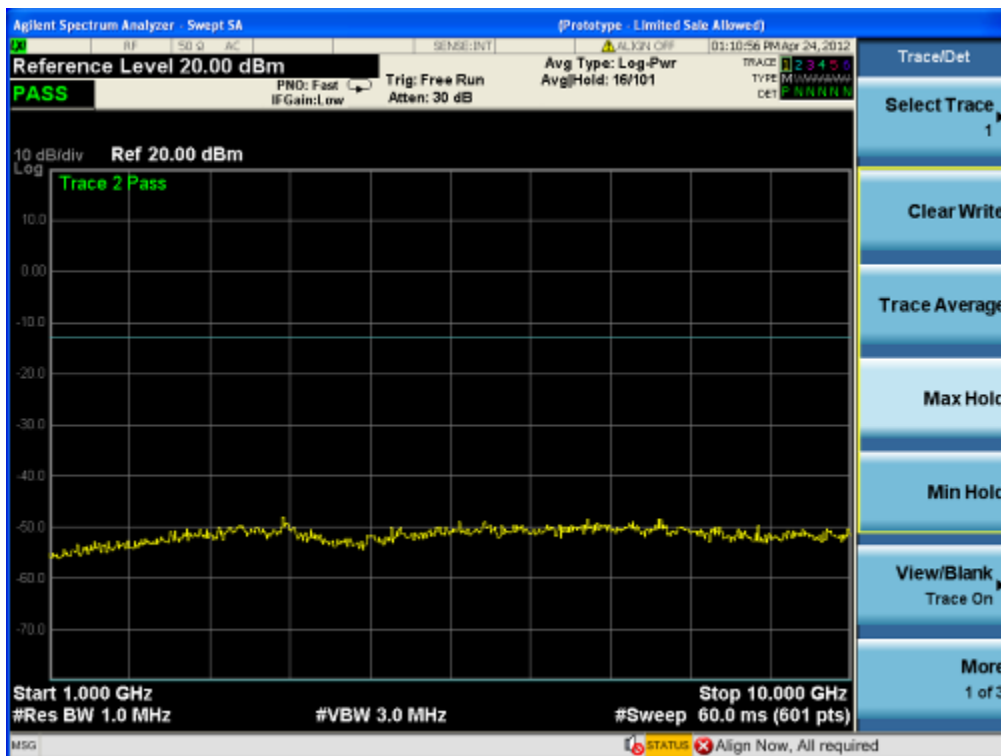

Cellular-LTE-QPSK uplink (highest frequency) 30MHz-1GHz

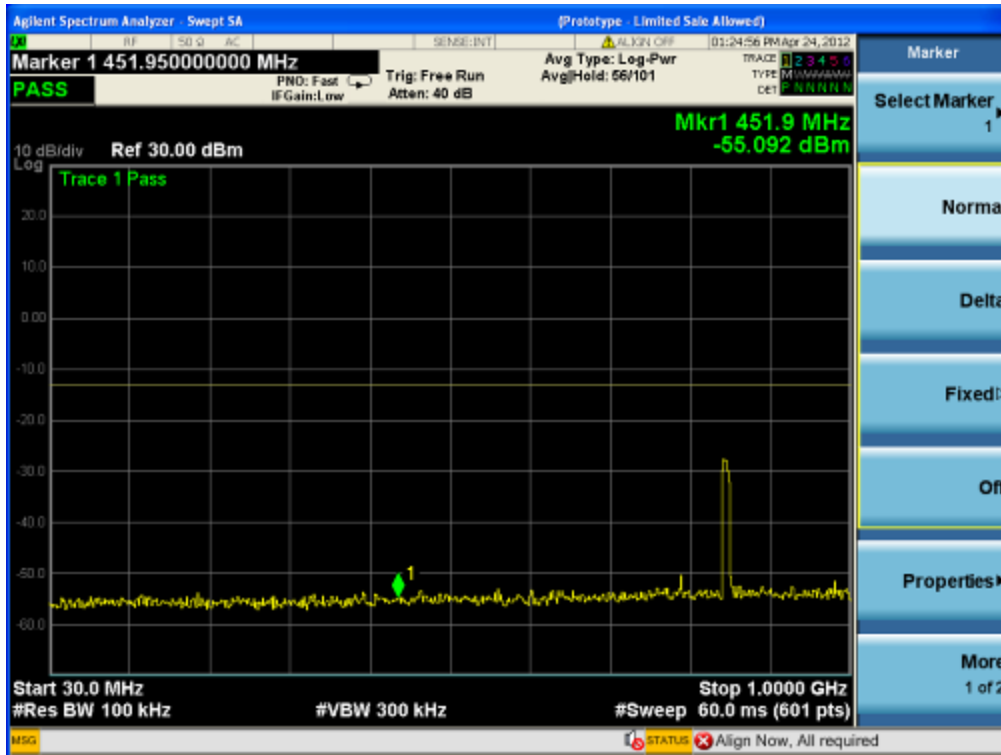

Cellular-LTE-QPSK uplink (highest frequency) Above 1GHz

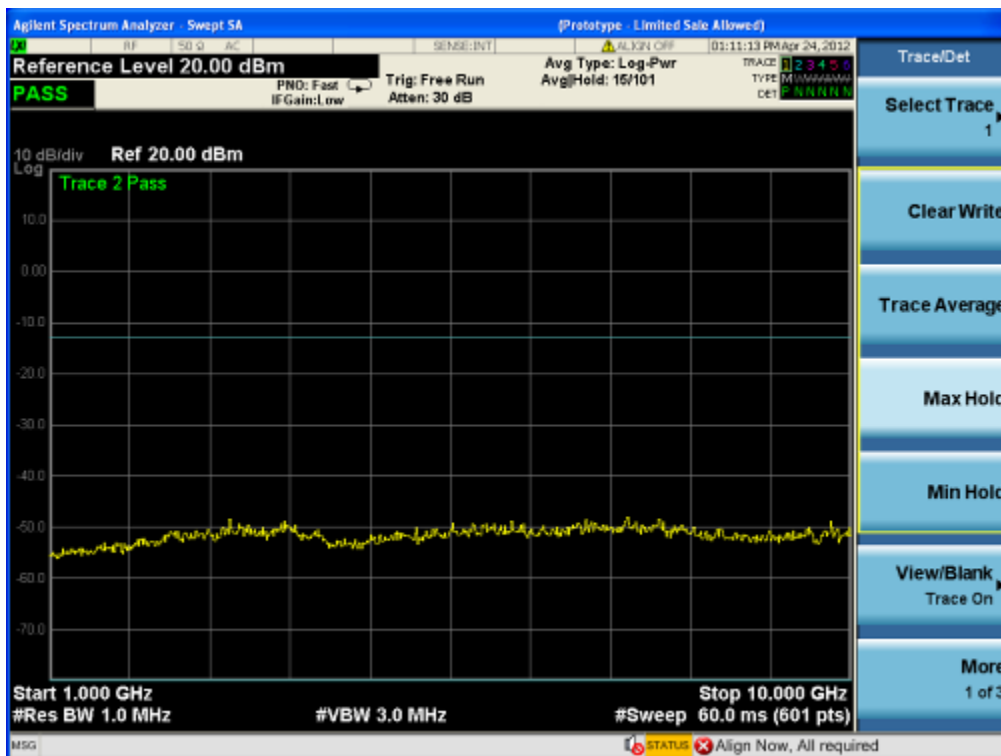

Cellular-LTE-16QAM downlink (lowest frequency) 30MHz-1GHz

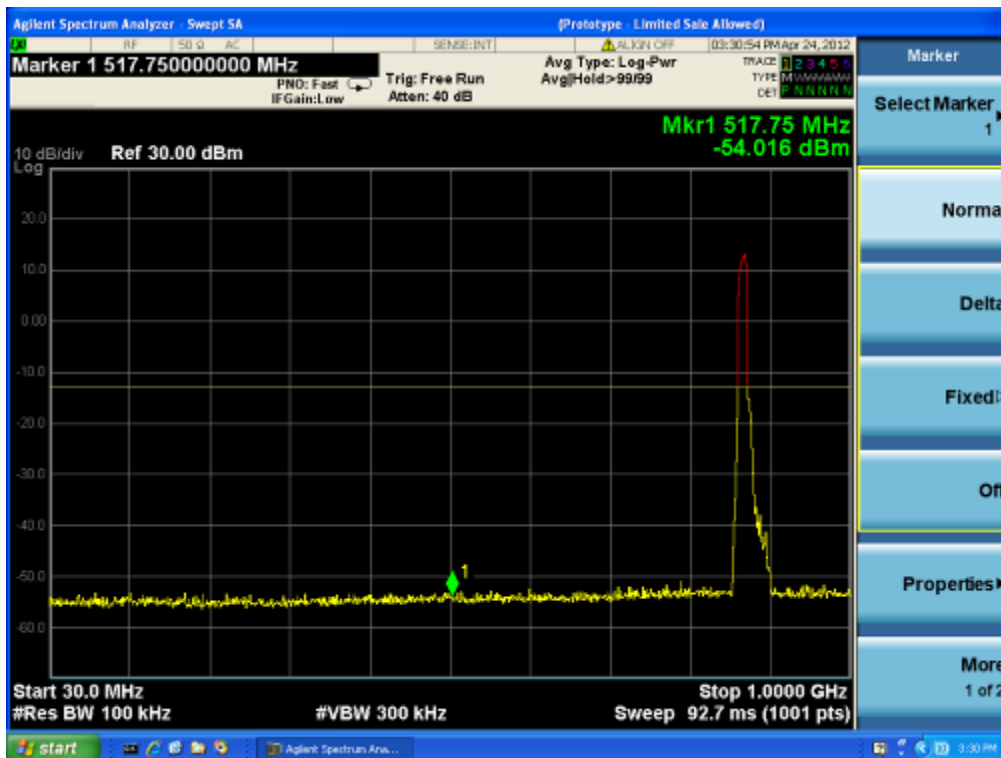

Cellular-LTE-16QAM downlink (lowest frequency) Above 1GHz



Cellular-LTE-16QAM downlink (middle frequency) 30MHz-1GHz

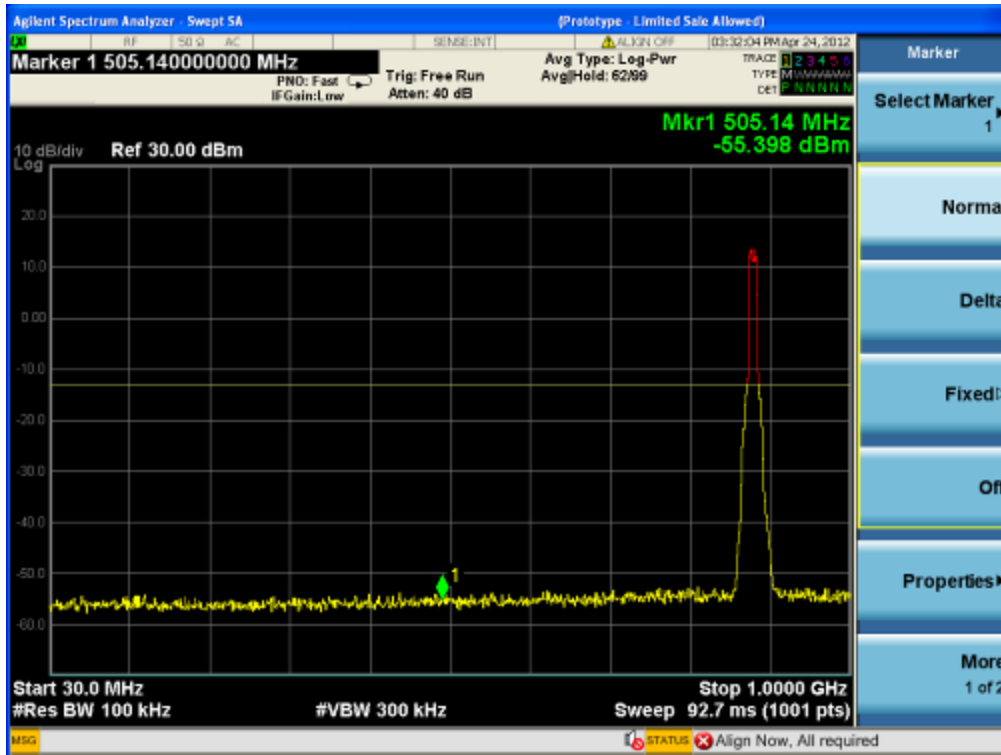

Cellular-LTE-16QAM downlink (middle frequency) Above 1GHz

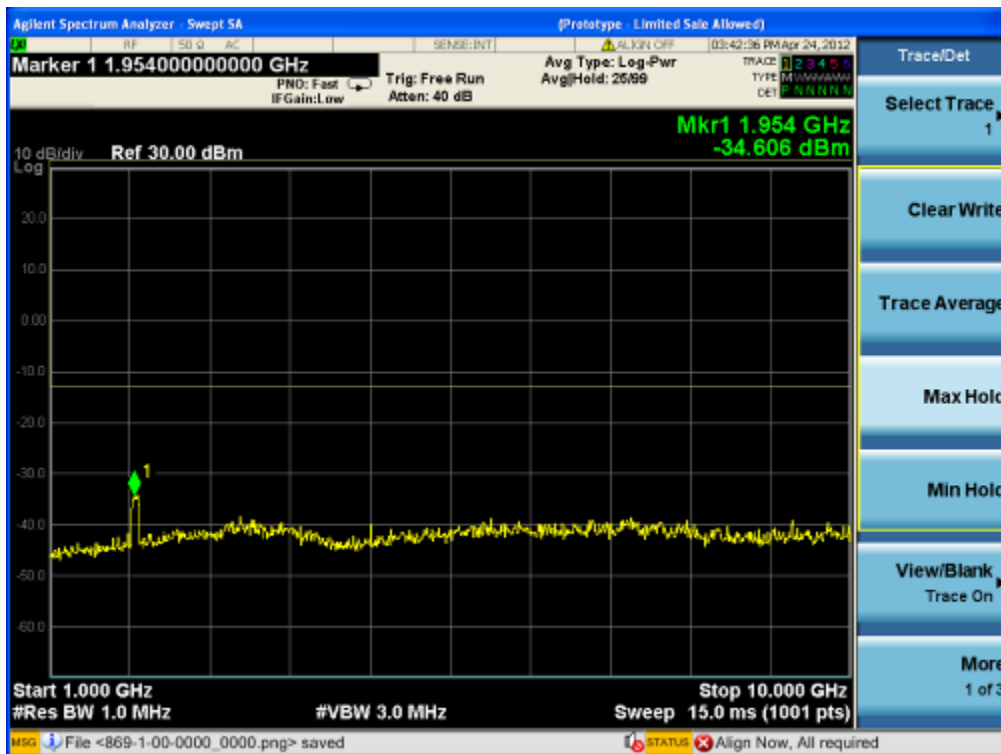

Cellular-LTE -16QAM downlink (highest frequency) 30MHz-1GHz



Cellular-LTE-16QAM downlink (highest frequency) Above 1GHz

