



# InterReach Fusion<sup>®</sup> Wideband Installation, Operation, and Reference Manual

ADCP-77-044 • Issue 2 • 10/2008



## COPYRIGHT

© 2008, ADC Telecommunications, Inc.  
All Rights Reserved

## REVISION HISTORY

ISSUE	DATE	REASON FOR CHANGE
1	7/2008	First ADC release
2	10/2008	Add Fusion Wideband 1900/AWS product content

## LIST OF CHANGES

The technical changes incorporated into this issue are listed below.

PAGE	IDENTIFIER	DESCRIPTION OF CHANGE
		-Add Fusion Wideband 1900/AWS product content

## TRADEMARK INFORMATION

ADC is a registered trademark and InterReach, InterReach Unison, InterReach Fusion, WAVEXchange, FlexWave are registered trademarks and trademarks of ADC Telecommunications, Inc. All other products, company names, service marks, and trademarks mentioned in this document or website are used for identification purposes only and may be owned by other companies.

## DISCLAIMER OF LIABILITY

Contents herein are current as of the date of publication. ADC reserves the right to change the contents without prior notice. **In no event shall ADC be liable for any damages resulting from loss of data, loss of use, or loss of profits and ADC further disclaims any and all liability for indirect, incidental, special, consequential or other similar damages. This disclaimer of liability applies to all products, publications and services during and after the warranty period.**

This publication may be verified at any time by contacting ADC's Technical Assistance Center at 1-800-366-3891, extension 73476 (in U.S.A. or Canada) or 952-917-3476 (outside U.S.A. and Canada), or by e-mail to wireless.tac@adc.com.



ADC Telecommunications, Inc.  
2540 Junction Avenue, San Jose, California 95134-1902 USA  
In U.S.A. and Canada: 1-800-530-9960  
Outside U.S.A. and Canada: 1-408-952-2400  
Fax: 1-408-952-2410

---

# Table of Contents

---

<b>SECTION 1</b>	<b>General Information</b> .....	<b>1-1</b>
	1.1 Firmware Release .....	1-1
	1.2 Purpose and Scope .....	1-1
	1.3 Conventions in this Manual .....	1-2
	1.4 Standards Conformance .....	1-3
	1.5 Related Publications .....	1-3
<b>SECTION 2</b>	<b>InterReach Fusion Wideband System Description</b> .....	<b>2-1</b>
	2.1 System Overview .....	2-1
	2.2 System Hardware Description .....	2-3
	2.3 System OA&M Capabilities Overview .....	2-5
	2.3.1 System Monitoring and Reporting .....	2-6
	2.3.2 Using Alarm Contacts .....	2-6
	2.4 System Connectivity .....	2-7
	2.5 System Operation .....	2-8
	2.6 System Specifications .....	2-9
	2.6.1 RF End-to-End Performance .....	2-11
<b>SECTION 3</b>	<b>Fusion Wideband Main Hub</b> .....	<b>3-1</b>
	3.1 Fusion Wideband Main Hub Overview .....	3-1
	3.2 Fusion Wideband Main Hub Front Panel .....	3-4
	3.2.1 Optical Fiber Uplink/Downlink Ports .....	3-5
	3.2.2 Communications RS-232 Serial Connector .....	3-5
	3.2.3 Main Hub LED Indicators .....	3-5
	3.3 Fusion Wideband Main Hub Rear Panel .....	3-8
	3.3.1 Fusion Wideband Main Hub Rear Panel Connectors .....	3-8
	3.3.1.1 9-pin D-sub Connector .....	3-8
	3.3.1.2 N-type Female Connectors .....	3-9
	3.4 Main Hub Specifications .....	3-10
	3.5 Faults, Warnings, and Status Messages .....	3-11

3.5.1 Description ..... 3-11  
3.5.2 View Preference ..... 3-12

**SECTION 4 Fusion Wideband Expansion Hub ..... 4-1**

4.1 Expansion Hub Overview ..... 4-1  
4.2 Expansion Hub Front Panel ..... 4-3  
    4.2.1 75 Ohm Type F Connectors ..... 4-4  
    4.2.2 Manufacturing RS-232 Serial Connector ..... 4-4  
    4.2.3 Optical Fiber Uplink/Downlink Connectors ..... 4-4  
    4.2.4 LED Indicators ..... 4-5  
4.3 Expansion Hub Rear Panel ..... 4-8  
4.4 Faults, Warnings, and Status Messages ..... 4-9  
4.5 Expansion Hub Specifications ..... 4-10

**SECTION 5 Remote Access Unit ..... 5-1**

5.1 RAU Overview ..... 5-1  
5.2 Remote Access Unit Connectors ..... 5-5  
    5.2.1 50 Ohm Type-N Connector ..... 5-5  
    5.2.2 75 Ohm Type-F Connector ..... 5-5  
5.3 RAU LED Indicators ..... 5-5  
5.4 Faults and Warnings ..... 5-6  
5.5 Remote Access Unit Specifications ..... 5-7

**SECTION 6 Designing a Fusion Wideband Solution ..... 6-1**

6.1 Overview ..... 6-1  
6.2 Downlink RSSI Design Goal ..... 6-3  
6.3 Maximum Output Power per Carrier ..... 6-4  
    6.3.1 800 MHz SMR ..... 6-5  
    6.3.2 850 MHz Cellular ..... 6-6  
    6.3.3 1800 MHz DCS ..... 6-7  
    6.3.4 1900 MHz PCS ..... 6-8  
    6.3.5 2100 MHz AWS ..... 6-9  
    6.3.6 2.1 GHz UMTS ..... 6-10  
    6.3.7 2.1 GHz UMTS High Power ..... 6-10  
    6.3.8 2500 MHz WiMAX ..... 6-10  
6.4 System Gain ..... 6-12  
6.5 Estimating RF Coverage ..... 6-14  
    6.5.1 Path Loss Equation ..... 6-15  
    6.5.2 RAU Coverage Distance ..... 6-16  
    6.5.3 Examples of Design Estimates ..... 6-20  
6.6 Link Budget Analysis ..... 6-22  
    6.6.1 Elements of a Link Budget for Narrowband Standards ..... 6-22

6.6.2	Narrowband Link Budget Analysis for a Microcell Application	6-25
6.6.3	Elements of a Link Budget for CDMA Standards	6-27
6.6.4	CDMA Link Budget Analysis for a Microcell Application	6-30
6.6.5	Considerations for Re-Radiation (Over-the-Air) Systems	6-33
6.7	Optical Power Budget	6-34
6.8	Connecting a Main Hub to a Base Station	6-35
6.8.1	Uplink Attenuation	6-35
6.8.2	RAU Attenuation and ALC	6-36
6.8.2.1	Using the RAU 10 dB Attenuation Setting	6-37
6.8.2.2	<b>Using the Uplink ALC Setting</b>	6-38

## **SECTION 7 Installing Fusion Wideband . . . . . 7-1**

7.1	Installation Requirements	7-1
7.1.1	Component Location Requirements	7-2
7.1.2	Cable and Connector Requirements	7-2
7.1.3	Distance Requirements	7-3
7.2	Safety Precautions	7-3
7.2.1	Installation Guidelines	7-3
7.2.2	General Safety Precautions	7-4
7.2.3	Fiber Port Safety Precautions	7-4
7.3	Preparing for System Installation	7-6
7.3.1	Pre-Installation Inspection	7-6
7.3.2	Installation Checklist	7-6
7.3.3	Tools and Materials Required	7-8
7.3.4	Optional Accessories	7-9
7.4	Fusion Wideband Installation Procedures	7-10
7.4.1	Installing a Fusion Wideband Main Hub	7-11
7.4.2	Installing Expansion Hubs	7-25
7.4.3	Installing RAUs	7-32
7.4.3.1	Troubleshooting Using RAU LEDs During Installation	7-35
7.4.4	Configuring the Fusion Wideband System	7-36
7.5	Splicing Fiber Optic Cable	7-44
7.6	Interfacing the Fusion Wideband Main Hub to an RF Source	7-46
7.6.1	Connecting a Single Fusion Wideband Main Hub to an RF Source	7-46
7.6.2	Connecting Multiple Fusion Wideband Main Hubs to an RF Source	7-51
7.7	Connecting Contact Alarms to a Fusion Wideband System	7-57
7.7.1	Alarm Source	7-58
7.7.2	Alarm Sense	7-61
7.7.3	Alarm Cables	7-63
7.8	Alarm Monitoring Connectivity Options	7-64
7.8.1	Direct Connection	7-64

7.8.2	Modem Connection	7-65
7.8.2.1	Setting Up Fusion Wideband Modem (USR Modem) Using AdminBrowser	7-65
7.8.2.2	Setting Up a PC Modem Using Windows	7-66
7.8.3	100 BASE-T Port Expander Connection	7-74
7.8.4	POTS Line Sharing Switch Connection	7-75
7.8.5	Ethernet RF Modem	7-76
7.8.6	Ethernet LAN Connection	7-77
7.8.7	SNMP Interface	7-78
<b>SECTION 8</b>	<b>Replacing Fusion Wideband Components</b>	<b>8-1</b>
8.1	Replacing an RAU	8-1
8.2	Replacing a Fusion Wideband Expansion Hub	8-3
8.3	Replacing a Fusion Wideband Main Hub	8-4
<b>SECTION 9</b>	<b>Maintenance, Troubleshooting, and Technical Assistance</b>	<b>9-1</b>
9.1	Service	9-1
9.2	Maintenance	9-2
9.3	Troubleshooting	9-3
9.3.1	Troubleshooting Using AdminBrowser	9-4
9.3.1.1	Troubleshooting Recommendations	9-4
9.3.1.2	Fault/Warning/Status Indications	9-5
9.3.2	Troubleshooting Using LEDs	9-5
9.4	Troubleshooting CATV	9-10
9.5	Technical Assistance	9-10
<b>APPENDIX A</b>	<b>Cables and Connectors</b>	<b>A-1</b>
A.1	75 Ohm CATV Cable	A-1
A.2	Fiber Optical Cables	A-6
A.3	Coaxial Cable	A-7
A.4	Standard Modem Cable	A-7
A.5	TCP/IP Cross-over Cable	A-8
A.6	DB-9 to DB-9 Null Modem Cable	A-9
<b>APPENDIX B</b>	<b>Compliance</b>	<b>B-1</b>
B.1	Fusion Wideband System Approval Status	B-1
B.2	Human Exposure to RF	B-3
<b>APPENDIX C</b>	<b>Faults, Warnings, Status Tables for Fusion, Fusion Wideband, Fusion SingleStar</b>	<b>A-1</b>
C.1	Faults Reported by Main Hubs	A-1
C.2	Faults Reported for System CPU	A-5

C.3 Faults for Expansion Hubs	A-6
C.4 Faults for RAUs	A-9
C.5 Messages for Main Hubs	A-10
C.6 Messages for System CPUs	A-15
C.7 Messages for Expansion Hubs	A-16
C.8 Messages for RAUs	A-19





# List of Figures

Figure 2-1	Fusion Wideband System Hardware	2-4
Figure 2-2	Fusion Wideband One Port System Hardware	2-4
Figure 2-3	Three Methods for OA&M Communications	2-5
Figure 2-4	System Monitoring and Reporting	2-6
Figure 2-5	Fusion Wideband's Double Star Architecture	2-7
Figure 2-6	Downlink (Base Station to Wireless Devices)	2-8
Figure 2-7	Uplink (Wireless Devices to Base Station)	2-8
Figure 3-1	Main Hub in a Fusion Wideband System	3-2
Figure 3-2	Main Hub Block Diagram	3-3
Figure 3-3	Fusion Wideband Main Hub Front Panel	3-4
Figure 3-4	Fusion Wideband Main Hub Rear Panel	3-8
Figure 3-5	Preferences Check Boxes	3-12
Figure 4-1	Expansion Hub in a Fusion Wideband System	4-1
Figure 4-2	Expansion Hub Block Diagram	4-2
Figure 4-3	Expansion Hub Front Panel	4-3
Figure 4-4	Expansion Hub Rear Panel	4-8
Figure 5-1	Remote Access Unit in a Fusion Wideband System	5-2
Figure 5-2	Remote Access Unit Block Diagram (Multiband)	5-2
Figure 6-1	Determining APL between the Antenna and the Wireless Device	6-14
Figure 6-2	ALC Operation	6-37
Figure 7-1	Flush Mounting Bracket Detail	7-12
Figure 7-2	Bracket Detail For Wall Mount Rack (PN 4712)	7-13
Figure 7-3	Installing Directly to the Wall	7-14

Figure 7-4	Using Hub Rack-Mounting Brackets for Direct Wall Installation	7-15
Figure 7-5	Protective Ground Wire Connection	7-18
Figure 7-6	DC Terminals	7-19
Figure 7-7	Power Screw Locations	7-19
Figure 7-8	Pan Head Screw Location	7-20
Figure 7-9	Recommended Hub Wire Routing	7-20
Figure 7-10	Compression Lug and Mounting Screw Locations	7-21
Figure 7-11	Grounding Wire Connection	7-22
Figure 7-12	Power Wires and Studs	7-22
Figure 7-13	Wire Polarity Illustration	7-23
Figure 7-14	DC Illustration Detail	7-23
Figure 7-15	Flush Mounting Bracket Detail	7-25
Figure 7-16	Bracket Detail For Wall Mount Rack (PN 4712)	7-26
Figure 7-17	Using Hub Rack-Mounting Brackets for Direct Wall Installation	7-27
Figure 7-18	Installing Directly to the Wall	7-28
Figure 7-19	800/850 MHz Spectrum	7-33
Figure 7-20	Fusion Wideband 800/850/1900 MHz RAU Antenna Placement Guideline	7-33
Figure 7-21	Internet Protocol (TCP/IP) Properties Window	7-37
Figure 7-22	Local Area Connection Properties Window	7-38
Figure 7-23	Set Time and Date Window	7-39
Figure 7-24	AdminBrowser Configuration Window	7-40
Figure 7-25	AdminBrowser Configuration Window for Non WiMAX	7-41
Figure 7-26	AdminBrowser Configuration Window WiMAX ONLY	7-41
Figure 7-27	Simplex Base Station to a Fusion Wideband Main Hub	7-47
Figure 7-28	Duplex Base Station to a Fusion Wideband Main Hub	7-48
Figure 7-29	Connecting a Fusion Wideband Main Hub to Multiple Base Stations	7-49
Figure 7-30	Connecting a Fusion Wideband Main Hub to a Roof-top Antenna	7-50
Figure 7-31	Connecting Two Fusion Wideband Main Hub's RF Band Ports to a Simplex Repeater or Base Station	7-53
Figure 7-32	Connecting Two Fusion Wideband Main Hub's RF Band Ports to a Duplex Repeater or Base Station	7-56
Figure 7-33	Connecting FlexWave to Fusion Wideband	7-58
Figure 7-34	Using a BTS to Monitor Fusion Wideband	7-59
Figure 7-35	Using a BTS and AdminBrowser to Monitor Fusion Wideband	7-60
Figure 7-36	Using Fusion Wideband to Monitor Unison	7-61
Figure 7-37	Alarm Sense Contacts	7-62

Figure 7-38 5-port Alarm Daisy-Chain Cable .....7-63

Figure 7-39 OA&M Direct Connection .....7-64

Figure 7-40 OA&M Modem Connection .....7-65

Figure 7-41 Default Dial-in Settings (Fusion Wideband Hub) .....7-66

Figure 7-42 Network Connections Window .....7-67

Figure 7-43 New Connection Wizard - Welcome Window .....7-67

Figure 7-44 New Connection Wizard - Network Connection Type Window ...7-68

Figure 7-45 New Connection Wizard - Network Connection Window .....7-68

Figure 7-46 New Connection Wizard - Connection Name Window .....7-69

Figure 7-47 New Connection Wizard - Phone Number to Dial Window .....7-69

Figure 7-48 New Connection Wizard - Connection Availability Window ....7-70

Figure 7-49 New Connection Wizard - Completing New Connection Window .7-70

Figure 7-50 Connect Fusion Wideband Hub Window .....7-71

Figure 7-51 Fusion Wideband Hub Properties Window .....7-71

Figure 7-52 Modem Configuration Window .....7-72

Figure 7-53 Fusion Wideband Hub Properties - Security Tab Window .....7-72

Figure 7-54 Fusion Wideband Hub Properties - Networking Tab Window ...7-73

Figure 7-55 Internet Protocol Properties Window .....7-73

Figure 7-56 OA&M Connection using a 232 Port Expander .....7-74

Figure 7-57 OA&M Connection Using a POTS Line Sharing Switch .....7-75

Figure 7-58 Cascading Line Sharing Switches .....7-76

Figure 7-59 OA&M Connection Using Ethernet and ENET/232 Serial Hub ...7-77

Figure 7-60 Fusion Wideband SNMP Configuration Options .....7-78

Figure A-1 CommScope 2065V for RG-59 ..... A-2

Figure A-2 CommScope 2279V for RG-6 ..... A-3

Figure A-3 CommScope 2293K for RG-11 ..... A-4

Figure A-1 Standard Modem Cable Pinout ..... A-7

Figure A-2 Wiring Map for TCP/IP Cable ..... A-8

Figure A-3 DB-9 Female to DB-9 Female Null Modem Cable Diagram ..... A-9



---

# List of Tables

---

Table 2-1	Physical Specifications	2-9
Table 2-2	Wavelength and Laser Power Specifications	2-10
Table 2-3	Environmental Specifications	2-10
Table 2-4	Frequency Bands Covered by Fusion Wideband RAUs	2-10
Table 2-5	2100 MHz RF End-to-End Performance	2-11
Table 2-6	1800 MHz RF End-to-End Performance	2-11
Table 2-7	2100 MHz RF End-to-End Performance	2-12
Table 2-8	800 MHz RF End-to-End Performance	2-12
Table 2-9	850 MHz RF End-to-End Performance	2-13
Table 2-10	1900 MHz RF End-to-End Performance	2-13
Table 2-11	1900 MHz RF End-to-End Performance	2-13
Table 2-12	AWS RF End-to-End Performance	2-14
Table 2-13	2500 MHz RF End-to-End Performance	2-14
Table 3-1	Fusion Wideband Hub Status LED States	3-7
Table 3-2	Fusion Wideband Hub Port LED States	3-7
Table 3-3	9-pin D-sub Pin Connector Functions	3-9
Table 3-4	Main Hub Specifications	3-10
Table 4-1	Expansion Hub Unit Status and DL/UL Status LED States	4-5
Table 4-2	Fusion Wideband Expansion Hub Port LED States	4-7
Table 4-3	9-pin D-sub Pin Connector Functions	4-8
Table 4-4	Expansion Hub Specifications	4-10
Table 5-1	Frequency Bands Covered by Fusion Wideband RAUs	5-3
Table 5-2	System Gain (Loss) Relative to CATV Cable Length	5-4
Table 5-3	Remote Access Unit LED States	5-6
Table 5-4	Remote Access Unit Specifications	5-7
Table 6-1	Power per Carrier	6-5
Table 6-2	Cellular Power per Carrier	6-6
Table 6-3	DCS Power per Carrier	6-7

Table 6-4	PCS Power per Carrier	6-8
Table 6-5	AWS Power per Carrier	6-9
Table 6-6	UMTS Power per Carrier	6-10
Table 6-7	UMTS Power per Carrier	6-10
Table 6-8	WiMAX Power per Carrier	6-10
Table 6-9	System Gain (Loss) Relative to CATV Cable Length	6-13
Table 6-10	Coaxial Cable Losses (Lcoax)	6-14
Table 6-11	Average Signal Loss of Common Building Materials	6-15
Table 6-12	Frequency Bands and the Value of the First Term in Equation (3)	6-16
Table 6-13	Estimated Path Loss Slope for Different In-Building Environments	6-16
Table 6-14	Approximate Radiated Distance from Antenna for 800 MHz SMR Applications	6-17
Table 6-15	Approximate Radiated Distance from Antenna for 850 MHz Cellular Applications	6-17
Table 6-16	Approximate Radiated Distance from Antenna for 1800 MHz DCS Applications	6-18
Table 6-17	Approximate Radiated Distance from Antenna for 1900 MHz PCS Applications	6-18
Table 6-18	Approximate Radiated Distance from Antenna for 2.1 GHz UMTS Applications	6-19
Table 6-19	Approximate Radiated Distance from Antenna for 1.7/2.1 GHz AWS Applications	6-19
Table 6-20	Approximate Radiated Distance from Antenna for 2.5 GHz WiMAX Applications	6-19
Table 6-21	Link Budget Considerations for Narrowband Systems	6-23
Table 6-22	Narrowband Link Budget Analysis: Downlink	6-25
Table 6-23	Narrowband Link Budget Analysis: Uplink	6-26
Table 6-24	Distribution of Power within a CDMA Signal	6-27
Table 6-25	Additional Link Budget Considerations for CDMA	6-28
Table 6-26	CDMA Link Budget Analysis: Downlink	6-30
Table 6-27	CDMA Link Budget Analysis: Uplink	6-32
Table 7-1	Distance Requirements	7-3
Table 7-2	Installation Checklist	7-6
Table 7-3	Tools and Materials Required for Component Installation	7-8
Table 7-4	Optional Accessories for Component Installation	7-9
Table 7-5	Troubleshooting Main Hub LEDs During Installation	7-24
Table 7-6	Troubleshooting Expansion Hub LEDs During Installation	7-31
Table 7-7	Troubleshooting RAU LEDs During Installation	7-36
Table 7-8	Alarm Types	7-57
Table 9-1	Troubleshooting Main Hub Port LEDs During Normal Operation	9-6

Table 9-2	Troubleshooting Main Hub Status LEDs During Normal Operation	9-7
Table 9-3	Troubleshooting Expansion Hub Port LEDs During Normal Operation	9-8
Table 9-4	Troubleshooting Expansion Hub Status LEDs During Normal Operation	9-9
Table 9-5	Summary of CATV Cable Wiring Problems	9-10
Table C-2	Faults for System CPU	A-5
Table C-4	Faults for RAUs	A-9
Table C-5	Warnings/Status Messages for Main Hubs	A-11
Table C-6	Warning/Status Messages for System CPUs	A-15
Table C-8	Warning/Status Messages for RAUs	A-19





# General Information

---

This section contains the following subsections:

- Section 1.1 Firmware Release . . . . . 1-1
- Section 1.2 Purpose and Scope . . . . . 1-1
- Section 1.3 Conventions in this Manual . . . . . 1-2
- Section 1.4 Standards Conformance . . . . . 1-3
- Section 1.5 Related Publications . . . . . 1-3

---

## 1.1 Firmware Release

For the latest Software and Firmware Release and associated documentation, access the ADC Customer Portal at [adc.com](http://adc.com).

---

## 1.2 Purpose and Scope

This document describes the InterReach Fusion Wideband system.

- **Section 2 InterReach Fusion Wideband System Description**

This section provides an overview of the Fusion Wideband hardware and OA&M capabilities. This section also contains system specifications and RF end-to-end performance tables.

- **Section 3 Fusion Wideband Main Hub**

This section illustrates and describes the Fusion Wideband Main Hub. This section includes connector and LED descriptions, and unit specifications.

- **Section 4 Fusion Wideband Expansion Hub**

This section illustrates and describes the Expansion Hub, as well as connector and LED descriptions, and unit specification.

- **Section 5 Remote Access Unit**

This section illustrates and describes the Remote Access Unit. This section also includes connector and LED descriptions, and unit specifications.

- **Section 6 Designing a Fusion Wideband Solution**

This section provides tools to aid you in designing your Fusion Wideband system, including tables of the maximum output power per carrier at the RAU and formulas and tables for calculating path loss, coverage distance, and link budget.

- **Section 7 Installing Fusion Wideband**

This section provides installation procedures, requirements, safety precautions, and checklists. The installation procedures include guidelines for troubleshooting using the LEDs as you install the units.

- **Section 8 Replacing Fusion Wideband Components**

This section provides installation procedures and considerations when you are replacing an Fusion Wideband component in an operating system.

- **Section 9 Maintenance, Troubleshooting, and Technical Assistance**

This section provides contact information and troubleshooting tables.

- **Appendix A Cables and Connectors**

This appendix provides connector and cable descriptions and requirements. It also includes cable strapping, connector crimping tools, and diagrams.

- **Appendix B Compliance**

This section lists safety and radio/EMC approvals.

- **Appendix C Faults, Warnings, Status Tables**

This section lists all system alarm messages.

---

## 1.3 Conventions in this Manual

The following table lists the type style conventions used in this manual.

<b>Convention</b>	<b>Description</b>
<b>bold</b>	Used for emphasis
<b>BOLD CAPS</b>	Labels on equipment
SMALL CAPS	Software menu and window selections

This manual lists measurements first in metric units, and then in U.S. Customary System of units in parentheses. For example:

0° to 45°C (32° to 113°F)

This manual uses the following symbols to highlight certain information as described.

---

**NOTE:** This format emphasizes text with special significance or importance, and provides supplemental information.

---



**CAUTION:** This format indicates when a given action or omitted action can cause or contribute to a hazardous condition. Damage to the equipment can occur.

---



**WARNING:** This format indicates when a given action or omitted action can result in catastrophic damage to the equipment or cause injury to the user.

---

### Procedure

This format highlights a procedure.

---

## 1.4 Standards Conformance

- Fusion Wideband uses the TIA-570-B cabling standards for ease of installation.
- Refer to Appendix B for compliance information.

---

## 1.5 Related Publications

- *AdminBrowser User Manual*; ADC part number D-620607-0-20
- *FlexWave Focus Configuration, Installation, and Reference Manual*; ADC part number 8500-10
- *InterReach Unison Installation, Operation, and Reference Manual*; ADC part number 8700-50

---

**Related Publications**

---

# InterReach Fusion Wideband System Description

---

This section contains the following subsections:

- Section 2.1 System Overview . . . . . 2-1
- Section 2.2 System Hardware Description . . . . . 2-3
- Section 2.3 System OA&M Capabilities Overview . . . . . 2-5
- Section 2.4 System Connectivity . . . . . 2-7
- Section 2.5 System Operation . . . . . 2-8
- Section 2.6 System Specifications . . . . . 2-9

---

## 2.1 System Overview

InterReach Fusion Wideband is an intelligent fiber optics/CATV, multi-band (frequencies) wireless networking system designed to handle both wireless voice and data communications over licensed frequencies. It provides high-quality, ubiquitous, seamless access to the wireless network in smaller buildings.

Fusion Wideband provides RF characteristics designed for large public and private facilities such as campus environments, airports, shopping malls, subways, convention centers, sports venues, and so on. Fusion Wideband uses microprocessors to enable key capabilities such as software-selectable band settings, automatic gain control, ability to incrementally adjust downlink/uplink gain, end-to-end alarming of all components and the associated cable infrastructure, and a host of additional capabilities.

The Fusion Wideband system supports major wireless standards and air interface protocols in use around the world, including:

- Frequencies: 800 MHz, 850 MHz, 1700 MHz, 1800 MHz, 1900 MHz, 2100 MHz, 2500 MHz,
- Voice Protocols: AMPS, TDMA, CDMA, GSM/EGSM, WCDMA, WiMAX

- Data Protocols: CDPD, EDGE, GPRS, WCDMA, CDMA2000, 1xRTT, EV-DO, Paging, and WiMAX

The Fusion Wideband system supports three configurable bands:

- Band 1 in 60 MHz and can be configured for 800 MHz, 1900 MHz, 2100 MHz, or 2500 MHz
- Band 2 in 75 MHz and can be configured for 1700 MHz, 1800 MHz, 1900 MHz, 2100 MHz, or 2500 MHz

Both bands support all protocols.

Fusion Wideband remote access units (RAUs) contain combinations of Band 1, Band 2, and Band 3 frequencies to support various world areas. These frequencies are 1800 MHz/2100 MHz for Europe, the Middle East, and Asia, or 800 MHz/850 MHz/1900 MHz for North America. Refer to Table 2-4 for a specific list of supported RAUs.

- Band 3 (only used for North America, FSN-W2-808519-1 RAU). This RAU's Band 3 is a 25 MHz sub-band of the 60 MHz Band and Band 1 is an 18 MHz sub-band of the 60 MHz Band.

## Key System Features

- **Multi-Band**, supports two or more full band frequencies for spectrum growth.
- **Superior RF performance**, particularly in the areas of IP3 and noise figure.
- **High downlink composite power** and **low uplink noise figure** enables support of a large number of channels and larger coverage footprint per antenna.
- **Software configurable** Main and Expansion Hubs allow the frequency bands to be configured in the field.
- **Either single-mode or multi-mode fiber** can be used, supporting flexible cabling alternatives (in addition to standard CATV 75 Ohm cabling). You can select the cabling type to meet the resident cabling infrastructure of the facility and unique building topologies.
- **Extended system “reach.”** Using single-mode fiber, fiber runs can be as long as 6 kilometers (creating a total system “wingspan” of 12 kilometers). Alternatively, with multi-mode fiber, fiber runs can be as long as 500 meters.
- **Standard 75 Ohm CATV cable**, can be run up to 130 meters for RG-59 cable; 140 meters for RG-6; 235 meters for RG-11 using CommScope 2065V, 2279V, and 2293K cables.
- **Flexible RF configuration capabilities**, including:
  - System gain:
    - Ability to manually set gain in 1 dB steps, from 0 to 15 dB, on both downlink and uplink.

- RAU:
  - RAU uplink and downlink gain can be independently attenuated 0 or 10 dB.
  - Uplink level control protects the system from input overload and can be optimized for either a single operator or multiple operators/protocols.
  - VSWR check on RAU reports if there is a disconnected antenna.
- **Firmware Updates** are downloaded (either locally or remotely) to the system when any modifications are made to the product, including the addition of new software capabilities and services.
- **OA&M capabilities**, including fault isolation to the field replaceable unit, reporting of all fault and warning conditions, and user-friendly web browser user interface OA&M software package.

---

## 2.2 System Hardware Description

The InterReach Fusion Wideband system consists of three modular components:

- 19" rack-mountable **Main Hub** (*connects to up to 4 Expansion Hubs, except for the One Port Main Hub configuration that supports 1 Expansion Hub*)
  - Converts RF signals to optical IF on the downlink; optical IF-to-RF on the uplink
  - Microprocessor controlled (for alarms, monitoring, and control)
  - Auto-configurable bands
  - Simplex interface to RF source
  - Periodically polls all downstream RAUs for system status, and automatically reports any fault or warning conditions
- 19" rack mountable **Expansion Hub** (*connects to up to 8 Remote Access Units*)
  - Optical signal conversion to electrical on the downlink; electrical to optical on the uplink
  - Microprocessor controlled (for alarms, monitoring, and control)
  - Software configurable band (based on commands from the Main Hub)
  - Supplies DC power to RAUs over CATV cable.
- **Remote Access Unit (RAU)**
  - Converts IF signals to RF on the downlink; RF-to-IF on the uplink
  - Microprocessor controlled (for alarms, monitoring, and control)
  - Multi-band protocol independent, frequency specific units

The minimum configuration of a Fusion Wideband system is one Main Hub, one Expansion Hub, and one RAU (1-1-1). The maximum configuration of a system is

one Main Hub, four Expansion Hubs, and 32 RAUs (1-4-32). Multiple systems can be combined to provide larger configurations.

---

**NOTE:** The Fusion Wideband One Port Main Hub (PN: FSN-W1-MH-1P) configuration is a cost reduced version of the Fusion Wideband Main Hub and supports *only* one Expansion Hub (up to 8 RAUs).

The Fusion Wideband One Port Main Hub is “software locked” to 1 port 2 fiber ports. Additional ports are disabled internally. *Please do not attempt to remove the front panel fiber port plate, since doing so will void the product warranty.*

---

**Figure 2-1 Fusion Wideband System Hardware**

---



**Figure 2-2 Fusion Wideband One Port System Hardware**

---





## 2.3 System OA&M Capabilities Overview

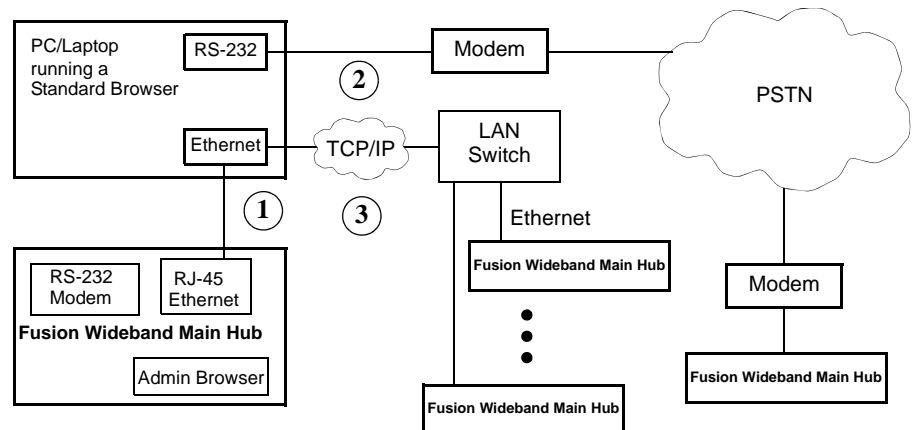
InterReach Fusion Wideband is microprocessor controlled and contains firmware to enable much of the operations, administration, and maintenance (OA&M) functionality.

Complete alarming, down to the field replaceable unit (that is, Fusion Wideband Main Hub, Expansion Hub, and Remote Access Unit) and the cabling infrastructure, is available. All events occurring in a system, defined as a Fusion Wideband Main Hub and all of its associated Expansion Hubs and Remote Access Units, are automatically reported to the Main Hub. The Main Hub monitors system status and communicates that status using the following methods:

- Normally closed (NC) alarm contact closures can be tied to standard NC alarm monitoring systems or directly to a base station for basic alarm monitoring.
- Connection Methods:
  - The Main Hub's front panel RJ-45 port connects directly to a PC (for local Ethernet access).
  - The Main Hub's front panel RS-232 serial port connects directly to a modem (for remote access).
  - Remote access is also available with an optional 100BASE-T LAN switch connections to the RJ-45 port.

**Figure 2-3 Three Methods for OA&M Communications**

Use AdminBrowser to configure or monitor a local or a remote Fusion Wideband system.



AdminBrowser OA&M software runs on the Fusion Wideband Main Hub microprocessor and communicates to its downstream Expansion Hubs and associated RAUs. Using AdminBrowser, you can perform the following from any standard web browser (Internet Explorer) running on your PC/laptop system:

- Configure a newly installed system
- Change system parameters

- Perform an end-to-end system test
- Query system status

Refer to the *AdminBrowser User Manual (D-620607-0-20)* for information about installing and using AdminBrowser software.

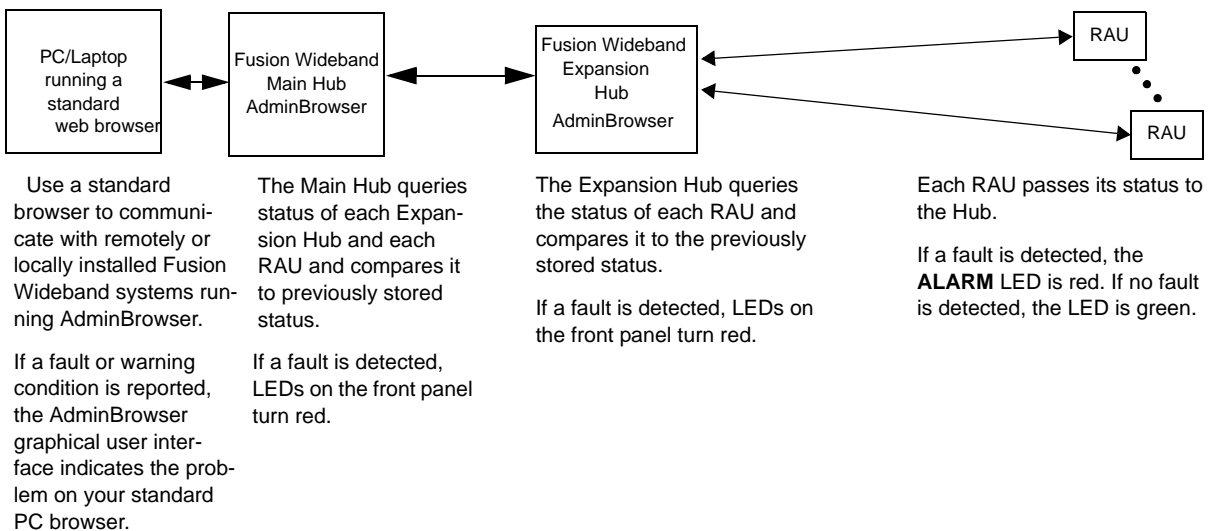
### 2.3.1 System Monitoring and Reporting

Each Fusion Wideband Main Hub in the system constantly monitors itself, its Expansion Hubs, and their downstream RAUs for internal fault and warning conditions. The results of this monitoring are stored in memory and compared against new results.

When a Main or Expansion Hub detects a change in status, it reports a fault or warning alarm. Faults are also indicated locally by red status LEDs. Both faults and warnings are reported to AdminBrowser software and displayed on a PC/laptop connected to the Main Hub's RJ-45 port. Passive antennas connected to the RAUs are not monitored automatically. Perform a System Test to retrieve status information about antennas.

Using AdminBrowser, you can install a new system or new components, change system parameters, and query system status. Figure 2-4 illustrates how the system reports its status to AdminBrowser.

**Figure 2-4 System Monitoring and Reporting**



### 2.3.2 Using Alarm Contacts

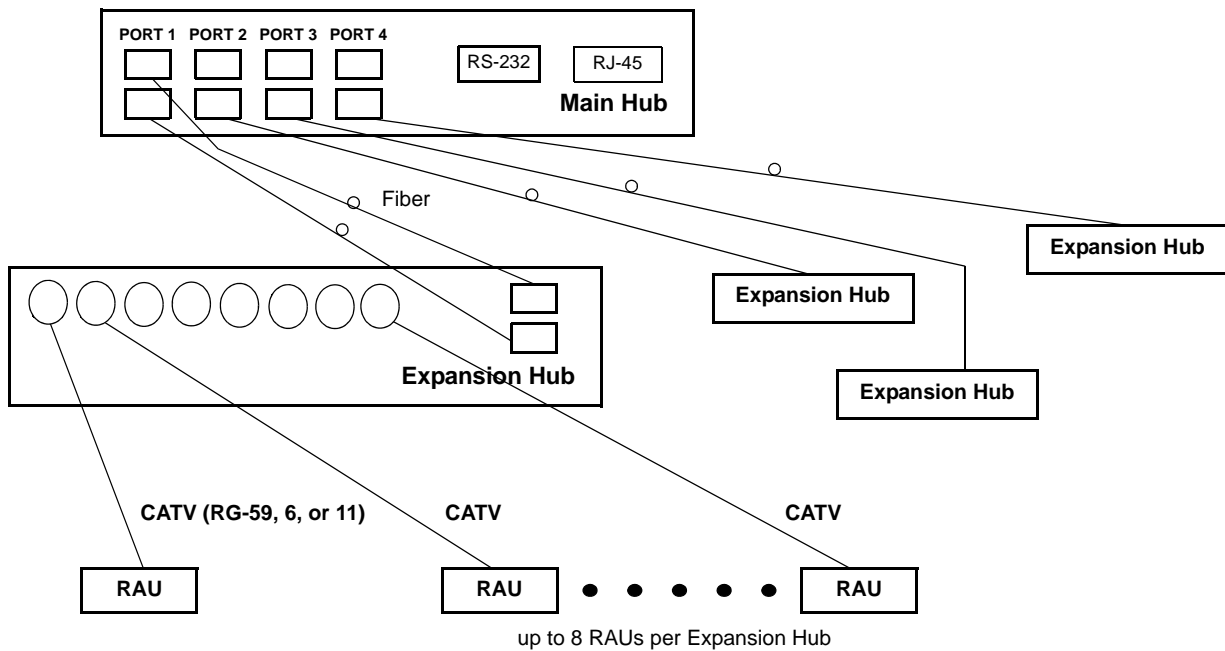
You can connect the DB-9 female connector on the rear panel of the Fusion Wideband Main Hub to a local base station or to a daisy-chained series of Fusion and/or FlexWave Focus systems.

When you connect FlexWave Focus or a BTS to the Fusion Wideband, the Fusion Wideband Main Hub outputs the alarms (alarm source) and FlexWave Focus or the BTS receives the alarms (alarm sense). This is described in Section 7.7.1 on page 7-57.

## 2.4 System Connectivity

The double star architecture of the Fusion Wideband system, illustrated in Figure 2-5, provides excellent system scalability and reliability. The system requires only one pair of fibers for eight antenna points. This makes any system expansion, such as adding an extra antenna for additional coverage, potentially as easy as pulling an extra CATV cable.

Figure 2-5 Fusion Wideband's Double Star Architecture



## 2.5 System Operation

Figure 2-6 Downlink (Base Station to Wireless Devices)

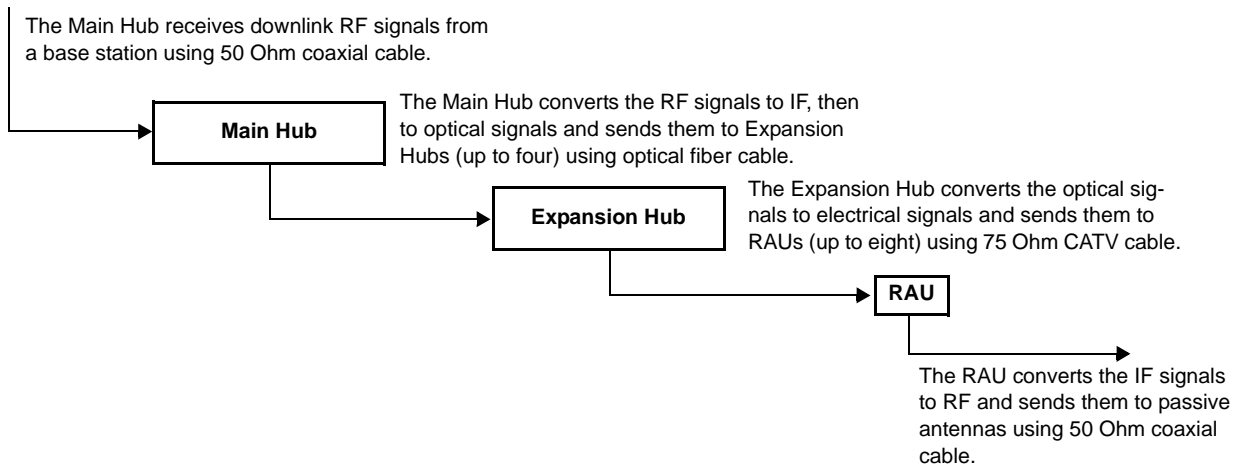
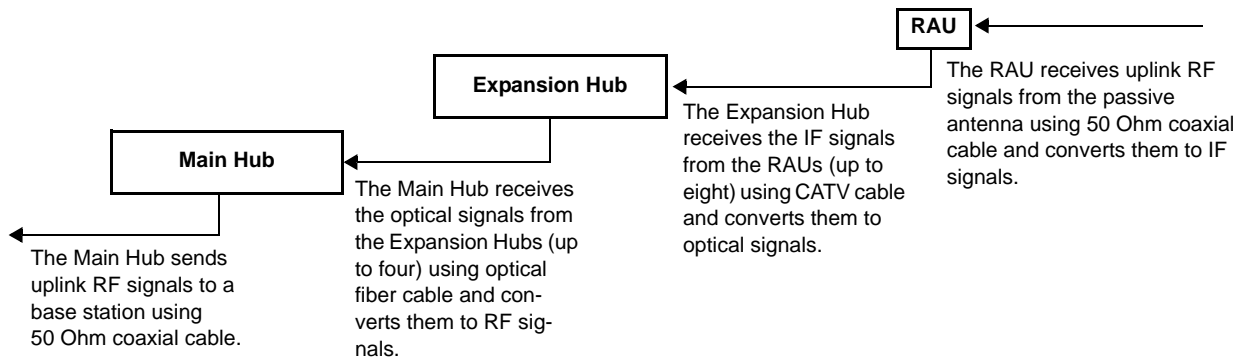


Figure 2-7 Uplink (Wireless Devices to Base Station)



## 2.6 System Specifications

Table 2-1 Physical Specifications

Parameter	Main Hub	Expansion Hub	Remote Access Unit
IF/RF Connectors	4-type N, female <sup>a</sup> (50 Ohm), 1 Downlink/Uplink pair per band	8-type F, female (CATV 75 Ohm)	One F, female (CATV -75 Ohm) One N, female <sup>b</sup> (antenna - 50 Ohm)
External Alarm Connector (contact source)	One, 9-pin D-sub, female	One, 9-pin D-sub, female	—
ADMIN/LAN Interface Connectors	One RJ-45, female One 9-pin D-sub, male for optional modem	One RJ-45, female One 9-pin D-sub, male	—
Fiber Connectors <sup>c</sup>	4 pair, SC/APC <sup>d</sup>	One pair, SC/APC	—
LED Alarm and Status Indicators	Unit Status (One pair): • Power • Main Hub Status Downstream Unit Status (One per fiber port): • Expansion Hub/RAU	Unit Status (One pair): Power and Expansion Hub Status Fiber Link Status (One pair): DL Status and UL Status Port Status: One per F connector port and Link/RAU	Unit Status (One pair): • Link • Alarm
Power (AC Option)	Rating: 100–240V AC, 1A, 50–60 Hz Operating Range: 90–132V AC/170–250V AC auto-ranging	Rating: 100–240V AC, 6A, 50–60 Hz Operating Range: 90–132V AC/170–250V AC auto-ranging	—
Power (DC Option)	Rating: 38–64V DC, 2.5A	Rating: 38–64V DC, 14A	—
Power Consumption (W)	30	4 RAUs: 240 typical, 310 Max. 8 RAUs: 400 typical, 530 Max.	—
Enclosure Dimensions <sup>e</sup> (H×W×D) (Excluding angle- brackets for 19" rack mounting of hub)	89 mm × 438 mm × 381 mm (3.5 in. × 17.25 in. × 15 in.) (2U)	89 mm × 438 mm × 381 mm (3.5 in. × 17.25 in. × 15 in.) (2U)	54 mm x 286 mm x 281 mm (2.13 in. × 11.25 in. × 11.13 in.)
Weight	< 5.5 kg (< 12 lbs.)	< 6.6 kg (< 14.5 lbs.)	< 2.1 kg (< 4.6 lbs.)

a. 6-type N, female connectors for FSN-W2-MH-1 Main Hub.

b. 2-type N, female connectors for FSN-W2-808519-1, FSN-W1-1921-1, and FSN-2500-2-WMAX RAUs.

c. It is critical to system performance that only SC/APC fiber connectors are used throughout the fiber network, including fiber distribution panels.

d. FSN-W1-MH-1P supports only one pair, SP/APC fibers.

e. Excluding angle-brackets for 19" rack mounting of hub.

**Note:** The Fusion Wideband Main Hub's typical power consumption assumes that the CATV RG-59 cable length is no more than 130 meters, the RG-6 cable length is no more than 140 meters, and RG-11 cable length is no more than 235 meters using CommScope 2065V, 2279V, and 2293K cables.

**Table 2-2 Wavelength and Laser Power Specifications**

Wavelength	Measured Output Power	
	Main Hub	Expansion Hub
1310 nm $\pm$ 20 nm	890 uW	3.8 mW

**Table 2-3 Environmental Specifications**

Parameter	Main Hub and Expansion Hub	RAU
Operating Temperature	0° to +45°C (+32° to +113°F)	-25° to +45°C (-13° to +113°F)
Non-operating Temperature	-20° to +85°C (-4° to +185°F)	-25° to +85°C (-13° to +185°F)
Operating Humidity; non-condensing	5% to 95%	5% to 95%

**Table 2-4 Frequency Bands Covered by Fusion Wideband RAUs**

Fusion Wideband RAU	Part Number	Fusion Wideband Band	RF Passband		MAIN HUB/ RAU Band	RAU Bandwidth
			Downlink (MHz)	Uplink (MHz)		
2100/1800	FSN-W1-2118-1	2100	2110-2170	1920-1980	1	60 MHz
		1800	1805-1880	1710-1785	2	75 MHz
2100 High Power (single-band RAU)	FSN-W1-21HP-1	2100	2110-2170	1920-1980	1	60 MHz
800/850/1900	FSN-W2-808519-1	800	851-869	806-824	1 (sub-band 1A)	18 MHz
		850	869-894	824-849	3 (sub-band 1B)	25 MHz
		1900 (A-F)	1930-1990	1850-1910	2	60 MHz
1900/AWS	FSN-W1-1921-1	1900 (A-F)	1930-1990	1850-1910	1	60 MHz
		AWS	2110-2155	1710-1755	2	45 MHz

Table 2-4 Frequency Bands Covered by Fusion Wideband RAUs (continued)

Fusion Wideband RAU	Part Number	Fusion Wide-band Band	RF Passband		MAIN HUB/RAU Band	RAU Band-width
			Downlink (MHz)	Uplink (MHz)		
2500/2500	FSN-2500-2-WMAX	2500	2496-2690	2496-2690	1	30 MHz
		2500	2496-2690	2496-2690	2	30 MHz

### 2.6.1 RF End-to-End Performance

The following tables list the RF end-to-end performance of each protocol.

**NOTE:** The system gain is adjustable in 1 dB steps from 0 to 15 dB, and the gain of each RAU can be attenuated 0 or 10 dB.

#### 2100/1800 RAU

Table 2-5 2100 MHz RF End-to-End Performance

Parameter	Typical	
	Downlink	Uplink
Average gain with 130 m RG-59 at 25°C (77°F) (dB)	15	15
Ripple with 130 m RG-59 (dB)	5	5
Output IP3 (dBm)	38	
Input IP3 (dBm)		-5
Output 1 dB Compression Point (dBm)	26	
Noise Figure 1 MH, 1 EH, 8 RAUs (dB)		17
Noise Figure 1 MH, 4 EH, 32 RAUs (dB)		23

Table 2-6 1800 MHz RF End-to-End Performance

Parameter	Typical	
	Downlink	Uplink
Average gain with 130 m RG-59 at 25°C (77°F) (dB)	15	15
Ripple with 130 m RG-59 (dB)	4.5	5
Output IP3 (dBm)	38	
Input IP3 (dBm)		-5
Output 1 dB Compression Point (dBm)	26	

**Table 2-6 1800 MHz RF End-to-End Performance**

Parameter	Typical	
	Downlink	Uplink
Noise Figure 1 MH, 1 EH, 8 RAUs (dB)		17
Noise Figure 1 MH, 4 EH, 32 RAUs (dB)		23

## 2100 High Power RAU

**Table 2-7 2100 MHz RF End-to-End Performance**

Parameter	Typical	
	Downlink	Uplink
Average gain with 130 m RG-59 at 25°C (77°F) (dB) * †	22	15
Ripple with 130 m RG-59 (dB)	4.5	5
Output IP3 (dBm)	44	
Input IP3 (dBm)		-5
Output 1 dB Compression Point (dBm)	33	
Noise Figure 1 MH, 1 EH, 8 RAUs (dB)		17
Noise Figure 1 MH, 4 EH, 32 RAUs (dB)		23

\* The system Downlink gain is adjustable in 1 dB steps from 7 to 22 dB (the High Power RAU adds 7 dB of Downlink gain).

† The system Uplink gain is adjustable in 1 dB steps from 0 to 15 dB.

## 800/850/1900 RAU

**Table 2-8 800 MHz RF End-to-End Performance**

Parameter	Typical	
	Downlink	Uplink
Average gain with 130 m RG-59 at 25°C (77°F) (dB)	15	15
Ripple with 130 m RG-59 (dB)	2.5	3
Output IP3 (dBm)	37	
Input IP3 (dBm)		-5
Output 1 dB Compression Point (dBm)	25	
Noise Figure 1 MH, 1 EH, 8 RAUs (dB)		17
Noise Figure 1 MH, 4 EH, 32 RAUs (dB)		23



**Table 2-9 850 MHz RF End-to-End Performance**

Parameter	Typical	
	Downlink	Uplink
Average gain with 130 m RG-59 at 25°C (77°F) (dB)	15	15
Ripple with 130 m RG-59 (dB)	2.5	3
Output IP3 (dBm)	35	
Input IP3 (dBm)		-5
Output 1 dB Compression Point (dBm)	23	
Noise Figure 1 MH, 1 EH, 8 RAUs (dB)		17
Noise Figure 1 MH, 4 EH, 32 RAUs (dB)		23

**Table 2-10 1900 MHz RF End-to-End Performance**

Parameter	Typical	
	Downlink	Uplink
Average gain with 130 m RG-59 at 25°C (77°F) (dB)	15	15
Ripple with 130 m RG-59 (dB)	3.5	4
Output IP3 (dBm)	38	
Input IP3 (dBm)		-5
Output 1 dB Compression Point (dBm)	26	
Noise Figure 1 MH, 1 EH, 8 RAUs (dB)		17
Noise Figure 1 MH, 4 EH, 32 RAUs (dB)		23

## 1900/AWS RAU

**Table 2-11 1900 MHz RF End-to-End Performance**

Parameter	Typical	
	Downlink	Uplink
Average gain with 130 m RG-59 at 25°C (77°F) (dB)	15	15
Ripple with 130 m RG-59 (dB)	3.5	4
Output IP3 (dBm)	38	
Input IP3 (dBm)		-5
Output 1 dB Compression Point (dBm)	26	
Noise Figure 1 MH, 1 EH, 8 RAUs (dB)		17
Noise Figure 1 MH, 4 EH, 32 RAUs (dB)		23

**Table 2-12 AWS RF End-to-End Performance**

Parameter	Typical	
	Downlink	Uplink
Average gain with 130 m RG-59 at 25°C (77°F) (dB)	15	15
Ripple with 130 m RG-59 (dB)	3.5	4
Output IP3 (dBm)	38	
Input IP3 (dBm)		-5
Output 1 dB Compression Point (dBm)	26	
Noise Figure 1 MH, 1 EH, 8 RAUs (dB)		17
Noise Figure 1 MH, 4 EH, 32 RAUs (dB)		23

**2500/2500 RAU**

**Table 2-13 2500 MHz RF End-to-End Performance**

Parameter	Typical	
	Downlink	Uplink
Average gain with 130 m RG-59 at 25°C (77°F) (dB)	15	15
Ripple with 130 m RG-59 (dB)	4.5	4.5
Output IP3 (dBm)	42.5	
Input IP3 (dBm)		-5
Output 1 dB Compression Point (dBm)	32	
Noise Figure 1 MH, 1 EH, 8 RAUs (dB)		17
Noise Figure 1 MH, 4 EH, 32 RAUs (dB)		23

---

# Fusion Wideband Main Hub

---

This section contains the following subsections:

- Section 3.1 Fusion Wideband Main Hub Overview . . . . . 3-1
- Section 3.2 Fusion Wideband Main Hub Front Panel . . . . . 3-4
- Section 3.3 Fusion Wideband Main Hub Rear Panel . . . . . 3-8
- Section 3.4 Main Hub Specifications . . . . . 3-10
- Section 3.5 Faults, Warnings, and Status Messages . . . . . 3-11

---

## 3.1 Fusion Wideband Main Hub Overview

The Fusion Wideband Main Hub (shown in Figure 3-1) distributes up to three individual (Band 1, 2, and 3) downlink RF signals from a base station, repeater, or Flex-Wave Focus system to up to four Expansion Hubs, which in turn distribute the signals to up to 32 Remote Access Units. The Main Hub also combines uplink signals from the associated Expansion Hubs.

Fusion Wideband is a multi-band system. One RF source (Band 1 or RF1) goes to the 60 MHz band and the other RF source (Band 2 or RF2) goes to the 75 MHz band. Band 3 (or RF3) goes to a 25 MHz sub-band of the 60 MHz band and is functional only with the 800/850/1900 RAU. The system installs in a 19" equipment rack and is usually co-located with the RF source in a telecommunications closet.

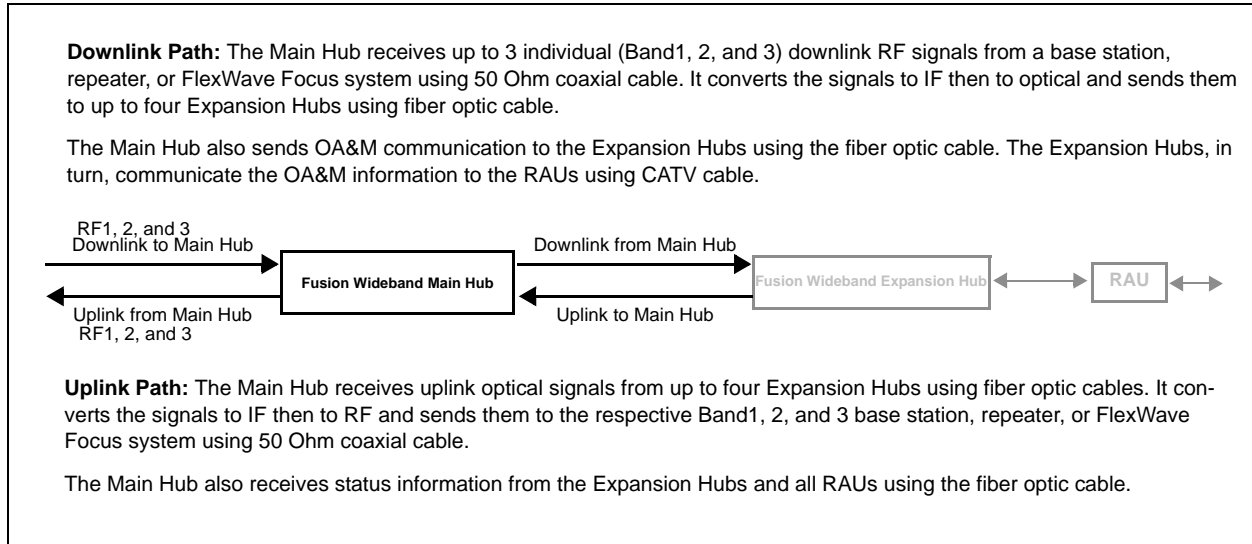
**Figure 3-1 Main Hub in a Fusion Wideband System**

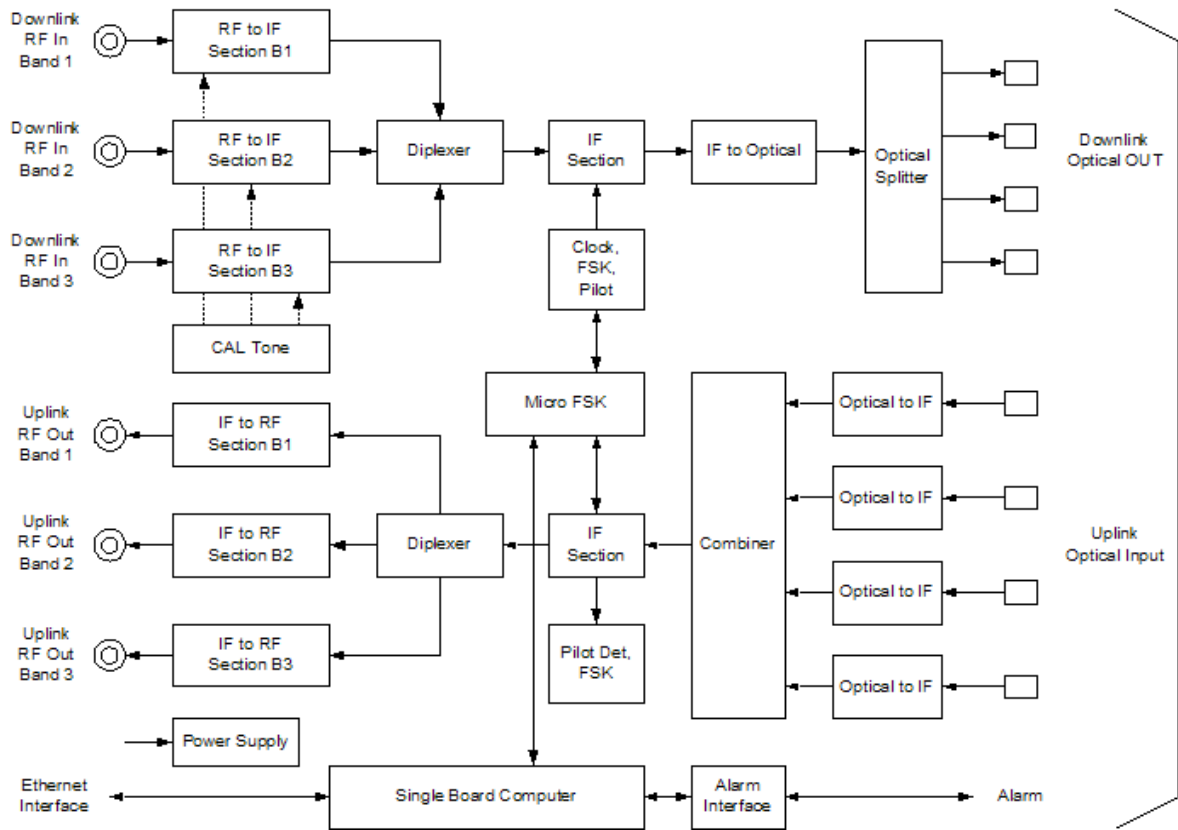
Figure 3-2 shows a detailed view of the major RF and optical functional blocks of the Main Hub.

---

**NOTE:** The Fusion Wideband One Port Main Hub (PN: FSN-W1-MH-1P) configuration is a cost reduced version of the Fusion Wideband Main Hub and supports *only* one Expansion Hub (up to 8 RAUs).

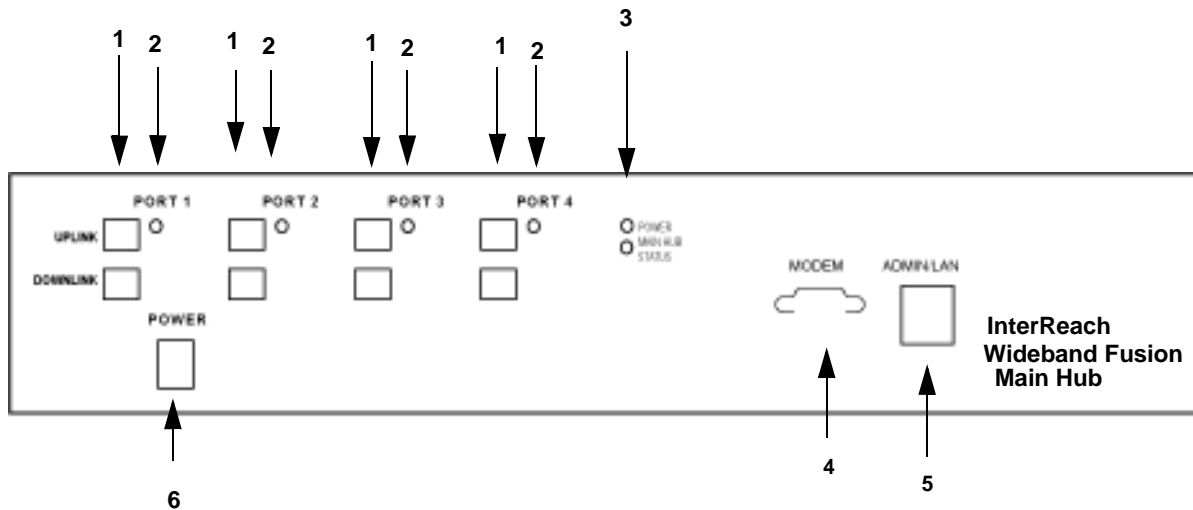
---

Figure 3-2 Main Hub Block Diagram



## 3.2 Fusion Wideband Main Hub Front Panel

Figure 3-3 Fusion Wideband Main Hub Front Panel



1. Four fiber optic ports (labeled **PORT 1**, **PORT 2**, **PORT 3**, **PORT 4**)
  - One standard female SC/APC connector per port for MMF/SMF input (labeled **UPLINK**)
  - One standard female SC/APC connector per port for MMF/SMF output (labeled **DOWNLINK**)
2. Four sets of fiber port LEDs (one set per port)
  - One LED per port for port link status and downstream unit status
3. One set of unit status LEDs
  - One LED for unit power status (labeled **POWER**)
  - One LED for unit status (labeled **MAIN HUB STATUS**)
4. One 9-pin D-sub male connector for system remote dial-up communication and diagnostics using a modem (labeled **MODEM**)
5. One RJ-45 female connector for system communication and diagnostics using a PC/laptop with direct connect or using a LAN switch (labeled **ADMIN/LAN**)
6. Power switch

**NOTE:** The Fusion Wideband One Port Main Hub (PN: FSN-W1-MH-1P) configuration is a cost reduced version of the Fusion Wideband Main Hub and supports *only* one Expansion Hub (up to 8 RAUs).

### 3.2.1 Optical Fiber Uplink/Downlink Ports

The optical fiber uplink/downlink ports transmit and receive optical signals between the Main Hub and up to four Expansion Hubs using industry-standard SMF or MMF cable. There are four fiber ports on the front panel of the Main Hub; one port per Expansion Hub. Each fiber port has two female SC/APC connectors:

- **Optical Fiber Uplink Connector**

This connector (labeled **UPLINK**) is used to receive the uplink optical signals from an Expansion Hub.

- **Optical Fiber Downlink Connector**

This connector (labeled **DOWNLINK**) is used to transmit the downlink optical signals to an Expansion Hub.



**CAUTION:** To avoid damaging the Main Hub's fiber connector ports, use only SC/APC fiber cable connectors when using either single-mode or multi-mode fiber. Additionally, it is critical to system performance that only SC/APC fiber connectors are used throughout the fiber network, including fiber distribution panels.

### 3.2.2 Communications RS-232 Serial Connector

#### Remote Monitoring

Use a standard serial cable to connect a modem to the 9-pin D-sub male serial connector for remote monitoring or configuring. The cable typically has a DB-9 female and a DB-9 female connector. Refer to Appendix A.6 on page A-9 for the cable pinout diagram.

Remote monitoring is also available by connecting the RJ-45 (ADMIN/LAN) port to a LAN switch for remote Ethernet LAN access or direct dial-up router access.

#### Local Monitoring

Use a crossover Ethernet cable (PN-4069-ADB) to connect a laptop or PC to the RJ-45 female connector for local monitoring or configuring using the AdminBrowser resident software. The cable typically has a RJ-45 male connector on both ends. Refer to Appendix A.5 on page A-8 for the cable pinout.

### 3.2.3 Main Hub LED Indicators

The unit's front panel LEDs indicate faults and commanded or fault lockouts. The LEDs do not indicate warnings or whether the system test has been performed. Use the LEDs to provide basic information only, or as a backup when you are not using AdminBrowser.

Upon power up, the Main Hub goes through a 20-second test to check the LED lamps. During this time, the LEDs blink through the states shown in Table 3-1, letting you visually verify that the LED lamps and the firmware are functioning properly. Upon completion of initialization, the LEDs stay in one of the first two states shown in Table 3-1.

The Main Hub automatically sends the program bands command to all connected RAUs. A mismatched band causes a fault message to be displayed in AdminBrowser and places the RAU in a disabled condition.

---

**NOTE:** Refer to Section 9.3.2 for troubleshooting using the LEDs.

---

---

**NOTE:** AdminBrowser should be used for troubleshooting the system. Only use LEDs for backup or confirmation. However, if there are communication problems within the system, the LEDs may provide additional information that is not available using AdminBrowser.

---

### Unit Status LEDs

The Main Hub has one pair of status LEDs, labeled **POWER** and **STATUS**, which can be in one of the states shown in Table 3-1. These LEDs can be:

- steady green
- \_steady red
- off - no color (valid only during 90 second power cycle)
- \_flashing red (60 ppm)

There is no off state when the unit's power is on.



**Table 3-1 Fusion Wideband Hub Status LED States**

	LED State	Indicates
● POWER ● STATUS	Green Green	<ul style="list-style-type: none"> <li>The Main Hub is connected to power and all power supplies are operating.</li> <li>The Main Hub is not reporting a fault; however, the system test may need to be performed or a warning condition may exist. Use AdminBrowser to determine this.</li> </ul>
● POWER ● STATUS	Green Red	<ul style="list-style-type: none"> <li>The Main Hub is connected to power and all power supplies are operating. Use AdminBrowser to power status.</li> <li>The Main Hub is reporting a fault.</li> </ul>
● POWER ● STATUS	Green Green (60-ppm)	<ul style="list-style-type: none"> <li>The Main Hub is connected to power and all power supplies are operating. Use Admin Browser to determine power status.</li> <li>The Main Hub is reporting a lockout condition.</li> </ul>
● POWER ● STATUS	Green Red (60-ppm)	<ul style="list-style-type: none"> <li>The Main Hub is connected to power and all power supplies are operating.</li> <li>The Main Hub DL input signal level is too high.</li> </ul>
● POWER ● STATUS	Red Red	<ul style="list-style-type: none"> <li>One or more power supplies are out-of-specification.</li> </ul>

**Fiber Port LEDs**

The Main Hub has one fiber port LED for each of the four fiber ports. The LED can be in one of the states shown in Table 3-2. This LED can be:

- off
- steady green
- steady red
- flashing red (60 ppm)

**Table 3-2 Fusion Wideband Hub Port LED States**

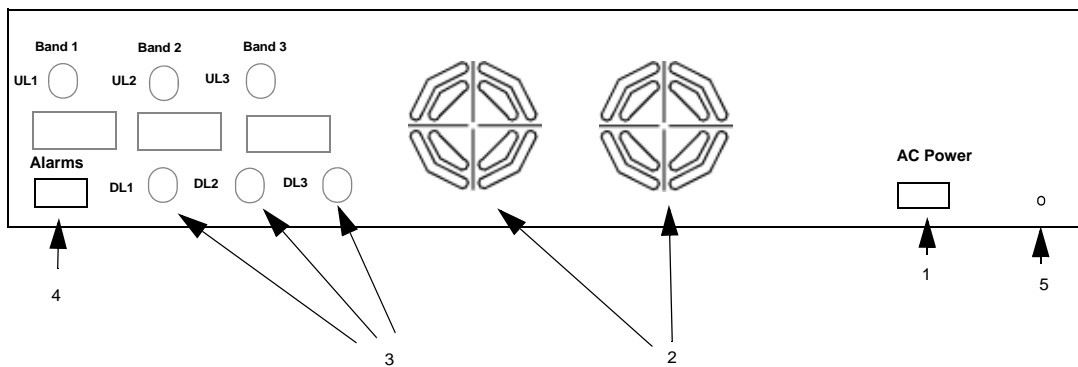
	LED State	Indicates
PORT ○	Off	<ul style="list-style-type: none"> <li>The Expansion Hub is not connected.</li> </ul>
PORT ●	Green	<ul style="list-style-type: none"> <li>The Expansion Hub is connected.</li> <li>There are no faults from the Expansion Hub or any connected RAU.</li> </ul>
PORT ●	Red (60 PPM)	<ul style="list-style-type: none"> <li>There was a loss of communications with the Expansion Hub.</li> </ul>

Table 3-2 Fusion Wideband Hub Port LED States (continued)

	LED State	Indicates
<b>PORT</b> ●	Red (Steady)	<ul style="list-style-type: none"> <li>The Expansion Hub is disconnected.</li> <li>The Expansion Hub or any connected RAU reported a fault.</li> </ul>
<b>PORT</b> ●	Green (60-ppm)	<ul style="list-style-type: none"> <li>The Expansion Hub or any connected RAU reported a lockout condition.</li> </ul>

### 3.3 Fusion Wideband Main Hub Rear Panel

Figure 3-4 Fusion Wideband Main Hub Rear Panel



1. AC power cord connector
2. Two air exhaust vents
3. Three N-type, female connectors for each band (Band 1, Band 2, and Band 3):
  - Uplink (labeled **UL1**, **UL2**, and **UL3**)
  - Downlink (labeled **DL1**, **DL2**, and **DL3**)
4. One 9-pin D-sub female connector for contact alarm monitoring (labeled **ALARMS**)
5. Ground lug for connecting unit to frame ground (labeled **GROUND**)

#### 3.3.1 Fusion Wideband Main Hub Rear Panel Connectors

##### 3.3.1.1 9-pin D-sub Connector

The 9-pin D-sub connector (labeled **ALARMS**) provides a contact alarm for fault and warning system alarm monitoring.

Table 3-3 lists the function of each pin on the 9-pin D-sub connector.

**Table 3-3 9-pin D-sub Pin Connector Functions**

Pin	Function
1	Alarm Sense Input (DC Ground)
2	Alarm Sense Input 3
3	Alarm Sense Input 2
4	Warning Source Contact (positive connection)
5	Warning Source Contact (negative connection)
6	DC Ground (common)
7	Fault Source Contact (positive connection)
8	Alarm Sense Input 1
9	Fault Source Contact (negative connection)

This interface can both generate two source contact alarms (Fault and Warning) and sense 3 single external alarm contacts (Alarm Sense Input 1 through 3).

### 3.3.1.2 N-type Female Connectors

There are two 50 Ohm N-type connector pairs for each of the 3 bands on the rear panel of the Hub:

- The **DOWNLINK** connector receives downlink RF signals from a repeater, local base station, or FlexWave Focus system.
- The **UPLINK** connector transmits uplink RF signals to a repeater, local base station, or FlexWave Focus system.

---

**CAUTION:** The **UPLINK** and **DOWNLINK** ports cannot handle a DC power feed from the local base station. If DC power is present, a DC block must be used or the Fusion Wideband hub may be damaged.

---

### 3.4 Main Hub Specifications

Table 3-4 Main Hub Specifications

Specification	Description
Enclosure Dimensions (H × W × D) <sup>a</sup> :	89 mm x 438 mm x 381 mm (3.5 in. x 17.25 in. x 15 in.) 2U
Weight	<5.5 kg (<12 lb)
Operating Temperature	0° to +45°C (+32° to +113°F)
Non-operating Temperature	-20° to +85°C (-4° to +185°F)
Operating Humidity, non-condensing	5% to 95%
External Alarm Connector (contact closure)	1 9-pin D-sub, female Maximum: 40 mA @ 40V DC Typical: 4 mA @ 12V DC
ADMIN/LAN Interface Connector	1 RJ-45, female 1 9-pin D-sub, male for optional modem
Fiber Connectors	4 Pair, SC/APC <sup>b</sup>
RF Connectors	4 N <sup>c</sup> , female (50 Ohm), 1 Downlink/Uplink pair per band
LED Fault and Status Indicators	Unit Status (1 pair): <ul style="list-style-type: none"> <li>• Power</li> <li>• Main Hub Status</li> </ul> Downstream Unit/Link Status (1 per fiber port): <ul style="list-style-type: none"> <li>• Link/E-Hub/RAU</li> </ul>
AC Power	Rating 100/240V AC, 1A, 50-60 Hz Operating Range: 90-132V AC/170-250V AC auto-ranging
Power Consumption (W)	30
MTBF	133,829 hours

a. Excluding angle brackets for the 19" rack mounting of the Hub.

b. It is critical to system performance that only SC/APC fiber connectors are used throughout the fiber network, including fiber distribution panels.

c. 6 N, female connectors for FSN-W2-MH-1

**NOTE:** The Fusion Wideband One Port Main Hub (PN: FSN-W1-MH-1P) configuration is a cost reduced version of the Fusion Wideband Main Hub and supports *only* one Expansion Hub (up to 8 RAUs).

## 3.5 Faults, Warnings, and Status Messages

### 3.5.1 Description

The Fusion Wideband Main Hub monitors and reports changes or events in system performance to:

- Ensure that fiber receivers, amplifiers and IF/RF paths are functioning properly.
- Ensure that Expansion Hubs and Remote Access Units are connected and functioning properly.

An event is classified as fault, warning, or status message.

- Faults are service impacting.
- Warnings indicate a possible service impact.
- Status and informational messages are generally not service impacting.

The Fusion Wideband Main Hub periodically queries attached Expansion Hub and Remote Access Units for their status. Both faults and warnings are reported to a connected PC/laptop running a standard browser communicating with the Admin-Browser software. Only faults are indicated by the faceplate LEDs.

For more information regarding the events, refer to:

- Appendix C for Main Hub faults.
- Appendix C for Main Hub warnings.
- Appendix C for Main Hub status messages.
- Section 9 for troubleshooting Main Hub LEDs.

### 3.5.2 View Preference

AdminBrowser 1.0 or higher enables you to select (using the screen shown in Figure 3-5) the type of events to be displayed.

Figure 3-5 Preferences Check Boxes



To modify the setting, using AdminBrowser, select Alarms → Set Alarm Preference and select the desired choice. After you click OK, AdminBrowser refreshes and updates the tree view according to the new setting.

**NOTE:** The setting is strictly visual and only in AdminBrowser. There is no affect on the hardware itself. By default, the event filtering is set to “Enable viewing of Faults only”.

The only exception to when the event filtering is ignored is during the Install/Configure command. All events are displayed regardless of the event filtering setting. This ensures a smooth installation.

# Fusion Wideband Expansion Hub

This section contains the following subsections:

- Section 4.1 Expansion Hub Overview ..... on 4-1
- Section 4.2 Expansion Hub Front Panel ..... on 4-3
- Section 4.3 Expansion Hub Rear Panel ..... on 4-8
- Section 4.4 Faults, Warnings, and Status Messages ..... on 4-9
- Section 4.5 Expansion Hub Specifications ..... on 4-10

## 4.1 Expansion Hub Overview

The Expansion Hub acts an interface between the Main Hub and the Remote Access Unit(s) by converting optical signals to electrical signals and vice versa, as shown in Figure 4-1. It also supplies control signals and DC power to operate the Remote Access Unit(s) as well as passing status information from the RAUs to the Main Hub.

**Figure 4-1 Expansion Hub in a Fusion Wideband System**

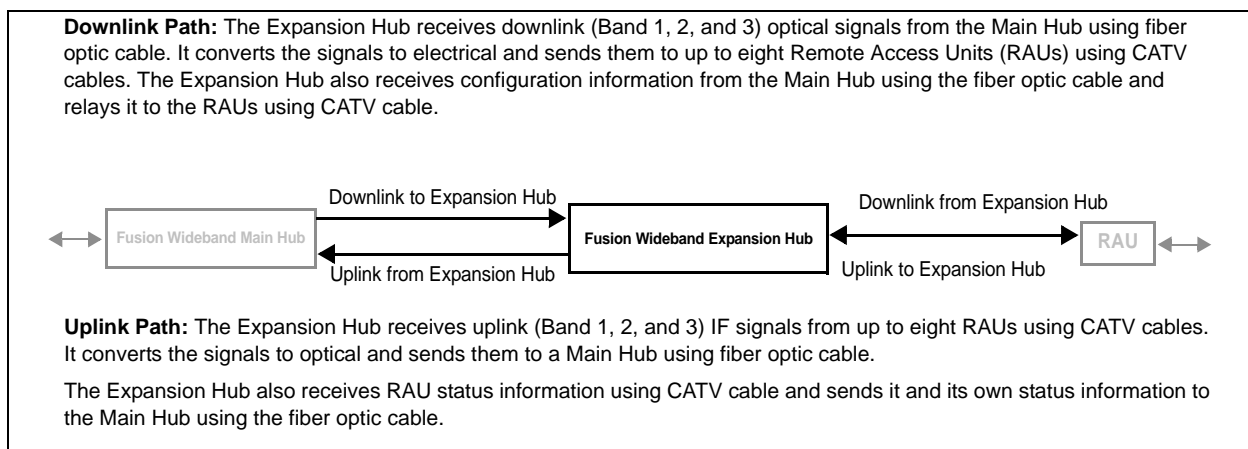
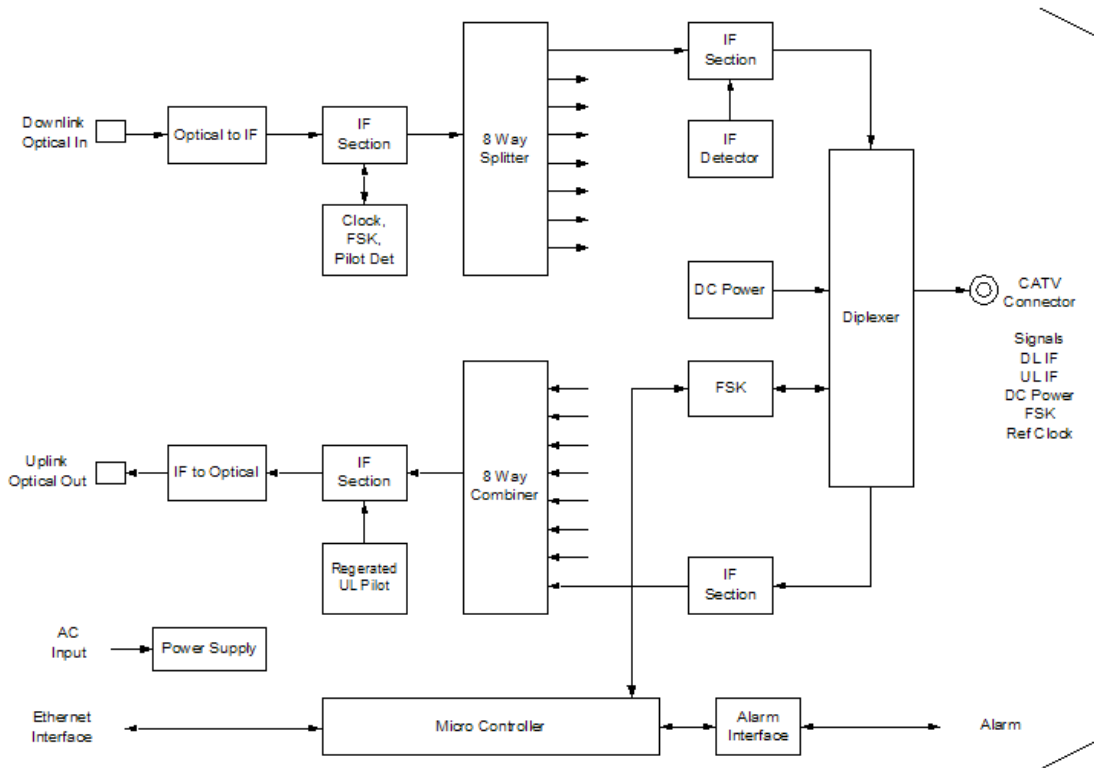


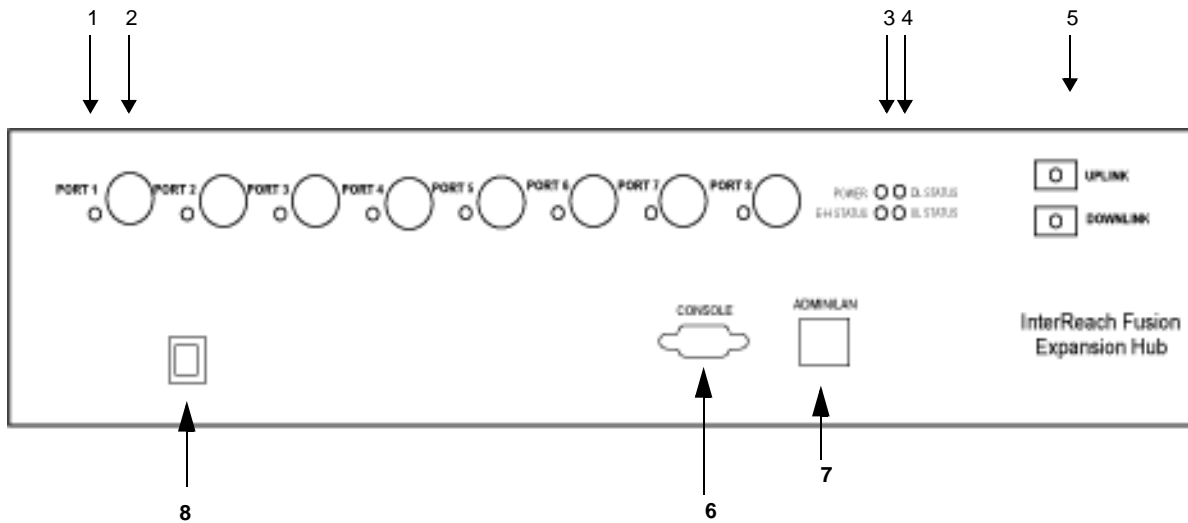
Figure 4-2 Expansion Hub Block Diagram





## 4.2 Expansion Hub Front Panel

Figure 4-3 Expansion Hub Front Panel



1. One port LED per type F connector port for link status and downstream RAU status (8 pair total).
2. Eight CATV cable, type F connectors (labeled **PORT 1, 2, 3, 4, 5, 6, 7, 8**)
3. One pair of unit status LEDs
  - One LED for unit power status (labeled **POWER**)
  - One LED for unit status (labeled **E-HUB STATUS**)
4. One set of fiber connection status LEDs
  - One LED for fiber downlink status (labeled **DL STATUS**)
  - One LED for fiber uplink status (labeled **UL STATUS**)
5. One fiber optic port which has two connectors
  - One standard female SC/APC connector for MMF/SMF output (labeled **UPLINK**)
  - One standard female SC/APC connector for MMF/SMF input (labeled **DOWNLINK**)
6. One 9-pin D-sub male connector for ADC factory testing (labeled **CONSOLE**)
7. One RJ-45 female connector for system communication and diagnostics using a PC/laptop with direct connect or using a LAN switch (labeled **ADMIN/LAN**)
8. Power Switch

### 4.2.1 75 Ohm Type F Connectors

The eight type F connectors on the Expansion Hub are for the CATV cables used to transmit and receive signals to and from RAUs. Use only 75 ohm type F connectors on the CATV cable.

The CATV cable also delivers DC electrical power to the RAUs. The Expansion Hub's DC voltage output is 54V DC nominal. A current limiting circuit protects the Hub if any port draws excessive power.

---

**NOTE:** For system performance, it is important to use only low loss solid copper center conductor CATV cable with quality type F connectors that use captive centerpin connectors. Refer to Appendix A for approved cables and connectors.

---

### 4.2.2 Manufacturing RS-232 Serial Connector

#### Console Port

This console port is only used by ADC manufacturing test purposes. **DO NOT CONNECT ANYTHING TO IT.**

#### Local Monitoring

Use a crossover Ethernet cable (PN-4069-ADB) to directly connect a laptop or PC to the RJ-45 female connector for local monitoring or configuring the Expansion Hub and associated RAUs using the AdminBrowser-EH resident software. The cable typically has a RJ-45 male connector on both ends. Refer to Appendix A.5 on page A-8 for the cable pinout and the AdminBrowser manual.

### 4.2.3 Optical Fiber Uplink/Downlink Connectors

The optical fiber uplink/downlink port transmits and receives optical signals between the Expansion Hub and the Main Hub using industry-standard SMF or MMF cable. The fiber port has two female SC/APC connectors:

- **Optical Fiber Uplink Connector**

This connector (labeled **UPLINK**) is used to transmit (output) uplink optical signals to the Main Hub.

- **Optical Fiber Downlink Connector**

This connector (labeled **DOWNLINK**) is used to receive (input) downlink optical signals from the Main Hub.



**CAUTION:** To avoid damaging the Expansion Hub's fiber connector ports, use only SC/APC fiber cable connectors. Additionally, use only

SC/APC fiber connectors throughout the fiber network, including fiber distribution panels. This is critical for ensuring system performance.

#### 4.2.4 LED Indicators

The unit's front panel LEDs indicate fault conditions and commanded or fault lockouts. The LEDs do not indicate warnings or whether the system test has been performed. Only use the LEDs to provide basic information or as a backup when you are not using AdminBrowser.

Upon power up, the Expansion Hub goes through a five-second test to check the LED lamps. During this time, the LEDs blink through the states shown in Table 4-2, letting you visually verify that the LED lamps and the firmware are functioning properly.

**NOTE:** Refer to Section 9 for troubleshooting using the LEDs.

#### Unit Status and DL/UL Status LEDs

The Expansion Hub unit status and DL/UL status LEDs can be in one of the states shown in Table 4-1. These LEDs can be:

- steady green
- steady red
- off

**Table 4-1 Expansion Hub Unit Status and DL/UL Status LED States**

	LED State	Indicates
<b>POWER</b> ● ● <b>DL STATUS</b> <b>EH STATUS</b> ● ● <b>UL STATUS</b>	Green / Green Green / Green	<ul style="list-style-type: none"> <li>• The Expansion Hub is connected to power and all power supplies are operating.</li> <li>• The Expansion Hub is not reporting a fault or lockout condition; but the system test may need to be performed or a warning condition could exist (use AdminManager to determine this).</li> <li>• Optical power received is above minimum (the Main Hub is connected) although the cable optical loss may be greater than recommended maximum.</li> <li>• Optical power transmitted (uplink laser) is normal and communications with the Main Hub are normal.</li> </ul>
<b>POWER</b> ● ● <b>DL STATUS</b> <b>EH STATUS</b> ● ● <b>UL STATUS</b>	Green / Green Red / Green	<ul style="list-style-type: none"> <li>• Optical power received is above minimum (the Main Hub is connected) although the cable optical loss may be greater than recommended maximum.</li> <li>• Optical power transmitted (uplink laser) is normal and communications with the Main Hub are normal.</li> <li>• The Expansion Hub is reporting a fault.</li> </ul>

Table 4-1 Expansion Hub Unit Status and DL/UL Status LED States (continued)

	LED State	Indicates
<b>POWER</b> ● ● <b>DL STATUS</b> <b>EH STATUS</b> ● ● <b>UL STATUS</b>	Green / Green Green / Green (60-ppm)	<ul style="list-style-type: none"> <li>Optical power received is above minimum (the Main Hub is connected) although the cable optical loss may be greater than recommended maximum.</li> <li>Optical power transmitted (uplink laser) is normal and communications with the Main Hub are normal.</li> <li>The Expansion Hub is reporting a commanded lockout.</li> </ul>
<b>POWER</b> ● ● <b>DL STATUS</b> <b>EH STATUS</b> ● ● <b>UL STATUS</b>	Green / Red Red / Green	<ul style="list-style-type: none"> <li>A fault condition was detected, optical power received is below minimum. (the Main Hub is not connected, is not powered, or the Main Hub's downlink laser has failed, or the downlink fiber is disconnected or damaged.)</li> </ul>
<b>POWER</b> ● ● <b>DL STATUS</b> <b>EH STATUS</b> ● ● <b>UL STATUS</b>	Green / Green Red / Red	<ul style="list-style-type: none"> <li>The Expansion Hub is reporting a fault condition.</li> <li>Optical power received is above minimum (Main Hub is connected) although the cable optical loss may be greater than recommended maximum.</li> <li>Optical power transmitted is below minimum (Expansion Hub uplink laser has failed; unable to communicate with Main Hub). <b>UL STATUS</b> LED state must be checked within the first 90 seconds after power on. If initially green, then red after 90 seconds, it means that there is no communication with the Main Hub. If red on power up, replace the Expansion Hub.</li> </ul>
<b>POWER</b> ● ● <b>DL STATUS</b> <b>EH STATUS</b> ● ● <b>UL STATUS</b>	Green / Red Red / Red	<ul style="list-style-type: none"> <li>Optical power received is below minimum (the Main Hub is not connected, is not powered, or the Main Hub's downlink laser has failed, or the downlink fiber is disconnected or damaged.)</li> <li>Optical power transmitted is below minimum (the Expansion Hub uplink laser has failed; is unable to communicate with the Main Hub). <b>UL STATUS</b> LED state must be checked within the first 90 seconds after power on. If initially green, then red after 90 seconds, it means that there is no communication with the Main Hub. If red on power up, the uplink laser has failed, replace the Expansion Hub.</li> </ul>
<b>POWER</b> ● ● <b>DL STATUS</b> <b>EH STATUS</b> ● ● <b>UL STATUS</b>	Green / Off Green / Off	<ul style="list-style-type: none"> <li>Expansion Hub is in factory test mode, return it to the factory.</li> </ul>
<b>POWER</b> ● ● <b>DL STATUS</b> <b>EH STATUS</b> ● ● <b>UL STATUS</b>	Red / Don't Care Red / Don't Care	<ul style="list-style-type: none"> <li>One or more power supplies are out of specification. The hub needs to be replaced.</li> </ul>
<b>POWER</b> ● ● <b>DL STATUS</b> <b>EH STATUS</b> ● ● <b>UL STATUS</b>	Green / Red Off / Off	<ul style="list-style-type: none"> <li>Expansion Hub failure. The Hub must be replaced.</li> </ul>

## RJ-45 Port LEDs

The Expansion Hub has a port LED, labeled **PORT**, for each of the eight 75 Ohm, Type F ports. The port LEDs can be in one of the states shown in Table 4-2. These LEDs can be:

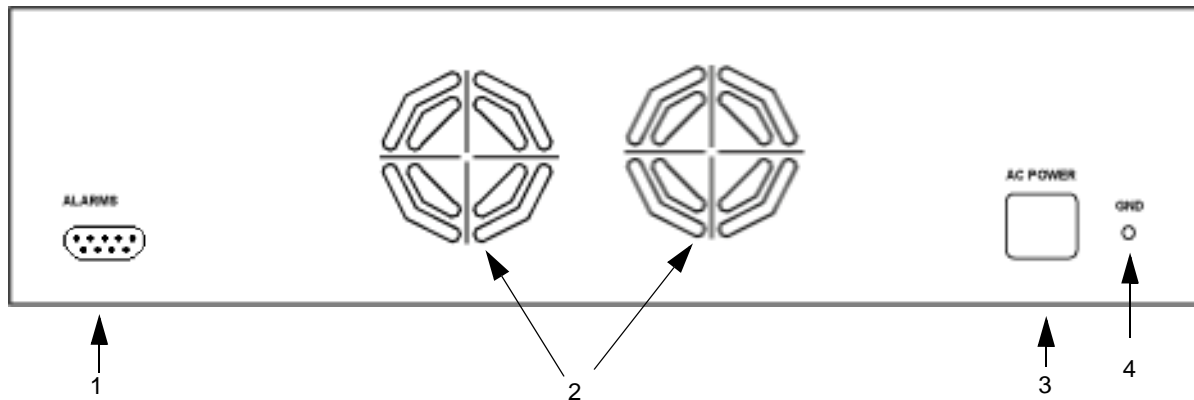
- off
- steady green
- steady red
- flashing red (60 pulses per minute [PPM])

**Table 4-2 Fusion Wideband Expansion Hub Port LED States**

	LED State	Indicates
<b>PORT</b> ○	Off	<ul style="list-style-type: none"> <li>• The RAU is not connected.</li> </ul>
<b>PORT</b> ●	Green	<ul style="list-style-type: none"> <li>• The RAU is connected.</li> <li>• No faults from the RAU.</li> </ul>
<b>PORT</b> ●	Red (60 PPM)	<ul style="list-style-type: none"> <li>• The RAU was disconnected.</li> <li>• The RAU is not communicating.</li> <li>• The RAU port power is tripped.</li> </ul>
<b>PORT</b> ●	Red (Steady)	<ul style="list-style-type: none"> <li>• The RAU is disconnected.</li> <li>• The RAU is reporting a fault.</li> </ul>
<b>PORT</b> ●	Green (60-ppm)	<ul style="list-style-type: none"> <li>• The RAU is disconnected.</li> <li>• The RAU is reporting a lockout condition.</li> </ul>

### 4.3 Expansion Hub Rear Panel

Figure 4-4 Expansion Hub Rear Panel



1. AC power cord connector
2. Two air exhaust vents
3. One 9-pin D-sub female connector for contact alarm monitoring (labeled **ALARMS**)
4. Ground lug for connecting unit to frame ground (labeled **GROUND**)

Table 4-3 9-pin D-sub Pin Connector Functions

Pin	Function
1	Alarm Sense Input (DC Ground)
2	Alarm Sense Input 3
3	Alarm Sense Input 2
4	N/C
5	N/C
6	DC Ground (common)
7	N/C
8	Alarm Sense Input 1
9	N/C

This interface can monitor three single external alarm contacts (Alarm Sense Input 1  
This interface monitors the output contact closures from a Universal Power Supply (UPS). Verify the output contact closure state (normally closed or normally open) of the UPS, and set the appropriate contact definition using AdminBrowser.

- Faults are service impacting.

- Warnings indicate a possible service impact.
- Status messages are generally not service impacting.

---

## 4.4 Faults, Warnings, and Status Messages

Both fault and warning conditions of the Expansion Hub and attached RAUs are reported to the Main Hub. Only faults are indicated by LEDs.

For more information, refer to Appendix C, “Faults, Warnings, Status Tables,” on page C-1.

---

**NOTE:** You can select what type of events AdminBrowser displays. Refer to Section 3.5.2 View Preference on 3-12.

---

## 4.5 Expansion Hub Specifications

**Table 4-4 Expansion Hub Specifications**

Specification	Description
Enclosure Dimensions (H × W × D)	89 mm x 438 mm x 381 mm (3.5 in. x 17.25 in. x 15 in.) 2U
Weight	< 6.6 kg (< 14.5 lb.)
Operating Temperature	0° to +45°C (+32° to +113°F)
Non-operating Temperature	-20° to +85°C (-4° to +185°F)
Operating Humidity, non-condensing	5% to 95%
CATV Connectors <sup>a</sup>	8 F, female (CATV - 75 Ohm)
Fiber Connectors <sup>b</sup>	1 Pair, SC/APC
LED Alarm and Status Indicators	Unit Status (1 pair): <ul style="list-style-type: none"> <li>• Power</li> <li>• E-Hub Status</li> </ul> Fiber Link Status (1 pair): <ul style="list-style-type: none"> <li>• DL Status</li> <li>• UL Status</li> </ul> Port Status (1 pair per CATV port): <ul style="list-style-type: none"> <li>• Link/RAU</li> </ul>
External Alarm Connector (contact sense monitor)	1 9-pin D-sub, female
AC Power (Volts) (47–63 Hz)	Rating: 100/240V AC, 6A, 50-60 Hz Operating Range: 90-132V AC/170-250V AC auto-ranging
Power Consumption (W)	4 RAUs: 275 typical, 335 max. 8 RAUs: 475 typical, 585 max.
MTBF	54,539 hours

a. It is important that you use only recommended CATV 75 Ohm cable with quality F connectors.

b. It is critical to system performance that only SC/APC fiber connectors are used throughout the fiber network, including fiber distribution panels.



# Remote Access Unit

---

This section contains the following subsections:

- Section 5.1 RAU Overview . . . . . 5-1
- Section 5.2 Remote Access Unit Connectors . . . . . 5-5
- Section 5.3 RAU LED Indicators . . . . . 5-5
- Section 5.4 Faults and Warnings . . . . . 5-6
- Section 5.5 Remote Access Unit Specifications . . . . . 5-7

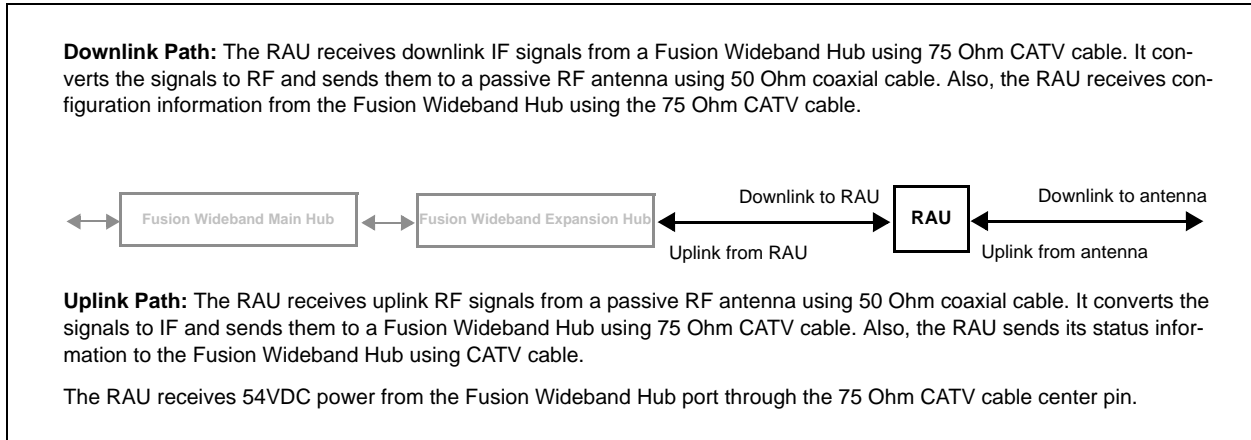
---

## 5.1 RAU Overview

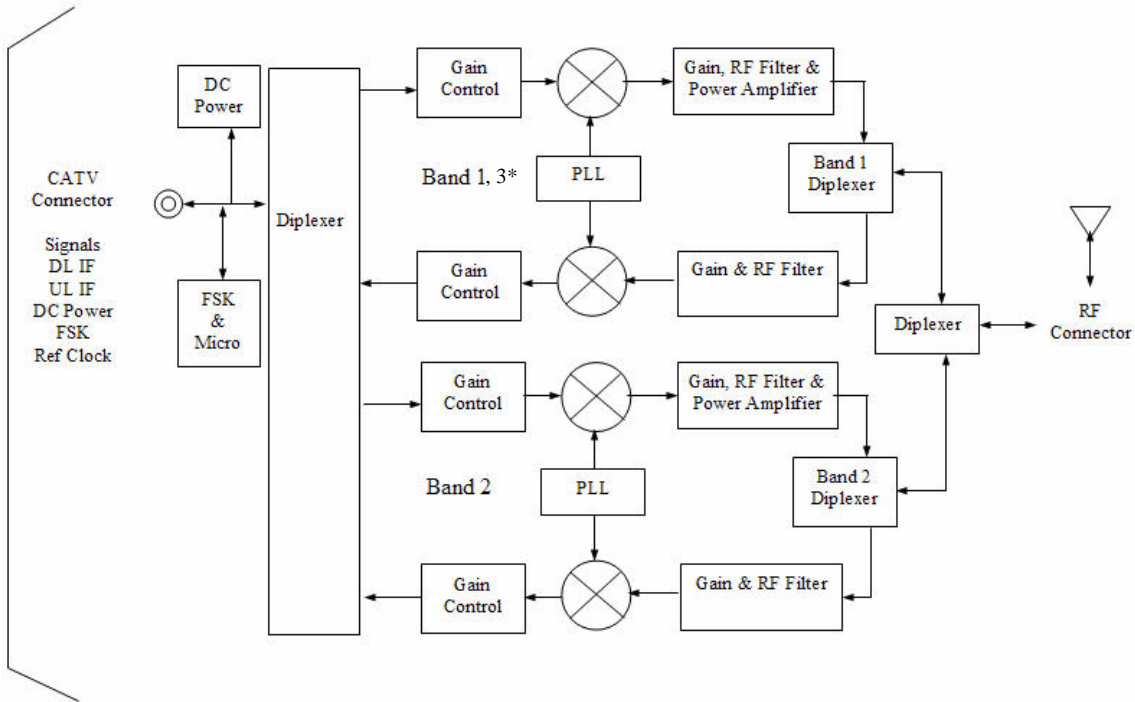
The Remote Access Unit (RAU) is an active transceiver that connects to an Expansion Hub using industry-standard CATV cable, which delivers RF signals, configuration information, and electrical power to the RAU.

An RAU passes converted IF to RF (Downlink) and converted RF to IF (Uplink) signals between an Expansion Hub and an attached passive antenna where the signals are transmitted to wireless devices as shown in Figure 5-1.

**Figure 5-1 Remote Access Unit in a Fusion Wideband System**



**Figure 5-2 Remote Access Unit Block Diagram (Multiband)**



\* For FSN-W2-808519-1 RAU when Band 3 is active.

The Fusion Wideband RAUs are manufactured to a specific set of bands: one 60 MHz Band 1 (split into two sub-bands 1A and 1B for the FSN-W2-808519-1 RAU), and one 75 MHz Band 2. Table 5-1 lists the Fusion Wideband RAUs, the Fusion Wideband Band, and the frequency bands they cover.

**Table 5-1 Frequency Bands Covered by Fusion Wideband RAUs**

Fusion Wideband RAU	Part Number	Fusion Wideband Band	RF Passband		MAIN HUB/RAU Band	RAU Bandwidth
			Downlink (MHz)	Uplink (MHz)		
2100/1800	FSN-W1-2118-1	2100	2110-2170	1920-1980	1	60 MHz
		1800	1805-1880	1710-1785	2	75 MHz
2100 High Power (single-band RAU)	FSN-W1-21HP-1	2100	2110-2170	1920-1980	1	60 MHz
800/850/1900	FSN-W2-808519-1	800	851-869	806-824	1 (sub-band 1A)	18 MHz
		850	869-894	824-849	3 (sub-band 1B)	25 MHz
		1900 (A-F)	1930-1990	1850-1910	2	60 MHz
1900/AWS	FSN-W1-1921-1	1900 (A-F)	1930-1990	1850-1910	1	60 MHz
		AWS	2110-2155	1710-1755	2	45 MHz
2500/2500	FSN-2500-2-WMAX	2500	2496-2690	2496-2690	1	30 MHz
		2500	2496-2690	2496-2690	2	30 MHz

**Table 5-2 System Gain (Loss) Relative to CATV Cable Length**

Cable Type	Comm-Scope Part Number	Plenum Rated	Solid Copper Conductor	Copper Clad Conductor	Zero-loss RF Maximum Length (meters)	Distance RF is 10dB Below Input RF (meters)
<b>RG-59</b>						
	2065V	Yes	X		130	180
	2022V	Yes		X	100	100*
	5572R	No		X	95	95*
	5565	No	X		130	180
<b>RG-6</b>						
	2279V	Yes	X		140	190
	2275V	Yes		X	140	150*
	5726	No		X	140	140*
	5765	No	X		140	190
<b>RG-11</b>						
	2293K	Yes	X		235	320
	2285K	Yes		X	235	300*
	5913	No		X	235	300*

\* Exceeding the distance of copper-clad cable will result in the attached RAU becoming non-functional. If the distance of a cable run is at its maximum and is of concern, ADC recommends the use of solid copper cable to ensure successful operation.

---

## 5.2 Remote Access Unit Connectors

### 5.2.1 50 Ohm Type-N Connector

The RAU has one female type-N connector. The connector is a duplexed RF input/output port that connects to a standard 50Ω passive antenna using coaxial cable.

### 5.2.2 75 Ohm Type-F Connector

The RAU has one type-F female connector that connects it to a Fusion Wideband Hub using CATV 75 Ohm cable. Use RG-59, 6, or 11 solid copper center conductor cables.

---

**NOTE:** For system performance, it is important that you use only low loss, solid copper center conductor CATV cable with quality F connectors that use captive centerpin conductors. Refer to Appendix A for specific information.

---

---

## 5.3 RAU LED Indicators

Upon power up, the RAU goes through a two-second test to check the LED lamps. During this time, the LEDs blink green/green red/red, letting you visually verify that the LED lamps and the firmware are functioning properly.

---

**NOTE:** Refer to Section 9 for troubleshooting using the LEDs.

---

### Status LEDs

The RAU status LEDs can be in one of the states shown in Table 5-3. These LEDs can be:

- off
- steady green
- steady red

There is no off state when the unit's power is on.

**Table 5-3 Remote Access Unit LED States**

	LED State	Indicates
LINK ○ ALARM ○	Off Off	<ul style="list-style-type: none"> <li>The RAU is not receiving DC power.</li> </ul>
LINK ● ALARM ●	Green Green	<ul style="list-style-type: none"> <li>The RAU is powered and is not indicating a fault condition. Communication with the Fusion Wideband Hub is normal; however, the system test may need to be performed or a warning condition may exist (use AdminBrowser to determine this).</li> </ul>
LINK ● ALARM ●	Green Red	<ul style="list-style-type: none"> <li>The RAU is indicating a fault or lockout condition, but communication with the Fusion Wideband Hub is normal.</li> </ul>
LINK ● ALARM ●	Red Red	<ul style="list-style-type: none"> <li>The RAU is reporting a fault and is not able to communicate with the Fusion Wideband Hub</li> </ul>
LINK ● ALARM ●	Green (60-ppm) Green (60-ppm)	<ul style="list-style-type: none"> <li>The RAU is reporting a lockout condition, but communication with the Fusion Wideband Hub is normal.</li> </ul>

## 5.4 Faults and Warnings

Both fault and warning conditions are reported to the Fusion Wideband Hub where they are stored. Only faults are indicated by the faceplate LEDs.

For more information, refer to Appendix C.

## 5.5 Remote Access Unit Specifications

**Table 5-4 Remote Access Unit Specifications**

Specification	Description
Dimensions (H × W × D)	54 mm × 286 mm × 281 mm (2.13 in. × 11.25 in. × 11.13 in.)
Weight	< 2.1 kg (< 4.6 lb.)
Operating Temperature	−25° to +45°C (−13° to +113°F)
Non-operating Temperature	−25° to +85°C (−13° to +185°F)
Operating Humidity, non-condensing	5% to 95%
RF Connectors	One Type-F, female (CATV - 75 ohms) One Type-N, female <sup>a</sup> (coaxial 50 ohms)
LED Alarm and Status Indicators	Unit Status (1 pair): • Link • Alarm
Maximum Heat Dissipation (W)	50 typical, 64 max (from the Hub)
MTBF	202,684 hours

a. Two type N female connectors for FSN-W2-808519-1, FSN-W1-1921-1, and FSN-2500-2-WMAX RAUs.

**NOTE:** For system performance, it is important that you use only low loss, solid copper center conductor CATV cable with quality F connectors that use captive centerpin conductors. Refer to Appendix A for more information.

---

**Remote Access Unit Specifications**

---



# Designing a Fusion Wideband Solution

---

This section contains the following subsections:

- Section 6.1 Overview . . . . . 6-1
- Section 6.2 Downlink RSSI Design Goal . . . . . 6-3
- Section 6.3 Maximum Output Power per Carrier . . . . . 6-4
- Section 6.4 System Gain . . . . . 6-12
- Section 6.5 Estimating RF Coverage . . . . . 6-14
- Section 6.6 Link Budget Analysis . . . . . 6-22
- Section 6.7 Optical Power Budget . . . . . 6-34
- Section 6.8 Connecting a Main Hub to a Base Station . . . . . 6-35

---

## 6.1 Overview

Designing a Fusion Wideband solution is a matter of determining coverage and capacity needs. This requires the following steps:

1. **Determine the wireless service provider’s requirements: Refer to Section 6.2, “Downlink RSSI Design Goal,” on page 6-3.**

The following information is typically provided by the service provider:

- Frequency (for example, 1900 MHz)
- Band (for example, “A-F” band in the PCS spectrum)
- Protocol (for example, CDMA, GSM, 1xRTT, GPRS, and so on)
- Number of sectors and peak capacity per sector (translates to the number of RF carriers that the system will have to transmit)
- Downlink RSSI design goal (RSSI, received signal strength at the wireless handset, for example, -85 dBm)

The design goal is always a stronger signal than the mobile phone needs. It includes inherent factors which affect performance.

- RF source (base station or bidirectional amplifier or repeater), type of equipment if possible.

**2. Determine the downlink power per carrier from the RF source through the DAS: Refer to Section 6.3, “Maximum Output Power per Carrier,” on page 6-4.**

The maximum power per carrier is a function of modulation type, the number of RF carriers, signal quality issues, regulatory emissions requirements, and Fusion Wideband’s RF performance. Power per carrier decreases as the number of carriers increases.

**3. Develop an RF link budget: Refer to Section 6.5, “Estimating RF Coverage,” on page 6-14.**

Knowing both the power per carrier and RSSI design goal, you can develop an RF downlink link budget which estimates the allowable path loss from an RAU’s antenna to the wireless handset.

$$\text{allowable path loss} = \text{power per carrier} + \text{antenna gain} - \text{design goal}$$

Satisfactory performance can be expected as long as path loss is below this level.

**4. Determine the in-building environment: Refer to Section 6.5, “Estimating RF Coverage,” on page 6-14.**

- Determine which areas of the building require coverage (entire building, public areas, parking levels, and so on.)
- Obtain floor plans to determine floor space of building and the wall layout of the proposed areas to be covered. Floor plans are also useful when you are selecting antenna locations.
- If possible, determine the building’s construction materials (sheetrock, metal, concrete, and so on.)
- Determine the type of environment:
  - Open layout (for example, a convention center)
  - Dense, close walls (for example, a hospital)
  - Mixed use (for example, an office building with hard wall offices and cubicles)

**5. Determine the appropriate estimated path loss slope that corresponds to the type of building and its layout, and estimate the coverage distance for each RAU: Refer to Section 6.5, “Estimating RF Coverage,” on page 6-14.**

Use the path loss slope (PLS), which gives a value to the RF propagation characteristics within the building, to convert the RF link budget into an estimate of the coverage distance per antenna. This helps establish the quantities of Fusion Wideband equipment you need. The actual path loss slope that corresponds to the specific RF environment inside the building can also be determined empirically by performing an RF site-survey of the building. This involves transmitting a cali-

brated tone for a fixed antenna and making measurements with a mobile antenna throughout the area surrounding the transmitter.

**6. Determine the items required to connect to the base station: Refer to Section 6.8, “Connecting a Main Hub to a Base Station,” on page 6-35.**

Once you know the quantities of Fusion Wideband equipment to be used, you can determine the accessories (combiners/dividers, surge suppressors, repeaters, attenuators, circulators, and so on.) required to connect the system to the base station.

The individual elements that must be considered in designing a Fusion Wideband solution are explained in the following sections.

**NOTE:** Access the ADC Customer Portal at [adc.com](http://adc.com) for on-line dimensioning and design tools.

## 6.2 Downlink RSSI Design Goal

Wireless service providers typically provide a minimum downlink signal level and an associated confidence factor when specifying coverage requirements. These two figures of merit are a function of wireless handset sensitivity and margins for fading and body loss. Wireless handset sensitivity is the weakest signal that the handset can process reliably and is a combination of the thermal noise in the channel, noise figure of the handset receiver front end and minimum required SNR. Fade margins for multipath fading (fast or small-scale) and log-normal shadow fading (slow or large-scale) are determined by the desired confidence factor, and other factors. Downlink RSSI design goal calculations for the GSM protocol are shown below for a 95% area coverage confidence factor.

Noise Power	-121 dBm
<small>10 Log (KT)+10 Log (200 KHz); K=1.38X10<sup>-23</sup>, T=300 degrees Kelvin</small>	
Wireless Handset Noise Figure	8 dB
Required SNR	9 dB
Multipath Fade Margin	6 dB
<small>95% Reliability for Rician K=6 dB</small>	
Log-normal Fade Margin	10 dB
<small>95% Area/87% Edge Reliability for 35 dB PLS and 9 dB Sigma</small>	
Body Attenuation	+ 3 dB
Downlink RSSI Design Goal (P <sub>DesignGoal</sub> )	-85 dBm
<small>Signal level received by wireless handset at edge of coverage area</small>	

Downlink design goals on the order of  $-85$  dBm are typical for protocols, such as GSM. Wireless service providers may choose a higher level to ensure that in-building signal dominates any macro signal that may be leaking into the building.

---

### 6.3 Maximum Output Power per Carrier

The following tables show the recommended maximum power per carrier out of the RAU 50 Ohm Type-N connector for different frequencies, protocols, and numbers of carriers. These maximum levels are dictated by RF signal quality and regulatory emissions issues. In general, as the number of RF carrier increases, the maximum power per carrier decreases. If these levels are exceeded, signal quality will be degraded and/or regulator requirements will be violated. The maximum input power to the Hub is determined by subtracting the system gain from the maximum output power of the RAU. System gain is software selectable from 0 dB to 15 dB in 1 dB steps. Additionally, both the uplink and downlink gain of each RAU can be attenuated 0 or 10 dB.

When connecting a Hub to a base station or repeater, attenuation on the downlink is typically required to avoid exceeding Fusion Wideband's maximum output power recommendations.



**WARNING:** Exceeding the maximum input power may cause permanent damage to the Hub. Do not exceed the maximum composite input power of 1W (+30 dBm) to the Hub at any time.

---

**NOTE:** These specifications are for downlink power at the RAU output (excluding antenna).

---

**6.3.1 800 MHz SMR**

**Table 6-1 Power per Carrier**

No. of Carriers	Power per Carrier (dBm) - 800MHz			
	iDEN	Analog FM	APCO 25 CQPSK	APCO 25 C4FM
1	16.6	24.0	21.0	24.0
2	13.0	19.0	16.0	18.5
3	10.5	15.5	13.5	15.0
4	9.0	12.5	11.5	12.5
5	8.0	11.0	10.0	10.5
6	7.0	9.5	8.5	9.0
7	6.0	8.5	8.0	8.0
8	5.5	7.5	7.0	7.5
9	5.0	7.0	6.5	6.5
10	4.5	6.0	6.0	6.0
11	4.0			
12	3.5			
13	3.0			
14	3.0			
15	2.5			
16	2.0			

Note: Operation at or above these output power levels may prevent Fusion Wideband from meeting RF performance specifications or FCC Part 15 and EN55022 emissions requirements.

### 6.3.2 850 MHz Cellular

Table 6-2 Cellular Power per Carrier

No. of Carriers	Power per Carrier (dBm)					WCDMA
	AMPS	TDMA	GSM	EDGE	CDMA	
1	16.5	16.5	16.5	16.5	16.0	15.0
2	16.5	16.5	13.5	13.5	13.0	11.0
3	16.5	15.0	11.5	11.5	11.0	8.0
4	13.5	13.0	10.0	10.0	10.0	6.5
5	12.0	11.5	9.0	9.0	9.0	5.0
6	10.5	10.5	8.5	8.5	8.0	
7	9.5	9.5	8.0	8.0	7.5	
8	8.5	8.5	7.5	7.5	7.0	
9	8.0	8.0	7.0	7.0		
10	7.0	7.5	6.5	6.5		
11	7.0	7.0	6.5	6.5		
12	6.5	6.5	6.0	6.0		
13	6.0	6.5	6.5	5.5		
14	5.5	6.0	5.5	5.5		
15	5.5	5.5	5.0	5.0		
16	5.0	5.5	5.0	5.0		
20	4.0	4.5	4.5	4.0		
30	2.0	2.5	3.0	2.0		

Note: Operation at or above these output power levels may prevent Fusion Wideband from meeting RF performance specifications or FCC Part 15 and EN55022 emissions requirements.

### 6.3.3 1800 MHz DCS

Table 6-3 DCS Power per Carrier

No. of Carriers	Power per Carrier (dBm)	
	GSM	EDGE
1	16.5	16.5
2	14.5	14.5
3	12.5	12.5
4	11.5	11.5
5	10.5	10.5
6	9.5	9.5
7	9.0	9.0
8	8.5	8.0
9	8.0	7.5
10	7.5	7.0
11	7.0	6.5
12	6.5	6.0
13	6.5	6.0
14	6.0	5.5
15	5.5	5.0
16	5.5	5.0
20	4.5	4.0
30	2.5	2.0

**Note:** Operation at or above these output power levels may prevent Fusion Wideband from meeting RF performance specifications or FCC Part 15 and EN55022 emissions requirements.

### 6.3.4 1900 MHz PCS

Table 6-4 PCS Power per Carrier

No. of Carriers	Power per Carrier (dBm)				
	TDMA	GSM	EDGE	CDMA	WCDMA
1	16.5	16.5	16.5	16.0	15.0
2	16.5	15.5	15.5	13.0	11.0
3	15.0	13.5	13.5	11.0	8.0
4	13.0	12.0	12.0	10.0	6.5
5	11.5	11.0	10.5	9.0	5.0
6	10.5	10.5	9.5	8.0	
7	9.5	10.0	9.0	7.5	
8	8.5	9.0	8.0	7.0	
9	8.0	8.5	7.5		
10	7.5	8.0	7.0		
11	7.0	7.5	6.5		
12	6.5	7.0	6.0		
13	6.5	6.5	6.0		
14	6.0	6.5	5.5		
15	5.5	6.0	5.0		
16	5.5	5.5	5.0		
20	4.5	4.5	4.0		
30	2.5	3.0	2.0		

Note: Operation at or above these output power levels may prevent Fusion Wideband from meeting RF performance specifications or FCC Part 15 and EN55022 emissions requirements.



**6.3.5 2100 MHz AWS**

**Table 6-5 AWS Power per Carrier**

No. of Carriers	Power per Carrier (dBm)				
	TDMA	GSM	EDGE	CDMA	WCDMA
1	16.5	16.5	16.5	16.0	15.0
2	16.5	15.5	15.5	13.0	11.0
3	15.0	13.5	13.5	11.0	8.0
4	13.0	12.0	12.0	10.0	6.5
5	11.5	11.0	10.5	9.0	5.0
6	10.5	10.5	9.5	8.0	
7	9.5	10.0	9.0	7.5	
8	8.5	9.0	8.0	7.0	
9	8.0	8.5	7.5		
10	7.5	8.0	7.0		
11	7.0	7.5	6.5		
12	6.5	7.0	6.0		
13	6.5	6.5	6.0		
14	6.0	6.5	5.5		
15	5.5	6.0	5.0		
16	5.5	5.5	5.0		
20	4.5	4.5	4.0		
30	2.5	3.0	2.0		

**Note:** Operation at or above these output power levels may prevent Fusion Wideband from meeting RF performance specifications or FCC Part 15 and EN55022 emissions requirements.

### 6.3.6 2.1 GHz UMTS

**Table 6-6 UMTS Power per Carrier**

No. of Carriers	Power per Carrier (dBm) WCDMA
1	15.0
2	11.0
3	8.0
4	6.5
5	5.0
6	4.0
7	3.0

**Note:** Measurements were taken with no baseband clipping.

**Note:** Operation at or above these output power levels may prevent Fusion Wideband from meeting RF performance specifications or FCC Part 15 and EN55022 emissions requirements.

### 6.3.7 2.1 GHz UMTS High Power

**Table 6-7 UMTS Power per Carrier**

No. of Carriers	Power per Carrier (dBm) WCDMA
1	22.0
2	18.0
3	15.0
4	13.5
5	12.0
6	11.0
7	10.0

**Note:** Measurements taken with no baseband clipping.

**Note:** Operation at or above these output power levels may prevent Fusion Wideband from meeting RF performance specifications or FCC Part 15 and EN55022 emissions requirements.

### 6.3.8 2500 MHz WiMAX

**Table 6-8 WiMAX Power per Carrier**

No. of Carriers	Power per Carrier (dBm) WiMAX
1	20.0

**Note:** Measurements taken with no baseband clipping.

**Note:** Operation at or above these output power levels may prevent Fusion Wideband from meeting RF performance specifications or FCC Part 15 and EN55022 emissions requirements.

## Designing for Capacity Growth

Fusion Wideband systems are deployed to enhance in-building coverage and/or to off-load capacity from a macro cell site. In many instances, subscriber usage increases with time and the wireless provider responds by increasing the load on the installed Fusion Wideband system. For example, the initial deployment might only require two RF carriers, but four RF carriers may be needed in the future based on capacity growth forecasts. There are two options for dealing with this scenario:

1. Design the initial coverage with a maximum power per carrier for four RF carriers. This will likely result in additional RAUs.
2. Design the initial coverage for two RF carriers, but reserve RAU ports on the Hub for future use. These ports can be used to fill potential coverage holes once the power per carrier is lowered to accommodate the two additional carriers.

## **6.4 System Gain**

The system gain of the Fusion Wideband defaults to 0 dB or can be set up to 15 dB in 1 dB increments. In addition, uplink and downlink gains of each RAU can be independently attenuated by 0 or 10 dB using AdminBrowser.

The recommended maximum lengths of CATV cable are as follows:

- For RG-59 cable 130 meters for CommScope PN 2065V.
- For RG-6 cable 140 meters for CommScope PN 2279V.
- For RG-11 cable 235 meters for CommScope PN 2293K.

If the maximum distance is not required, then copper-clad over steel center-conductor cable may be use to reduce cable costs.

If the CATV cable is longer than the recommended distance per cable type, the gain of the system will decrease, as shown in Table 6-9.

Table 6-9 System Gain (Loss) Relative to CATV Cable Length

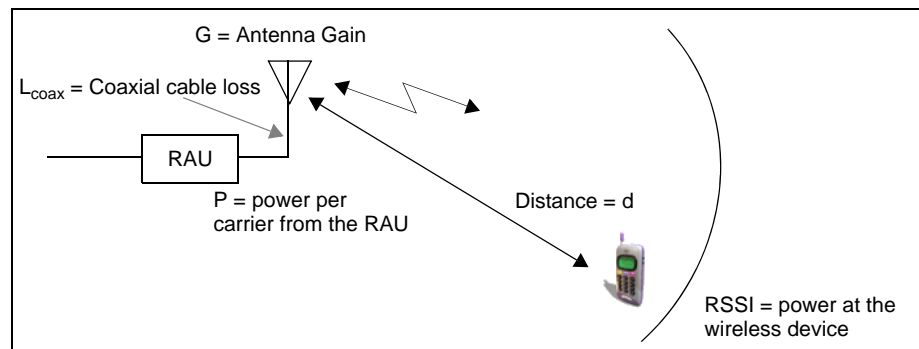
Cable Type	Comm-Scope Part Number	Plenum Rated	Solid Copper Conductor	Copper Clad Conductor	Zero-loss RF Maximum Length (meters)	Distance Where RF is 10dB Below Input RF (meters)
<b>RG-59</b>						
	2065V	Yes	X		130	180
	2022V	Yes		X	100	100*
	5572R	No		X	95	95*
	5565	No	X		130	180
<b>RG-6</b>						
	2279V	Yes	X		140	190
	2275V	Yes		X	140	150*
	5726	No		X	140	140*
	5765	No	X		140	190
<b>RG-11</b>						
	2293K	Yes	X		235	320
	2285K	Yes		X	235	300*
	5913	No		X	235	300*

\* Exceeding the distance of copper-clad cable will result in the attached RAU becoming non-functional. If the distance of a cable run is at its maximum and is of concern, ADC recommends the use of solid copper cable to ensure successful operation.

## 6.5 Estimating RF Coverage

The maximum output power per carrier (based on the number and type of RF carriers being transmitted) and the minimum acceptable received power at the wireless device (that is, the RSSI design goal) essentially establish the RF downlink budget and, consequently, the maximum allowable path loss (APL) between the RAU's antenna and the wireless device. Since in-building systems, such as the Fusion Wideband, are generally downlink-limited, this approach is applicable in the majority of deployments.

**Figure 6-1 Determining APL between the Antenna and the Wireless Device**



$$APL = (P - L_{coax} + G) - RSSI \quad (1)$$

where:

- APL = the maximum allowable path loss in dB
- P = the power per carrier transmitted by the RAU in dBm
- L<sub>coax</sub> = the coaxial cable loss between the RAU and passive antenna in dB
- G = the gain of the passive antenna in dBi

Coaxial cable is used to connect the RAU to an antenna. Table 6-10 lists coaxial cable loss for various cable lengths.

**Table 6-10 Coaxial Cable Losses (L<sub>coax</sub>)**

Length of Cable (.195 in. diameter)	Loss at 850 MHz (dB)	Loss at 1900 MHz (dB)
0.9 m (3 ft)	0.6	0.8
1.8 m (6 ft)	1.0	1.5
3.0 m (10 ft)	1.5	2.3

You can calculate the distance, d, corresponding to the maximum allowable path loss using equations introduced in the following sections.

### 6.5.1 Path Loss Equation

In-building path loss obeys the distance power law<sup>1</sup> in equation (2):

$$PL = 20\log_{10}(4\pi d_0 f/c) + 10n\log_{10}(d/d_0) + X_s \quad (2)$$

where:

- PL is the path loss at a distance, d, from the antenna
- d = the distance expressed in meters
- d<sub>0</sub> = free-space path loss distance in meters
- f = the operating frequency in Hertz.
- c = the speed of light in a vacuum (3.0 × 10<sup>8</sup> m/sec).
- n = the path loss exponent and depends on the building “clutter” and frequency of operation
- X<sub>s</sub> = a normal random variable that depends on partition material and geometries inside the building and is accounted for by the log-normal fade margin used in the downlink RSSI design goal calculation

As a reference, Table 6-11 provides estimates of signal loss for some RF barriers<sup>1</sup>.

**Table 6-11 Average Signal Loss of Common Building Materials**

Partition Type	Loss (dB)	Frequency (MHz)
Metal wall	26	815
Aluminum siding	20	815
Foil insulation	4	815
Cubicle walls	1.4	900
Concrete block wall	13	1300
Concrete floor	10	1300
Sheetrock	1 to 2	1300
Light machinery	3	1300
General machinery	7	1300
Heavy machinery	11	1300
Equipment racks	7	1300
Assembly line	6	1300
Ceiling duct	5	1300
Metal stairs	5	1300

1. Rappaport, Theodore S. *Wireless Communications, Principles, and Practice*. Prentice Hall PTR, 1996.

### 6.5.2 RAU Coverage Distance

Use equations (1) and (2), on pages 6-14 and 6-15, respectively, to estimate the distance from the antenna to where the RF signal decreases to the minimum acceptable level at the wireless device.

With  $d_0$  set to one meter and path loss slope (PLS) defined as  $10n$ , Equation (2) can be simplified to:

$$PL(d) = 20\log_{10}(4\pi f/c) + PLS \cdot \log_{10}(d) \quad (3)$$

Table 6-12 gives the value of the first term of Equation (3) (that is.,  $(20\log_{10}(4\pi f/c))$ ) for various frequency bands.

**Table 6-12 Frequency Bands and the Value of the First Term in Equation (3)**

Frequency	Band (MHz)		Mid-Band Frequency (MHz)	$20\log_{10}(4\pi f/c)$
	Uplink	Downlink		
800 MHz SMR	806-824	851-869	838	30.9
850 MHz Cellular	824-849	869-894	859	31.1
1800 MHz DCS	1710-1785	1805-1880	1795	37.5
1900 MHz PCS	1850-1910	1930-1990	1920	38.1
2.1 GHz UMTS	1920-1980	2110-2170	2045	38.7
1.7/2.1 GHz AWS	1710-1755	2110-2155	2132.5 <sup>a</sup>	39.0
2.5 GHz WiMAX	2496-2690	2496-2690	2595	40.7

a. Due to the wide frequency spread between the Uplink and Downlink bands, the mid-band frequency of the Downlink band was chosen for 1.7/2.1 GHz AWS.

Table 6-13 shows estimated PLS for various environments that have different “clutter” (that is, objects that attenuate the RF signals, such as walls, partitions, stairwells, equipment racks, and so.).

**Table 6-13 Estimated Path Loss Slope for Different In-Building Environments**

Environment Type	Example	PLS for 850/900 MHz	PLS for 1800/1900/2100/2500 MHz
<b>Open Environment</b> very few RF obstructions	Parking Garage, Convention Center	33.7	30.1
<b>Moderately Open Environment</b> low-to-medium amount of RF obstructions	Warehouse, Airport, Manufacturing	35	32
<b>Mildly Dense Environment</b> medium-to-high amount of RF obstructions	Retail, Office Space with approximately 80% cubicles and 20% hard walled offices	36.1	33.1



**Table 6-13 Estimated Path Loss Slope for Different In-Building Environments**

Environment Type	Example	PLS for 850/900 MHz	PLS for 1800/1900/2100/2500 MHz
<b>Moderately Dense Environment</b> medium-to-high amount of RF obstructions	Office Space with approximately 50% cubicles and 50% hard walled offices	37.6	34.8
<b>Dense Environment</b> large amount of RF obstructions	Hospital, Office Space with approximately 20% cubicles and 80% hard walled offices	39.4	38.1

By setting the path loss to the maximum allowable level (PL = APL), equation (3) can be used to estimate the maximum coverage distance of an antenna connected to an RAU, for a given frequency and type of in-building environment.

$$d = 10^{((APL - 20\log_{10}(4\pi f/c))/PLS)} \tag{4}$$

For reference, Tables 6-15 through 6-20 show the distance covered by an antenna for various in-building environments. The following assumptions were made:

- Path loss Equation (4)
- 6 dBm output per carrier at the RAU output
- 3 dBi antenna gain
- RSSI design goal = -85 dBm (typical for narrowband protocols, but not for spread-spectrum protocols)

**Table 6-14 Approximate Radiated Distance from Antenna for 800 MHz SMR Applications**

Environment Type	Distance from Antenna	
	Meters	Feet
Open Environment	75	244
Moderately Open Environment	64	208
Mildly Dense Environment	56	184
Moderately Dense Environment	48	156
Dense Environment	40	131

**Table 6-15 Approximate Radiated Distance from Antenna for 850 MHz Cellular Applications**

Environment Type	Distance from Antenna	
	Meters	Feet
Open Environment	73	241
Moderately Open Environment	63	205

**Table 6-15 Approximate Radiated Distance from Antenna for 850 MHz Cellular Applications**

<b>Environment Type</b>	<b>Distance from Antenna</b>	
	<b>Meters</b>	<b>Feet</b>
Mildly Dense Environment	55	181
Moderately Dense Environment	47	154
Dense Environment	39	129

**Table 6-16 Approximate Radiated Distance from Antenna for 1800 MHz DCS Applications**

<b>Facility</b>	<b>Distance from Antenna</b>	
	<b>Meters</b>	<b>Feet</b>
Open Environment	75	246
Moderately Open Environment	58	191
Mildly Dense Environment	50	166
Moderately Dense Environment	42	137
Dense Environment	30	100

**Table 6-17 Approximate Radiated Distance from Antenna for 1900 MHz PCS Applications**

<b>Facility</b>	<b>Distance from Antenna</b>	
	<b>Meters</b>	<b>Feet</b>
Open Environment	72	236
Moderately Open Environment	56	183
Mildly Dense Environment	49	160
Moderately Dense Environment	40	132
Dense Environment	29	96

**Table 6-18 Approximate Radiated Distance from Antenna for 2.1 GHz UMTS Applications**

Facility	Distance from Antenna	
	Meters	Feet
Open Environment	69	226
Moderately Open Environment	54	176
Mildly Dense Environment	47	154
Moderately Dense Environment	39	128
Dense Environment	28	93

**Table 6-19 Approximate Radiated Distance from Antenna for 1.7/2.1 GHz AWS Applications**

Facility	Distance from Antenna	
	Meters	Feet
Open Environment	67	220
Moderately Open Environment	52	172
Mildly Dense Environment	46	150
Moderately Dense Environment	38	125
Dense Environment	28	91

**Table 6-20 Approximate Radiated Distance from Antenna for 2.5 GHz WiMAX Applications**

Facility	Distance from Antenna	
	Meters	Feet
Open Environment	59	194
Moderately Open Environment	47	152
Mildly Dense Environment	41	134
Moderately Dense Environment	35	112
Dense Environment	25	83

### 6.5.3 Examples of Design Estimates

#### Example Design Estimate for an 1900 MHz CDMA Application

**1. Design goals:**

- PCS (1920 MHz = average of the lowest uplink and the highest downlink frequency in 1900 MHz PCS band)
- CDMA provider
- 8 CDMA carriers in the system
- -85 dBm design goal (to 95% of the building) — the minimum received power at the wireless device
- Base station with simplex RF connections

**2. Power Per Carrier:** The tables in Section 6.3, “Maximum Output Power per Carrier,” on page 6-4 provide maximum power per carrier information. The 1900 MHz CDMA table indicates that Fusion Wideband can support eight carriers with a recommended maximum power per carrier of 6.5 dBm. The input power should be set to the desired output power minus the system gain.

**3. Building information:**

- 16 floor building with 9,290 sq. meters (100,000 sq. ft.) per floor; total 148,640 sq. meters (1,600,000 sq. ft.).
- Walls are sheetrock construction, suspended ceiling tiles.
- Antennas used are omni-directional, ceiling mounted.
- Standard office environment, 80% hard wall offices and 20% cubicles.

**4. Link Budget:** In this example, a design goal of -85 dBm is used. Suppose 3 dBi omni-directional antennas are used in the design. Then, the maximum RF propagation loss should be no more than 94.5 dB (6.5 dBm + 3 dBi + 85 dBm) over 95% of the area being covered. *It is important to note that a design goal such as -85 dBm is usually derived taking into account multipath fading and log-normal shadowing characteristics. Thus, this design goal will only be met “on average” over 95% of the area being covered. At any given point, a fade may bring the signal level underneath the design goal.*

Note that this method of calculating a link budget is only for the downlink path. For information to calculate link budgets for both the downlink and uplink paths, refer to Section 6.6 on page 6-22.

**5. Path Loss Slope:** For a rough estimate, Table 6-13, “Estimated Path Loss Slope for Different In-Building Environments” on page 6-16, shows that a building with 80% hard wall offices and 20% cubicles, at 1920 MHz, has an approximate path loss slope (PLS) of 38.1. Given the RF link budget of 94.5 dB, the distance of coverage from each RAU will be 30.2 meters (99 ft). This corresponds to a coverage area of 2,868 sq. meters (30,854 sq. ft.) per RAU (refer to Section 6.5.1 for details on path loss estimation). For this case we assumed a circular radiation pattern, though the actual area covered depends upon the pattern of the antenna and the obstructions in the facility.

- 6. Equipment Required:** Since you know the building size, you can now estimate the Fusion Wideband equipment quantities needed. Before you test any RF levels in the building, you can estimate that four antennas per level will be needed. This assumes no propagation between floors. If there is propagation, you may not need antennas on every floor.
- a. 4 antennas per floor  $\times$  16 floors = 64 RAUs
  - b. 64 RAUs  $\div$  8 (maximum 8 RAUs per Expansion Hub) = 8 Expansion Hubs
  - c. 8 Expansion Hubs  $\div$  4 (maximum 4 Expansion Hubs per Main Hub) = 2 Main Hubs

Check that the fiber and CATV cable distances are as recommended. If the distances differ, use the tables in Section 6.4, "System Gain," on page 6-12 to determine system gains or losses. The path loss may need to be recalculated to assure adequate signal levels in the required coverage distance.

The above estimates assume that all cable length requirements are met. If Expansion Hubs cannot be placed so that the RAUs are within the distance requirement, additional Expansion Hubs may need to be placed closer to the required RAUs locations.

An RF Site Survey and Building Evaluation is required to accurately establish the Fusion Wideband equipment quantities required for the building. The site survey measures the RF losses within the building to determine the actual PLS, used in the final path loss formula to determine the actual requirements of the Fusion Wideband system.

## 6.6 Link Budget Analysis

A link budget is a methodical way to account for the gains and losses in an RF system so that the quality of coverage can be predicted. The end result can often be stated as a “design goal” in which the coverage is determined by the maximum distance from each RAU before the signal strength falls beneath that goal.

One key feature of the link budget is the maximum power per carrier explained in Section 6.3. While the maximum power per carrier is important as far as emissions and signal quality requirements are concerned, it is critical that the maximum signal into the Main Hub never exceed 1W (+30 dBm). Composite power levels above this limit will cause damage to the Main Hub.



**WARNING:** Exceeding the maximum input power of 1W (+30 dBm) could cause permanent damage to the Main Hub.

---

**NOTE:** Visit the ADC customer portal at [adc.com](http://adc.com) for the on-line Link Budget Tool.

---

### 6.6.1 Elements of a Link Budget for Narrowband Standards

The link budget represents a typical calculation that might be used to determine how much path loss can be afforded in a Fusion Wideband design. This link budget analyzes both the downlink and uplink paths. For most configurations, the downlink requires lower path loss and is therefore the limiting factor in the system design. It is for this reason that a predetermined “design goal” for the downlink is sufficient to predict coverage distance.

The link budget is organized in a simple manner: the transmitted power is calculated, the airlink losses due to fading and body loss are summed, and the receiver sensitivity (minimum level a signal can be received for acceptable call quality) is calculated. The maximum allowable path loss (in dB) is the difference between the transmitted power, less the airlink losses, and the receiver sensitivity. From the path loss, the maximum coverage distance can be estimated using the path loss formula presented in Section 6.5.1.

Table 6-21 provides link budget considerations for narrowband systems.

**Table 6-21 Link Budget Considerations for Narrowband Systems**

<b>Consideration</b>	<b>Description</b>												
BTS Transmit Power	The power per carrier transmitted from the base station output												
Attenuation between BTS and Fusion Wideband	<p>This includes all losses: cable, attenuator, splitter/combiner, and so forth.</p> <p>On the downlink, attenuation must be chosen so that the maximum power per carrier going into the Main Hub does not exceed the levels given in Section 6.3.</p> <p>On the uplink, attenuation is chosen to keep the maximum uplink signal and noise level low enough to prevent base station alarms but small enough not to cause degradation in the system sensitivity.</p> <p>If the Fusion Wideband noise figure minus the attenuation is at least 10 dB higher than the BTS noise figure, the system noise figure is approximately that of Fusion Wideband alone. Refer to Section 6.8 for ways to independently set the uplink and downlink attenuations between the base station and Fusion Wideband.</p>												
Antenna Gain	The radiated output power includes antenna gain. For example, if you use a 3 dBi antenna at the RAU that is transmitting 0 dBm per carrier, the effective radiated power (relative to an isotropic radiator) is 3 dBm per carrier.												
BTS Noise Figure	This is the effective noise floor of the base station input (usually base station sensitivity is this effective noise floor plus a certain C/I ratio).												
Fusion Wideband Noise Figure	This is Fusion Wideband's uplink noise figure, which varies depending on the number of Expansion Hubs and RAUs, and the frequency band. Fusion Wideband's uplink noise figure is specified for a 1-1-8 configuration. Thus, the noise figure for a Fusion Wideband system (or multiple systems whose uplink ports are power combined) is $NF(1-1-8) + 10 \cdot \log(\# \text{ of Expansion Hubs})$ . This represents an upper-bound because the noise figure is lower if any of the Expansion Hub's RAU ports are <b>not</b> used.												
Thermal Noise	<p>This is the noise level in the signal bandwidth (BW).</p> <p>Thermal noise power = <math>-174 \text{ dBm/Hz} + 10 \text{Log}(\text{BW})</math>.</p> <table border="1" style="margin-left: auto; margin-right: auto;"> <thead> <tr> <th><b>Protocol</b></th> <th><b>Signal Bandwidth</b></th> <th><b>Thermal Noise</b></th> </tr> </thead> <tbody> <tr> <td>TDMA</td> <td>30 kHz</td> <td>-129 dBm</td> </tr> <tr> <td>GSM</td> <td>200 kHz</td> <td>-121 dBm</td> </tr> <tr> <td>iDEN</td> <td>25 kHz</td> <td>-130 dBm</td> </tr> </tbody> </table>	<b>Protocol</b>	<b>Signal Bandwidth</b>	<b>Thermal Noise</b>	TDMA	30 kHz	-129 dBm	GSM	200 kHz	-121 dBm	iDEN	25 kHz	-130 dBm
<b>Protocol</b>	<b>Signal Bandwidth</b>	<b>Thermal Noise</b>											
TDMA	30 kHz	-129 dBm											
GSM	200 kHz	-121 dBm											
iDEN	25 kHz	-130 dBm											
Required C/I ratio	For each wireless standard, a certain C/I (carrier to interference) ratio is needed to obtain acceptable demodulation performance. For narrowband systems, (TDMA, GSM, EDGE, iDEN, AMPS) this level varies from about 9 dB to 20 dB.												
Mobile Transmit Power	The maximum power the mobile can transmit (power transmitted at highest power level setting).												
Multipath Fade Margin	This margin allows for a certain level of fading due to multipath interference. Inside buildings there is often one or more fairly strong signals and many weaker signals arriving from reflections and diffraction. Signals arriving from multiple paths add constructively or destructively. This margin accounts for the possibility of destructive multipath interference. In RF site surveys the effects of multipath fading are typically not accounted for because such fading is averaged out over power level samples taken over many locations.												

---

**Link Budget Analysis**

---

**Table 6-21 Link Budget Considerations for Narrowband Systems (continued)**

<b>Consideration</b>	<b>Description</b>
Log-normal Fade Margin	This margin adds an allowance for RF shadowing due to objects obstructing the direct path between the mobile equipment and the RAU. In RF site surveys, the effects of shadowing are partially accounted for since it is characterized by relatively slow changes in power level.
Body Loss	This accounts for RF attenuation caused by the user's head and body.
Minimum Received Signal Level	This is also referred to as the "design goal". The link budget says that you can achieve adequate coverage if the signal level is, on average, above this level over 95% of the area covered, for example.



## 6.6.2 Narrowband Link Budget Analysis for a Microcell Application

Table 6-22 Narrowband Link Budget Analysis: Downlink

Line	Downlink	
<b>Transmitter</b>		
a.	BTS transmit power per carrier (dBm)	33
b.	Attenuation between BTS and Fusion Wideband (dB)	-23
c.	Power into Fusion Wideband (dBm)	10
d.	Fusion Wideband gain (dB)	0
e.	Antenna gain (dBi)	3
f.	Radiated power per carrier (dBm)	<b>13</b>
<b>Airlink</b>		
g.	Multipath fade margin (dB)	6
h.	Log-normal fade margin with 9 dB std. deviation, 95% area coverage, 87% edge coverage	10
i.	Body loss (dB)	3
j.	Airlink losses (not including facility path loss)	<b>19</b>
<b>Receiver</b>		
k.	Thermal noise (dBm/30 kHz)	-129
l.	Mobile noise figure (dB)	7
m.	Required C/I ratio (dB)	17
n.	Minimum received signal (dBm)	<b>-105</b>
p.	<b>Maximum path loss (dB)</b>	<b>+99</b>

- $c = a + b$
- $f = c + d + e$
- $j = g + h + i$
- $n = k + l + m$
- k: in this example, k represents the thermal noise for a TDMA signal, which has a bandwidth of 30 kHz
- $p = f - j - n$

**Table 6-23 Narrowband Link Budget Analysis: Uplink**

Line	Uplink	
<b>Receiver</b>		
a.	BTS noise figure (dB)	4
b.	Attenuation between BTS and Fusion Wideband (dB)	-10
c.	Fusion Wideband gain (dB)	0
d.	Fusion Wideband noise figure (dB) 1-4-32	22
e.	System noise figure (dB)	22.6
f.	Thermal noise (dBm/30 kHz)	-129
g.	Required C/I ratio (dB)	12
h.	Antenna gain (dBi)	3
i.	Receive sensitivity (dBm)	<b>-97.4</b>
<b>Airlink</b>		
j.	Multipath fade margin (dB)	6
k.	Log-normal fade margin with 9 dB std. deviation, 95% area coverage, 87% edge coverage	10
l.	Body loss (dB)	3
m.	Airlink losses (not including facility path loss)	<b>19</b>
<b>Transmitter</b>		
n.	Mobile transmit power (dBm)	28
p.	<b>Maximum path loss (dB)</b>	<b>106.4</b>

- e: enter the noise figure and gain of each system component (a, b, c, and d) into the standard cascaded noise figure formula

$$F_{sys} = F_1 + \frac{F_2 - 1}{G_1} + \frac{F_3 - 1}{G_1 G_2} + \dots$$

where

$$F = 10^{(\text{Noise Figure}/10)}$$

$$G = 10^{(\text{Gain}/10)}$$

(See Rappaport, Theodore S. *Wireless Communications, Principles, and Practice*. Prentice Hall PTR, 1996.)

- $i = f + e + g - h$
- $m = j + k + l$
- $p = n - m - i$

Therefore, the system is downlink limited but the downlink and uplink are almost balanced, which is a desirable condition.

### 6.6.3 Elements of a Link Budget for CDMA Standards

A CDMA link budget is slightly more complicated because you must consider the spread spectrum nature of CDMA. Unlike narrowband standards such as TDMA and GSM, CDMA signals are spread over a relatively wide frequency band. Upon reception, the CDMA signal is de-spread. In the de-spreading process the power in the received signal becomes concentrated into a narrow band, whereas the noise level remains unchanged. Hence, the signal-to-noise ratio of the de-spread signal is higher than that of the CDMA signal before de-spreading. This increase is called *processing gain*. For IS-95 and J-STD-008, the processing gain is 21 dB or 19 dB depending on the user data rate (9.6 Kbps for rate set 1 and 14.4 Kbps for rate set 2, respectively). Because of the processing gain, a CDMA signal (comprising one Walsh code channel within the composite CDMA signal) can be received at a lower level than that required for narrowband signals. A reasonable level is  $-95$  dBm, which results in about  $-85$  dBm composite as shown below.

An important issue to keep in mind is that the downlink CDMA signal is composed of many orthogonal channels: pilot, paging, sync, and traffic. The composite power level is the sum of the powers from the individual channels. Table 6-24 shows an example.

**Table 6-24 Distribution of Power within a CDMA Signal**

Channel	Walsh Code Number	Relative Power Level	
Pilot	0	20%	$-7.0$ dB
Sync	32	5%	$-13.3$ dB
Primary Paging	1	19%	$-7.3$ dB
Traffic	8–31, 33–63	9% (per traffic channel)	$-10.3$ dB

This table assumes that there are 15 active traffic channels operating with 50% voice activity (so that the total power adds up to 100%). Notice that the pilot and sync channels together contribute about 25% of the power. When measuring the power in a CDMA signal you must be aware that if only the pilot and sync channels are active, the power level will be about 6 to 7 dB lower than the maximum power level you can expect when all voice channels are active. The implication is that if only the pilot and sync channels are active, and the maximum power per carrier table says that you should not exceed 10 dBm for a CDMA signal, for example, then you should set the attenuation between the base station and the Main Hub so that the Main Hub receives 3 dBm (assuming 0 dB system gain).

An additional consideration for CDMA systems is that the uplink and downlink paths should be gain and noise balanced. This is required for proper operation of soft-hand-off to the outdoor network as well as preventing excess interference that is caused by mobiles on the indoor system transmitting at power levels that are not coordinated with the outdoor mobiles. This balance is achieved if the power level transmitted by the mobiles under close-loop power control is similar to the power level transmitted under open-loop power control.

The open-loop power control equation is

$$P_{TX} + P_{RX} = -73 \text{ dBm (for Cellular, IS-95)}$$

$$P_{TX} + P_{RX} = -76 \text{ dBm (for PCS, J-STD-008)}$$

where  $P_{TX}$  is the mobile's transmitted power and  $P_{RX}$  is the power received by the mobile.

The power level transmitted under closed-loop power control is adjusted by the base station to achieve a certain  $E_b/N_0$  (explained in Table 6-25 on page 6-28). The difference between these power levels,  $\Delta_p$ , can be estimated by comparing the power radiated from the RAU,  $P_{downlink}$ , to the minimum received signal,  $P_{uplink}$ , at the RAU:

$$\Delta_p = P_{downlink} + P_{uplink} + 73 \text{ dBm (for Cellular)}$$

$$\Delta_p = P_{downlink} + P_{uplink} + 76 \text{ dBm (for PCS)}$$

It's a good idea to keep  $-12 \text{ dB} < \Delta_p < 12 \text{ dB}$ .

Table 6-25 provides link budget considerations for CDMA systems.

**Table 6-25 Additional Link Budget Considerations for CDMA**

<b>Consideration</b>	<b>Description</b>
Multipath Fade Margin	The multipath fade margin can be reduced (by at least 3 dB) by using different lengths of optical fiber (this is called "delay diversity"). The delay over fiber is approximately 5μS/km. If the difference in fiber lengths to Expansion Hubs with overlapping coverage areas produces at least 1 chip (0.8μS) delay of one path relative to the other, then the multipaths' signals can be resolved and processed independently by the base station's rake receiver. A CDMA signal traveling through 163 meters of MMF cable is delayed by approximately one chip.
Power per carrier, downlink	This depends on how many channels are active. For example, the signal is about 7 dB lower if only the pilot, sync, and paging channels are active compared to a fully-loaded CDMA signal. Furthermore, in the CDMA forward link, voice channels are turned off when the user is not speaking. On average this is assumed to be about 50% of the time. So, in the spreadsheet, both the power per Walsh code channel (representing how much signal a mobile will receive on the Walsh code that it is de-spreading) and the total power are used.  The channel power is needed to determine the maximum path loss, and the total power is needed to determine how hard the Fusion Wideband system is being driven.  The total power for a fully-loaded CDMA signal is given by (approximately):  total power = voice channel power + 13 dB + $10\log_{10}(50\%)$ = voice channel power + 10 dB
Information Rate	This is simply  $10\log_{10}(9.6 \text{ Kbps}) = 40 \text{ dB}$ for rate set 1  $10\log_{10}(14.4 \text{ Kbps}) = 42 \text{ dB}$ for rate set 2

Table 6-25 Additional Link Budget Considerations for CDMA (continued)

Consideration	Description
Process Gain	<p>The process of de-spreading the desired signal boosts that signal relative to the noise and interference. This gain needs to be included in the link budget. In the following formulas, <math>P_G</math> = process gain:</p> $P_G = 10\log_{10}(1.25 \text{ MHz} / 9.6 \text{ Kbps}) = 21 \text{ dB rate set 1}$ $P_G = 10\log_{10}(1.25 \text{ MHz} / 14.4 \text{ Kbps}) = 19 \text{ dB rate set 2}$ <p>Note that the process gain can also be expressed as <math>10\log_{10}</math> (CDMA bandwidth) minus the information rate.</p>
Eb/No	<p>This is the energy-per-bit divided by the received noise and interference. It's the CDMA equivalent of signal-to-noise ratio (SNR). This figure depends on the mobile's receiver and the multipath environment. For example, the multipath delays inside a building are usually too small for a rake receiver in the mobile (or base station) to resolve and coherently combine multipath components. However, if artificial delay can be introduced by, for instance, using different lengths of cable, then the required <math>E_b/N_o</math> is lower and the multipath fade margin in the link budget can be reduced in some cases.</p> <p>If the receiver noise figure is NF (dB), then the receive sensitivity (dBm) is given by:</p> $P_{\text{sensitivity}} = NF + E_b/N_o + \text{thermal noise in a 1.25 MHz band} - P_G$ $= NF + E_b/N_o - 113 \text{ (dBm/1.25 MHz)} - P_G$
Noise Rise	<p>On the uplink, the noise floor is determined not only by the Fusion Wideband system, but also by the number of mobiles that are transmitting. This is because when the base station attempts to de-spread a particular mobile's signal, all other mobile signals appear to be noise. Because the noise floor rises as more mobiles try to communicate with a base station, the more mobiles there are, the more power they have to transmit. Hence, the noise floor rises rapidly:</p> $\text{noise rise} = 10\log_{10}(1 / (1 - \text{loading}))$ <p>where <i>loading</i> is the number of users as a percentage of the theoretical maximum number of users.</p> <p>Typically, a base station is set to limit the loading to 75%. This noise ratio must be included in the link budget as a worst-case condition for uplink sensitivity. If there are less users than 75% of the maximum, then the uplink coverage will be better than predicted.</p>
Hand-off Gain	<p>CDMA supports soft hand-off, a process by which the mobile communicates simultaneously with more than one base station or more than one sector of a base station. Soft hand-off provides improved receive sensitivity because there are two or more receivers or transmitters involved. A line for hand-off gain is included in the CDMA link budgets worksheet although the gain is set to 0 dB because the in-building system will probably be designed to limit soft-handoff.</p>

### Other CDMA Issues

- Never combine multiple sectors (more than one CDMA signal at the same frequency) into a Fusion Wideband system. The combined CDMA signals will interfere with each other.
- Try to minimize overlap between in-building coverage areas that utilize different sectors, as well as in-building coverage and outdoor coverage areas. This is important because any area in which more than one dominant pilot signal (at the same frequency) is measured by the mobile will result in soft-handoff. Soft-handoff decreases the overall network capacity by allocating multiple channel resources to a single mobile phone.

### 6.6.4 CDMA Link Budget Analysis for a Microcell Application

Table 6-26 CDMA Link Budget Analysis: Downlink

Line	Downlink	
<b>Transmitter</b>		
a.	BTS transmit power per traffic channel (dBm)	30.0
b.	Voice activity factor	50%
c.	Composite power (dBm)	40.0
d.	Attenuation between BTS and Fusion Wideband (dB)	-24
e.	Power per channel into Fusion Wideband (dBm)	9.0
f.	Composite power into Fusion Wideband (dBm)	16.0
g.	Fusion Wideband gain (dB)	0.0
h.	Antenna gain (dBi)	3.0
i.	Radiated power per channel (dBm)	12.0
j.	Composite radiated power (dBm)	<b>19.0</b>
<b>Airlink</b>		
k.	Handoff gain (dB)	0.0
l.	Multipath fade margin (dB)	6.0
m.	Log-normal fade margin with 9 dB std. deviation, 95% area coverage, 87% edge coverage	10.0
n.	Additional loss (dB)	0.0
o.	Body loss (dB)	3.0
p.	Airlink losses (not including facility path loss)	<b>19.0</b>
<b>Receiver</b>		
q.	Mobile noise figure (dB)	7.0
r.	Thermal noise (dBm/Hz)	-174.0
s.	Receiver interference density (dBm/Hz)	-167.0
t.	Information ratio (dB/Hz)	41.6
u.	Required $E_b/(N_o+I_o)$	7.0
v.	Minimum received signal (dBm)	-118.4
w.	<b>Maximum path loss (dB)</b>	<b>+99.4</b>

- b and c: see notes in Table 6-25 regarding power per carrier, downlink
- $e = a + d$
- $f = c + d$
- $i = e + g + h$
- $j = f + g + h$
- $p = -k + l + m + n + o$
- $s = q + r$
- $v = s + t + u$
- $w = j - p - v$
- $x = j$  (downlink) +  $m$  (uplink) +  $P$

where

$$P = P_{tx} + P_{rx} = \begin{array}{l} -73 \text{ dB for Cellular} \\ -76 \text{ dB for PCS} \end{array}$$

Table 6-27 CDMA Link Budget Analysis: Uplink

Line	Uplink	
	<b>Receiver</b>	
a.	BTS noise figure (dB)	3.0
b.	Attenuation between BTS and Fusion Wideband (dB)	-30.0
c.	Fusion Wideband gain (dB)	0.0
d.	Fusion Wideband noise figure (dB)	22.0
e.	System noise figure (dB)	33.3
f.	Thermal noise (dBm/Hz)	-174.0
g.	Noise rise 75% loading (dB)	6.0
h.	Receiver interference density (dBm/Hz)	-134.6
i.	Information rate (dB/Hz)	41.6
j.	Required $E_b/(N_o+I_o)$	5.0
k.	Handoff gain (dB)	0.0
l.	Antenna gain (dBi)	3.0
m.	Minimum received signal (dBm)	<b>-91.1</b>
	<b>Airlink</b>	
n.	Multipath fade margin (dB)	6.0
o.	Log-normal fade margin with 9 dB std. deviation, 95% area coverage, 87% edge coverage	10.0
p.	Additional loss (dB)	0.0
q.	Body loss (dB)	3.0
r.	Airlink losses (not including facility path loss)	<b>19.0</b>
	<b>Transmitter</b>	
s.	Mobile transmit power (dBm)	28.0
t.	<b>Maximum path loss (dB)</b>	<b>100.1</b>



- e: enter the noise figure and gain of each system component (a, b, c, and d) into the standard cascaded noise figure formula

$$F_{sys} = F_1 + \frac{F_2 - 1}{G_1} + \frac{F_3 - 1}{G_1 G_2} + \dots$$

where

$$F = 10^{(\text{Noise Figure}/10)}$$

$$G = 10^{(\text{Gain}/10)}$$

(See Rappaport, Theodore S. *Wireless Communications, Principles, and Practice*. Prentice Hall PTR, 1996.)

- $h = e + f + g$
- $m = h + i + j - k - l$
- $r = n + o + p + q$
- $t = s - r - m$

### 6.6.5 Considerations for Re-Radiation (Over-the-Air) Systems

Fusion Wideband can be used to extend the coverage of the outdoor network by connecting to a roof-top donor antenna pointed toward an outdoor base station. Additional considerations for such an application of Fusion Wideband are:

- Sizing the gain and output power requirements for a bi-directional amplifier (repeater).
- Ensuring that noise radiated on the uplink from the in-building system does not cause the outdoor base station to become desensitized to wireless handsets in the outdoor network.
- Filtering out signals that lie in adjacent frequency bands. For instance, if you are providing coverage for Cellular B-band operation it may be necessary to filter out the A, A' and A'' bands which may contain strong signals from other outdoor base stations.

Further information on these issues can be found in ADC application notes for re-radiation applications.

## 6.7 Optical Power Budget

Fusion Wideband uses SC/APC connectors. The connector losses associated with mating to these connectors is accounted for in the design and *should not* be included as elements of the optical power budget. The reason is that when the optical power budget is defined, measurements are taken with these connectors in place.

**The Fusion Wideband optical power budget for both multi-mode and single-mode fiber cable is 3.0 dB (optical).**

The maximum loss through the fiber can not exceed 3 dB (optical). The maximum lengths of the fiber cable should not exceed 500m (1,640 ft) for multi-mode and 6 km (19,685 ft) for single-mode. Both the optical budget and the maximum cable length must be taken into consideration when designing the system.

---

**NOTE:** It is critical to system performance that only SC/APC fiber connectors are used throughout the fiber network, including fiber distribution panels.

---

## 6.8 Connecting a Main Hub to a Base Station

The Fusion Wideband system supports up to three RF sources: one for Band 1, one for Band 2 and one for Band 3. This section explains how each band can be connected to its associated base station.

Each Fusion Main Hub band has separate system gain parameters. For example, Band 1 can be set for +5 dB of downlink system gain while Band 2 can have +15 dB of downlink system gain. Thus, each band can be configured as a separate system to allow for full integration to its associated base station.

When connecting each of the Fusion Wideband Main Hub bands to its base station, the following equipment may be required: circulators, filter diplexers, directional couplers, combiner/splitters, attenuators, coax cables, and connectors. In addition, use the following considerations to achieve optimal performance:

1. The downlink power from the base stations must be attenuated enough so that the power radiated by the RAU does not exceed the maximum power per carrier listed in Section 6.3, “Maximum Output Power per Carrier,” on page 6-4.
2. The uplink attenuation should be small enough that the sensitivity of the overall system is limited by Fusion Wideband, not by the attenuator. However, some base stations trigger alarms if the noise or signal levels are too high. In this case the attenuation must be large enough to prevent this from happening.

---

**CAUTION:** The **UPLINK** and **DOWNLINK** ports cannot handle a DC power feed from a BTS. If DC power is present, a DC block must be used or the Fusion Wideband Main Hub may be damaged.

---

If, in an area covered by Fusion Wideband, a mobile phone indicates good signal strength but consistently has difficulty completing calls, it is possible that the attenuation between Fusion Wideband and the base station needs to be adjusted. In other words, it is possible that if the uplink is over-attenuated, the downlink power will provide good coverage, but the uplink coverage distance will be small.

When there is an excessive amount of loss between the Fusion Wideband Main Hub uplink and its associated band’s base station, the uplink system gain can be increased to as much as 15 dB to prevent a reduction in the overall system sensitivity.

### 6.8.1 Uplink Attenuation

The attenuation between the Main Hub’s uplink port and the associated band’s base station reduces both the noise level and the desired signals out of Fusion Wideband. Setting the attenuation on the uplink is a trade-off between keeping the noise and maximum signal levels transmitted from Fusion Wideband to the base station receiver low while not reducing the SNR (signal-to-noise ratio) of the path from the

RAU inputs to the base station inputs. This SNR can not be better than the SNR of Fusion Wideband by itself, although it can be significantly worse.

A good rule of thumb is to set the uplink attenuation such that the noise level out of Fusion Wideband is within 10 dB of the base station's sensitivity.

## **6.8.2 RAU Attenuation and ALC**

The RAU attenuation and ALC are set using the AdminBrowser **Edit Unit Properties** screen.

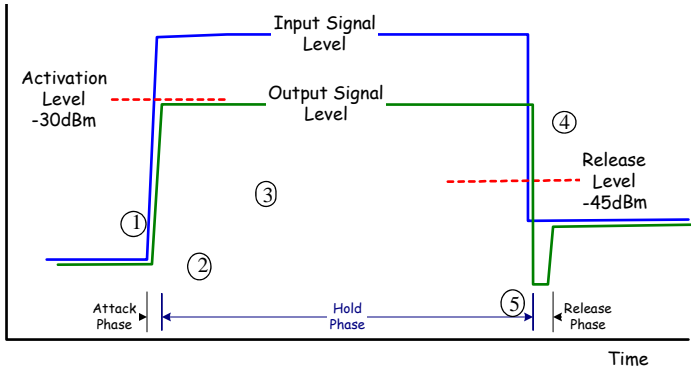
Embedded within the uplink RF front-end of each Fusion Wideband RAU band is an ALC circuit. This ALC circuit protects the Fusion Wideband system from overload and excessive intermodulation products due to high-powered mobiles or other signal sources that are within the supported frequency band and are in close proximity to the RAU.

Each individual Band (1 or 2) of a Fusion Wideband RAU has an uplink ALC circuit that operates as a feedback loop. A power detector measures the level of each band's uplink RF input and if that level exceeds  $-30$  dBm, an RF attenuator is activated. The level of attenuation is equal to the amount that the input exceeds  $-30$  dBm. The following sequence describes the operation of the ALC circuit, as illustrated in Figure 6-2.

1. The RF signal level into either Band of the RAU rises above the activation threshold ( $-30$  dBm), causing that ALC loop to enter into the attack phase.
2. During the attack phase, the ALC loop increases the attenuation (0 to 30 dB) until the detector reading is reduced to the activation threshold. The duration of this attack phase is called the attack time.
3. After the attack time, the ALC loop enters the hold phase and maintains a fixed attenuation so long as the high-level RF signal is *present*.
4. The RF signal level drops below the release threshold ( $-45$  dBm) and the ALC loop enters the release phase.
5. During the release phase, the ALC loop holds the attenuation for a fixed period then quickly releases the attenuation.

An important feature of the ALC loop is that in Step 3, the attenuation is maintained at a fixed level until the signal drops by a significant amount. This prevents the ALC loop from tracking variations in the RF signal itself and distorting the waveform modulation.

Figure 6-2 ALC Operation



6.8.2.1 Using the RAU 10 dB Attenuation Setting

Each RAU band can, independently of the other RAUs in a system, have its uplink or downlink gain attenuated by 0 or 10 dB for each RAU band (1, 2 or 3). This is accomplished by selecting the appropriate UPLINK and/or DOWNLINK attenuation for each RAU band in the **Edit Unit Properties** screen of AdminBrowser for the selected RAU.

- **Downlink Attenuation:** The downlink attenuator provides a mechanism to reduce the signal strength from an RAU band. For instance, this could be for an RAU band located near a window in a tall building that is causing excessive leakage to the macro-network. In such a case it is important to attenuate the downlink only. The uplink should not be attenuated. If the uplink is attenuated, the uplink sensitivity is reduced and mobile phones in the area of that RAU band will have to transmit at a higher power. This would increase interference to the outdoor network from such mobiles.
- **Uplink Attenuation:** The uplink attenuator attenuates environmental noise picked up by an RAU band located in an area where heavy electrical machinery is operating. In such environments the electrical noise can be quite high and it is useful to reduce the amount of such noise that gets propagated through the distributed antenna system. Attenuating the uplink of an RAU band located in areas of high electrical noise helps preserve the sensitivity of the rest of the system.

The effect of activating the uplink or downlink attenuators is to reduce the coverage area of the adjusted RAU band. The coverage radius will be reduced by roughly a factor of 2. More specifically, if *d* is the coverage distance without attenuation and *d'* is the coverage radius with the attenuation, then

$$\frac{d}{d'} = 10^{10dB/PLS}$$

where PLS is path loss slope (dBm).

### 6.8.2.2 Using the Uplink ALC Setting

Uplink automatic level control (UL ALC) circuitry for each band within the RAU provides automatic level control on high-power signals in the uplink path. This functionality is required to prevent RF signal compression caused by a single or multiple wireless devices in very close proximity to the RAU band. Compression causes signal degradation and, ultimately, dropped calls and data errors, and should be prevented. Two settings are available to optimize UL ALC performance:

- **Multiple Operators:** Use when more than one operator and/or protocol is present in the Fusion Wideband system's band frequency or adjacent frequency bands. This setting is most commonly used.
- **Single Operator and Protocol:** Use when only one operator and protocol is on-the-air within the Fusion Wideband system's configured and adjacent frequency bands. This setting is seldom used.

# Installing Fusion Wideband

---

This section contains the following subsections:

- Section 7.1 Installation Requirements . . . . . 7-1
- Section 7.2 Safety Precautions . . . . . 7-3
- Section 7.3 Preparing for System Installation . . . . . 7-6
- Section 7.4 Fusion Wideband Installation Procedures . . . . . 7-10
- Section 7.5 Splicing Fiber Optic Cable . . . . . 7-44
- Section 7.6 Interfacing the Fusion Wideband Main Hub to an RF Source . . 7-46
- Section 7.7 Connecting Contact Alarms to a Fusion Wideband System . . . 7-56
- Section 7.8 Alarm Monitoring Connectivity Options . . . . . 7-63

---

## 7.1 Installation Requirements

Before and during installation, keep in mind these sources of potential problems:

- Faulty cabling/connector
- Dirty connectors and ports
- Malfunction of one or more Fusion Wideband components
- Antenna, base station, or repeater problem
- External RF interface
- Tripped circuit breaker
- Equipment is not grounded
- Using a crossover Ethernet cable that does not support full hardware handshaking when using AdminBrowser

---

**NOTE:** Faulty cabling is the cause of a vast majority of problems. All CATV cable should be tested to TIA-570-B specifications.

---

### **7.1.1 Component Location Requirements**

Fusion Wideband components are intended to be installed in indoor locations only.

If outdoor installation is desired, such as a parking garage, the Fusion Wideband components must be installed in the appropriate environmental enclosures.

### **7.1.2 Cable and Connector Requirements**

Fusion Wideband equipment operates over the following:

- CATV 75 Ohm cable with F connectors
- Single-mode fiber (SMF) or multi-mode (MMF) cable with SC/APC fiber connectors throughout the fiber network, including fiber distribution panels

These cables are widely-used, industry standards for the cable TV industry. The regulations and guidelines for Fusion Wideband cable installation are identical to those specified by the TIA/EIA 568-B standard and the TIA/EIA/570-A standards.

ADC recommends solid copper center conductor, plenum-rated CATV cable and connectors for conformity to building codes, standards, and to ensure stated performance of maximum distance and RF specifications.

CommScope 2065V cable or equivalent is required for RG-59.

CommScope 2279V cable or equivalent is required for RG-6.

CommScope 2293K cable may also be used for RG-11.

---

**NOTE:** Refer to Appendix A for more information related to 75 Ohm CATV.

---

ADC recommends connectors with fixed centerpins to ensure proper seating and to eliminate oxidation, which occurs with bare center conductors. Recommended connectors are as follows:

#### **CANARE Connectors**

- FP-C4F for CommScope 2065V cable
- FP-C55A for CommScope 2279V cable
- FP-C71A for CommScope 2293K cable



**NOTE:** The proper crimp tool and die must be matched by the connector type.

### 7.1.3 Distance Requirements

Table 7-1 shows the distances between Fusion Wideband components and related equipment.

**Table 7-1 Distance Requirements**

Equipment Combination	Cable Type	Cable Length	Additional Information
Repeater/BTS to Fusion Wideband Main Hub	Coaxial; N male connectors	3–6 m (10–20 ft) typical  10 m (33 ft) maximum	Limited by loss and noise. Refer to your link budget calculation. Limited by CE Mark requirements.
Fusion Wideband Expansion Hub to RAU	CATV 75 Ohm; shielded F male connectors	<ul style="list-style-type: none"> <li>• Minimum: 10 meters (33 ft)</li> <li>• Maximum: 130 meters (426 ft) for RG-59; 140 meters (459 ft) for RG-6; 235 meters (771 ft) for RG-11</li> </ul> Refer to Table 5-1 and Table 5-2.	Refer to “System Gain” on page 6-12.
Main Hub to Expansion Hub	Multi-mode fiber: Single-mode fiber: SC/APC male connectors	500 m (1640 ft.) maximum 6 km (19,685 ft.) maximum	Limited by 3 dB optical attenuation
RAU to passive antenna	Coaxial; N male connectors	1–3.5 m (3–12 ft) typical	Limited by loss and noise. Refer to your link budget calculation.

## 7.2 Safety Precautions

### 7.2.1 Installation Guidelines

Use the following guidelines when installing ADC equipment:

1. Provide sufficient airflow and cooling to the equipment to prevent heat build-up from exceeding the maximum ambient air temperature specification. Do not compromise the amount of airflow required for safe operation of the equipment.
2. If you are removing the system, turn it off and remove the power cord first. There are no user-serviceable parts inside the components.

3. The internal power supplies have internal fuses that are not user replaceable. Consider the worst-case power consumption shown on the product labels when provisioning the equipment's AC power source and distribution.
4. Verify that the Hub is grounded properly using the AC power cord third wire ground.

---

**NOTE:** Be careful with the mechanical loading of the rack mounted hub. Mount the equipment in the rack in such a way that a hazardous condition, due to uneven mechanical loading, does not result.

---

### 7.2.2 General Safety Precautions

The following precautions apply to ADC products:

- The units have no user-serviceable parts. Faulty or failed units are fully replaceable through ADC. Please contact us at:  
1-800-530-9960 (U.S. only)  
+1-408-952-2400 (International)
- When you connect the fiber optic cable, clean all optical fiber SC/APC connectors according to the cable manufacturer's instructions.
- When you connect a radiating antenna to an RAU, firmly hand-tighten the N connector – DO NOT over-tighten the connector.



**WARNING:** To reduce the risk of fire or electric shock, do not expose this equipment to rain or moisture. The components are intended for indoor use only. Do not install the RAU outdoors. Do not connect an RAU to an antenna that is located outdoors where it could be subject to lightning strikes, power crosses, or wind.

---

- The Expansion Hub and RAU units are designed for intra-building cabling only. Outdoor routing of any cabling to these units shall not exceed 140 feet.

---

**NOTE:** Outdoor cables farther than 140 feet must be installed with proper lightning protection.

---

### 7.2.3 Fiber Port Safety Precautions

The following are suggested safety precautions for working with fiber ports. For information about system compliance with safety standards, refer to Appendix B.



**WARNING:** Observe the following warning about viewing fiber ends in ports. Do not stare with unprotected eyes at the connector ends of the fibers or the ports of the hubs. Invisible infrared radiation is present at the front panel of the Main Hub and the Expansion Hub. Do not remove the fiber port dust caps unless the port is going to be used. Do not stare directly into a fiber port.

---

- **Test fiber cables:** When you test fiber optic cables, connect the optical power source last and disconnect it first. Use Class 1 test equipment.
- **Fiber ends:** Cover any unconnected fiber ends with an approved cap. Do not use tape.
- **Broken fiber cables:** Do not stare with unprotected eyes at any broken ends of the fibers. Laser light emitted from fiber sources can cause eye injury. Avoid contact with broken fibers; they are sharp and can pierce the skin. Report any broken fiber cables and have them replaced.
- **Cleaning:** Be sure the connectors are clean and free of dust or oils. Use only approved methods for cleaning optical fiber connectors.
- **Modifications:** Do not make any unauthorized modifications to this fiber optic system or associated equipment.
- **Live work:** Live work is permitted because ADC equipment is a Class 1 hazard.
- **Signs:** No warning signs are required.
- **Class 1 laser product:** The system meets the criteria for a Class 1 laser product per IEC 60825-1: 1993+A1:+A2:2001 and IEC106825-2.

**CLASS 1  
LASER PRODUCT**

This mark appears on the front panel of the Main Hub and the Expansion Hub.

Complies with 21 CFR 1040.10 and 1040.11 except for deviations pursuant to Laser Notice No. 50, dated July 26, 2001.

The hazard level at all locations within the equipment is Hazard Level 1.

- **CAUTION:** Use of controls or adjustments or performance of procedures other than those specified herein may result in hazardous radiation exposure.

## 7.3 Preparing for System Installation

### 7.3.1 Pre-Installation Inspection

Follow this procedure before installing Fusion Wideband equipment:

1. Verify the number of packages received against the packing list.
2. Check all packages for external damage; report any external damage to the shipping carrier. If there is damage, a shipping agent should be present before you unpack and inspect the contents because damage caused during transit is the responsibility of the shipping agent.
3. Open and check each package against the packing list. If any items are missing, contact ADC customer service (refer to Section 7.2.2 on page 7-4).
4. If damage is discovered at the time of installation, contact the shipping agent.

### 7.3.2 Installation Checklist

**Table 7-2 Installation Checklist**

✓	Installation Requirement	Consideration
	Floor Plans	Installation location of equipment clearly marked
	System Design	Used to verify frequency bands after installation
	Power available: Fusion Wideband Main Hub (AC) Fusion Wideband Expansion Hub (AC) To RAU (DC)  Fusion Wideband Main Hub (DC) Fusion Wideband Expansion Hub (DC)	Hub's power cord is 2 m (6.5 ft) long. 100/240V, 1A, 50–60 Hz 100/240V, 6A, 50-60 Hz 54V (from the Hub)  38–64VDC, 2.5A 38–64VDC, 14A
	Rack space available (Main and Expansion Hub)	89 mm (3.5 in.) high (2U)
	Wallmount Fusion Wideband Main Hub	Hub must be mounted on 3/4" plywood backboard.
	Clearance for air circulation: Fusion Wideband Main or Expansion Hub RAU	76 mm (3 in.) front and rear, 51 mm (2 in.) sides 76 mm (3 in.) all around
	Suitable operating environment: Fusion Wideband Main or Expansion Hub  RAUs	Indoor location only 0° to +45°C (+32° to +113°F) 5% to 95% non-condensing humidity  –25° to +45°C (–13° to +113°F) 5% to 95% non-condensing humidity
<b>Donor Antenna-to-Fusion Wideband Configuration (for each Fusion Wideband Band)</b>		
	Donor Antenna	Installed, inspected; N-male to N-male coaxial cable to lightning arrestor/surge suppressor
	Lightning Arrestor or Surge Suppressor	Installed between roof-top antenna and repeater; N-male to N-male 50 Ohm coaxial cable and outdoor cables longer than 140 feet.

Table 7-2 Installation Checklist (continued)

✓	Installation Requirement	Consideration
	Repeater	Installed between lightning arrestor/surge suppressor and Hub; N-male to N-male coaxial cable. The Repeater must be a UL listed product.
	Attenuator	Installed between the circulator and the Hub downlink port to prevent overload. Optionally, it may be installed between the uplink port and the circulator.
	Circulator or Duplexer	Installed between the repeater and the Hub uplink and downlink ports
<b>Base Station-to-Fusion Wideband Configuration (for each Fusion Wideband Band)</b>		
	Base Station	Installed, inspected; verify RF power (see tables in Section 6.3 on page 6-4); N-male to N-male coaxial cable
	Attenuator	Attenuation may be required to achieve the desired RF output at the RAU, and the desired uplink noise floor level
	Circulator or Duplexer	When using a duplex BTS: Installed between the BTS and the Hub uplink and downlink ports. Not used with a simplex BTS
<b>Connecting Multiple Fusion Wideband Main Hubs Together</b>		
	5-port Alarm Daisy-Chain Cable (PN 4024-3)	For contact alarm monitoring of fault and warning alarms. Used to feed the alarms from multiple Fusion Wideband Main Hubs into a BTS or FlexWave Focus. N.C. Operation.
<b>Cabling</b>		
	Coaxial: repeater, base station, Smart Source to Fusion Wideband Main Hub	Coax approved; N-type male connectors.
	Coaxial: RAU to passive antennas	Use low-loss cable; N male connector; typical 1 m (3.3 ft) using RG142 coaxial cable.
	Fiber: Main Hub to Expansion Hubs	SC/APC (angle-polished) male connectors for entire fiber run (can use SC/APC pigtails, PN 4012SCAPC-10 for MMF or 4013SCAPC-10 for SMF); Use jumper fiber cables for collocated Main and Expansion Hubs (3 m/10 ft.): Multi-mode: PN 4017SCAPC-10 Single-mode: PN 4018SCAPC-10 Distance limited by optical loss of 3 dB Multi-mode up to 500 m (1640 ft.) Single-mode up to 6 km (19,685 ft.)
	CATV	TIA-570-B approved; centerpin F male connectors. CATV connectors must be connected to the shield at both ends. The RAU will be damaged if it is mis-wired. Tie-off cables to avoid damaging the connectors because of cable strain.
	Fusion Wideband Expansion Hub to RAUs	<ul style="list-style-type: none"> <li>• Minimum: 0 meters (0 ft)</li> <li>• Maximum: RG-59: 130 meters (426 ft) *</li> <li style="padding-left: 40px;">RG-6: 140 meters (459 ft)</li> <li style="padding-left: 40px;">RG-11: 235 meters (771 ft)</li> </ul>

**Table 7-2 Installation Checklist (continued)**

✓	Installation Requirement	Consideration
* Refer to Appendix A for CATV cable requirements.		
<b>Configuring the System</b>		
	PC/laptop running standard browser software	Refer to the <i>AdminBrowser User Manual</i> (PN D-620607-0-20)
<b>Miscellaneous</b>		
	Cross-over Ethernet cable	Male connectors; Fusion Wideband Main Hub to a PC/laptop running a standard browser to the Fusion Wideband AdminBrowser software; local connection or LAN switch connector for remote connections.
	Straight-through cable	Female/male connectors; Fusion Wideband Main Hub to a modem for a remote connection.
<b>Distances</b>		
	Fusion Wideband Main Hub is within 3–6m (10–20 ft) of connecting repeater/BTS/Flex-Wave	If longer distance, determine the loss of the cable used for this connection and adjust the RF signal for each Band into the Fusion Wideband Main Hub accordingly. This can be done by readjusting the power from the base station, or by changing the attenuation value between the base station/repeater and the Hub Bands (1 and 2).

### 7.3.3 Tools and Materials Required

**Table 7-3 Tools and Materials Required for Component Installation**

✓	Description
	Cable ties
	Screwdriver
	Mounting screws and spring nuts
	Screws, anchors (for mounting RAUs)
	Drill
	Fiber connector cleaning kit
	Fusion splicer
	Splicing tool kit (including snips, cladding strippers, fiber cleaver, isopropyl alcohol, lint-free wipes)
	Fusion splicing sleeves

### 7.3.4 Optional Accessories

**Table 7-4 Optional Accessories for Component Installation**

✓	Description
	Wall-mount bracket (PN 4712) When using this bracket with an Fusion Wideband Main Hub, the Hub's mounting bracket must be moved to the alternate mounting position (refer to the procedure on page page 7-11).
	Cable management (Cable manager: PN 4759; Tie wrap bar: PN 4757)
	Splice trays
	Pigtails with SC/APC connectors, 3 m (10 ft.) Multi-mode fiber SC/APC pigtail: PN 4012SCAPC-10 Single-mode fiber SC/APC pigtail: PN 4013SCAPC-10
	Jumper cable when Main and Expansion Hubs are collocated, 3 m (10 ft.) Multi-mode fiber SC/APC: PN 4018SCAPC-10
	Teltone Line Sharing Switch (M-394-B-01) When using a single POTS line with multiple Fusion Wideband Main Hub/Modems: Connect up to four modems to a line sharing switch; switches can be cascaded to accommodate up to 16 modems per POTS line
	Alarm Cables: 5-port Alarm Daisy-Chain Cable (PN 4024-3) Alarm Sense Adapter Cable (PN 4025-1)

## **7.4 Fusion Wideband Installation Procedures**

The following procedures assume that the system is new from the factory and that it has not been programmed with bands.

If you are replacing components in a pre-installed system with either new units or units that may already be programmed (for example, re-using units from another system), refer to Section 8.

- Installing a Fusion Wideband Main Hub ..... 7-11
  - Installing a Fusion Wideband Main Hub in a Rack ..... 7-11
  - Using the Wall Rack-Mounting Option ..... 7-13
  - Installing an Optional Cable Manager in the Rack ..... 7-12
  - Installing a Main Hub Using the 12" Wall-Mounted Rack (PN 4712) ... 7-12
  - Installing a Fusion Wideband Main Hub Directly to the Wall ..... 7-14
  - Connecting the Fiber Cables to the Main Hub ..... 7-15
  - Making Power Connections ..... 7-18
  - Powering On the Main Hub ..... 7-23
- Installing Expansion Hubs ..... 7-25
  - Installing an Expansion Hub in a Rack ..... 7-25
  - Installing an Expansion Hub Using the 12" Wall-Mounted Rack ..... 7-26
  - Installing a Fusion Wideband Expansion Hub Directly to the Wall ..... 7-27
  - Installing an Optional Cable Manager in the Rack ..... 7-28
  - Powering On the Expansion Hub ..... 7-28
  - Connecting the Fiber Cables to the Expansion Hub ..... 7-29
  - Connecting the 75 Ohm CATV Cables ..... 7-30
  - Troubleshooting Expansion Hub LEDs During Installation ..... 7-31
- Installing RAUs ..... 7-32
  - Installing RAUs ..... 7-32
  - Installing Passive Antennas ..... 7-32
  - Connecting the Antenna to the RAU ..... 7-34
  - Connecting the CATV Cable ..... 7-34
  - Troubleshooting Using RAU LEDs During Installation ..... 7-35
- Configuring the Fusion Wideband System ..... 7-36
  - Connecting a PC to the Main Hub to Run AdminBrowser ..... 7-36
  - Programming the Main Hub Using AdminBrowser ..... 7-37
- Fusion Splicing of Fiber and Pigtail ..... 7-44



The following procedures assume that the system is installed and programmed.

- Interfacing the Fusion Wideband Main Hub to an RF Source . . . . . 7-46
  - Connecting a Single Fusion Wideband Main Hub to an RF Source . . . . . 7-46
  - Connecting a Fusion Wideband Main Hub to a Roof-top Antenna . . . . . 7-50
  - Connecting Multiple Fusion Wideband Main Hubs to an RF Source . . . . . 7-51
  - Connecting Multiple Wideband Main Hubs to a Duplex Repeater or BTS 7-54
- Connecting Contact Alarms to a Fusion Wideband System . . . . . 7-56
  - Alarm Source . . . . . 7-57
  - Alarm Sense . . . . . 7-60
  - Alarm Cables . . . . . 7-62
- Alarm Monitoring Connectivity Options . . . . . 7-63
  - Direct Connection . . . . . 7-63
  - Modem Connection . . . . . 7-64
  - 100 BASE-T Port Expander Connection . . . . . 7-73
  - POTS Line Sharing Switch Connection . . . . . 7-74
  - Ethernet LAN Connection . . . . . 7-76
  - SNMP Interface . . . . . 7-77

### 7.4.1 Installing a Fusion Wideband Main Hub



**CAUTION:** Install Fusion Wideband Main Hubs in indoor locations only.

---

#### ✓ Installing a Fusion Wideband Main Hub in a Rack

The Fusion Wideband Main Hub (2U high) mounts in a standard 19 in. (483 mm) equipment rack. Allow clearance of 76 mm (3 in.) front and rear, and 51 mm (2 in.) on both sides for air circulation. No top or bottom clearance is required.

**Figure 7-1 Flush Mounting Bracket Detail**

---



**Consideration:**

- The Fusion Wideband Main Hub is shipped with #10-32 mounting screws. Another common rack thread is #12-24. Confirm that the mounting screws match the rack's threads.

**To install the Hub in a rack:**

1. Insert spring nuts into rack where needed or use existing threaded holes.
2. Place the Hub into the rack from the front.
3. Align the flange holes with the spring nuts installed in Step 1.
4. Insert the mounting screws in the appropriate positions in the rack.
5. Tighten the mounting screws.

**✓ Installing an Optional Cable Manager in the Rack**

- Using the screws provided, fasten the cable manager to the rack, immediately above or below the Main Hub.

**✓ Installing a Main Hub Using the 12" Wall-Mounted Rack (PN 4712)**

**Considerations:**

- The rack-mounting brackets on the Fusion Wideband Main Hub must be moved to the recessed mounting position (shown in Figure 7-2) to allow for the required 76 mm (3 in.) rear clearance.
- The maximum weight the bracket can hold is 22.5 kg (50 lbs).
- The bracket is designed to accommodate a Fusion Wideband Main Hub (12 lbs.) or an Expansion Hub (14.5 lbs.).
- The wall mount bracket should be securely mounted to wall, using the four key slot mounting holes on the bracket.

### Using the Wall Rack-Mounting Option

You can flip the rack mounting brackets, as shown in Figure 7-2, so the hub can be mounted 76 mm (3 in.) forward in the rack.

**Figure 7-2 Bracket Detail For Wall Mount Rack (PN 4712)**

---



#### To install the Hub to the wall-mounted rack:

1. Attach the wall bracket (PN 4712) to wall the using #10 Pan Head wood screws, 1-1/2" minimum length for mounting in wood studs or 3/4" thick plywood.

The bracket must be positioned so that the Hub will be in a horizontal position when it is installed. (Refer to Figure 7-2.)

---

**NOTE:** If wall stud spacing of 16" is not available, ADC recommends that 3/4" plywood be pre-installed to the wall. You can then attach the bracket to the plywood using the wood screws.

---

2. Remove both of the rack mounting brackets from the Hub.
3. Reattach each of the rack mounting brackets to the recessed wall mount position.

4. Install the Hub in the rack using the rack mounting screws.

### ✓ Installing a Fusion Wideband Main Hub Directly to the Wall

#### To install the Hub directly to the wall:

1. Pre-install 3/4" plywood to the wall.
2. Mount both of the rack mounting brackets using #10-32 machine screws (refer to illustration Figure 7-4).
3. Attach the Hub to the wall so the mounting brackets are orientated at the top and bottom of the wall mounted hub. (Refer to Figure 7-3.)

**Figure 7-3 Installing Directly to the Wall**

---



Use two #10 Pan Head wood screws, 1-1/2" length, to secure each bracket to the plywood. In this orientation the enclosure fans shall face to the left.

**Figure 7-4 Using Hub Rack-Mounting Brackets for Direct Wall Installation**



### ✓ Connecting the Fiber Cables to the Main Hub

#### Considerations:

- Before connecting the fiber cables, confirm that their optical loss does not exceed the 3 dB optical budget.
- If you are using fiber distribution panels, confirm that the total optical loss of fiber cable, from the Main Hub through distribution panels and patch cords to the Expansion Hub, does not exceed the optical budget.
- Make sure the fiber cable's connectors are SC/APC (angle-polished). Using any other connector type will result in degraded system performance and may damage the equipment. (You can use an SC/APC pigtail if the fiber cable's connectors are not SC/APC. Refer to "Fusion Splicing of Fiber and Pigtail" on page 7-44. Or, you can change the fiber's connector to SC/APC.)

---

**NOTE:** Observe all Fiber Port Safety Precautions listed in Section 7.2.3 on page 7-4.

---

**To clean the fiber ports:**

You can clean the Hub's fiber ports using canned compressed air or isopropyl alcohol and foam tipped swabs.

**Considerations:**

- If using compressed air:
  - The air must be free of dust, water, and oil.
  - Hold the can level during use.
- If using isopropyl alcohol and foam tipped swabs:
  - Use only 98% pure or more alcohol

**Procedure using compressed air:**

1. Remove the port's dust cap.
2. Spray the compressed air away from the unit for a few seconds to clean out the nozzle and then blow dust particles out of each fiber port.

**Procedure using isopropyl alcohol:**

1. Remove the connector's dust cap.
2. Dip a 2.5mm lint-free, foam-tipped swab in isopropyl alcohol and slowly insert the tip into the connector.
3. Gently twist the swab to clean the port.
4. Insert a dry swab into the port to dry it.

Additionally, you can use compressed air after the alcohol has completely evaporated.

**To clean the fiber ends:**

Be sure that the fiber cable's SC/APC connectors are clean and free of dust and oils. You need lint-free cloths, isopropyl alcohol, and compressed air

1. Moisten a lint-free cloth with isopropyl alcohol.
2. Gently wipe the fiber end with the moistened cloth.
3. Using a dry lint-free cloth, gently wipe the fiber end.
4. Spray the compressed air away from the connector for a few seconds to clean out the nozzle and then use it to completely dry the connector.

**To test the fiber cables:**

Perform cable testing and record the results. Test results are required for the final As-Built Document.

**To connect the fiber cables:**

The fiber cable is labeled with either **1** or **2**, or is color-coded. In addition to these labels, you should add a code that identifies which port on the Main Hub is being

used and which Expansion Hub the cables are intended for. This differentiates the connectors for proper connection between the Main Hub and Expansion Hubs.

For example:

First pair to Main Hub port 1: 11 (uplink), 12 (downlink);

Second pair to Main Hub port 2: 21 (uplink), 22 (downlink);

Third pair to Main Hub port 3: 31 (uplink), 32 (downlink); and so on.

---

**NOTE:** The Fusion Wideband One Port Main Hub (PN: FSN-W1-MH-1P) configuration is a cost reduced version of the Fusion Wideband Main Hub and supports *only* one Expansion Hub (up to 8 RAUs).

---

If the fiber jumper is labeled with **1** or **2**:

1. Connect **1s** to **UPLINK** ports on the Main Hub.
2. Connect **2s** to **DOWNLINK** ports on the Main Hub.
3. Record which cable number and port number you connected to **UPLINK** and **DOWNLINK**.

This information is needed when connecting the other end of the fiber cable to the Expansion Hub's fiber ports.

The fiber port LEDs should be off, indicating that the Expansion Hub(s) are not connected.

If the fiber jumper is color-coded (for example, "blue" or "red"):

1. Connect "blue" to **UPLINK** ports on the Main Hub.
2. Connect "red" to **DOWNLINK** ports on the Main Hub.
3. Record which color and port number you connected to **UPLINK** and **DOWNLINK**.

This information is needed when connecting the other end of the fiber cable to the Expansion Hub's fiber ports.

The fiber port LEDs should be off, indicating that the Expansion Hub(s) are not connected.

## ✓ Making Power Connections

Only trained and qualified personnel should be allowed to install or replace this equipment.

### AC Powered Main Hub

To connect AC power to a Main Hub:

1. Connect the AC power cord to the Main Hub.
2. Plug the power cord into an AC power outlet.

### DC Powered Main Hub and Expansion Hub



**WARNING:** The protective earth connection should be connected before proceeding with power connections. Confirm the DC power source is powered off during installation. Damage to hubs may result if power is connected improperly.

---

The DC powered Main Hub and Expansion Hub are intended to be powered by a +48VDC power source. The hubs are designed for 14AWG to 6AWG wire size connections. Use only UL listed AWM wire, rated 600V and 90 degrees C.

If wires larger than 6AWG are needed from the DC power source, follow local codes for reducing the wire size at hub connection point.

Follow local codes for routing of power cables to power source.

The unit should be connected to a DC branch circuit breaker. A suitable disconnect device must be provided in the DC branch, either a circuit breaker or switch, that can be employed to disconnect power to the system during servicing.

To connect DC power to a Main Hub or Expansion Hub:

1. Strip 5/8" (16mm) of wire insulation material off each power wire.
2. Insert the +48VDC wire into the compression terminal at the "+" location.
3. Insert the -48VDC wire into the compression terminal at the "-" location.
4. Bare wire ends should be fully inserted into terminal.
5. Use a flat blade screw driver to fasten the wire inside the compression terminal.
6. For the Protective Ground Wire (Figure 7-5), use 14AWG minimum wire with a #8-32 stud size ring lug.

**Figure 7-5 Protective Ground Wire Connection**

---





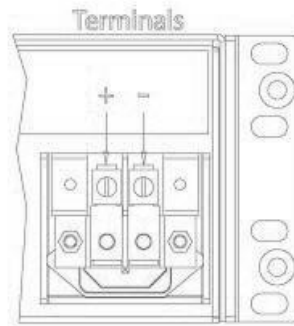


**WARNING:** The warning color code of the power cables depends on the color coding of the DC power source installed at your site. Color code standards for DC wiring do not exist. To ensure that the correct polarity is connected to the hubs, confirm the connection of the power cables to the + (positive) and - (negative) leads (Figure 7-6) at the power source.

---

Figure 7-6 DC Terminals

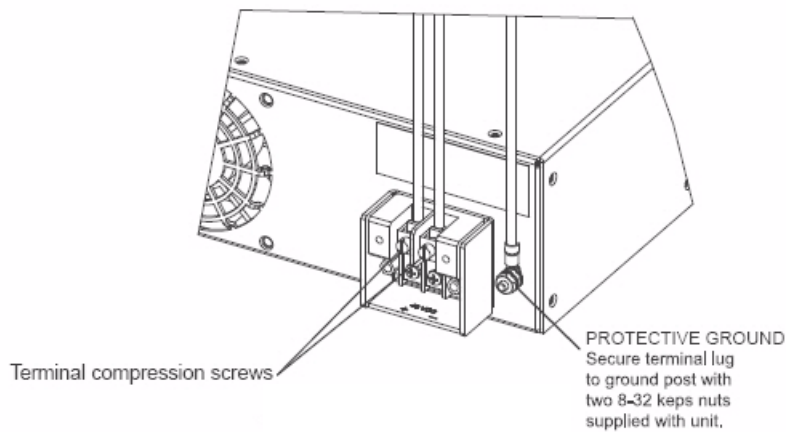
---



7. Use the illustrations in Figure 7-7 and Figure 7-9 to connect the power.

Figure 7-7 Power Screw Locations

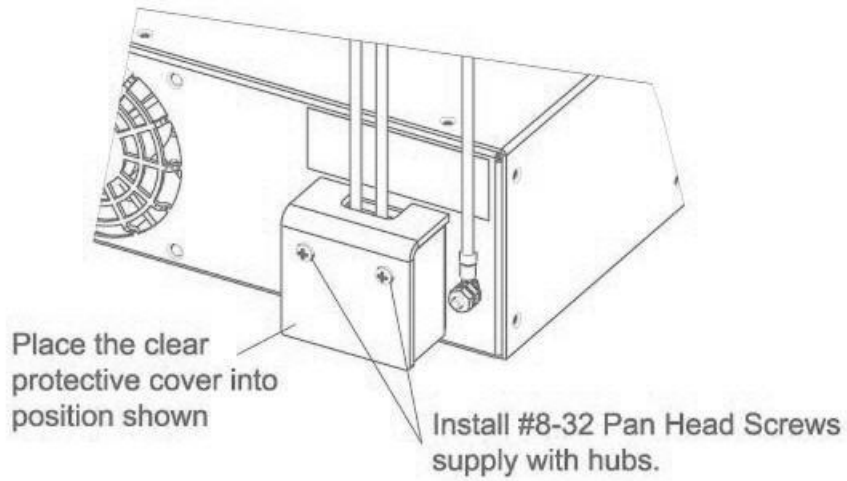
---



8. Install the clear protective cover with the pan head screws as shown in Figure 7-8.

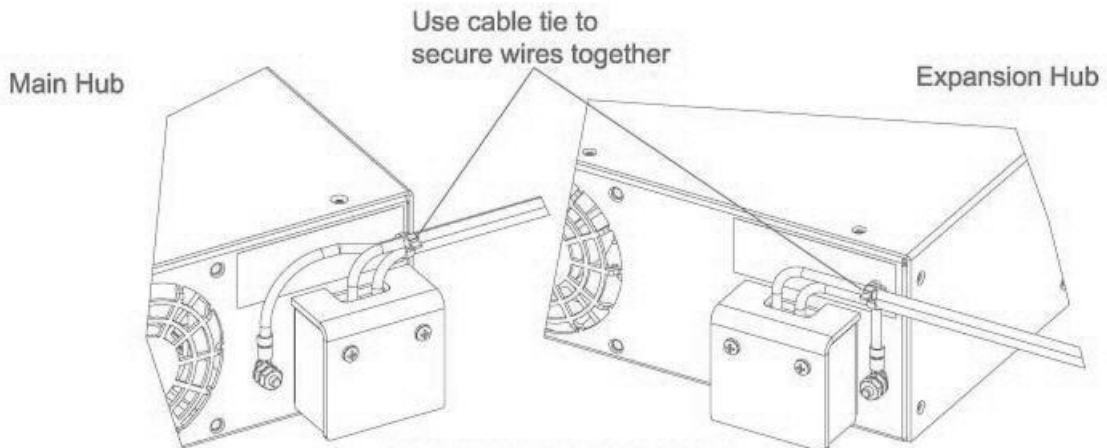
**Figure 7-8 Pan Head Screw Location**

---



**Figure 7-9 Recommended Hub Wire Routing**

---



### Optional Connection to DC Power Source

This is an optional connection method using ring tongue lugs instead of the compression lugs that are premounted on the terminal block. Use wire selection instructions previously explained.

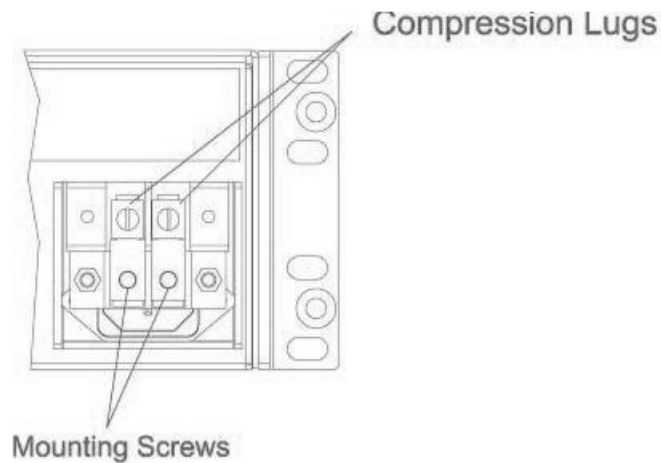


**WARNING:** Before connecting power wires, be sure the power source is shut off, and the power switch of the hubs are in the OFF position. Connect the ground wires before connecting the power wires.

1. Remove the existing compression lugs by first removing the mounting screws as shown in Figure 7-10.

**Figure 7-10** Compression Lug and Mounting Screw Locations

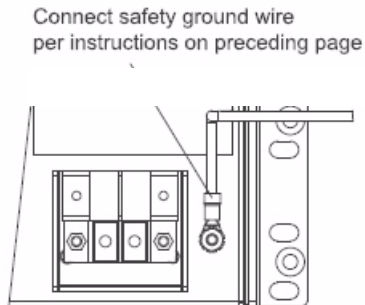
---



2. Connect the safety ground wire as previously explained and shown in Figure 7-11. Use 14AWG minimum wire with a #8-32 stud size ring lug as shown in Figure 7-12.

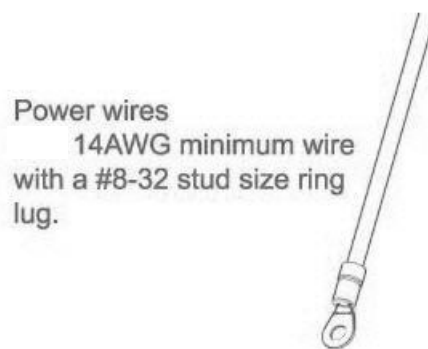
**Figure 7-11 Grounding Wire Connection**

---



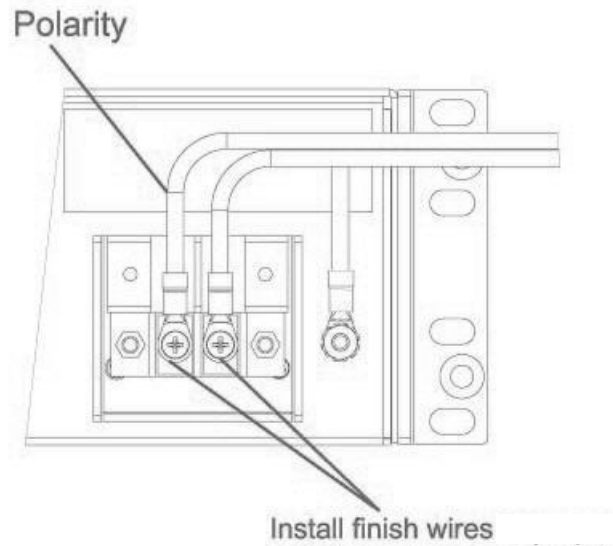
**Figure 7-12 Power Wires and Studs**

---



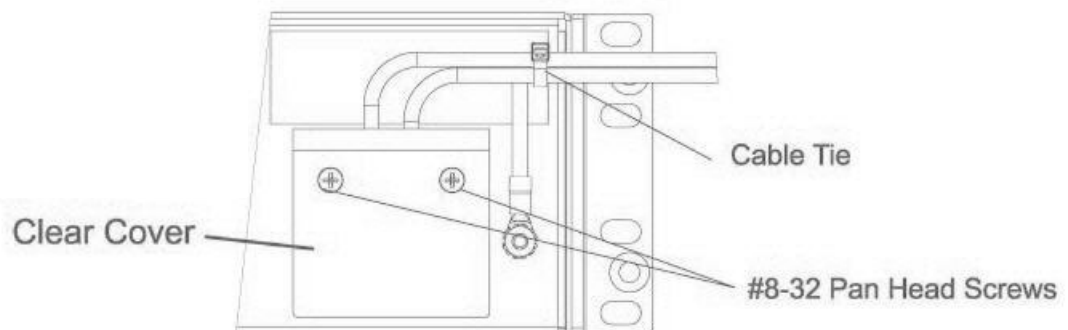
3. Install the finish wires using the proper polarity and secure them with #8-32 pan head screws previously removed as illustrated in Figure 7-13.

Figure 7-13 Wire Polarity Illustration



4. Attach the clear protective cover and secure it with the two #8-32 pan head screws supplied with the Hub as shown in Figure 7-14.

Figure 7-14 DC Illustration Detail



### ✓ Powering On the Main Hub

1. Connect the AC or DC power as explained in “Making Power Connections” on page 7-18.
2. Turn on the power to the Main Hub and check that all the LED lamps are functioning properly.

Upon power-up, the LEDs blinks for five seconds as a visual check that they are functioning. After the five-second test:

LED states during power on will vary, depending on whether Expansion Hubs are connected. Refer to Table 7-5 for possible combinations.

**Table 7-5 Troubleshooting Main Hub LEDs During Installation**

During Installation Power On	LED	State	Action	Impact
1. Main Hub power is On with no Expansion Hubs connected.	POWER	Off	Check AC power; check that the Main Hub power-on switch is on; replace the Main Hub	The Main Hub is not powering on.
	POWER	Red	Replace the Main Hub	The power supply is out-of-specification.
	PORT	LEDs are on but they didn't blink through all states	Replace the Main Hub.	The micro controller is not resetting properly; flash memory corrupted.
	PORT	Red Off	The port is unusable; replace the Main Hub when possible.	Fiber sensor fault, do not use the port.
2. Main Hub power is On with Expansion Hubs connected and powered on.	PORT	Off	<ul style="list-style-type: none"> <li>If the port LEDs do not illuminate, check the fiber uplink for excessive optical loss.</li> <li>If Expansion Hub's <b>DL STATUS</b> LED is red:                             <ul style="list-style-type: none"> <li>Verify that the fiber is connected to the correct port (that is, uplink/downlink)</li> <li>Swap the uplink and downlink cables.</li> </ul> </li> <li>Connect the fiber pair to another port. If the second port's LEDs do not illuminate Green/Red, replace the Main Hub.</li> <li>If the second port works, flag the first port as unusable; replace the Main Hub when possible.</li> </ul>	No uplink optical power, the Expansion Hub is not recognized as being present.  No communication with the Expansion Hub.
	PORT	Red (60 ppm)	<ul style="list-style-type: none"> <li>If the Expansion Hub <b>DL STATUS</b> LED is red, check the downlink fiber cable for excessive optical loss.</li> <li>Connect the fiber pair to another port. If the second port's LEDs do not illuminate Green/Red, replace the Main Hub.</li> <li>If the second port works, flag the first port as unusable; replace the Main Hub when possible.</li> </ul>	No communication with the Expansion Hub.
	PORT	Red	The Expansion Hub or connected RAU reports a fault Use AdminManager to determine the problem.	The Expansion Hub or one or more RAUs are off-line.

## 7.4.2 Installing Expansion Hubs

The Expansion Hub (2U high) can be installed in a standard 19 in. (483 mm) equipment rack or in a wall-mountable equipment rack that is available from ADC. Allow a clearance of 76 mm (3 in.) front and rear and 51 mm (2 in.) sides for air circulation. No top and bottom clearance is required.



**CAUTION:** Install Expansion Hubs in indoor locations only.

### ✓ Installing an Expansion Hub in a Rack

#### Consideration:

- The Expansion Hub is shipped with #10-32 mounting screws. Another common rack thread is #12-24. Confirm that the mounting screws match the rack's threads.

**Figure 7-15 Flush Mounting Bracket Detail**



#### To install the hub in a rack:

1. Insert spring nuts into the rack where needed or use existing threaded holes.
2. Place the Expansion Hub into the rack from the front.
3. Align the flange holes with the spring nuts installed in Step 1.
4. Insert the mounting screws in the appropriate positions in the rack.
5. Tighten the mounting screws.

## ✓ Installing an Expansion Hub Using the 12" Wall-Mounted Rack

### Considerations:

- The rack (PN4712) is 305 mm (12 in.) deep. The Expansion Hub is 381 mm (15 in.) deep. You must move the rack mounting brackets on the Expansion Hub, as shown in Figure 7-16) to the center mounting position to allow for the 76 mm (3 in.) rear clearance that is required.
- The maximum weight the rack can hold is 22.5 kg (50 lbs).

**Figure 7-16 Bracket Detail For Wall Mount Rack (PN 4712)**

---



### To install the hub in a wall-mounted rack:

1. Attach the equipment rack to the wall using the screws that are provided.  
The rack must be positioned so that the Expansion Hub will be in a horizontal position when it is installed.

---

**NOTE:** If wall stud spacing of 16" is not available, ADC recommends that 3/4" plywood be pre-installed to the wall. You can then attach the bracket to the plywood using the wood screws.

---

2. Remove both of the rack mounting brackets from the Hub.
3. Reattach each of the rack mounting brackets to the recessed wall mount position (Figure 7-16).
4. Install the Hub in the rack using the rack mounting screws.
5. Tighten the mounting screws.



**✓ Installing a Fusion Wideband Expansion Hub Directly to the Wall**

**To install the Hub directly to the wall:**

1. Pre-install 3/4" plywood to the wall.
2. Mount both of the rack mounting brackets using #10-32 machine screws (refer to illustration Figure 7-17).
3. Attach the Hub to the wall so the mounting brackets are orientated at the top and bottom of the wall mounted hub. (Refer to Figure 7-18.)

**Figure 7-17 Using Hub Rack-Mounting Brackets for Direct Wall Installation**

---



**Figure 7-18** Installing Directly to the Wall

---



---

**NOTE:** Leave the dust caps on the fiber ports until you are ready to connect the fiber optic cables.

---

**✓ Installing an Optional Cable Manager in the Rack**

- Using the screws provided, fasten the cable manager to the rack, immediately above or below the Expansion Hub.

**✓ Powering On the Expansion Hub**

1. Connect the AC or DC power as explained in “Making Power Connections” on page 7-18.

2. Turn on the power to the Expansion Hub and check that all the LED lamps are functioning properly.

Upon power-up, the LEDs blink for five seconds as a visual check that they are functioning. After the five-second test:

- The **POWER** and **UL STATUS** LEDs should be green.
  - If the uplink fiber is not connected, the **UL STATUS** LED turns red indicating that there is no communication with the Main Hub.
- The **E-HUB STATUS** and **DL STATUS** LEDs should be red.
- All port LEDs should be off because no RAUs are connected yet.

## ✓ Connecting the Fiber Cables to the Expansion Hub

### Considerations:

- Before connecting the fiber cables, confirm that their optical loss does not exceed 3 dB optical budget. RL is less than -60dB.
- If fiber distribution panels are used, confirm that the total optical loss of fiber cable, from the Main Hub through distribution panels and patch cords to the Expansion Hub, does not exceed the optical budget.
- Make sure the fiber cable's connectors are SC/APC (angle-polished). Using any other connector type will result in degraded system performance and may damage the equipment. (You can use an SC/APC pigtail if the fiber cable's connectors are not SC/APC, refer to "Fusion Splicing of Fiber and Pigtail" on page 7-44, or replace the connectors.)

---

**NOTE:** Observe all Fiber Port Safety Precautions listed in Section 7.2.3 on page 7-4.

---

### To connect the fiber cables:

The fiber cable is labeled with either **1** or **2**, or is color-coded. For proper connection between the Main Hub ports and the Expansion Hub ports, refer to the numbering or color-coded connections you recorded when installing the Main Hub(s).

If the fiber jumper is labeled with **1** or **2**:

1. Connect **2** to **DOWNLINK** on Expansion Hub.

The **DL STATUS** LED should turn green as soon as you connect the fiber. If it does not, there is a downlink problem. Make sure you are connecting the correct cable to the port.

2. Connect **1** to **UPLINK** on Expansion Hub.

The **UL STATUS** LED turns green on the first Main Hub communication. It may take up to 20 seconds to establish communication.

The Expansion Hub's **E-HUB STATUS** LED turns green when the Main Hub sends it the frequency band command.

If the **UL STATUS** and **E-HUB STATUS** LEDs do not turn green/green, check the Main Hub LEDs. Refer to page 7-24, item 2 in Table 7-5.

If the fiber jumper is color-coded (for example, “blue” or “red”):

1. Connect “red” to **DOWNLINK** on Expansion Hub.

The **DL STATUS** LED should turn green as soon as you connect the fiber. If it does not, there is a downlink problem. Make sure you are connecting the correct cable to the port.

2. Connect “blue” to **UPLINK** on Expansion Hub.

The **UL STATUS** LED turns green on the first Main Hub communication. It may take up to 20 seconds to establish communication.

The Expansion Hub’s **E-HUB STATUS** LED turns green when the Main Hub sends it the frequency band command.

If the **UL STATUS** and **E-HUB STATUS** LEDs do not turn green/green, check the Main Hub LEDs. See page 7-24, item 2 in Table 7-5.

## **Connecting the 75 Ohm CATV Cables**

### **Considerations:**

- Verify that the cable has been tested and the test results are recorded. This information is required for the As-Built Document.
- Verify that only captive centerpin F connectors are used on the solid copper center conductor CATV cable from CommScope (or equivalent).
- Verify that the CATV cable is labeled with:
  - Fusion Wideband Expansion Hub port number being used
  - RAU identifier
  - Carrier (for multiple operator systems)

### **To connect the CATV cables:**

1. Connect the CATV cables to the F ports according to the labels on the cables.

The **STATUS** LEDs should be off because the RAUs are not connected at the other end of the CATV cable.

2. Record which cable you are connecting to which port (that is, from the label on the cable).

This information is required for the As-Built Document.

3. Tie-off the cables or use the optional cable manager to avoid damaging the connectors because of cable strain.

 **Troubleshooting Expansion Hub LEDs During Installation**

- All Expansion Hub **PORT** LEDs with RAUs connected should indicate Green/Red. This indicates that the RAU is powered on and communication has been established.
- The Expansion Hub **UL STATUS** LED should be Green.

**Table 7-6 Troubleshooting Expansion Hub LEDs During Installation**

<b>During Installation</b>	<b>LED</b>	<b>State</b>	<b>Action</b>	<b>Impact</b>
1. Expansion Hub power is On and no RAUs are connected	<b>POWER</b>	Off	Check AC power; make sure the Expansion Hub power-on switch is on; replace the Expansion Hub.	The Expansion Hub is not powering on.
	<b>PORT</b>	LEDs are on but didn't blink through all states.	Replace the Expansion Hub.	The Microcontroller is not resetting properly; flash memory corrupted.
	<b>PORT</b>	Flashing Red (6 PPM)	Port unusable; replace the Expansion Hub when possible.	Current sensor fault; do not use the port.
	<b>UL STATUS</b>	Red, after power-up blink	Replace the Expansion Hub.	The Expansion Hub laser is not operational; no uplink between the Expansion Hub and Main Hub.
	<b>UL STATUS</b>	Red	Check the Main Hub LEDs Refer to page 7-24, item 2 in Table 7-5. Use AdminBrowser to determine the problem.	No communication with Main Hub.
	<b>DL STATUS</b>	Red	Check the downlink fiber for optical power; verify that the cables are connected to correct ports (that is, uplink/downlink) Check the Main Hub LEDs. Refer to page 7-24, item 2 in Table 7-5.	No downlink between the Expansion Hub and Main Hub.
2. Expansion Hub power is On and RAUs are connected	<b>PORT</b>	Off	Check the CATV cable.	Power is not getting to the RAU.
	<b>PORT</b>	Flashing Red (60 PPM)	Test the CATV cable. If the cable tests OK, try another port. If the second port's LEDs are Red/Off, replace the RAU. If the second RAU doesn't work; replace the Expansion Hub.	Power levels to RAU are not correct; communications are not established. If the second port works, flag the first port as unusable; replace EH when possible.
	<b>PORT</b>	Red	Use AdminBrowser to determine the problem.	RAU is off-line.

### 7.4.3 Installing RAUs



**CAUTION:** Install RAUs in indoor locations only. Do not connect an antenna that is installed in an outdoor location to an RAU. For outdoor installations, a protective enclosure is required.

---

#### ✓ Installing RAUs

Mount all RAUs in the locations marked on the floor plans.

##### Considerations:

- You can place the unit, without its fastening hardware, on a flat surface, such as a shelf, desk, cabinet, or any other horizontal surface that allows stable placement with the mounting base facing down to the mounting surface. For mounting to other locations (that is, walls, ceilings, poles) the RAU must be securely mounted using the 4 slotted mounting holes provided with #6 diameter fasteners. This method of mounting must securely hold a minimum of 7 lbs. load.
- Attach the RAU securely to a stationary object (that is, a wall, pole, or ceiling tile).
- For proper ventilation:
  - Keep at least 76 mm (3 in.) clearance around the RAU to ensure proper venting.
  - Do not stack RAUs on top of each other.
  - Always mount the RAU with the solid face (containing the mounting holes) against the mounting surface.
- For the 800/850/1900 MHz RAU (P/N: FSN-W2-808519-1), make sure the 800 MHz iDEN antenna and the 850/1900 MHz antenna are separated by enough space to reduce signal interference between the 800 and 850 MHz bands. Refer to “800/850 MHz Isolation Requirements” on page 7-33 for the recommended distance between antennas.

#### ✓ Installing Passive Antennas

Refer to the manufacturer’s installation instructions to install passive antennas.

##### Location

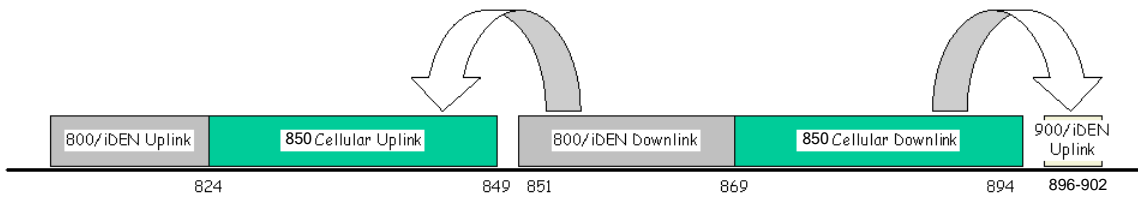
Passive antennas are usually installed below the ceiling. If they are installed above the ceiling, you must consider the additional loss due to the ceiling material when estimating the antenna coverage area.

### 800/850 MHz Isolation Requirements

When deploying any RF system, give special attention to preventing receiver blocking or desensitization by out-of-band transmitters. Typically, sharp filters in the receiver front-end will reduce the interfering transmitters to tolerable levels. In select cases, the interferers may occupy a frequency band that is directly adjacent to the receiving band and cannot be adequately rejected by filtering. The only recourse in these situations is to provide sufficient isolation by physically separating the interfering transmitters and receivers.

iDEN occupies spectrum at both 800 MHz and 900 MHz (Tx:851–869/Rx:806–824 and Tx:935–941 /Rx:896–902), while the Cellular A and B carriers share a single 850 MHz block (Tx:869–894/Rx:824–849). The combination of these frequency bands, 800/900 MHz iDEN and 850 MHz Cellular, result in uplink (BTS receive) bands that are adjacent to downlink (BTS transmit) bands. Figure 7-19 depicts these nearly contiguous bands, with arrows indicating the interfering downlink and receiving uplink bands.

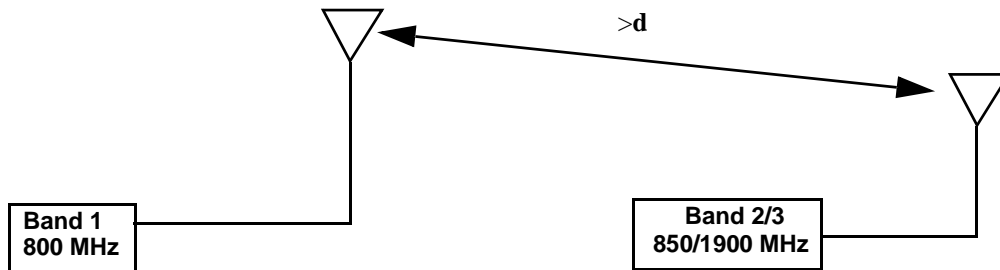
Figure 7-19 800/850 MHz Spectrum



Installation of an in-building distributed antenna system (DAS) to provide coverage for both 800/900 MHz iDEN and 850 MHz Cellular must account for these downlink-to-uplink interference issues and provide adequate isolation.

ADC offers the following guidelines toward achieving the proper amount of isolation when deploying ADC Fusion DAS products.

Figure 7-20 Fusion Wideband 800/850/1900 MHz RAU Antenna Placement Guideline



### **800 MHz iDEN Downlink and 850 MHz Cellular Uplink**

A 2 MHz frequency gap (851 – 849 MHz) separates the 800 iDEN downlink and 850 Cellular uplink frequency bands. Because of this narrow spacing, 800 iDEN downlink intermodulation products may fall within the 850 Cellular uplink band. In addition, 800 iDEN downlink signals near the lower edge of the band at 851 MHz may cause the 850 Cellular uplink automatic level control (ALC) circuitry in the RAU to engage and thereby reduce uplink gain.

To prevent either of these conditions, use the following guidelines:

- In-band 800 iDEN intermodulation products < -90dBm
- Lower frequency 800 iDEN signals < -30dBm for Fusion

Given a typical DAS configuration (4 iDEN carriers, omni-directional antennas, line of sight), these guidelines translate to an antenna spacing (d) of 6 – 9 meters.

### **850 MHz Cellular Downlink and 900 MHz iDEN Uplink**

A 2 MHz frequency gap (896 – 894 MHz) separates the 850 Cellular downlink and 900 iDEN uplink frequency bands. Because of this narrow spacing, 850 Cellular downlink intermodulation products may fall within the 900 iDEN uplink band. In addition, 850 Cellular downlink signals near the upper edge of the band at 894 MHz may cause the 900 iDEN uplink ALC to engage and thereby reduce uplink gain.

To prevent either of these conditions, use the following guidelines:

- In-band 850 Cellular intermodulation products < -90dBm
- Upper frequency 850 Cellular signals < -30dBm for Fusion

Given a typical DAS configuration (6 CDMA carriers for Fusion, omni-directional antennas, line of sight), these guidelines translate to an antenna spacing (d) of 8-14 meters.

## **Connecting the Antenna to the RAU**

Connect a passive multi-band antenna to the N connector on the RAU using coaxial cable with the least amount of loss possible.



**CAUTION:** Firmly hand-tighten the N connector – DO NOT over-tighten the connector.

---

## **Connecting the CATV Cable**

### **Considerations:**

- Verify that the cable has been tested and the test results are recorded. This information is required for the As-Built Document.



- Verify that only captive centerpin 75 Ohm Type-F connectors are used on the solid copper center conductor CATV 75 Ohm cable.
- Verify that the CATV cable is labeled with:
  - Fusion Wideband Main Hub port number being used
  - RAU identifier
  - Carrier (for multiple operator systems)

**To connect the CATV cable:**

1. Connect the CATV cables to the F female port on the RAU according to the label on the cable.

Power is supplied by the Fusion Wideband Main Hub over the CATV cable conductors. Upon power up, the LEDs will blink for two seconds as a visual check that they are functioning. After the two-second test:

- The **LINK** LED should be green indicating it is receiving power and communications from the Fusion Wideband Main Hub.
  - The **ALARM** LED should be red until the Fusion Wideband Main Hub issues the band command, within about 20 seconds, then it should be green.
2. Record which cable you are connecting to the RAU (from the label on the cable). This information is required for the As-Built Document.
  3. Tie-off cables or use the optional cable manager to avoid damaging the connectors because of cable strain.

#### **7.4.3.1 Troubleshooting Using RAU LEDs During Installation**

- The **LINK** LED should be green and remain green for longer than 90 seconds. The **ALARM** LEDs are red when the system band has not been programmed.

**Table 7-7 Troubleshooting RAU LEDs During Installation**

<b>During Installation</b>	<b>LED</b>	<b>State</b>	<b>Action</b>	<b>Impact</b>
The RAU is connected to the Fusion Wideband Expansion Hub, which is powered on	<b>LINK</b>	Off	Check CATV cable.	No power to the RAU.
	<b>ALARM</b>	Off		
	<b>LINK</b>	Green	<ul style="list-style-type: none"> <li>• Check CATV cable</li> <li>• Check Hub LEDs</li> </ul> Refer to page 7-31, item 2 in Table 7-6.	The RAU is off-line.
	<b>ALARM</b>	Red		
	<b>LINK</b>	Red from green, after cables are connected for 60 seconds	<ul style="list-style-type: none"> <li>• Check CATV cable.</li> <li>• Check the Hub LEDs.</li> <li>• Use AdminBrowser to determine the problem.</li> </ul>	No communications between the RAU and the Hub.
	<b>ALARM</b>	Red		

#### 7.4.4 Configuring the Fusion Wideband System

Before the system can operate properly, use AdminBrowser to program the Fusion Wideband Main Hub with the frequency bands that are to be distributed. The Hub must be programmed with the same frequencies as the RAU used.

**NOTE:** The frequency bands should automatically be set on power up and this step should not be required.

##### Considerations:

- The AdminBrowser software, described in the *AdminBrowser User Manual* (PN D-620607-0-20), must be running on a PC/laptop.
- Crossover Ethernet cable with male connectors required.

#### Connecting a PC to the Main Hub to Run AdminBrowser

1. Connect the AC power cord to the Hub.

**Make sure the Hub is grounded through the ground lug on the AC power and the frame ground lug as required. The warranty does not cover damage caused when an ungrounded Hub is powered on.**

2. Plug the power cord into an AC power outlet.
3. Verify that all cables are properly connected on the Hub.
4. Turn on the power to the Hub.

All LEDs blink through the power up sequence. At each port where an RAU is detected (drawing current), the port LEDs lights green. The Fusion Wideband **STATUS LED** is orange during system boot and should turn green after about 90 seconds if it finds no faults. This state indicates the band's are not programmed and provides feedback on the status of the RAU connections.

The LEDs blink for 20 seconds as a visual check that they are functioning.

5. Connect the cross-over Ethernet cable to the PC/laptop and then to the **RJ-45 100-BASE-T** port on the Hub's front panel.

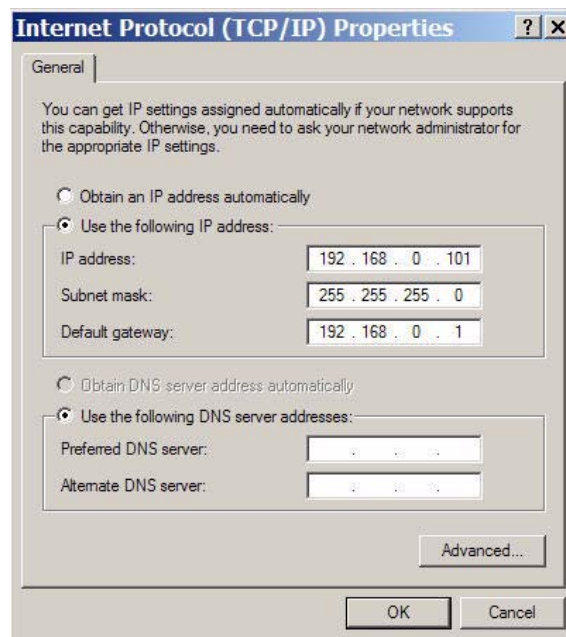
### ✓ Programming the Main Hub Using AdminBrowser

- Connect the provided TCP/IP crossover cable to the laptop and then to the Admin/LAN **RJ-45** port on the Fusion Wideband Main Hub's front panel.
- Turn on the laptop and start the Fusion Wideband Main Hub.

#### Windows 2000

1. Right-click **My Network Places** and select **Properties**.
2. Highlight **Internet Protocol (TCP/IP)** and click **Properties**. A window similar to the Figure 7-21 appears.

**Figure 7-21 Internet Protocol (TCP/IP) Properties Window**



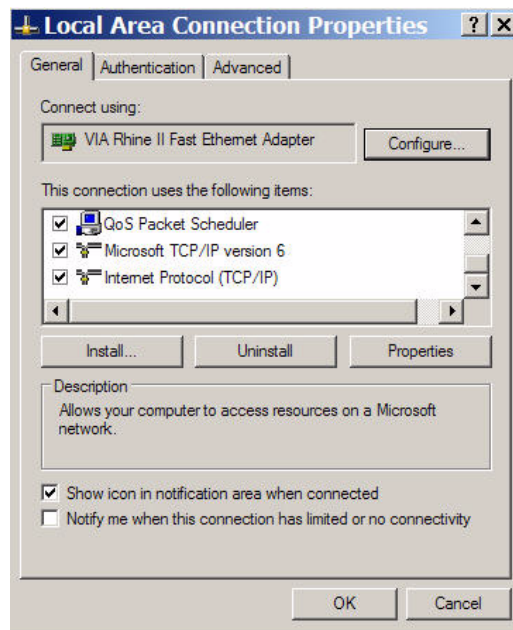
3. Make note of the current IP address, Subnet mask, and Default gateway, if they are configured. You will need to re-enter them after you have configured the Fusion Wideband Main Hub.
4. Select **Use the following IP address**.
5. Change the **IP address** to 192.168.0.101
6. Change the **Subnet mask** to 255.255.255.0
7. Change the **Default gateway** to 192.168.0.1
8. Click **OK** twice. You may be asked if you want to reboot your computer. If so, click **Yes**.

### Windows XP

1. Click **Start>Settings>Network Connections>Local Area Connection**. The window shown in Figure 7-22 appears.

**Figure 7-22 Local Area Connection Properties Window**

---



2. In the **This connection uses the following items**, scroll down to and select **Internet Protocol (TCP/IP)** and click **Properties**.
3. Perform steps 3 through 8 in the preceding section.

## Using AdminBrowser

To access Fusion Wideband using AdminBrowser, use the following steps:

1. Make sure the Main Hub “Status” LED is green.
2. Launch your web browser, type `Https://192.168.0.100` in the URL line, and click **Go**.
3. When AdminBrowser appears, log in using the default user ID: **operator**, and the default password: **password**.
4. Click System Configuration and then click Set Date/Time. A window similar to Figure 7-23 appears.

Figure 7-23 Set Time and Date Window

Old System Date and Time  
Date 04/25/2006  
Time 13:40:54

New System Date and Time  
Date 04/25/2006 (MM/DD/YYYY)  
Time 13:40:54 (hh:mm:ss)

Set Date/Time

5. Enter the desired time and date in the format indicated in the window and click **Set Date/Time**. A window appears requiring you to reboot the system for the new date and time to take effect.
6. Select the Fusion Wideband Main Hub and click **Install/Configure System**. A window similar to the Figure 7-24 appears.

Figure 7-24 AdminBrowser Configuration Window

---

The screenshot shows the AdminBrowser Configuration Window with the following fields and values:

- Label:** FUSION\_WIDEBAND
- System Date and Time:**
  - Date:** 04/04/2007
  - Time:** 22:02:40
- Schedule System Test:**
  - Warning:** A system test will take the system offline.
  - Enable:**
  - System test on power up:**
  - Date:** 04/05/2007 (MM/DD/YYYY)
  - Time:** 00:00:00 (hh:mm:ss)
  - Recurrence:**  Day(s) (1-30) 1,  Week(s) (1-4) 1

7. If desired, type in a label.

The label is the system name displayed next to the icons and used in messages. It can be up to 32 characters long depending upon the firmware version.

The default system label is “Fusion” and will be used if you enter nothing.

8. Use the next section to schedule a System Test.

This section allows you to do the following:

- Click the check box to enable this feature.
- Click the check box to cause system test on power up.

---

**NOTE:** System test will always be run on power up when this box is checked, even if a scheduled system is not enabled.

---

- Enter values to schedule the date and time of the next system test.
- Enter values to specify the recurrence of the test by day or by week.

Schedule System Test allows periodic, automatic execution of the system end-to-end test. Just like Perform System Test, a Schedule System Test suspends normal service for the duration of the test; calls are dropped, and no new calls can be established during the test. Test duration depends on the configuration (number of RAUs) and requires one or two minutes to complete.

After completion of the system test, the scheduled system test time is updated to the next test time.

9. Use the scroll bar on the left side of the page to scroll down to view the rest of the page as shown in Figure 7-25 (Non-WiMAX Installations) and Figure 7-26 (WiMAX Installations only).

Figure 7-25 AdminBrowser Configuration Window for Non WiMAX

The screenshot shows the 'Bands' configuration window. At the top, there is a dropdown menu set to '2100+1800'. Below this, there are two columns for 'Band 1: 2100MHz' and 'Band 2: 1800MHz'. For each band, there are controls for 'Shutdown' (checkbox), 'Uplink Gain' (dropdown set to 0), 'Downlink Gain' (dropdown set to 0), and 'Uplink Automatic Level Control' (dropdown set to Multiple).

10. In the Band area, do the following:

- You should not have to select the bands. The system self configures the band by validating that all the RAUs connected are the same type.
- When both bands are not configured, use the Shutdown check box. The system ignores any alarms generated from the shutdown bands.
- Use the pull-down to specify the Uplink and Downlink gain for each band. You can set system gain within the specified range in 1 dB increments.
- Use the pull-down to set the Uplink Automatic Level Control to either “Single” or “Multiple” for each band in the system. (The default is “Multiple.”)

11. **FOR WiMAX INSTALLATIONS ONLY:** Use the scroll bar on the left side of the page to scroll down to view the next part of the windows shown in Figure 7-26.

Figure 7-26 AdminBrowser Configuration Window WiMAX ONLY

The screenshot shows the 'Band' configuration window for WiMAX. It includes sections for 'Protocol' (MIMO selected), 'Center Frequency (MHz)' (2511), 'Bandwidth (MHz)' (30), 'TDD Parameters' (Switching Mode: Static-Auto, Number of Symbols: 29,19), 'Band Synchronization Mode' (Unsynchronized), and 'Reference' (Band 2). At the bottom, there are controls for 'Band 1' and 'Band 2', including 'Shutdown' checkboxes, 'Uplink Gain (dB)', 'Downlink Gain (dB)', and 'Uplink Automatic Level Control' (Multiple).

In the Band area, do the following:

- Select the Protocol mode: This configures the system to support WiMAX radios that are one of the following:  
**MIMO** (multiple in-multiple out)  
**SISO** (single in-single out). The default is “MIMO”.

- Select the Center Frequency and Bandwidth using the arrows next to the fields. The center frequency is the frequency of WiMAX radios being used for Band 1 and Band 2.

---

**NOTE:** In MIMO mode, the frequencies are the same. The system can be configured to support 2-SISO radios, one per band, across any 30 MHz within the WiMAX band.

---

- Use the pull-down to select the Switching Mode. This indicates whether or not the downlink-to-uplink frame duration is known. The two options are as follows:
  - **Static-Selected:** This mode specifies the number of symbols. Use the pull-down to select the symbol in the downlink and uplink portions of the frame. (The default is “29,18”.) In this mode, the system always switches from the downlink to the uplink path after the downlink portion of the frame has elapsed.
  - **Static-Auto:** This mode causes the system to attempt to determine the correct switching time, then enforce it. (The default is “Static-Auto”)
- Select the Band Synchronization Mode with the pull-down. This parameter can be configured to operate as one of the following:
  - **Synchronized:** This mode is for cases like MIMO, where the timing for both bands is the same. In this mode, the system always switches between uplink and downlink simultaneously for both bands.
  - **Unsynchronized:** In this mode, the two WiMAX bands switch independently from each other. (The default is “Unsynchronized”)
- **Reference:** Select which WiMAX radio band will be used for frame reference.
- When any band is not configured, use the Shutdown check box. The system ignores any alarms generated from the shutdown bands.
- Use the pull-down to specify the Uplink and Downlink gain for each band. You can set system gain within the specified range in 1 dB increments.
- Use the pull-down to set the Uplink Automatic Level Control to either “Single” or “Multiple” for each band in the system. (The default is “Multiple.”)



12. Use the scroll bar on the left side of the window to scroll down to view the rest of the window as shown below.

The screenshot shows a configuration window with two sections: 'Input Alarms' and 'Output Alarms'. Below these is a warning message and an 'Install System' button.

Input Alarms			
	Enable	Normal State	Label
Alarm Sense 1	<input type="checkbox"/>	Closed	Pumpkin
Alarm Sense 2	<input type="checkbox"/>	Closed	Pie
Alarm Sense 3	<input checked="" type="checkbox"/>	Closed	Spices

Output Alarms		
	Enable	Normal State
Fault Source	<input checked="" type="checkbox"/>	Closed
Warning Source	<input checked="" type="checkbox"/>	Closed

Warning: This operation will erase the Time-Tagged Log and perform a system test.

Install System

13. In the Input/Output Alarms area, do the following for each Alarm Sense:
- Enable each Alarm Sense by using the check box.
  - Use the pull-down to set the Normal State to Closed or Opened. (The default is “Closed.”)
  - Assign a label to each alarm sense.
14. When you have completed inputting the desired information, click **Install System** to configure the system.

During configuration all disconnect statuses are cleared for attached RAUs; the frequency band, gain, and system label are set; logs are cleared; the system test is performed; and finally the system tree is refreshed. The icons should be:



Indicating that the band is correctly set on the Main Hub.



Indicating that the band is correctly set on the Expansion Hub.



Indicating that communications are OK.

If there are problems, the icons will be different and a message is displayed in the Messages pane.

15. Connect the Main Hub to the RF source (for example, BTS or BDA).

**Do not exceed the maximum input RF power (1 Watt) to the Fusion Wideband Main Hub. Exceeding the limit could cause permanent damage to the Hub.**

---

**CAUTION:** Only carriers and their approved installers or ADC-authorized installers are allowed to connect to the RF source. **Serious damage to the equipment can occur if it is over-driven.**

---

The Fusion Wideband system should now be operational. Using a mobile phone, walk your site and test the signal strength.

16. Make sure to change the TCP/IP setting in your laptop back to their original values.

---

**NOTE:** ADC equipment is designed to operate in the licensed frequency bands of mobile operators. In the USA, the EU, and most countries this equipment may only be used by the licensee, his authorized agents or those with written authorization to do so. Similarly, unauthorized use is illegal, and subjects the owner to the corresponding legal sanctions of the national jurisdiction involved. Ownership of ADC equipment carries no automatic right of use.

---

---

## 7.5 Splicing Fiber Optic Cable

The fiber cable must have SC/APC connectors for the entire run. If it does not, you can splice a pigtail, which has SC/APC connectors, to the fiber cable.

ADC offers two pigtails: one for single-mode fiber (PN 4013SCAPC-3) and one for multi-mode fiber (PN 4012SCAPC-3).

ADC recommends fusion splices because they have the lowest splice loss and return loss. Mechanical splices have higher losses and higher back reflection than fusion splices and are not recommended.

Using a fusion splicer involves fusing together two butted and cleaved ends of fiber. The fusion splicer aligns the fibers and maintains alignment during the fusion process. Fusion splices have very low loss (typically less than 0.05 dB) and very low back reflection (return loss). Fusion splices should be organized in a splice tray designed to store and protect the splices.

### Fusion Splicing of Fiber and Pigtail

Before you begin, make sure the fusion splicer is set to the proper mode (that is, single- or multi-mode).

#### **To fusion splice the fiber optic cable to the SC/APC pigtail: Option A**

1. Secure both the fiber cable and the SC/APC pigtail in a splice tray that is installed immediately adjacent to the Hub.
2. Prepare the fiber end by cutting back the polyethylene jacket, the kevlar or fiber-glass strength members, the extruded coating, and the buffer coating in order to expose the “bare fiber” – cladding plus core.

Ensure that sufficient slack is maintained in order to be able to reach the fusion splicer.

3. Clean the unclad fiber core using isopropyl alcohol and lint-free wipes.
4. Cleave the unclad fiber to the length prescribed by the fusion splicer’s specification sheets.

5. Repeat steps 2 through 4 for the SC/APC pigtail.
6. Pass the splice sleeve onto the fiber strand.
7. Position both fiber ends in the fusion splicer and complete splice in accordance with the fusion splicer's operation instructions.
8. Ensure that the estimated loss for the splice as measured by the fusion splicer is 0.10 dB or better.
9. Slide the fusion splicing sleeve over the point of the fusion splice.
10. Place the sleeve and fused fiber into the fusion splicer's heater.
11. Allow time for the splice sleeve to cure.
12. Return fiber splice to the splice tray, store the sleeve in a splice holder within the tray, and store excess cable length in accordance with the tray manufacture's directions.

After successfully testing the fiber, plug the SC/APC pigtail into the proper optical port on the Hub.

**To fusion splice the fiber optic cable to the SC/APC pigtail: Option B**

1. Secure both the fiber cable and the SC/APC pigtail in a splice tray portion of a fiber distribution panel.
2. Prepare the fiber end by cutting back the polyethylene jacket, the kevlar or fiber-glass strength members, the extruded coating, and the buffer coating in order to expose the "bare fiber" – cladding plus core.  
Ensure that sufficient slack is maintained in order to be able to reach the fusion splicer.
3. Clean the unclad fiber core using isopropyl alcohol and lint-free wipes.
4. Cleave the unclad fiber to the length prescribed by the fusion splicer's specification sheets.
5. Repeat steps 2 through 4 for the SC/APC pigtail.
6. Pass the splice sleeve onto the fiber strand.
7. Position both fiber ends in the fusion splicer and complete splice in accordance with the fusion splicer's operation instructions.
8. Ensure that the estimated loss for the splice as measured by the fusion splicer is 0.10 dB or better.
9. Slide the fusion splicing sleeve over the point of the fusion splice.
10. Place the sleeve and fused fiber into the fusion splicer's heater.
11. Allow time for the splice sleeve to cure.
12. Return fiber splice to the splice tray, store the sleeve in a splice holder within the tray, and store excess cable length in accordance with the tray manufacture's directions.
13. After successfully testing the fiber cable, plug the SC/APC pigtail into the back side of the SC/APC bulkhead in the Fiber Distribution Panel.

Install a SC/APC patch cord between the front side of the SC/APC bulkhead and the proper optical port on the Hub.

---

**NOTE:** Refer to Section 9 for troubleshooting.

---

---

## 7.6 Interfacing the Fusion Wideband Main Hub to an RF Source



**WARNING:** Only ADC personnel or ADC-authorized installation personnel should connect the Fusion Wideband Main Hub to its Band associated base station or repeater. Exceeding the maximum input power could cause failure of the Fusion Wideband Main Hub (refer to Section 5.2 on page 5-4 for maximum power specifications). If the maximum composite power is too high, attenuation is required.

---

### 7.6.1 Connecting a Single Fusion Wideband Main Hub to an RF Source

The Fusion Wideband system supports up to three RF sources, one for Band 1, one for Band 2, and one for Band 3. This section explains how each Band can be connected to its associated RF source.



### Connecting a Fusion Wideband Main Hub to an In-Building BTS



**WARNING:** Only ADC personnel or ADC-authorized installation personnel should connect the Fusion Wideband Main Hub to a base station or repeater. Exceeding the maximum input power could cause failure of the Fusion Wideband Main Hub (refer to Section 5.2 on page 5-4 for maximum power specifications). If the maximum composite power is too high, attenuation is required.

---

**CAUTION:** The **UPLINK** and **DOWNLINK** ports cannot handle a DC power feed from the base station. If DC power is present, a DC block must be used or the hub may be damaged.

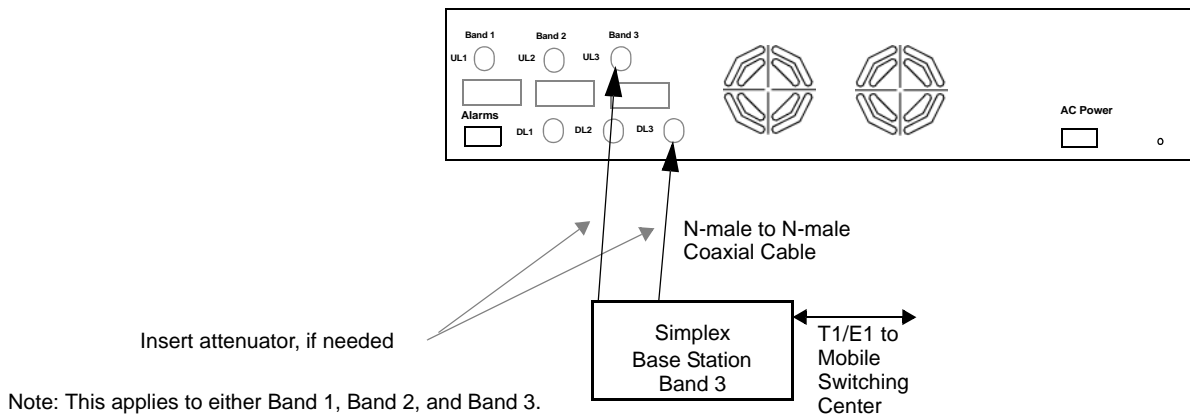
---

#### Connecting a Simplex Base Station to a Fusion Wideband Main Hub RF Band:

1. Connect an N-male to N-male coaxial cable to the transmit simplex connector on the base station.

2. Connect the other end of the N-male to N-male coaxial cable to the **DOWNLINK** connector on the Hub for the corresponding Band 1 or Band 2.
3. Connect an N-male to N-male coaxial cable to the receive simplex connector on the base station.
4. Connect the other end of the N-male to N-male coaxial cable to the **UPLINK** connector on the Hub for the corresponding Band 1 or Band 2.

**Figure 7-27 Simplex Base Station to a Fusion Wideband Main Hub**



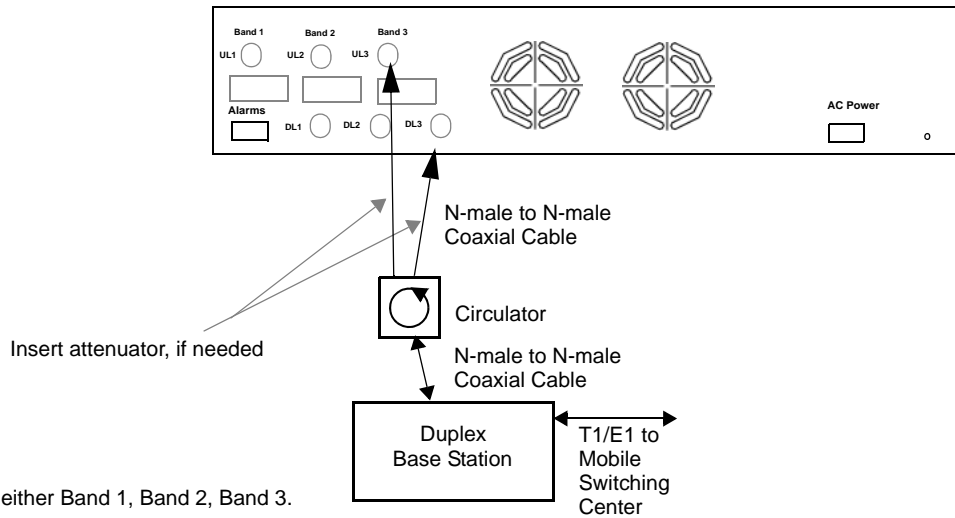
**Connecting a Duplex Base Station to a Fusion Wideband Main Hub:**

When connecting to a duplex base station, use a circulator or duplexer between it and the Fusion Wideband Main Hub.

You can insert attenuators between the circulator or duplexer and Hub as needed.

1. Connect an N-male to N-male coaxial cable to the duplex connector on the base station.
2. Connect the other N-male connector or duplexer to a circulator.
3. Connect an N-male to N-male coaxial cable to the **DOWNLINK** connector on the Hub for Band 1, Band 2, and Band 3.
4. Connect the other end of the N-male coaxial cable to the transmit connector on the circulator.
5. Connect an N-male to N-male coaxial cable to the **UPLINK** connector on the Hub for Band 1, and Band 2, and Band 3.
6. Connect the other end of the N-male coaxial cable to the receive connector on the circulator.

Figure 7-28 Duplex Base Station to a Fusion Wideband Main Hub



**Note:** This applies to either Band 1, Band 2, Band 3.

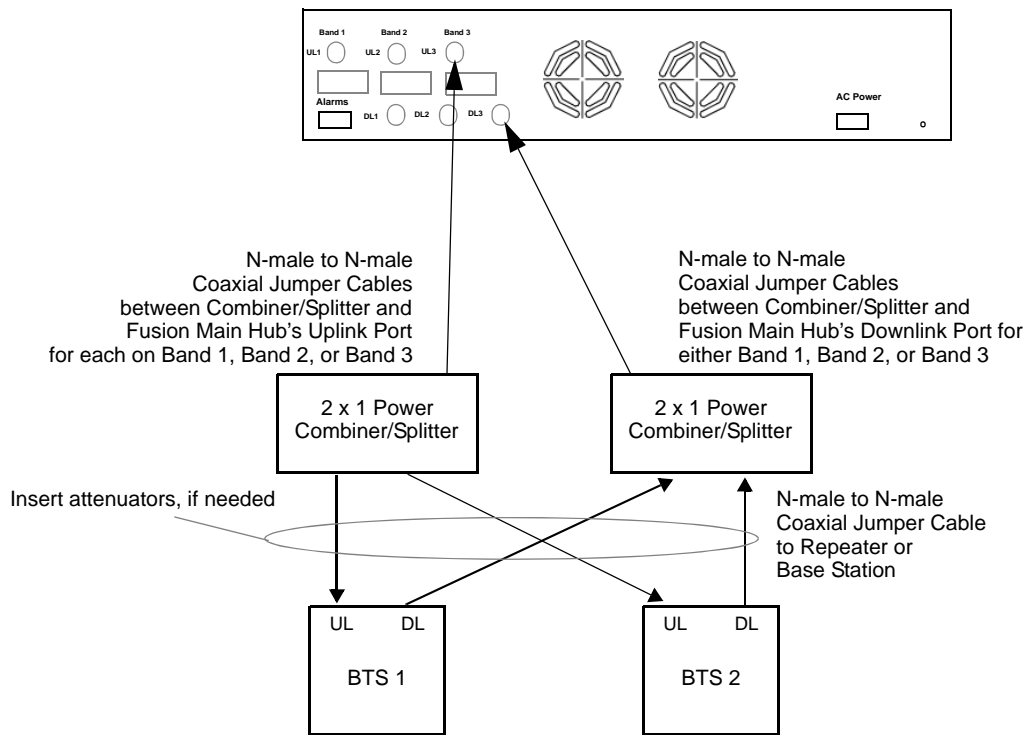
✓ **Connecting a Fusion Wideband Main Hub RF Band to Multiple BTSs**



**WARNING:** Only ADC personnel or ADC-authorized installation personnel should connect the Fusion Wideband Main Hub to a base station or repeater. Exceeding the maximum input power could cause failure of the Fusion Wideband Main Hub (refer to Section 5.2 on page 5-4 for maximum power specifications). If the maximum composite power is too high, attenuation is required.

You can use power combiner/splitters to connect a Fusion Wideband Main Hub RF Band to multiple base stations, as shown in Figure 7-29.

**Figure 7-29 Connecting a Fusion Wideband Main Hub to Multiple Base Stations**



### ✓ Connecting a Fusion Wideband Main Hub to a Roof-top Antenna

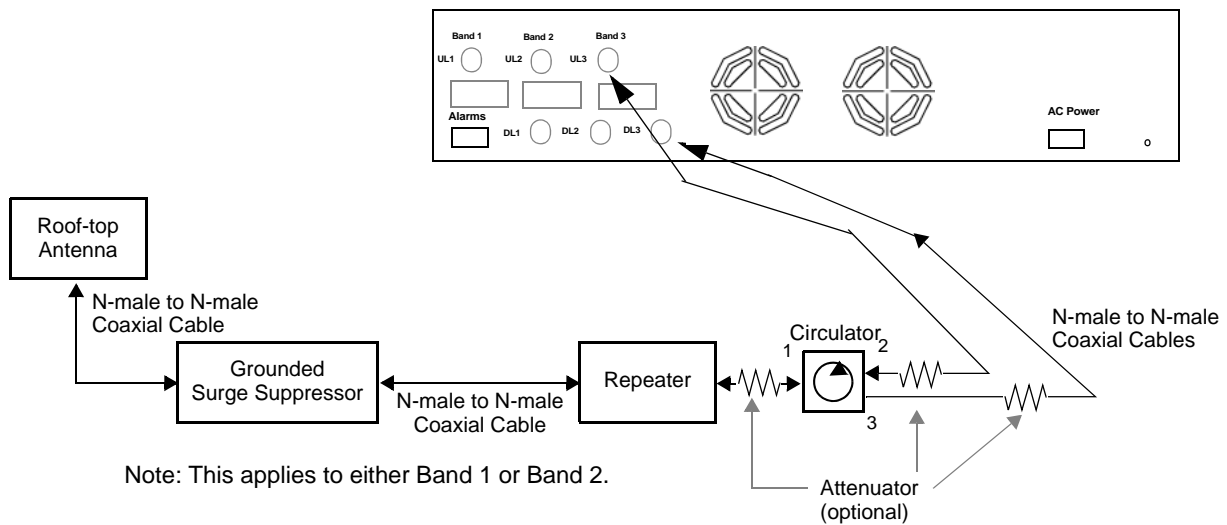
ADC recommends that you use a lightning arrestor or surge protector in a roof-top antenna configuration. Insert the lightning arrestor or surge protector between the roof-top antenna and the repeater connected to the Fusion Wideband Main Hub RF Band.

1. Connect an N-male to N-male coaxial cable to the roof-top antenna.
2. Connect the other end of the N-male to N-male coaxial cable to the grounded surge suppressor.
3. Connect an N-male to N-male coaxial cable to the grounded surge suppressor.
4. Connect the other end of the N-male to N-male coaxial cable to the repeater.
5. Connect an N-male to N-male coaxial cable to the repeater.
6. Connect the other end of the N-male to N-male coaxial cable to the circulator 1 connector.
7. Connect an N-male to N-male coaxial cable to the circulator 2 connector.
8. Connect the other end of the N-male to N-male coaxial cable to the **DOWNLINK** connector on the Hub for either Band 1 or Band 2.

Attenuation may be required to achieve the desired RF output at the RAU.

9. Connect an N-male to N-male coaxial cable to the circulator 3 connector.
10. Connect the other end of the N-male to N-male coaxial cable to the **UPLINK** connector on the Hub for either Band 1 or Band 2.

**Figure 7-30 Connecting a Fusion Wideband Main Hub to a Roof-top Antenna**





✓ **Connecting a Fusion Wideband Main Hub to FlexWave Focus**

Refer to the FlexWave Focus manual for information.

**7.6.2 Connecting Multiple Fusion Wideband Main Hubs to an RF Source**

You can use power combiner/splitters as splitters to connect multiple Fusion Wideband Main Hubs in order to increase the total number of RAUs in a system. You can also use power combiner/splitters to combine base station channels in order to increase the number of RF carriers the system transports.

✓ **Connecting Multiple Fusion Wideband Main Hubs to a Simplex Repeater or BTS**



---

**WARNING:** Only ADC personnel or ADC-authorized installation personnel should connect the Fusion Wideband Main Hub to a base station or repeater. Exceeding the maximum input power could cause failure of the Fusion Wideband Main Hub (refer to Section 5.2 on page 5-4 for maximum power specifications). If the maximum composite power is too high, attenuation is required.

---

**Considerations:**

- 2 hybrid power combiner/splitters; one for uplink and one for downlink (2x1 for two Fusion Wideband Main Hubs, 3x1 for three, 4x1 for four, and so on.)
- 1 N-male to N-male coaxial jumper cable between each power combiner/splitter and the base station
- 2 N-male to N-male coaxial jumper cables between each power combiner/splitter and each Fusion Wideband Main Hub RF Band (either Band 1, Band 2, or Band 3)

**Procedure:**

1. Connect the power combiner/splitters to the repeater or base station using N-male to N-male coaxial jumper cables:
  - a. From the first power combiner/splitter to the repeater or base station **UPLINK**
  - b. From the second power combiner/splitter to the repeater or base station **DOWNLINK**
2. Connect the power combiner/splitters to the Hubs:
  - a. From the first Hub's **UPLINK** port (Band 1, Band 2, or Band 3) to the first power combiner/splitter
  - b. From the first Hub's **DOWNLINK** port (Band 1, Band 2, or Band 3) to the second power combiner/splitter
  - c. From the second Hub's **UPLINK** port (Band 1, Band 2, or Band 3) to the first power combiner/splitter

- d. From the second Hub's **DOWNLINK** port (Band 1, Band 2, or Band 3) to the second power combiner/splitter

---

**NOTE:** Connections should not cross Bands. For example, all Band 1 connections should be made to the same hybrid power combiner/splitter connected to the repeater BTS that matches the Band 1 frequency.

---

3. Check Hub LEDs.

After connecting and powering on the Hub, check all LEDs to ensure that the system is operating properly.

**Make sure the Hub is grounded. The warranty does not cover damage caused when an ungrounded Hub is powered on.**

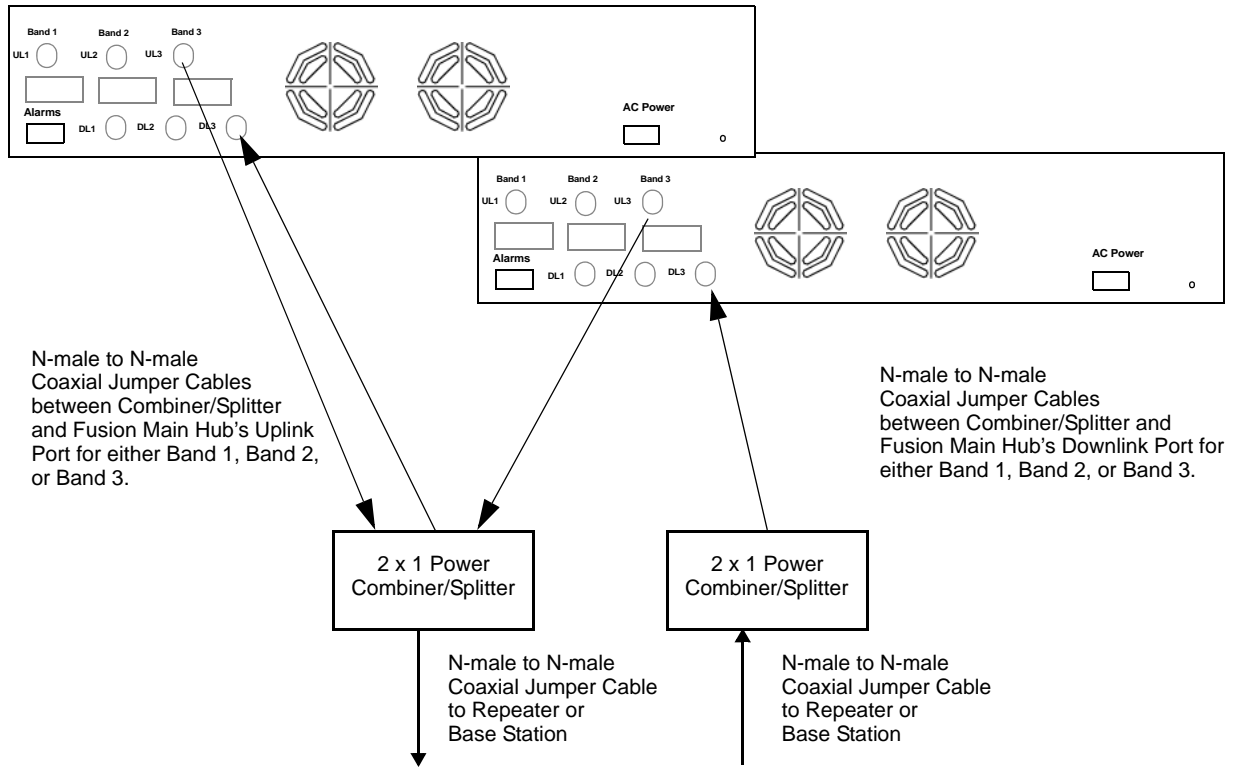
---

**NOTE:** Use a 50 ohm terminator on any unused power combiner/splitter ports.

---

Figure 7-31 shows how to connect two Main Hubs to a simplex repeater or base station. Connecting two Hubs increases the total number of supportable RAUs from 8 to 16.

**Figure 7-31 Connecting Two Fusion Wideband Main Hub's RF Band Ports to a Simplex Repeater or Base Station**



✓ **Connecting Multiple Wideband Main Hubs to a Duplex Repeater or BTS**



**WARNING:** Only ADC personnel or ADC-authorized installation personnel should connect the Fusion Wideband Main Hub to a base station or repeater. Exceeding the maximum input power could cause failure of the Fusion Wideband Main Hub (refer to Section 5.2 on page 5-4 for maximum power specifications). If the maximum composite power is too high, attenuation is required.

**Considerations:**

- 2 hybrid power combiner/splitters; one for uplink and one for downlink (2x1 for two Fusion Wideband Main Hubs, 3x1 for three, 4x1 for four, and so.)
- 2 N-male to N-male coaxial jumper cables to connect each Fusion Wideband Main Hub's RF Band to the power combiner/splitters
- 1 circulator
- 1 N-male to N-male coaxial jumper cable between each circulator and the repeater or base station
- 1 N-male to N-male coaxial jumper cable between each circulator and power combiner/splitter

**Procedure:**

1. Connect the circulator to the repeater or base station using one N-male to N-male coaxial jumper cable.
2. Connect each power combiner/splitter to the circulator using one N-male to N-male coaxial jumper cable per combiner/splitter.
3. Connect the power combiner/splitter to the Hubs using N-male to N-male coaxial jumper cable:
  - a. From the first Hub's **UPLINK** (Band 1, Band 2, or Band 3) port to the first power combiner/splitter
  - b. From the first Hub's **DOWNLINK** (Band 1, Band 2, or Band 3) port to the second power combiner/splitter
  - c. From the second Hub's **UPLINK** (Band 1, Band 2, or Band 3) port to the first power combiner/splitter
  - d. From the second Hub's **DOWNLINK** (Band 1, Band 2, or Band 3) port to the second power combiner/splitter

**NOTE:** Connections should not cross Bands. For example, all Band 1 connections should be made to the same hybrid power combiner/splitter connected to the repeater BTS that matches the Band 1 frequency.

4. Check Hub LEDs.

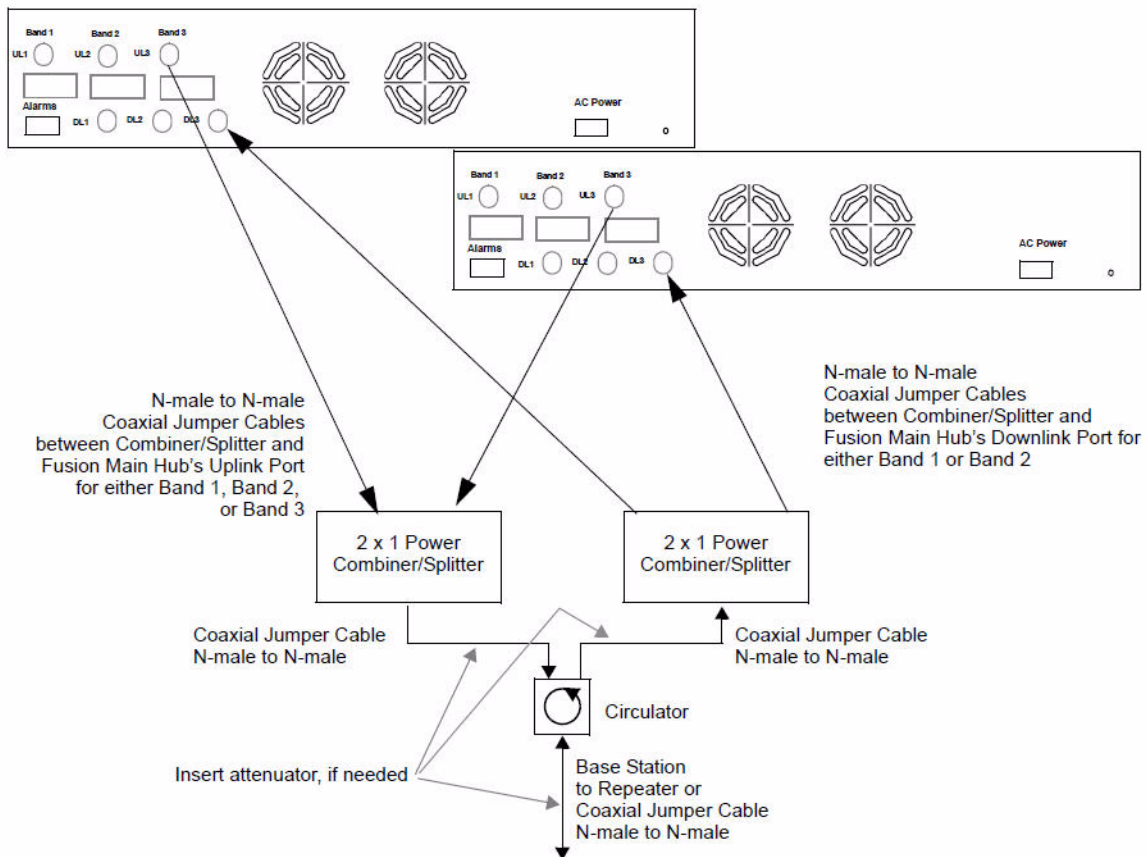
After connecting and powering on the Hub, check all LEDs to ensure that the system is operating properly.

**Make sure the Main Hub is grounded. The warranty does not cover damage caused when an ungrounded Hub is powered on.**

**NOTE:** Use a 50 ohm terminator on any unused power combiner/splitter ports.

Figure 7-32 shows how to connect two Hubs to a duplex repeater or base station. You need to use one circulator and one more coaxial jumper cable, as shown.

**Figure 7-32 Connecting Two Fusion Wideband Main Hub's RF Band Ports to a Duplex Repeater or Base Station**



## 7.7 Connecting Contact Alarms to a Fusion Wideband System

The Fusion Wideband Main Hub can generate (source) two contact alarms as well as sense three external contact alarm.

- **Alarm Source (refer to Section 7.7.1 on page 7-57)**

The Fusion Wideband Main Hub has two alarm contacts, fault (major) and warning (minor). These contacts are normally-closed (NC) and will open when an internal alarm is detected.

**NOTE:** The contact can be changed to normally-open (NO) with Admin-Browser. This is not recommended since no alarm would be sent if power to the Fusion Wideband Main Hub fails.

- Fault is activated when any faults or disconnects are detected.
- Warning is activated when any warning conditions are detected except lockout or when the end-to-end system test is not valid.
- **Alarm Sense (refer to Section 7.7.2 on page 7-60)**

The Fusion Wideband Main Hub can monitor 3 external alarm contacts. Each port can be configured for normally-open (NO) or normally-closed (NC) contacts. The interface expects a set of floating contacts, and an external voltage source is not required for this interface. Use AdminBrowser to monitor the port status.

Table 7-8 lists the alarm types, equipment to which the Fusion Wideband Main Hub is connected, cable(s) used, and the faults and warnings that are detected.

**Table 7-8 Alarm Types**

Alarm Type	Fusion Wideband Connected to	Cable(s) Used	Errors Detected
Source	FlexWave	5-port Alarm Daisy-Chain Cable	Faults
Source	BTS	5-port Alarm Daisy-Chain Cable	Faults and Warnings
		In addition, a custom daisy-chain cable-to-BTS interface cable is required. Make this interface cable to the desired length and with the appropriate pin placement.	
Sense	Unison	5-port Alarm Daisy-Chain Cable and the Alarm Sense Adapter Cable	Faults

Note that FlexWave Focus supports only faults (major errors).

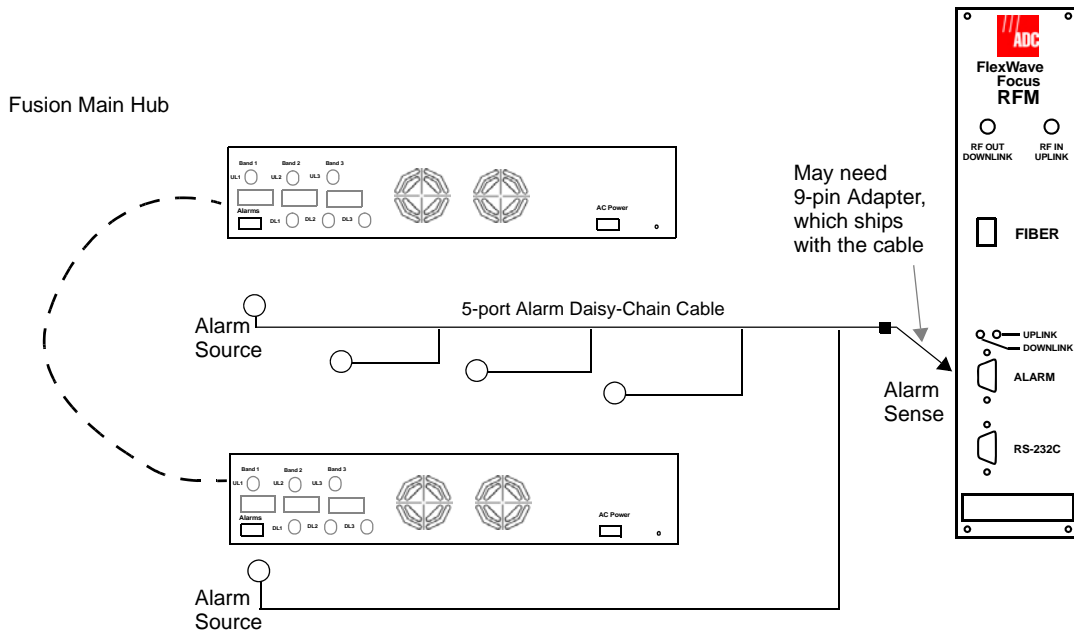
### 7.7.1 Alarm Source

Fusion Wideband always acts as an alarm source, no matter what type of equipment you are connecting to. Refer to Section 7.7.2 on page 7-60 if you want Fusion Wideband to sense Unison contact closures or other external alarms.

#### Using FlexWave Focus to Monitor Fusion Wideband

When you connect FlexWave Focus to the Fusion Wideband, the Fusion Wideband Main Hub is the output of the alarms (alarm source) and Focus is the input (alarm sense), as shown in Figure 7-33. Focus supports only faults (major errors).

**Figure 7-33 Connecting FlexWave to Fusion Wideband**



### Using a Base Station to Monitor Fusion Wideband

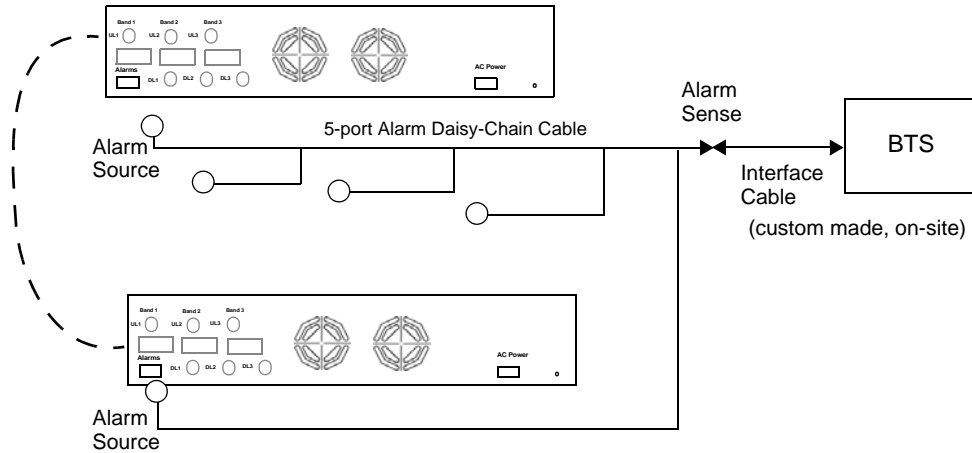
**NOTE:** The BTS must be configured, by the carrier, for contact closure monitoring prior to connecting a Fusion Wideband Main Hub to it.

---

When you connect a BTS to Fusion Wideband, the Fusion Wideband Main Hub is the output of the alarms (alarm source) and the BTS is the input (alarm sense), as shown in Figure 7-34. An interface cable is required between the daisy-chain cable and the BTS. Because BTS alarm interface pinouts and Fusion Wideband-to-BTS distances vary, this cable is often custom and wired on-site. Refer to Section 3.2.1 for Alarm Contact details (Normally Closed).

**Figure 7-34** Using a BTS to Monitor Fusion Wideband

---



**NOTE:** For normally open contacts, the fault and warning contacts need to be wired in parallel with other Main Hubs.

---

**NOTE:** ADC does not recommend using normally open contacts.

---

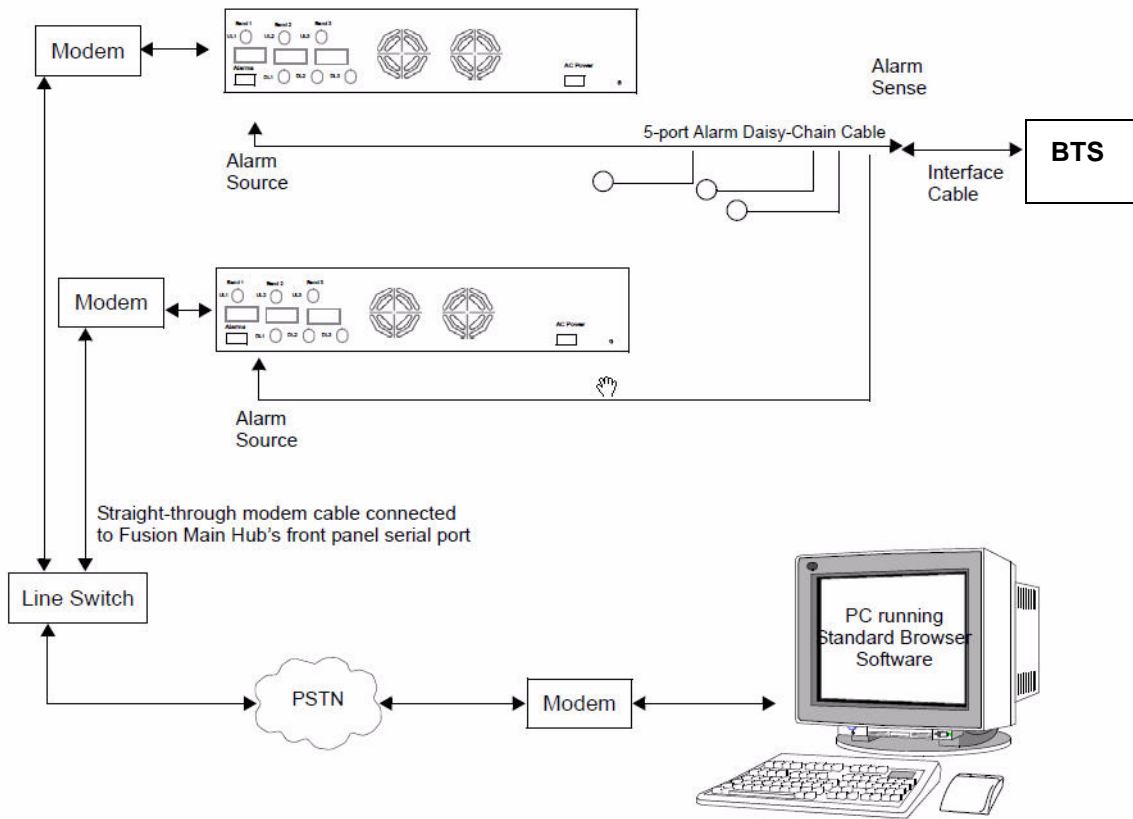


### Using a Base Station and AdminBrowser to Monitor Fusion Wideband

**NOTE:** The BTS must be configured, by the carrier, for contact closure monitoring prior to connecting a Fusion Wideband Main Hub to it.

In order to take full advantage of Fusion Wideband’s OA&M capabilities you can use ADC’s AdminBrowser software in addition to a BTS to monitor the system, as shown in Figure 7-35. Refer to Section 7.8.7 for SNMP optional feature capabilities.

**Figure 7-35 Using a BTS and AdminBrowser to Monitor Fusion Wideband**



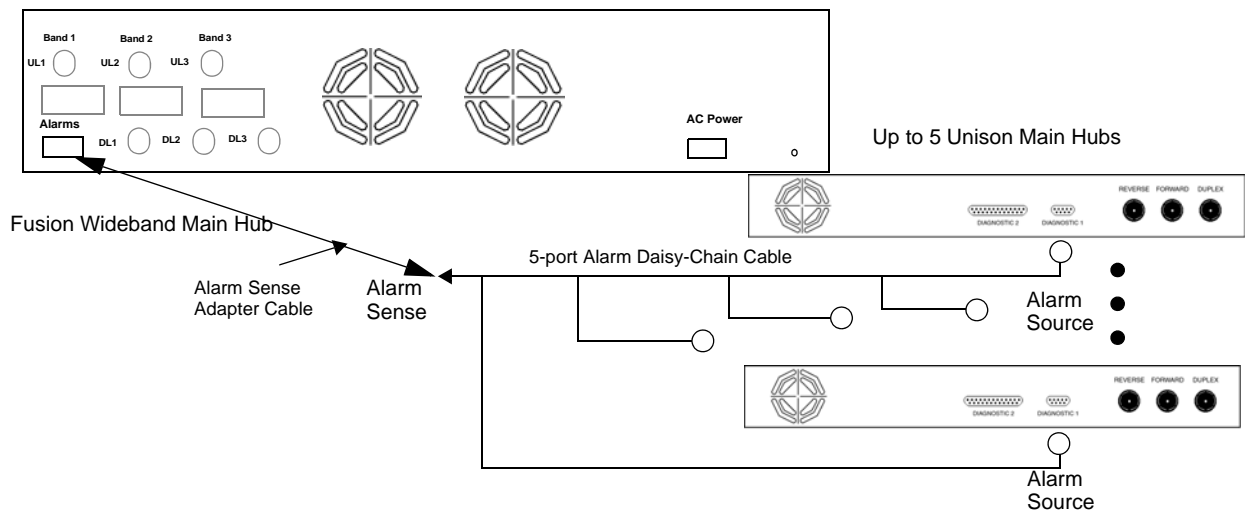
### 7.7.2 Alarm Sense

Use AdminBrowser to enable the Fusion Wideband system for “alarm sense” when connecting to the contact closure of Unison Main Hubs or other external alarms (refer to Set Contact Sense Properties in the *AdminBrowser User Manual*).

#### Using Fusion Wideband to Monitor Unison

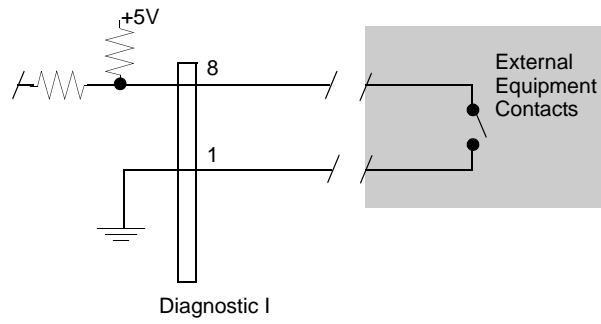
When you connect Unison to Fusion Wideband, the Fusion Wideband Main Hub is the input of the alarms (alarm sense) and the Unison is the output (alarm source), as shown in Figure 7-36. The input alarm sense needs to be set to normally closed (NC).

Figure 7-36 Using Fusion Wideband to Monitor Unison



Unison supports only faults. You must use the Alarm Sense Adapter Cable to interface the daisy-chain cable to Fusion Wideband. The adapter cable is required because it translates the Unison fault pinout to the sense input pins on the Fusion Wideband Main Hub.

Figure 7-37 Alarm Sense Contacts

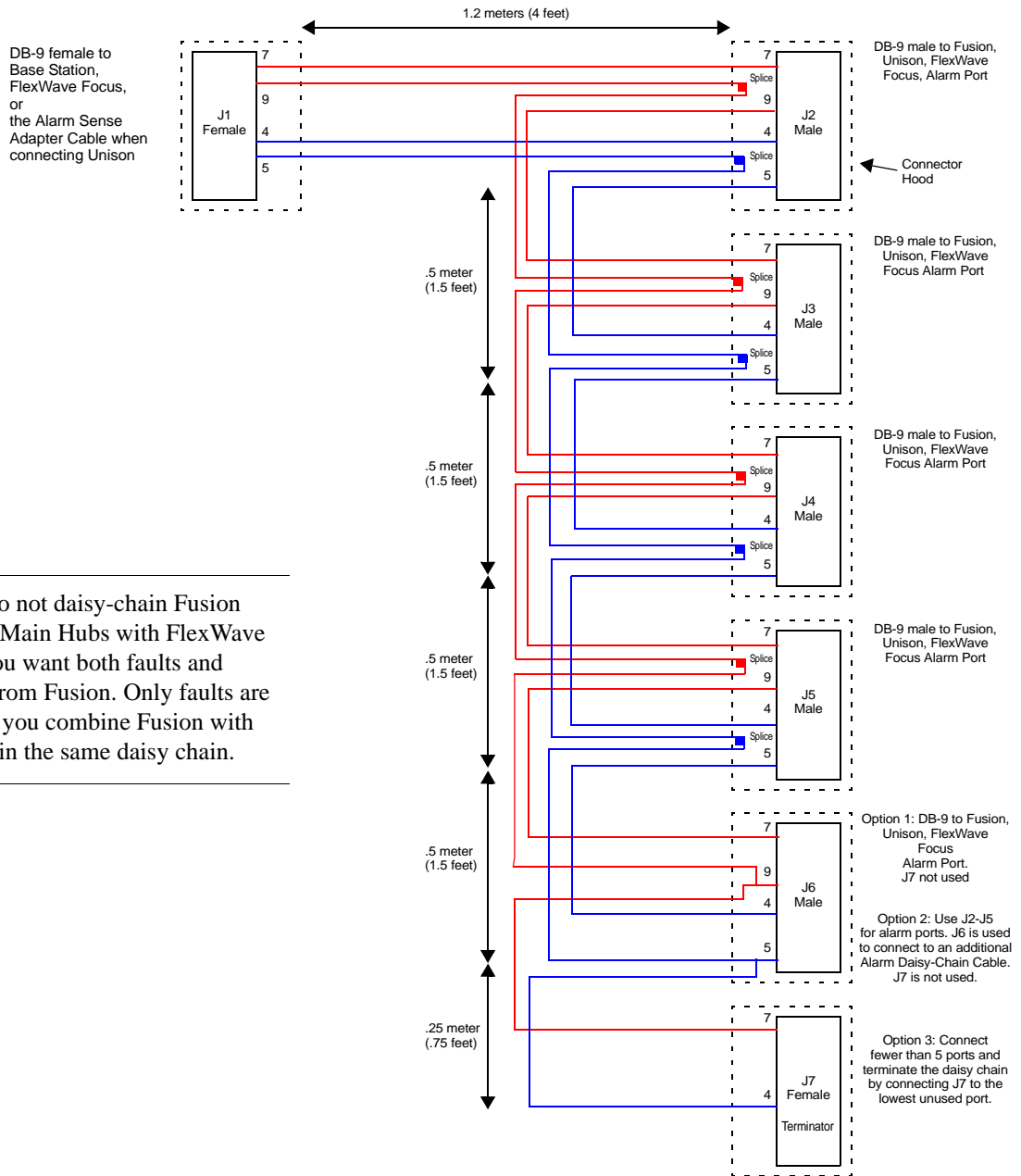


### 7.7.3 Alarm Cables

#### 5-port Alarm Daisy-Chain Cable

Figure 7-38 shows the 5-port Alarm Daisy-Chain Cable (PN 4024-3), which supports fault and warning conditions.

Figure 7-38 5-port Alarm Daisy-Chain Cable



## 7.8 Alarm Monitoring Connectivity Options

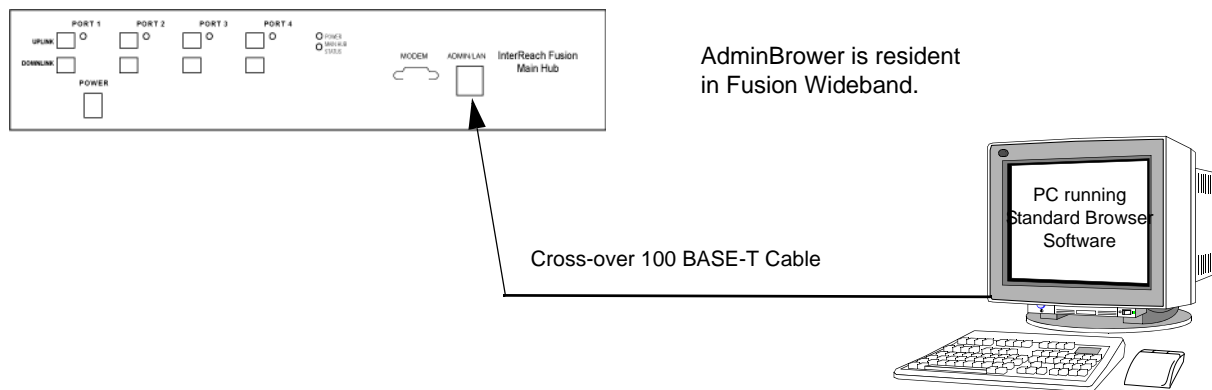
The following connectivity options are described:

- Section 7.8.1 Direct Connection . . . . . 7-63
- Section 7.8.2 Modem Connection . . . . . 7-64
- Section 7.8.3 100 BASE-T Port Expander Connection . . . . . 7-73
- Section 7.8.4 POTS Line Sharing Switch Connection . . . . . 7-74
- Section 7.8.6 Ethernet LAN Connection . . . . . 7-76
- Section 7.8.7 SNMP Interface . . . . . 7-77

### 7.8.1 Direct Connection

In this configuration, the PC connects directly to the **RJ-45 100 BASE-T** port on the Fusion Wideband Main Hub's front panel using an Ethernet cross-over cable.

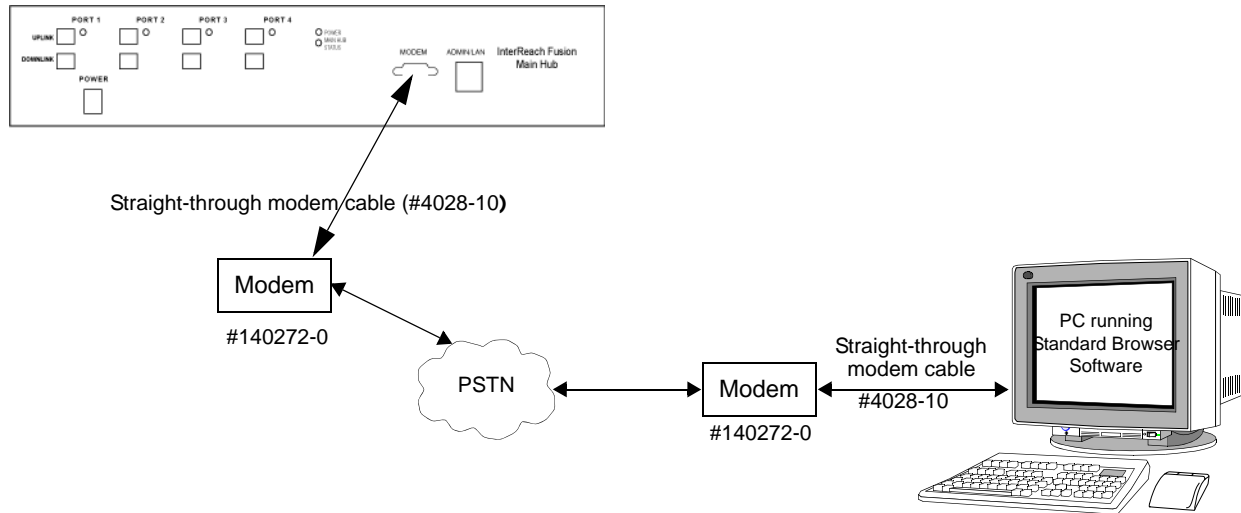
**Figure 7-39 OA&M Direct Connection**



## 7.8.2 Modem Connection

In this configuration, the PC and the Fusion Wideband Main Hub connect to analog modems and communicate using a standard dial-up telephone connection.

Figure 7-40 OA&M Modem Connection



**NOTE:** Refer to Appendix A.3 on page A-7 for the modem cable wiring information.

Modem switch settings are as follows for US Robotics modem:

- PC-side: 1, 2 and 6 Up
- Fusion Wideband Hub-side: 2 and 6 Up

### 7.8.2.1 Setting Up Fusion Wideband Modem (USR Modem) Using AdminBrowser

Use the following steps to set up a PPP Dial-In on Fusion Wideband:

1. Start AdminBrowser as explained in the AdminBrowser manual.
2. Select **System Configuration**.
3. Select **Setup Modem Connection**. The window shown in Figure 7-41 appears.

Figure 7-41 Default Dial-in Settings (Fusion Wideband Hub)

Welcome **operator.**  
(Read-Write User)

HOME LOGOUT

- System Configuration
  - Show System Tree
  - Edit Unit Properties
  - Set In Service
  - Set Out of Service
  - Perform System Test
  - Set Date/Time
  - Install System
  - Setup Network Connection
  - Setup Modem Connection
  - Setup SNMP
  - Activate Optional Features
  - Reset Settings to Factory Default
  - Reboot System
- System Information
- Alarms
- Users
- Updates
- Diagnostics
- Special Features

## System Configuration: Setup (Serial) Modem Connection

**Modem Initialization String**

**Dial-In**

**Server Address**

**Client Address**

**User Name**

**Password**

**Dial-Out**

Do not enable if you are using a wireless Ethernet modem.

**Enable**

**Phone Number**

**User Name**

**Password**

© 2008 ADC

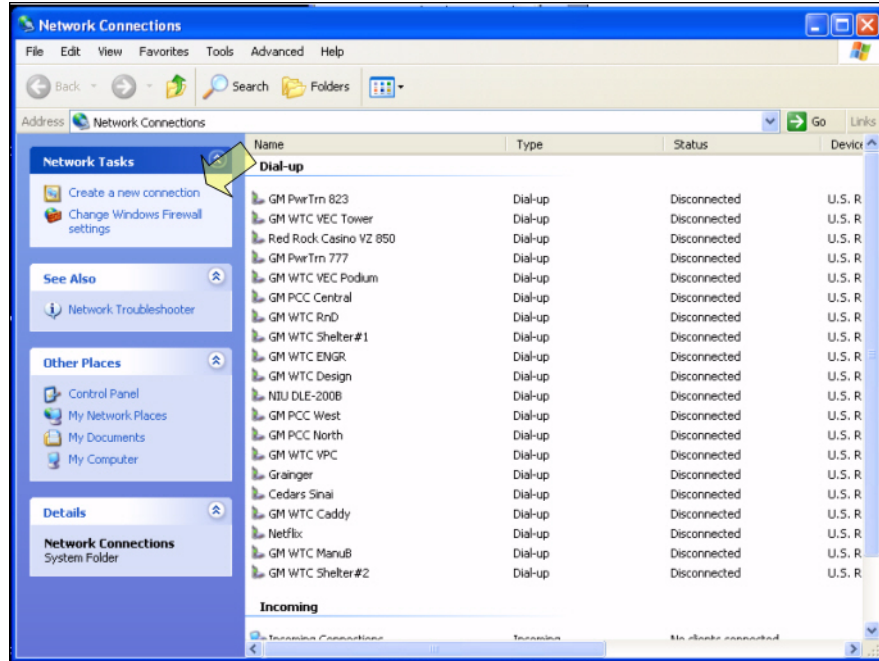
- Make sure the modem type is: “None”
  - The Modem init string is for a USB modem.
  - The server address is the IP address of the MH.
- Click **Setup Connection**.

### 7.8.2.2 Setting Up a PC Modem Using Windows

Use the following sets to set up a dial-up connection on your PC:

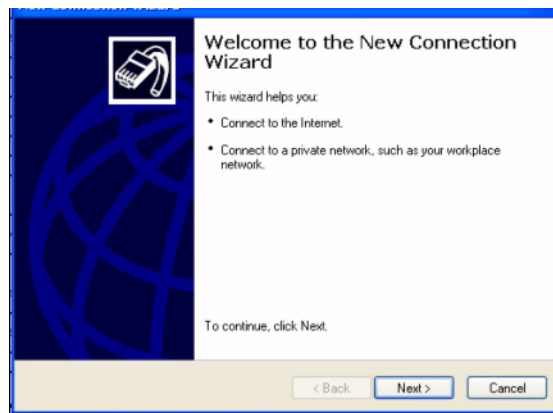
- Click **Start, Settings, Network Connections**. The window shown in Figure 7-42 appears.

Figure 7-42 Network Connections Window



2. Click **Create a new connection**. The window shown in Figure 7-43 appears.

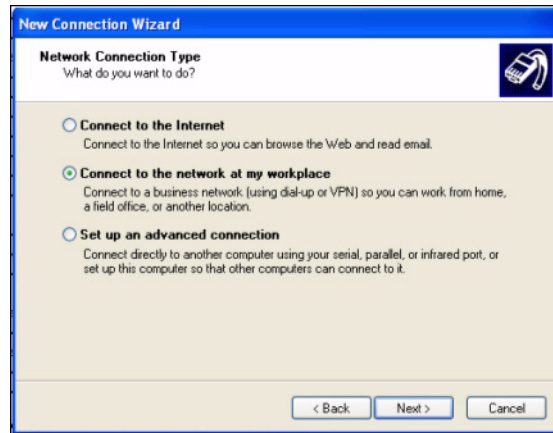
Figure 7-43 New Connection Wizard - Welcome Window



3. Click **Next**. The window shown in Figure 7-44 appears.

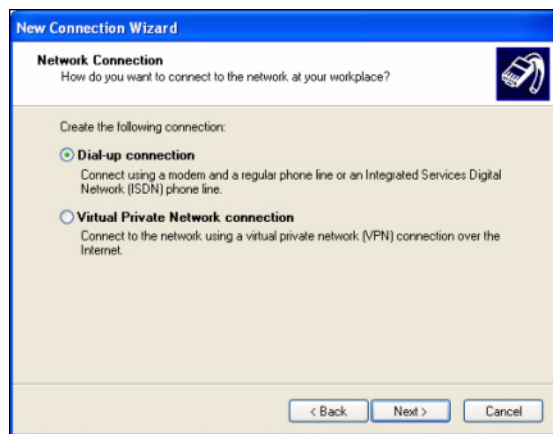


Figure 7-44 New Connection Wizard - Network Connection Type Window



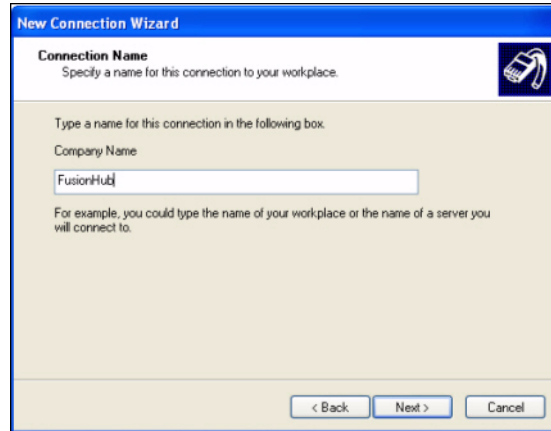
4. Select **Connect to the network at my workplace** and click **Next**. The window shown in Figure 7-45 appears.

Figure 7-45 New Connection Wizard - Network Connection Window



5. Select **Dial-up connection** and click **Next**. The window shown in Figure 7-46 appears.

**Figure 7-46 New Connection Wizard - Connection Name Window**



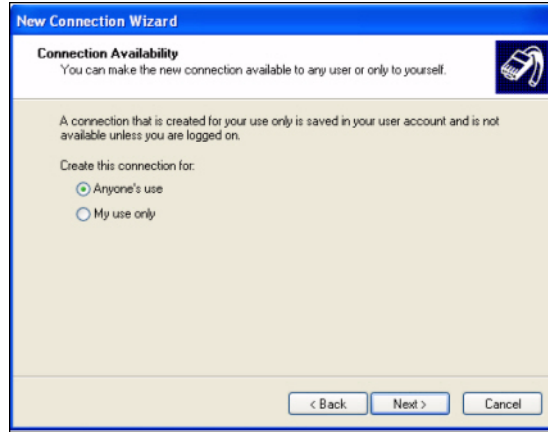
6. Type a name for this connection and click **Next**. The window shown in Figure 7-47 appears.

**Figure 7-47 New Connection Wizard - Phone Number to Dial Window**



7. Type the desired dial in phone number and click **Next**. The window shown in Figure 7-48 appears.

Figure 7-48 New Connection Wizard - Connection Availability Window



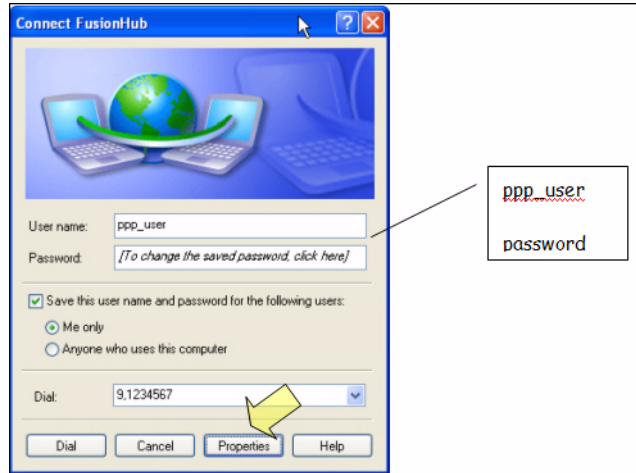
8. Select **Anyone's use** and click **Next**. The window shown in Figure 7-49 appears.

Figure 7-49 New Connection Wizard - Completing New Connection Window



9. Click **Finish**. The window shown in Figure 7-50 appears.

Figure 7-50 Connect Fusion Wideband Hub Window

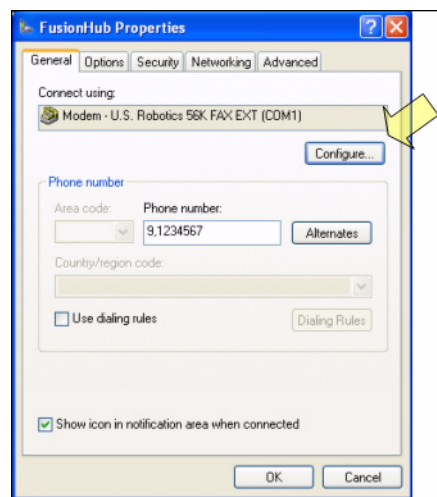


10. Type a password as indicated and click **Properties**. The window shown in Figure 7-51 appears.

The default parameters are as follows:

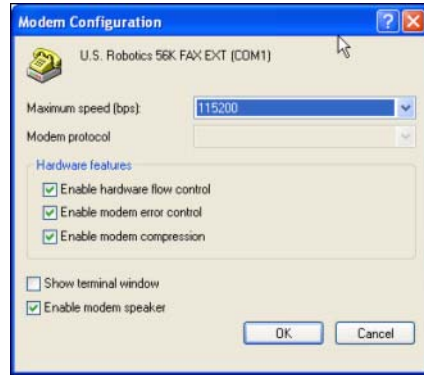
- User name: **ppp\_user**
- Password (one word, all lower case): **password**

Figure 7-51 Fusion Wideband Hub Properties Window



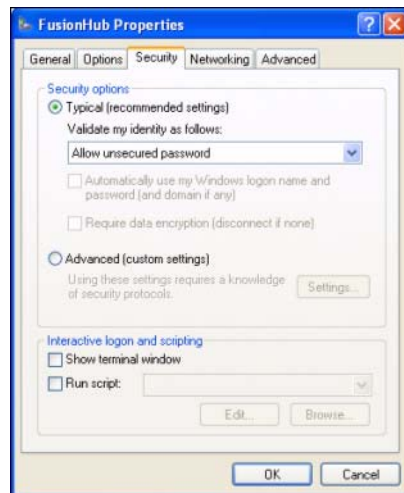
11. Click **Configure...** The window shown in Figure 7-52 appears.

Figure 7-52 Modem Configuration Window



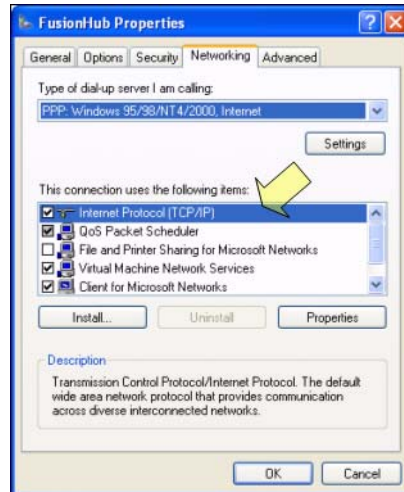
12. Select the modem speed and other parameters for your modem as desired and click **OK**.
13. Select the **Security** tab. The window shown in Figure 7-53 appears.

Figure 7-53 Fusion Wideband Hub Properties - Security Tab Window



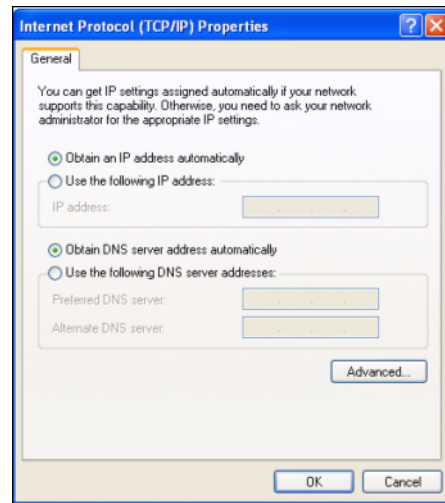
14. Select **Typical** and then click the **Networking** tab. The window shown in Figure 7-54 appears.

Figure 7-54 Fusion Wideband Hub Properties - Networking Tab Window



15. Select **Internet Protocol (TCP/IP)** as shown and click **Properties**. The window shown in Figure 7-55 appears.

Figure 7-55 Internet Protocol Properties Window

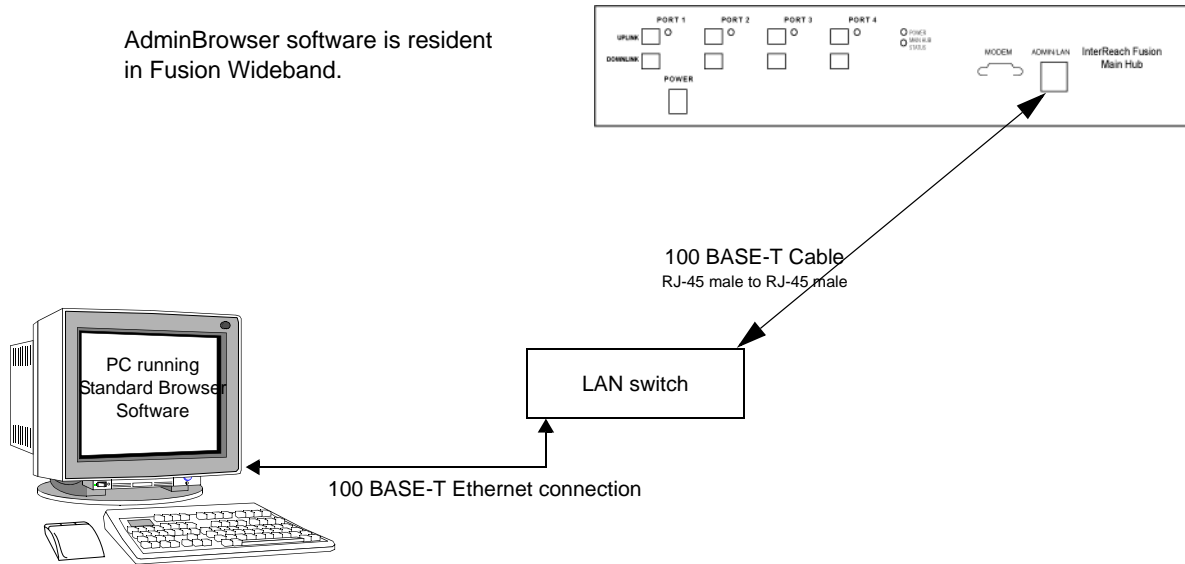


16. Select **Obtain an IP address automatically** and **Obtain DNS server address automatically** and click **OK**.
17. To connect to the Fusion Wideband Hub over the Dial-up connection, start your web browser and type the server IP address configured in Section 7.8.2.1 in the address bar.

### 7.8.3 100 BASE-T Port Expander Connection

In this configuration a LAN switch is used to allow the connection of multiple devices to a single PC with a 100 BASE-T port. Testing was performed with a Link-sys 4-port switch. Each Fusion Wideband MH must have a unique IP address.

Figure 7-56 OA&M Connection using a 232 Port Expander



### 7.8.4 POTS Line Sharing Switch Connection

Using a line sharing switch, you can connect two or more modems to a single telephone line.

Figure 7-57 OA&M Connection Using a POTS Line Sharing Switch

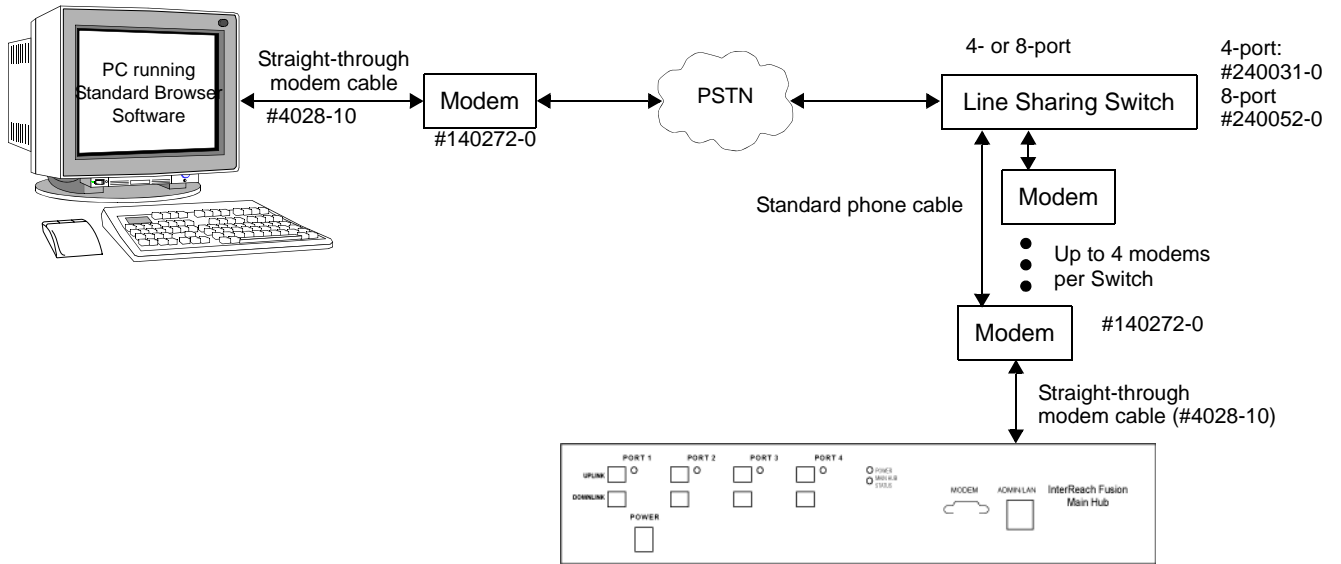
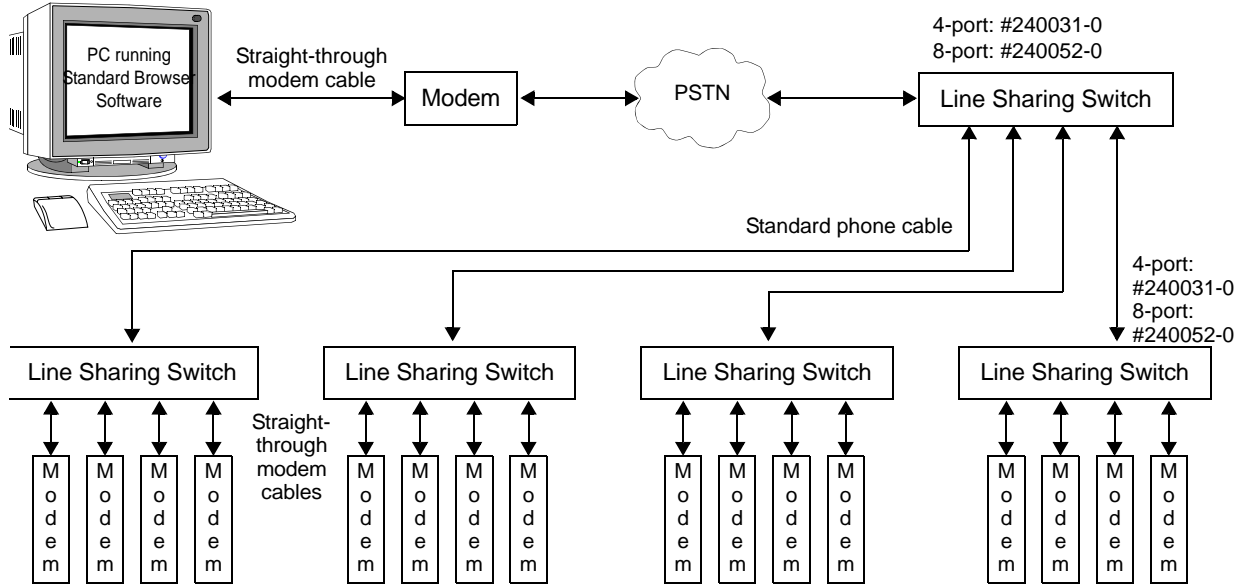




Figure 7-58 Cascading Line Sharing Switches



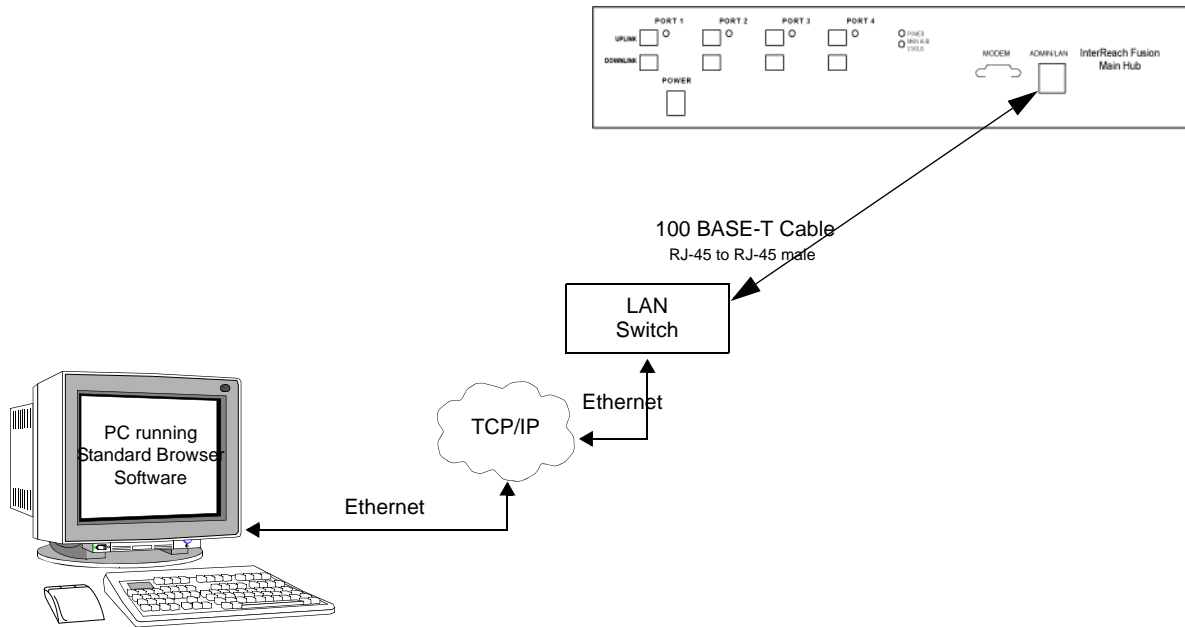
### 7.8.5 Ethernet RF Modem

Fusion Wideband can also use an Ethernet-based RF modem. Just about any RF modem will work, although modems that support Port Address Translation are best.

### 7.8.6 Ethernet LAN Connection

An Ethernet LAN connection can be used to communicate between the PC and Fusion Wideband. Testing was performed with an Linksys 4-port LAN switch.

Figure 7-59 OA&M Connection Using Ethernet and ENET/232 Serial Hub

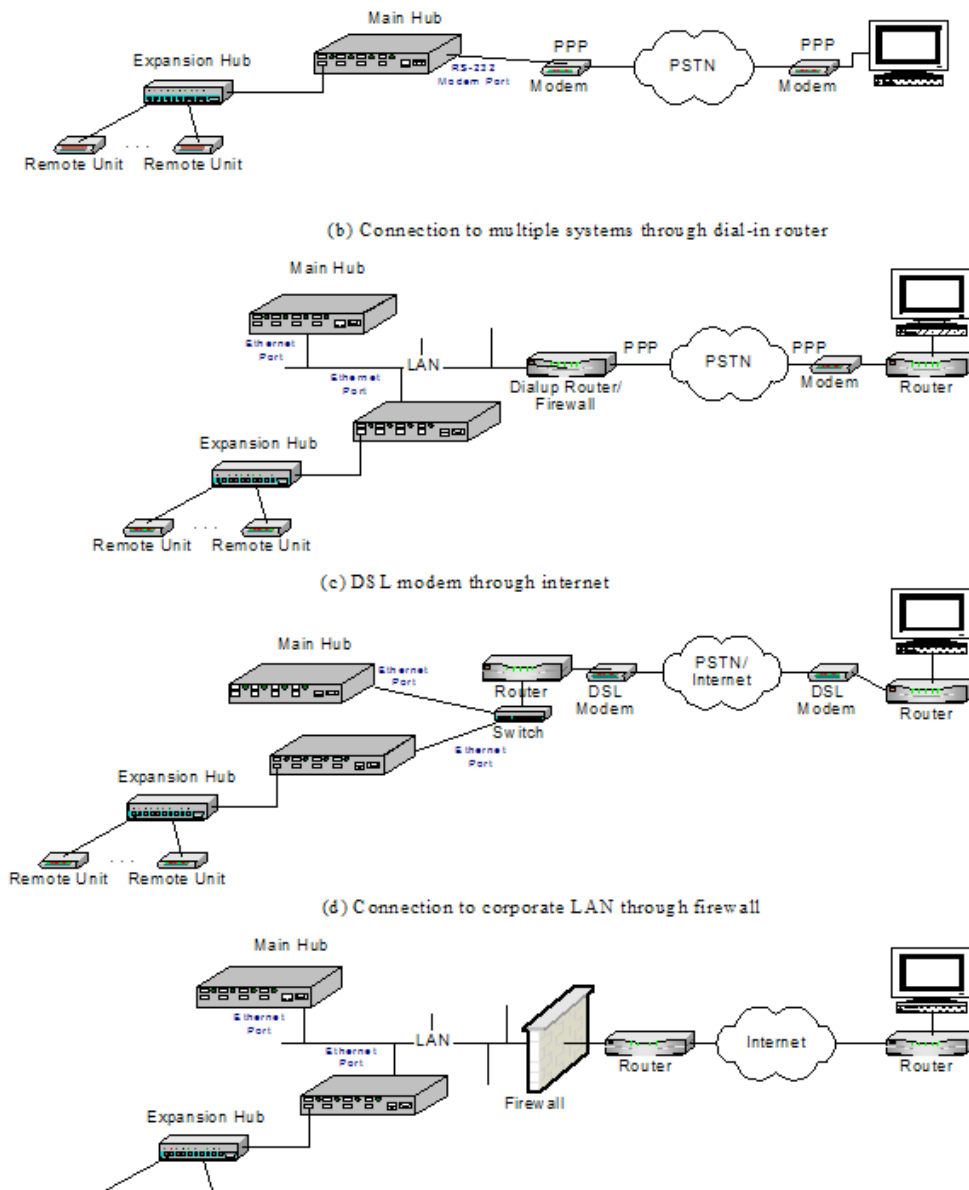


### 7.8.7 SNMP Interface

Faults and warnings can also be diagnosed with SNMP using a standard (NMS) network management system (optional). SNMP resident software in Fusion Wideband provides SNMP interactions for Traps and Notification.

The Fusion Wideband SNMP includes a MIB for integrating into the Network Management System (NMS) and supports SNMPv1 and SNMPv2c.

Figure 7-60 Fusion Wideband SNMP Configuration Options





# Replacing Fusion Wideband Components

---

This section contains the following subsections:

- Section 8.1 Replacing an RAU ..... 8-1
- Section 8.2 Replacing a Fusion Wideband Expansion Hub ..... 8-3
- Section 8.3 Replacing a Fusion Wideband Main Hub ..... 8-4

---

## 8.1 Replacing an RAU

Be aware that the new RAU must support the same bands as the one you are replacing. If the RAU is of the wrong band combination, it will not operate properly in the system.

### Replacing an RAU

1. Using AdminBrowser, log in and click SYSTEM INFORMATION.
2. Click SHOW SYSTEM TREE, select Fusion Wideband Main Hub, and click GET SYSTEM INFORMATION.

All system settings for Hubs and RAUs will be displayed. Write down or save the Uplink and Downlink Attenuation setting so you can set the new RAU with the same settings.

3. Click CANCEL to close the window.
4. Verify that the new RAU is of the same frequency bands as the one replaced.
5. Disconnect the CATV cable and antenna cable from the unit to be replaced.
6. Install the new RAU.
7. Connect the antenna cable and then the CATV cable to the new RAU.
8. Click SYSTEM CONFIGURATION.
9. Click SHOW SYSTEM TREE.
10. Select the Fusion Wideband RAU replaced and click EDIT UNIT PROPERTIES.

11. Set the attenuation of each band as the old RAU was programmed and click **SAVE PROPERTIES**.

### ✓ **Perform System Test**

When convenient, perform System Test to optimize performance.

**During System Test, the entire system is temporarily off-line and no RF is being transmitted.**

### ✓ **Checking the RAU's LEDs**

1. The RAU's **LINK** and **ALARM** LEDs should blink (green/red) on power up.
  - If the LEDs do not blink on power up, replace the RAU.
2. After several seconds both LEDs should change to green, which indicates that the unit has been successfully replaced, there is communication with the Hub, and the RAU band is correct.
  - a. If the **LINK** LED remains green and the **ALARM** LED remains red, verify that the RAU model is correct for the intended frequency band.
    - Disconnect the cable and then reconnect it once; doing this more than once will not change the result.
  - b. If both LEDs still don't change to green, use AdminBrowser to determine the exact nature of the fault and see a recommendation of how to correct it.
  - c. If both LEDs turn red (after 90 seconds), the Hub has terminated communications.

## 8.2 Replacing a Fusion Wideband Expansion Hub

### ✓ Replacing a Fusion Wideband Expansion Hub

1. Turn off the power to the Expansion Hub.
2. Disconnect all CATV cables, both fiber cables, and the AC power cord.
3. Replace the Expansion Hub with a new one.
4. Connect the AC power cord, all CATV cables, and both fiber cables – remembering to clean and correctly connect the uplink and downlink fiber.
5. Turn on the power to the Expansion Hub.

### ✓ AdminBrowser Tasks

- The Main Hub automatically issues the band setting.
- When convenient, use AdminBrowser to perform System Test in order to optimize performance.

**During System Test, the entire system is temporarily off-line and no RF is being transmitted. For a fully loaded system (one Main Hub, four Expansion Hubs, and 32 RAUs), it can take up to 1.5 minutes to complete the test.**

### ✓ Checking the Expansion Hub's LEDs

- The LEDs should blink through all states on power up.
  - If the LEDs do not blink on power up, replace the Expansion Hub.
  - If the LEDs do not illuminate at all, make sure the AC power cable is connected.
- The **UL STATUS** and **DL STATUS** LEDs should be green.
- The **E-HUB STATUS** and **POWER** LEDs should be green.
- For each CATV port that has an RAU connected the LEDs should be green.  
It can take several seconds for each CATV connection for the LEDs to display properly.

---

**NOTE:** Refer to Section 9 for troubleshooting using the LEDs.

---

## 8.3 Replacing a Fusion Wideband Main Hub

You must record the system configuration settings from the old Fusion Wideband Main Hub's memory before replacing the unit. You will program the new Main Hub with this information. If the Main Hub is programmed incorrectly, the system will not work. If the Hub to be replaced is not functioning and you cannot use AdminBrowser, get the configuration settings from the As-Built Document that was created as part of the original installation.

### ✓ Replacing a Fusion Wideband Main Hub

1. Using AdminBrowser, log in, click SYSTEM INFORMATION, click SHOW SYSTEM TREE, select Fusion Wideband Hub, click GET SYSTEM INFORMATION.
2. Turn off the power to the Fusion Wideband Main Hub.
3. Disconnect all cables and the AC power cord.
4. Replace the Main Hub with a new one.
5. Connect the AC power cord and all cables.
6. Connect the crossover Ethernet cable to the PC and then to the Main Hub's front panel 100Base-T connector. ADMIN/LAN port)
7. Start the standard browser on the PC to communicate with AdminBrowser software.
8. Turn on the power to the Main Hub.
9. Observe the LEDs after turning on the power.

All the LEDs blink during the initial power up sequence. All LEDs should turn green after the power on sequence is complete. Power up sequence takes between 1 and 2 minutes depending on the number of RAUs.

### ✓ Configure the New Fusion Wideband Main Hub

1. Using AdminBrowser and log in to the Main Hub.
2. Click SYSTEM CONFIGURATION.
3. Click SET DATE/TIME and enter the current date and time.
4. Click SET DATE/TIME.
5. Follow the instructions to eventually reboot the system to set the date and time.
6. Using AdminBrowser, log in and click SYSTEM CONFIGURATION.
7. Click INSTALL SYSTEM.
8. Set the new Main Hub parameters from the old Main Hub and click INSTALL SYSTEM (that is, uplink and downlink gain, system labels, and so on).
9. Follow the instructions to perform a System Test.



10. Click SYSTEM CONFIGURATION and click on SETUP NETWORK CONNECTION OR MODEM CONNECTION if the Main Hub has Network or Modem equipment connected to it.

**During System Test, the entire system is temporarily off-line and no RF is being transmitted.**

### **Checking the Main Hub's LEDs**

- The LEDs should blink through a 5-second test on power up.
  - If the LEDs do not blink on power up, replace the Main Hub.
  - If the LEDs do not illuminate at all, make sure the AC power cable is connected.
- For each fiber optic port that has a connected Expansion Hub, which has been programmed with a band, the **PORT LED** should be green.
- Refer to Section 9.3, "Troubleshooting," on page 9-3 for more LED states.

---

**NOTE:** If there is no communication between the Main Hub and the Expansion Hubs, use the AdminBrowser to isolate system problems.

---



# Maintenance, Troubleshooting, and Technical Assistance

---

This section contains the following subsections:

- Section 9.1 Service . . . . . 9-1
- Section 9.2 Maintenance . . . . . 9-2
- Section 9.3 Troubleshooting . . . . . 9-3
- Section 9.4 Troubleshooting CATV . . . . . 9-10
- Section 9.5 Technical Assistance . . . . . 9-10

---

## 9.1 Service

There are no user-serviceable parts in any of the Fusion Wideband components. Faulty or failed components are fully replaceable through ADC. All units should be replaced and returned to the factory for service if needed.

Address	2540 Junction Avenue San Jose, California 95134-1902 USA
Phone	1-408-952-2400
Fax	1-408-952-2410
Help Hot Line	1-800-530-9960 (U.S. only) +1-408-952-2400 (International)
Web Address	<a href="http://www.adc.com">http://www.adc.com</a>
e-mail	<a href="mailto:service@lgcwireless.com">service@lgcwireless.com</a>

## 9.2 Maintenance

Keep the fiber ports clean and free of dust. No other periodic maintenance of the Fusion Wideband equipment is required.

### To clean the fiber ports:

You can clean the Hub's fiber ports using canned compressed air or isopropyl alcohol and cotton swabs.

### Considerations:

- If you use compressed air:
  - The air must be free of dust, water, and oil.
  - Hold the can level during use.
- If using isopropyl alcohol and foam-tipped swab:
  - Use only 98% pure or more alcohol.

### Procedure using compressed air:

1. Remove the connector's dust cap.
2. Spray the compressed air away from the unit for a few seconds to clean out the nozzle and then blow dust particles out of each fiber port.

### Procedure using isopropyl alcohol:

1. Remove the connector's dust cap.
2. Dip a 2.5mm lint-free, foam-tipped swab in isopropyl alcohol and slowly insert the tip into the connector.
3. Gently twist the swab to clean the connector.
4. Insert a dry swab to dry the connector.

Additionally, you can use compressed air after the alcohol has completely evaporated.

## 9.3 Troubleshooting

---

**NOTE:** Fusion Wideband has no user-serviceable parts. Faulty or failed units are fully replaceable through ADC.

---

Sources of potential problems include:

- Faulty cabling/connector
  - Malfunction of one or more Fusion Wideband components
  - Antenna, base station, or repeater problem
  - External RF interface
  - Tripped circuit breaker
  - Equipment is not grounded
  - Using an Ethernet crossover cable that does not support full hardware handshaking when using AdminBrowser
- 

**NOTE:** Faulty cabling is the cause of a vast majority of problems. All CATV 75 Ohm cable should be tested to TIA-570-B specifications. **The RAU will be damaged if the cable connector is not installed properly.**

---

You must use AdminBrowser for troubleshooting the system, use the LEDs only as backup or for confirmation.

If you cannot determine the cause of a problem after following the recommended procedures, call ADC customer help hot line:

1-800-530-9960 (U.S. only)  
 +1-408-952-2400 (International)

Or, email us at [service@lgcwireless.com](mailto:service@lgcwireless.com).

Please provide the following information:

- Serial number of the unit
- Description of the problem
- Using AdminBrowser 1.00, access Special Features, then the Get Service Information window. Save and email this file to ADC.
- What is the length of the CATV cable? What type is it (for example RG-6)?
- Status of the LEDs on the unit
- Was the unit power cycled?

### 9.3.1 Troubleshooting Using AdminBrowser

Use AdminBrowser software to determine the current faults and warnings for all of the units in the system. To troubleshoot, start with the Fusion Wideband Main Hub's faults AND warnings, then proceed to each of the Expansion Hubs, finishing with each of the RAUs.

---

**NOTE:** AdminBrowser v1.00 displays events (faults, warnings, or status messages) depending on your view preference. To change your view preference, refer to Section 3.3.2, "View Preference," on page 3-10.

---

#### System Troubleshooting

Using AdminBrowser, click SYSTEM INFORMATION, then click GET FAULTS, WARNINGS AND STATUSES. This gives the present status of the system, depending upon View Preferences for all components.



Faults usually impact service; warnings may impact service; status messages contain information that should not be ignored, but indicate conditions that do not generally impact service.

---

**NOTE:** System commands can take longer to execute compared to component commands.

---

---

**NOTE:** This RAU icon  indicates there is fault on the RAU. This icon  indicates a disconnected device. You cannot request status on a disconnected device.

---

#### 9.3.1.1 Troubleshooting Recommendations

Some actions that you can take, depending on the device fault or warning include, are as follows:

- a. Hardware faults on Expansion Hub.
  - Try swapping fiber with another Expansion Hub at the Main Hub.
  - Try cleaning the fiber and the fiber ports with alcohol foam tip swab and compressed air. See Section , "To clean the fiber ports:," on page -2.
  - Power cycle the Expansion Hub.

- b. Under Alarms, click CLEAR ALL DISCONNECTS at the Fusion Wideband Main Hub.
- c. Power cycle the Fusion Wideband Main Hub.
- d. RAU hardware faults. Try moving a working CATV to the suspect port and verifying that the RAU comes up OK.
- e. Try isolating the system components:
  - Check to see if the whole system is effected or a portion of the system.
  - If the whole system is effected, disconnect the DAS system from the RF source and see if the RF source is working.
  - Continue to isolate by disabling portions of the system. Under System Configuration, click SHOW SYSTEM TREE and select a component. Then click SET OUT OF SERVICE/SET IN SERVICE.

### 9.3.1.2 Fault/Warning/Status Indications

Once all of the units are powered on and the cable connections are made, the faults from each unit can be requested using AdminBrowser. Start with the Fusion Wideband Main Hub and work downstream.

Resolve all faults first and then check the warnings. Take appropriate action to resolve the faults, as indicated in the following tables. In cases where there is more than one possible cause, they are listed from the “most likely” to the “least likely” cause. Actions are listed in the order that they should be performed; not all actions may need to be done.

---

**NOTE:** If you have a red **STATUS** LED without a fault message, it probably indicates that the unit is locked out.

---

Refer to Appendix C for tables containing Fault, Warning, and Status messages and their meanings.

### 9.3.2 Troubleshooting Using LEDs

The following troubleshooting guide is from the perspective that all Fusion Wideband equipment is installed, their cables are connected, and they are powered on; it is assumed that the system was operating normally before the problem to be diagnosed occurred.

Always use AdminBrowser, if possible, to troubleshoot the system. The Fusion Wideband Main Hub and Expansion Hub LEDs are for backup troubleshooting. The RAU LEDs probably will not provide additional information for troubleshooting.

### 9.3.2.1 Troubleshooting Main Hub LEDs During Normal Operation

All of the Main Hub's LEDs should be green during normal operation. If any LEDs are red, get status using AdminBrowser to determine the exact cause and recommendations.

**Table 9-1 Troubleshooting Main Hub Port LEDs During Normal Operation**

During Normal Operation	Main Hub Port LEDs	State	Action	Impact
Expansion Hub Not Connected	PORT	Red	<p>If the Expansion Hub was disconnected accidentally, re-connect the cables. The LEDs should change to Green/Red (then Green/Green, after 20 seconds, if the Main Hub band has been programmed).</p> <p>When the Expansion Hub is to be removed from service permanently, use AdminBrowser's 'Clear All Disconnect Status' command to clear all disconnect states to no connect states.</p>	<p>The Expansion Hub was previously connected, but it is not currently connected; the Expansion Hub uplink cable disconnected.</p> <p>AdminBrowser clears all disconnects caused by installation as part of the clean-up process. After installation, power cycle the Main Hub or use AdminBrowser's "Clear All Disconnect Status" command.</p> <p>Changes the Main Hub's port LEDs to Off/Off.</p>
Expansion Hub Connected	PORT	Flashing Red (60 ppm)	Use AdminBrowser to determine the exact cause of the Main Hub's faults.	<p>Lost communication with Expansion Hub; could be Expansion Hub problem or fiber cable problem.</p> <p>The Expansion Hub communication problems delay MH responses to AdminBrowser commands, resulting in command time-outs. You can disconnect the offending Expansion Hub initially to obtain status from the rest of the system, then connect the Expansion Hub and resolve the communication problem.</p>
	PORT	Red	The Expansion Hub or connected RAU reports a fault condition; use AdminBrowser to determine the exact cause of the Expansion Hub and RAU's faults.	<p>Degraded performance or unit may be off-line.</p> <p>Depends on fault condition.</p>



**Table 9-2 Troubleshooting Main Hub Status LEDs During Normal Operation**

<b>During Normal Operation</b>	<b>Main Hub Status LEDs</b>	<b>State</b>	<b>Action</b>	<b>Impact</b>
At Any Time	<b>MAIN HUB STATUS</b>	Red	Use AdminBrowser to determine the exact cause of the fault. Power cycle one time. If the fault remains, replace the Main Hub.	Internal Main Hub fault.
			Use AdminBrowser to check if the Main Hub is commanded Out-of-Service (every Expansion Hub port status LED will be red as well). A power cycle will not clear a commanded Out-of-Service, you must use AdminBrowser to clear this state.	The Main Hub and all downstream units are off-line.
	<b>MAIN HUB STATUS</b>	Flashing Red (60ppm)	Reduce input signal power.	Signal compression.
At Any Time	<b>POWER</b>	Red	Replace the Main Hub.	One or more power supplies are out of specification.

### 9.3.2.2 Troubleshooting Expansion Hub LEDs During Normal Operation

- All of the Expansion Hub **LINK** and **E-HUB/RAU** LEDs that have RAUs connected should be Green/Green, indicating that the RAU is powered on, communication is established, and operation is normal.
- The **POWER**, **EHUB STATUS**, **DL STATUS**, and **UL STATUS** LEDs should all be Green.

**Table 9-3 Troubleshooting Expansion Hub Port LEDs During Normal Operation**

<b>During Normal Operation</b>	<b>Expansion Hub Port LEDs</b>	<b>State</b>	<b>Action</b>	<b>Impact</b>
RAU is not connected	<b>PORT</b>	Off	If the RAU was disconnected accidentally, re-connect the CATV cable. The Expansion Hub's port LEDs should change to Green/Red (then Green/Green, after 20 seconds, if the Main Hub is connected, powered on, and has band programmed).  Use AdminBrowser's "Clear All Disconnect Status" command if you are permanently removing the RAU from service. The Expansion Hub's port LEDs should change to Off/Off.	The RAU was previously connected, but it is not currently connected; the RAU cable is disconnected.
RAU is connected	<b>PORT</b>	Red	Disconnect/reconnect the CATV cable to force power-on reset to the RAU. If the port LEDs remain Red check for the exact cause of Expansion Hub faults using AdminBrowser.	Lost communications with the RAU. The RAU could have powered down due to over current; cable could have been damaged.
	<b>PORT</b>	Flashing Red (60 ppm)	The RAU reports a fault condition; check for the exact cause of Expansion Hub and RAU faults using AdminBrowser.	Depends on the fault condition.
	<b>PORT</b>	Flashing Red (60 ppm)	The Expansion Hub reports no connection, cable shorts, or a current port trap condition.	Expansion Hub communications with the RAU. The Expansion Hub is at fault. The cable could have been damaged. The cable leads may be shorted.

**Table 9-4 Troubleshooting Expansion Hub Status LEDs During Normal Operation**





During Normal Operation	Expansion Hub Status LEDs	State	Action	Impact
At Any Time	<b>UL STATUS</b>	Red	Check uplink fiber for optical loss. Power cycle Expansion Hub one time to check uplink laser.	No communications between the Main Hub and the Expansion Hub. Uplink laser failure.
	<b>DL STATUS</b>	Red	Check the downlink fiber for optical loss	No communications with the Main Hub.
	<b>E-H STATUS</b>	Red	If either the <b>UL STATUS</b> or the <b>DL STATUS</b> are also red, see above. Cycle power on the Expansion Hub. If fault remains, replace the Expansion Hub.	Internal Expansion Hub fault (including either of the above <b>UL STATUS</b> or <b>DL STATUS</b> states).

## 9.4 Troubleshooting CATV

The following table summarizes CATV problems, as reported by AdminBrowser if a cable is cut or miswired.

**NOTE:** Recommended minimum and maximum CATV cable lengths vary depending upon the type of CATV cable used. Refer to Section 6.1.2, “Cable and Connector Requirements,” on page 6-2.

**Table 9-5 Summary of CATV Cable Wiring Problems**

Problem Type	Message	Icon	Impact
Loose connector, shorted conductor or improper connection to the shield.	None		High phase noise, degraded signal on both Downlink and Uplink (high bit error rate)
	• No communication with RAUn		RAU unable to communicate with Hub, degraded performance or RAU off-line
	• Portn UL RF path loss is too high		Increased ripple in the uplink path, decreased UL gain, or no UL gain
	• The DL RF path loss is too high		Increased ripple in the downlink path, RAU off-line
	• RAUn over current or port short		RAU will not power on.

## 9.5 Technical Assistance

Call our help hot line for technical assistance:

1-800-530-9960 (U.S. only)  
 +1-408-952-2400 (International)

Please provide your name, phone number, e-mail address, and the following information. An ADC customer service representative will contact you with assistance.

- Company name
- End user name
- Type of system, model number, frequency
- Approximate time in service (warranty), sales order number
- Description of problem
- LED status
- AdminBrowser faults, warnings, and status messages

# Cables and Connectors

---

## A.1 75 Ohm CATV Cable

---

- Connects the Expansion Hub to the RAU(s)
- Transmits multiband (downlink) and receives (uplink) IF signals
- Delivers DC electrical power to the RAUs. The Fusion Wideband Hub's DC voltage output is 54V DC nominal. A current limiting circuit is used to protect the Hub if it reaches its current limit
- Carries configuration and status information
- Use 75 Ohm type-F connectors with captive centerpins
- Lengths:
  - RG-59:
    - Minimum: 0 meters (0 ft.)
    - Maximum: 130 meters (426 ft.)
  - RG-6:
    - Minimum: 0 meters (0 ft.)
    - Maximum: 140 meters (459 ft.)
  - RG-11:
    - Minimum: 0 meters (0 ft.)
    - Maximum: 235 meters (771 ft.)

Recommended minimum and maximum CATV cable lengths vary depending upon which CATV cable you use.

Be sure to test cable termination before installing the cable.

**CommScope CATV cable or equivalent is required:**

CommScope 20655V for RG-59. This cable is illustrated in Figure A-1.

CommScope 2279V for RG-6. This cable is illustrated in Figure A-2.

CommScope 2293K for RG-11. This cable is illustrated in Figure A-3.

Figure A-1 CommScope 2065V for RG-59

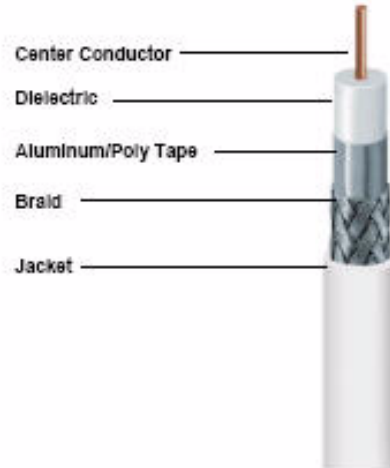
**CONSTRUCTION:**

**CENTER CONDUCTOR:**  
20 AWG Solid Copper (.0320" +/- .0003")

**DIELECTRIC:**  
Foamed Fluorinated Ethylene Propylene (FFEP)  
Dia. Over Dielectric: 0.135" +/- 0.004" Nom.

**SHIELD:**  
Foil: Aluminum/Poly Tape  
Braid: 34 AWG 7 End Tin/Copper  
96% Coverage  
Nom. Dia. 0.170"

**JACKET:**  
Flame Retardant Polyvinylchloride (PVC) (2065V)  
Kynar (2065K)  
Dia. Over Jacket: 0.207" +/- 0.002"  
Min. Avg. Jkt. Thickness: 0.016"  
Min. Spot: 0.012"



**ELECTRICAL PROPERTIES:**

**SPARKER TEST:** 2500 VAC

**DIELECTRIC STRENGTH:** Conductor to Shield – 3 Sec. @ 2500 VDC

**CAPACITANCE:** 16.1 pF/ft. Nom.

**IMPEDANCE:** 75.0 +/- 3 Ohms

**VELOCITY OF PROPAGATION:** 84.0% Nom.

**DCR:** Cond: 10.34 Ohms/1000 Ft. Nom.  
Shield: 2.7 Ohms/1000 Ft. Nom.

**SRL:** 23 dB (5 to 450 MHz) 100% Swept Tested  
15 dB (451 – 2400 MHz) 100% Swept Tested

**ATTENUATION:**

dB/100 Ft. (Nom.)	@ Frequency MHz
.30 dB	1 MHz
.54 dB	3.6 MHz
0.88 dB	10 MHz
2.16 dB	71.5 MHz
2.90 dB	135 MHz
4.16 dB	270 MHz
4.98 dB	360 MHz
7.61 dB	720 MHz

**MECHANICAL PROPERTIES:**

**MINIMUM BEND TEST:**  
Loaded: 20 Times Cable OD  
Unloaded: 10 Times Cable OD

**JACKET TEMP. RATING:**  
Temp: 60°C (2065V)  
125°C (2065K)

Figure A-2 CommScope 2279V for RG-6

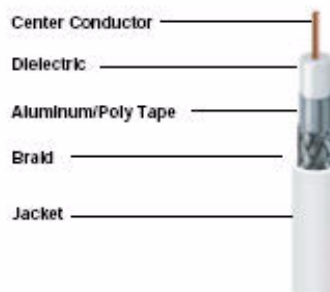
**CONSTRUCTION:**

**CENTER CONDUCTOR:**  
18 AWG Solid Copper

**DIELECTRIC:**  
Foamed Fluorinated Ethylene Propylene (FFEP)  
Dia. Over Dielectric: 0.170" +/- 0.004" Nom.

**SHIELD:**  
Foil: Aluminum/Poly Tape  
Braid: 34 AWG Tinned Copper  
95% Coverage  
Nom. Dia. 0.205"

**JACKET:**  
Plenum Polyvinylchloride (PL-PVC)  
Dia. Over Jacket: 0.237" +/- 0.004"  
Max. Avg. Jkt. Thickness: 0.016"  
Min. Spot: 0.013"



**ELECTRICAL PROPERTIES:**

**SPARKER TEST:** 4000 VAC

**DIELECTRIC STRENGTH:** Conductor to Shield – 3 Sec. @ 2500 VDC

**CAPACITANCE:** 16.0 pF/ft.

**IMPEDANCE:** 76.0 +/- 2 Ohms

**VELOCITY OF PROPAGATION:** 94.0% Nom.

**DCR:** 6.5 Ohms/1000 ft.

**SRL:** 23 dB (1 to 450 MHz) 100% Swept Tested  
15 dB (451 – 2400 MHz) 100% Swept Tested

**ATTENUATION:**

dB/100 Ft. (Nom.)	@ Frequency MHz
.26 dB	1 MHz
.47 dB	3.6 MHz
.70 dB	10 MHz
1.65 dB	71.5 MHz
2.39 dB	135 MHz
3.40 dB	270 MHz
4.08 dB	360 MHz
6.05 dB	720 MHz

**MECHANICAL PROPERTIES:**

**MINIMUM BEND TEST:**  
Loaded: 20 Times Cable OD  
Unloaded: 10 Times Cable OD

**JACKET TEMP. RATING:**  
Temp: 60°C

**Figure A-3 CommScope 2293K for RG-11**

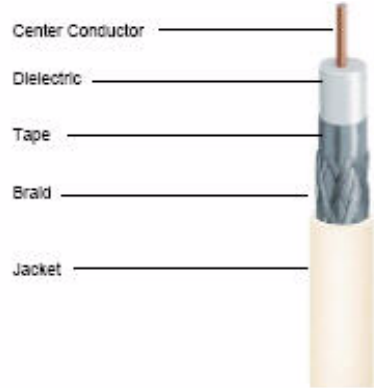
**CABLE CONSTRUCTION:**

**CENTER CONDUCTOR:**  
 14 AWG Solid Copper  
 Nom. Dia: 0.0641"

**DIELECTRIC:**  
 Foam FEP  
 Dia. over Dielectric: 0.280" Nom.

**SHIELD:**  
 Tape: Aluminum/Poly  
 Braid: 34 AWG Tinned Copper  
 95% Coverage  
 Nom. Dia. 0.307"

**JACKET:**  
 Kynar Flex  
 Dia. over Jacket: 0.347" +/- 0.006"  
 Nominal Jacket Thickness: 0.020"  
 Minimum Spot: 0.016"



**ELECTRICAL PROPERTIES:**

**SPARKER TEST:** 5000 VAC

**DIELECTRIC STRENGTH:** Conductor to Shield: 4000 VDC

**CAPACITANCE:** 16.0 pF./FT. Nom.

**IMPEDANCE:** 75.0 +/- 3.0 Ohms

**VELOCITY OF PROPAGATION:** 84.0% Nom.

**DCR:** Conductor: 2.9 Ohms/1000 Ft. Nom.  
 Shield: 1.7 Ohms/1000 Ft. Nom.

**SRL:** 23dB (10 thru 1500 MHz) 100% Swapt Tested

**MECHANICAL PROPERTIES:**

**MINIMUM BEND RADIUS:**  
 Loaded: 20 Times Cable  
 Unloaded: 10 Times Cable

**CABLE TEMP. RATING:**  
 Temp: 125°C

**ATTENUATION:**

dB/100 FT. (NOM.)	@ FREQUENCY MHz
0.09 dB	1 MHz
0.45 dB	10 MHz
0.90 dB	50 MHz
1.28 dB	100 MHz
1.85 dB	200 MHz
2.75 dB	400 MHz
3.92 dB	700 MHz

**NOTE:** ADC requires solid copper center conductor CATV cable for proper DC voltage to the RAU and maximum distances.



---

Use the following connectors and tools to prepare the cable ends:

CommScope cable part number: 2065V

Canare part number: F connector FP-C4F

Crimp Tool TC-1, Crimp Die TCD-4C, Cable Strip preparation tool TS100E

CommScope cable part number: 2279V

Canare part number: F connector FP-C55A

Crimp Tool TC-1, Crimp Die TCD-35CA, Cable Strip preparation tool TS100E

CommScope cable part number: 2293V

Canare part number: F connector FP-C71A

Crimp Tool TC-1, Crimp Die TCD-7CA, Cable Strip preparation tool TS100E

If the maximum distance is not required, then copper-clad over steel-center conductor cable may be used to reduce cable costs.

Table A-2 shows CommScope cable choices of plenum, non-plenum, solid copper conductor, and copper-clad over-steel conductor cable with their part numbers and maximum distances.

**Table A-1 System Gain (Loss) Relative to CATV Cable Length**

Cable Type	Comm-Scope Part Number	Plenum Rated	Solid Copper Conductor	Copper Clad Conductor	Zero-loss RF Maximum Length (meters)	Distance Where RF is 10dB Below Input RF (meters)
<b>RG-59</b>						
	2065V	Yes	X		130	180
	2022V	Yes		X	100	100*
	5572R	No		X	95	95*
	5565	No	X		130	180
<b>RG-6</b>						
	2279V	Yes	X		140	190
	2275V	Yes		X	140	150*
	5726	No		X	140	140*
	5765	No	X		140	190
<b>RG-11</b>						
	2293K	Yes	X		235	320
	2285K	Yes		X	235	300*
	5913	No		X	235	300*

\* Exceeding the distance of copper-clad cable will result in the attached RAU becoming non-functional. If the distance of a cable run is at its maximum and is of concern, ADC recommends the use of solid copper cable to ensure successful operation.

## A.2 Fiber Optical Cables

- Connects the Main Hub to Expansion Hub(s)
- Transmits (downlink) and receives (uplink) optical signals
- Carries configuration and status information
- Use industry-standard 62.5µm/125µm MMF or Corning SMF-28 fiber, or equivalent.
- SC/APC (angle-polished) connectors are required throughout the fiber network (port-to-port), including fiber distribution panels

- Distances:
  - Multi-mode Fiber: up to 500 m (1,640 ft) – 3 dB optical loss maximum
  - Single-mode Fiber: up to 6 km (19,685 ft) – 3 dB optical loss maximum

---

### A.3 Coaxial Cable

- Connects a Fusion Wideband Hub to a repeater or base station (N-type connectors)
- Connects an RAU to a passive antenna (N-type connectors)

---

### A.4 Standard Modem Cable

This cable (PN 4028-10) connects a modem to the Fusion Wideband Hub's front panel serial port.

**Figure A-1 Standard Modem Cable Pinout**

---

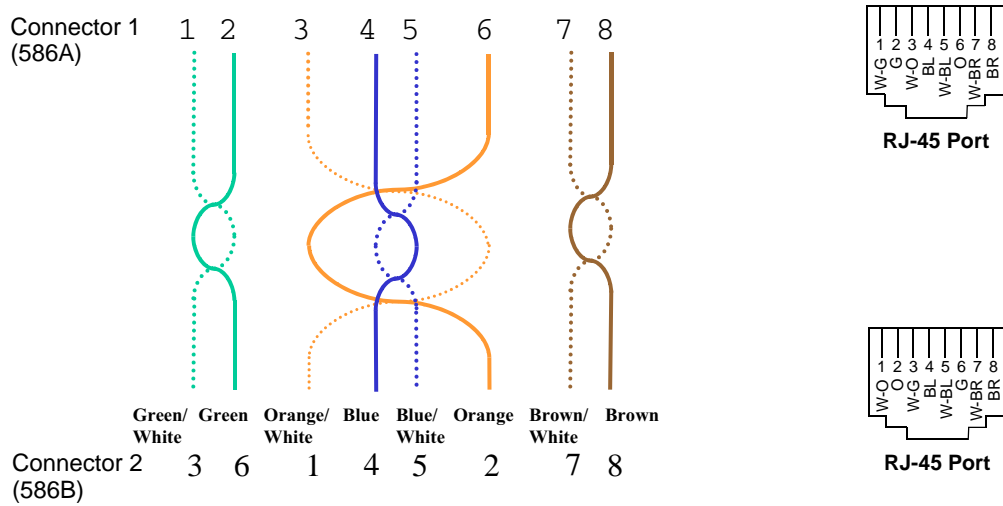
DB-9 Connector Pin		DB-25 Connector Pin
1	↔	8
2	↔	3
3	↔	2
4	↔	20
5	↔	7
6	↔	6
7	↔	4
8	↔	5
9	↔	22

---

## A.5 TCP/IP Cross-over Cable

A TCP/IP cross-over cable (PN 4069-ADB) is used to connect a standard browser PC to the AdminBrowser with a Fusion Wideband Hub. A cable is included with the Fusion Wideband Hub. The pinouts for this cable are illustrated in Figure A-2.

**Figure A-2 Wiring Map for TCP/IP Cable**



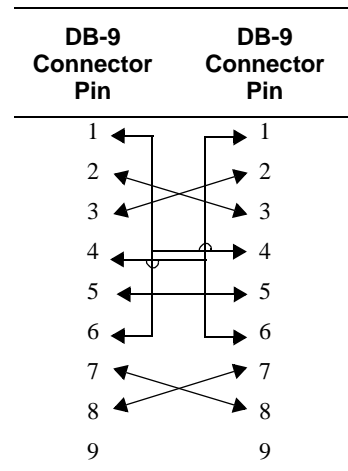
## A.6 DB-9 to DB-9 Null Modem Cable

Use a DB-9 female to DB-9 female null modem cable to connect the craft person's PC/Laptop to the RS-232 port on the front of the Fusion Wideband Hub for IP address configuration. Table A-2 lists the cable pinout and Figure A-3 shows a diagram of its wiring.

**Table A-2 DB-9 Female to DB-9 Female Null Modem Cable Pinout**

From	Signal	To	Signal
P1-4	DTR	P2-6, P2-1	DSR, DCD
P1-6	DSR	P1-1, P2-4	DCD, DTR
P1-3	TXD	P2-2	RXD
P1-2	RXD	P2-3	TXD
P1-5	GND	P2-5	GND
P1-7	RTS	P2-8	CTS
P1-8	CTS	P2-7	RTS
P1-9	N/C	N/C	N/C

**Figure A-3 DB-9 Female to DB-9 Female Null Modem Cable Diagram**



Note that for each DB-9 connector, pins 1 and 6 are tied together and sent to pin 4 of the opposite connector, providing the required handshake signals.



---

**B.1 Fusion Wideband System Approval Status**

InterReach Fusion Wideband has been approved as shown below.

**800 SMR/iDEN Products**

- Safety: UL, CSA, CB Scheme certificate to IEC 60950, 3rd Edition, and IEC 60950-1, 1st Edition, with all national deviations.
- EMC: FCC part 15 class A
- Radio: FCC part 90

**850 Cellular Products**

- Safety: UL, CSA, CB Scheme certificate to IEC 60950, 3rd Edition, and IEC 60950-1, 1st Edition, with all national deviations.
- EMC: FCC part 15 class A
- Radio: FCC part 22

**1800 DCS Products**

- Safety: UL, CSA, CB Scheme certificate to IEC 60950, 3rd Edition, and IEC 60950-1, 1st Edition, with all national deviations.
- EMC: EN 301 489-8 V1.2.1
- Radio: EN 301 502 V8.1.2

---

### **1900 PCS Products**

- Safety: UL, CSA, CB Scheme certificate to IEC 60950, 3rd Edition, and IEC 60950-1, 1st Edition, with all national deviations.
- EMC: FCC part 15 class A
- Radio: FCC part 24

### **2100 UMTS Products**

- Safety: UL, CSA, CB Scheme certificate to IEC 60950, 3rd Edition, and IEC 60950-1, 1st Edition, with all national deviations.
- EMC: EN 301 489-23 V1.2.1
- Radio: EN 301 908-11 V2.3.1

### **1700/2100 AWS Products**

- Safety: UL, CSA, CB Scheme certificate to IEC 60950, 3rd Edition, and IEC 60950-1, 1st Edition, with all national deviations.
- EMC: FCC part 15 class A
- Radio: FCC part 22, part 24, part 27

### **2500 WiMAX Products**

- Safety: UL, CSA, CB Scheme certificate to IEC 60950, 3rd Edition, and IEC 60950-1, 1st Edition, with all national deviations.
- EMC: FCC part 15 class A
- Radio: FCC part 27

### **InterReach Fusion Wideband Main Hub and Expansion Hub**

- Safety: UL, CSA, CB Scheme certificate to IEC 60950-1, First Edition, with all national deviations.
- EMC: CISPR 22A
- EMC: CISPR 24

---

**NOTE:** For Canadian customers, the Manufacturer's rated output power<sup>1</sup> of this equipment is for single carrier operation. For situations when multiple carrier signals are present, the rating would have to be reduced by 3.5 dB,

---

1. "Manufacturer's rated output power" refers to Fusion Wideband's downlink P1dB. The power per carrier tables take into account this power reduction for multiple carriers.



---

especially where the output signal is re-radiated and can cause interference to adjacent band users. This power reduction is to be by means of input power or gain reduction and not by an attenuator at the output of the device.

---

**NOTE:** This device complies with Part 15 of the FCC Rules. Operation is subject to the following two conditions: (1) this device may not cause harmful interference, and (2) this device must accept any interference received, including interference that may cause undesired operation.

---

## B.2 Human Exposure to RF

The U.S. Federal Communications Commission (FCC) has developed guidelines for evaluation of human exposure to RF emissions. The guidelines incorporate limits for Maximum Permissible Exposure (MPE) for power density of transmitters operating at frequencies between 300 kHz and 100 GHz. Limits have been set for portable, mobile, and fixed equipment. ADC products fall in the category of fixed equipment; products intended to be permanently secured and exposures are evaluated for distances greater than 20cm (7 7/8”). Portable devices fall into exposures of less than 20cm, are SAR evaluations are used.

Antenna gain is restricted to 1.5 W ERP (2.49 W EIRP) in order to satisfy RF exposure compliance requirements. If higher than 1.5 W ERP, routine MPE evaluation is needed. The antennas should be installed to provide at least 20 cm from all persons to satisfy MPE requirements of FCC Part 2, 2.1091.

Basic MPE evaluation is performed by taking the maximum power output of the equipment, the gain of the antenna to be used, and distance from the antenna, referenced in FCC OET Bulletin 65 “*Evaluation Compliance with FCC Guidelines for Human Exposure to Radio Frequency for Electric Fields*”.

ADC products transmit well below the FCC power density limits. FCC defines power output limits at 20cm distance for various frequency ranges:

- Over 300 MHz to 1.5 GHz the limit is determined by frequency/1500
- Above 1.5 GHz the limit is 1mW/cm<sup>2</sup>

The basic equation for determining power density is:

$$S = PG / 4\pi R^2$$

Where S is power density in mW/cm<sup>2</sup>

---

**PG**, the transmitted power from the antenna identified as EIRP (Equivalent Isotropically Radiated Power), is the product of power output of device and antenna gain, in mW.

**R** is the distance of interest from the antenna.

### **Typical Installation Example:**

Assuming an antenna is placed on a 10 foot ceiling, for a person 6 feet tall, the distance from antenna to body is 4 feet (112 cm.).

For a PCS 1900 remote unit, the maximum power output, according to the power table in Section 6.3 Maximum Output Power per Carrier on page 6-4, is 16.5 dB.

Assuming a 7 dBi antenna is used, PG in the equation is equal to 23.5 dB (224 mW) EIRP.

Using  $S = PG/4\pi R^2$

$$S = 224/(4 \times 3.14) \times (112)^2 = 0.001 \text{ mW/cm}^2$$

Also, assuming a minimum distance of 20 cm according to FCC regulations”

$$S = 224/(4 \times 3.14) \times (20)^2 = 0.04 \text{ mW/cm}^2$$

# Faults, Warnings, Status Tables for Fusion, Fusion Wideband, Fusion SingleStar

---

This appendix contains the following sections:

- Section C.1 Faults Reported by Main Hubs . . . . . C-1
- Section C.2 Faults Reported for System CPU . . . . . C-5
- Section C.3 Faults for Expansion Hubs . . . . . C-6
- Section C.4 Faults for RAUs . . . . . C-9
- Section C.5 Messages for Main Hubs . . . . . C-10
- Section C.6 Messages for System CPUs . . . . . C-15
- Section C.7 Messages for Expansion Hubs . . . . . C-16
- Section C.8 Messages for RAUs . . . . . C-19

The following tables contain messages for all versions of firmware, but all messages are not displayed by a given firmware version.

---

## C.1 Faults Reported by Main Hubs

Faults indicate service-impacting conditions and should be given immediate attention.

Once all of the units are powered on and the cable connections are made, the faults from each unit can be requested using AdminBrowser. Start with the Fusion or Fusion Wideband Main Hub and work downstream.

Resolve all faults first and then check the warnings. Take appropriate action to resolve the faults, as indicated in the following tables. In cases where there is more than one possible cause, they are listed from the “most likely” to the “least likely” cause. Actions are listed in the order that they should be performed; not all actions may need to be done.

**NOTE:** If you have a red **STATUS** LED without a fault message, it probably indicates that the unit is locked out.

**Table C-1 Fault Messages for Main Hubs**

<b>Message Number</b>	<b>Description</b>	<b>Reason/Action</b>
{MF01}	Software error occurred and recovered.	If this happens repeatedly, replace the Hub.
{MF02}	Software error occurred and recovered.	If this happens repeatedly, replace the Hub.
{MF03}	Software error occurred and recovered.	If this happens repeatedly, replace the Hub.
{MF04}	Software reset occurred and recovered, or firmware download.	If this happens repeatedly, replace the Hub.
{MF05}	Software error occurred and recovered.	If this happens repeatedly, replace the Hub.
{MF06}	Problem detected in the Hub. Internal communication reset.	Contact ADC Support for more information.
{MF07}	Hub power cycle.	Hub power cycle.
{MF08}	Internal communications failure.	No internal communications in preceding 15 minutes.
{MF09}	Hardware Reset.	Commanded hardware power on reset
{MF10}	Band not programmed.	Use AdminBrowser to program the band.
{MF11}	Hardware failure (DL Pilot PLL).	Cycle power once. If fault persists, replace the Hub
{MF12}	Hardware failure (DL Pilot Too High).	Cycle power once. If fault persists, replace the Hub.
{MF13}	Hardware failure (DL Pilot Too Low).	Cycle power once. If fault persists, replace the Hub.
{MF14}	Hardware failure (54 VDC).	54 VDC power supply is out of range, replace the Hub
{MF15}	Hardware failure (RF VDC Power).	Loss of DC power to RF circuits, replace the Hub.
{MF16}	Self Lockout (All Bands).	Hub has shutdown the system due to an internal fault. System is offline.
{MF17}	Hardware failure (DL PLL Band 1).	Cycle power once. If fault persists, replace the Hub.
{MF18}	Hardware failure (UL PLL Band 1).	Cycle power once. If fault persists, replace the Hub
{ML19}	Commanded Out-of-service (Band 1).	Band 1 commanded out-of-service by User.
{MF20}	Hardware failure (UL1 LO2 Band 1).	Cycle power once. If the fault persists, replace the Hub.
{MF21}	Problem detected in the Hub.	Contact ADC Support for more information.
{MF22}	Problem detected in the Hub.	Contact ADC Support for more information.
{MF23}	Problem detected in the Hub	Contact ADC Support for more information.
{MF24}	Problem detected in the Hub.	Contact ADC Support for more information.
{MF25}	Hardware failure (DL PLL Band 2).	Cycle power once. If fault persists, replace the Hub.
{MF26}	Hardware failure (UL PLL Band 2).	Cycle power once. If fault persists, replace the Hub.
{ML27}	Commanded Out-of-service (Band 2).	Band 2 commanded out-of-service by User.
{MF28}	Problem detected in the Hub.	Contact ADC Support for more information.
{MF29}	Problem detected in the Hub.	Contact ADC Support for more information.
{MF30}	Problem detected in the Hub.	Contact ADC Support for more information.
{MF31}	Problem detected in the Hub.	Contact ADC Support for more information.
{MF32}	Problem detected in the Hub.	Contact ADC Support for more information.

**Table C-1 Fault Messages for Main Hubs (continued)**

<b>Message Number</b>	<b>Description</b>	<b>Reason/Action</b>
{MF33}	Hardware failure (DL PLL Band 3).	Cycle power once. If fault persists, replace the Hub.
{MF34}	Hardware failure (UL PLL Band 3).	Cycle power once. If fault persists, replace the Hub.
{ML35}	Commanded Out-of-service (Band 3).	Band 3 commanded out-of-service by User.
{MF36}	Hardware failure (638 MHz PLL).	Cycle power once. If fault persists, replace the Hub.
{MF37}	Hardware failure (656 MHz PLL).	Cycle power once. If fault persists, replace the Hub.
{MF38}	Problem detected in the Hub.	Contact ADC Support for more information.
{MF39}	Problem detected in the Hub.	Contact ADC Support for more information.
{MF40}	Problem detected in the Hub.	Contact ADC Support for more information.
{MF41}	Hardware failure (Optical Power Out).	Cycle power once. If the fault persists, replace the Hub.
{MF42}	Unable to sync with TDD frame (Band 1).	Check input signal and/or user TDD settings.
{MF43}	Unable to sync with TDD frame (Band 2).	Check input signal and/or user TDD settings.
{MF44}	Unable to determine number of TDD symbols (Band 1).	Make sure that the WiMAX signal has a valid number of downlink symbols. If the value is okay, try selecting a fixed number of symbols.
{MF45}	Unable to determine number of TDD symbols (Band 2).	Make sure that the WiMAX signal has a valid number of downlink symbols. If the value is okay, try selecting a fixed number of symbols.
{MF46}	Problem detected in the Hub.	Contact ADC Support for more information.
{MF47}	Problem detected in the Hub	Contact ADC Support for more information.
{MF48}	Problem detected in the Hub.	Contact ADC Support for more information.
{MD129}	Port 1 Disconnected.	Unit is disconnected.
{MD130}	Port 2 Disconnected.	Unit is disconnected.
{MD131}	Port 3 Disconnected.	Unit is disconnected.
{MD132}	Port 4 Disconnected.	Unit is disconnected.
{MD133}	Port 5 Disconnected.	Unit is disconnected.
{MD134}	Port 6 Disconnected.	Unit is disconnected.
{MD135}	Port 7 Disconnected.	Unit is disconnected.
{MD136}	Port 8 Disconnected.	Unit is disconnected.
{MC137}	Port 1 No Communications.	No communications with remote unit.
{MC138}	Port 2 No Communications.	No communications with remote unit.
{MC139}	Port 3 No Communications.	No communications with remote unit.
{MC140}	Port 4 No Communications.	No communications with remote unit.
{MC141}	Port 5 No Communications.	No communications with remote unit.
{MC142}	Port 6 No Communications.	No communications with remote unit.
{MC143}	Port 7 No Communications.	No communications with remote unit.
{MC144}	Port 8 No Communications.	No communications with remote unit.
{MT145}	Port 1 Cable Fault.	Possible electrical short in the coax cable, or RAU problem.
{MT146}	Port 2 Cable Fault.	Possible electrical short in the coax cable, or RAU problem.
{MT147}	Port 3 Cable Fault.	Possible electrical short in the coax cable, or RAU problem.

**Table C-1 Fault Messages for Main Hubs (continued)**

<b>Message Number</b>	<b>Description</b>	<b>Reason/Action</b>
{MT148}	Port 4 Cable Fault.	Possible electrical short in the coax cable, or RAU problem.
{MT149}	Port 5 Cable Fault.	Possible electrical short in the coax cable, or RAU problem.
{MT150}	Port 6 Cable Fault.	Possible electrical short in the coax cable, or RAU problem.
{MT151}	Port 7 Cable Fault.	Possible electrical short in the coax cable, or RAU problem.
{MT152}	Port 8 Cable Fault.	Possible electrical short in the coax cable, or RAU problem.
{MT153}	Port 1 Trip.	Remote Unit is drawing too much current.
{MT154}	Port 2 Trip.	Remote Unit is drawing too much current.
{MT155}	Port 3 Trip.	Remote Unit is drawing too much current.
{MT156}	Port 4 Trip.	Remote Unit is drawing too much current.
{MT157}	Port 5 Trip.	Remote Unit is drawing too much current.
{MT158}	Port 6 Trip.	Remote Unit is drawing too much current.
{MT159}	Port 7 Trip.	Remote Unit is drawing too much current.
{MT160}	Port 8 Trip.	Remote Unit is drawing too much current.
{MF161}	Problem detected in the Hub.	Contact ADC Support for more information.
{MF162}	Problem detected in the Hub.	Contact ADC Support for more information.
{MF163}	Problem detected in the Hub.	Contact ADC Support for more information.
{MF164}	Problem detected in the Hub.	Contact ADC Support for more information.
{MF165}	Problem detected in the Hub.	Contact ADC Support for more information.
{MF166}	Problem detected in the Hub.	Contact ADC Support for more information.
{MF167}	Problem detected in the Hub.	Contact ADC Support for more information.
{MF168}	Problem detected in the Hub.	Contact ADC Support for more information.
{MF169}	Problem detected in the Hub.	Contact ADC Support for more information.
{MF170}	Problem detected in the Hub.	Contact ADC Support for more information.
{MF171}	Problem detected in the Hub.	Contact ADC Support for more information.
{MF172}	Problem detected in the Hub.	Contact ADC Support for more information.
{MF173}	Problem detected in the Hub.	Contact ADC Support for more information.
{MF174}	Problem detected in the Hub.	Contact ADC Support for more information.
{MF175}	Problem detected in the Hub.	Contact ADC Support for more information.
{MF176}	Problem detected in the Hub.	Contact ADC Support for more information.

## C.2 Faults Reported for System CPU

**Table C-2** Faults for System CPU

Message Number	Description	Reason/Action
{SF01}	No internal communications.	No internal communications in preceding 2 minutes. Power cycle to clear.
{SF02}	Unable to open file (sysinfo).	System CPU rebooted.
{SF03}	Unable to open file (sysstat).	System CPU rebooted.
{SF04}	Invalid internal response.	System CPU rebooted, internal command does not return valid response after 4 retries.
{SF05}	No MAC address.	System CPU rebooted, unable to read MAC address from the Ethernet driver.
{SF06}	Unable to open file (sysinfo_org).	System CPU rebooted.
{SF07}	Unable to open file (sbc_status).	System CPU rebooted.
{SF08}	Invalid internal field response.	System CPU rebooted, internal command format invalid.
{SF09}	Unable to open file (fileTTL).	System CPU rebooted.
{SF10}	Invalid internal ASCII response.	System CPU rebooted, illegal number of bytes.
{SF11}	Unable to open file (sysalarm).	System CPU rebooted.
{SF12}	Unable to open file (password_etb).	System CPU rebooted.
{SF13}	Unable to open file (CRC).	System CPU rebooted.
{SF14}	Problem detected in the System CPU.	Contact ADC Support for more information.
{SF15}	pThread not executing.	System CPU rebooted.
{SF16}	Problem detected in the System CPU.	Contact ADC Support for more information.
{SF17}	Problem detected in the System CPU.	Contact ADC Support for more information.
{SF18}	Problem detected in the System CPU.	Contact ADC Support for more information.
{SF19}	Problem detected in the System CPU.	Contact ADC Support for more information.
{SF20}	Problem detected in the System CPU.	Contact ADC Support for more information.
{SF21}	Problem detected in the System CPU.	Contact ADC Support for more information.
{SF22}	Problem detected in the System CPU.	Contact ADC Support for more information.
{SF23}	Problem detected in the System CPU.	Contact ADC Support for more information.
{SF24}	Problem detected in the System CPU.	Contact ADC Support for more information.
{SF25}	Problem detected in the System CPU.	Contact ADC Support for more information.
{SF26}	Problem detected in the System CPU.	Contact ADC Support for more information.
{SF27}	Problem detected in the System CPU.	Contact ADC Support for more information.
{SF28}	Problem detected in the System CPU.	Contact ADC Support for more information.
{SF29}	Problem detected in the System CPU.	Contact ADC Support for more information.
{SF30}	Problem detected in the System CPU.	Contact ADC Support for more information.
{SF31}	Problem detected in the System CPU.	Contact ADC Support for more information.
{SF32}	Problem detected in the System CPU.	Contact ADC Support for more information.

## C.3 Faults for Expansion Hubs

**Table C-3 Fault Messages for Expansion Hubs**

Message Number	Description	Reason/Action
{EF01}	Software error occurred and recovered.	If this happens repeatedly, replace the Hub.
{EF02}	Software reset occurred and recovered, or firmware download.	If this happens repeatedly, replace the Hub.
{EF03}	Software reset occurred and recovered.	If this happens repeatedly, replace the Hub.
{EF04}	Software reset occurred and recovered.	If this happens repeatedly, replace the Hub.
{EF05}	Software error occurred and recovered.	If this happens repeatedly, replace the Hub.
{EF06}	Firmware download.	Firmware download.
{EF07}	Hub power cycle.	Hub power cycle.
{EF08}	MH communications failure.	No communications from MH in THE preceding 90 seconds.
{EF09}	MH communications failure.	EH uplink messages not getting to the MH.
{EF10}	Hardware failure (PLL).	Cycle power once. If the fault persists, replace the Hub.
{EF11}	Hardware failure (54 VDC).	54 VDC power supply is out of range, replace the Hub.
{EF12}	Problem detected in the EH.	Contact ADC Support for more information.
{EF13}	Band not programmed.	Cycle power once. If the fault persists, replace the Hub.
{EF14}	Low optical input power.	Check downlink fiber connections.
{EF15}	Hardware failure (Optical Output Power).	Cycle power once. If the fault persists, replace the Hub.
{EF16}	Self Lockout (All Bands).	The Hub has shutdown the system due to an internal fault. The system is offline.
{EF17}	Commanded Out-of-service (Band 1).	Band 1 commanded out-of-service by the user.
{EF18}	Fault lockout (Band 1).	Band 1 out-of-service due to an MH fault.
{EF19}	Problem detected in the EH.	Contact ADC Support for more information.
{EF20}	Problem detected in the EH.	Contact ADC Support for more information.
{EF21}	Problem detected in the EH.	Contact ADC Support for more information.
{EF22}	Problem detected in the EH.	Contact ADC Support for more information.
{EF23}	Problem detected in the EH.	Contact ADC Support for more information.
{EF24}	Problem detected in the EH.	Contact ADC Support for more information.
{EF25}	Commanded Out-of-service (Band 2).	Band 2 commanded out-of-service by the user.



**Table C-3 Fault Messages for Expansion Hubs (continued)**

<b>Message Number</b>	<b>Description</b>	<b>Reason/Action</b>
{EF26}	Fault lockout (Band 2).	Band 2 out-of-service due to MH fault.
{EF27}	Problem detected in the EH.	Contact ADC Support for more information.
{EF28}	Problem detected in the EH.	Contact ADC Support for more information.
{EF29}	Problem detected in the EH.	Contact ADC Support for more information.
{EF30}	Problem detected in the EH.	Contact ADC Support for more information.
{EF31}	Problem detected in the EH.	Contact ADC Support for more information.
{EF32}	Problem detected in the EH.	Contact ADC Support for more information.
{EF33}	Commanded Out-of-service (Band 3).	Band 3 commanded out-of-service by the user.
{EF34}	Fault lockout (Band 3).	Band 3 out-of-service due to an MH fault.
{EF35}	Problem detected in the EH.	Contact ADC Support for more information.
{EF36}	Problem detected in the EH.	Contact ADC Support for more information.
{EF37}	Problem detected in the EH.	Contact ADC Support for more information.
{EF38}	Problem detected in the EH.	Contact ADC Support for more information.
{EF39}	Problem detected in the EH.	Contact ADC Support for more information.
{EF40}	Problem detected in the EH.	Contact ADC Support for more information.
{ED129}	Port 1 Disconnected.	Unit is disconnected.
{ED130}	Port 2 Disconnected.	Unit is disconnected.
{ED131}	Port 3 Disconnected.	Unit is disconnected.
{ED132}	Port 4 Disconnected.	Unit is disconnected.
{ED133}	Port 5 Disconnected.	Unit is disconnected.
{ED134}	Port 6 Disconnected.	Unit is disconnected.
{ED135}	Port 7 Disconnected.	Unit is disconnected.
{ED136}	Port 8 Disconnected.	Unit is disconnected.
{EC137}	Port 1 No Communications.	No communications with remote unit.
{EC138}	Port 2 No Communications.	No communications with remote unit.
{EC139}	Port 3 No Communications.	No communications with remote unit.
{EC140}	Port 4 No Communications.	No communications with remote unit.
{EC141}	Port 5 No Communications.	No communications with remote unit.
{EC142}	Port 6 No Communications.	No communications with remote unit.

---

---

**Table C-3 Fault Messages for Expansion Hubs (continued)**

<b>Message Number</b>	<b>Description</b>	<b>Reason/Action</b>
{EC143}	Port 7 No Communications.	No communications with remote unit.
{EC144}	Port 8 No Communications.	No communications with remote unit.
{ET145}	Port 1 Cable Fault.	Possible electrical short in the coaxial cable, or an RAU problem.
{ET146}	Port 2 Cable Fault.	Possible electrical short in the coaxial cable, or an RAU problem.
{ET147}	Port 3 Cable Fault.	Possible electrical short in the coaxial cable, or an RAU problem.
{ET148}	Port 4 Cable Fault.	Possible electrical short in the coaxial cable, or an RAU problem.
{ET149}	Port 5 Cable Fault.	Possible electrical short in the coaxial cable, or an RAU problem.
{ET150}	Port 6 Cable Fault.	Possible electrical short in the coaxial cable, or an RAU problem.
{ET151}	Port 7 Cable Fault.	Possible electrical short in the coaxial cable, or an RAU problem.
{ET152}	Port 8 Cable Fault.	Possible electrical short in the coaxial cable, or an RAU problem.
{ET153}	Port 1 Trip.	The Remote Unit is drawing too much current.
{ET154}	Port 2 Trip.	The Remote Unit is drawing too much current.
{ET155}	Port 3 Trip.	The Remote Unit is drawing too much current.
{ET156}	Port 4 Trip.	The Remote Unit is drawing too much current.
{ET157}	Port 5 Trip.	The Remote Unit is drawing too much current.
{ET158}	Port 6 Trip.	The Remote Unit is drawing too much current.
{ET159}	Port 7 Trip.	The Remote Unit is drawing too much current.
{ET160}	Port 8 Trip.	The Remote Unit is drawing too much current.

## C.4 Faults for RAUs

**Table C-4 Faults for RAUs**

Message Number	Description	Reason/Action
{RF01}	Software error occurred and recovered.	If this happens repeatedly, replace the RAU.
{RF02}	Software error occurred and recovered.	If this happens repeatedly, replace the RAU.
{RF03}	Software error occurred and recovered.	If this happens repeatedly, replace the RAU.
{RF04}	Software reset occurred and recovered, or firmware download.	If this happens repeatedly, replace the RAU.
{RF05}	Software error occurred and recovered.	If this happens repeatedly, replace the RAU.
{RF06}	Problem detected in the RAU.	Contact ADC Support for more information.
{RF07}	RAU power cycle.	RAU power cycle.
{RF08}	Problem detected in the RAU.	Contact ADC Support for more information.
{RF09}	Invalid band.	The RAU doesn't support programmed band. Check the RAU type against the band programmed in the hub.
{RF10}	Low input DC voltage.	Check the coaxial cable for high RF loss. Try another Hub port. If the fault persists, replace the RAU. If the fault clears, mark the Hub port as unusable and replace the Hub when possible.
{RF11}	Hardware Failure (DL PLL Band 1).	Cycle power once. If the fault persists, replace the RAU.
{RF12}	Hardware Failure (DL PLL Band 2).	Cycle power once. If the fault persists, replace the RAU.
{RF13}	Hardware Failure (DL PLL Band 3).	Cycle power once. If the fault persists, replace the RAU.
{RF14}	Hardware Failure (UL PLL Band 1).	Cycle power once. If the fault persists, replace the RAU.
{RF15}	Hardware Failure (UL PLL Band 2).	Cycle power once. If the fault persists, replace the RAU.
{RF16}	Hardware Failure (UL PLL Band 3).	Cycle power once. If the fault persists, replace the RAU.
{RF17}	Hardware Failure (PA Band 1).	Cycle power once. If the fault persists, replace the RAU.
{RF18}	Hardware Failure (PA Band 2).	Cycle power once. If the fault persists, replace the RAU.
{RF19}	Hardware Failure (PA Band 3).	Cycle power once. If the fault persists, replace the RAU.
{RF20}	Hardware Failure (UL Pilot).	Cycle power once. If the fault persists, replace the RAU.
{RL21}	Commanded Out-of-service (Band 1).	Band 1 commanded out-of-service by User. Command In-Service on Band 1 to restore service.
{RL22}	Commanded Out-of-service (Band 2).	Band 2 commanded out-of-service by User. Command In-Service on Band 2 to restore service.
{RL23}	Commanded Out-of-service (Band 3).	Band 3 commanded out-of-service by User. Command In-Service on Band 3 to restore service.
{RF24}	Problem detected in the RAU.	Contact ADC Support for more information.
{RX25}	Commanded shutdown (Band 1).	Check the status of hub to which the RAU is connected.
{RX26}	Commanded shutdown (Band 2).	Check the status of hub to which the RAU is connected.
{RX27}	Commanded shutdown (Band 3).	Check the status of the hub to which the RAU is connected.
{RF28}	Internal shutdown (Band 1).	RAU Fault condition in band 1 path (or common path).
{RF29}	Internal shutdown (Band 2).	RAU Fault condition in band 2 path (or common path).
{RF30}	Internal shutdown (Band 3).	RAU Fault condition in band 3 path (or common path).
{RF31}	Hardware Failure (UL PLL2 Band 1).	Cycle power once. If the fault persists, replace the RAU.
{RF32}	Problem detected in the RAU.	Contact ADC Support for more information.

---

## C.5 Messages for Main Hubs

### Warning Messages

Warnings alert you to conditions that indicate possible service impact. Warnings are displayed in the Messages pane in red lettering.

Before addressing warnings, ensure that all faults are resolved. Take appropriate action to resolve the warnings, as indicated in the following tables.

---

**NOTE:** AdminBrowser v000007 or higher displays events (faults, warnings, or status messages) depending on your view preference. To change your view preference, refer to Section 3.5, “Faults, Warnings, and Status Messages” of the Fusion Installation, Operation, and Maintenance Manual.

---

### Status Messages

Status messages alert you to conditions that are important, but generally do not impact service. Status messages alert you to conditions that are important, but generally do not impact service. Status messages are displayed in the Messages pane in blue lettering.

---

**NOTE:** AdminBrowser v000007 or higher displays events (faults, warnings, or status messages) depending on your view preference. To change your view preference, refer to Section 3.5, “Faults, Warnings, and Status Messages” of the Fusion Installation, Operation, and Maintenance Manual.

---

---

**NOTE:** The icons displayed in the system status tree assume that there are no other faults, warnings, or status present.

---

In Table C-5, the message number is in the following form:

[Mnn]/X where nn equals the message number, and X equals the default of either Status (S) or Warning (W).

**Table C-5 Warnings/Status Messages for Main Hubs**

<b>Message Number/Default</b>	<b>Description</b>	<b>Reason/Action</b>
[M01]/S	Fan 1 failure.	Check the fan for rotation, air flow blockage, and dust. Replace the Hub on high temperature warning.
[M02]/S	Fan 2 failure.	Check the fan for rotation, air flow blockage, and dust. Replace the Hub on high temperature warning.
[M03]/S	54 VDC Pwr Supply Fan failure.	Check the fan for rotation, air flow blockage, and dust. Replace the Hub on high temperature warning.
[M04]/W	5 VDC Monitor.	DC power out of range, replace the Hub.
[M05]/W	9 VDC Monitor.	DC power out of range, replace the Hub.
[M06]/W	54 VDC Monitor.	DC power out of range, replace the Hub.
[M07]/W	3 VDC Monitor.	DC power out of range, replace the Hub.
[M08]/W	12 VDC Monitor.	DC power out of range, replace the Hub.
[M09]/W	Temperature High.	Reduce ambient temperature, check for air flow blockage, fan rotation.
[M10]/W	-5 VDC Monitor.	DC power is out of range, replace the Hub.
[M11]/W	High laser current.	Output laser failure possible, replace the Hub when possible.
[M12]/W	DL path loss is too high	Replace the Hub.
[M13]/S	Low input optical (Port 1).	Check the uplink fiber.
[M14]/S	Low input optical (Port 2).	Check the uplink fiber.
[M15]/S	Low input optical (Port 3).	Check the uplink fiber.
[M16]/S	Low input optical (Port 4).	Check the uplink fiber.
[M17]/S	Hardware failure (Test Tone PLL Band 1).	Unable to perform DL system test.
[M18]/S	Hardware failure (Test Tone Too High Band 1).	Unable to perform DL system test.
[M19]/S	Hardware failure (Test Tone Too Low Band 1).	Unable to perform DL system test.
[M20]/W	Overdrive limiter active (Band 1).	Reduce input signal power to avoid potential component damage.
[M21]/W	CEMark limiter at maximum (Band 1).	Reduce input signal power to avoid drop in system gain.
[M22]/W	No DL test tone (Band 1).	Hub DL gain is low.
[M23]/S	No UL test tone (Band 1).	Hub UL path gain is low.
[M24]/S	Problem detected in the system.	Contact ADC Support for more information.
[M25]/S	Hardware failure (Test Tone PLL Band 2).	Unable to perform DL system test. Replace the hub when possible.
[M26]/S	Hardware failure (Test Tone Too High Band 2).	Unable to perform DL system test. Replace the hub when possible.
[M27]/S	Hardware failure (Test Tone Too Low Band 2).	Unable to perform DL system test. Replace the hub when possible.
[M28]/W	Overdrive limiter active (Band 2).	Reduce input signal power to avoid potential component damage.
[M29]/W	CEMark limiter at maximum (Band 2).	Reduce input signal power to avoid drop in system gain.

**Table C-5 Warnings/Status Messages for Main Hubs (continued)**

<b>Message Number/Default</b>	<b>Description</b>	<b>Reason/Action</b>
[M30]/W	No DL test tone (Band 2).	Hub DL path gain is low.
[M31]/S	No UL test tone (Band 2).	Hub UL path gain is low.
[M32]/S	Problem detected in the system.	Contact ADC Support for more information.
[M33]/S	Hardware failure (Test Tone PLL Band 3).	Unable to perform DL system test.
[M34]/S	Hardware failure (Test Tone Too High Band 3).	Unable to perform DL system test.
[M35]/S	Hardware failure (Test Tone Too Low Band 3).	Unable to perform DL system test.
[M36]/W	Overdrive limiter active (Band 3).	Reduce input signal power to avoid potential component damage.
[M37]/W	CEMark limiter at maximum (Band 3).	Reduce input signal power to avoid drop in system gain.
[M38]/W	No DL test tone (Band 3).	Hub DL path gain is low.
[M39]/S	No UL test tone (Band 3).	Hub UL path gain is low.
[M40]/S	Problem detected in the Hub.	Contact ADC Support for more information.
[M41]/W	Port 1 No DL test tone (Band 1).	Hub/Port DL path gain is low.
[M42]/W	Port 2 No DL test tone (Band 1).	Hub/Port DL path gain is low.
[M43]/W	Port 3 No DL test tone (Band 1).	Hub/Port DL path gain is low.
[M44]/W	Port 4 No DL test tone (Band 1).	Hub/Port DL path gain is low.
[M45]/W	Port 5 No DL test tone (Band 1).	Hub/Port DL path gain is low.
[M46]/W	Port 6 No DL test tone (Band 1).	Hub/Port DL path gain is low.
[M47]/W	Port 7 No DL test tone (Band 1).	Hub/Port DL path gain is low.
[M48]/W	Port 8 No DL test tone (Band 1).	Hub/Port DL path gain is low.
[M49]/W	Port 1 No DL test tone (Band 2).	Hub/Port DL path gain is low.
[M50]/W	Port 2 No DL test tone (Band 2).	Hub/Port DL path gain is low.
[M51]/W	Port 3 No DL test tone (Band 2).	Hub/Port DL path gain is low.
[M52]/W	Port 4 No DL test tone (Band 2).	Hub/Port DL path gain is low.
[M53]/W	Port 5 No DL test tone (Band 2).	Hub/Port DL path gain is low.
[M54]/W	Port 6 No DL test tone (Band 2).	Hub/Port DL path gain is low.
[M55]/W	Port 7 No DL test tone (Band 2).	Hub/Port DL path gain is low.
[M56]/W	Port 8 No DL test tone (Band 2).	Hub/Port DL path gain is low.
[M57]/W	Port 1 No DL test tone (Band 3).	Hub/Port DL path gain is low.
[M58]/W	Port 2 No DL test tone (Band 3).	Hub/Port DL path gain is low.
[M59]/W	Port 3 No DL test tone (Band 3).	Hub/Port DL path gain is low.
[M60]/W	Port 4 No DL test tone (Band 3).	Hub/Port DL path gain is low.
[M61]/W	Port 5 No DL test tone (Band 3).	Hub/Port DL path gain is low.
[M62]/W	Port 6 No DL test tone (Band 3).	Hub/Port DL path gain is low.
[M63]/W	Port 7 No DL test tone (Band 3).	Hub/Port DL path gain is low.
[M64]/W	Port 8 No DL test tone (Band 3).	Hub/Port DL path gain is low.
[M65]/S	No UL test tone (Band 1).	Hub/Port UL path gain is low.

**Table C-5 Warnings/Status Messages for Main Hubs (continued)**

<b>Message Number/Default</b>	<b>Description</b>	<b>Reason/Action</b>
[M66]/S	Problem detected in the Hub.	Contact ADC Support for more information.
[M67]/S	Problem detected in the Hub.	Contact ADC Support for more information.
[M68]/S	No UL test tone (Port 4/Band 1).	Hub/Port UL path gain is low.
[M69]/S	No UL test tone (Band 2).	Hub/Port UL path gain is low.
[M70]/S	No UL test tone (Port 2/Band 2).	Hub/Port UL path gain is low.
[M71]/S	No UL test tone (Port 3/Band 2).	Hub/Port UL path gain is low.
[M72]/S	No UL test tone (Port 4/Band 2).	Hub/Port UL path gain is low.
[M73]/S	No UL test tone (Band 3).	Hub/Port UL path gain is low.
[M74]/S	No UL test tone (Port 2/Band 3).	Hub/Port UL path gain is low.
[M75]/S	No UL test tone (Port 3/Band 3).	Hub/Port UL path gain is low.
[M76]/S	No UL test tone (Port 4/Band 3).	Hub/Port UL path gain is low.
[M77]/S	Problem detected in the Hub.	Contact ADC Support for more information.
[M78]/S	Problem detected in the Hub.	Contact ADC Support for more information.
[M79]/S	Problem detected in the Hub.	Contact ADC Support for more information.
[M80]/S	Problem detected in the Hub.	Contact ADC Support for more information.
[M81]/W	Port 1 DL path loss is high.	If the problem is on more than one port, replace the Hub. Switch the cable connection to a different hub port until the Hub can be replaced.
[M82]/W	Port 2 DL path loss is high.	If the problem is on more than one port, replace the Hub. Switch the cable connection to a different hub port until the Hub can be replaced.
[M83]/W	Port 3 DL path loss is high.	If the problem is on more than one port, replace the Hub. Switch the cable connection to a different hub port until the Hub can be replaced.
[M84]/W	Port 4 DL path loss is high.	If the problem is on more than one port, replace the Hub. Switch the cable connection to a different hub port until the Hub can be replaced.
[M85]/W	Port 5 DL path loss is high.	If the problem is on more than one port, replace the Hub. Switch the cable connection to a different hub port until the Hub can be replaced.
[M86]/W	Port 6 DL path loss is high.	If the problem is on more than one port, replace the Hub. Switch the cable connection to a different hub port until the Hub can be replaced.
[M87]/W	Port 7 DL path loss is high.	If the problem is on more than one port, replace the Hub. Switch the cable connection to a different hub port until the Hub can be replaced.
[M88]/W	Port 8 DL path loss is high.	If the problem is on more than one port, replace the Hub. Switch the cable connection to a different hub port until the Hub can be replaced.
[M89]/W	Port 1 UL path loss is high.	Check the cable for high RF loss. Switch the cable connection to a different hub port. If the problem is on more than one port, replace the Hub, otherwise replace the RAU.
[M90]/W	Port 2 UL path loss is high.	Check the cable for high RF loss. Switch the cable connection to a different hub port. If the problem is on more than one port, replace the Hub, otherwise replace the RAU.
[M91]/W	Port 3 UL path loss is high.	Check the cable for high RF loss. Switch the cable connection to a different hub port. If the problem is on more than one port, replace the Hub, otherwise replace the RAU.

**Table C-5 Warnings/Status Messages for Main Hubs (continued)**

<b>Message Number/Default</b>	<b>Description</b>	<b>Reason/Action</b>
[M92]/W	Port 4 UL path loss is high.	Check the cable for high RF loss. Switch the cable connection to a different hub port. If the problem is on more than one port, replace the Hub, otherwise replace the RAU.
[M93]/W	Port 5 UL path loss is high.	Check the cable for high RF loss. Switch the cable connection to a different hub port. If the problem is on more than one port, replace the Hub, otherwise replace the RAU.
[M94]/W	Port 6 UL path loss is high.	Check the cable for high RF loss. Switch the cable connection to a different hub port. If the problem is on more than one port, replace the Hub, otherwise replace the RAU.
[M95]/W	Port 7 UL path loss is high.	Check the cable for high RF loss. Switch the cable connection to a different hub port. If the problem is on more than one port, replace the Hub, otherwise replace the RAU.
[M96]/W	Port 8 UL path loss is high.	Check the cable for high RF loss. Switch the cable connection to a different hub port. If the problem is on more than one port, replace the Hub, otherwise replace the RAU.
[M97]/W	Port 1 UL path exceeds maximum gain.	If the problem is common to more than one port, replace the Hub, otherwise check the RAU.
[M98]/W	Port 2 UL path exceeds maximum gain.	If the problem is common to more than one port, replace the Hub, otherwise check the RAU.
[M99]/W	Port 2 UL path exceeds maximum gain.	If the problem is common to more than one port, replace the Hub, otherwise check the RAU.
[M100]/W	Port 2 UL path exceeds maximum gain.	If the problem is common to more than one port, replace the Hub, otherwise check the RAU.
[M101]/W	Port 2 UL path exceeds maximum gain.	If the problem is common to more than one port, replace the Hub, otherwise check the RAU.
[M102]/W	Port 2 UL path exceeds maximum gain.	If the problem is common to more than one port, replace the Hub, otherwise check the RAU.
[M103]/W	Port 2 UL path exceeds maximum gain.	If the problem is common to more than one port, replace the Hub, otherwise check the RAU.
[M104]/W	Port 8 UL path exceeds maximum gain.	If the problem is common to more than one port, replace the Hub, otherwise check the RAU.
[M105]/W	Port 1 54 VDC Power Enabled.	Caution: Port 54 VDC power may be present at the output.
[M106]/W	Port 2 54 VDC Power Enabled.	Caution: Port 54 VDC power may be present at the output.
[M107]/W	Port 3 54 VDC Power Enabled.	Caution: Port 54 VDC power may be present at the output.
[M108]/W	Port 4 54 VDC Power Enabled.	Caution: Port 54 VDC power may be present at the output.
[M109]/W	Port 5 54 VDC Power Enabled.	Caution: Port 54 VDC power may be present at the output.
[M110]/W	Port 6 54 VDC Power Enabled.	Caution: Port 54 VDC power may be present at the output.
[M111]/W	Port 7 54 VDC Power Enabled.	Caution: Port 54 VDC power may be present at the output.
[M112]/W	Port 8 54 VDC Power Enabled.	Caution: Port 54 VDC power may be present at the output.
[M113]/S	Port 1 UL Pilot Invalid Enable.	Check all downstream units for uplink pilot control.
[M114]/S	Port 2 UL Pilot Invalid Enable.	Check all downstream units for uplink pilot control.
[M115]/S	Port 3 UL Pilot Invalid Enable.	Check all downstream units for uplink pilot control.
[M116]/S	Port 4 UL Pilot Invalid Enable.	Check all downstream units for uplink pilot control.
[M117]/S	Port 5 UL Pilot Invalid Enable.	Check all downstream units for uplink pilot control.
[M118]/S	Port 6 UL Pilot Invalid Enable.	Check all downstream units for uplink pilot control.
[M119]/S	Port 7 UL Pilot Invalid Enable.	Check all downstream units for uplink pilot control.



**Table C-5 Warnings/Status Messages for Main Hubs (continued)**

<b>Message Number/Default</b>	<b>Description</b>	<b>Reason/Action</b>
[M120]/S	Port 8 UL Pilot Invalid Enable.	Check all downstream units for uplink pilot control.
[M121]/S	3.3 VDC Monitor.	Possible 3.3 VDC failure.
[M122]/W	TDD signaling tone outside valid range (Band 1).	Replace the Hub.
[M123]/W	TDD signaling tone outside valid range (Band 2).	Replace the Hub.

## C.6 Messages for System CPUs

In Table C-6, the message number is in the following form:

[Snn]/X where nn equals the message number, and X equals the default of either Status (S) or Warning (W).

**Table C-6 Warning/Status Messages for System CPUs**

<b>Message Number/Default</b>	<b>Description</b>	<b>Reason/Action</b>
[S01]/W	Alarm Input 1.	Check equipment connected to alarm input 1.
[S02]/W	Alarm Input 2.	Check equipment connected to alarm input 2.
[S03]/W	Alarm Input 3.	Check equipment connected to alarm input 3.
[S04]/S	Performed System Test	System has just performed system test.
[S05]/S	Problem detected in the System CPU.	Contact ADC Support for more information.
[S06]/S	Loaded default etb file.	Contact ADC Support for more information.
[S07]/S	Loaded default SBC status file.	Contact ADC Support for more information.
[S08]/S	Problem detected in the System CPU.	Contact ADC Support for more information.
[S09]/S	TTL is full.	Retrieve the TTL and erase.
[S10]/S	Problem detected in the System CPU.	Contact ADC Support for more information.
[S11]/S	Problem detected in the System CPU.	Contact ADC Support for more information.
[S12]/S	Loaded default Password file.	Contact ADC Support for more information.
[S13]/S	Loaded default sys config file.	Contact ADC Support for more information.
[S14]/S	Communication retries exceeded.	Attempted command three times without response.
[S15]/S	Problem detected in the System CPU.	Contact ADC Support for more information.
[S16]/S	Problem detected in the System CPU.	Contact ADC Support for more information.

## C.7 Messages for Expansion Hubs

**Table C-7 Warning/Status Message for Expansion Hubs**

<b>Message Number /Default</b>	<b>Description</b>	<b>Reason/Action</b>
[E01]/W	Alarm Input 1.	Check the equipment connected to alarm input 1.
[E02]/W	Alarm Input 2.	Check the equipment connected to alarm input 2.
[E03]/W	Alarm Input 3.	Check the equipment connected to alarm input 3.
[E04]/S	Problem detected in the EH.	Contact ADC Support for more information.
[E05]/W	SNMP Trap #1.	TBD.
[E06]/W	SNMP Trap #2.	TBD.
[E07]/W	SNMP Trap #3.	TBD.
[E08]/S	Problem detected in the EH.	Contact ADC Support for more information.
[E09]/S	Fan 1 failure.	Check the fan for proper rotation, air flow blockage, and dust accumulation. Replace the Hub on high temperature warning.
[E10]/S	Fan 2 failure.	Check the fan for proper rotation, air flow blockage, and dust accumulation. Replace the Hub on high temperature warning.
[E11]/W	-5 VDC Monitor.	DC power out of range, replace the Hub.
[E12]/W	5 VDC Monitor.	DC power out of range, replace the Hub.
[E13]/W	9 VDC Monitor.	DC power out of range, replace the Hub.
[E14]/W	54 VDC Pwr Supply failure.	DC port power supply out of range, replace the Hub.
[E15]/W	3 VDC Monitor.	DC power out of range, replace the Hub.
[E16]/W	12 VDC Monitor.	DC power out of range, replace the Hub.
[E17]/W	Temperature High.	Reduce the ambient temperature, check for air flow blockage, fan rotation.
[E18]/W	DL path exceeds maximum gain.	If the problem is common to more than one port, replace the MH, otherwise check the EH.
[E19]/W	DL path loss is high.	Check the cable for high RF loss. Switch the cable connection to a different MH port. If the problem is on more than one port, replace the EH, otherwise replace the RAU.
[E20]/W	Hardware Failure (High UL Pilot).	Cycle power once. If the fault persists, replace the EH.
[E21]/W	Hardware Failure (Low UL Pilot).	Cycle power once. If the fault persists, replace the EH.
[E22]/W	Low optical input power.	Check the downlink fiber connection.
[E23]/W	High laser current.	Contact ADC Support for more information.
[E24]/S	Problem detected in the EH.	Contact ADC Support for more information.
[E25]/W	Port 1 No DL test tone (Band 1).	Hub/Port DL path gain is low.
[E26]/W	Port 2 No DL test tone (Band 1).	Hub/Port DL path gain is low.
[E27]/W	Port 3 No DL test tone (Band 1).	Hub/Port DL path gain is low.
[E28]/W	Port 4 No DL test tone (Band 1).	Hub/Port DL path gain is low.
[E29]/W	Port 5 No DL test tone (Band 1).	Hub/Port DL path gain is low.
[E30]/W	Port 6 No DL test tone (Band 1).	Hub/Port DL path gain is low.
[E31]/W	Port 7 No DL test tone (Band 1).	Hub/Port DL path gain is low.
[E32]/W	Port 8 No DL test tone (Band 1).	Hub/Port DL path gain is low.

**Table C-7 Warning/Status Message for Expansion Hubs (continued)**

<b>Message Number /Default</b>	<b>Description</b>	<b>Reason/Action</b>
[E33]/W	Port 1 No DL test tone (Band 2).	Hub/Port DL path gain is low.
[E34]/W	Port 2 No DL test tone (Band 2).	Hub/Port DL path gain is low.
[E35]/W	Port 3 No DL test tone (Band 2).	Hub/Port DL path gain is low.
[E36]/W	Port 4 No DL test tone (Band 2).	Hub/Port DL path gain is low.
[E37]/W	Port 5 No DL test tone (Band 2).	Hub/Port DL path gain is low.
[E38]/W	Port 6 No DL test tone (Band 2).	Hub/Port DL path gain is low.
[E39]/W	Port 7 No DL test tone (Band 2).	Hub/Port DL path gain is low.
[E40]/W	Port 8 No DL test tone (Band 2).	Hub/Port DL path gain is low.
[E41]/W	Port 1 No DL test tone (Band 3).	Hub/Port DL path gain is low.
[E42]/W	Port 2 No DL test tone (Band 3).	Hub/Port DL path gain is low.
[E43]/W	Port 3 No DL test tone (Band 3).	Hub/Port DL path gain is low.
[E44]/W	Port 4 No DL test tone (Band 3).	Hub/Port DL path gain is low.
[E45]/W	Port 5 No DL test tone (Band 3).	Hub/Port DL path gain is low.
[E46]/W	Port 6 No DL test tone (Band 3).	Hub/Port DL path gain is low.
[E47]/W	Port 7 No DL test tone (Band 3).	Hub/Port DL path gain is low.
[E48]/W	Port 8 No DL test tone (Band 3).	Hub/Port DL path gain is low.
[E49]/W	Port 1 DL path loss is high.	If the problem is on more than one port, replace the Hub. Switch the cable connection to a different hub port until the Hub can be replaced.
[E50]/W	Port 2 DL path loss is high.	If the problem is on more than one port, replace the Hub. Switch the cable connection to a different hub port until the Hub can be replaced.
[E51]/W	Port 3 DL path loss is high.	If the problem is on more than one port, replace the Hub. Switch the cable connection to a different hub port until the Hub can be replaced.
[E52]/W	Port 4 DL path loss is high.	If the problem is on more than one port, replace the Hub. Switch the cable connection to a different hub port until the Hub can be replaced.
[E53]/W	Port 5 DL path loss is high.	If the problem is on more than one port, replace the Hub. Switch the cable connection to a different hub port until the Hub can be replaced.
[E54]/W	Port 6 DL path loss is high.	If the problem is on more than one port, replace the Hub. Switch the cable connection to a different hub port until the Hub can be replaced.
[E55]/W	Port 7 DL path loss is high.	If the problem is on more than one port, replace the Hub. Switch the cable connection to a different hub port until the Hub can be replaced.
[E56]/W	Port 8 DL path loss is high.	If the problem is on more than one port, replace the Hub. Switch the cable connection to a different hub port until the Hub can be replaced.
[E57]/W	Port 1 UL path loss is high.	Check the cable for high RF loss. Switch the cable connection to a different hub port. If the problem is on more than one port, replace the Hub, otherwise replace the RAU.
[E58]/W	Port 2 UL path loss is high.	Check the cable for high RF loss. Switch the cable connection to a different hub port. If the problem is on more than one port, replace the Hub, otherwise replace the RAU.

**Table C-7 Warning/Status Message for Expansion Hubs (continued)**

<b>Message Number /Default</b>	<b>Description</b>	<b>Reason/Action</b>
[E59]/W	Port 3 UL path loss is high.	Check the cable for high RF loss. Switch the cable connection to a different hub port. If the problem is on more than one port, replace the Hub, otherwise replace the RAU.
[E60]/W	Port 4 UL path loss is high.	Check the cable for high RF loss. Switch the cable connection to a different hub port. If the problem is on more than one port, replace the Hub, otherwise replace the RAU.
[E61]/W	Port 5 UL path loss is high.	Check the cable for high RF loss. Switch the cable connection to a different hub port. If the problem is on more than one port, replace the Hub, otherwise replace the RAU.
[E62]/W	Port 6 UL path loss is high.	Check the cable for high RF loss. Switch the cable connection to a different hub port. If the problem is on more than one port, replace the Hub, otherwise replace the RAU.
[E63]/W	Port 7 UL path loss is high.	Check the cable for high RF loss. Switch the cable connection to a different hub port. If the problem is on more than one port, replace the Hub, otherwise replace the RAU.
[E64]/W	Port 8 UL path loss is high.	Check the cable for high RF loss. Switch the cable connection to a different hub port. If the problem is on more than one port, replace the Hub, otherwise replace the RAU.
[E65]/W	Port 1 UL path exceeds maximum gain.	If the problem is common to more than one port, replace the Hub, otherwise check RAU.
[E66]/W	Port 2 UL path exceeds maximum gain.	If the problem is common to more than one port, replace the Hub, otherwise check RAU.
[E67]/W	Port 3 UL path exceeds maximum gain.	If the problem is common to more than one port, replace the Hub, otherwise check RAU.
[E68]/W	Port 4 UL path exceeds maximum gain.	If the problem is common to more than one port, replace the Hub, otherwise check RAU.
[E69]/W	Port 5 UL path exceeds maximum gain.	If the problem is common to more than one port, replace the Hub, otherwise check RAU.
[E70]/W	Port 6 UL path exceeds maximum gain.	If the problem is common to more than one port, replace the Hub, otherwise check RAU.
[E71]/W	Port 7 UL path exceeds maximum gain.	If problem is common to more than one port, replace the Hub, otherwise check RAU.
[E72]/W	Port 8 UL path exceeds maximum gain.	If the problem is common to more than one port, replace the Hub, otherwise check RAU.
[E73]/W	Port 1 54 VDC Power Enabled.	Caution: Port 54 VDC power may be present at the output.
[E74]/W	Port 2 54 VDC Power Enabled.	Caution: Port 54 VDC power may be present at the output.
[E75]/W	Port 3 54 VDC Power Enabled.	Caution: Port 54 VDC power may be present at the output.
[E76]/W	Port 4 54 VDC Power Enabled.	Caution: Port 54 VDC power may be present at the output.
[E77]/W	Port 5 54 VDC Power Enabled.	Caution: Port 54 VDC power may be present at the output.
[E78]/W	Port 6 54 VDC Power Enabled.	Caution: Port 54 VDC power may be present at the output.
[E79]/W	Port 7 54 VDC Power Enabled.	Caution: Port 54 VDC power may be present at the output.
[E80]/W	Port 8 54 VDC Power Enabled.	Caution: Port 54 VDC power may be present at the output.

## C.8 Messages for RAUs

In Table C-8, the message number is in the following form:

[Rnn]/X where nn equals the message number, and X equals the default of either Status (S) or Warning (W).

**Table C-8 Warning/Status Messages for RAUs**

Message Number Default	Description	Reason/Action
[R01]/W	Temperature High.	Check RAU location for excessive temperature; check for air flow blockage and/or incorrect installation. Move the RAU to a cooler environment.
[R02]/W	No communications from Hub.	Check the cable for high RF loss. Switch the cable connection to a different hub port. If the problem persists, replace the RAU.
[R03]/W	DL RF path loss is too high.	Check the cable for high RF loss. Switch the cable connection to a different hub port. If the problem persists, replace the RAU.
[R04]/W	DL RF path exceeds maximum gain.	Check the Hub for proper operation; switch the cable connection to a different hub port. If the problem persists, replace the RAU.
[R05]/S	DL RF path problem (Band 1).	Unable to complete the DL system end-to-end test, replace the RAU when possible.
[R06]/S	DL RF path problem (Band 2).	Unable to complete the DL system end-to-end test, replace the RAU when possible.
[R07]/S	DL RF path problem (Band 3).	Unable to complete the DL system end-to-end test, replace the RAU when possible.
[R08]/S	System test required.	Run system test.
[R09]/W	Antenna Disconnected.	Check RAU antenna connection; re-run system test.
[R10]/S	UL RF path problem (Band 1).	Unable to complete the UL system end-to-end test, replace the RAU when possible.
[R11]/S	UL RF path problem (Band 2).	Unable to complete the UL system end-to-end test, replace the RAU when possible.
[R12]/S	UL RF path problem (Band 3).	Unable to complete the UL system end-to-end test, replace the RAU when possible.
[R13]/S	Problem detected in the RAU.	Contact ADC Support for more information.
[R14]/S	Problem detected in the RAU.	Contact ADC Support for more information.
[R15]/S	Problem detected in the RAU.	Contact ADC Support for more information.
[R16]/S	Problem detected in the RAU.	Contact ADC Support for more information.
[R17]/S	Antenna disconnected (Band 1).	Check the RAU Band 1 antenna, then rerun the system test.
[R18]/S	Antenna disconnected (Band 2).	Check the RAU Band 2 antenna, then rerun the system test.
[R19]/S	Hardware Failure (UL FD PLL Band 1).	Unable to complete a UL system end-to-end test. Replace the RAU when possible.
[R20]/W	TDD signaling tone outside valid range (Band 1).	If the Main Hub and Expansion Hub are okay, replace the RAU.
[R21]/W	TDD signaling tone outside valid range (Band 2).	If the Main Hub and Expansion Hub are okay, replace the RAU.

---

---

**Table C-8 Warning/Status Messages for RAUs (continued)**

<b>Message Number Default</b>	<b>Description</b>	<b>Reason/Action</b>
[R22]/S	High PA current (Band 1).	The unit is operating with reduced gain. Verify that the input signal is at the appropriate level. If the problem persists, replace the RAU when possible.
[R23]/S	High PA current (Band 2).	The unit is operating with reduced gain. Verify that the input signal is at the appropriate level. If the problem persists, replace the RAU when possible.