

FCC Test Report

Report No.: FC190523E03

FCC ID: NOIKBN873

Test Model: N873

Received Date: May 27, 2019

Test Date: June 13, 2019

Issued Date: July 24, 2019

Applicant: NETRONIX, INC.

Address: No. 945, Boai St., Jubei City, Hsin-Chu,302,Taiwan, R.O.C.

Issued By: Bureau Veritas Consumer Products Services (H.K.) Ltd., Taoyuan Branch
Hsin Chu Laboratory

Lab Address: E-2, No.1, Li Hsin 1st Road, Hsinchu Science Park, Hsinchu City 300,
Taiwan R.O.C.

Test Location (1): E-2, No.1, Li Hsin 1st Road, Hsinchu Science Park, Hsinchu City 300,
Taiwan R.O.C.

Test Location (2): No. 49, Ln. 206, Wende Rd., Shangshan Tsuen, Chiung Lin Hsiang, Hsin
Chu Hsien 307, Taiwan R.O.C.

FCC Registration / 810758 / TW1085 for Test Location (1)
Designation Number: 960022 / TW1058 for Test Location (2)



This report is for your exclusive use. Any copying or replication of this report to or for any other person or entity, or use of our name or trademark, is permitted only with our prior written permission. This report sets forth our findings solely with respect to the test samples identified herein. The results set forth in this report are not indicative or representative of the quality or characteristics of the lot from which a test sample was taken or any similar or identical product unless specifically and expressly noted. Our report includes all of the tests requested by you and the results thereof based upon the information that you provided to us. You have 60 days from date of issuance of this report to notify us of any material error or omission caused by our negligence, provided, however, that such notice shall be in writing and shall specifically address the issue you wish to raise. A failure to raise such issue within the prescribed time shall constitute your unqualified acceptance of the completeness of this report, the tests conducted and the correctness of the report contents. Unless specific mention, the uncertainty of measurement has been explicitly taken into account to declare the compliance or non-compliance to the specification. The report must not be used by the client to claim product certification, approval, or endorsement by TAF or any government agencies.

Table of Contents

Release Control Record	3
1 Certificate of Conformity	4
2 Summary of Test Results.....	5
2.1 Measurement Uncertainty	5
2.2 Modification Record	5
3 General Information	6
3.1 Description of EUT	6
3.2 Features of EUT	6
3.3 Operating Modes of EUT and Determination of Worst Case Operating Mode	7
3.4 Test Program Used and Operation Descriptions.....	7
3.5 Primary Clock Frequencies of Internal Source	7
4 Configuration and Connections with EUT	8
4.1 Connection Diagram of EUT and Peripheral Devices	8
4.2 Configuration of Peripheral Devices and Cable Connections	9
5 Conducted Emissions at Mains Ports.....	10
5.1 Limits	10
5.2 Test Instruments	10
5.3 Test Arrangement	11
5.4 Supplementary Information	11
5.5 Test Results.....	12
6 Radiated Emissions up to 1 GHz	14
6.1 Limits	14
6.2 Test Instruments	15
6.3 Test Arrangement	16
6.4 Supplementary Information	16
6.5 Test Results.....	17
7 Radiated Emissions above 1 GHz.....	19
7.1 Limits	19
7.2 Test Instruments	20
7.3 Test Arrangement	21
7.4 Supplementary Information	21
7.5 Test Results.....	22
8 Pictures of Test Arrangements	24
Appendix – Information of the Testing Laboratories	25

Release Control Record

Issue No.	Description	Date Issued
FC190523E03	Original release.	July 24, 2019

1 Certificate of Conformity

Product: Electronic Display Device

Brand: Rakuten Kobo

Test Model: N873

Sample Status: ENGINEERING SAMPLE

Applicant: NETRONIX, INC.

Test Date: June 13, 2019

Standards: 47 CFR FCC Part 15, Subpart B, Class B
ICES-003:2016 Issue 6, updated Apr. 2019, Class B
ANSI C63.4:2014

The above equipment has been tested by **Bureau Veritas Consumer Products Services (H.K.) Ltd., Taoyuan Branch**, and found compliance with the requirement of the above standards. The test record, data evaluation & Equipment Under Test (EUT) configurations represented herein are true and accurate accounts of the measurements of the sample's EMC characteristics under the conditions specified in this report.

Prepared by : Wendy Wu , **Date:** July 24, 2019
Wendy Wu / Specialist

Approved by : Ken Lu , **Date:** July 24, 2019
Ken Lu / Manager

2 Summary of Test Results

47 CFR FCC Part 15, Subpart B / ICES-003:2016 Issue 6, updated Apr. 2019, Class B

ANSI C63.4:2014

FCC Clause	ICES-003 Clause	Test Item	Result/Remarks	Verdict
15.107	6.1	AC Power Line Conducted Emissions	Minimum passing Class B margin is -18.73 dB at 0.17344 MHz	Pass
15.109	6.2.1	Radiated Emissions up to 1 GHz	Minimum passing Class B margin is -2.18 dB at 270.85 MHz	Pass
	6.2.2	Radiated Emissions above 1 GHz	Minimum passing Class B margin is -9.98 dB at 11469.87 MHz	Pass

Note: Determining compliance based on the results of the compliance measurement, not taking into account measurement instrumentation uncertainty.

2.1 Measurement Uncertainty

Where relevant, the following measurement uncertainty levels have been estimated for tests performed on the EUT:

Measurement	Frequency	Expanded Uncertainty (k=2) (\pm)
Conducted Emissions at mains ports	150kHz ~ 30MHz	1.8 dB
Radiated Emissions up to 1 GHz	30MHz ~ 1GHz	4.0 dB
Radiated Emissions above 1 GHz	1GHz ~ 6GHz	4.7 dB
	6GHz ~ 18GHz	5.2 dB

2.2 Modification Record

There were no modifications required for compliance.

3 General Information

3.1 Description of EUT

Product	Electronic Display Device
Brand	Rakuten Kobo
Test Model	N873
Sample Status	ENGINEERING SAMPLE
Operating Software	NA
Power Supply Rating	3.7Vdc from battery or 5Vdc from USB interface
Accessory Device	NA
Data Cable Supplied	Refer to Note

Note:

1. The EUT may have black and white colors for marketing requirement.
2. The EUT must be supplied with a rechargeable battery as following table:

Brand	Model No.	Spec.
EVE Energy CO., LTD	PR-158098N	Output: 3.7Vdc, 1200mAh, 4.44Wh

3. The antenna provided to the EUT, please refer to the following table:

Brand	Model	Antenna Net Gain (dBi)	Frequency Range (GHz)	Antenna Type	Connector Type
Walsin Technology Corporation	RFECA3216060AAT	2	2.4~2.4835	Ceramic antenna	None

4. The EUT must be supplied with an eMMC as following table

Brand	Model	Size
Sandisk	SDINBDG4-8G	8G Byte

5. The EUT must be supplied with a USB Cable and following different models could be chosen as following table:

No	Brand	Model	Color	Spec.	Difference
1	Yih Fone	SH-0330	White	Shielded, 1.0m	Different color
2	Yih Fone	SH-0152	Black	Shielded, 1.0m	

6. The EUT incorporates a SISO function:

MODULATION MODE	TX & RX CONFIGURATION	
802.11b	1TX	1RX
802.11g	1TX	1RX
802.11n (HT20)	1TX	1RX

7. When USB port is charging the rechargeable battery, the EUT has WiFi function under charging mode. And the USB port is connected to Host unit on transmission mod, the EUT WiFi function will be disabled.

3.2 Features of EUT

The tests reported herein were performed according to the method specified by NETRONIX, INC., for detailed feature description, please refer to the manufacturer's specifications or user's manual.

3.3 Operating Modes of EUT and Determination of Worst Case Operating Mode

For radiated emission test, the EUT has been pre-tested under following test modes, and test mode A was the worst case for final test.

Pre-test Mode	Test Condition		
	Input	Mode	Arrangement
A	DC 5V With Host	USB	Horizontal Placement
B	Battery	WiFi	Horizontal Placement
C	Battery	WiFi	Vertical Placement
D	Battery	WiFi	Side Placement

Note: The test configurations are defined by the applicant requirement.

Test mode is presented in the report as below.

Test Mode	Test Condition		
	Input	Mode	Arrangement
1	DC 5V With Host	USB	Horizontal Placement

3.4 Test Program Used and Operation Descriptions

1. Turn on the power of all equipment.
2. Support unit A (Laptop) runs a test program "EMC.bat" to enable EUT under "R/W mode" continually via one USB cable.
3. Support unit A (Laptop) runs "EMC test.exe" then sends "H" messages to itself.

3.5 Primary Clock Frequencies of Internal Source

The EUT is provided by NETRONIX, INC., for detailed internal source, please refer to the manufacturer's specifications.

4 Configuration and Connections with EUT

4.1 Connection Diagram of EUT and Peripheral Devices

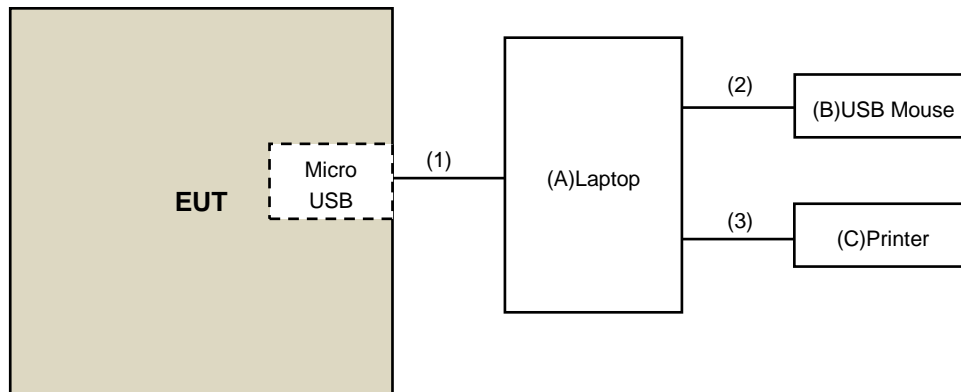

4.2 Configuration of Peripheral Devices and Cable Connections

ID	Product	Brand	Model No.	Serial No.	FCC ID	Remarks
A.	Laptop	DELL	P70F	1KY07L2	FCC DoC	Provided by Lab
B.	USB Mouse	DELL	MOC5UO	I1401MMP	FCC DoC	Provided by Lab
C.	Printer	EPSON	LQ-300+II	G88Y074085	FCC DoC	Provided by Lab

Note:

- All power cords of the above support units are non-shielded (1.8m).

ID	Descriptions	Qty.	Length (m)	Shielding (Yes/No)	Cores (Qty.)	Remarks
1.	USB to Micro USB Cable	1	1	Yes	0	Supplied by client
2.	USB Cable	1	1.8	Yes	0	Provided by Lab
3.	USB Cable	1	1.8	Yes	0	Provided by Lab

5 Conducted Emissions at Mains Ports

5.1 Limits

Frequency (MHz)	Class A (dBuV)		Class B (dBuV)	
	Quasi-peak	Average	Quasi-peak	Average
0.15 - 0.5	79	66	66 - 56	56 - 46
0.50 - 5.0	73	60	56	46
5.0 - 30.0	73	60	60	50

Notes: 1. The lower limit shall apply at the transition frequencies.
 2. The limit decreases linearly with the logarithm of the frequency in the range of 0.15 to 0.50 MHz.

5.2 Test Instruments

DESCRIPTION & MANUFACTURER	MODEL NO.	SERIAL NO.	CALIBRATED DATE	CALIBRATED UNTIL
Test Receiver R&S	ESCS 30	100375	May 15, 2019	May 14, 2020
Line-Impedance Stabilization Network (for EUT) SCHWARZBECK	NSLK-8127	8127-522	Sep. 03, 2018	Sep. 02, 2019
Line-Impedance Stabilization Network (for Peripheral) SCHWARZBECK	NSLK-8127	8127-523	Oct. 19, 2018	Oct. 18, 2019
RF Cable	5D-FB	COACAB-002	Feb. 22, 2019	Feb. 21, 2020
10 dB PAD EMEC	STI02-2200-10	004	Mar. 14, 2019	Mar. 13, 2020
50 ohms Terminator	N/A	EMC-03	Sep. 25, 2018	Sep. 24, 2019
50 ohms Terminator	N/A	EMC-02	Sep. 12, 2018	Sep. 11, 2019
Software BVADT	BVADT_Cond_ V7.3.7.4	NA	NA	NA

Note:

1. The calibration interval of the above test instruments are 12 months and the calibrations are traceable to NML/ROC and NIST/USA.
2. The test was performed in Conducted Room C
3. The VCCI Con C Registration No. is C-13611.
4. Tested Date: June 13, 2019

5.3 Test Arrangement

- The EUT was placed 0.4 meters from the conducting wall of the shielded room with EUT being connected to the power mains through a line impedance stabilization network (LISN). Other support units were connected to the power mains through another LISN. The two LISNs provide 50 Ohm/ 50uH of coupling impedance for the measuring instrument.
- Both lines of the power mains connected to the EUT were checked for maximum conducted interference.
- The test results of conducted emissions at mains ports are recorded of six worst margins for quasi-peak (mandatory) [and average (if necessary)] values against the limits at frequencies of interest unless the margin is 20 dB or greater.

Note: The resolution bandwidth and video bandwidth of test receiver is 9kHz for quasi-peak detection (QP) and average detection (AV) at frequency 0.15MHz-30MHz.

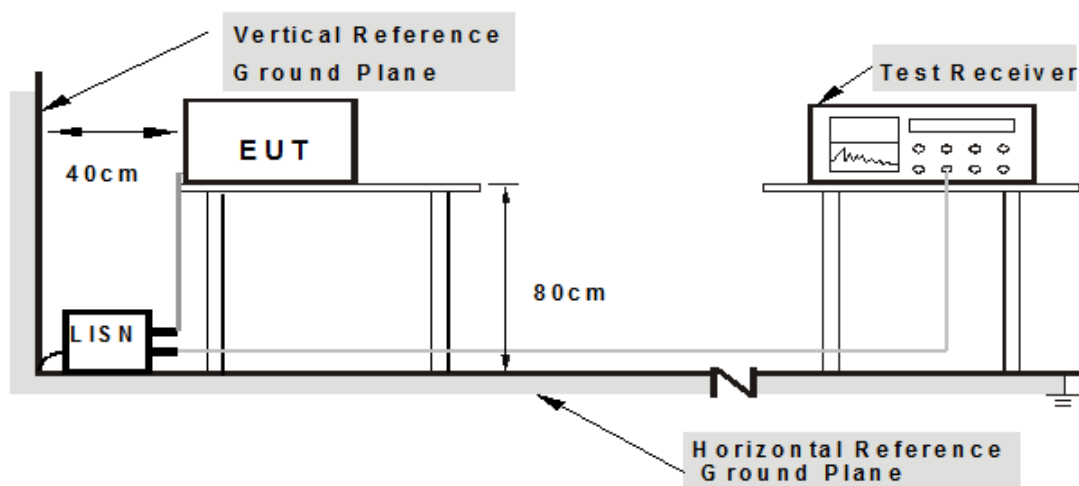

Note: 1.Support units were connected to second LISN.

For the actual test configuration, please refer to the related Item – Photographs of the Test Configuration.

5.4 Supplementary Information

There is not any deviation from the test standards for the test method.

5.5 Test Results

Frequency Range	150kHz ~ 30MHz	Detector Function & Resolution Bandwidth	Quasi-Peak (QP) / Average (AV), 9kHz
Input Power (System)	120Vac, 60Hz	Environmental Conditions	25°C, 66%RH
Tested by	Eagle Chen		
Test Mode	Mode 1		

Phase Of Power : Line (L)										
No	Frequency (MHz)	Correction Factor (dB)	Reading Value (dBuV)		Emission Level (dBuV)		Limit (dBuV)		Margin (dB)	
			Q.P.	AV.	Q.P.	AV.	Q.P.	AV.	Q.P.	AV.
1	0.15391	10.01	35.21	20.62	45.22	30.63	65.79	55.79	-20.57	-25.16
2	0.17344	10.01	36.05	15.82	46.06	25.83	64.79	54.79	-18.73	-28.96
3	0.60703	10.06	21.48	8.83	31.54	18.89	56.00	46.00	-24.46	-27.11
4	0.74766	10.07	21.18	8.89	31.25	18.96	56.00	46.00	-24.75	-27.04
5	7.94531	10.39	26.04	17.79	36.43	28.18	60.00	50.00	-23.57	-21.82
6	8.82031	10.42	23.84	16.67	34.26	27.09	60.00	50.00	-25.74	-22.91

Remarks:

1. Q.P. and AV. are abbreviations of quasi-peak and average individually.
2. The emission levels of other frequencies were very low against the limit.
3. Margin value = Emission level – Limit value
4. Correction factor = Insertion loss + Cable loss
5. Emission Level = Correction Factor + Reading Value

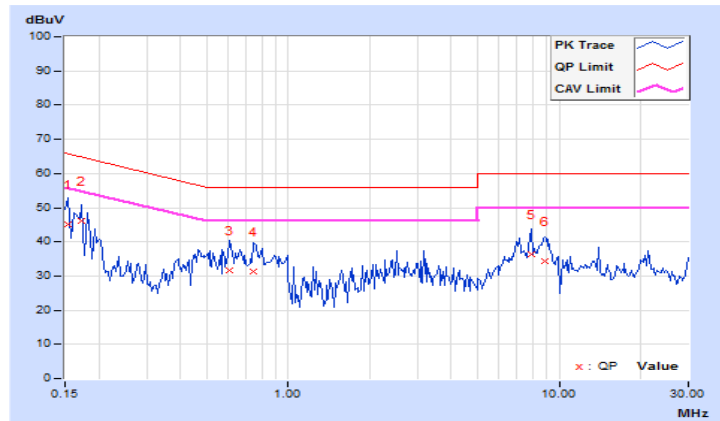

Frequency Range	150kHz ~ 30MHz	Detector Function & Resolution Bandwidth	Quasi-Peak (QP) / Average (AV), 9kHz
Input Power (System)	120Vac, 60Hz	Environmental Conditions	25°C, 66%RH
Tested by	Eagle Chen		
Test Mode	Mode 1		

Phase Of Power : Neutral (N)										
No	Frequency (MHz)	Correction Factor (dB)	Reading Value (dBuV)		Emission Level (dBuV)		Limit (dBuV)		Margin (dB)	
			Q.P.	AV.	Q.P.	AV.	Q.P.	AV.	Q.P.	AV.
1	0.15000	10.01	35.64	20.50	45.65	30.51	66.00	56.00	-20.35	-25.49
2	0.16953	10.01	34.99	17.17	45.00	27.18	64.98	54.98	-19.98	-27.80
3	0.63047	10.06	21.01	8.90	31.07	18.96	56.00	46.00	-24.93	-27.04
4	0.75938	10.06	18.75	8.76	28.81	18.82	56.00	46.00	-27.19	-27.18
5	6.55859	10.29	22.15	15.35	32.44	25.64	60.00	50.00	-27.56	-24.36
6	13.69922	10.46	19.31	13.55	29.77	24.01	60.00	50.00	-30.23	-25.99

Remarks:

1. Q.P. and AV. are abbreviations of quasi-peak and average individually.
2. The emission levels of other frequencies were very low against the limit.
3. Margin value = Emission level – Limit value
4. Correction factor = Insertion loss + Cable loss
5. Emission Level = Correction Factor + Reading Value

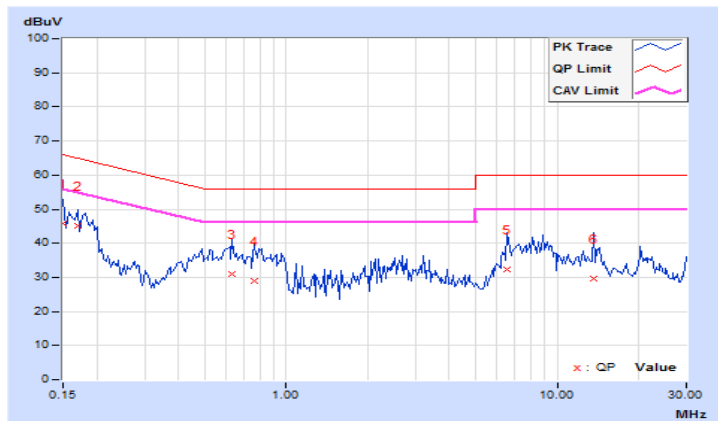

6 Radiated Emissions up to 1 GHz

6.1 Limits

Emissions radiated outside of the specified bands, shall be according to the general radiated limits as following:

Radiated Emissions Limits at 10 meters (dB μ V/m)				
Frequencies (MHz)	FCC 15B / ICES-003, Class A	FCC 15B / ICES-003, Class B	CISPR 22, Class A	CISPR 22, Class B
30-88	39	29.5	40	30
88-216	43.5	33.1		
216-230	46.4	35.6		
230-960			47	37
960-1000	49.5	43.5		

Radiated Emissions Limits at 3 meters (dB μ V/m)				
Frequencies (MHz)	FCC 15B / ICES-003, Class A	FCC 15B / ICES-003, Class B	CISPR 22, Class A	CISPR 22, Class B
30-88	49.5	40	50.5	40.5
88-216	54	43.5		
216-230	56.9	46		
230-960			57.5	47.5
960-1000	60	54		

- Notes: 1. The lower limit shall apply at the transition frequencies.
 2. Emission level (dB μ V/m) = 20 log Emission level (uV/m).
 3. QP detector shall be applied if not specified.

6.2 Test Instruments

DESCRIPTION & MANUFACTURER	MODEL NO.	SERIAL NO.	CALIBRATED DATE	CALIBRATED UNTIL
Test Receiver Agilent	N9038A	MY50010125	Apr. 11, 2019	Apr. 10, 2020
Test Receiver R&S	ESR3	102528	Feb. 22, 2019	Feb. 21, 2020
Pre-Amplifier Sonoma	310N	352925	Aug. 27, 2018	Aug. 26, 2019
	310N	352926	Aug. 27, 2018	Aug. 26, 2019
Trilog Broadband Antenna SCHWARZBECK	VULB 9168	9168-359	Nov. 22, 2018	Nov. 21, 2019
	VULB 9168	9168-358	Nov. 21, 2018	Nov. 20, 2019
Fixed attenuator Mini-Circuits	UNAT-5+	CHF-001	Sep. 05, 2018	Sep. 04, 2019
	UNAT-5+	CHF-002	Sep. 05, 2018	Sep. 04, 2019
RF Cable	8D-FB	CHFCAB-001-1 CHFCAB-001-3 CHFCAB-001-4	Sep. 17, 2018	Sep. 16, 2019
		CHFCAB-002-1 CHFCAB-002-3 CHFCAB-002-4	Sep. 17, 2018	Sep. 16, 2019
Software BVADT	ADT_Radiated_V8.7.08	NA	NA	NA
Antenna Tower & Turn Table CT	NA	NA	NA	NA

Note:

1. The calibration interval of the above test instruments are 12 months and the calibrations are traceable to NML/ROC and NIST/USA.
2. The test was performed in Chamber F room
3. The VCCI Site Registration No. is R-13252.
4. Tested Date: June 13, 2019

6.3 Test Arrangement

- The EUT was placed on the top of a rotating table 0.8 meters above the ground at an accredited test facility. The table was rotated 360 degrees to determine the position of the highest radiation.
- The EUT was set 10 meters away from the interference-receiving antenna, which was mounted on the top of a variable-height antenna tower.
- The antenna is a broadband antenna, and its height is varied from one meter to four meters above the ground to determine the maximum value of the field strength. Both horizontal and vertical polarizations of the antenna are set to make the measurement.
- For each suspected emission, the EUT was arranged to its worst case and then the antenna was tuned to heights from 1 meter to 4 meters and the rotatable table was turned from 0 degrees to 360 degrees to find the maximum reading.
- The test-receiver system was set to quasi-peak detect function and specified bandwidth with maximum hold mode when the test frequency is up to 1 GHz.

Note: The resolution bandwidth and video bandwidth of test receiver/spectrum analyzer is 120kHz for quasi-peak detection (QP) at frequency up to 1GHz.

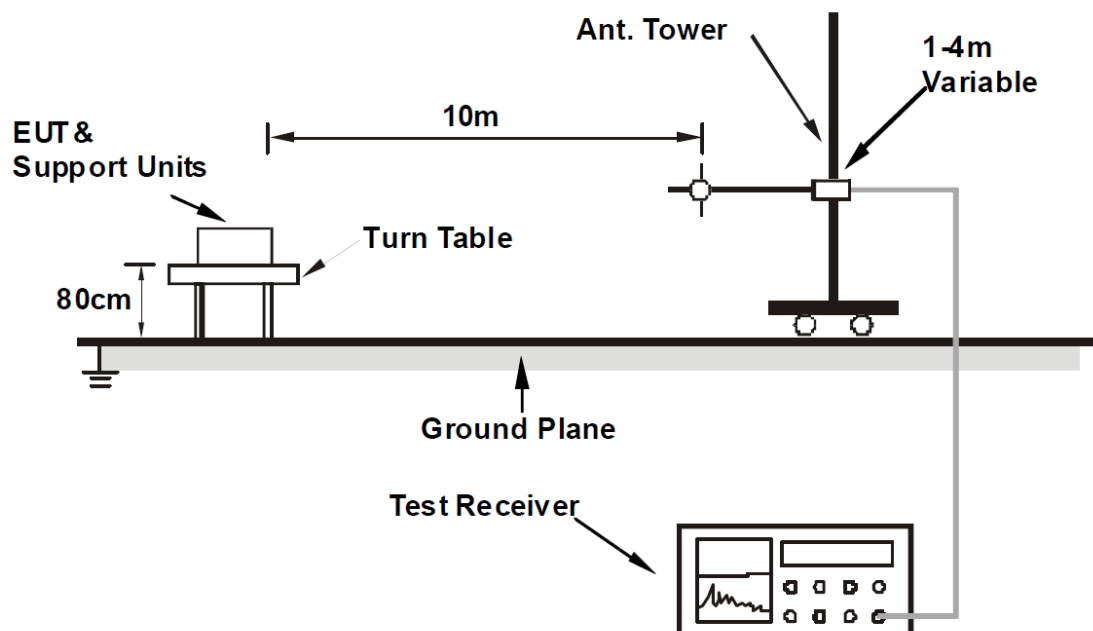

For the actual test configuration, please refer to the related Item – Photographs of the Test Configuration.

6.4 Supplementary Information

There is not any deviation from the test standards for the test method.

6.5 Test Results

Frequency Range	30MHz ~ 1GHz	Detector Function & Resolution Bandwidth	Quasi-Peak (QP), 120kHz
Input Power	5Vdc	Environmental Conditions	25°C, 69%RH
Tested by	Eagle Chen		
Test Mode	Mode 1		

Antenna Polarity & Test Distance : Horizontal at 10 m								
No	Frequency (MHz)	Emission Level (dBuV/m)	Limit (dBuV/m)	Margin (dB)	Antenna Height (m)	Table Angle (Degree)	Raw Value (dBuV)	Correction Factor (dB/m)
1	30.11	23.90 QP	30.00	-6.10	4.00 H	42	38.37	-14.47
2	243.79	30.19 QP	37.00	-6.81	4.00 H	14	43.38	-13.19
3	270.85	34.82 QP	37.00	-2.18	3.93 H	236	47.03	-12.21
4	569.95	32.64 QP	37.00	-4.36	2.00 H	14	37.09	-4.45
5	595.22	31.44 QP	37.00	-5.56	2.00 H	52	35.14	-3.70
6	748.96	32.33 QP	37.00	-4.67	1.00 H	217	32.94	-0.61

Remarks:

1. Emission Level(dBuV/m) = Raw Value(dBuV) + Correction Factor(dB/m)
2. Correction Factor(dB/m) = Antenna Factor (dB/m) + Cable Factor (dB)
– Pre-Amplifier Factor (dB)
3. The other emission levels were very low against the limit.
4. Margin value = Emission level – Limit value

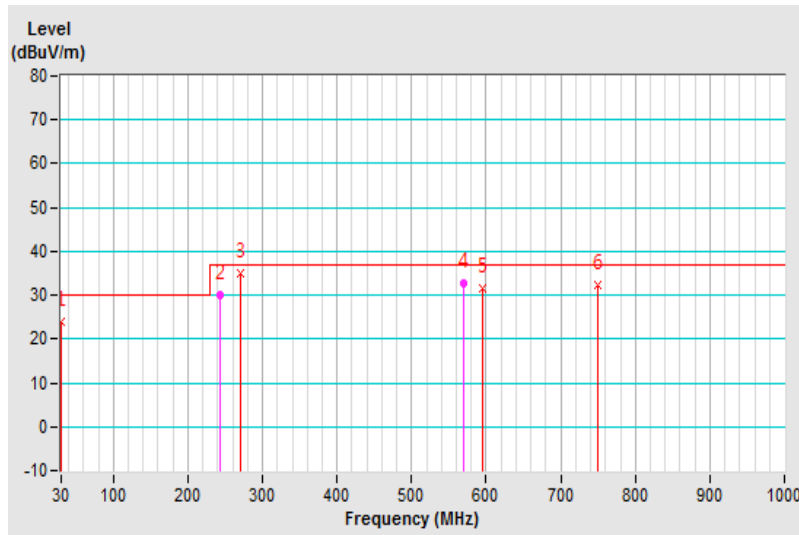

Frequency Range	30MHz ~ 1GHz	Detector Function & Resolution Bandwidth	Quasi-Peak (QP), 120kHz
Input Power	5Vdc	Environmental Conditions	25°C, 69%RH
Tested by	Eagle Chen		
Test Mode	Mode 1		

Antenna Polarity & Test Distance : Vertical at 10 m								
No	Frequency (MHz)	Emission Level (dBuV/m)	Limit (dBuV/m)	Margin (dB)	Antenna Height (m)	Table Angle (Degree)	Raw Value (dBuV)	Correction Factor (dB/m)
1	39.75	25.11 QP	30.00	-4.89	1.00 V	103	38.57	-13.46
2	166.58	21.67 QP	30.00	-8.33	2.00 V	201	34.01	-12.34
3	268.96	31.29 QP	37.00	-5.71	1.00 V	348	43.10	-11.81
4	596.24	29.34 QP	37.00	-7.66	1.00 V	228	32.45	-3.11
5	750.81	33.37 QP	37.00	-3.63	4.00 V	294	33.68	-0.31
6	996.65	31.06 QP	37.00	-5.94	2.00 V	41	26.77	4.29

Remarks:

1. Emission Level(dBuV/m) = Raw Value(dBuV) + Correction Factor(dB/m)
2. Correction Factor(dB/m) = Antenna Factor (dB/m) + Cable Factor (dB)
– Pre-Amplifier Factor (dB)
3. The other emission levels were very low against the limit.
4. Margin value = Emission level – Limit value

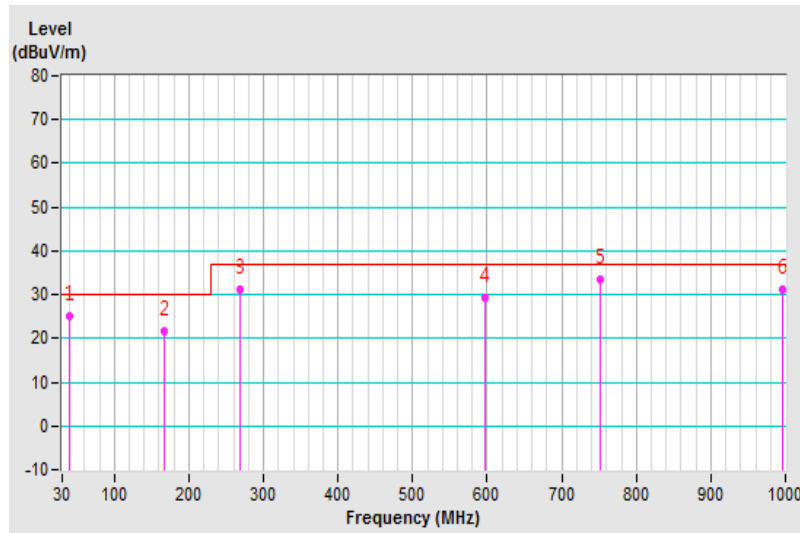

7 Radiated Emissions above 1 GHz

7.1 Limits

Emissions radiated outside of the specified bands, shall be according to the general radiated limits as following:

Radiated Emissions Limits at 10 meters (dB μ V/m)				
Frequencies (MHz)	FCC 15B / ICES-003, Class A	FCC 15B / ICES-003, Class B	CISPR 22, Class A	CISPR 22, Class B
1000-3000	Avg: 49.5	Avg: 43.5	Not defined	Not defined
Above 3000	Peak: 69.5	Peak: 63.5	Not defined	Not defined

Radiated Emissions Limits at 3 meters (dB μ V/m)				
Frequencies (MHz)	FCC 15B / ICES-003, Class A	FCC 15B / ICES-003, Class B	CISPR 22, Class A	CISPR 22, Class B
1000-3000	Avg: 60 Peak: 80	Avg: 54 Peak: 74	Avg: 56 Peak: 76	Avg: 50 Peak: 70
Above 3000			Avg: 60 Peak: 80	Avg: 54 Peak: 74

- Notes:
1. The lower limit shall apply at the transition frequencies.
 2. Emission level (dB μ V/m) = 20 log Emission level (uV/m).
 3. As shown in 15.35(b), for frequencies above 1000MHz, the field strength limits are based on average detector, however, the peak field strength of any emission shall not exceed the maximum permitted average limits, specified above by more than 20dB under any condition of modulation.

Frequency Range (For unintentional radiators)

Highest frequency generated or used in the device or on which the device operates or tunes (MHz)	Upper frequency of measurement range (MHz)
Below 1.705	30
1.705-108	1000
108-500	2000
500-1000	5000
Above 1000	5th harmonic of the highest frequency or 40GHz, whichever is lower

7.2 Test Instruments

DESCRIPTION & MANUFACTURER	MODEL NO.	SERIAL NO.	CALIBRATED DATE	CALIBRATED UNTIL
Test Receiver Agilent	N9038A	MY50010125	Apr. 11, 2019	Apr. 10, 2020
Pre-Amplifier Agilent	8449B	3008A01975	Feb. 21, 2019	Feb. 20, 2020
Horn Antenna SCHWARZBECK	BBHA 9120D	D123	Nov. 25, 2018	Nov. 24, 2019
RF Coaxial Cable	EMC104-SM-SM-11000	170209	Mar. 05, 2019	Mar. 04, 2020
RF Coaxial Cable	EMC104-SM-SM-6000	170207	Mar. 05, 2019	Mar. 04, 2020
RF Coaxial Cable	EMC104-SM-SM-2500	170206	Mar. 05, 2019	Mar. 04, 2020
Software BVADT	ADT_Radiated_ V8.7.08	NA	NA	NA
Antenna Tower & Turn Table CT	NA	NA	NA	NA
Fix tool for Boresight antenna tower	BAF-01	5	NA	NA

Note:

1. The calibration interval of the above test instruments are 12 months and the calibrations are traceable to NML/ROC and NIST/USA.
2. The test was performed in Chamber F room
3. Tested Date: June 13, 2019

7.3 Test Arrangement

- The EUT was placed on the top of a rotating table 0.8 meters above the ground at an accredited chamber room. The table was rotated 360 degrees to determine the position of the highest radiation.
- The EUT was set 3 meters away from the interference-receiving antenna, which was mounted on the top of a variable-height antenna tower.
- The height of antenna can be varied from one meter to four meters, the height of adjustment depends on the EUT height and the antenna 3dB beamwidth both, to detect the maximum value of the field strength. Both horizontal and vertical polarizations of the antenna are set to make the measurement.
- For each suspected emission, the EUT was arranged to its worst case and then the antenna was tuned to heights and the rotatable table was turned from 0 degrees to 360 degrees to find the maximum reading.
- The spectrum analyzer system was set to peak and average detect function and specified bandwidth with maximum hold mode when the test frequency is above 1 GHz.

Note: The resolution bandwidth of test receiver/spectrum analyzer is 1MHz and video bandwidth is 3MHz for Peak detection (PK) at frequency above 1GHz. The resolution bandwidth of test receiver/spectrum analyzer is 1 MHz for Average detection (AV) at frequency above 1GHz.

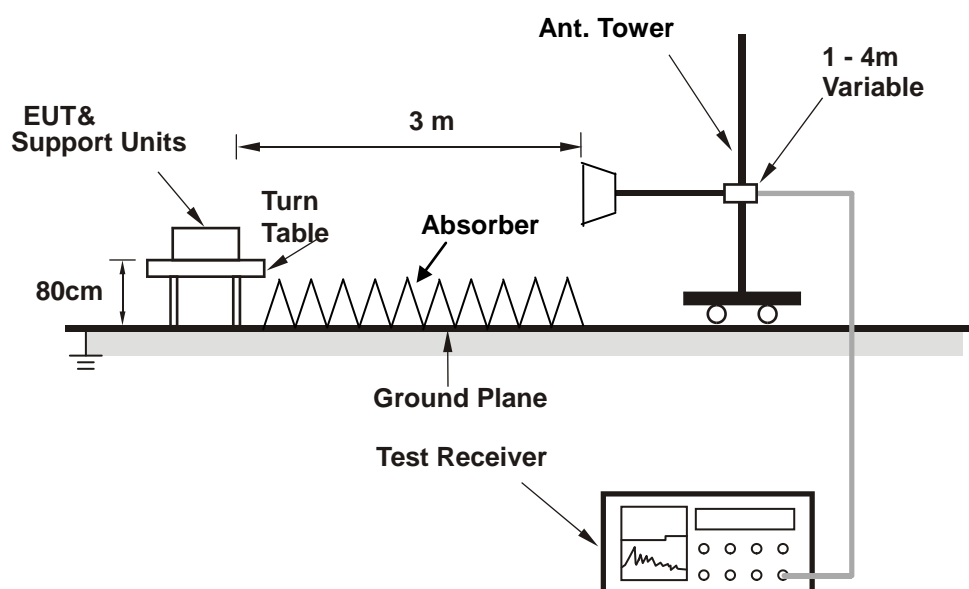

The test arrangement is in accordance with ANSI 63.4:2014. For the actual test configuration, please refer to the related item – Photographs of the Test Configuration.

7.4 Supplementary Information

There is not any deviation from the test standards for the test method.

7.5 Test Results

Frequency Range	1GHz ~ 12.5GHz	Detector Function & Resolution Bandwidth	Peak (PK) / Average (AV), 1MHz
Input Power	5Vdc	Environmental Conditions	26°C, 65%RH
Tested by	Eagle Chen		
Test Mode	Mode 1		

Antenna Polarity & Test Distance : Horizontal at 3 m

No	Frequency (MHz)	Emission Level (dBuV/m)	Limit (dBuV/m)	Margin (dB)	Antenna Height (m)	Table Angle (Degree)	Raw Value (dBuV)	Correction Factor (dB/m)
1	1170.00	39.69 PK	74.00	-34.31	1.00 H	21	43.51	-3.82
2	1170.00	24.91 AV	54.00	-29.09	1.00 H	128	28.73	-3.82
3	1997.05	40.96 PK	74.00	-33.04	1.00 H	96	41.16	-0.20
4	1997.05	27.59 AV	54.00	-26.41	1.00 H	275	27.79	-0.20
5	4245.30	44.35 PK	74.00	-29.65	1.00 H	360	36.63	7.72
6	4245.30	30.77 AV	54.00	-23.23	1.00 H	286	23.05	7.72
7	4791.43	48.12 PK	74.00	-25.88	1.00 H	202	34.61	13.51
8	4791.43	35.03 AV	54.00	-18.97	1.00 H	0	21.52	13.51
9	6657.18	48.40 PK	74.00	-25.60	1.00 H	246	34.13	14.27
10	6657.18	35.08 AV	54.00	-18.92	1.00 H	0	20.81	14.27
11	7983.60	52.42 PK	74.00	-21.58	1.00 H	282	34.73	17.69
12	7983.60	38.37 AV	54.00	-15.63	1.00 H	116	20.68	17.69

Remarks:

1. Emission Level(dBuV/m) = Raw Value(dBuV) + Correction Factor(dB/m)
2. Correction Factor(dB/m) = Antenna Factor (dB/m) + Cable Factor (dB)
– Pre-Amplifier Factor (dB)
3. The other emission levels were very low against the limit.
4. Margin value = Emission level – Limit value

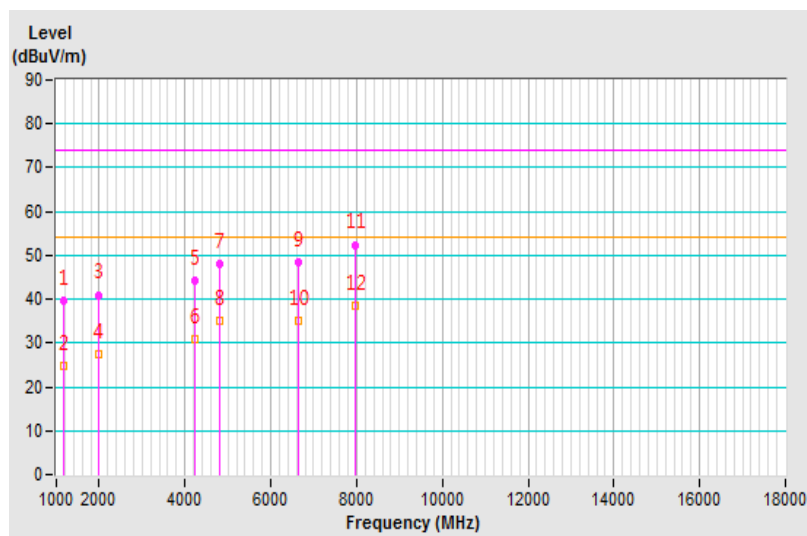

Frequency Range	1GHz ~ 12.5GHz	Detector Function & Resolution Bandwidth	Peak (PK) / Average (AV), 1MHz
Input Power	5Vdc	Environmental Conditions	26°C, 65%RH
Tested by	Eagle Chen		
Test Mode	Mode 1		

Antenna Polarity & Test Distance : Vertical at 3 m								
No	Frequency (MHz)	Emission Level (dBuV/m)	Limit (dBuV/m)	Margin (dB)	Antenna Height (m)	Table Angle (Degree)	Raw Value (dBuV)	Correction Factor (dB/m)
1	1768.83	48.45 PK	74.00	-25.55	1.00 V	360	50.33	-1.88
2	1768.83	24.52 AV	54.00	-29.48	1.00 V	193	26.40	-1.88
3	2989.85	46.21 PK	74.00	-27.79	1.00 V	202	42.66	3.55
4	2989.85	28.90 AV	54.00	-25.10	1.00 V	103	25.35	3.55
5	3329.85	45.13 PK	74.00	-28.87	1.00 V	302	41.47	3.66
6	3329.85	29.59 AV	54.00	-24.41	1.00 V	123	25.93	3.66
7	4813.10	47.09 PK	74.00	-26.91	1.00 V	147	38.52	8.57
8	4813.10	34.22 AV	54.00	-19.78	1.00 V	28	25.65	8.57
9	8680.17	52.15 PK	74.00	-21.85	1.00 V	113	33.03	19.12
10	8680.17	39.25 AV	54.00	-14.75	1.00 V	90	20.13	19.12
11	11469.87	56.61 PK	74.00	-17.39	1.00 V	53	31.91	24.70
12	11469.87	44.02 AV	54.00	-9.98	1.00 V	262	19.32	24.70

Remarks:

1. Emission Level(dBuV/m) = Raw Value(dBuV) + Correction Factor(dB/m)
2. Correction Factor(dB/m) = Antenna Factor (dB/m) + Cable Factor (dB) – Pre-Amplifier Factor (dB)
3. The other emission levels were very low against the limit.
4. Margin value = Emission level – Limit value

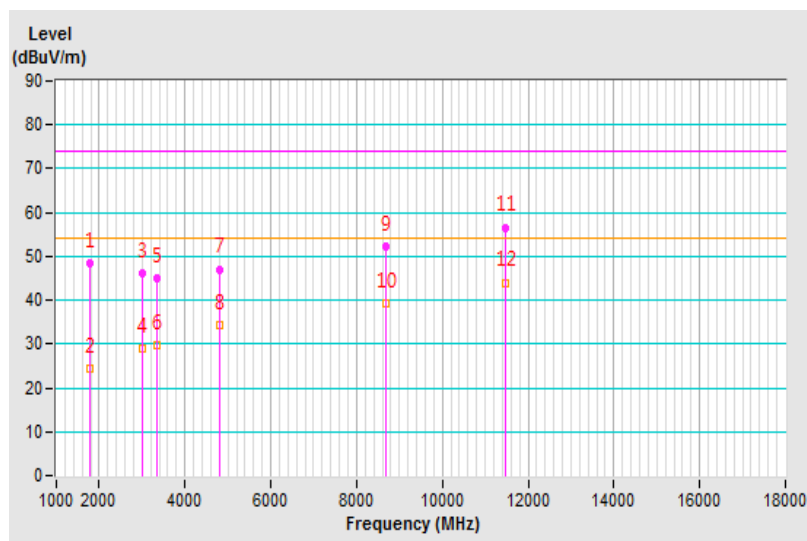

8 Pictures of Test Arrangements

Please refer to the attached file (Test Setup Photo).

Appendix – Information of the Testing Laboratories

We, Bureau Veritas Consumer Products Services (H.K.) Ltd., Taoyuan Branch, were founded in 1988 to provide our best service in EMC, Radio, Telecom and Safety consultation. Our laboratories are FCC recognized accredited test firms and accredited according to ISO/IEC 17025.

If you have any comments, please feel free to contact us at the following:

Lin Kou EMC/RF Lab

Tel: 886-2-26052180

Fax: 886-2-26051924

Hsin Chu EMC/RF/Telecom Lab

Tel: 886-3-6668565

Fax: 886-3-6668323

Hwa Ya EMC/RF/Safety Lab

Tel: 886-3-3183232

Fax: 886-3-3270892

Email: service.adt@tw.bureauveritas.com

Web Site: www.bureauveritas-adt.com

The address and road map of all our labs can be found in our web site also.

--- END ---