

## FCC Test Report (5GHz WLAN)

**Report No.:** RFBEMI-WTW-P21080520-1

**FCC ID:** NOIKBN778K

**Test Model:** N778K

**Received Date:** 2021/8/11

**Test Date:** 2021/10/5 ~ 2021/10/30

**Issued Date:** 2021/11/18

**Applicant:** NETRONIX, INC.

**Address:** No 945, Boai St, Jubei City, Hsinchu, 30265 Taiwan

**Issued By:** Bureau Veritas Consumer Products Services (H.K.) Ltd., Taoyuan Branch  
Lin Kou Laboratories

**Lab Address:** No. 47-2, 14th Ling, Chia Pau Vil., Lin Kou Dist., New Taipei City, Taiwan

**FCC Registration /  
Designation Number:** 198487 / TW2021



This report is for your exclusive use. Any copying or replication of this report to or for any other person or entity, or use of our name or trademark, is permitted only with our prior written permission. This report sets forth our findings solely with respect to the test samples identified herein. The results set forth in this report are not indicative or representative of the quality or characteristics of the lot from which a test sample was taken or any similar or identical product unless specifically and expressly noted. Our report includes all of the tests requested by you and the results thereof based upon the information that you provided to us. You have 60 days from date of issuance of this report to notify us of any material error or omission caused by our negligence, provided, however, that such notice shall be in writing and shall specifically address the issue you wish to raise. A failure to raise such issue within the prescribed time shall constitute your unqualified acceptance of the completeness of this report, the tests conducted and the correctness of the report contents. Unless specific mention, the uncertainty of measurement has been explicitly taken into account to declare the compliance or non-compliance to the specification.

## Table of Contents

<b>Release Control Record</b> .....	<b>4</b>
<b>1 Certificate of Conformity</b> .....	<b>5</b>
<b>2 Summary of Test Results</b> .....	<b>6</b>
2.1 Measurement Uncertainty .....	6
2.2 Modification Record .....	6
<b>3 General Information</b> .....	<b>7</b>
3.1 General Description of EUT .....	7
3.2 Description of Test Modes .....	9
3.2.1 Test Mode Applicability and Tested Channel Detail .....	10
3.3 Duty Cycle of Test Signal .....	12
3.4 Description of Support Units .....	13
3.4.1 Configuration of System under Test .....	13
3.5 General Description of Applied Standard and References .....	14
<b>4 Test Types and Results</b> .....	<b>15</b>
4.1 Radiated Emission and Bandedge Measurement.....	15
4.1.1 Limits of Radiated Emission and Bandedge Measurement .....	15
4.1.2 Test Instruments .....	16
4.1.3 Test Procedure .....	17
4.1.4 Deviation from Test Standard .....	17
4.1.5 Test Setup.....	18
4.1.6 EUT Operating Condition .....	19
4.1.7 Test Results .....	20
4.2 Conducted Emission Measurement .....	40
4.2.1 Limits of Conducted Emission Measurement .....	40
4.2.2 Test Instruments .....	40
4.2.3 Test Procedure .....	41
4.2.4 Deviation from Test Standard .....	41
4.2.5 Test Setup.....	41
4.2.6 EUT Operating Condition .....	41
4.2.7 Test Results .....	42
4.3 Transmit Power Measurement .....	46
4.3.1 Limits of Transmit Power Measurement .....	46
4.3.2 Test Setup.....	47
4.3.3 Test Instruments .....	47
4.3.4 Test Procedure .....	47
4.3.5 Deviation from Test Standard .....	47
4.3.6 EUT Operating Condition .....	47
4.3.7 Test Result .....	48
4.4 Occupied Bandwidth Measurement .....	49
4.4.1 Test Setup.....	49
4.4.2 Test Instruments .....	49
4.4.3 Test Procedure .....	49
4.4.4 Test Results .....	50
4.5 Peak Power Spectral Density Measurement .....	54
4.5.1 Limits of Peak Power Spectral Density Measurement .....	54
4.5.2 Test Setup.....	54
4.5.3 Test Instruments .....	54
4.5.4 Test Procedure .....	54
4.5.5 Deviation from Test Standard .....	54
4.5.6 EUT Operating Condition .....	54
4.5.7 Test Results .....	55
4.6 Frequency Stability Measurement.....	59

4.6.1	Limits of Frequency Stability Measurement .....	59
4.6.2	Test Setup.....	59
4.6.3	Test Instruments .....	59
4.6.4	Test Procedure .....	59
4.6.5	Deviation from Test Standard .....	59
4.6.6	EUT Operating Condition .....	59
4.6.7	Test Results .....	60
4.7	6dB Bandwidth Measurement .....	61
4.7.1	Limits of 6dB Bandwidth Measurement.....	61
4.7.2	Test Setup.....	61
4.7.3	Test Instruments .....	61
4.7.4	Test Procedure .....	61
4.7.5	Deviation from Test Standard .....	61
4.7.6	EUT Operating Condition .....	61
4.7.7	Test Results .....	62
<b>5</b>	<b>Pictures of Test Arrangements.....</b>	<b>64</b>
	<b>Annex A- Radiated Out of Band Emission (OOBE) Measurement (For U-NII-3 band).....</b>	<b>65</b>
	<b>Annex B- Band Edge Measurement.....</b>	<b>68</b>
	<b>Appendix – Information of the Testing Laboratories .....</b>	<b>74</b>



### Release Control Record

Issue No.	Description	Date Issued
RFBEMI-WTW-P21080520-1	Original release.	2021/11/18

## 1 Certificate of Conformity

**Product:** Electronic Display Device

**Brand:** Rakuten kobo

**Test Model:** N778K

**Sample Status:** Engineering sample

**Applicant:** NETRONIX, INC.

**Test Date:** 2021/10/5 ~ 2021/10/30

**Standard:** 47 CFR FCC Part 15, Subpart E (Section 15.407)  
ANSI C63.10: 2013

The above equipment has been tested by **Bureau Veritas Consumer Products Services (H.K.) Ltd., Taoyuan Branch**, and found compliance with the requirement of the above standards. The test record, data evaluation & Equipment Under Test (EUT) configurations represented herein are true and accurate accounts of the measurements of the sample's RF characteristics under the conditions specified in this report.

**Prepared by :**

*Jessica Cheng*

**Date:**

2021/11/18

Jessica Cheng / Senior Specialist

**Approved by :**

*Jeremy Lin*

**Date:**

2021/11/18

Jeremy Lin / Project Engineer

## 2 Summary of Test Results

47 CFR FCC Part 15, Subpart E (Section 15.407)			
FCC Clause	Test Item	Result	Remarks
15.407(b)(9)	AC Power Conducted Emissions	Pass	Meet the requirement of limit. Minimum passing margin is -20.24dB at 8.31600MHz.
15.407(b)(1/2/3/4(i/ii)/9)	Radiated Emissions & Band Edge Measurement	Pass	Meet the requirement of limit. Minimum passing margin is -0.16dB at 5150.00MHz.
15.407(a)(1/2/3)	Max Average Transmit Power	Pass	Meet the requirement of limit.
---	Occupied Bandwidth Measurement	Reference only.	
15.407(a)(1/2/3)	Peak Power Spectral Density	Pass	Meet the requirement of limit.
15.407(e)	6dB bandwidth	Pass	Meet the requirement of limit. (U-NII-3 Band only)
15.407(g)	Frequency Stability	Pass	Meet the requirement of limit.
15.203	Antenna Requirement	Pass	No antenna connector is used.

### Note:

- Determining compliance based on the results of the compliance measurement, not taking into account measurement instrumentation uncertainty.
- For U-NII-3 band compliance with rule part 15.407(b)(4)(i), the OOB test plots were recorded in Annex A.
- For U-NII-1 band compliance with rule 15.407(b) of the band-edge items, the test plots were recorded in Annex B. Test Procedures refer to report 4.1.3.

### 2.1 Measurement Uncertainty

Where relevant, the following measurement uncertainty levels have been estimated for tests performed on the EUT as specified in CISPR 16-4-2:

Measurement	Frequency	Expanded Uncertainty (k=2) ( $\pm$ )
Conducted Emissions at mains ports	150kHz ~ 30MHz	3.00 dB
Conducted Emissions	9kHz ~ 40GHz	2.63 dB
Radiated Emissions up to 1 GHz	9kHz ~ 30MHz	2.38 dB
	30MHz ~ 1GHz	5.70 dB
Radiated Emissions above 1 GHz	Above 1GHz	5.21 dB

### 2.2 Modification Record

There were no modifications required for compliance.

### 3 General Information

#### 3.1 General Description of EUT

Product	Electronic Display Device
Brand	Rakuten kobo
Test Model	N778K
Status of EUT	Engineering sample
Power Supply Rating	3.7Vdc from Battery or 5Vdc from USB interface
Modulation Type	64QAM, 16QAM, QPSK, BPSK for OFDM 256QAM for OFDM in 11ac mode
Modulation Technology	OFDM
Transfer Rate	802.11a: up to 54Mbps 802.11n: up to 150Mbps 802.11ac: up to 433.3Mbps
Operating Frequency	5180 ~ 5240MHz, 5745 ~ 5825MHz
Number of Channel	<b>5180 ~ 5240MHz</b> 802.11a, 802.11n (HT20), 802.11ac (VHT20): 4 802.11n (HT40), 802.11ac (VHT40): 2 802.11ac (VHT80): 1 <b>5745 ~ 5825MHz</b> 802.11a, 802.11n (HT20), 802.11ac (VHT20): 5 802.11n (HT40), 802.11ac (VHT40): 2 802.11ac (VHT80): 1
Output Power	<b>5180 ~ 5240MHz:</b> 12.303mW <b>5745 ~ 5825MHz:</b> 4.266mW
Antenna Type	Refer to note as below
Antenna Connector	Refer to note as below
Accessory Device	N/A
Data Cable Supplied	Shielded USB cable (1.0m)

Note:

1. There are WLAN and Bluetooth technologies used for the EUT.
2. Simultaneously transmission condition.

Condition	Technology	
1	WLAN (2.4GHz)	Bluetooth
2	WLAN (5GHz)	Bluetooth

Note: The emission of the simultaneous operation has been evaluated and no non-compliances was found

3. Two eMMCs provided to the EUT, please refer to the following table:

No.	Model	Remark
1	EMMC32G-TX29-GA8A	1st source eMMC
2	MKEMF032GZ1E-C	2nd source eMMC

Note: From the above eMMCs the worst case was found in **No. 1**. Therefore only the test data of the mode was recorded in this report.

4. The following antennas were provided to the EUT.

Brand	Model	Gain (dBi)	Frequency range	Antenna Type	Antenna Connector
INPAQ	ACM3-3216-P1-CC-S	0.6	2.4~2.4835GHz	Chip	None
INPAQ	ACM3-3216-P1-CC-S	2	5.15~5.85GHz	Chip	None

5. The above Antenna information is declared by manufacturer and for more detailed features description, please refer to the manufacturer's specifications, the laboratory shall not be held responsible.

6. The EUT was pre-tested under the following modes:

Pre-test Mode	Test Condition
A	Battery mode,
B	USB Adapter mode
C	Notebook mode
<b>D</b>	<b>USB Adapter mode with Leather Sheath</b>

Note: From the above mode, the worst case was found in **Mode D**. Therefore only the test data of the mode was recorded in this report.

7. The EUT incorporates a SISO function.

5GHz Band		
Modulation Mode	TX & RX Configuration	
802.11a	1TX	1RX
802.11n (HT20)	1TX	1RX
802.11n (HT40)	1TX	1RX
802.11ac (VHT20)	1TX	1RX
802.11ac (VHT40)	1TX	1RX
802.11ac (VHT80)	1TX	1RX

8. The above EUT information is declared by manufacturer and for more detailed features description, please refer to the manufacturer's specifications or user's manual.



### 3.2 Description of Test Modes

#### 5180~5240MHz:

4 channels are provided for 802.11a, 802.11n (HT20), 802.11ac (VHT20):

Channel	Frequency	Channel	Frequency
36	5180 MHz	44	5220 MHz
40	5200 MHz	48	5240 MHz

2 channels are provided for 802.11n (HT40), 802.11ac (VHT40):

Channel	Frequency	Channel	Frequency
38	5190 MHz	46	5230 MHz

1 channel is provided for 802.11ac (VHT80):

Channel	Frequency
42	5210MHz

#### 5745~5825MHz:

5 channels are provided for 802.11a, 802.11n (HT20), 802.11ac (VHT20):

Channel	Frequency	Channel	Frequency
149	5745MHz	161	5805MHz
153	5765MHz	165	5825MHz
157	5785MHz		

2 channels are provided for 802.11n (HT40), 802.11ac (VHT40):

Channel	Frequency	Channel	Frequency
151	5755MHz	159	5795MHz

1 channel is provided for 802.11ac (VHT80):

Channel	Frequency
155	5775MHz

### 3.2.1 Test Mode Applicability and Tested Channel Detail

EUT Configure Mode	Applicable To				Description
	RE $\geq$ 1G	RE $<$ 1G	PLC	APCM	
A	√	√	√	√	USB Adapter mode with Leather Sheath
B	-	-	√	-	Notebook mode with Leather Sheath

Where **RE $\geq$ 1G**: Radiated Emission above 1GHz      **RE $<$ 1G**: Radiated Emission below 1GHz  
**PLC**: Power Line Conducted Emission      **APCM**: Antenna Port Conducted Measurement

**NOTE:** The EUT had been pre-tested on the positioned of each 3 axis. The worst case was found when positioned on **X-plane**.

#### **Radiated Emission Test (Above 1GHz):**

- Pre-Scan has been conducted to determine the worst-case mode from all possible combinations between available modulations, data rates and antenna ports (if EUT with antenna diversity architecture).
- Following channel(s) was (were) selected for the final test as listed below.

EUT Configure Mode	Mode	Frequency Band (MHz)	Available Channel	Tested Channel	Modulation Technology	Data Rate (Mbps)
A	802.11a	5180-5240	36 to 48	36, 40, 48	OFDM	6.0
	802.11ac (VHT20)		36 to 48	36, 40, 48	OFDM	6.5
	802.11ac (VHT40)		38 to 46	38, 46	OFDM	13.5
	802.11ac (VHT80)		42	42	OFDM	29.3
A	802.11a	5745-5825	149 to 165	149, 157, 165	OFDM	6.0
	802.11ac (VHT20)		149 to 165	149, 157, 165	OFDM	6.5
	802.11ac (VHT40)		151 to 159	151, 159	OFDM	13.5
	802.11ac (VHT80)		155	155	OFDM	29.3

#### **Radiated Emission Test (Below 1GHz):**

- Pre-Scan has been conducted to determine the worst-case mode from all possible combinations between available modulations, data rates and antenna ports (if EUT with antenna diversity architecture).
- Following channel(s) was (were) selected for the final test as listed below.

EUT Configure Mode	Mode	Frequency Band (MHz)	Available Channel	Tested Channel	Modulation Technology	Data Rate (Mbps)
A	802.11ac (VHT20)	5180-5240 5745-5825	36 to 48 149 to 165	165	OFDM	6.5

#### **Power Line Conducted Emission Test:**

- Pre-Scan has been conducted to determine the worst-case mode from all possible combinations between available modulations, data rates and antenna ports (if EUT with antenna diversity architecture).
- Following channel(s) was (were) selected for the final test as listed below.

EUT Configure Mode	Mode	Frequency Band (MHz)	Available Channel	Tested Channel	Modulation Technology	Data Rate (Mbps)
A & B	802.11ac (VHT20)	5180-5240 5745-5825	36 to 48 149 to 165	165	OFDM	6.5

**Antenna Port Conducted Measurement:**

- This item includes all test value of each mode, but only includes spectrum plot of worst value of each mode.
- Pre-Scan has been conducted to determine the worst-case mode from all possible combinations between available modulations, data rates and antenna ports (if EUT with antenna diversity architecture).
- Following channel(s) was (were) selected for the final test as listed below.

EUT Configure Mode	Mode	Frequency Band (MHz)	Available Channel	Tested Channel	Modulation Technology	Data Rate (Mbps)
A	802.11a	5180-5240	36 to 48	36, 40, 48	OFDM	6.0
	802.11ac (VHT20)		36 to 48	36, 40, 48	OFDM	6.5
	802.11ac (VHT40)		38 to 46	38, 46	OFDM	13.5
	802.11ac (VHT80)		42	42	OFDM	29.3
A	802.11a	5745-5825	149 to 165	149, 157, 165	OFDM	6.0
	802.11ac (VHT20)		149 to 165	149, 157, 165	OFDM	6.5
	802.11ac (VHT40)		151 to 159	151, 159	OFDM	13.5
	802.11ac (VHT80)		155	155	OFDM	29.3

**Test Condition:**

Applicable To	EUT Configure Mode	Environmental Conditions	Input Power	Tested By
RE $\geq$ 1G	A	23deg. C, 53%RH	120Vac, 60Hz (Adapter)	Jed Wu
RE<1G	A	30deg. C, 75%RH	120Vac, 60Hz (Adapter)	Ian Chang
PLC	A	25deg. C, 75%RH	120Vac, 60Hz (Adapter)	Starlitaly Wu
	B	25deg. C, 75%RH	120Vac, 60Hz (Notebook)	Starlitaly Wu
APCM	A	25deg. C, 76%RH	120Vac, 60Hz (Adapter)	Pirar Hsieh

### 3.3 Duty Cycle of Test Signal

Duty cycle of test signal is 100%, duty factor is not required.  
 Duty cycle of test signal is < 98%, duty factor shall be considered.

**802.11a:** Duty cycle of test signal is 100%.

**802.11ac (VHT20):** Duty cycle = 1.955 ms / 2.045 ms = 0.956, Duty factor =  $10 * \log(1/0.956) = 0.20$  dB

**802.11ac (VHT40):** Duty cycle = 0.972 ms / 1.065 ms = 0.913, Duty factor =  $10 * \log(1/0.913) = 0.40$  dB

**802.11ac (VHT80):** Duty cycle = 0.492 ms / 0.564 ms = 0.872, Duty factor =  $10 * \log(1/0.872) = 0.59$  dB



### 3.4 Description of Support Units

The EUT has been tested as an independent unit together with other necessary accessories or support units. The following support units or accessories were used to form a representative test configuration during the tests.

ID	Product	Brand	Model No.	Serial No.	FCC ID	Remarks
A.	Notebook PC	Lenove	81LG	PF1NF9V2	N/A	Provided by Lab
B.	Adapter	Apple	A1385	N/A	N/A	Provided by Lab
C.	Leather Sheath	Rakuten kobo	N/A	N/A	N/A	Supplied by applicant

ID	Cable Descriptions	Qty.	Length (m)	Shielding (Yes/No)	Cores (Qty.)	Remarks
1.	USB Type-C cable	1	1	Y	0	Supplied by applicant

#### 3.4.1 Configuration of System under Test

##### Mode A

Powered from Adapter with Leather Sheath

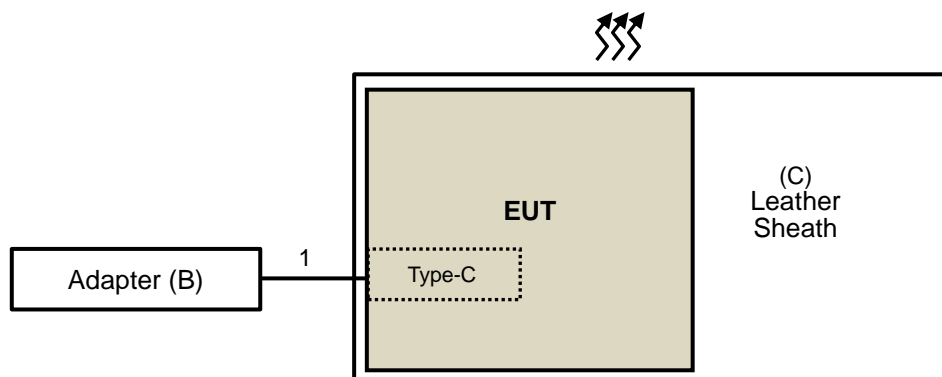

##### Mode B

Powered from Notebook with Leather Sheath

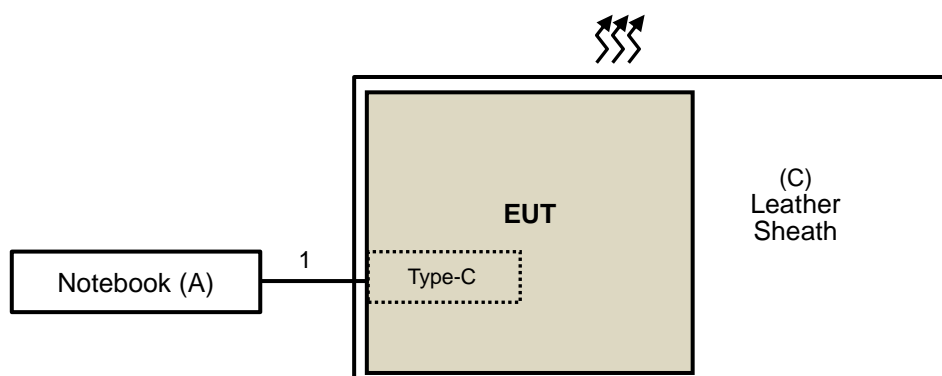

### 3.5 General Description of Applied Standard and References

The EUT is a RF Product. According to the specifications of the manufacturer, it must comply with the requirements of the following standards and references:

**Test standard:**

**FCC Part 15, Subpart E (15.407)**

**ANSI C63.10-2013**

All test items have been performed and recorded as per the above standards.

**References Test Guidance:**

**KDB 789033 D02 General UNII Test Procedure New Rules v02r01**

All test items have been performed as a reference to the above KDB test guidance.

## 4 Test Types and Results

### 4.1 Radiated Emission and Bandedge Measurement

#### 4.1.1 Limits of Radiated Emission and Bandedge Measurement

Radiated emissions which fall in the restricted bands must comply with the radiated emission limits specified as below table.

Frequencies (MHz)	Field Strength (microvolts/meter)	Measurement Distance (meters)
0.009 ~ 0.490	2400/F(kHz)	300
0.490 ~ 1.705	24000/F(kHz)	30
1.705 ~ 30.0	30	30
30 ~ 88	100	3
88 ~ 216	150	3
216 ~ 960	200	3
Above 960	500	3

#### NOTE:

- The lower limit shall apply at the transition frequencies.
- Emission level (dBuV/m) = 20 log Emission level (uV/m).
- For frequencies above 1000MHz, the field strength limits are based on average detector, however, the peak field strength of any emission shall not exceed the maximum permitted average limits, specified above by more than 20dB under any condition of modulation.

Limits of unwanted emission out of the restricted bands

Applicable To		Limit	
789033 D02 General UNII Test Procedure New Rules v02r01		Field Strength at 3m	
		PK:74 (dBµV/m)	AV:54 (dBµV/m)
Frequency Band	Applicable To	EIRP Limit	Equivalent Field Strength at 3m
5150~5250 MHz	15.407(b)(1)	PK:-27 (dBm/MHz)	PK:68.2(dBµV/m)
5250~5350 MHz	15.407(b)(2)		
5470~5725 MHz	15.407(b)(3)		
5725~5850 MHz	<input checked="" type="checkbox"/> 15.407(b)(4)(i)	PK:-27 (dBm/MHz) <sup>*1</sup> PK:10 (dBm/MHz) <sup>*2</sup> PK:15.6 (dBm/MHz) <sup>*3</sup> PK:27 (dBm/MHz) <sup>*4</sup>	PK: 68.2(dBµV/m) <sup>*1</sup> PK:105.2 (dBµV/m) <sup>*2</sup> PK: 110.8(dBµV/m) <sup>*3</sup> PK:122.2 (dBµV/m) <sup>*4</sup>
	<input type="checkbox"/> 15.407(b)(4)(ii)	Emission limits in section 15.247(d)	
<sup>*1</sup> beyond 75 MHz or more above of the band edge. <sup>*3</sup> below the band edge increasing linearly to a level of 15.6 dBm/MHz at 5 MHz above.		<sup>*2</sup> below the band edge increasing linearly to 10 dBm/MHz at 25 MHz above. <sup>*4</sup> from 5 MHz above or below the band edge increasing linearly to a level of 27 dBm/MHz at the band edge.	

#### Note:

The following formula is used to convert the equipment isotropic radiated power (eirp) to field strength:

$$E = \frac{1000000\sqrt{30P}}{3} \mu\text{V/m, where P is the eirp (Watts).}$$

#### 4.1.2 Test Instruments

Description & Manufacturer	Model no.	Serial No.	Calibrated Date	Calibrated Until
Test Receiver Agilent	N9038A	MY51210129	2021/3/12	2022/3/11
Software BVADT	ADT_Radiated_V8.7.08	NA	NA	NA
Software BVADT	ADT_RF Test Software V6.6.5.4	NA	NA	NA
Auto Control System(Antenna Tower, Table, Controller) ADT	SC100+AT100+TT100	0306	NA	NA
Pre_Amplifier EMCJ	EMC001340	980269	2021/6/29	2022/6/28
LOOP ANTENNA EMCJ	LPA600	270	2021/9/2	2023/9/1
RF Coaxial Cable Pacific	8D-FB	Cable-CH6-02	2021/7/13	2022/7/12
Pre_Amplifier HP	8447D	2432A03504	2021/2/18	2022/2/17
Bi-log Broadband Antenna Schwarzbeck	VULB9168	139	2020/11/6	2021/11/5
Attenuator Mini-Circuits	UNAT-5+	PAD-CH6-01	2021/7/13	2022/7/12
RF Coaxial Cable Pacific	8D-FB	Cable-CH6-02	2021/7/13	2022/7/12
Antenna(Horn) EMCO	3115	00028257	2020/11/22	2021/11/21
Test Receiver Agilent	N9038A	MY51210129	2021/3/12	2022/3/11
Pre-amplifier HP	8449B	3008A01201	2021/2/19	2022/2/18
RF Coaxial Cable NEAT BAR PROER SUHNER	SF-102	Cable-CH6-01	2021/7/8	2022/7/7
Highpass filter Wainwright Instruments	WHK 3.1/18G-10SS	SN 8	2021/5/28	2022/5/27
Fix tool for Boresight	BAF-01	5	NA	NA
Pre_Amplifier MITEQ	AMF-6F-260400-33-8P	892164	2021/2/19	2022/2/18
Antenna(Horn) Schwarzbeck	BBHA-9170	BBHA9170190	2020/11/22	2021/11/21
Spectrum Analyzer R&S	FSV40	101544	2021/5/24	2022/5/23
RF Coaxial Cable WOKEN	WC01	Cable-CH10-03	2021/7/8	2022/7/7
RF Coaxial Cable Rosnol	K1K50-UP0279-K1K50-3000	Cable-CH10(3m)-04	2021/7/8	2022/7/7
Highpass filter SUHNER	11SH10-7000/T18000-O/OP	SN 4	2021/5/28	2022/5/27

- NOTE:**
1. The calibration interval of the above test instruments is 12/24 months. And the calibrations are traceable to NML/ROC and NIST/USA.
  2. The horn antenna and HP preamplifier (model: 8449B) are used only for the measurement of emission frequency above 1GHz if tested.
  3. The test was performed in LK - 966 chamber 1.
  4. Tested Date: 2021/10/5 ~ 2021/10/7



#### 4.1.3 Test Procedure

##### **For Radiated emission below 30MHz**

- a. The EUT was placed on the top of a rotating table 0.8 meters above the ground at a 3 meter chamber room. The table was rotated 360 degrees to determine the position of the highest radiation.
- b. The EUT was set 3 meters away from the interference-receiving antenna, which was mounted on the top of a variable-height antenna tower.
- c. Parallel, perpendicular, and ground-parallel orientations of the antenna are set to make the measurement.
- d. For each suspected emission, the EUT was arranged to its worst case and the rotatable table was turned from 0 degrees to 360 degrees to find the maximum reading.
- e. The test-receiver system was set to Quasi-Peak Detect Function and Specified Bandwidth with Maximum Hold Mode.

##### **NOTE:**

1. The resolution bandwidth and video bandwidth of test receiver/spectrum analyzer is 9kHz at frequency below 30MHz.

##### **For Radiated emission above 30MHz**

- a. The EUT was placed on the top of a rotating table 0.8 meters (for 30MHz ~ 1GHz) / 1.5 meters (for above 1GHz) above the ground at 3 meter chamber room for test. The table was rotated 360 degrees to determine the position of the highest radiation.
- b. The EUT was set 3 meters away from the interference-receiving antenna, which was mounted on the top of a variable-height antenna tower.
- c. The height of antenna is varied from one meter to four meters above the ground to determine the maximum value of the field strength. Both horizontal and vertical polarizations of the antenna are set to make the measurement.
- d. For each suspected emission, the EUT was arranged to its worst case and then the antenna was tuned to heights from 1 meter to 4 meters and the rotatable table was turned from 0 degrees to 360 degrees to find the maximum reading.
- e. The test-receiver system was set to quasi-peak detect function and specified bandwidth with maximum hold mode when the test frequency is below 1 GHz.
- f. The test-receiver system was set to peak and average detects function and specified bandwidth with maximum hold mode when the test frequency is above 1 GHz. If the peak reading value also meets average limit, measurement with the average detector is unnecessary.

##### **Note:**

1. The resolution bandwidth and video bandwidth of test receiver/spectrum analyzer is 120kHz for Quasi-peak detection (QP) at frequency below 1GHz.
2. The resolution bandwidth of test receiver/spectrum analyzer is 1 MHz and the video bandwidth is 3 MHz for Peak detection (PK) at frequency above 1GHz.
3. The resolution bandwidth of test receiver/spectrum analyzer is 1MHz and the video bandwidth is  $\geq 1/T$  (Duty cycle < 98%) or 10Hz (Duty cycle  $\geq 98\%$ ) for Average detection (AV) at frequency above 1GHz.  
(802.11a: RBW = 1MHz, VBW = 10Hz; 802.11ac (VHT20): RBW = 1MHz, VBW = 560Hz;  
802.11ac (VHT40): RBW = 1MHz, VBW = 1.1kHz; 802.11ac (VHT80): RBW = 1MHz, VBW = 2.2kHz)
4. All modes of operation were investigated and the worst-case emissions are reported.

#### 4.1.4 Deviation from Test Standard

No deviation.

#### 4.1.5 Test Setup

##### For Radiated emission below 30MHz

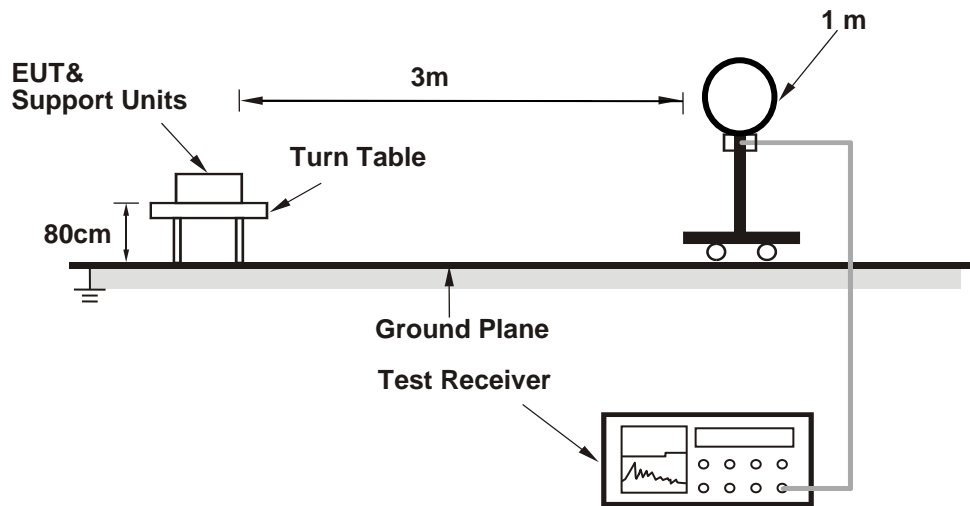

##### For Radiated emission 30MHz to 1GHz

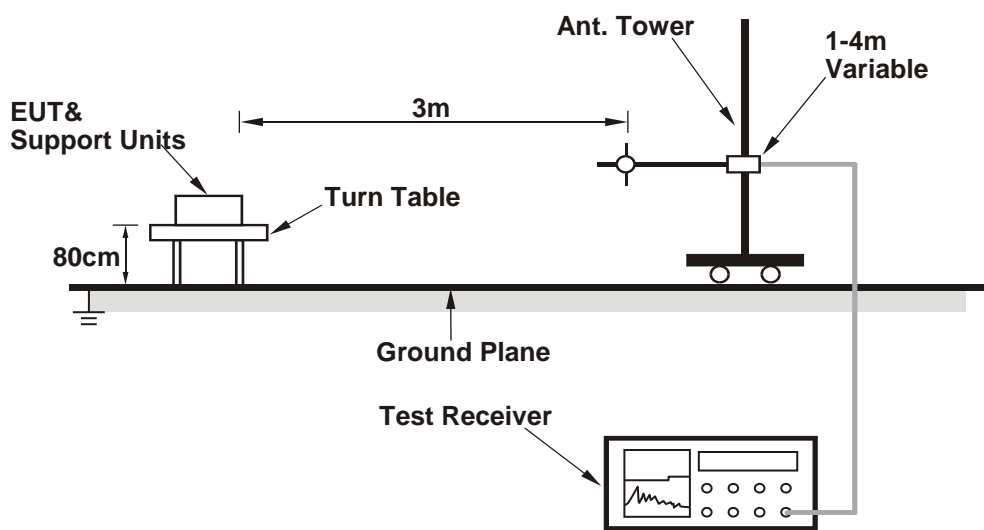

### For Radiated emission above 1GHz

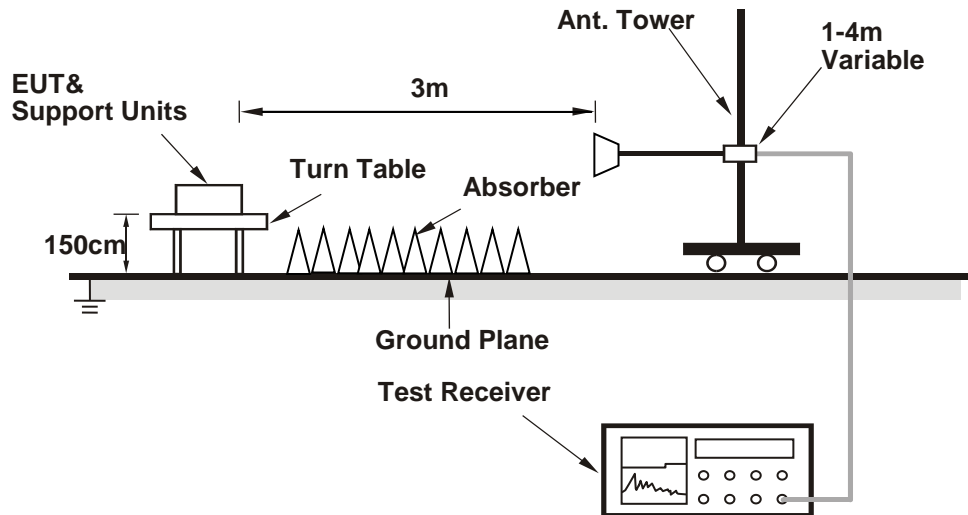

For the actual test configuration, please refer to the attached file (Test Setup Photo).

#### 4.1.6 EUT Operating Condition

- a. Connected the EUT to Adapter.
- b. Set the EUT under transmission condition continuously at specific channel frequency continuously.

4.1.7 Test Results

Mode A

ABOVE 1GHz DATA

<b>RF Mode</b>	TX 802.11a	<b>Channel</b>	CH 36 : 5180 MHz
<b>Frequency Range</b>	1GHz ~ 40GHz	<b>Detector Function</b>	Peak (PK) Average (AV)

Antenna Polarity & Test Distance : Horizontal at 3 m								
No	Frequency (MHz)	Emission Level (dBuV/m)	Limit (dBuV/m)	Margin (dB)	Antenna Height (m)	Table Angle (Degree)	Raw Value (dBuV)	Correction Factor (dB/m)
1	5150.00	69.35 PK	74.00	-4.65	2.80 H	296	62.54	6.81
2	5150.00	53.84 AV	54.00	-0.16	2.80 H	296	47.03	6.81
3	*5180.00	110.00 PK			2.80 H	296	102.97	7.03
4	*5180.00	102.88 AV			2.80 H	296	95.85	7.03
5	#10360.00	52.98 PK	68.20	-15.22	1.62 H	157	38.42	14.56
Antenna Polarity & Test Distance : Vertical at 3 m								
No	Frequency (MHz)	Emission Level (dBuV/m)	Limit (dBuV/m)	Margin (dB)	Antenna Height (m)	Table Angle (Degree)	Raw Value (dBuV)	Correction Factor (dB/m)
1	5150.00	67.37 PK	74.00	-6.63	2.80 V	56	60.56	6.81
2	5150.00	52.17 AV	54.00	-1.83	2.80 V	56	45.36	6.81
3	*5180.00	107.19 PK			2.80 V	56	100.16	7.03
4	*5180.00	100.03 AV			2.80 V	56	93.00	7.03
5	#10360.00	52.57 PK	68.20	-15.63	1.69 V	211	38.01	14.56

Remarks:

1. Emission Level(dBuV/m) = Raw Value(dBuV) + Correction Factor(dB/m)
2. Correction Factor(dB/m) = Antenna Factor(dB/m) + Cable Factor(dB) – Pre-Amplifier Factor(dB)
3. Margin value = Emission Level – Limit value
4. The other emission levels were very low against the limit.
5. " \* ": Fundamental frequency.
6. " # ": The radiated frequency is out of the restricted band.

<b>RF Mode</b>	TX 802.11a	<b>Channel</b>	CH 40 : 5200 MHz
<b>Frequency Range</b>	1GHz ~ 40GHz	<b>Detector Function</b>	Peak (PK) Average (AV)

**Antenna Polarity & Test Distance : Horizontal at 3 m**

No	Frequency (MHz)	Emission Level (dBuV/m)	Limit (dBuV/m)	Margin (dB)	Antenna Height (m)	Table Angle (Degree)	Raw Value (dBuV)	Correction Factor (dB/m)
1	5150.00	65.59 PK	74.00	-8.41	2.78 H	297	58.78	6.81
2	5150.00	53.14 AV	54.00	-0.86	2.78 H	297	46.33	6.81
3	*5200.00	114.39 PK			2.78 H	297	107.22	7.17
4	*5200.00	106.79 AV			2.78 H	297	99.62	7.17
5	#10400.00	53.52 PK	68.20	-14.68	1.64 H	152	38.90	14.62

**Antenna Polarity & Test Distance : Vertical at 3 m**

No	Frequency (MHz)	Emission Level (dBuV/m)	Limit (dBuV/m)	Margin (dB)	Antenna Height (m)	Table Angle (Degree)	Raw Value (dBuV)	Correction Factor (dB/m)
1	5150.00	61.53 PK	74.00	-12.47	2.54 V	115	54.72	6.81
2	5150.00	49.64 AV	54.00	-4.36	2.54 V	115	42.83	6.81
3	*5200.00	108.09 PK			2.54 V	115	100.92	7.17
4	*5200.00	100.55 AV			2.54 V	115	93.38	7.17
5	#10400.00	52.27 PK	68.20	-15.93	1.76 V	218	37.65	14.62

**Remarks:**

1. Emission Level(dBuV/m) = Raw Value(dBuV) + Correction Factor(dB/m)
2. Correction Factor(dB/m) = Antenna Factor(dB/m) + Cable Factor(dB) – Pre-Amplifier Factor(dB)
3. Margin value = Emission Level – Limit value
4. The other emission levels were very low against the limit.
5. " \* ": Fundamental frequency.
6. " # ": The radiated frequency is out of the restricted band.

<b>RF Mode</b>	TX 802.11a	<b>Channel</b>	CH 48 : 5240 MHz
<b>Frequency Range</b>	1GHz ~ 40GHz	<b>Detector Function</b>	Peak (PK) Average (AV)

**Antenna Polarity & Test Distance : Horizontal at 3 m**

No	Frequency (MHz)	Emission Level (dBuV/m)	Limit (dBuV/m)	Margin (dB)	Antenna Height (m)	Table Angle (Degree)	Raw Value (dBuV)	Correction Factor (dB/m)
1	*5240.00	115.41 PK			2.42 H	221	108.07	7.34
2	*5240.00	107.46 AV			2.42 H	221	100.12	7.34
3	5350.00	59.85 PK	74.00	-14.15	2.42 H	221	52.01	7.84
4	5350.00	47.73 AV	54.00	-6.27	2.42 H	221	39.89	7.84
5	#10480.00	53.79 PK	68.20	-14.41	1.58 H	142	38.76	15.03

**Antenna Polarity & Test Distance : Vertical at 3 m**

No	Frequency (MHz)	Emission Level (dBuV/m)	Limit (dBuV/m)	Margin (dB)	Antenna Height (m)	Table Angle (Degree)	Raw Value (dBuV)	Correction Factor (dB/m)
1	*5240.00	111.37 PK			1.04 V	152	104.03	7.34
2	*5240.00	103.70 AV			1.04 V	152	96.36	7.34
3	5350.00	58.39 PK	74.00	-15.61	1.04 V	152	50.55	7.84
4	5350.00	47.42 AV	54.00	-6.58	1.04 V	152	39.58	7.84
5	#10480.00	52.81 PK	68.20	-15.39	1.65 V	207	37.78	15.03

**Remarks:**

1. Emission Level(dBuV/m) = Raw Value(dBuV) + Correction Factor(dB/m)
2. Correction Factor(dB/m) = Antenna Factor(dB/m) + Cable Factor(dB) – Pre-Amplifier Factor(dB)
3. Margin value = Emission Level – Limit value
4. The other emission levels were very low against the limit.
5. " \* ": Fundamental frequency.
6. " # ": The radiated frequency is out of the restricted band.

<b>RF Mode</b>	TX 802.11a	<b>Channel</b>	CH 149 : 5745 MHz
<b>Frequency Range</b>	1GHz ~ 40GHz	<b>Detector Function</b>	Peak (PK) Average (AV)

**Antenna Polarity & Test Distance : Horizontal at 3 m**

No	Frequency (MHz)	Emission Level (dBuV/m)	Limit (dBuV/m)	Margin (dB)	Antenna Height (m)	Table Angle (Degree)	Raw Value (dBuV)	Correction Factor (dB/m)
1	#5640.25	60.58 PK	68.20	-7.62	3.24 H	298	53.30	7.28
2	*5745.00	115.36 PK			3.24 H	298	108.15	7.21
3	*5745.00	107.73 AV			3.24 H	298	100.52	7.21
4	#6013.60	58.69 PK	68.20	-9.51	3.24 H	298	51.10	7.59
5	11490.00	54.17 PK	74.00	-19.83	1.59 H	199	37.41	16.76
6	11490.00	43.52 AV	54.00	-10.48	1.59 H	199	26.76	16.76

**Antenna Polarity & Test Distance : Vertical at 3 m**

No	Frequency (MHz)	Emission Level (dBuV/m)	Limit (dBuV/m)	Margin (dB)	Antenna Height (m)	Table Angle (Degree)	Raw Value (dBuV)	Correction Factor (dB/m)
1	#5647.55	60.84 PK	68.20	-7.36	3.37 V	28	53.58	7.26
2	*5745.00	117.17 PK			3.37 V	28	109.96	7.21
3	*5745.00	109.48 AV			3.37 V	28	102.27	7.21
4	#6006.42	58.24 PK	68.20	-9.96	3.37 V	28	50.66	7.58
5	11490.00	54.92 PK	74.00	-19.08	1.54 V	217	38.16	16.76
6	11490.00	44.37 AV	54.00	-9.63	1.54 V	217	27.61	16.76

**Remarks:**

1. Emission Level(dBuV/m) = Raw Value(dBuV) + Correction Factor(dB/m)
2. Correction Factor(dB/m) = Antenna Factor(dB/m) + Cable Factor(dB) – Pre-Amplifier Factor(dB)
3. Margin value = Emission Level – Limit value
4. The other emission levels were very low against the limit.
5. " \* ": Fundamental frequency.
6. " # ": The radiated frequency is out of the restricted band.

<b>RF Mode</b>	TX 802.11a	<b>Channel</b>	CH 157 : 5785 MHz
<b>Frequency Range</b>	1GHz ~ 40GHz	<b>Detector Function</b>	Peak (PK) Average (AV)

**Antenna Polarity & Test Distance : Horizontal at 3 m**

No	Frequency (MHz)	Emission Level (dBuV/m)	Limit (dBuV/m)	Margin (dB)	Antenna Height (m)	Table Angle (Degree)	Raw Value (dBuV)	Correction Factor (dB/m)
1	#5596.55	58.24 PK	68.20	-9.96	1.28 H	235	50.80	7.44
2	*5785.00	114.98 PK			1.28 H	235	107.70	7.28
3	*5785.00	107.45 AV			1.28 H	235	100.17	7.28
4	#6007.43	59.65 PK	68.20	-8.55	1.28 H	235	52.07	7.58
5	11570.00	54.55 PK	74.00	-19.45	1.64 H	201	37.56	16.99
6	11570.00	43.88 AV	54.00	-10.12	1.64 H	201	26.89	16.99

**Antenna Polarity & Test Distance : Vertical at 3 m**

No	Frequency (MHz)	Emission Level (dBuV/m)	Limit (dBuV/m)	Margin (dB)	Antenna Height (m)	Table Angle (Degree)	Raw Value (dBuV)	Correction Factor (dB/m)
1	#5642.62	58.26 PK	68.20	-9.94	3.34 V	29	50.99	7.27
2	*5785.00	118.09 PK			3.34 V	29	110.81	7.28
3	*5785.00	110.53 AV			3.34 V	29	103.25	7.28
4	#5935.23	59.43 PK	68.20	-8.77	3.34 V	29	52.08	7.35
5	11570.00	55.20 PK	74.00	-18.80	1.59 V	215	38.21	16.99
6	11570.00	44.74 AV	54.00	-9.26	1.59 V	215	27.75	16.99

**Remarks:**

1. Emission Level(dBuV/m) = Raw Value(dBuV) + Correction Factor(dB/m)
2. Correction Factor(dB/m) = Antenna Factor(dB/m) + Cable Factor(dB) – Pre-Amplifier Factor(dB)
3. Margin value = Emission Level – Limit value
4. The other emission levels were very low against the limit.
5. " \* ": Fundamental frequency.
6. " # ": The radiated frequency is out of the restricted band.



<b>RF Mode</b>	TX 802.11a	<b>Channel</b>	CH 165 : 5825 MHz
<b>Frequency Range</b>	1GHz ~ 40GHz	<b>Detector Function</b>	Peak (PK) Average (AV)

**Antenna Polarity & Test Distance : Horizontal at 3 m**

No	Frequency (MHz)	Emission Level (dBuV/m)	Limit (dBuV/m)	Margin (dB)	Antenna Height (m)	Table Angle (Degree)	Raw Value (dBuV)	Correction Factor (dB/m)
1	#5590.85	58.13 PK	68.20	-10.07	1.27 H	234	50.66	7.47
2	*5825.00	115.62 PK			1.27 H	234	108.34	7.28
3	*5825.00	107.91 AV			1.27 H	234	100.63	7.28
4	#5987.95	59.42 PK	68.20	-8.78	1.27 H	234	51.87	7.55
5	11650.00	55.69 PK	74.00	-18.31	1.63 H	202	38.45	17.24
6	11650.00	44.96 AV	54.00	-9.04	1.63 H	202	27.72	17.24

**Antenna Polarity & Test Distance : Vertical at 3 m**

No	Frequency (MHz)	Emission Level (dBuV/m)	Limit (dBuV/m)	Margin (dB)	Antenna Height (m)	Table Angle (Degree)	Raw Value (dBuV)	Correction Factor (dB/m)
1	#5573.75	58.02 PK	68.20	-10.18	3.28 V	31	50.44	7.58
2	*5825.00	118.73 PK			3.28 V	31	111.45	7.28
3	*5825.00	111.05 AV			3.28 V	31	103.77	7.28
4	#5968.95	59.35 PK	68.20	-8.85	3.28 V	31	51.87	7.48
5	11650.00	56.00 PK	74.00	-18.00	1.55 V	226	38.76	17.24
6	11650.00	45.35 AV	54.00	-8.65	1.55 V	226	28.11	17.24

**Remarks:**

1. Emission Level(dBuV/m) = Raw Value(dBuV) + Correction Factor(dB/m)
2. Correction Factor(dB/m) = Antenna Factor(dB/m) + Cable Factor(dB) – Pre-Amplifier Factor(dB)
3. Margin value = Emission Level – Limit value
4. The other emission levels were very low against the limit.
5. " \* ": Fundamental frequency.
6. " # ": The radiated frequency is out of the restricted band.

<b>RF Mode</b>	TX 802.11ac (VHT20)	<b>Channel</b>	CH 36 : 5180 MHz
<b>Frequency Range</b>	1GHz ~ 40GHz	<b>Detector Function</b>	Peak (PK) Average (AV)

**Antenna Polarity & Test Distance : Horizontal at 3 m**

No	Frequency (MHz)	Emission Level (dBuV/m)	Limit (dBuV/m)	Margin (dB)	Antenna Height (m)	Table Angle (Degree)	Raw Value (dBuV)	Correction Factor (dB/m)
1	5150.00	68.28 PK	74.00	-5.72	2.79 H	296	61.47	6.81
2	5150.00	53.67 AV	54.00	-0.33	2.79 H	296	46.86	6.81
3	*5180.00	110.93 PK			2.79 H	296	103.90	7.03
4	*5180.00	102.52 AV			2.79 H	296	95.49	7.03
5	#10360.00	52.82 PK	68.20	-15.38	1.66 H	159	38.26	14.56

**Antenna Polarity & Test Distance : Vertical at 3 m**

No	Frequency (MHz)	Emission Level (dBuV/m)	Limit (dBuV/m)	Margin (dB)	Antenna Height (m)	Table Angle (Degree)	Raw Value (dBuV)	Correction Factor (dB/m)
1	5150.00	67.45 PK	74.00	-6.55	3.07 V	55	60.64	6.81
2	5150.00	52.27 AV	54.00	-1.73	3.07 V	55	45.46	6.81
3	*5180.00	108.53 PK			3.07 V	55	101.50	7.03
4	*5180.00	100.70 AV			3.07 V	55	93.67	7.03
5	#10360.00	52.82 PK	68.20	-15.38	1.72 V	206	38.26	14.56

**Remarks:**

1. Emission Level(dBuV/m) = Raw Value(dBuV) + Correction Factor(dB/m)
2. Correction Factor(dB/m) = Antenna Factor(dB/m) + Cable Factor(dB) – Pre-Amplifier Factor(dB)
3. Margin value = Emission Level – Limit value
4. The other emission levels were very low against the limit.
5. " \* " : Fundamental frequency.
6. " # " : The radiated frequency is out of the restricted band.

<b>RF Mode</b>	TX 802.11ac (VHT20)	<b>Channel</b>	CH 40 : 5200 MHz
<b>Frequency Range</b>	1GHz ~ 40GHz	<b>Detector Function</b>	Peak (PK) Average (AV)

**Antenna Polarity & Test Distance : Horizontal at 3 m**

No	Frequency (MHz)	Emission Level (dBuV/m)	Limit (dBuV/m)	Margin (dB)	Antenna Height (m)	Table Angle (Degree)	Raw Value (dBuV)	Correction Factor (dB/m)
1	5150.00	68.26 PK	74.00	-5.74	3.06 H	295	61.45	6.81
2	5150.00	53.81 AV	54.00	-0.19	3.06 H	295	47.00	6.81
3	*5200.00	115.00 PK			3.06 H	295	107.83	7.17
4	*5200.00	106.93 AV			3.06 H	295	99.76	7.17
5	#10400.00	52.98 PK	68.20	-15.22	1.79 H	217	38.36	14.62

**Antenna Polarity & Test Distance : Vertical at 3 m**

No	Frequency (MHz)	Emission Level (dBuV/m)	Limit (dBuV/m)	Margin (dB)	Antenna Height (m)	Table Angle (Degree)	Raw Value (dBuV)	Correction Factor (dB/m)
1	5150.00	65.17 PK	74.00	-8.83	2.54 V	115	58.36	6.81
2	5150.00	50.43 AV	54.00	-3.57	2.54 V	115	43.62	6.81
3	*5200.00	108.92 PK			2.54 V	115	101.75	7.17
4	*5200.00	100.88 AV			2.54 V	115	93.71	7.17
5	#10400.00	52.38 PK	68.20	-15.82	1.73 V	212	37.76	14.62

**Remarks:**

1. Emission Level(dBuV/m) = Raw Value(dBuV) + Correction Factor(dB/m)
2. Correction Factor(dB/m) = Antenna Factor(dB/m) + Cable Factor(dB) – Pre-Amplifier Factor(dB)
3. Margin value = Emission Level – Limit value
4. The other emission levels were very low against the limit.
5. " \* " : Fundamental frequency.
6. " # " : The radiated frequency is out of the restricted band.

<b>RF Mode</b>	TX 802.11ac (VHT20)	<b>Channel</b>	CH 48 : 5240 MHz
<b>Frequency Range</b>	1GHz ~ 40GHz	<b>Detector Function</b>	Peak (PK) Average (AV)

**Antenna Polarity & Test Distance : Horizontal at 3 m**

No	Frequency (MHz)	Emission Level (dBuV/m)	Limit (dBuV/m)	Margin (dB)	Antenna Height (m)	Table Angle (Degree)	Raw Value (dBuV)	Correction Factor (dB/m)
1	*5240.00	116.46 PK			3.17 H	288	109.12	7.34
2	*5240.00	108.37 AV			3.17 H	288	101.03	7.34
3	5350.00	62.03 PK	74.00	-11.97	3.17 H	288	54.19	7.84
4	5350.00	48.45 AV	54.00	-5.55	3.17 H	288	40.61	7.84
5	#10480.00	53.20 PK	68.20	-15.00	1.72 H	214	38.17	15.03

**Antenna Polarity & Test Distance : Vertical at 3 m**

No	Frequency (MHz)	Emission Level (dBuV/m)	Limit (dBuV/m)	Margin (dB)	Antenna Height (m)	Table Angle (Degree)	Raw Value (dBuV)	Correction Factor (dB/m)
1	*5240.00	109.54 PK			1.03 V	183	102.20	7.34
2	*5240.00	101.69 AV			1.03 V	183	94.35	7.34
3	5350.00	59.11 PK	74.00	-14.89	1.03 V	183	51.27	7.84
4	5350.00	47.87 AV	54.00	-6.13	1.03 V	183	40.03	7.84
5	#10480.00	52.48 PK	68.20	-15.72	1.68 V	213	37.45	15.03

**Remarks:**

1. Emission Level(dBuV/m) = Raw Value(dBuV) + Correction Factor(dB/m)
2. Correction Factor(dB/m) = Antenna Factor(dB/m) + Cable Factor(dB) – Pre-Amplifier Factor(dB)
3. Margin value = Emission Level – Limit value
4. The other emission levels were very low against the limit.
5. " \* " : Fundamental frequency.
6. " # " : The radiated frequency is out of the restricted band.

<b>RF Mode</b>	TX 802.11ac (VHT20)	<b>Channel</b>	CH 149 : 5745 MHz
<b>Frequency Range</b>	1GHz ~ 40GHz	<b>Detector Function</b>	Peak (PK) Average (AV)

Antenna Polarity & Test Distance : Horizontal at 3 m								
No	Frequency (MHz)	Emission Level (dBuV/m)	Limit (dBuV/m)	Margin (dB)	Antenna Height (m)	Table Angle (Degree)	Raw Value (dBuV)	Correction Factor (dB/m)
1	#5647.37	61.53 PK	68.20	-6.67	2.80 H	294	54.27	7.26
2	*5745.00	116.74 PK			2.80 H	294	109.53	7.21
3	*5745.00	108.40 AV			2.80 H	294	101.19	7.21
4	#5970.37	58.66 PK	68.20	-9.54	2.80 H	294	51.18	7.48
5	11490.00	54.33 PK	74.00	-19.67	1.51 H	202	37.57	16.76
6	11490.00	43.64 AV	54.00	-10.36	1.51 H	202	26.88	16.76
Antenna Polarity & Test Distance : Vertical at 3 m								
No	Frequency (MHz)	Emission Level (dBuV/m)	Limit (dBuV/m)	Margin (dB)	Antenna Height (m)	Table Angle (Degree)	Raw Value (dBuV)	Correction Factor (dB/m)
1	#5648.32	61.26 PK	68.20	-6.94	2.71 V	1	54.00	7.26
2	*5745.00	118.07 PK			2.71 V	1	110.86	7.21
3	*5745.00	109.72 AV			2.71 V	1	102.51	7.21
4	#6004.10	58.98 PK	68.20	-9.22	2.71 V	1	51.40	7.58
5	11490.00	55.09 PK	74.00	-18.91	1.66 V	225	38.33	16.76
6	11490.00	44.62 AV	54.00	-9.38	1.66 V	225	27.86	16.76

**Remarks:**

1. Emission Level(dBuV/m) = Raw Value(dBuV) + Correction Factor(dB/m)
2. Correction Factor(dB/m) = Antenna Factor(dB/m) + Cable Factor(dB) – Pre-Amplifier Factor(dB)
3. Margin value = Emission Level – Limit value
4. The other emission levels were very low against the limit.
5. " \* ": Fundamental frequency.
6. " # ": The radiated frequency is out of the restricted band.

<b>RF Mode</b>	TX 802.11ac (VHT20)	<b>Channel</b>	CH 157 : 5785 MHz
<b>Frequency Range</b>	1GHz ~ 40GHz	<b>Detector Function</b>	Peak (PK) Average (AV)

Antenna Polarity & Test Distance : Horizontal at 3 m								
No	Frequency (MHz)	Emission Level (dBuV/m)	Limit (dBuV/m)	Margin (dB)	Antenna Height (m)	Table Angle (Degree)	Raw Value (dBuV)	Correction Factor (dB/m)
1	#5636.93	57.95 PK	68.20	-10.25	1.49 H	234	50.67	7.28
2	*5785.00	114.73 PK			1.49 H	234	107.45	7.28
3	*5785.00	106.36 AV			1.49 H	234	99.08	7.28
4	#5949.48	59.28 PK	68.20	-8.92	1.49 H	234	51.86	7.42
5	11570.00	54.40 PK	74.00	-19.60	1.68 H	214	37.41	16.99
6	11570.00	43.64 AV	54.00	-10.36	1.68 H	214	26.65	16.99
Antenna Polarity & Test Distance : Vertical at 3 m								
No	Frequency (MHz)	Emission Level (dBuV/m)	Limit (dBuV/m)	Margin (dB)	Antenna Height (m)	Table Angle (Degree)	Raw Value (dBuV)	Correction Factor (dB/m)
1	#5624.10	58.22 PK	68.20	-9.98	2.80 V	4	50.89	7.33
2	*5785.00	118.31 PK			2.80 V	4	111.03	7.28
3	*5785.00	110.03 AV			2.80 V	4	102.75	7.28
4	#6007.90	59.27 PK	68.20	-8.93	2.80 V	4	51.69	7.58
5	11570.00	55.28 PK	74.00	-18.72	1.64 V	217	38.29	16.99
6	11570.00	44.81 AV	54.00	-9.19	1.64 V	217	27.82	16.99

**Remarks:**

1. Emission Level(dBuV/m) = Raw Value(dBuV) + Correction Factor(dB/m)
2. Correction Factor(dB/m) = Antenna Factor(dB/m) + Cable Factor(dB) – Pre-Amplifier Factor(dB)
3. Margin value = Emission Level – Limit value
4. The other emission levels were very low against the limit.
5. " \* ": Fundamental frequency.
6. " # ": The radiated frequency is out of the restricted band.

<b>RF Mode</b>	TX 802.11ac (VHT20)	<b>Channel</b>	CH 165 : 5825 MHz
<b>Frequency Range</b>	1GHz ~ 40GHz	<b>Detector Function</b>	Peak (PK) Average (AV)

**Antenna Polarity & Test Distance : Horizontal at 3 m**

No	Frequency (MHz)	Emission Level (dBuV/m)	Limit (dBuV/m)	Margin (dB)	Antenna Height (m)	Table Angle (Degree)	Raw Value (dBuV)	Correction Factor (dB/m)
1	#5617.45	58.78 PK	68.20	-9.42	2.99 H	291	51.43	7.35
2	*5825.00	115.94 PK			2.99 H	291	108.66	7.28
3	*5825.00	107.79 AV			2.99 H	291	100.51	7.28
4	#5930.95	60.26 PK	68.20	-7.94	2.99 H	291	52.93	7.33
5	11650.00	54.88 PK	74.00	-19.12	1.68 H	205	37.64	17.24
6	11650.00	44.16 AV	54.00	-9.84	1.68 H	205	26.92	17.24

**Antenna Polarity & Test Distance : Vertical at 3 m**

No	Frequency (MHz)	Emission Level (dBuV/m)	Limit (dBuV/m)	Margin (dB)	Antenna Height (m)	Table Angle (Degree)	Raw Value (dBuV)	Correction Factor (dB/m)
1	#5571.37	58.00 PK	68.20	-10.20	2.89 V	4	50.41	7.59
2	*5825.00	119.01 PK			2.89 V	4	111.73	7.28
3	*5825.00	110.62 AV			2.89 V	4	103.34	7.28
4	#5927.62	59.69 PK	68.20	-8.51	2.89 V	4	52.38	7.31
5	11650.00	55.76 PK	74.00	-18.24	1.51 V	218	38.52	17.24
6	11650.00	45.19 AV	54.00	-8.81	1.51 V	218	27.95	17.24

**Remarks:**

1. Emission Level(dBuV/m) = Raw Value(dBuV) + Correction Factor(dB/m)
2. Correction Factor(dB/m) = Antenna Factor(dB/m) + Cable Factor(dB) – Pre-Amplifier Factor(dB)
3. Margin value = Emission Level – Limit value
4. The other emission levels were very low against the limit.
5. " \* ": Fundamental frequency.
6. " # ": The radiated frequency is out of the restricted band.

<b>RF Mode</b>	TX 802.11ac (VHT40)	<b>Channel</b>	CH 38 : 5190 MHz
<b>Frequency Range</b>	1GHz ~ 40GHz	<b>Detector Function</b>	Peak (PK) Average (AV)

**Antenna Polarity & Test Distance : Horizontal at 3 m**

No	Frequency (MHz)	Emission Level (dBuV/m)	Limit (dBuV/m)	Margin (dB)	Antenna Height (m)	Table Angle (Degree)	Raw Value (dBuV)	Correction Factor (dB/m)
1	5150.00	66.49 PK	74.00	-7.51	3.23 H	295	59.68	6.81
2	5150.00	53.47 AV	54.00	-0.53	3.23 H	295	46.66	6.81
3	*5190.00	105.25 PK			3.23 H	295	98.14	7.11
4	*5190.00	97.28 AV			3.23 H	295	90.17	7.11
5	#10380.00	52.87 PK	68.20	-15.33	1.76 H	219	38.28	14.59

**Antenna Polarity & Test Distance : Vertical at 3 m**

No	Frequency (MHz)	Emission Level (dBuV/m)	Limit (dBuV/m)	Margin (dB)	Antenna Height (m)	Table Angle (Degree)	Raw Value (dBuV)	Correction Factor (dB/m)
1	5150.00	59.95 PK	74.00	-14.05	3.36 V	177	53.14	6.81
2	5150.00	48.38 AV	54.00	-5.62	3.36 V	177	41.57	6.81
3	*5190.00	98.39 PK			3.36 V	177	91.28	7.11
4	*5190.00	90.56 AV			3.36 V	177	83.45	7.11
5	#10380.00	51.97 PK	68.20	-16.23	1.75 V	226	37.38	14.59

**Remarks:**

1. Emission Level(dBuV/m) = Raw Value(dBuV) + Correction Factor(dB/m)
2. Correction Factor(dB/m) = Antenna Factor(dB/m) + Cable Factor(dB) – Pre-Amplifier Factor(dB)
3. Margin value = Emission Level – Limit value
4. The other emission levels were very low against the limit.
5. " \* " : Fundamental frequency.
6. " # " : The radiated frequency is out of the restricted band.



<b>RF Mode</b>	TX 802.11ac (VHT40)	<b>Channel</b>	CH 46 : 5230 MHz
<b>Frequency Range</b>	1GHz ~ 40GHz	<b>Detector Function</b>	Peak (PK) Average (AV)

**Antenna Polarity & Test Distance : Horizontal at 3 m**

No	Frequency (MHz)	Emission Level (dBuV/m)	Limit (dBuV/m)	Margin (dB)	Antenna Height (m)	Table Angle (Degree)	Raw Value (dBuV)	Correction Factor (dB/m)
1	5150.00	66.95 PK	74.00	-7.05	2.22 H	221	60.14	6.81
2	5150.00	52.23 AV	54.00	-1.77	2.22 H	221	45.42	6.81
3	*5230.00	110.61 PK			2.22 H	221	103.31	7.30
4	*5230.00	102.78 AV			2.22 H	221	95.48	7.30
5	5350.00	60.47 PK	74.00	-13.53	2.22 H	221	52.63	7.84
6	5350.00	49.20 AV	54.00	-4.80	2.22 H	221	41.36	7.84
7	#10460.00	53.27 PK	68.20	-14.93	1.81 H	234	38.34	14.93

**Antenna Polarity & Test Distance : Vertical at 3 m**

No	Frequency (MHz)	Emission Level (dBuV/m)	Limit (dBuV/m)	Margin (dB)	Antenna Height (m)	Table Angle (Degree)	Raw Value (dBuV)	Correction Factor (dB/m)
1	5150.00	63.77 PK	74.00	-10.23	1.11 V	156	56.96	6.81
2	5150.00	50.19 AV	54.00	-3.81	1.11 V	156	43.38	6.81
3	*5230.00	108.48 PK			1.11 V	156	101.18	7.30
4	*5230.00	100.22 AV			1.11 V	156	92.92	7.30
5	5350.00	60.85 PK	74.00	-13.15	1.11 V	156	53.01	7.84
6	5350.00	48.80 AV	54.00	-5.20	1.11 V	156	40.96	7.84
7	#10460.00	52.39 PK	68.20	-15.81	1.58 V	204	37.46	14.93

**Remarks:**

1. Emission Level(dBuV/m) = Raw Value(dBuV) + Correction Factor(dB/m)
2. Correction Factor(dB/m) = Antenna Factor(dB/m) + Cable Factor(dB) – Pre-Amplifier Factor(dB)
3. Margin value = Emission Level – Limit value
4. The other emission levels were very low against the limit.
5. " \* ": Fundamental frequency.
6. " # ": The radiated frequency is out of the restricted band.

<b>RF Mode</b>	TX 802.11ac (VHT40)	<b>Channel</b>	CH 151 : 5755 MHz
<b>Frequency Range</b>	1GHz ~ 40GHz	<b>Detector Function</b>	Peak (PK) Average (AV)

**Antenna Polarity & Test Distance : Horizontal at 3 m**

No	Frequency (MHz)	Emission Level (dBuV/m)	Limit (dBuV/m)	Margin (dB)	Antenna Height (m)	Table Angle (Degree)	Raw Value (dBuV)	Correction Factor (dB/m)
1	#5650.70	66.53 PK	68.20	-1.67	1.50 H	234	59.29	7.24
2	*5755.00	111.20 PK			1.50 H	234	103.98	7.22
3	*5755.00	103.58 AV			1.50 H	234	96.36	7.22
4	#5994.12	58.99 PK	68.20	-9.21	1.50 H	234	51.44	7.55
5	11510.00	53.87 PK	74.00	-20.13	1.60 H	221	37.06	16.81
6	11510.00	43.23 AV	54.00	-10.77	1.60 H	221	26.42	16.81

**Antenna Polarity & Test Distance : Vertical at 3 m**

No	Frequency (MHz)	Emission Level (dBuV/m)	Limit (dBuV/m)	Margin (dB)	Antenna Height (m)	Table Angle (Degree)	Raw Value (dBuV)	Correction Factor (dB/m)
1	#5638.82	68.01 PK	68.20	-0.19	2.83 V	4	60.73	7.28
2	*5755.00	114.84 PK			2.83 V	4	107.62	7.22
3	*5755.00	106.59 AV			2.83 V	4	99.37	7.22
4	#5927.15	61.08 PK	68.20	-7.12	2.83 V	4	53.77	7.31
5	11510.00	54.67 PK	74.00	-19.33	1.52 V	213	37.86	16.81
6	11510.00	43.92 AV	54.00	-10.08	1.52 V	213	27.11	16.81

**Remarks:**

1. Emission Level(dBuV/m) = Raw Value(dBuV) + Correction Factor(dB/m)
2. Correction Factor(dB/m) = Antenna Factor(dB/m) + Cable Factor(dB) – Pre-Amplifier Factor(dB)
3. Margin value = Emission Level – Limit value
4. The other emission levels were very low against the limit.
5. " \* ": Fundamental frequency.
6. " # ": The radiated frequency is out of the restricted band.

<b>RF Mode</b>	TX 802.11ac (VHT40)	<b>Channel</b>	CH 159 : 5795 MHz
<b>Frequency Range</b>	1GHz ~ 40GHz	<b>Detector Function</b>	Peak (PK) Average (AV)

Antenna Polarity & Test Distance : Horizontal at 3 m								
No	Frequency (MHz)	Emission Level (dBuV/m)	Limit (dBuV/m)	Margin (dB)	Antenna Height (m)	Table Angle (Degree)	Raw Value (dBuV)	Correction Factor (dB/m)
1	#5637.87	61.02 PK	68.20	-7.18	1.28 H	235	53.73	7.29
2	*5795.00	112.16 PK			1.28 H	235	104.86	7.30
3	*5795.00	103.90 AV			1.28 H	235	96.60	7.30
4	#5932.37	62.38 PK	68.20	-5.82	1.28 H	235	55.05	7.33
5	11590.00	54.45 PK	74.00	-19.55	1.59 H	220	37.41	17.04
6	11590.00	43.76 AV	54.00	-10.24	1.59 H	220	26.72	17.04
Antenna Polarity & Test Distance : Vertical at 3 m								
No	Frequency (MHz)	Emission Level (dBuV/m)	Limit (dBuV/m)	Margin (dB)	Antenna Height (m)	Table Angle (Degree)	Raw Value (dBuV)	Correction Factor (dB/m)
1	#5652.12	65.22 PK	68.20	-2.98	2.91 V	5	57.98	7.24
2	*5795.00	114.98 PK			2.91 V	5	107.68	7.30
3	*5795.00	106.98 AV			2.91 V	5	99.68	7.30
4	#5926.20	68.00 PK	68.20	-0.20	2.91 V	5	60.70	7.30
5	11590.00	55.16 PK	74.00	-18.84	1.63 V	211	38.12	17.04
6	11590.00	44.92 AV	54.00	-9.08	1.63 V	211	27.88	17.04

**Remarks:**

1. Emission Level(dBuV/m) = Raw Value(dBuV) + Correction Factor(dB/m)
2. Correction Factor(dB/m) = Antenna Factor(dB/m) + Cable Factor(dB) – Pre-Amplifier Factor(dB)
3. Margin value = Emission Level – Limit value
4. The other emission levels were very low against the limit.
5. " \* " : Fundamental frequency.
6. " # " : The radiated frequency is out of the restricted band.

<b>RF Mode</b>	TX 802.11ac (VHT80)	<b>Channel</b>	CH 42 : 5210 MHz
<b>Frequency Range</b>	1GHz ~ 40GHz	<b>Detector Function</b>	Peak (PK) Average (AV)

**Antenna Polarity & Test Distance : Horizontal at 3 m**

No	Frequency (MHz)	Emission Level (dBuV/m)	Limit (dBuV/m)	Margin (dB)	Antenna Height (m)	Table Angle (Degree)	Raw Value (dBuV)	Correction Factor (dB/m)
1	5150.00	63.94 PK	74.00	-10.06	3.06 H	303	57.13	6.81
2	5150.00	53.22 AV	54.00	-0.78	3.06 H	303	46.41	6.81
3	*5210.00	100.68 PK			3.06 H	303	93.47	7.21
4	*5210.00	92.31 AV			3.06 H	303	85.10	7.21
5	5350.00	59.70 PK	74.00	-14.30	3.06 H	303	51.86	7.84
6	5350.00	49.13 AV	54.00	-4.87	3.06 H	303	41.29	7.84
7	#10420.00	53.13 PK	68.20	-15.07	1.78 H	229	38.41	14.72

**Antenna Polarity & Test Distance : Vertical at 3 m**

No	Frequency (MHz)	Emission Level (dBuV/m)	Limit (dBuV/m)	Margin (dB)	Antenna Height (m)	Table Angle (Degree)	Raw Value (dBuV)	Correction Factor (dB/m)
1	5150.00	64.24 PK	74.00	-9.76	1.12 V	176	57.43	6.81
2	5150.00	52.32 AV	54.00	-1.68	1.12 V	176	45.51	6.81
3	*5210.00	96.92 PK			1.12 V	176	89.71	7.21
4	*5210.00	88.69 AV			1.12 V	176	81.48	7.21
5	5450.00	59.46 PK	74.00	-14.54	1.12 V	176	51.53	7.93
6	5450.00	48.64 AV	54.00	-5.36	1.12 V	176	40.71	7.93
7	#10420.00	51.87 PK	68.20	-16.33	1.63 V	211	37.15	14.72

**Remarks:**

1. Emission Level(dBuV/m) = Raw Value(dBuV) + Correction Factor(dB/m)
2. Correction Factor(dB/m) = Antenna Factor(dB/m) + Cable Factor(dB) – Pre-Amplifier Factor(dB)
3. Margin value = Emission Level – Limit value
4. The other emission levels were very low against the limit.
5. " \* ": Fundamental frequency.
6. " # ": The radiated frequency is out of the restricted band.

<b>RF Mode</b>	TX 802.11ac (VHT80)	<b>Channel</b>	CH 155 : 5775 MHz
<b>Frequency Range</b>	1GHz ~ 40GHz	<b>Detector Function</b>	Peak (PK) Average (AV)

**Antenna Polarity & Test Distance : Horizontal at 3 m**

No	Frequency (MHz)	Emission Level (dBuV/m)	Limit (dBuV/m)	Margin (dB)	Antenna Height (m)	Table Angle (Degree)	Raw Value (dBuV)	Correction Factor (dB/m)
1	#5644.05	66.57 PK	68.20	-1.63	2.78 H	294	59.31	7.26
2	*5775.00	108.31 PK			2.78 H	294	101.05	7.26
3	*5775.00	100.25 AV			2.78 H	294	92.99	7.26
4	#5929.05	63.63 PK	68.20	-4.57	2.78 H	294	56.32	7.31
5	11550.00	53.77 PK	74.00	-20.23	1.57 H	204	36.85	16.92
6	11550.00	43.07 AV	54.00	-10.93	1.57 H	204	26.15	16.92

**Antenna Polarity & Test Distance : Vertical at 3 m**

No	Frequency (MHz)	Emission Level (dBuV/m)	Limit (dBuV/m)	Margin (dB)	Antenna Height (m)	Table Angle (Degree)	Raw Value (dBuV)	Correction Factor (dB/m)
1	#5644.05	65.52 PK	68.20	-2.68	2.82 V	6	58.26	7.26
2	*5775.00	111.32 PK			2.82 V	6	104.06	7.26
3	*5775.00	102.76 AV			2.82 V	6	95.50	7.26
4	#5924.77	67.35 PK	68.20	-0.85	2.82 V	6	60.06	7.29
5	11550.00	54.28 PK	74.00	-19.72	1.72 V	208	37.36	16.92
6	11550.00	43.67 AV	54.00	-10.33	1.72 V	208	26.75	16.92

**Remarks:**

1. Emission Level(dBuV/m) = Raw Value(dBuV) + Correction Factor(dB/m)
2. Correction Factor(dB/m) = Antenna Factor(dB/m) + Cable Factor(dB) – Pre-Amplifier Factor(dB)
3. Margin value = Emission Level – Limit value
4. The other emission levels were very low against the limit.
5. " \* ": Fundamental frequency.
6. " # ": The radiated frequency is out of the restricted band.

**Mode A**

**BELOW 1GHz WORST-CASE DATA**

<b>RF Mode</b>	TX 802.11ac (VHT20)	<b>Channel</b>	CH 165 : 5825MHz
<b>Frequency Range</b>	9kHz ~ 1GHz	<b>Detector Function</b>	Quasi-Peak (QP)

Antenna Polarity & Test Distance : Horizontal at 3 m								
No	Frequency (MHz)	Emission Level (dBuV/m)	Limit (dBuV/m)	Margin (dB)	Antenna Height (m)	Table Angle (Degree)	Raw Value (dBuV)	Correction Factor (dB/m)
1	43.58	32.16 QP	40.00	-7.84	2.71 H	213	39.41	-7.25
2	90.14	25.82 QP	43.50	-17.68	3.07 H	177	38.19	-12.37
3	183.26	25.51 QP	43.50	-17.99	2.46 H	237	33.28	-7.77
4	320.03	24.00 QP	46.00	-22.00	2.14 H	269	27.51	-3.51
5	469.41	26.24 QP	46.00	-19.76	1.90 H	292	26.67	-0.43
6	619.76	31.09 QP	46.00	-14.91	1.65 H	318	28.34	2.75

**Remarks:**

1. Emission Level(dBuV/m) = Raw Value(dBuV) + Correction Factor(dB/m)
2. Correction Factor(dB/m) = Antenna Factor(dB/m) + Cable Factor(dB) – Pre-Amplifier Factor(dB)
3. Margin value = Emission Level – Limit value
4. The other emission levels were very low against the limit of frequency range 30MHz~1000MHz.
5. The emission levels were very low against the limit of frequency range 9kHz~30MHz: the amplitude of spurious emissions attenuated more than 20 dB below the permissible value to be report.

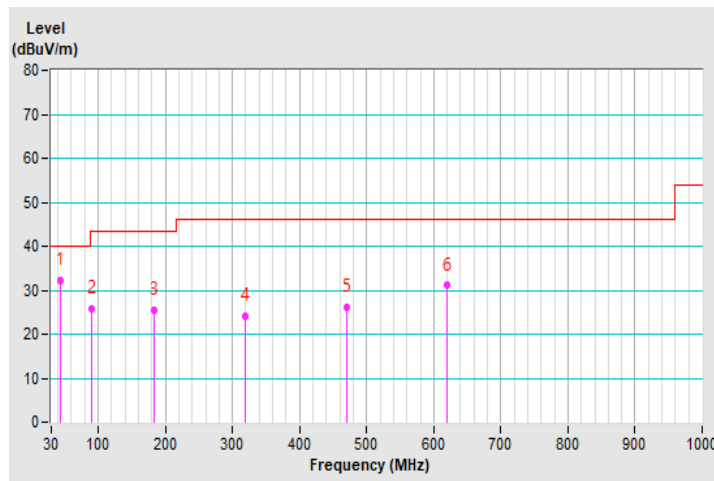

<b>RF Mode</b>	TX 802.11ac (VHT20)	<b>Channel</b>	CH 165 : 5825MHz
<b>Frequency Range</b>	9kHz ~ 1GHz	<b>Detector Function</b>	Quasi-Peak (QP)

Antenna Polarity & Test Distance : Vertical at 3 m								
No	Frequency (MHz)	Emission Level (dBUV/m)	Limit (dBUV/m)	Margin (dB)	Antenna Height (m)	Table Angle (Degree)	Raw Value (dBUV)	Correction Factor (dB/m)
1	82.38	31.82 QP	40.00	-8.18	1.00 V	360	43.62	-11.80
2	157.07	24.25 QP	43.50	-19.25	2.46 V	153	30.40	-6.15
3	297.72	24.33 QP	46.00	-21.67	2.77 V	123	28.56	-4.23
4	403.45	25.04 QP	46.00	-20.96	2.98 V	102	27.13	-2.09
5	524.70	28.27 QP	46.00	-17.73	3.20 V	80	27.80	0.47
6	636.25	30.75 QP	46.00	-15.25	3.41 V	60	27.51	3.24
7	755.56	33.60 QP	46.00	-12.40	3.60 V	41	28.12	5.48

**Remarks:**

1. Emission Level(dBuV/m) = Raw Value(dBuV) + Correction Factor(dB/m)
2. Correction Factor(dB/m) = Antenna Factor(dB/m) + Cable Factor(dB) – Pre-Amplifier Factor(dB)
3. Margin value = Emission Level – Limit value
4. The other emission levels were very low against the limit of frequency range 30MHz~1000MHz.
5. The emission levels were very low against the limit of frequency range 9kHz~30MHz: the amplitude of spurious emissions attenuated more than 20 dB below the permissible value to be report.

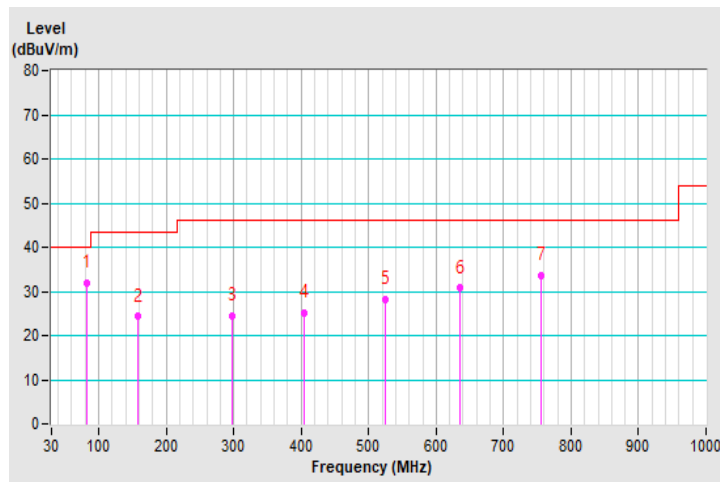

## 4.2 Conducted Emission Measurement

### 4.2.1 Limits of Conducted Emission Measurement

Frequency (MHz)	Conducted Limit (dBuV)	
	Quasi-peak	Average
0.15 - 0.5	66 - 56	56 - 46
0.50 - 5.0	56	46
5.0 - 30.0	60	50

Note: 1. The lower limit shall apply at the transition frequencies.

2. The limit decreases in line with the logarithm of the frequency in the range of 0.15 to 0.50MHz.

### 4.2.2 Test Instruments

Description & Manufacturer	Model no.	Serial No.	Calibrated Date	Calibrated Until
Test Receiver ESR3 R&S	ESR3	102412	2021/1/29	2022/1/28
LISN SCHWARZBECK	NSLK 8128	8128-244	2020/11/19	2021/11/18
LISN SCHWARZBECK	NNLK8129	8129229	2021/5/20	2022/5/19
DC LISN SCHWARZBECK	NNLK 8121	8121-808	2021/4/18	2022/4/17
LISN SCHWARZBECK	NNLK 8121	8121-731	2021/4/28	2022/4/27
LISN R&S	ENV216	101196	2021/4/26	2022/4/25
LISN R&S	ESH3-Z5	100220	2020/12/1	2021/11/30
LISN R&S	ESH3-Z6	844950/018	2021/7/25	2022/7/24
DC LISN R&S	ESH3-Z6	100219	2021/7/25	2022/7/24
High Voltage Probe Schwarzbeck	TK9420	00982	2021/1/8	2022/1/7
RF Coaxial Cable Commate	5D-FB	Cable-CO5-01	2021/1/29	2022/1/28
Attenuator STI	STI02-2200-10	NO.4	2021/9/3	2022/9/2
50 Ohms Terminator LYNICS	0900510	E1-01-305	2021/2/17	2022/2/16
Isolation Transformer Erika Fiedler	D-65396	017	2021/9/9	2022/9/8
Software BVADT	Cond_V7.3.7.4	NA	NA	NA

Note: 1. The calibration interval of the above test instruments is 12 months and the calibrations are traceable to NML/ROC and NIST/USA.

2. The test was performed in Linkou Conduction05

3. The VCCI Site Registration No. C-11093.

4. Tested Date: 2021/10/9



#### 4.2.3 Test Procedure

- The EUT was placed 0.4 meters from the conducting wall of the shielded room with EUT being connected to the power mains through a line impedance stabilization network (LISN). Other support units were connected to the power mains through another LISN. The two LISNs provide 50 ohm/ 50uH of coupling impedance for the measuring instrument.
- Both lines of the power mains connected to the EUT were checked for maximum conducted interference.
- The frequency range from 150kHz to 30MHz was searched. Emission levels under (Limit - 20dB) was not recorded.

**NOTE:** All modes of operation were investigated and the worst-case emissions are reported.

#### 4.2.4 Deviation from Test Standard

No deviation.

#### 4.2.5 Test Setup

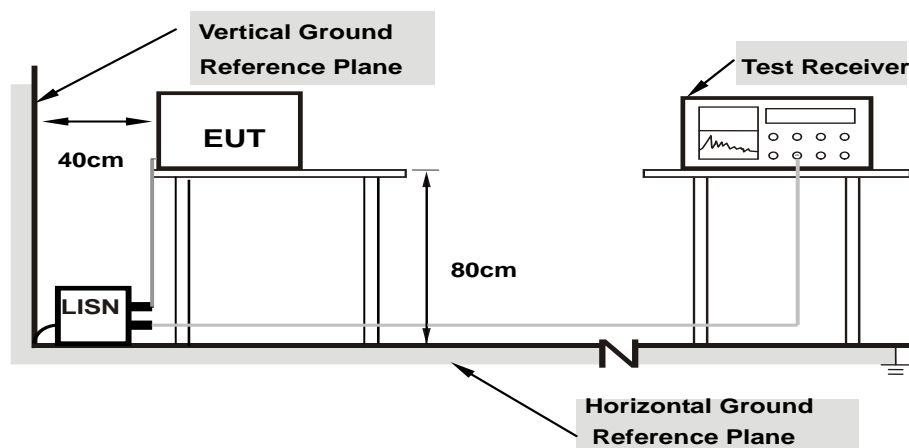

**Note: 1.Support units were connected to second LISN.**

For the actual test configuration, please refer to the attached file (Test Setup Photo).

#### 4.2.6 EUT Operating Condition

- Connected the EUT to Notebook PC or Adapter.
- Set the EUT under transmission condition continuously at specific channel frequency continuously.

#### 4.2.7 Test Results

##### Mode A

<b>RF Mode</b>	TX 802.11ac (VHT20)	<b>Channel</b>	CH 165 : 5825MHz
<b>Frequency Range</b>	150kHz ~ 30MHz	<b>Detector Function &amp; Resolution Bandwidth</b>	Quasi-Peak (QP) / Average (AV), 9kHz

Phase Of Power : Line (L)										
No	Frequency (MHz)	Correction Factor (dB)	Reading Value (dBuV)		Emission Level (dBuV)		Limit (dBuV)		Margin (dB)	
			Q.P.	AV.	Q.P.	AV.	Q.P.	AV.	Q.P.	AV.
1	0.16105	9.89	31.59	13.63	41.48	23.52	65.41	55.41	-23.93	-31.89
2	0.33500	9.90	23.29	4.74	33.19	14.64	59.33	49.33	-26.14	-34.69
3	0.75600	9.95	22.40	11.30	32.35	21.25	56.00	46.00	-23.65	-24.75
4	2.12000	10.03	14.34	7.03	24.37	17.06	56.00	46.00	-31.63	-28.94
5	4.01200	10.14	17.26	10.34	27.40	20.48	56.00	46.00	-28.60	-25.52
6	7.52800	10.28	17.30	10.49	27.58	20.77	60.00	50.00	-32.42	-29.23

##### Remarks:

1. Q.P. and AV. are abbreviations of quasi-peak and average individually.
2. The emission levels of other frequencies were very low against the limit.
3. Margin value = Emission level – Limit value
4. Correction factor = Insertion loss + Cable loss
5. Emission Level = Correction Factor + Reading Value

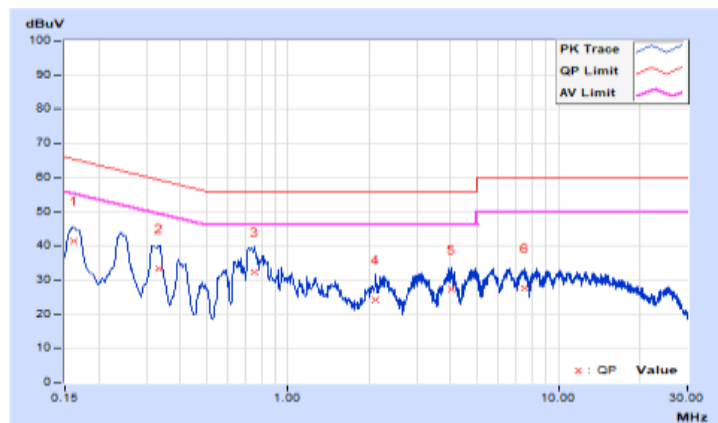

<b>RF Mode</b>	TX 802.11ac (VHT20)	<b>Channel</b>	CH 165 : 5825MHz
<b>Frequency Range</b>	150kHz ~ 30MHz	<b>Detector Function &amp; Resolution Bandwidth</b>	Quasi-Peak (QP) / Average (AV), 9kHz

Phase Of Power : Neutral (N)										
No	Frequency (MHz)	Correction Factor (dB)	Reading Value (dBuV)		Emission Level (dBuV)		Limit (dBuV)		Margin (dB)	
			Q.P.	AV.	Q.P.	AV.	Q.P.	AV.	Q.P.	AV.
1	0.16148	9.91	33.29	15.95	43.20	25.86	65.39	55.39	-22.19	-29.53
2	0.24292	9.91	30.00	14.07	39.91	23.98	62.00	52.00	-22.09	-28.02
3	0.75600	9.97	25.38	10.84	35.35	20.81	56.00	46.00	-20.65	-25.19
4	3.03600	10.10	17.69	11.19	27.79	21.29	56.00	46.00	-28.21	-24.71
5	4.85200	10.18	18.83	11.29	29.01	21.47	56.00	46.00	-26.99	-24.53
6	8.07200	10.31	17.04	10.68	27.35	20.99	60.00	50.00	-32.65	-29.01

**Remarks:**

1. Q.P. and AV. are abbreviations of quasi-peak and average individually.
2. The emission levels of other frequencies were very low against the limit.
3. Margin value = Emission level – Limit value
4. Correction factor = Insertion loss + Cable loss
5. Emission Level = Correction Factor + Reading Value

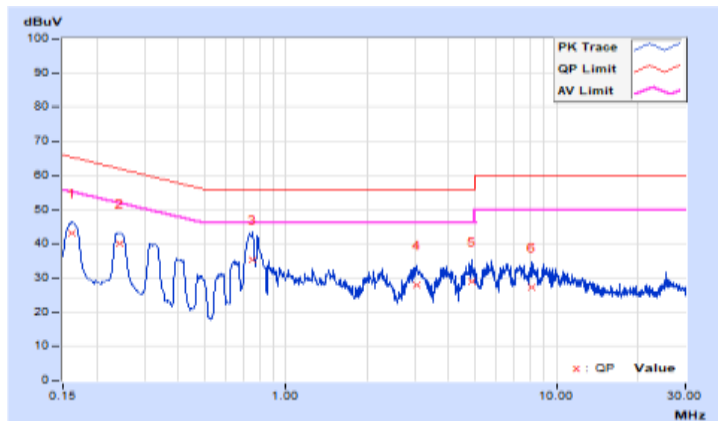

**Mode B**

<b>RF Mode</b>	TX 802.11ac (VHT20)	<b>Channel</b>	CH 165 : 5825MHz
<b>Frequency Range</b>	150kHz ~ 30MHz	<b>Detector Function &amp; Resolution Bandwidth</b>	Quasi-Peak (QP) / Average (AV), 9kHz

Phase Of Power : Line (L)										
No	Frequency (MHz)	Correction Factor (dB)	Reading Value (dBuV)		Emission Level (dBuV)		Limit (dBuV)		Margin (dB)	
			Q.P.	AV.	Q.P.	AV.	Q.P.	AV.	Q.P.	AV.
1	0.21350	9.89	24.49	12.32	34.38	22.21	63.07	53.07	-28.69	-30.86
2	0.43800	9.91	22.34	12.33	32.25	22.24	57.10	47.10	-24.85	-24.86
3	1.70000	10.01	5.69	0.62	15.70	10.63	56.00	46.00	-40.30	-35.37
4	3.81600	10.13	21.89	13.40	32.02	23.53	56.00	46.00	-23.98	-22.47
5	7.67600	10.29	22.15	15.67	32.44	25.96	60.00	50.00	-27.56	-24.04
6	8.94400	10.34	21.28	14.13	31.62	24.47	60.00	50.00	-28.38	-25.53

**Remarks:**

1. Q.P. and AV. are abbreviations of quasi-peak and average individually.
2. The emission levels of other frequencies were very low against the limit.
3. Margin value = Emission level – Limit value
4. Correction factor = Insertion loss + Cable loss
5. Emission Level = Correction Factor + Reading Value

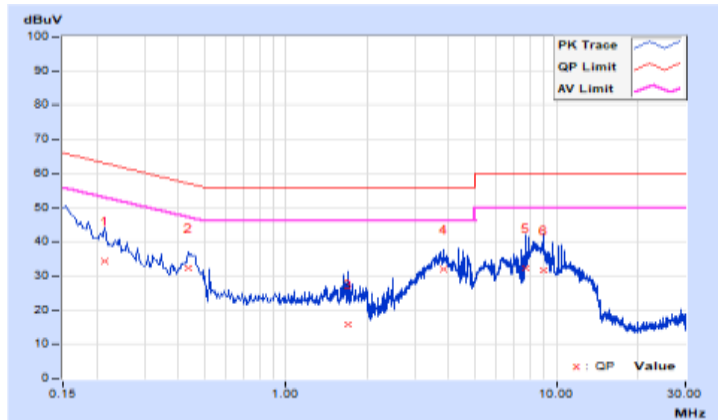

<b>RF Mode</b>	TX 802.11ac (VHT20)	<b>Channel</b>	CH 165 : 5825MHz
<b>Frequency Range</b>	150kHz ~ 30MHz	<b>Detector Function &amp; Resolution Bandwidth</b>	Quasi-Peak (QP) / Average (AV), 9kHz

Phase Of Power : Neutral (N)										
No	Frequency (MHz)	Correction Factor (dB)	Reading Value (dBuV)		Emission Level (dBuV)		Limit (dBuV)		Margin (dB)	
			Q.P.	AV.	Q.P.	AV.	Q.P.	AV.	Q.P.	AV.
1	0.15800	9.91	34.19	17.27	44.10	27.18	65.57	55.57	-21.47	-28.39
2	0.21800	9.91	25.71	12.07	35.62	21.98	62.89	52.89	-27.27	-30.91
3	0.77600	9.97	8.08	3.19	18.05	13.16	56.00	46.00	-37.95	-32.84
4	3.79600	10.14	24.11	15.10	34.25	25.24	56.00	46.00	-21.75	-20.76
5	5.52800	10.21	20.02	13.52	30.23	23.73	60.00	50.00	-29.77	-26.27
<b>6</b>	<b>8.31600</b>	<b>10.32</b>	<b>25.94</b>	<b>19.44</b>	<b>36.26</b>	<b>29.76</b>	<b>60.00</b>	<b>50.00</b>	<b>-23.74</b>	<b>-20.24</b>

**Remarks:**

1. Q.P. and AV. are abbreviations of quasi-peak and average individually.
2. The emission levels of other frequencies were very low against the limit.
3. Margin value = Emission level – Limit value
4. Correction factor = Insertion loss + Cable loss
5. Emission Level = Correction Factor + Reading Value

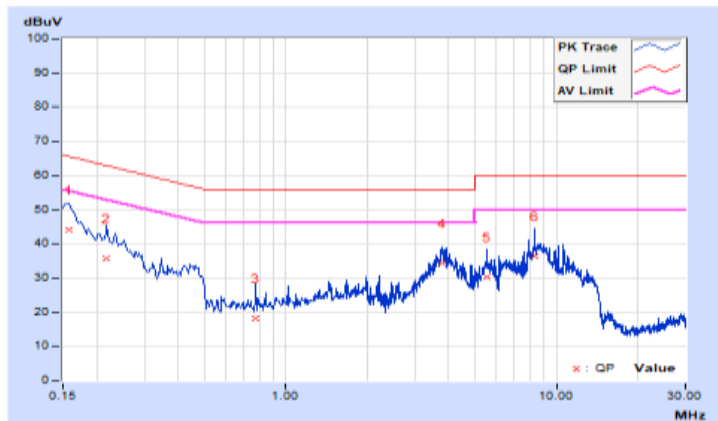

### 4.3 Transmit Power Measurement

#### 4.3.1 Limits of Transmit Power Measurement

Operation Band	EUT Category		Limit
U-NII-1		Outdoor Access Point	1 Watt (30 dBm) (Max. e.i.r.p $\leq$ 125mW(21 dBm) at any elevation angle above 30 degrees as measured from the horizon)
		Fixed point-to-point Access Point	1 Watt (30 dBm)
		Indoor Access Point	1 Watt (30 dBm)
	√	Client device	250mW (24 dBm)
U-NII-2A	--		250mW (24 dBm) or 11 dBm+10 log B*
U-NII-2C	--		250mW (24 dBm) or 11 dBm+10 log B*
U-NII-3	√		1 Watt (30 dBm)

\*B is the 26 dB emission bandwidth in megahertz

#### 4.3.2 Test Setup

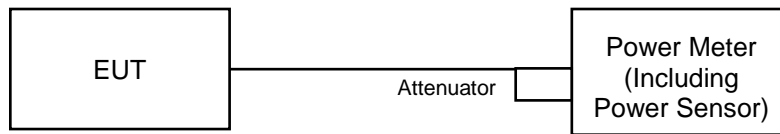

#### 4.3.3 Test Instruments

Description & Manufacturer	Model no.	Serial No.	Calibrated Date	Calibrated Until
Pulse Power Sensor Anritsu	MA2411B	0738404	2021/4/15	2022/4/14
Peak Power meter Anritsu	ML2495A	0842014	2021/4/15	2022/4/14

- NOTE:**
1. The calibration interval of the above test instruments is 12 months. And the calibrations are traceable to NML/ROC and NIST/USA.
  2. The test was performed in LK - Oven
  3. Tested Date: 2021/10/30

#### 4.3.4 Test Procedure

##### For Average Power Measurement

Method PM is used to perform output power measurement, trigger and gating function of wide band power meter is enabled to measure max output power of TX on burst and set the detector to average. Duty factor is not added to measured value.

#### 4.3.5 Deviation from Test Standard

No deviation.

#### 4.3.6 EUT Operating Condition

The software provided by client to enable the EUT under transmission condition continuously at lowest, middle and highest channel frequencies individually.

#### 4.3.7 Test Result

##### Mode A 802.11a

CHAN.	FREQ. (MHz)	Average Power (mW)	Average Power (dBm)	Power Limit (dBm)	Pass/Fail
36	5180	10.471	10.20	24	Pass
40	5200	10.715	10.30	24	Pass
48	5240	10.715	10.30	24	Pass
149	5745	3.89	5.90	30	Pass
157	5785	3.89	5.90	30	Pass
165	5825	3.802	5.80	30	Pass

##### 802.11ac (VHT20)

CHAN.	FREQ. (MHz)	Average Power (mW)	Average Power (dBm)	Power Limit (dBm)	Pass/Fail
36	5180	10.715	10.30	24	Pass
40	5200	10.715	10.30	24	Pass
48	5240	10.965	10.40	24	Pass
149	5745	3.89	5.90	30	Pass
157	5785	3.802	5.80	30	Pass
165	5825	3.89	5.90	30	Pass

##### 802.11ac (VHT40)

CHAN.	FREQ. (MHz)	Average Power (mW)	Average Power (dBm)	Power Limit (dBm)	Pass/Fail
38	5190	12.023	10.80	24	Pass
46	5230	<b>12.303</b>	10.90	24	Pass
151	5755	4.169	6.20	30	Pass
159	5795	<b>4.266</b>	6.30	30	Pass

##### 802.11ac (VHT80)

CHAN.	FREQ. (MHz)	Average Power (mW)	Average Power (dBm)	Power Limit (dBm)	Pass/Fail
42	5210	10.471	10.20	24	Pass
155	5775	3.715	5.70	30	Pass



#### 4.4 Occupied Bandwidth Measurement

##### 4.4.1 Test Setup

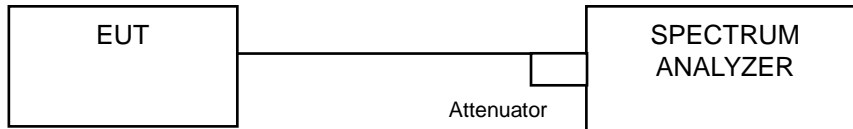

##### 4.4.2 Test Instruments

Description & Manufacturer	Model no.	Serial No.	Calibrated Date	Calibrated Until
Spectrum Analyzer R&S	FSV40	101042	2021/9/9	2022/9/8

- NOTE:**
1. The calibration interval of the above test instruments is 12 months. And the calibrations are traceable to NML/ROC and NIST/USA.
  2. The test was performed in LK - Oven
  3. Tested Date: 2021/10/30

##### 4.4.3 Test Procedure

The transmitter output was connected to the spectrum analyzer through an attenuator. The bandwidth of the fundamental frequency was measured by spectrum analyzer with resolution bandwidth in the range of 1% to 5% of the anticipated emission bandwidth, and a video bandwidth at least 3x the resolution bandwidth and set the detector to SAMPLE. The width of a frequency band such that, below the lower and above the upper frequency limits, the mean powers emitted are each equal to a specified percentage 0.5 %of the total mean power of a given emission.

#### 4.4.4 Test Results

##### Mode A 802.11a

Channel	Channel Frequency (MHz)	Occupied Bandwidth (MHz)
36	5180	16.92
40	5200	16.92
48	5240	16.92
149	5745	16.95
157	5785	16.92
165	5825	16.92

##### 802.11ac (VHT20)

Channel	Channel Frequency (MHz)	Occupied Bandwidth (MHz)
36	5180	18
40	5200	18
48	5240	18
149	5745	18.12
157	5785	18.12
165	5825	18

##### 802.11ac (VHT40)

Channel	Channel Frequency (MHz)	Occupied Bandwidth (MHz)
38	5190	36.48
46	5230	36.72
151	5755	36.72
159	5795	36.72

##### 802.11ac (VHT80)

Channel	Channel Frequency (MHz)	Occupied Bandwidth (MHz)
42	5210	75.84
155	5775	75.36

### Spectrum Plot of Worst Value

**802.11a**

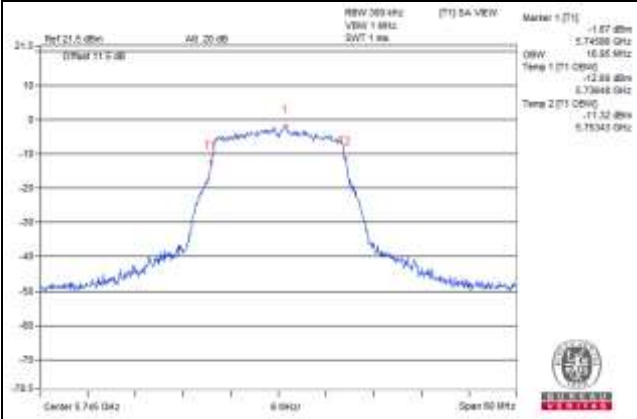

**802.11ac (VHT20)**

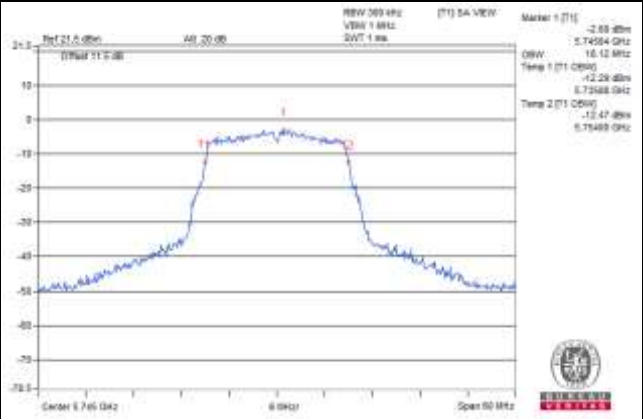

**802.11ac (VHT40)**

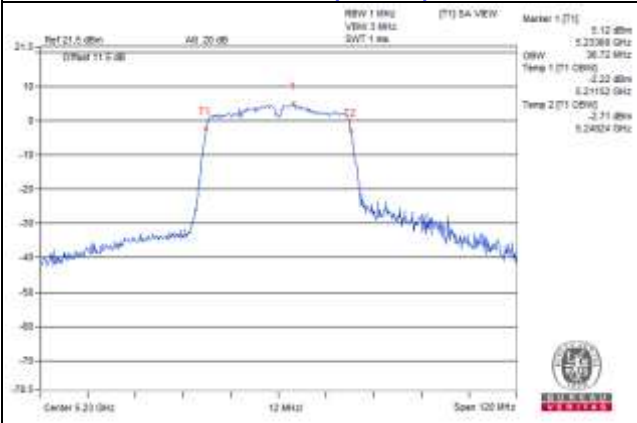

**802.11ac (VHT80)**

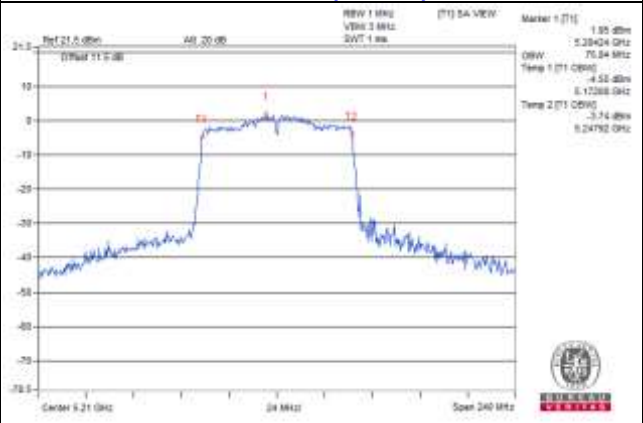

### Spectrum Plot for near by DFS band

**802.11a / CH48**

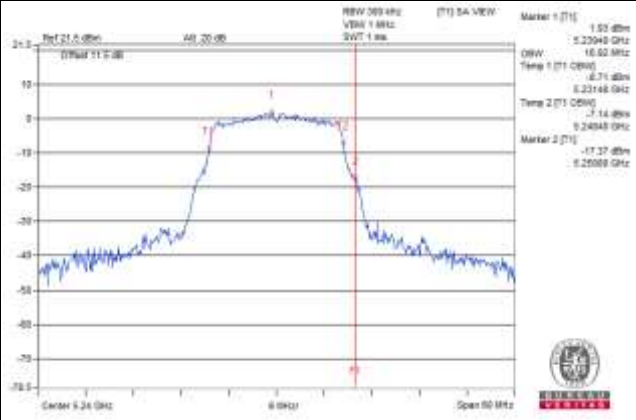

**802.11ac (VHT20) / CH48**

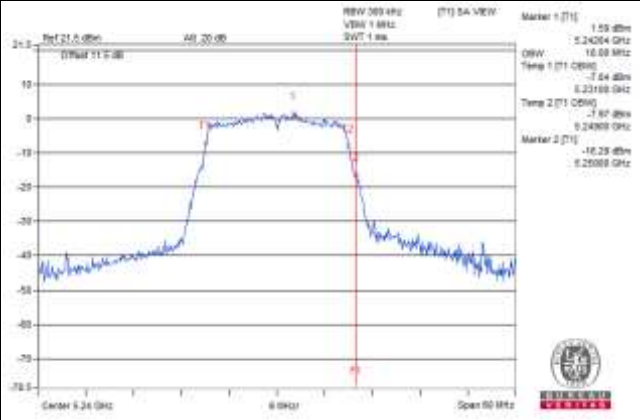

**802.11ac (VHT40) / CH46**

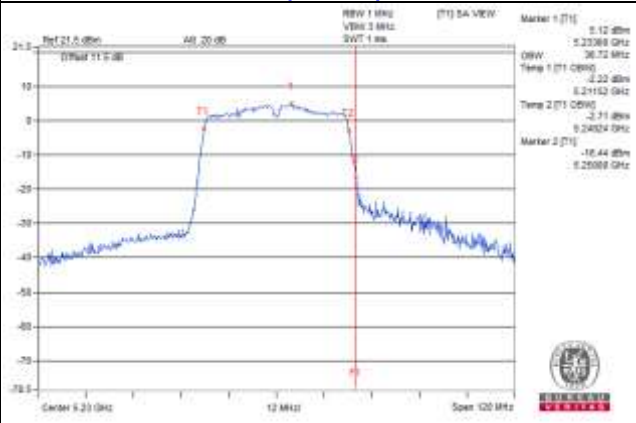

**802.11ac (VHT80) / CH42**

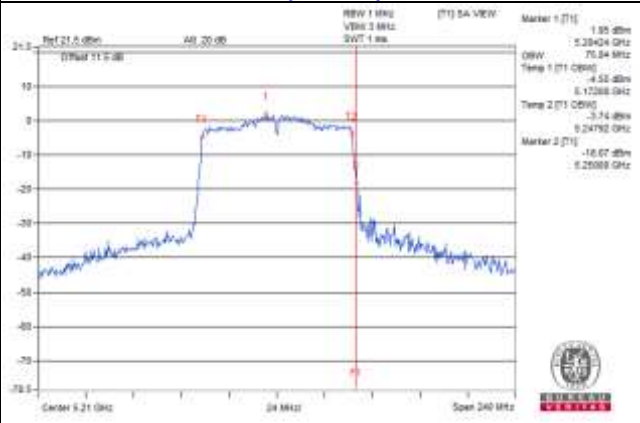

**Spectrum Plot for near by DFS band**

**802.11a / CH149**

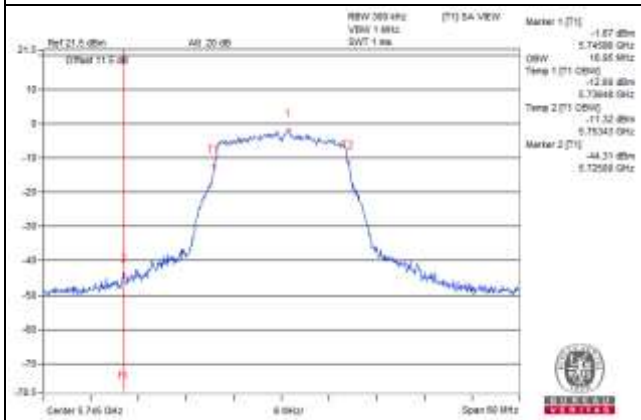

**802.11ac (VHT20) / CH149**

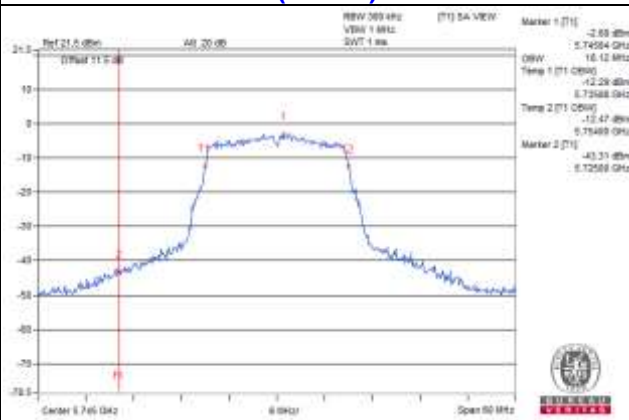

**802.11ac (VHT40) / CH151**

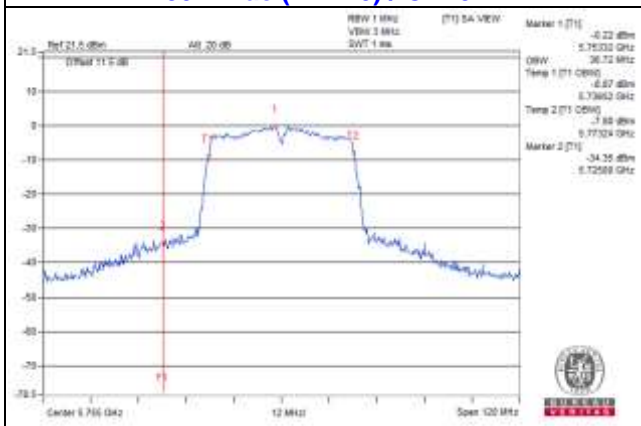

**802.11ac (VHT80) / CH155**

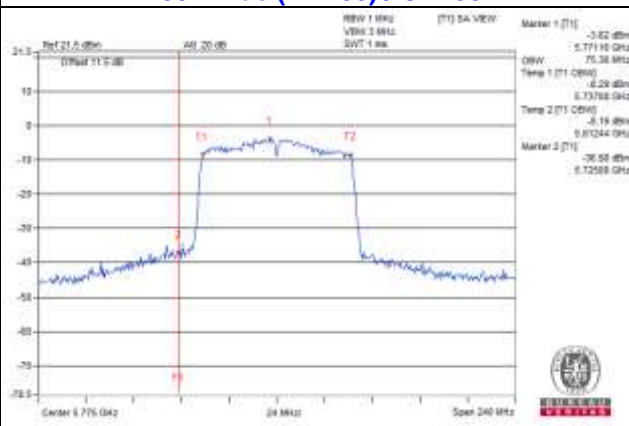

## 4.5 Peak Power Spectral Density Measurement

### 4.5.1 Limits of Peak Power Spectral Density Measurement

Operation Band	EUT Category		Limit
U-NII-1		Outdoor Access Point	17dBm/ MHz
		Fixed point-to-point Access Point	
		Indoor Access Point	
	√	Client device	11dBm/ MHz
U-NII-2A	--		11dBm/ MHz
U-NII-2C	--		11dBm/ MHz
U-NII-3	√		30dBm/ 500kHz

### 4.5.2 Test Setup

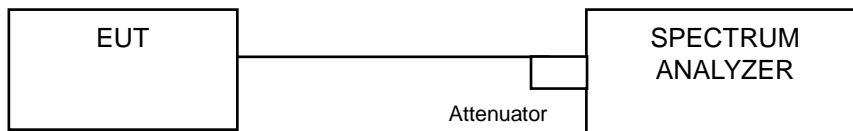

### 4.5.3 Test Instruments

Refer to section 4.4.2 to get information of above instrument.

### 4.5.4 Test Procedure

#### For U-NII-1 band:

Using method SA-2

- 1) Set span to encompass the entire emission bandwidth (EBW) of the signal.
- 2) Set RBW = 30 kHz, Set VBW ≥ 1 MHz, Detector = RMS
- 3) Set Channel power measure = 1MHz
- 4) Sweep time = auto, trigger set to “free run”.
- 5) Trace average at least 100 traces in power averaging mode.
- 6) Record the max value and add 10 log (1/duty cycle)

#### For U-NII-3 band:

- 1) Set span to encompass the entire emission bandwidth (EBW) of the signal.
- 2) Set RBW = 300 kHz, Set VBW ≥ 1 MHz, Detector = RMS
- 3) Use the peak marker function to determine the maximum power level in any 300 kHz band segment within the fundamental EBW.
- 4) Scale the observed power level to an equivalent value in 500 kHz by adjusting (increasing) the measured power by a bandwidth correction factor (BWCF) where  $BWCF = 10\log(500\text{kHz}/300\text{kHz})$
- 5) Sweep time = auto, trigger set to “free run”.
- 6) Trace average at least 100 traces in power averaging mode.
- 7) Record the max value and add 10 log (1/duty cycle).

### 4.5.5 Deviation from Test Standard

No deviation.

### 4.5.6 EUT Operating Condition

Same as Item 4.3.6.

#### 4.5.7 Test Results

##### Mode A

##### For U-NII-1:

##### 802.11a

Chan.	Chan. Freq. (MHz)	PSD (dBm/MHz)	Max. PSD Limit (dBm/MHz)	Pass / Fail
36	5180	-1.18	11.00	Pass
40	5200	-1.31	11.00	Pass
48	5240	-1.73	11.00	Pass

##### 802.11ac (VHT20)

Chan.	Chan. Freq. (MHz)	PSD w/o Duty Factor (dBm/MHz)	Duty Factor (dB)	PSD (dBm/MHz)	Max. PSD Limit (dBm/MHz)	Pass / Fail
36	5180	-2.78	0.20	-2.58	11.00	Pass
40	5200	-2.96	0.20	-2.76	11.00	Pass
48	5240	-2.52	0.20	-2.32	11.00	Pass

Note: Refer to section 3.3 for duty cycle spectrum plot.

##### 802.11ac (VHT40)

Chan.	Chan. Freq. (MHz)	PSD w/o Duty Factor (dBm/MHz)	Duty Factor (dB)	PSD (dBm/MHz)	Max. PSD Limit (dBm/MHz)	Pass / Fail
38	5190	-6.95	0.40	-6.55	11.00	Pass
46	5230	-7.27	0.40	-6.87	11.00	Pass

Note: Refer to section 3.3 for duty cycle spectrum plot.

### 802.11ac (VHT80)

Chan.	Chan. Freq. (MHz)	PSD w/o Duty Factor (dBm/MHz)	Duty Factor (dB)	PSD (dBm/MHz)	Max. PSD Limit (dBm/MHz)	Pass / Fail
42	5210	-9.16	0.59	-8.57	11.00	Pass

Note: Refer to section 3.3 for duty cycle spectrum plot.

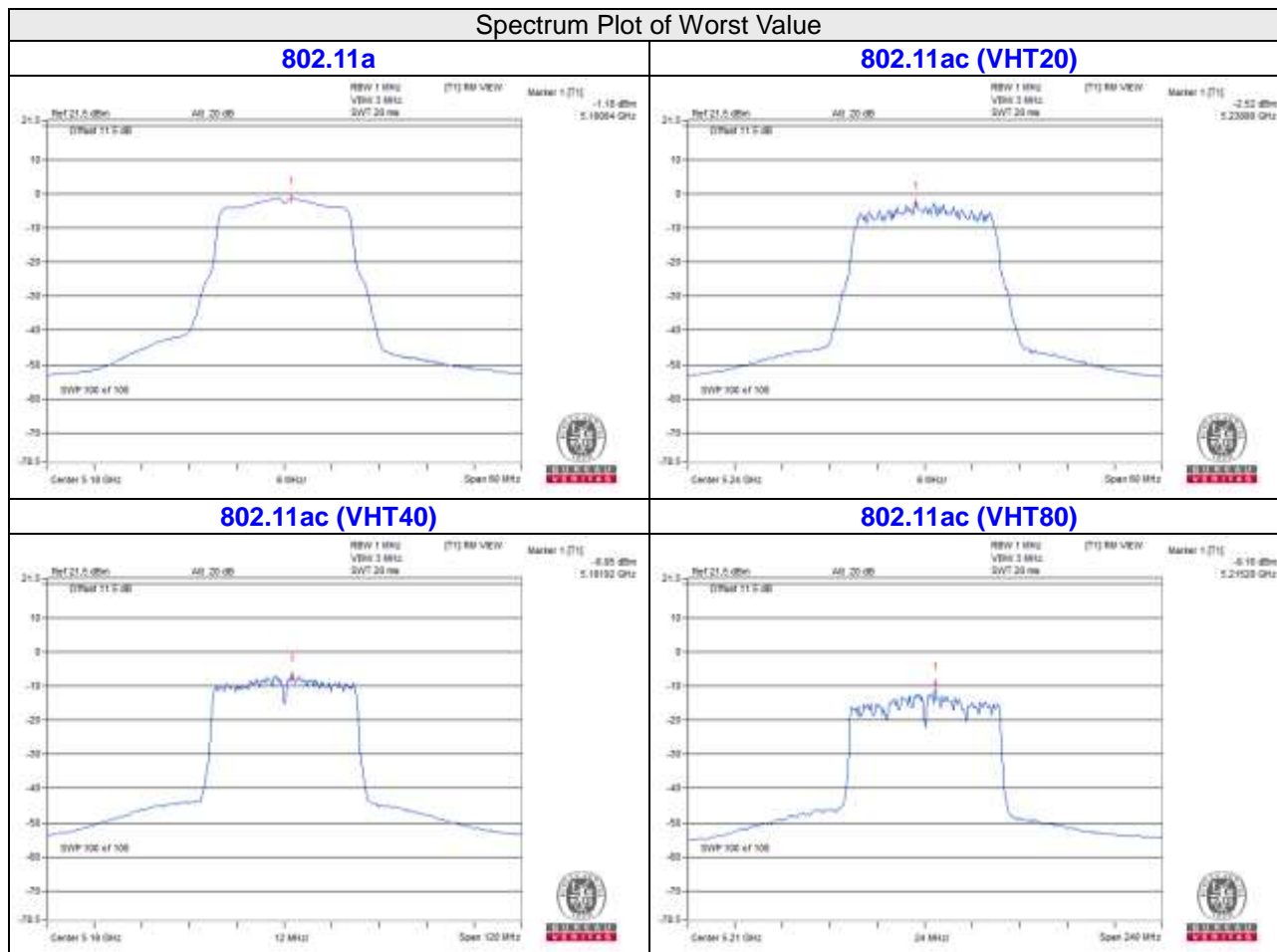



**Mode A**  
**For U-NII-3:**

**802.11a**

Chan.	Chan. Freq. (MHz)	PSD (dBm/300kHz)	PSD (dBm/500kHz)	PSD Limit (dBm/500Hz)	Pass /Fail
149	5745	-14.18	-11.96	30	Pass
157	5785	-14.35	-12.13	30	Pass
165	5825	-15.27	-13.05	30	Pass

**802.11ac (VHT20)**

Chan.	Chan. Freq. (MHz)	PSD w/o Duty Factor (dBm/300kHz)	Duty Factor (dB)	PSD (dBm/300kHz)	PSD (dBm/500kHz)	PSD Limit (dBm/500Hz)	Pass /Fail
149	5745	-16.08	0.20	-15.88	-13.66	30	Pass
157	5785	-16.95	0.20	-16.76	-14.54	30	Pass
165	5825	-17.88	0.20	-17.69	-15.47	30	Pass

Note: Refer to section 3.3 for duty cycle spectrum plot.

**802.11ac (VHT40)**

Chan.	Chan. Freq. (MHz)	PSD w/o Duty Factor (dBm/300kHz)	Duty Factor (dB)	PSD (dBm/300kHz)	PSD (dBm/500kHz)	PSD Limit (dBm/500Hz)	Pass /Fail
151	5755	-20.94	0.40	-20.54	-18.32	30	Pass
159	5795	-20.65	0.40	-20.25	-18.03	30	Pass

Note: Refer to section 3.3 for duty cycle spectrum plot.

**802.11ac (VHT80)**

Chan.	Chan. Freq. (MHz)	PSD w/o Duty Factor (dBm/300kHz)	Duty Factor (dB)	PSD (dBm/300kHz)	PSD (dBm/500kHz)	PSD Limit (dBm/500Hz)	Pass /Fail
155	5775	-23.2	0.59	-22.61	-20.39	30	Pass

Note: Refer to section 3.3 for duty cycle spectrum plot.

Spectrum Plot of Worst Value

802.11a

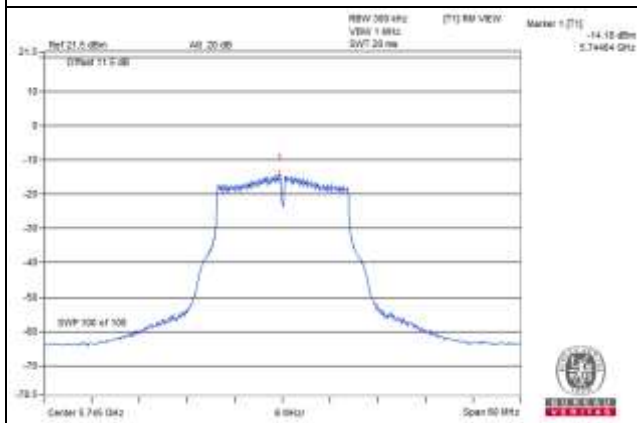

802.11ac (VHT20)

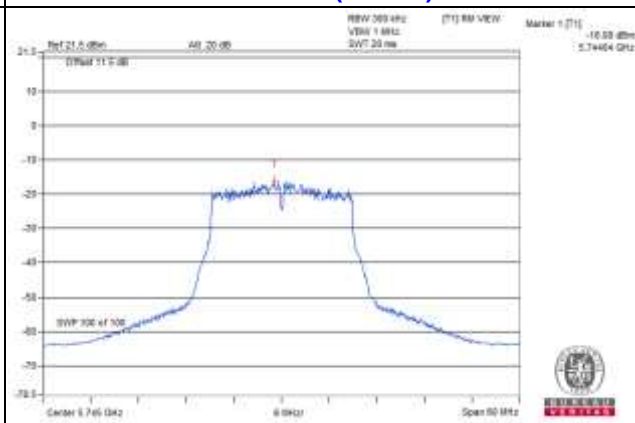

802.11ac (VHT40)

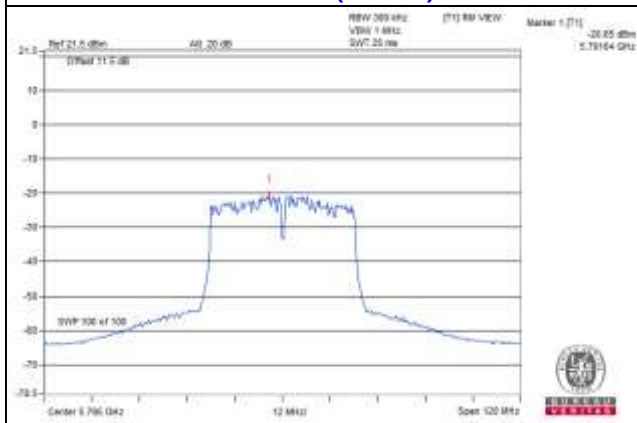

802.11ac (VHT80)

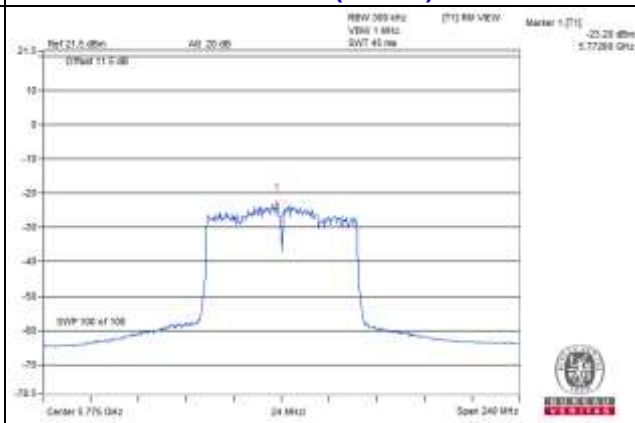

## 4.6 Frequency Stability Measurement

### 4.6.1 Limits of Frequency Stability Measurement

The frequency of the carrier signal shall be maintained within band of operation

### 4.6.2 Test Setup

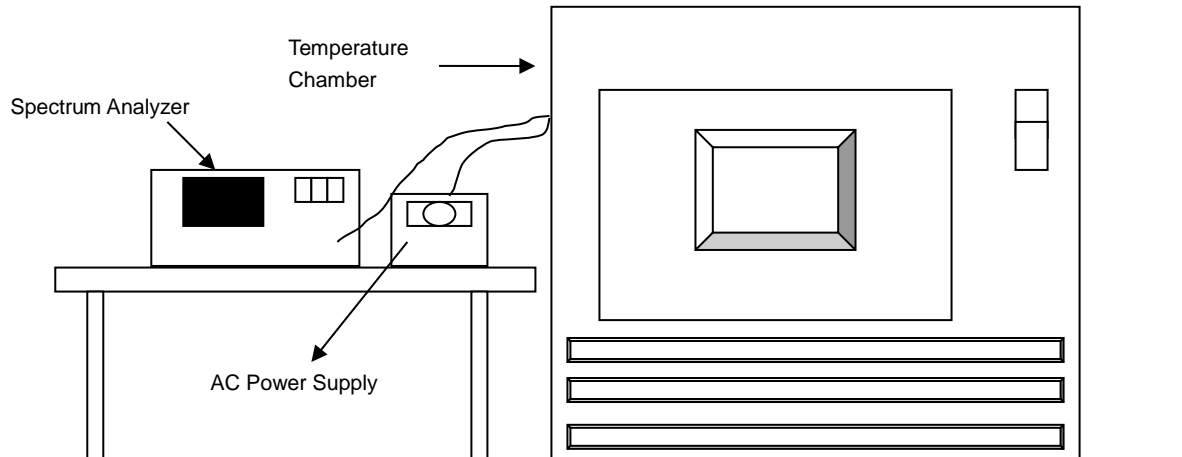

### 4.6.3 Test Instruments

Description & Manufacturer	Model no.	Serial No.	Calibrated Date	Calibrated Until
Temperature & Humidity Chamber TERCHY	MHU-225AU	920409	2021/7/2	2022/7/1
Spectrum Analyzer R&S	FSV40	101042	2021/9/9	2022/9/8
Digital Multimeter Fluke	87-III	70360742	2021/6/24	2022/6/23
AC Power Source Preen	AFC-500W	F103040004	NA	NA

- NOTE:**
1. The calibration interval of the above test instruments is 12 months. And the calibrations are traceable to NML/ROC and NIST/USA.
  2. The test was performed in LK - Oven
  3. Tested Date: 2021/10/30

### 4.6.4 Test Procedure

- a. The EUT was placed inside the environmental test chamber and powered by nominal AC voltage.
- b. Turn the EUT on and couple its output to a spectrum analyzer.
- c. Turn the EUT off and set the chamber to the highest temperature specified.
- d. Allow sufficient time (approximately 30 min) for the temperature of the chamber to stabilize, turn the EUT on and measure the operating frequency after 2, 5, and 10 minutes.
- e. Repeat step d with the temperature chamber set to the next desired temperature.
- f. The test chamber was allowed to stabilize at +20 degree C for a minimum of 30 minutes. The supply voltage was then adjusted on the EUT from 85% to 115% and the frequency record.

### 4.6.5 Deviation from Test Standard

No deviation.

### 4.6.6 EUT Operating Condition

Set the EUT transmit at un-modulation mode to test frequency stability.

4.6.7 Test Results

Mode A

Frequency Stability Versus Temp.									
Operating Frequency: 5180 MHz									
TEMP. (°C)	Power Supply (Vac)	0 Minute		2 Minute		5 Minute		10 Minute	
		Measured Frequency (MHz)	Pass/Fail	Measured Frequency (MHz)	Pass/Fail	Measured Frequency (MHz)	Pass/Fail	Measured Frequency (MHz)	Pass/Fail
45	120	5180.0119	Pass	5180.0096	Pass	5180.0108	Pass	5180.0111	Pass
40	120	5180.0048	Pass	5180.0086	Pass	5180.0061	Pass	5180.0054	Pass
30	120	5180.0028	Pass	5179.9987	Pass	5180.0006	Pass	5180.0006	Pass
20	120	5179.9933	Pass	5179.9935	Pass	5179.9901	Pass	5179.9896	Pass
10	120	5179.9784	Pass	5179.978	Pass	5179.9793	Pass	5179.982	Pass
0	120	5179.9804	Pass	5179.9803	Pass	5179.9798	Pass	5179.9822	Pass

Frequency Stability Versus Voltage									
Operating Frequency: 5180 MHz									
TEMP. (°C)	Power Supply (Vac)	0 Minute		2 Minute		5 Minute		10 Minute	
		Measured Frequency (MHz)	Pass/Fail	Measured Frequency (MHz)	Pass/Fail	Measured Frequency (MHz)	Pass/Fail	Measured Frequency (MHz)	Pass/Fail
20	138	5180.001	Pass	5179.9969	Pass	5179.9989	Pass	5179.9971	Pass
	120	5179.9933	Pass	5179.9935	Pass	5179.9901	Pass	5179.9896	Pass
	102	5179.9852	Pass	5179.9812	Pass	5179.9828	Pass	5179.9846	Pass

## 4.7 6dB Bandwidth Measurement

### 4.7.1 Limits of 6dB Bandwidth Measurement

The minimum of 6dB Bandwidth Measurement is 0.5MHz.

### 4.7.2 Test Setup

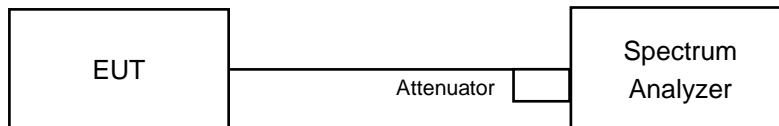

### 4.7.3 Test Instruments

Refer to section 4.4.2 to get information of above instrument.

### 4.7.4 Test Procedure

#### MEASUREMENT PROCEDURE REF

- a. Set resolution bandwidth (RBW) = 100kHz
- b. Set the video bandwidth (VBW)  $\geq 3 \times$  RBW, Detector = Peak.
- c. Trace mode = max hold.
- d. Sweep = auto couple.
- e. Measure the maximum width of the emission that is constrained by the frequencies associated with the two amplitude points (upper and lower) that are attenuated by 6 dB relative to the maximum level measured in the fundamental emission

### 4.7.5 Deviation from Test Standard

No deviation.

### 4.7.6 EUT Operating Condition

The software provided by client to enable the EUT under transmission condition continuously at lowest, middle and highest channel frequencies individually.

#### 4.7.7 Test Results

##### Mode A

##### 802.11a

Channel	Frequency (MHz)	6dB Bandwidth (MHz)	Minimum Limit (MHz)	Pass / Fail
149	5745	16.36	0.5	Pass
157	5785	16.39	0.5	Pass
165	5825	16.39	0.5	Pass

##### 802.11ac (VHT20)

Channel	Frequency (MHz)	6dB Bandwidth (MHz)	Minimum Limit (MHz)	Pass / Fail
149	5745	17.6	0.5	Pass
157	5785	17.57	0.5	Pass
165	5825	17.37	0.5	Pass

##### 802.11ac (VHT40)

Channel	Frequency (MHz)	6dB Bandwidth (MHz)	Minimum Limit (MHz)	Pass / Fail
151	5755	35.79	0.5	Pass
159	5795	35.9	0.5	Pass

##### 802.11ac (VHT80)

Channel	Frequency (MHz)	6dB Bandwidth (MHz)	Minimum Limit (MHz)	Pass / Fail
155	5775	75.8	0.5	Pass

Spectrum Plot of Worst Value

802.11a

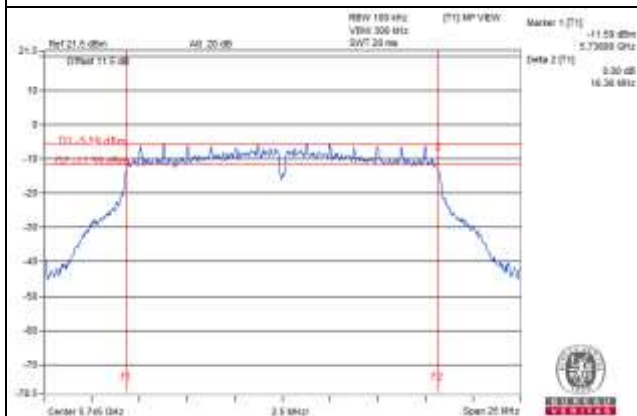

802.11ac (VHT20)

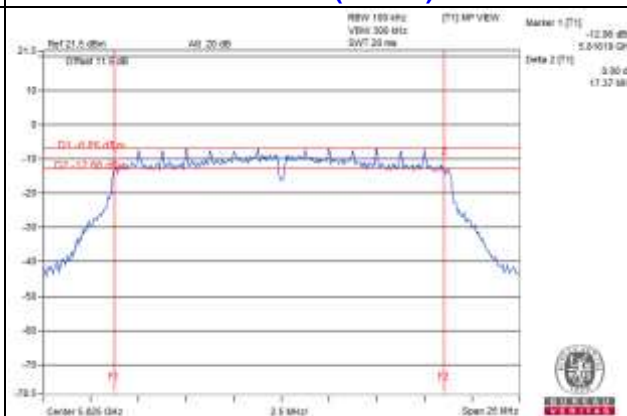

802.11ac (VHT40)

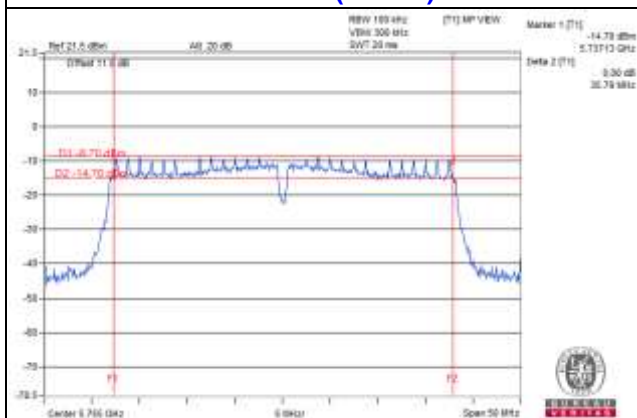

802.11ac (VHT80)

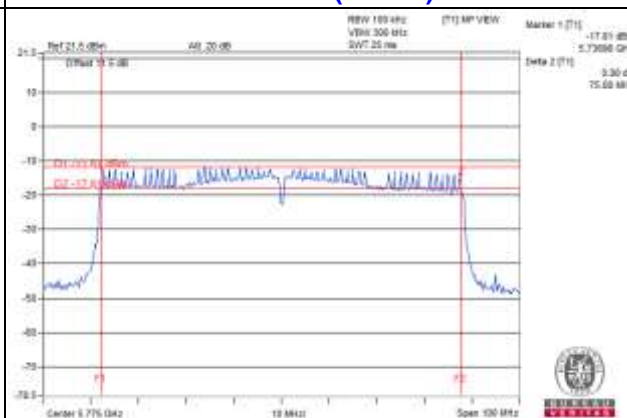

## 5 Pictures of Test Arrangements

Please refer to the attached file (Test Setup Photo).



## Annex A- Radiated Out of Band Emission (OOBE) Measurement (For U-NII-3 band)

### Mode A

#### 802.11a

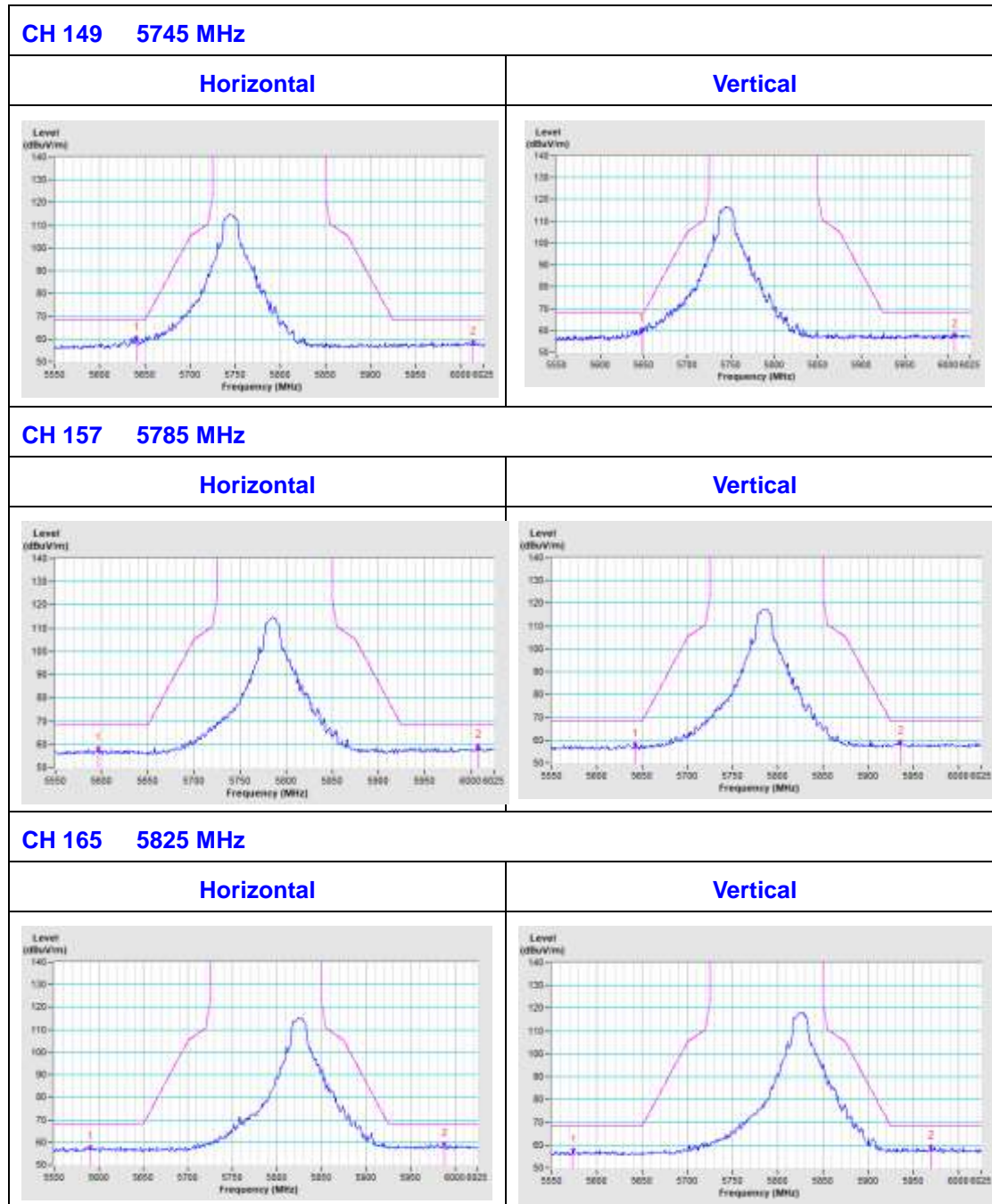

802.11ac (VHT20)

CH 149 5745 MHz

Horizontal

Vertical

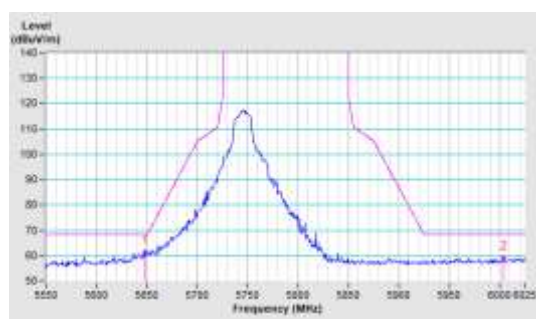
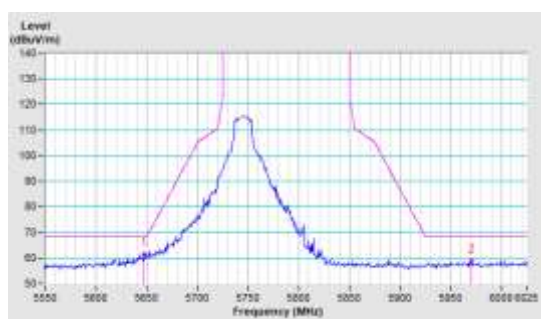

CH 157 5785 MHz

Horizontal

Vertical

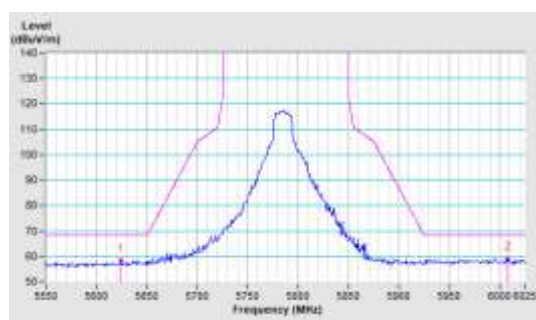
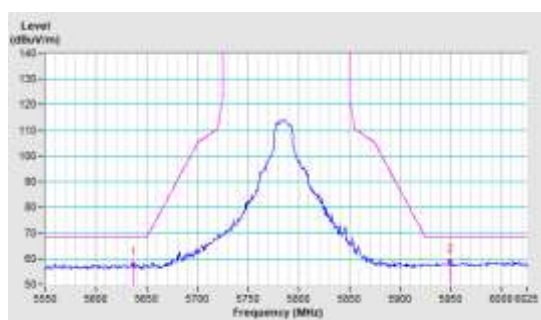

CH 165 5825 MHz

Horizontal

Vertical

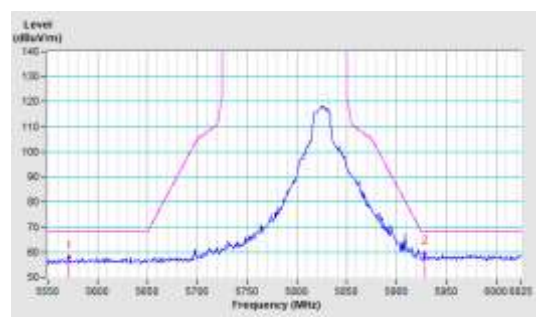
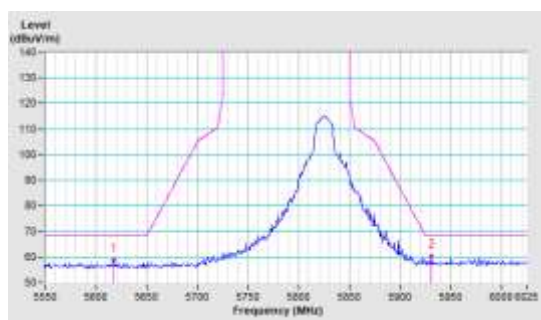

802.11ac (VHT40)

CH 151 5755 MHz

Horizontal

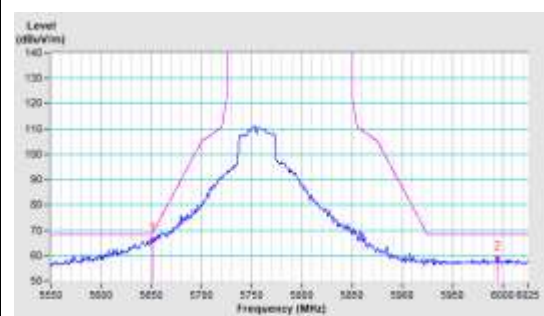

Vertical

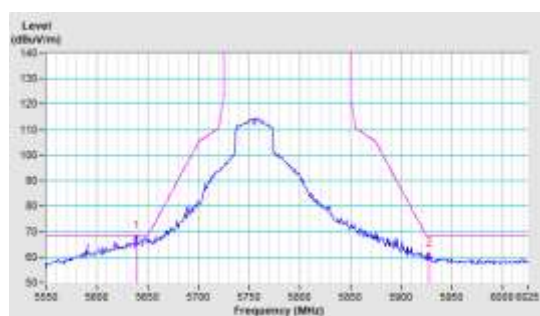

CH 159 5795 MHz

Horizontal

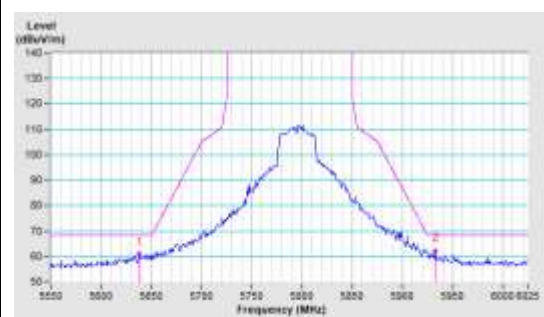

Vertical

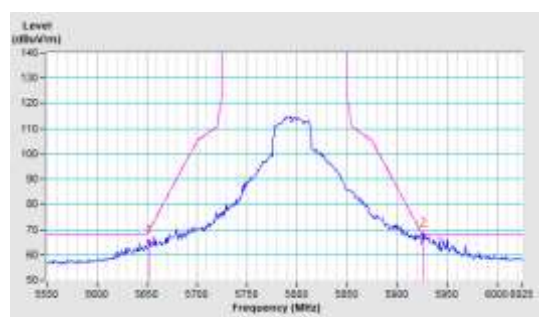

802.11ac (VHT80)

CH 155 5775 MHz

Horizontal

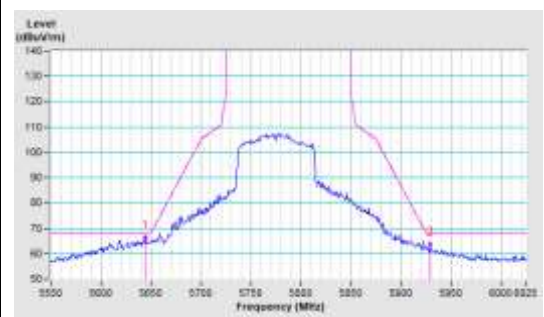

Vertical

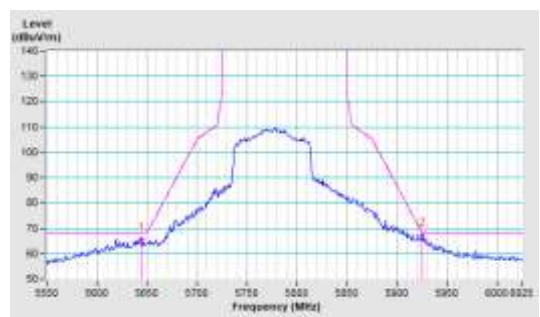

## Annex B- Band Edge Measurement

### Mode A

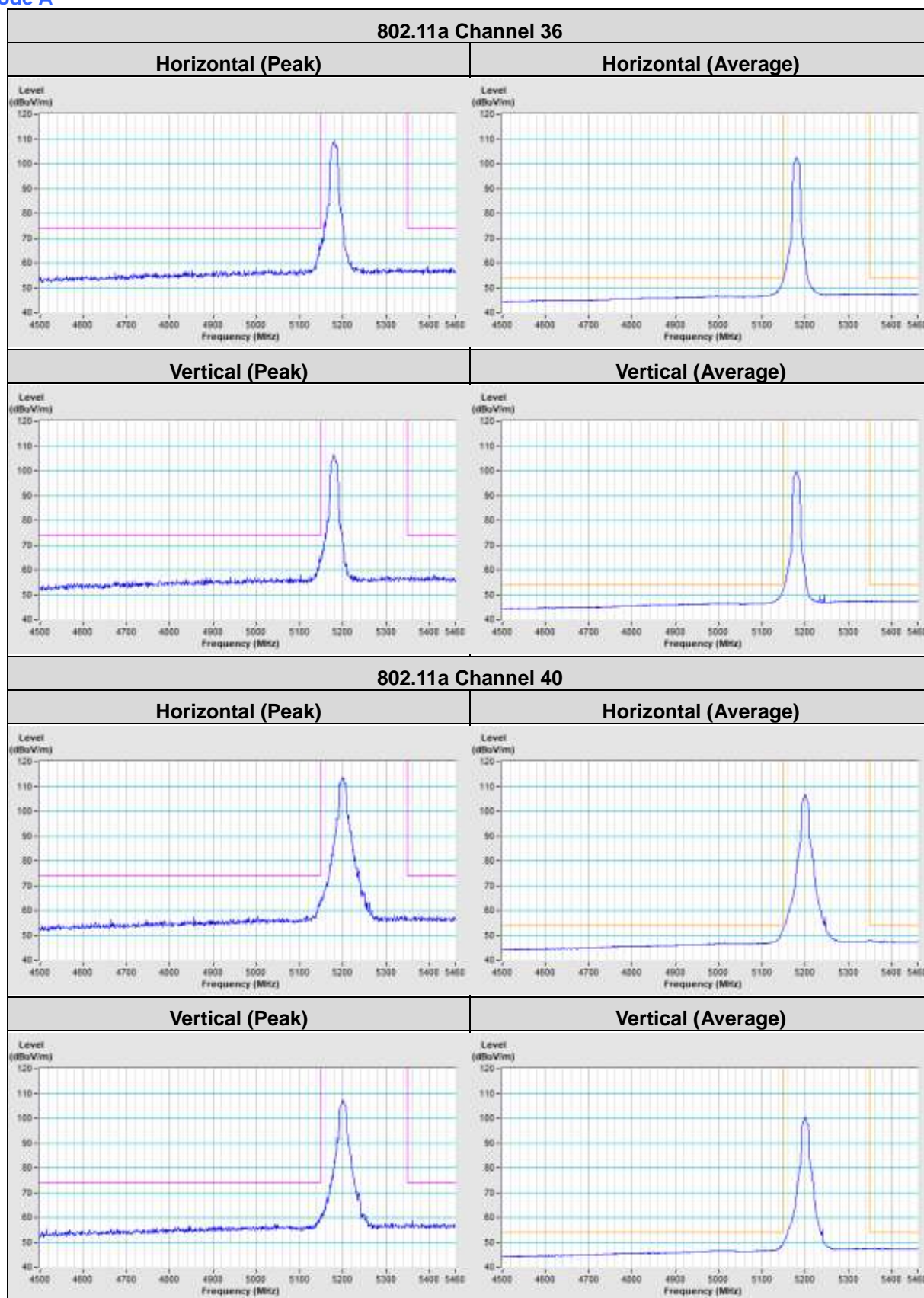

### 802.11a Channel 48

**Horizontal (Peak)**

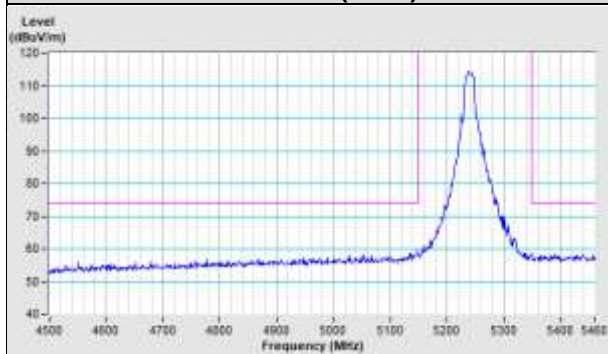

**Horizontal (Average)**

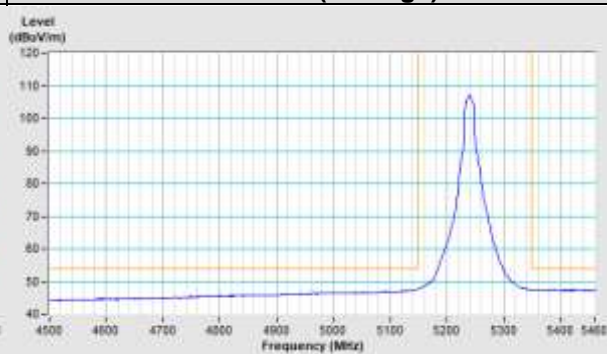

**Vertical (Peak)**

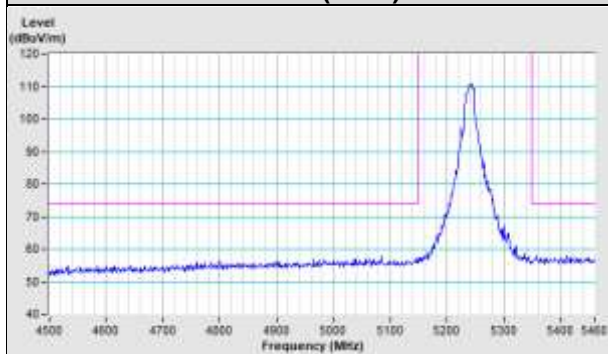

**Vertical (Average)**

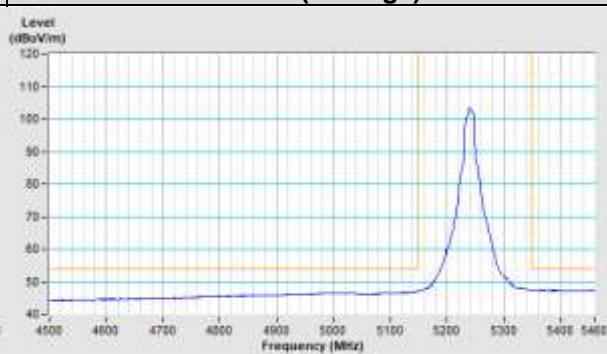

**802.11ac (VHT20) Channel 36**

<b>Horizontal (Peak)</b>	<b>Horizontal (Average)</b>
--------------------------	-----------------------------

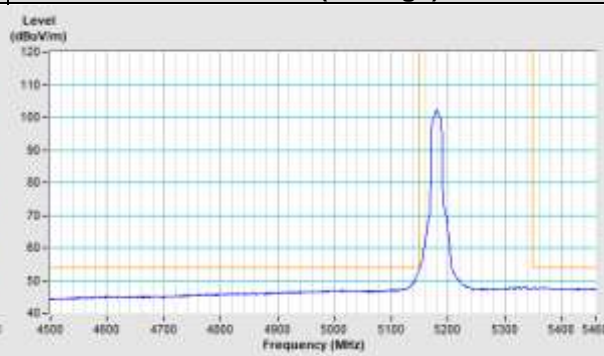
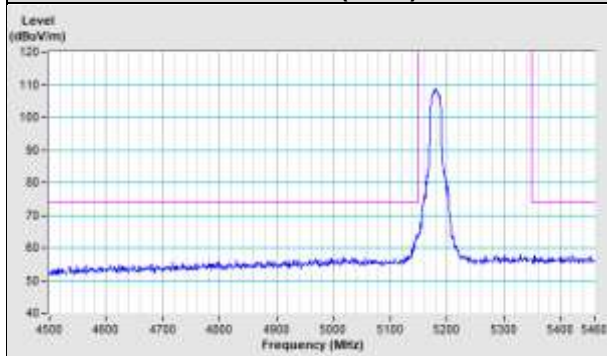

<b>Vertical (Peak)</b>	<b>Vertical (Average)</b>
------------------------	---------------------------

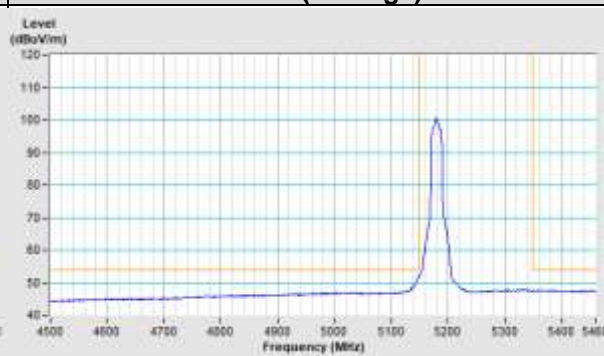
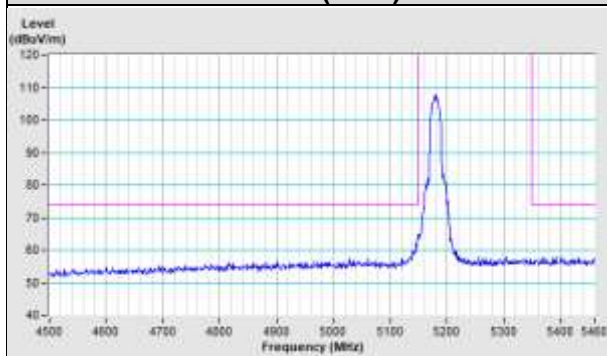

**802.11ac (VHT20) Channel 40**

<b>Horizontal (Peak)</b>	<b>Horizontal (Average)</b>
--------------------------	-----------------------------

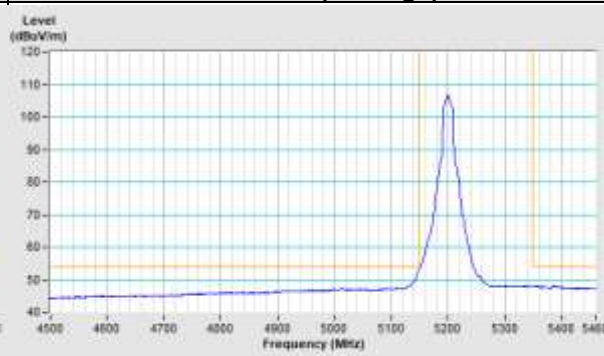
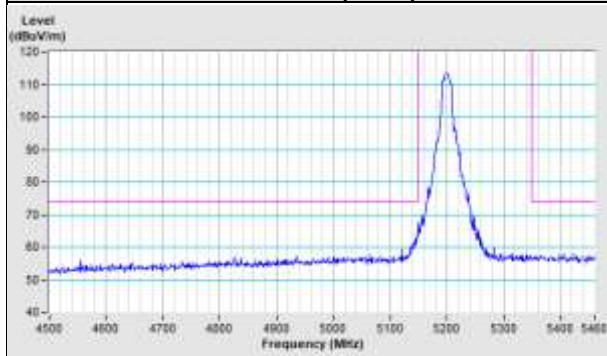

<b>Vertical (Peak)</b>	<b>Vertical (Average)</b>
------------------------	---------------------------

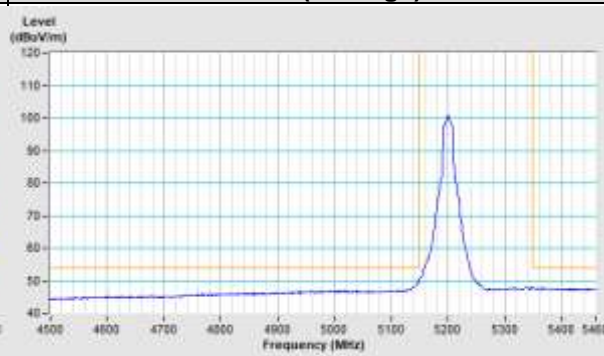
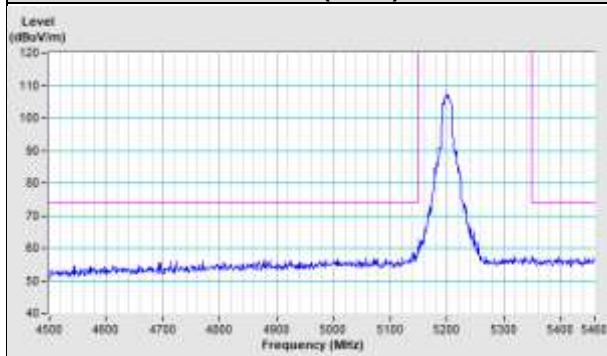

### 802.11ac (VHT20) Channel 48

**Horizontal (Peak)**

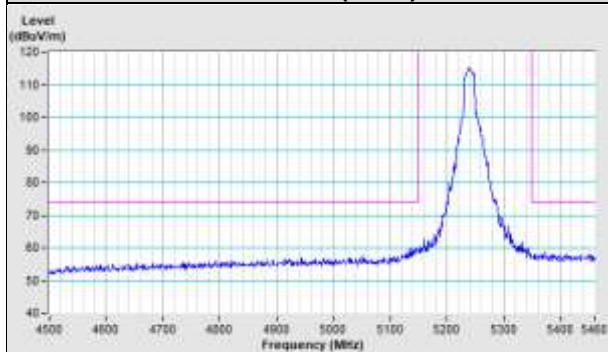

**Horizontal (Average)**

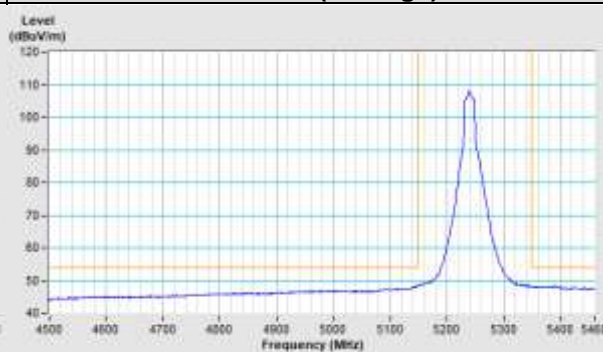

**Vertical (Peak)**

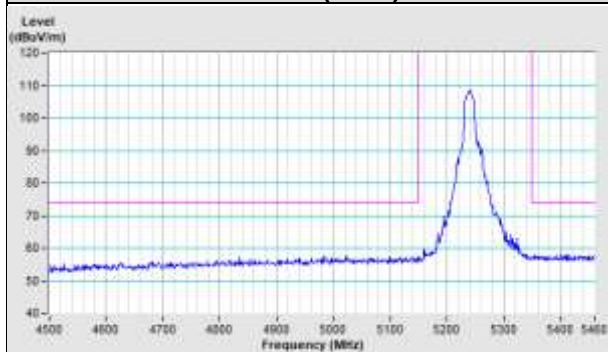

**Vertical (Average)**

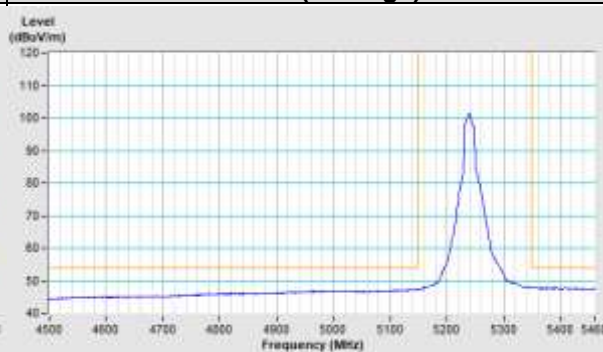

### 802.11ac (VHT40) Channel 38

**Horizontal (Peak)**

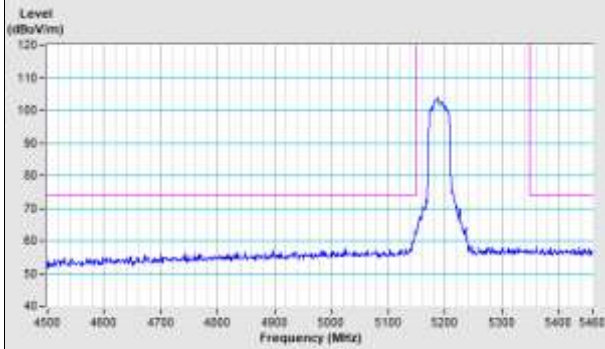

**Horizontal (Average)**

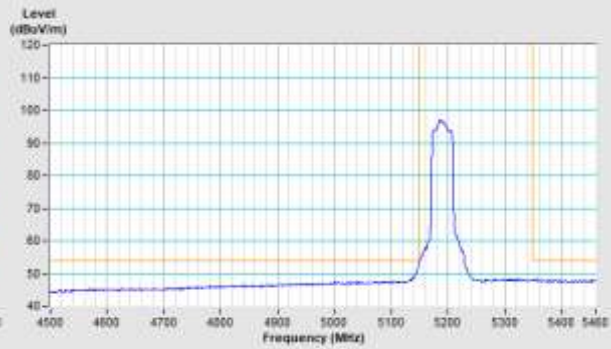

**Vertical (Peak)**

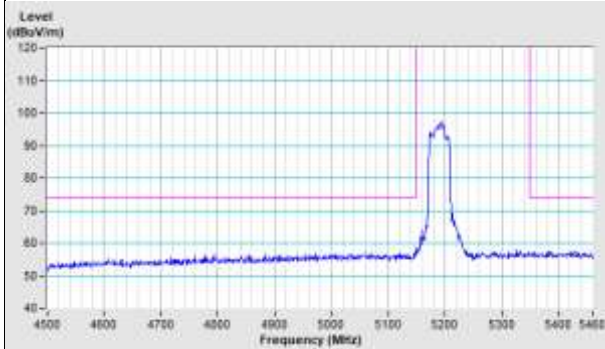

**Vertical (Average)**

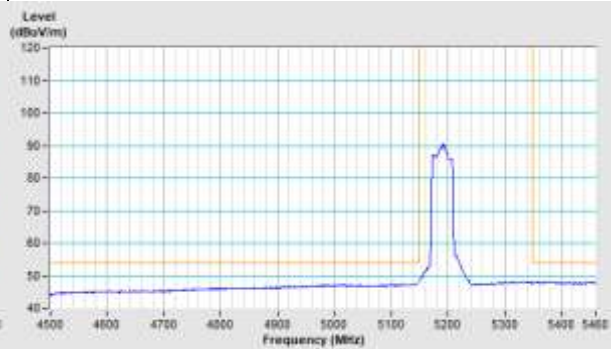

### 802.11ac (VHT40) Channel 46

**Horizontal (Peak)**

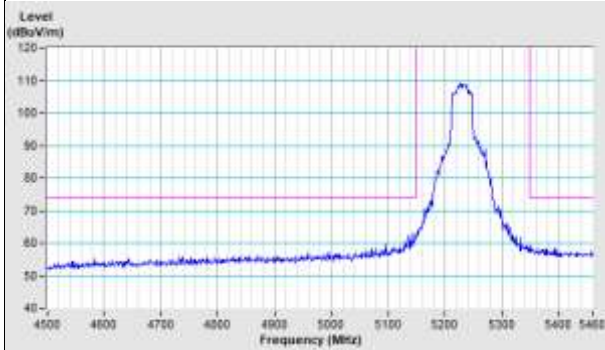

**Horizontal (Average)**

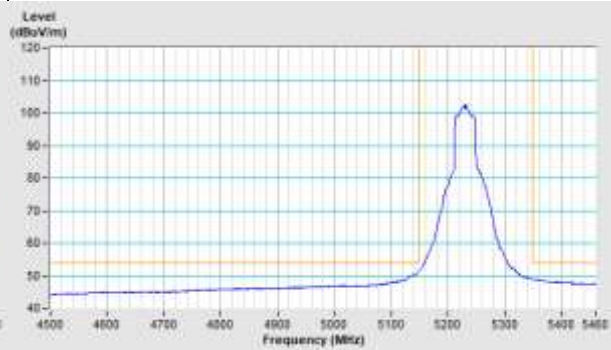

**Vertical (Peak)**

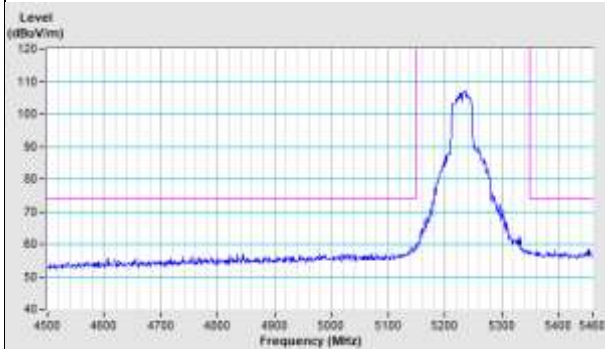

**Vertical (Average)**

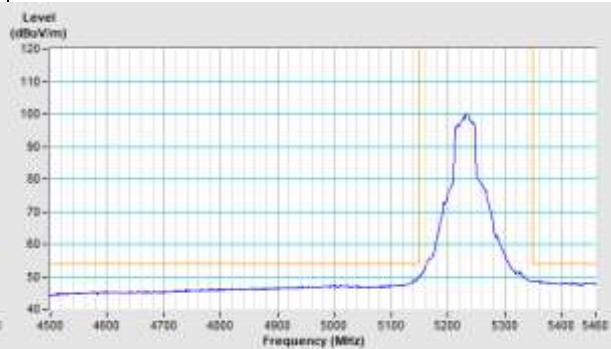



**802.11ac (VHT80) Channel 42**

**Horizontal (Peak)**

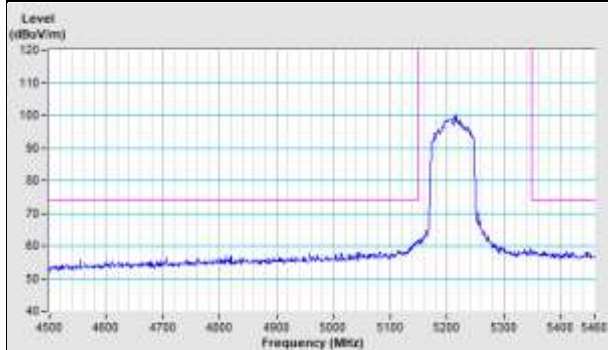

**Horizontal (Average)**

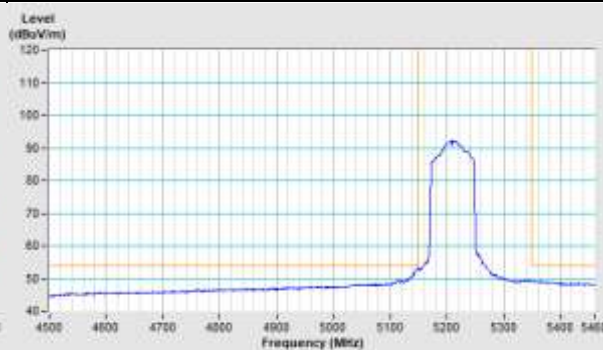

**Vertical (Peak)**

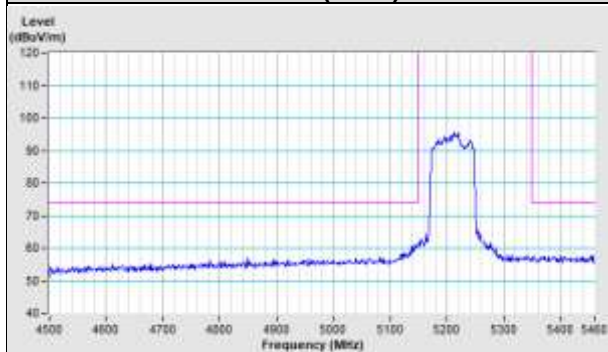

**Vertical (Average)**

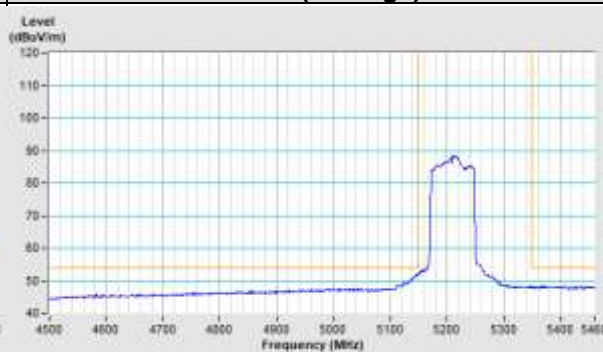

## Appendix – Information of the Testing Laboratories

We, Bureau Veritas Consumer Products Services (H.K.) Ltd., Taoyuan Branch, were founded in 1988 to provide our best service in EMC, Radio, Telecom and Safety consultation. Our laboratories are FCC recognized accredited test firms and accredited according to ISO/IEC 17025.

If you have any comments, please feel free to contact us at the following:

**Lin Kou EMC/RF Lab**

Tel: 886-2-26052180

Fax: 886-2-26051924

**Hsin Chu EMC/RF/Telecom Lab**

Tel: 886-3-6668565

Fax: 886-3-6668323

**Hwa Ya EMC/RF/Safety Lab**

Tel: 886-3-3183232

Fax: 886-3-3270892

**Email:** [service.adt@tw.bureauveritas.com](mailto:service.adt@tw.bureauveritas.com)

**Web Site:** [www.bureauveritas-adt.com](http://www.bureauveritas-adt.com)

The address and road map of all our labs can be found in our web site also.

--- END ---