

TEST REPORT

CERTIFICATE OF CONFORMITY

Standard: 47 CFR FCC Part 15, Subpart B, Class B
ANSI C63.4: 2014

Report No.: FDBEMI-WTW-P23040655

FCC ID: NOIKBN428

Product: Electronic Display Device

Brand: Rakuten kobo

Model No.: N428

Received Date: 2023/5/4

Test Date: 2023/9/19 ~ 2023/9/23

Issued Date: 2023/10/6

Applicant: NETRONIX, INC.

Address: No. 945, Boai St., Jubei City, Hsin-Chu, 30265, Taiwan

Issued By: Bureau Veritas Consumer Products Services (H.K.) Ltd., Taoyuan Branch
Hsin Chu Laboratory

Lab Address: E-2, No.1, Li Hsin 1st Road, Hsinchu Science Park, Hsinchu City 300, Taiwan

Test Location: No. 49, Ln. 206, Wende Rd., Shangshan Tsuen, Chiung Lin Hsiang, Hsin Chu Hsien 307,
Taiwan

FCC Registration /

Designation Number: 960022 / TW1058

Approved by: _____



Ken Lu / Manager

, Date: _____

2023/10/6

This test report consists of 24 pages in total. It may be duplicated completely for legal use with the approval of the applicant. It should not be reproduced except in full, without the written approval of our laboratory. The test results in the report only apply to the tested sample. The test results in this report are traceable to the national or international standards.



Prepared by : Phoebe Wang / Specialist

This report is governed by, and incorporates by reference, the Conditions of Testing as posted at the date of issuance of this report at <http://www.bureauveritas.com/home/about-us/our-business/cps/about-us/terms-conditions/>, and is intended for your exclusive use. Any copying or replication of this report to or for any other person or entity, or use of our name or trademark, is permitted only with our prior written permission. This report sets forth our findings solely with respect to the test samples identified herein. The results set forth in this report are not indicative or representative of the quality or characteristics of the lot from which a test sample was taken or any similar or identical product unless specifically and expressly noted. Our report includes all of the tests requested by you and the results thereof based upon the information that you provided to us. Measurement uncertainty is only provided upon request for accredited tests. Statements of conformity are based on simple acceptance criteria without taking measurement uncertainty into account, unless otherwise requested in writing. You have 60 days from date of issuance of this report to notify us of any material error or omission caused by our negligence or if you require measurement uncertainty; provided, however, that such notice shall be in writing and shall specifically address the issue you wish to raise. A failure to raise such issue within the prescribed time shall constitute your unqualified acceptance of the completeness of this report, the tests conducted and the correctness of the report contents.

Table of Contents

Release Control Record	3
1 Certificate.....	4
2 Summary of Test Results	5
2.1 Measurement Uncertainty	5
2.2 Supplementary Information	5
3 General Information	6
3.1 Description of EUT	6
3.2 Primary Clock Frequencies of Internal Source.....	6
3.3 Features of EUT	6
3.4 Operating Modes of EUT and Determination of Worst Case Operating Mode	7
3.5 Test Program Used and Operation Descriptions	8
3.6 Connection Diagram of EUT and Peripheral Devices	8
3.7 Configuration of Peripheral Devices and Cable Connections	8
4 Test Instruments	9
4.1 Conducted Emissions from Power Ports	9
4.2 Radiated Emissions up to 1 GHz	9
4.3 Radiated Emissions above 1 GHz.....	10
5 Limits of Test Items.....	11
5.1 Conducted Emissions from Power Ports	11
5.2 Radiated Emissions up to 1 GHz	11
5.3 Radiated Emissions above 1 GHz.....	11
6 Test Arrangements.....	12
6.1 Conducted Emissions from Power Ports	12
6.2 Radiated Emissions up to 1 GHz	13
6.3 Radiated Emissions above 1 GHz.....	14
7 Test Results of Test Item	15
7.1 Conducted Emissions from Power Ports	15
7.2 Radiated Emissions up to 1 GHz	17
7.3 Radiated Emissions above 1 GHz.....	19
8 Pictures of Test Arrangements	23
9 Information of the Testing Laboratories	24



Release Control Record

Issue No.	Description	Date Issued
FDBEMI-WTW-P23040655	Original release.	2023/10/6

1 Certificate

Product: Electronic Display Device

Brand: Rakuten kobo

Test Model: N428

Sample Status: Engineering sample

Applicant: NETRONIX, INC.

Test Date: 2023/9/19 ~ 2023/9/23

Standard: 47 CFR FCC Part 15, Subpart B, Class B
ANSI C63.4: 2014

The above equipment has been tested by **Bureau Veritas Consumer Products Services (H.K.) Ltd., Taoyuan Branch**, and found compliance with the requirement of the above standards. The test record, data evaluation & Equipment Under Test (EUT) configurations represented herein are true and accurate accounts of the measurements of the sample's EMC characteristics under the conditions specified in this report.

2 Summary of Test Results

The test items that the EUT need to perform in accordance with its interfaces, evaluated functions, are as follows:

Standard / Clause	Test Item	Result	Remark
FCC Part 15.107	Conducted Emissions from Power Ports	Pass	Minimum passing Class B margin is -17.25 dB at 0.58563 MHz
FCC Part 15.109	Radiated Emissions up to 1 GHz	Pass	Minimum passing Class B margin is -9.63 dB at 914.96 MHz
FCC Part 15.109	Radiated Emissions above 1 GHz	Pass	Minimum passing Class B margin is -4.03 dB at 17783.53 MHz

Note: Determining compliance based on the results of the compliance measurement, not taking into account measurement instrumentation uncertainty.

2.1 Measurement Uncertainty

Where relevant, the following measurement uncertainty levels have been estimated for tests performed on the EUT as specified in CISPR 16-4-2:

Measurement	Specification	Expanded Uncertainty (k=2) (±)	Maximum allowable uncertainty (±)
Conducted Emissions from Power Ports	150 kHz ~ 30 MHz	1.8 dB	3.4 dB (U_{CISPR})
Radiated Emissions up to 1 GHz	30 MHz ~ 1 GHz	5.8 dB	6.3 dB (U_{CISPR})
Radiated Emissions above 1 GHz	1 GHz ~ 6 GHz	4.85 dB	5.2 dB (U_{CISPR})
	6 GHz ~ 18 GHz	4.66 dB	5.5 dB (U_{CISPR})
	18 GHz ~ 40 GHz	5.07 dB	-

The other instruments specified are routine verified to remain within the calibrated levels, no measurement uncertainty is required to be calculated.

2.2 Supplementary Information

There is not any deviation from the test standards for the test method, and no modifications required for compliance.

3 General Information

3.1 Description of EUT

Product	Electronic Display Device
Brand	Rakuten kobo
Test Model	N428
Sample Status	Engineering sample
Operating Software	N/A
Power Supply Rating	5 Vdc from USB interface or 3.87 Vdc from battery
Accessory Device	N/A
Data Cable Supplied	Refer to Note

Note:

1. The EUT could be supplied with USB cable and following different models could be chosen:

Brand	Model	material	Color	Remark
Yih Fone	SH-0418	TPE	Black	Shieled:Y, 1.0M, Core:N/A
	SH-0420		White	

2. The EUT has different colors as below table:

No.	Model	Color	Description
1	N428	Black	only the color is different, the circuit design is the same.
2		White	

3. The EUT has two eMMC as below table:

No.	Model	Remark
1	PTE7A0YJ-32GE	1st source eMMC
2	MKEMF032GT1E-C	2nd source eMMC

3.2 Primary Clock Frequencies of Internal Source

The highest frequency generated or used within the EUT or on which the EUT operates or tunes is 5850 MHz, provided by NETRONIX, INC., for detailed internal source, please refer to the manufacturer's specifications.

3.3 Features of EUT

The tests reported herein were performed according to the method specified by NETRONIX, INC., for detailed feature description, please refer to the manufacturer's specifications or user's manual.

3.4 Operating Modes of EUT and Determination of Worst Case Operating Mode

The EUT has been pre-tested under following test modes.

Test Condition	
Mode	Radiated Emissions up to 1 GHz
1	1st source eMMC+USB Mode(Yih Fone) + Input Power(5 Vdc from host)
2	2st source eMMC+USB Mode(Yih Fone) + Input Power(5 Vdc from host)
3	1st source eMMC+WiFi 2.4G+BT + Input Power(3.87 Vdc from battery)
4	1st source eMMC+WiFi 5G+BT + Input Power(3.87 Vdc from battery)

Note: The worst case is that mode 1 is shown in bold.

Test modes are presented in the report as below.

Test Condition	
Mode	Conducted Emissions from Power Ports
A	1st source eMMC+USB Mode(Yih Fone) + Input Power(5 Vdc from host)
Mode	Radiated Emissions up to 1 GHz
A	1st source eMMC+USB Mode(Yih Fone) + Input Power(5 Vdc from host)
Mode	Radiated Emissions above 1 GHz
A	1st source eMMC+USB Mode(Yih Fone) + Input Power(5 Vdc from host)

3.5 Test Program Used and Operation Descriptions

1. Turn on the power of all equipment.
2. EUT is charging from support unit A (Laptop) via USB Type A to C cable.
3. Support unit A (Laptop) reads and writes messages from EUT via USB Type A to C cable.
4. Support unit A (Laptop) runs “EMC test.exe” then sends “H” messages to itself.

3.6 Connection Diagram of EUT and Peripheral Devices

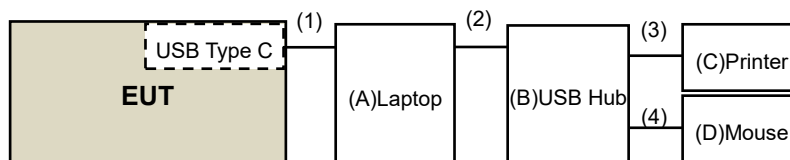

3.7 Configuration of Peripheral Devices and Cable Connections

ID	Product	Brand	Model No.	Serial No.	FCC ID	Remarks
A	Laptop	DELL	Latitude 5420	7YX61F3	FCC DOC	Provided by Lab
B	USB HUB	e-SENSE	01-ELS647	N/A	N/A	Provided by Lab
C	Printer	EPSON	LQ-300+II	G88Y074085	FCC DOC	Provided by Lab
D	Mouse	Logitech	M-U0026	810-002182_002	N/A	Provided by Lab

ID	Cable Descriptions	Qty.	Length (m)	Shielding (Yes/No)	Cores (Qty.)	Remarks
1	USB Type A to C cable	1	1	Yes	0	Provided by Applicant
2	USB Type A cable	1	0.15	Yes	0	Provided by Lab
3	USB Type A to B cable	1	1.8	Yes	0	Provided by Lab
4	USB Type A cable	1	1.8	Yes	0	Provided by Lab

4 Test Instruments

The calibration interval of the all test instruments are 12 months and the calibrations are traceable to NML/ROC and NIST/USA.

4.1 Conducted Emissions from Power Ports

Description Manufacturer	Model No.	Serial No.	Calibrated Date	Calibrated Until
50 ohm terminal resistance	N/A	EMC-02	2022/9/27	2023/9/26
		EMC-03	2022/9/27	2023/9/26
EMI Test Receiver R&S	ESR3	102982	2023/5/25	2024/5/24
Fixed Attenuator STI	STI02-2200-10	006	2023/7/1	2024/6/30
LISN R&S	ENV216	100072	2023/7/7	2024/7/6
LISN Schwarzbeck	NNLK 8121	0809	2023/3/14	2024/3/13
	NSLK 8127	8127-522	2023/9/12	2024/9/11
RF Coaxial Cable JYBAO	5D-FB	COACAB-002	2023/7/1	2024/6/30
Software BV	BVADT_Cond_ V7.3.7.4	N/A	N/A	N/A

Notes:

1. The test was performed in HC - Conduction 3.
2. The VCCI Shielded room C Registration No. is C-13611.
3. Tested Date: 2023/9/23

4.2 Radiated Emissions up to 1 GHz

Description Manufacturer	Model No.	Serial No.	Calibrated Date	Calibrated Until
Antenna Tower & Turn Table CT	N/A	N/A	N/A	N/A
Bi_Log Antenna Schwarzbeck	VULB 9168	9168-360	2022/10/21	2023/10/20
Fixed Attenuator MVE	MVE2252-05	MVE2252-05-001	2023/9/7	2024/9/6
MXE EMI Receiver Agilent	N9038A	MY51210105	2023/6/7	2024/6/6
Preamplifier Mini-Circuits	ZFL-1000VH2B	AMP-ZFL-03	2023/9/7	2024/9/6
RF Coaxial Cable	RF-141	CHGCAB-004	2023/9/7	2024/9/6
RF Coaxial Cable PEWC	8D	CHGCAB-005	2023/9/7	2024/9/6
	8D-FB	CHGCAB-001-2	2023/9/7	2024/9/6
Software BV	ADT_Radiated_V8.7.08	N/A	N/A	N/A

Notes:

1. The test was performed in HC - 966 chamber 1. The test site validated date: 2023/5/13 (NSA)
2. The VCCI Site Registration No. is R-20009.
3. Tested Date: 2023/9/19

4.3 Radiated Emissions above 1 GHz

Description Manufacturer	Model No.	Serial No.	Calibrated Date	Calibrated Until
Antenna Tower & Turn Table CT	N/A	N/A	N/A	N/A
Fix tool for Boresight BV	BAF-01	5	N/A	N/A
Horn Antenna FT-RF	HA-07M18G-NF	0000320091110	2022/11/13	2023/11/12
Horn Antenna Schwarzbeck	BBHA 9170	9170-424	2022/11/13	2023/11/12
MXA Signal Analyzer Keysight	N9020B	MY60112816	2023/5/17	2024/5/16
MXE EMI Receiver Agilent	N9038A	MY51210105	2023/6/7	2024/6/6
Preamplifier Agilent	8449B	3008A02578	2023/6/1	2024/5/31
Preamplifier EMCI	EMC118A45SE	980817	2023/8/12	2024/8/11
	EMC184045SE	980770	2023/6/1	2024/5/31
RF Coaxial Cable EMCI	EMC101G-KM-KM-4000	210707	2022/11/4	2023/11/3
	EMC104-SM-SM-2000	181208	2023/8/12	2024/8/11
	EMC104-SM-SM-6000	181209	2023/8/12	2024/8/11
	EMC104-SM-SM-8500	181211	2023/8/12	2024/8/11
RF Coaxial Cable SUHNER	SUCOFLEX 102	36432/2	2022/12/10	2023/12/9
Software BV	ADT_Radiated_V8.7.08	N/A	N/A	N/A

Notes:

1. The test was performed in HC - 966 chamber 1. The test site validated date: 2023/8/12 (VSWR)
2. The VCCI Site Registration No. is G-10137.
3. Tested Date: 2023/9/19 ~ 2023/9/22

5 Limits of Test Items

5.1 Conducted Emissions from Power Ports

Frequency (MHz)	Class A (dBuV)		Class B (dBuV)	
	Quasi-peak	Average	Quasi-peak	Average
0.15 - 0.5	79	66	66 - 56	56 - 46
0.50 - 5.0	73	60	56	46
5.0 - 30.0	73	60	60	50

Notes: 1. The lower limit shall apply at the transition frequencies.
 2. The limit decreases linearly with the logarithm of the frequency in the range of 0.15 to 0.50 MHz.

5.2 Radiated Emissions up to 1 GHz

Emissions radiated outside of the specified bands, shall be according to the general radiated limits as following:

Radiated Emissions Limits at 10 meters (dB μ V/m)				
Frequencies (MHz)	FCC 15B, Class A	FCC 15B, Class B	CISPR 22, Class A	CISPR 22, Class B
30-88	39.1	29.5	40	30
88-216	43.5	33.1		
216-230	46.4	35.6		
230-960				
960-1000	49.5	43.5	47	37

Radiated Emissions Limits at 3 meters (dB μ V/m)				
Frequencies (MHz)	FCC 15B, Class A	FCC 15B, Class B	CISPR 22, Class A	CISPR 22, Class B
30-88	49.5	40.0	50.5	40.5
88-216	54.0	43.5		
216-230	56.9	46.0		
230-960				
960-1000	60.0	54.0	57.5	47.5

Notes: 1. The lower limit shall apply at the transition frequencies.

5.3 Radiated Emissions above 1 GHz

Frequency Range (For unintentional radiators)

Highest frequency generated or used in the device or on which the device operates or tunes (MHz)	Upper frequency of measurement range (MHz)
Below 1.705	30
1.705-108	1000
108-500	2000
500-1000	5000
Above 1000	5th harmonic of the highest frequency or 40GHz, whichever is lower

Radiated Emissions Limits at 3 meters (dB μ V/m)		
Frequency range	Class A	Class B
Above 1GHz	Avg: 60 Peak: 80	Avg: 54 Peak: 74

Notes: 1. These limit levels apply for a measurement distance of 3 m. If using a different measurement distance, the measured levels shall be extrapolated to the 3 m limit distance using a factor of 20 dB per decade of distance. The measurement distance shall place the measurement antenna in the far field of the ITE or digital apparatus under test.

6 Test Arrangements

6.1 Conducted Emissions from Power Ports

- For the table-top EUT is placed on a 0.8 meter insulation table; for the floor standing EUT shall be insulated (by insulation of 12 mm) from the horizontal reference ground plane. The EUT is placed 0.4 meters from the conducting wall of the shielded room with EUT being connected to the power mains through a line impedance stabilization network (LISN). Other support units are connected to the power mains through another LISN. They provide coupling impedance for the measuring instrument.
- Both lines of the power mains connected to the EUT were checked for maximum conducted interference.
- The test results of conducted emissions at mains ports are recorded of six worst margins for quasi-peak (mandatory) [and average (if necessary)] values against the limits at frequencies of interest unless the margin is 20 dB or greater.

Note: The resolution bandwidth and video bandwidth of test receiver is 9kHz for quasi-peak detection (QP) and average detection (AV) at frequency 0.15MHz-30MHz.

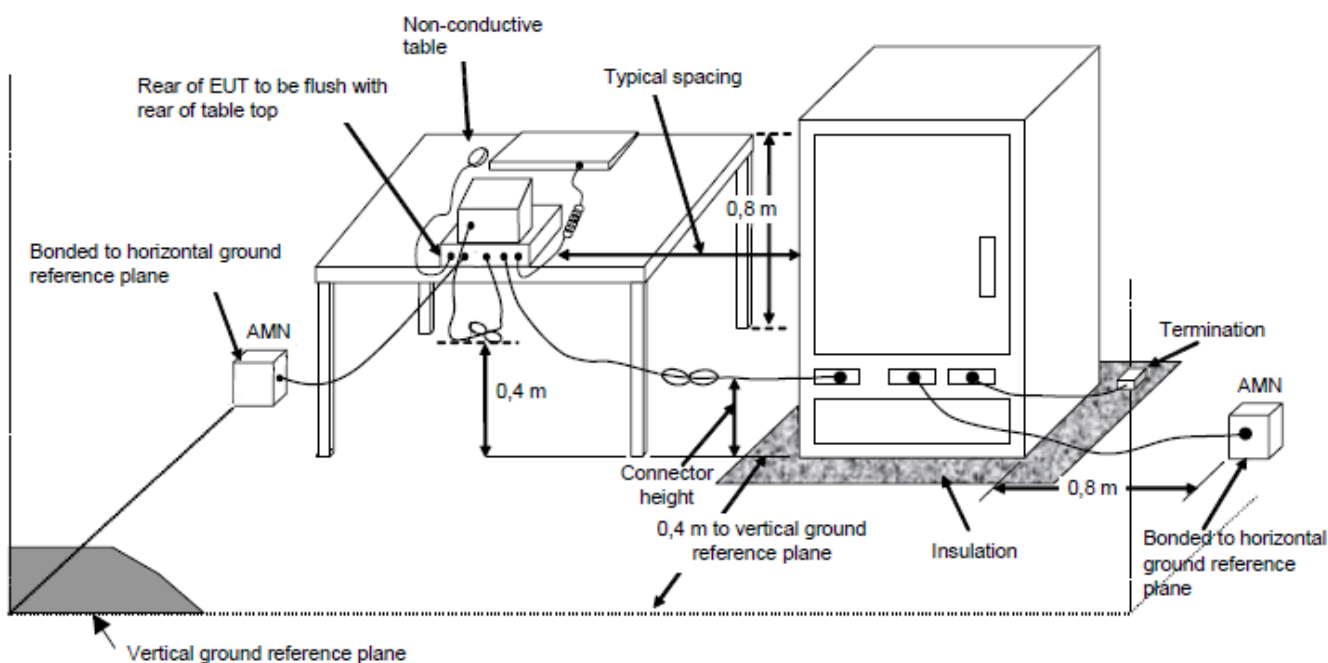

For the actual test configuration, please refer to the related Item – Photographs of the Test Configuration.

6.2 Radiated Emissions up to 1 GHz

- a. For the table-top EUT is placed on a 0.8 meter to the top of rotating table; for the floor standing EUT shall be insulated (by insulation of 12 mm) from the horizontal reference ground plane. The rotating table is rotated 360 degrees to determine the position of the highest radiation. If the equipment requires a dedicated ground connection, this shall be provided and bonded to the RGP.
- b. The EUT was set 3 meters away from the interference-receiving antenna, which was mounted on the top of a variable-height antenna tower.
- c. The antenna is a broadband antenna, and its height is varied from one meter to four meters above the ground to determine the maximum value of the field strength. Both horizontal and vertical polarizations of the antenna are set to make the measurement.
- d. For each suspected emission, the EUT was arranged to its worst case and then the antenna was tuned to heights from 1 meter to 4 meters and the rotatable table was turned from 0 degrees to 360 degrees to find the maximum reading.
- e. The test-receiver system was set to quasi-peak detect function and specified bandwidth with maximum hold mode when the test frequency is up to 1 GHz.

Note: The resolution bandwidth and video bandwidth of test receiver/spectrum analyzer is 120kHz for quasi-peak detection (QP) at frequency up to 1GHz.

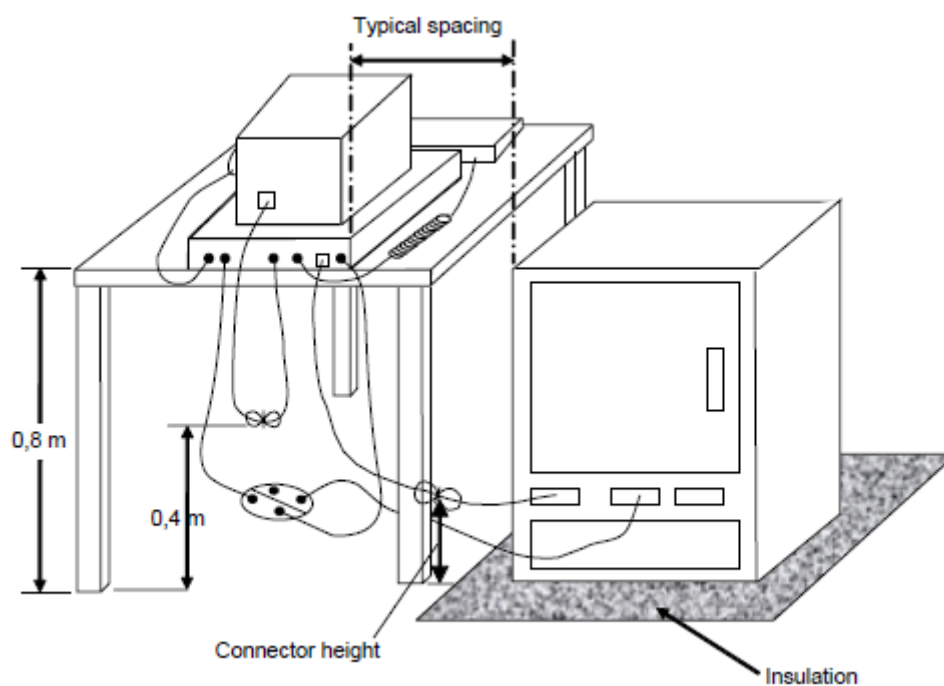

For the actual test configuration, please refer to the related Item – Photographs of the Test Configuration.

6.3 Radiated Emissions above 1 GHz

- For the table-top EUT is placed on a 0.8 meter to the top of rotating table; for the floor standing EUT shall be insulated (by insulation of 12 mm) from the horizontal reference ground plane. The rotating table is rotated 360 degrees to determine the position of the highest radiation. If the equipment requires a dedicated ground connection, this shall be provided and bonded to the RGP.
- The EUT was set $d = 3$ meters away from the interference-receiving antenna, which was mounted on the top of a variable-height antenna tower.
- The height of antenna can be varied from one meter to four meters, the height of adjustment depends on the EUT height and the antenna 3dB beamwidth both, to detect the maximum value of the field strength. Both horizontal and vertical polarizations of the antenna are set to make the measurement.
- For each suspected emission, the EUT was arranged to its worst case and then the antenna was tuned to heights and the rotatable table was turned from 0 degrees to 360 degrees to find the maximum reading.
- The spectrum analyzer system was set to peak and average detects function and specified bandwidth with maximum hold mode when the test frequency is above 1 GHz.

Note: The resolution bandwidth of test receiver/spectrum analyzer is 1MHz and video bandwidth is 3MHz for Peak detection (PK) at frequency above 1GHz. The resolution bandwidth of test receiver/spectrum analyzer is 1 MHz for Average detection (AV) at frequency above 1GHz.

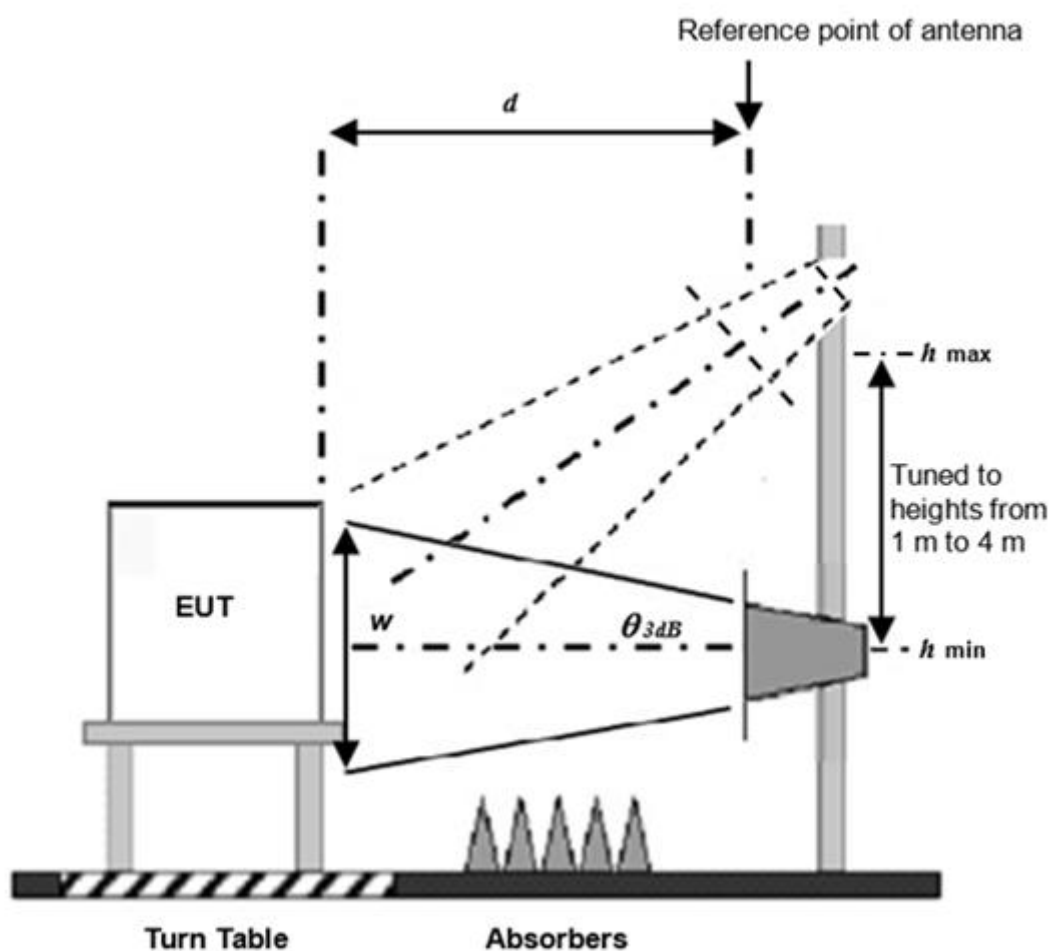

For the actual test configuration, please refer to the related item – Photographs of the Test Configuration.

7 Test Results of Test Item

7.1 Conducted Emissions from Power Ports

Mode A

Frequency Range	150 kHz ~ 30 MHz	Detector Function & Resolution Bandwidth	Quasi-Peak (QP) / Average (AV), 9kHz
Input Power	5 Vdc from host	Environmental Conditions	26°C, 62% RH
Tested by	Nick Lo		

Phase Of Power : Line (L)										
No	Frequency (MHz)	Correction Factor (dB)	Reading Value (dBuV)		Emission Level (dBuV)		Limit (dBuV)		Margin (dB)	
			Q.P.	AV.	Q.P.	AV.	Q.P.	AV.	Q.P.	AV.
1	0.15400	10.17	37.38	22.16	47.55	32.33	65.78	55.78	-18.23	-23.45
2	0.17800	10.17	32.00	16.70	42.17	26.87	64.58	54.58	-22.41	-27.71
3	0.21000	10.17	29.27	13.35	39.44	23.52	63.21	53.21	-23.77	-29.69
4	0.22985	10.17	25.87	11.68	36.04	21.85	62.46	52.46	-26.42	-30.61
5	0.26600	10.17	23.98	7.59	34.15	17.76	61.24	51.24	-27.09	-33.48
6	0.58600	10.16	24.81	18.09	34.97	28.25	56.00	46.00	-21.03	-17.75
7	13.05000	10.61	23.29	16.46	33.90	27.07	60.00	50.00	-26.10	-22.93

Remarks:

1. Q.P. and AV. are abbreviations of quasi-peak and average individually.
2. The emission levels of other frequencies were very low against the limit.
3. Margin value = Emission level – Limit value
4. Correction factor = Insertion loss + Cable loss
5. Emission Level = Correction Factor + Reading Value

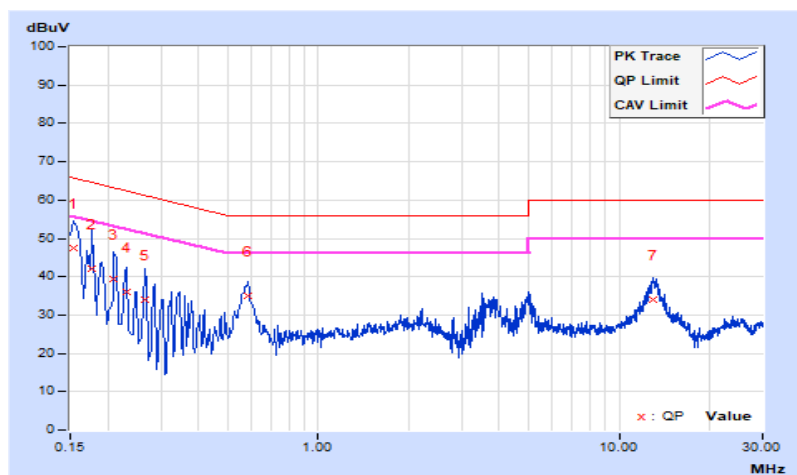

Frequency Range	150 kHz ~ 30 MHz	Detector Function & Resolution Bandwidth	Quasi-Peak (QP) / Average (AV), 9kHz
Input Power	5 Vdc from host	Environmental Conditions	26°C, 62% RH
Tested by	Nick Lo		

Phase Of Power : Neutral (N)										
No	Frequency (MHz)	Correction Factor (dB)	Reading Value (dBuV)		Emission Level (dBuV)		Limit (dBuV)		Margin (dB)	
			Q.P.	AV.	Q.P.	AV.	Q.P.	AV.	Q.P.	AV.
1	0.15400	10.19	36.70	22.56	46.89	32.75	65.78	55.78	-18.89	-23.03
2	0.17400	10.19	33.12	16.70	43.31	26.89	64.77	54.77	-21.46	-27.88
3	0.19780	10.18	29.35	12.76	39.53	22.94	63.70	53.70	-24.17	-30.76
4	0.25000	10.18	24.45	8.31	34.63	18.49	61.76	51.76	-27.13	-33.27
5	0.31000	10.17	19.95	5.94	30.12	16.11	59.97	49.97	-29.85	-33.86
6	0.58563	10.17	25.53	18.58	35.70	28.75	56.00	46.00	-20.30	-17.25
7	13.25000	10.60	21.40	13.45	32.00	24.05	60.00	50.00	-28.00	-25.95

Remarks:

1. Q.P. and AV. are abbreviations of quasi-peak and average individually.
2. The emission levels of other frequencies were very low against the limit.
3. Margin value = Emission level – Limit value
4. Correction factor = Insertion loss + Cable loss
5. Emission Level = Correction Factor + Reading Value

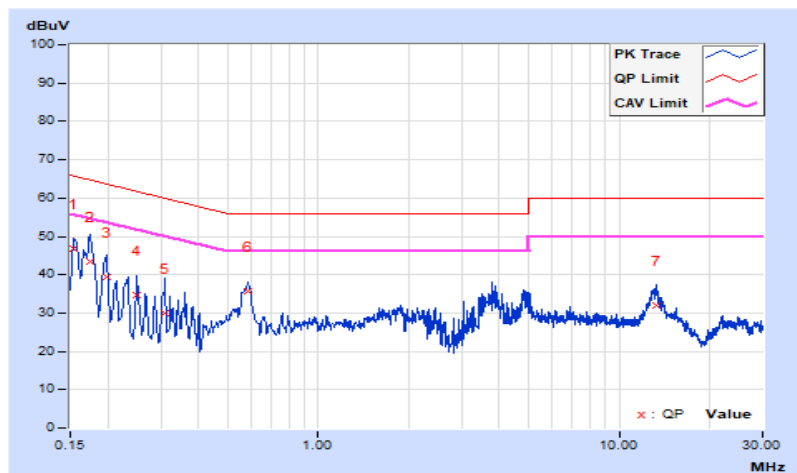

7.2 Radiated Emissions up to 1 GHz

Mode A

Frequency Range	30 MHz ~ 1 GHz	Detector Function & Resolution Bandwidth	Quasi-Peak (QP), 120 kHz
Input Power	5 Vdc from host	Environmental Conditions	28°C, 80% RH
Tested By	Eagle Chen		

Antenna Polarity & Test Distance : Horizontal at 3 m

No	Frequency (MHz)	Emission Level (dBuV/m)	Limit (dBuV/m)	Margin (dB)	Antenna Height (m)	Table Angle (Degree)	Raw Value (dBuV)	Correction Factor (dB/m)
1	58.49	20.14 QP	40.00	-19.86	3.00 H	360	28.93	-8.79
2	183.03	20.23 QP	43.50	-23.27	2.00 H	255	30.08	-9.85
3	708.26	27.86 QP	46.00	-18.14	1.00 H	27	25.89	1.97
4	832.22	33.57 QP	46.00	-12.43	1.00 H	265	29.28	4.29
5	874.48	30.93 QP	46.00	-15.07	3.00 H	340	26.20	4.73
6	958.42	32.17 QP	46.00	-13.83	2.00 H	209	25.81	6.36

Remarks:

1. Emission Level(dBuV/m) = Raw Value(dBuV) + Correction Factor(dB/m)
2. Correction Factor(dB/m) = Antenna Factor (dB/m) + Cable Factor (dB) – Pre-Amplifier Factor (dB)
3. Margin value = Emission level – Limit value
4. The other emission levels were very low against the limit.

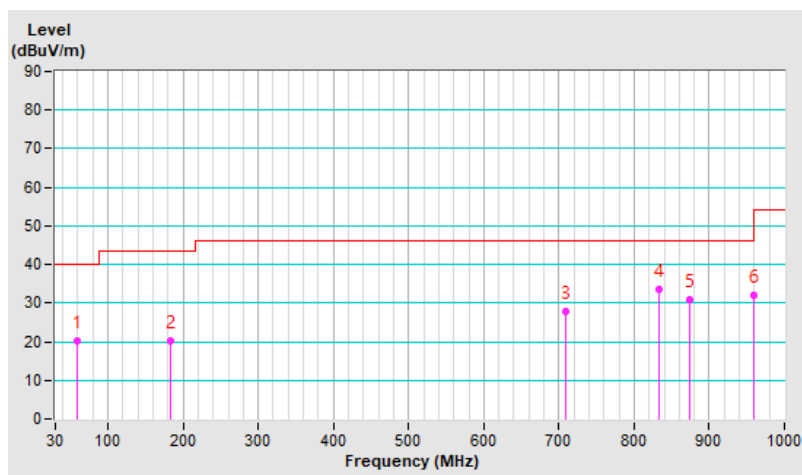

Frequency Range	30 MHz ~ 1 GHz	Detector Function & Resolution Bandwidth	Quasi-Peak (QP), 120 kHz
Input Power	5 Vdc from host	Environmental Conditions	28°C, 80% RH
Tested By	Eagle Chen		

Antenna Polarity & Test Distance : Vertical at 3 m								
No	Frequency (MHz)	Emission Level (dBuV/m)	Limit (dBuV/m)	Margin (dB)	Antenna Height (m)	Table Angle (Degree)	Raw Value (dBuV)	Correction Factor (dB/m)
1	53.02	25.97 QP	40.00	-14.03	2.00 V	105	34.25	-8.28
2	117.85	26.69 QP	43.50	-16.81	2.00 V	360	36.89	-10.20
3	179.83	26.13 QP	43.50	-17.37	1.00 V	65	35.66	-9.53
4	206.09	23.91 QP	43.50	-19.59	1.00 V	283	34.99	-11.08
5	704.31	32.62 QP	46.00	-13.38	2.00 V	65	30.69	1.93
6	914.96	36.37 QP	46.00	-9.63	2.00 V	360	30.43	5.94

Remarks:

1. Emission Level(dBuV/m) = Raw Value(dBuV) + Correction Factor(dB/m)
2. Correction Factor(dB/m) = Antenna Factor (dB/m) + Cable Factor (dB) – Pre-Amplifier Factor (dB)
3. Margin value = Emission level – Limit value
4. The other emission levels were very low against the limit.

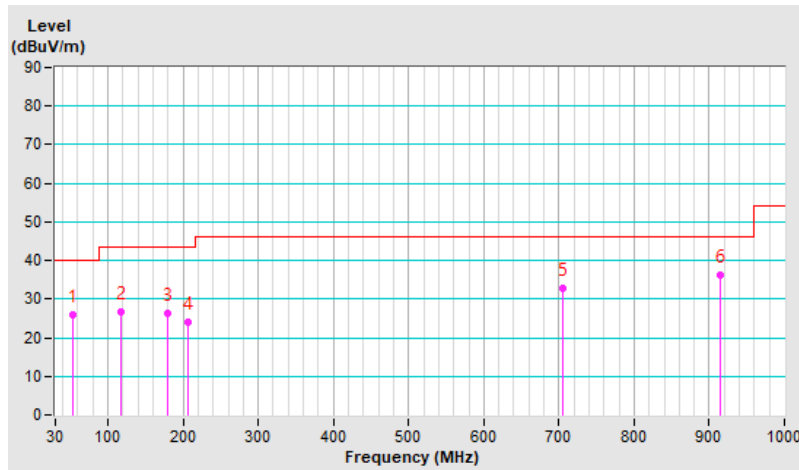

7.3 Radiated Emissions above 1 GHz

Mode A

Frequency Range	1 GHz ~ 18 GHz	Detector Function & Resolution Bandwidth	Peak (PK) / Average (AV), 1MHz
Input Power	5 Vdc from host	Environmental Conditions	27°C, 78% RH
Tested By	Eagle Chen		

Antenna Polarity & Test Distance : Horizontal at 3 m								
No	Frequency (MHz)	Emission Level (dBuV/m)	Limit (dBuV/m)	Margin (dB)	Antenna Height (m)	Table Angle (Degree)	Raw Value (dBuV)	Correction Factor (dB/m)
1	4167.67	43.99 PK	74.00	-30.01	1.50 H	267	40.90	3.09
2	4167.67	30.49 AV	54.00	-23.51	1.50 H	267	27.40	3.09
3	6715.97	51.61 PK	74.00	-22.39	2.00 H	356	39.48	12.13
4	6715.97	38.30 AV	54.00	-15.70	1.75 H	356	26.17	12.13
5	10462.77	51.15 PK	74.00	-22.85	1.00 H	302	39.01	12.14
6	10462.77	38.59 AV	54.00	-15.41	1.00 H	360	26.45	12.14
7	12442.13	54.02 PK	74.00	-19.98	1.00 H	126	39.18	14.84
8	12442.13	41.65 AV	54.00	-12.35	1.23 H	5	26.81	14.84
9	15215.97	56.62 PK	74.00	-17.38	2.00 H	0	39.78	16.84
10	15215.97	44.03 AV	54.00	-9.97	1.75 H	62	27.19	16.84
11	17783.53	62.67 PK	74.00	-11.33	2.00 H	304	39.44	23.23
12	17783.53	49.97 AV	54.00	-4.03	1.76 H	0	26.74	23.23

Remarks:

- Emission Level(dBuV/m) = Raw Value(dBuV) + Correction Factor(dB/m)
- Correction Factor(dB/m) = Antenna Factor (dB/m) + Cable Factor (dB)
– Pre-Amplifier Factor (dB)
- Margin value = Emission level – Limit value
- The other emission levels were very low against the limit.

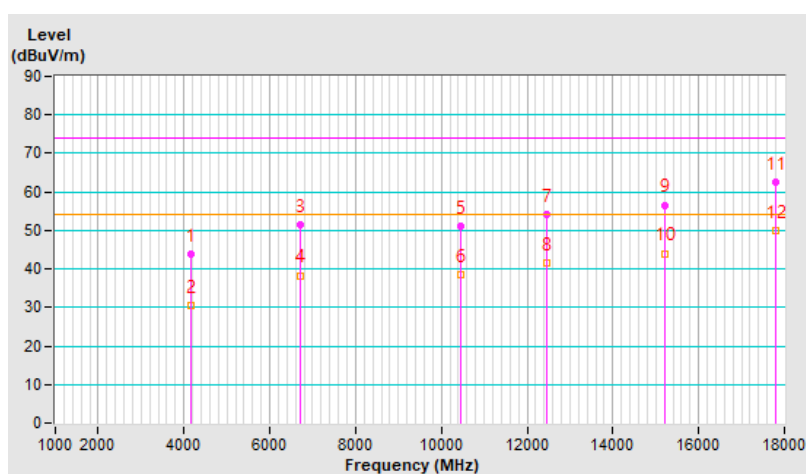

Frequency Range	1 GHz ~ 18 GHz	Detector Function & Resolution Bandwidth	Peak (PK) / Average (AV), 1MHz
Input Power	5 Vdc from host	Environmental Conditions	27°C, 78% RH
Tested By	Eagle Chen		

Antenna Polarity & Test Distance : Vertical at 3 m								
No	Frequency (MHz)	Emission Level (dBuV/m)	Limit (dBuV/m)	Margin (dB)	Antenna Height (m)	Table Angle (Degree)	Raw Value (dBuV)	Correction Factor (dB/m)
1	4953.63	47.56 PK	74.00	-26.44	1.50 V	194	41.74	5.82
2	4953.63	32.84 AV	54.00	-21.16	1.30 V	44	27.02	5.82
3	7033.87	52.33 PK	74.00	-21.67	2.00 V	360	39.78	12.55
4	7033.87	38.80 AV	54.00	-15.20	1.90 V	360	26.25	12.55
5	9040.43	50.91 PK	74.00	-23.09	2.00 V	360	41.01	9.90
6	9040.43	37.11 AV	54.00	-16.89	2.00 V	360	27.21	9.90
7	11763.83	53.41 PK	74.00	-20.59	2.00 V	158	40.07	13.34
8	11763.83	39.93 AV	54.00	-14.07	2.00 V	158	26.59	13.34
9	14448.70	57.02 PK	74.00	-16.98	1.00 V	360	40.21	16.81
10	14448.70	43.25 AV	54.00	-10.75	1.06 V	16	26.44	16.81
11	17679.83	61.82 PK	74.00	-12.18	1.50 V	115	38.99	22.83
12	17679.83	49.82 AV	54.00	-4.18	1.52 V	115	26.99	22.83

Remarks:

1. Emission Level(dBuV/m) = Raw Value(dBuV) + Correction Factor(dB/m)
2. Correction Factor(dB/m) = Antenna Factor (dB/m) + Cable Factor (dB) – Pre-Amplifier Factor (dB)
3. Margin value = Emission level – Limit value
4. The other emission levels were very low against the limit.

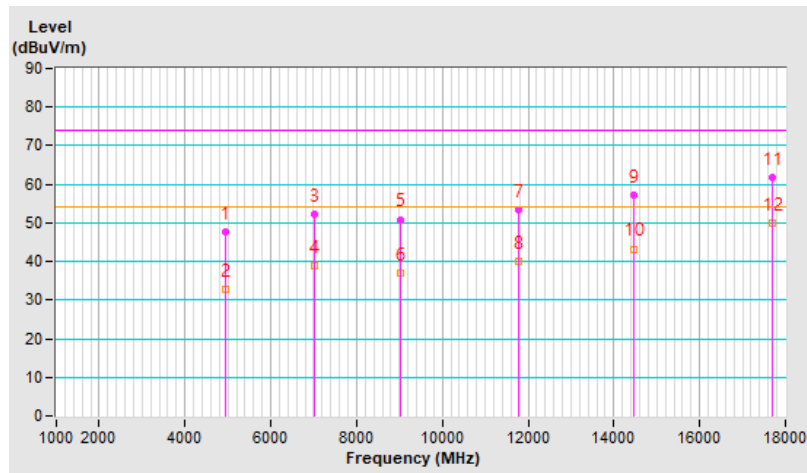

Frequency Range	18 GHz ~ 40 GHz	Detector Function & Resolution Bandwidth	Peak (PK) / Average (AV), 1MHz
Input Power	5 Vdc from host	Environmental Conditions	27°C, 78% RH
Tested By	Jet Chien		

Antenna Polarity & Test Distance : Horizontal at 3 m								
No	Frequency (MHz)	Emission Level (dBuV/m)	Limit (dBuV/m)	Margin (dB)	Antenna Height (m)	Table Angle (Degree)	Raw Value (dBuV)	Correction Factor (dB/m)
1	19753.40	57.15 PK	74.00	-16.85	1.50 H	71	55.35	1.80
2	19753.40	45.72 AV	54.00	-8.28	1.24 H	169	43.92	1.80
3	24236.27	58.95 PK	74.00	-15.05	1.50 H	360	56.96	1.99
4	24236.27	45.77 AV	54.00	-8.23	1.53 H	360	43.78	1.99
5	28963.33	59.28 PK	74.00	-14.72	1.50 H	360	57.67	1.61
6	28963.33	46.64 AV	54.00	-7.36	1.49 H	360	45.03	1.61

Remarks:

1. Emission Level(dBuV/m) = Raw Value(dBuV) + Correction Factor(dB/m)
2. Correction Factor(dB/m) = Antenna Factor (dB/m) + Cable Factor (dB) – Pre-Amplifier Factor (dB)
3. Margin value = Emission level – Limit value
4. The other emission levels were very low against the limit.

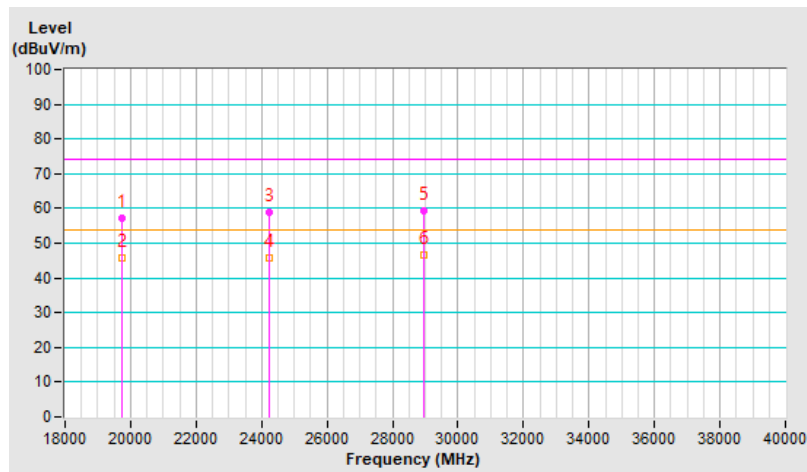

Frequency Range	18 GHz ~ 40 GHz	Detector Function & Resolution Bandwidth	Peak (PK) / Average (AV), 1MHz
Input Power	5 Vdc from host	Environmental Conditions	27°C, 78% RH
Tested By	Jet Chien		

Antenna Polarity & Test Distance : Vertical at 3 m								
No	Frequency (MHz)	Emission Level (dBuV/m)	Limit (dBuV/m)	Margin (dB)	Antenna Height (m)	Table Angle (Degree)	Raw Value (dBuV)	Correction Factor (dB/m)
1	19744.60	58.53 PK	74.00	-15.47	1.50 V	360	55.90	2.63
2	19744.60	45.73 AV	54.00	-8.27	1.49 V	360	43.10	2.63
3	24286.87	59.01 PK	74.00	-14.99	2.00 V	41	57.14	1.87
4	24286.87	45.84 AV	54.00	-8.16	1.74 V	41	43.97	1.87
5	29014.67	58.89 PK	74.00	-15.11	2.00 V	344	57.26	1.63
6	29014.67	46.55 AV	54.00	-7.45	2.00 V	344	44.92	1.63

Remarks:

1. Emission Level(dBuV/m) = Raw Value(dBuV) + Correction Factor(dB/m)
2. Correction Factor(dB/m) = Antenna Factor (dB/m) + Cable Factor (dB)
– Pre-Amplifier Factor (dB)
3. Margin value = Emission level – Limit value
4. The other emission levels were very low against the limit.

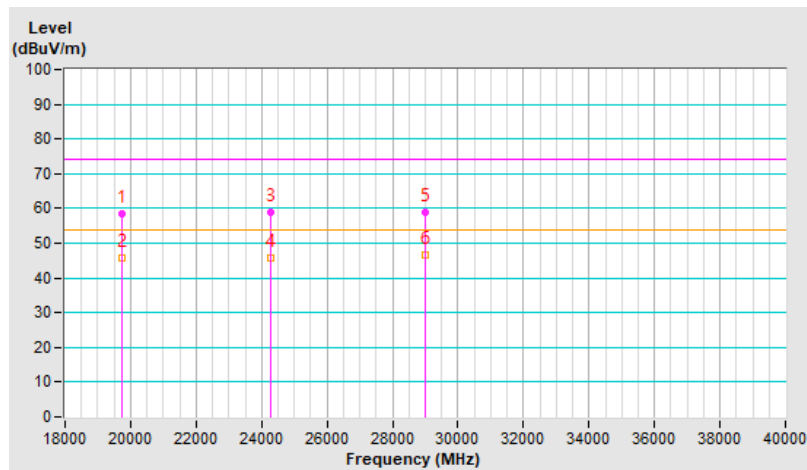

8 Pictures of Test Arrangements

Please refer to the attached file (Test Setup Photo)

9 Information of the Testing Laboratories

We, Bureau Veritas Consumer Products Services (H.K.) Ltd., Taoyuan Branch, were founded in 1988 to provide our best service in EMC, Radio, Telecom and Safety consultation. Our laboratories are FCC recognized accredited test firms and accredited according to ISO/IEC 17025.

If you have any comments, please feel free to contact us at the following:

Lin Kou EMC/RF Lab

Tel: 886-2-26052180

Fax: 886-2-26051924

Hsin Chu EMC/RF/Telecom Lab

Tel: 886-3-6668565

Fax: 886-3-6668323

Hwa Ya EMC/RF/Safety Lab

Tel: 886-3-3183232

Fax: 886-3-3270892

Email: service.adt@bureauveritas.com

Web Site: <http://ee.bureauveritas.com.tw>

The address and road map of all our labs can be found in our web site also.

--- END ---