

TEST REPORT

CERTIFICATE OF CONFORMITY

Standard: 47 CFR FCC Part 15, Subpart B, Class B

ANSI C63.4-2014

ANSI C63.4a-2017

Report No.: FDBEMI-WTW-P23090647

FCC ID.: NOIKBN365

Product: Electronic Display Device

Brand: Rakuten kobo

Model No.: N365

Received Date: 2023/5/4

Test Date: 2023/10/26

Issued Date: 2023/12/14

Applicant: NETRONIX, INC.

Address: No. 945, Boai St., Jubei City, Hsin-Chu, 30265, Taiwan

Issued By: Bureau Veritas Consumer Products Services (H.K.) Ltd., Taoyuan Branch
Hsin Chu Laboratory

Lab Address: E-2, No.1, Li Hsin 1st Road, Hsinchu Science Park, Hsinchu City 300, Taiwan

Test Location: No. 49, Ln. 206, Wende Rd., Shangshan Tsuen, Chiung Lin Hsiang, Hsin Chu Hsien 307,
Taiwan

FCC Registration /

Designation Number: 960022 / TW1058

Approved by: _____



Ken Lu / Manager

, Date: _____

2023/12/14

This test report consists of 26 pages in total. It may be duplicated completely for legal use with the approval of the applicant. It should not be reproduced except in full, without the written approval of our laboratory. The test results in the report only apply to the tested sample. The test results in this report are traceable to the national or international standards.

Prepared by : Vito Lung / Specialist



This report is governed by, and incorporates by reference, the Conditions of Testing as posted at the date of issuance of this report at <http://www.bureauveritas.com/home/about-us/our-business/cps/about-us/terms-conditions/>, and is intended for your exclusive use. Any copying or replication of this report to or for any other person or entity, or use of our name or trademark, is permitted only with our prior written permission. This report sets forth our findings solely with respect to the test samples identified herein. The results set forth in this report are not indicative or representative of the quality or characteristics of the lot from which a test sample was taken or any similar or identical product unless specifically and expressly noted. Our report includes all of the tests requested by you and the results thereof based upon the information that you provided to us. Measurement uncertainty is only provided upon request for accredited tests. Statements of conformity are based on simple acceptance criteria without taking measurement uncertainty into account, unless otherwise requested in writing. You have 60 days from date of issuance of this report to notify us of any material error or omission caused by our negligence or if you require measurement uncertainty; provided, however, that such notice shall be in writing and shall specifically address the issue you wish to raise. A failure to raise such issue within the prescribed time shall constitute your unqualified acceptance of the completeness of this report, the tests conducted and the correctness of the report contents.

Table of Contents

Release Control Record	3
1 Certificate.....	4
2 Summary of Test Results	5
2.1 Measurement Uncertainty	5
2.2 Supplementary Information	5
3 General Information	6
3.1 Description of EUT	6
3.2 Primary Clock Frequencies of Internal Source.....	7
3.3 Features of EUT	7
3.4 Operating Modes of EUT and Determination of Worst Case Operating Mode	8
3.5 Test Program Used and Operation Descriptions	9
3.6 Connection Diagram of EUT and Peripheral Devices	9
3.7 Configuration of Peripheral Devices and Cable Connections	9
4 Test Instruments	10
4.1 Conducted Emissions from Power Ports	10
4.2 Radiated Emissions up to 1 GHz	11
4.3 Radiated Emissions above 1 GHz.....	12
5 Limits of Test Items.....	13
5.1 Conducted Emissions from Power Ports	13
5.2 Radiated Emissions up to 1 GHz	13
5.3 Radiated Emissions above 1 GHz.....	13
6 Test Arrangements.....	14
6.1 Conducted Emissions from Power Ports	14
6.2 Radiated Emissions up to 1 GHz	15
6.3 Radiated Emissions above 1 GHz.....	16
7 Test Results of Test Item	17
7.1 Conducted Emissions from Power Ports	17
7.2 Radiated Emissions up to 1 GHz	19
7.3 Radiated Emissions above 1 GHz.....	21
8 Pictures of Test Arrangements	25
9 Information of the Testing Laboratories	26



Release Control Record

Issue No.	Description	Date Issued
FDBEMI-WTW-P23090647	Original release.	2023/12/14

1 Certificate

Product: Electronic Display Device

Brand: Rakuten kobo

Test Model: N365

Sample Status: Engineering sample

Applicant: NETRONIX, INC.

Test Date: 2023/10/26

Standard: 47 CFR FCC Part 15, Subpart B, Class B
ANSI C63.4–2014
ANSI C63.4a–2017

The above equipment has been tested by **Bureau Veritas Consumer Products Services (H.K.) Ltd., Taoyuan Branch**, and found compliance with the requirement of the above standards. The test record, data evaluation & Equipment Under Test (EUT) configurations represented herein are true and accurate accounts of the measurements of the sample's EMC characteristics under the conditions specified in this report.

2 Summary of Test Results

The test items that the EUT need to perform in accordance with its interfaces, evaluated functions, are as follows:

Standard / Clause	Test Item	Result	Remark
FCC Part 15.107	Conducted Emissions from Power Ports	Pass	Minimum passing Class B margin is -14.79 dB at 0.58359 MHz
FCC Part 15.109	Radiated Emissions up to 1 GHz	Pass	Minimum passing Class B margin is -4.40 dB at 689.08 MHz
FCC Part 15.109	Radiated Emissions above 1 GHz	Pass	Minimum passing Class B margin is -12.47 dB at 1799.91 MHz

Note: Determining compliance based on the results of the compliance measurement, not taking into account measurement instrumentation uncertainty.

2.1 Measurement Uncertainty

Where relevant, the following measurement uncertainty levels have been estimated for tests performed on the EUT as specified in CISPR 16-4-2:

Measurement	Specification	Expanded Uncertainty (k=2) (±)	Maximum allowable uncertainty (±)
Conducted Emissions from Power Ports	150 kHz ~ 30 MHz	1.8 dB	3.4 dB (U_{CISPR})
Radiated Emissions above 1 GHz	30 MHz ~ 1 GHz	4.43 dB	6.3 dB (U_{CISPR})
	1 GHz ~ 6 GHz	4.4 dB	5.2 dB (U_{CISPR})
	6 GHz ~ 18 GHz	5.0 dB	5.5 dB (U_{CISPR})
	18 GHz ~ 40 GHz	5.1 dB	-

The other instruments specified are routine verified to remain within the calibrated levels, no measurement uncertainty is required to be calculated.

2.2 Supplementary Information

There is not any deviation from the test standards for the test method, and no modifications required for compliance.

3 General Information

3.1 Description of EUT

Product	Electronic Display Device
Brand	Rakuten kobo
Test Model	N365
Sample Status	Engineering sample
Operating Software	NA
Power Supply Rating	3.7 Vdc from battery 5 Vdc form adapter or host equipment
Accessory Device	Refer to Note
Data Cable Supplied	USB Cable x1 (Shielded, 1.0m)

Note:

1. The EUT uses following accessories.

USB Cable			
Brand	Model	Material	Specification
LUXSHARE-ICT	LB93US005-1H	TPE	Signal Line: Shieled: Y, 1.0M, Core: N/A

3.2 Primary Clock Frequencies of Internal Source

The highest frequency generated or used within the EUT or on which the EUT operates or tunes is 5.85 GHz, provided by NETRONIX, INC., for detailed internal source, please refer to the manufacturer's specifications.

3.3 Features of EUT

The tests reported herein were performed according to the method specified by NETRONIX, INC., for detailed feature description, please refer to the manufacturer's specifications or user's manual.

3.4 Operating Modes of EUT and Determination of Worst Case Operating Mode

The EUT has been pre-tested under following test modes.

Test Condition	
Mode	Radiated Emissions up to 1 GHz
1	USB Mode(TPE) + Input Power(5 Vdc from host)
2	WiFi 2.4G+BT + Input Power(5 Vdc from host)
3	WiFi 5G+BT + Input Power(5 Vdc from host)
4	WiFi 5G+BT + Input Power(3.7 Vdc from battery)
Note: The worst case is that mode 1 is shown in bold.	

Test modes are presented in the report as below.

Test Condition	
Mode	Conducted Emissions from Power Ports
A	USB Mode(TPE) + Input Power(5 Vdc from host)
Mode	Radiated Emissions up to 1 GHz
A	USB Mode(TPE) + Input Power(5 Vdc from host)
Mode	Radiated Emissions above 1 GHz
A	USB Mode(TPE) + Input Power(5 Vdc from host)

3.5 Test Program Used and Operation Descriptions

For emission

1. Turn on the power of all equipment.
2. EUT is charging from support unit A (Laptop) via USB-A to C cable.
3. Support unit A (Laptop) reads and writes messages from EUT via USB-A to C cable.
4. Support unit A (Laptop) runs “EMC test.exe” then sends “H” messages to itself.

3.6 Connection Diagram of EUT and Peripheral Devices

For emission

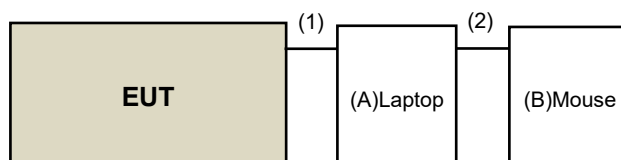

3.7 Configuration of Peripheral Devices and Cable Connections

ID	Product	Brand	Model No.	Serial No.	FCC ID	Remarks
A	Laptop	DELL	Latitude 5420	7YX61F3	FCC DOC	Provided by Lab
B	Mouse	Logitech	M-U0026	810-002182_002	N/A	Provided by Lab

ID	Cable Descriptions	Qty.	Length (m)	Shielding (Yes/No)	Cores (Qty.)	Remarks
1	USB cable	1	1	Yes	0	Provided by Applicant
2	USB-A cable	1	1.8	Yes	0	Provided by Lab

4 Test Instruments

The calibration interval of the all test instruments are 12 months and the calibrations are traceable to NML/ROC and NIST/USA.

4.1 Conducted Emissions from Power Ports

Description Manufacturer	Model No.	Serial No.	Calibrated Date	Calibrated Until
50 ohm terminal resistance	N/A	EMC-01	2023/9/25	2024/9/24
		EMC-02	2023/9/25	2024/9/24
EMI Test Receiver R&S	ESCS 30	100375	2023/5/17	2024/5/16
Fixed Attenuator STI	STI02-2200-10	007	2023/7/1	2024/6/30
LISN R&S	ENV216	100071	2023/10/25	2024/10/24
LISN Schwarzbeck	NNLK 8121	0809	2023/3/14	2024/3/13
	NSLK 8127	8127-523	2023/10/4	2024/10/3
RF Coaxial Cable JYEBAO	5D-FB	CONCAB-001	2023/7/1	2024/6/30
Software BV	BVADT_Cond_ V7.3.7.4	N/A	N/A	N/A

Notes:

1. The test was performed in HC - Conduction 2.
2. The VCCI Shielded room D Registration No. is C-20005.
3. Tested Date: 2023/10/26

4.2 Radiated Emissions up to 1 GHz

Description Manufacturer	Model No.	Serial No.	Calibrated Date	Calibrated Until
Antenna Tower & Turn Table CT	N/A	N/A	N/A	N/A
Bi_Log Antenna Schwarzbeck	VULB 9168	9168-358	2023/10/16	2024/10/15
		9168-359	2023/10/17	2024/10/16
Fixed Attenuator Mini-Circuits	UNAT-5+	CHF-001	2023/7/1	2024/6/30
Fixed attenuator Mini-Circuits	UNAT-5+	CHF-002	2023/7/1	2024/6/30
MXE EMI Receiver Agilent	N9038A	MY50010125	2023/3/24	2024/3/23
		MY50010132	2023/6/21	2024/6/20
Preamplifier Sonoma	310N	352925	2023/7/1	2024/6/30
		352926	2023/7/1	2024/6/30
RF Coaxial Cable PEWC	8D	8DCAB-001	2023/7/1	2024/6/30
	8D-FB	CHFCAB-001-1	2023/7/1	2024/6/30
		CHFCAB-001-3	2023/7/1	2024/6/30
		CHFCAB-001-4	2023/7/1	2024/6/30
		CHFCAB-002-1	2023/7/1	2024/6/30
		CHFCAB-002-3	2023/7/1	2024/6/30
		CHFCAB-002-4	2023/7/1	2024/6/30
		CHFCAB-003-1	2023/7/1	2024/6/30
		CHFCAB-003-3	2023/7/1	2024/6/30
Software BV	ADT_Radiated_V8.7.08	N/A	N/A	N/A

Notes:

1. The test was performed in HC - 10m Chamber 1. The test site validated date: 2023/6/29 (NSA)
2. The VCCI Site Registration No. is R-13252.
3. Tested Date: 2023/10/26

4.3 Radiated Emissions above 1 GHz

Description Manufacturer	Model No.	Serial No.	Calibrated Date	Calibrated Until
Antenna Tower & Turn Table CT	N/A	N/A	N/A	N/A
Fix tool for Boresight BV	BAF-01	5	N/A	N/A
Horn Antenna RFSPIN	DRH18-E	210306A18-ES	2022/11/13	2023/11/12
Horn Antenna Schwarzbeck	BBHA 9170	9170-424	2022/11/13	2023/11/12
MXA Signal Analyzer Keysight	N9020B	MY60112816	2023/5/17	2024/5/16
MXE EMI Receiver Agilent	N9038A	MY50010125	2023/3/24	2024/3/23
Preamplifier Agilent	8449B	3008A01975	2022/12/28	2023/12/27
Preamplifier EMCI	EMC118A45SE	980817	2023/8/12	2024/8/11
	EMC184045SE	980770	2023/6/1	2024/5/31
RF Coaxial Cable EMCI	EMC104-SM-SM-2500	170209	2023/2/22	2024/2/21
	EMC104-SM-SM-6000	170208	2023/2/22	2024/2/21
	EMC104-SM-SM-11000	170206	2023/2/22	2024/2/21
RF Coaxial Cable EMEC	EMC101G-KM-KM-1200	230808	2023/8/16	2024/8/15
	EMC101G-KM-KM-4500	230803	2023/8/16	2024/8/15
Software BV	ADT_Radiated_V8.7.08	N/A	N/A	N/A

Notes:

1. The test was performed in HC - 10m Chamber 1. The test site validated date: 2022/12/10 (VSWR)
2. The VCCI Site Registration No. is G-10136.
3. Tested Date: 2023/10/26

5 Limits of Test Items

5.1 Conducted Emissions from Power Ports

Frequency (MHz)	Class A (dBuV)		Class B (dBuV)	
	Quasi-peak	Average	Quasi-peak	Average
0.15 - 0.5	79	66	66 - 56	56 - 46
0.50 - 5.0	73	60	56	46
5.0 - 30.0	73	60	60	50

Notes: 1. The lower limit shall apply at the transition frequencies.
 2. The limit decreases linearly with the logarithm of the frequency in the range of 0.15 to 0.50 MHz.

5.2 Radiated Emissions up to 1 GHz

Emissions radiated outside of the specified bands, shall be according to the general radiated limits as following:

Radiated Emissions Limits at 10 meters (dB μ V/m)				
Frequencies (MHz)	FCC 15B, Class A	FCC 15B, Class B	CISPR 22, Class A	CISPR 22, Class B
30-88	39.1	29.5	40	30
88-216	43.5	33.1		
216-230	46.4	35.6		
230-960				
960-1000	49.5	43.5	47	37

Radiated Emissions Limits at 3 meters (dB μ V/m)				
Frequencies (MHz)	FCC 15B, Class A	FCC 15B, Class B	CISPR 22, Class A	CISPR 22, Class B
30-88	49.5	40.0	50.5	40.5
88-216	54.0	43.5		
216-230	56.9	46.0		
230-960				
960-1000	60.0	54.0	57.5	47.5

Notes: 1. The lower limit shall apply at the transition frequencies.

5.3 Radiated Emissions above 1 GHz

Frequency Range (For unintentional radiators)

Highest frequency generated or used in the device or on which the device operates or tunes (MHz)	Upper frequency of measurement range (MHz)
Below 1.705	30
1.705-108	1000
108-500	2000
500-1000	5000
Above 1000	5th harmonic of the highest frequency or 40GHz, whichever is lower

Radiated Emissions Limits at 3 meters (dB μ V/m)		
Frequency range	Class A	Class B
Above 1GHz	Avg: 60 Peak: 80	Avg: 54 Peak: 74

Notes: 1. These limit levels apply for a measurement distance of 3 m. If using a different measurement distance, the measured levels shall be extrapolated to the 3 m limit distance using a factor of 20 dB per decade of distance. The measurement distance shall place the measurement antenna in the far field of the ITE or digital apparatus under test.

6 Test Arrangements

6.1 Conducted Emissions from Power Ports

- For the table-top EUT is placed on a 0.8 meter insulation table; for the floor standing EUT shall be insulated (by insulation of 12 mm) from the horizontal reference ground plane. The EUT is placed 0.4 meters from the conducting wall of the shielded room with EUT being connected to the power mains through a line impedance stabilization network (LISN). Other support units are connected to the power mains through another LISN. They provide coupling impedance for the measuring instrument.
- Both lines of the power mains connected to the EUT were checked for maximum conducted interference.
- The test results of conducted emissions at mains ports are recorded of six worst margins for quasi-peak (mandatory) [and average (if necessary)] values against the limits at frequencies of interest unless the margin is 20 dB or greater.

Note: The resolution bandwidth and video bandwidth of test receiver is 9kHz for quasi-peak detection (QP) and average detection (AV) at frequency 0.15MHz-30MHz.

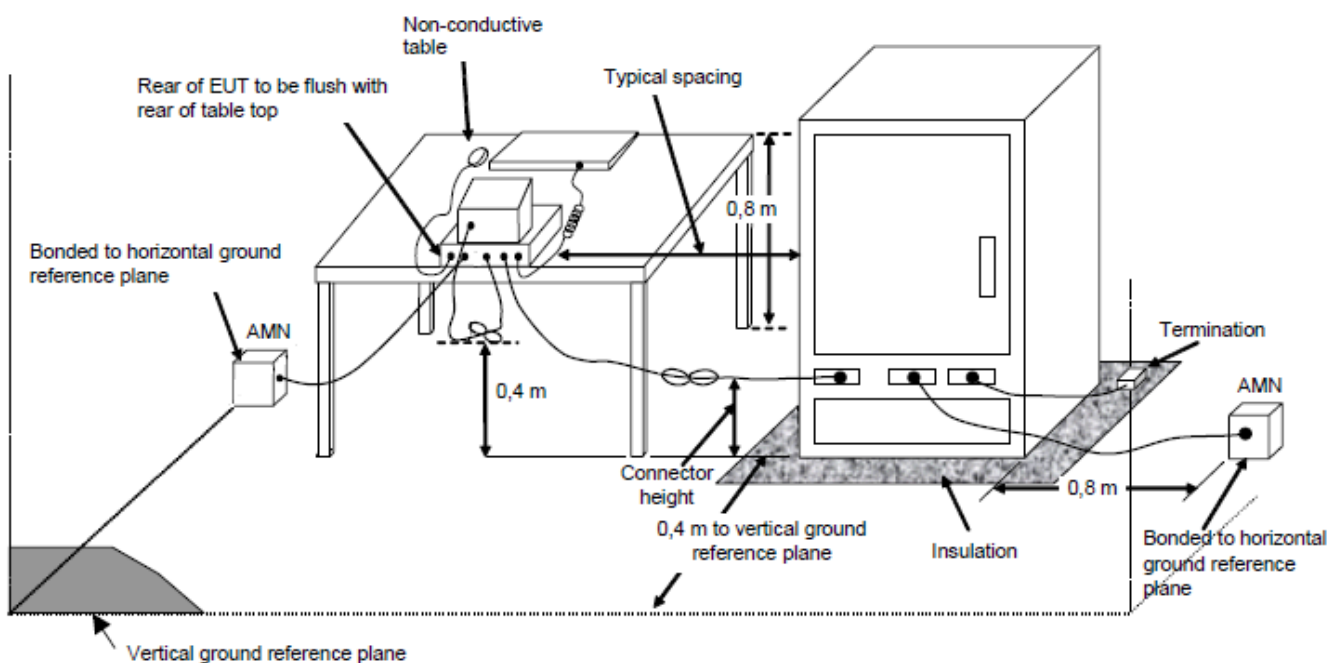

For the actual test configuration, please refer to the related Item – Photographs of the Test Configuration.

6.2 Radiated Emissions up to 1 GHz

- a. For the table-top EUT is placed on a 0.8 meter to the top of rotating table; for the floor standing EUT shall be insulated (by insulation of 12 mm) from the horizontal reference ground plane. The rotating table is rotated 360 degrees to determine the position of the highest radiation. If the equipment requires a dedicated ground connection, this shall be provided and bonded to the RGP.
- b. The EUT was set 10 meters away from the interference-receiving antenna, which was mounted on the top of a variable-height antenna tower.
- c. The antenna is a broadband antenna, and its height is varied from one meter to four meters above the ground to determine the maximum value of the field strength. Both horizontal and vertical polarizations of the antenna are set to make the measurement.
- d. For each suspected emission, the EUT was arranged to its worst case and then the antenna was tuned to heights from 1 meter to 4 meters and the rotatable table was turned from 0 degrees to 360 degrees to find the maximum reading.
- e. The test-receiver system was set to quasi-peak detect function and specified bandwidth with maximum hold mode when the test frequency is up to 1 GHz.

Note: The resolution bandwidth and video bandwidth of test receiver/spectrum analyzer is 120kHz for quasi-peak detection (QP) at frequency up to 1GHz.

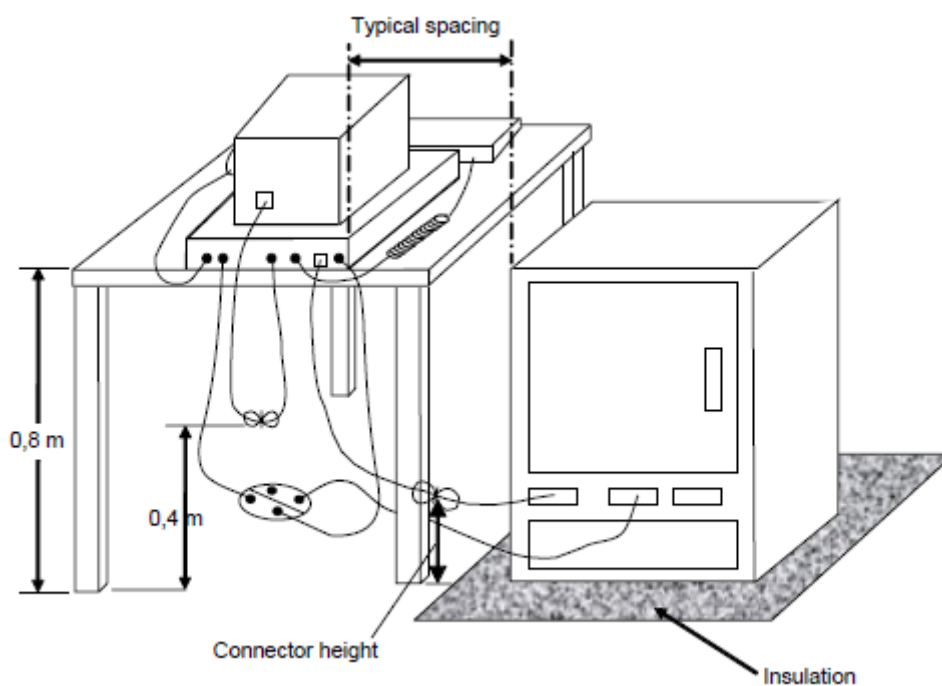

For the actual test configuration, please refer to the related Item – Photographs of the Test Configuration.

6.3 Radiated Emissions above 1 GHz

- For the table-top EUT is placed on a 0.8 meter to the top of rotating table; for the floor standing EUT shall be insulated (by insulation of 12 mm) from the horizontal reference ground plane. The rotating table is rotated 360 degrees to determine the position of the highest radiation. If the equipment requires a dedicated ground connection, this shall be provided and bonded to the RGP.
- The EUT was set $d = 3$ meters away from the interference-receiving antenna, which was mounted on the top of a variable-height antenna tower.
- The height of antenna can be varied from one meter to four meters, the height of adjustment depends on the EUT height and the antenna 3dB beamwidth both, to detect the maximum value of the field strength. Both horizontal and vertical polarizations of the antenna are set to make the measurement.
- For each suspected emission, the EUT was arranged to its worst case and then the antenna was tuned to heights and the rotatable table was turned from 0 degrees to 360 degrees to find the maximum reading.
- The spectrum analyzer system was set to peak and average detects function and specified bandwidth with maximum hold mode when the test frequency is above 1 GHz.

Note: The resolution bandwidth of test receiver/spectrum analyzer is 1MHz and video bandwidth is 3MHz for Peak detection (PK) at frequency above 1GHz. The resolution bandwidth of test receiver/spectrum analyzer is 1 MHz for Average detection (AV) at frequency above 1GHz.

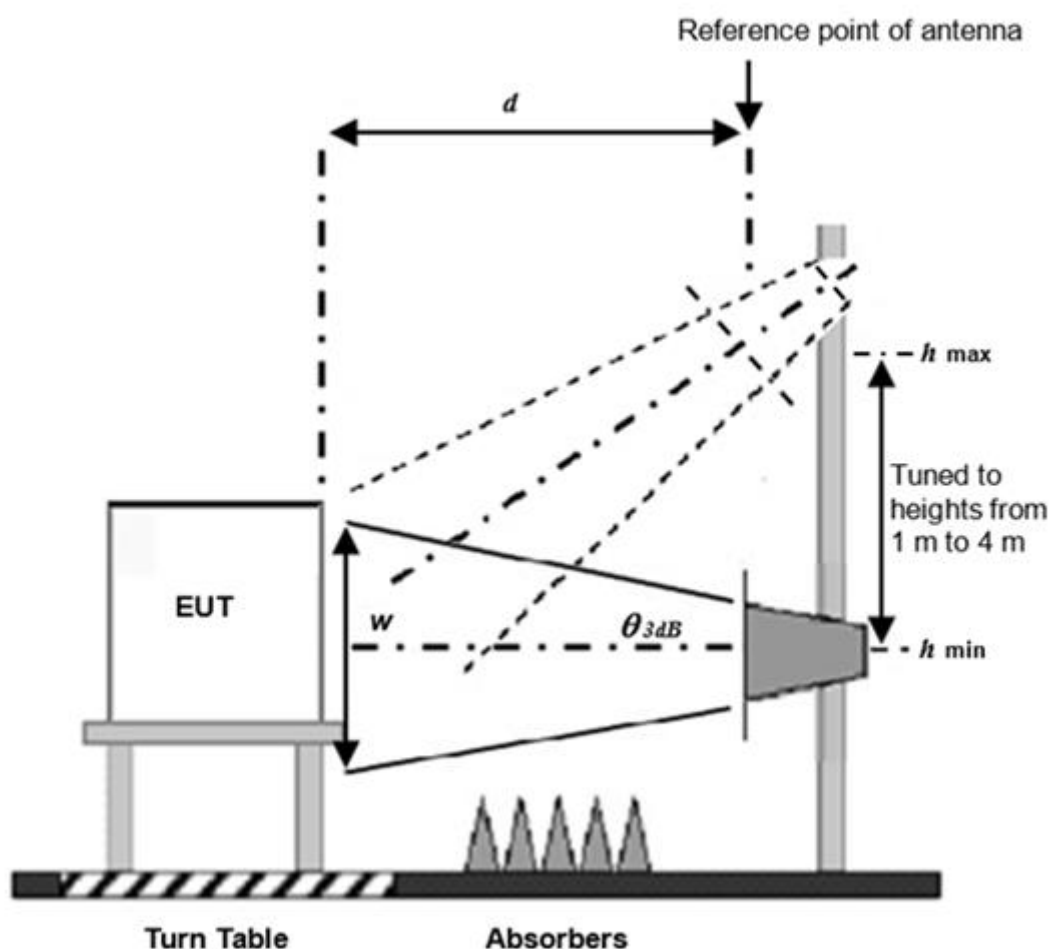

For the actual test configuration, please refer to the related item – Photographs of the Test Configuration.

7 Test Results of Test Item

7.1 Conducted Emissions from Power Ports

Mode A

Frequency Range	150 kHz ~ 30 MHz	Detector Function & Resolution Bandwidth	Quasi-Peak (QP) / Average (AV), 9kHz
Input Power	5 Vdc from host	Environmental Conditions	25°C, 75% RH
Tested by	Nick Lo		

Phase Of Power : Line (L)										
No	Frequency (MHz)	Correction Factor (dB)	Reading Value (dBuV)		Emission Level (dBuV)		Limit (dBuV)		Margin (dB)	
			Q.P.	AV.	Q.P.	AV.	Q.P.	AV.	Q.P.	AV.
1	0.15000	10.16	38.81	24.02	48.97	34.18	66.00	56.00	-17.03	-21.82
2	0.15781	10.17	37.79	25.25	47.96	35.42	65.58	55.58	-17.62	-20.16
3	0.19297	10.17	30.88	17.03	41.05	27.20	63.91	53.91	-22.86	-26.71
4	0.58359	10.18	26.36	21.03	36.54	31.21	56.00	46.00	-19.46	-14.79
5	4.23438	10.23	19.78	9.01	30.01	19.24	56.00	46.00	-25.99	-26.76
6	13.00391	10.58	22.37	17.04	32.95	27.62	60.00	50.00	-27.05	-22.38

Remarks:

1. Q.P. and AV. are abbreviations of quasi-peak and average individually.
2. The emission levels of other frequencies were very low against the limit.
3. Margin value = Emission level – Limit value
4. Correction factor = Insertion loss + Cable loss
5. Emission Level = Correction Factor + Reading Value

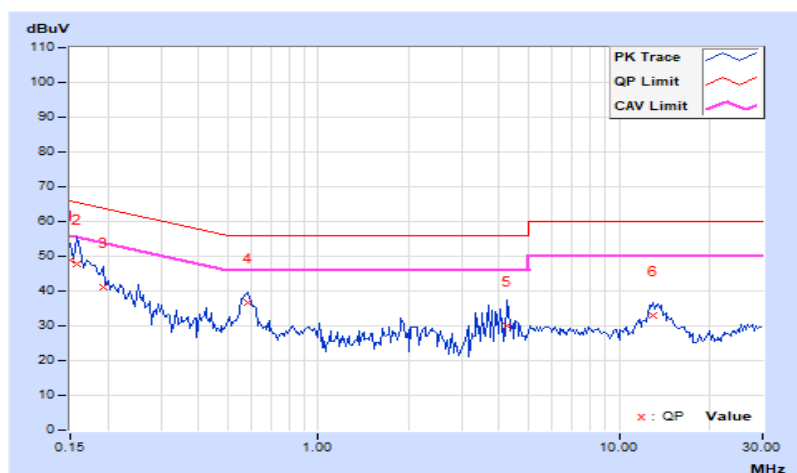

Frequency Range	150 kHz ~ 30 MHz	Detector Function & Resolution Bandwidth	Quasi-Peak (QP) / Average (AV), 9kHz
Input Power	5 Vdc from host	Environmental Conditions	25°C, 75% RH
Tested by	Nick Lo		

Phase Of Power : Neutral (N)										
No	Frequency (MHz)	Correction Factor (dB)	Reading Value (dBuV)		Emission Level (dBuV)		Limit (dBuV)		Margin (dB)	
			Q.P.	AV.	Q.P.	AV.	Q.P.	AV.	Q.P.	AV.
1	0.15000	10.18	40.12	25.63	50.30	35.81	66.00	56.00	-15.70	-20.19
2	0.16562	10.18	37.90	23.27	48.08	33.45	65.18	55.18	-17.10	-21.73
3	0.25547	10.18	25.25	15.20	35.43	25.38	61.58	51.58	-26.15	-26.20
4	0.57969	10.18	25.67	20.60	35.85	30.78	56.00	46.00	-20.15	-15.22
5	3.67578	10.25	19.81	9.55	30.06	19.80	56.00	46.00	-25.94	-26.20
6	13.39453	10.58	20.20	14.75	30.78	25.33	60.00	50.00	-29.22	-24.67

Remarks:

1. Q.P. and AV. are abbreviations of quasi-peak and average individually.
2. The emission levels of other frequencies were very low against the limit.
3. Margin value = Emission level – Limit value
4. Correction factor = Insertion loss + Cable loss
5. Emission Level = Correction Factor + Reading Value

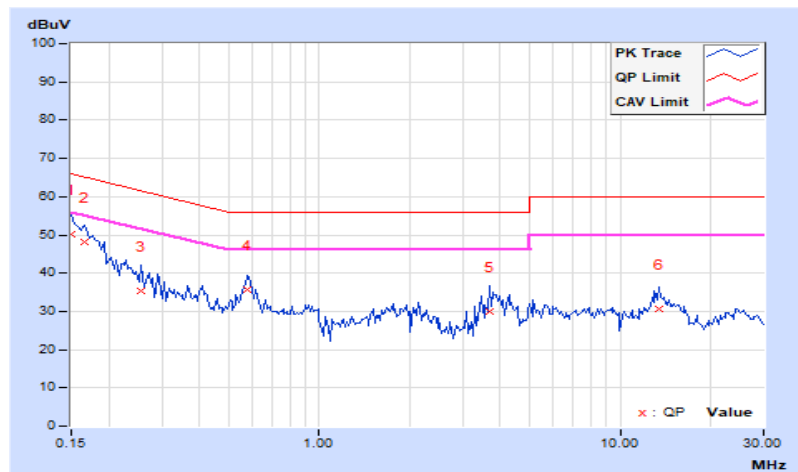

7.2 Radiated Emissions up to 1 GHz

Mode A

Frequency Range	30 MHz ~ 1 GHz	Detector Function & Resolution Bandwidth	Quasi-Peak (QP), 120 kHz
Input Power	5 Vdc from host	Environmental Conditions	28°C, 70% RH
Tested By	Paul Chen		

Antenna Polarity & Test Distance : Horizontal at 10 m								
No	Frequency (MHz)	Emission Level (dBuV/m)	Limit (dBuV/m)	Margin (dB)	Antenna Height (m)	Table Angle (Degree)	Raw Value (dBuV)	Correction Factor (dB/m)
1	226.33	22.87 QP	30.00	-7.13	4.00 H	177	37.16	-14.29
2	273.83	28.92 QP	37.00	-8.08	3.66 H	107	40.28	-11.36
3	580.28	26.49 QP	37.00	-10.51	1.87 H	317	30.05	-3.56
4	689.08	32.60 QP	37.00	-4.40	1.49 H	285	34.20	-1.60
5	719.93	31.73 QP	37.00	-5.27	1.00 H	111	32.66	-0.93
6	991.46	31.05 QP	37.00	-5.95	1.00 H	99	27.00	4.05

Remarks:

1. Emission Level(dBuV/m) = Raw Value(dBuV) + Correction Factor(dB/m)
2. Correction Factor(dB/m) = Antenna Factor (dB/m) + Cable Factor (dB) – Pre-Amplifier Factor (dB)
3. Margin value = Emission level – Limit value
4. The other emission levels were very low against the limit.

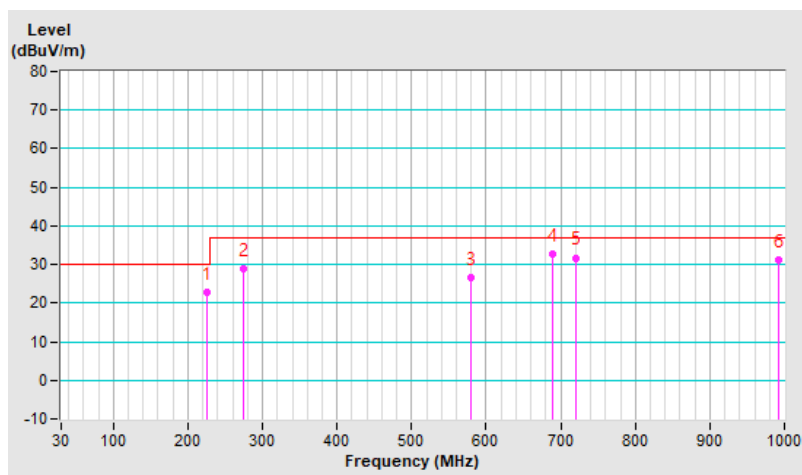

Frequency Range	30 MHz ~ 1 GHz	Detector Function & Resolution Bandwidth	Quasi-Peak (QP), 120 kHz
Input Power	5 Vdc from host	Environmental Conditions	28°C, 70% RH
Tested By	Paul Chen		

Antenna Polarity & Test Distance : Vertical at 10 m								
No	Frequency (MHz)	Emission Level (dBuV/m)	Limit (dBuV/m)	Margin (dB)	Antenna Height (m)	Table Angle (Degree)	Raw Value (dBuV)	Correction Factor (dB/m)
1	59.07	21.17 QP	30.00	-8.83	3.21 V	241	34.51	-13.34
2	109.51	25.09 QP	30.00	-4.91	1.00 V	343	40.53	-15.44
3	272.66	29.40 QP	37.00	-7.60	1.00 V	337	40.90	-11.50
4	594.02	29.68 QP	37.00	-7.32	3.52 V	320	32.69	-3.01
5	720.03	30.43 QP	37.00	-6.57	2.73 V	325	31.33	-0.90
6	980.34	31.23 QP	37.00	-5.77	1.80 V	138	26.66	4.57

Remarks:

1. Emission Level(dBuV/m) = Raw Value(dBuV) + Correction Factor(dB/m)
2. Correction Factor(dB/m) = Antenna Factor (dB/m) + Cable Factor (dB) – Pre-Amplifier Factor (dB)
3. Margin value = Emission level – Limit value
4. The other emission levels were very low against the limit.

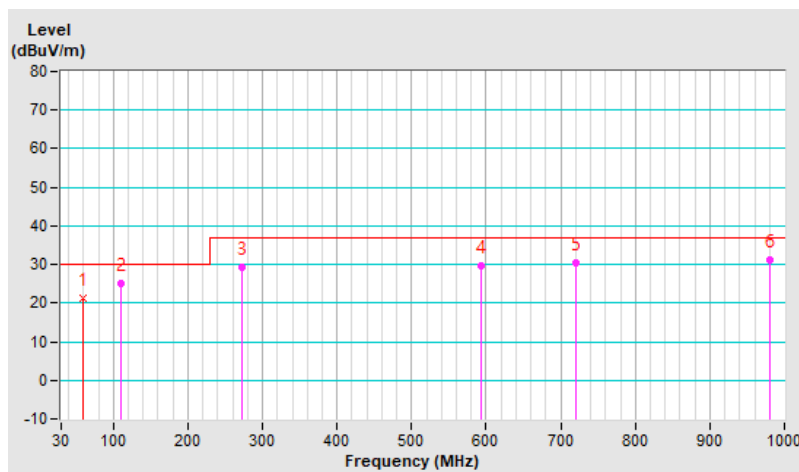

7.3 Radiated Emissions above 1 GHz

Mode A

Frequency Range	1 GHz ~ 18 GHz	Detector Function & Resolution Bandwidth	Peak (PK) / Average (AV), 1MHz
Input Power	5 Vdc from host	Environmental Conditions	28°C, 70% RH
Tested By	Paul Chen		

Antenna Polarity & Test Distance : Horizontal at 3 m

No	Frequency (MHz)	Emission Level (dBuV/m)	Limit (dBuV/m)	Margin (dB)	Antenna Height (m)	Table Angle (Degree)	Raw Value (dBuV)	Correction Factor (dB/m)
1	1799.91	45.83 PK	74.00	-28.17	1.28 H	269	53.63	-7.80
2	1799.91	41.53 AV	54.00	-12.47	1.28 H	269	49.33	-7.80
3	2426.32	46.15 PK	74.00	-27.85	1.51 H	241	51.15	-5.00
4	2426.32	25.69 AV	54.00	-28.31	1.51 H	241	30.69	-5.00
5	6674.88	44.19 PK	74.00	-29.81	1.32 H	307	40.92	3.27
6	6674.88	31.81 AV	54.00	-22.19	1.32 H	307	28.54	3.27
7	9758.17	46.62 PK	74.00	-27.38	2.22 H	360	43.14	3.48
8	9758.17	33.87 AV	54.00	-20.13	2.22 H	360	30.39	3.48
9	14015.76	50.44 PK	74.00	-23.56	1.00 H	255	46.03	4.41
10	14015.76	37.76 AV	54.00	-16.24	1.00 H	255	33.35	4.41
11	17263.18	51.32 PK	74.00	-22.68	1.93 H	252	47.75	3.57
12	17263.18	38.72 AV	54.00	-15.28	1.93 H	252	35.15	3.57

Remarks:

- Emission Level(dBuV/m) = Raw Value(dBuV) + Correction Factor(dB/m)
- Correction Factor(dB/m) = Antenna Factor (dB/m) + Cable Factor (dB)
– Pre-Amplifier Factor (dB)
- Margin value = Emission level – Limit value
- The other emission levels were very low against the limit.

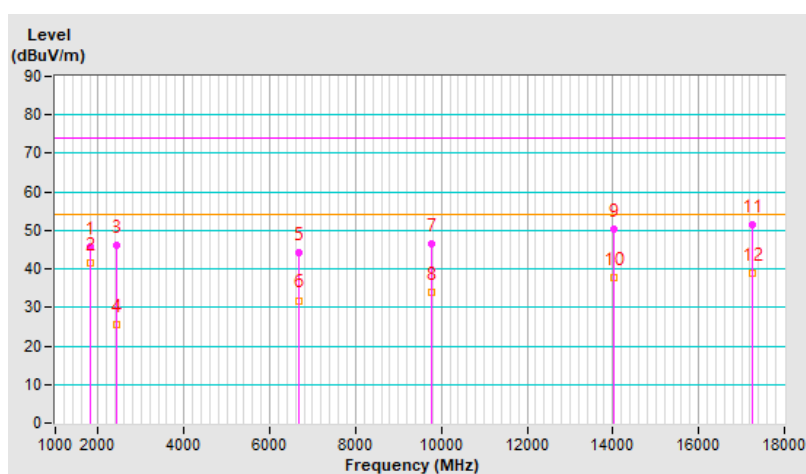

Frequency Range	1 GHz ~ 18 GHz	Detector Function & Resolution Bandwidth	Peak (PK) / Average (AV), 1MHz
Input Power	5 Vdc from host	Environmental Conditions	28°C, 70% RH
Tested By	Paul Chen		

Antenna Polarity & Test Distance : Vertical at 3 m								
No	Frequency (MHz)	Emission Level (dBuV/m)	Limit (dBuV/m)	Margin (dB)	Antenna Height (m)	Table Angle (Degree)	Raw Value (dBuV)	Correction Factor (dB/m)
1	2480.70	41.58 PK	74.00	-32.42	1.77 V	360	46.63	-5.05
2	2480.70	22.39 AV	54.00	-31.61	1.77 V	360	27.44	-5.05
3	3400.12	41.27 PK	74.00	-32.73	1.34 V	157	45.13	-3.86
4	3400.12	32.18 AV	54.00	-21.82	1.34 V	157	36.04	-3.86
5	5314.27	54.88 PK	74.00	-19.12	1.11 V	189	55.78	-0.90
6	5314.27	29.39 AV	54.00	-24.61	1.11 V	189	30.29	-0.90
7	9626.97	46.18 PK	74.00	-27.82	1.82 V	55	42.81	3.37
8	9626.97	33.64 AV	54.00	-20.36	1.82 V	55	30.27	3.37
9	12835.30	49.68 PK	74.00	-24.32	2.07 V	69	44.87	4.81
10	12835.30	36.78 AV	54.00	-17.22	2.07 V	69	31.97	4.81
11	15803.53	52.38 PK	74.00	-21.62	1.00 V	196	46.79	5.59
12	15803.53	39.41 AV	54.00	-14.59	1.00 V	196	33.82	5.59

Remarks:

1. Emission Level(dBuV/m) = Raw Value(dBuV) + Correction Factor(dB/m)
2. Correction Factor(dB/m) = Antenna Factor (dB/m) + Cable Factor (dB) – Pre-Amplifier Factor (dB)
3. Margin value = Emission level – Limit value
4. The other emission levels were very low against the limit.

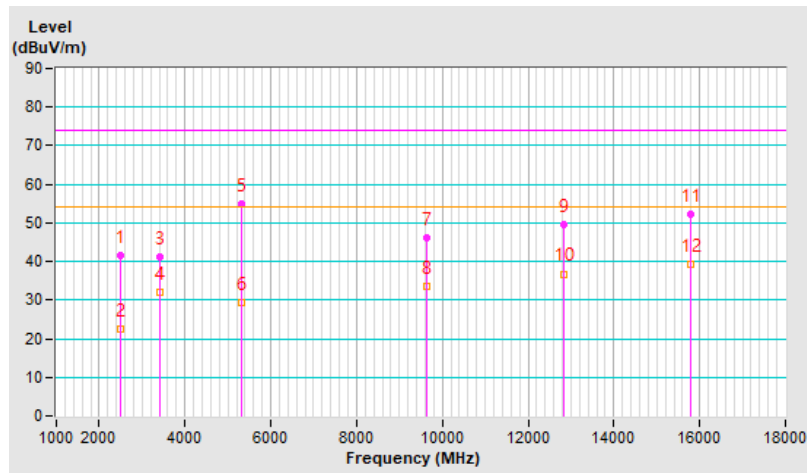

Frequency Range	1 GHz ~ 40 GHz	Detector Function & Resolution Bandwidth	Peak (PK) / Average (AV), 1MHz
Input Power	5 Vdc from host	Environmental Conditions	28°C, 70% RH
Tested By	Paul Chen		

Antenna Polarity & Test Distance : Horizontal at 3 m								
No	Frequency (MHz)	Emission Level (dBuV/m)	Limit (dBuV/m)	Margin (dB)	Antenna Height (m)	Table Angle (Degree)	Raw Value (dBuV)	Correction Factor (dB/m)
1	18774.40	45.22 PK	74.00	-28.78	1.34 H	141	53.95	-8.73
2	18774.40	32.59 AV	54.00	-21.41	1.34 H	141	41.32	-8.73
3	22595.74	44.75 PK	74.00	-29.25	1.52 H	30	49.72	-4.97
4	22595.74	32.45 AV	54.00	-21.55	1.52 H	30	37.42	-4.97
5	26665.54	46.99 PK	74.00	-27.01	1.67 H	360	49.30	-2.31
6	26665.54	34.09 AV	54.00	-19.91	1.67 H	360	36.40	-2.31

Remarks:

1. Emission Level(dBuV/m) = Raw Value(dBuV) + Correction Factor(dB/m)
2. Correction Factor(dB/m) = Antenna Factor (dB/m) + Cable Factor (dB) – Pre-Amplifier Factor (dB)
3. Margin value = Emission level – Limit value
4. The other emission levels were very low against the limit.

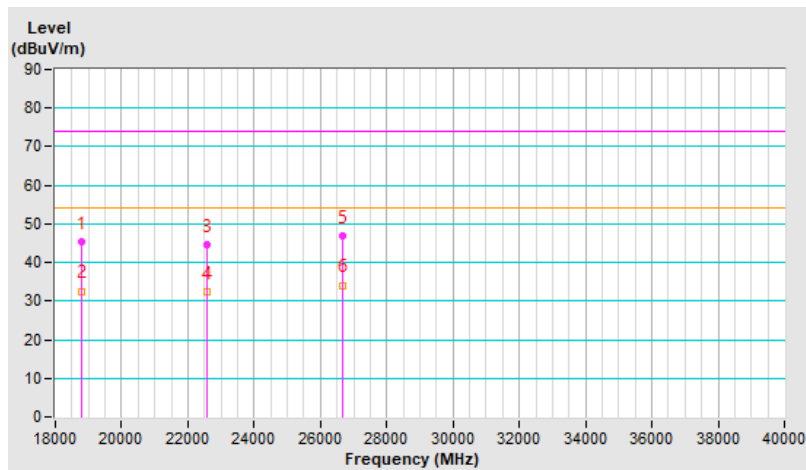

Frequency Range	1 GHz ~ 40 GHz	Detector Function & Resolution Bandwidth	Peak (PK) / Average (AV), 1MHz
Input Power	5 Vdc from host	Environmental Conditions	28°C, 70% RH
Tested By	Paul Chen		

Antenna Polarity & Test Distance : Vertical at 3 m								
No	Frequency (MHz)	Emission Level (dBuV/m)	Limit (dBuV/m)	Margin (dB)	Antenna Height (m)	Table Angle (Degree)	Raw Value (dBuV)	Correction Factor (dB/m)
1	20429.82	45.26 PK	74.00	-28.74	2.10 V	133	51.74	-6.48
2	20429.82	32.58 AV	54.00	-21.42	2.10 V	133	39.06	-6.48
3	25212.28	46.18 PK	74.00	-27.82	1.33 V	141	49.23	-3.05
4	25212.28	33.56 AV	54.00	-20.44	1.33 V	141	36.61	-3.05
5	27475.04	47.02 PK	74.00	-26.98	1.52 V	61	49.80	-2.78
6	27475.04	34.53 AV	54.00	-19.47	1.52 V	61	37.31	-2.78

Remarks:

1. Emission Level(dBuV/m) = Raw Value(dBuV) + Correction Factor(dB/m)
2. Correction Factor(dB/m) = Antenna Factor (dB/m) + Cable Factor (dB)
– Pre-Amplifier Factor (dB)
3. Margin value = Emission level – Limit value
4. The other emission levels were very low against the limit.

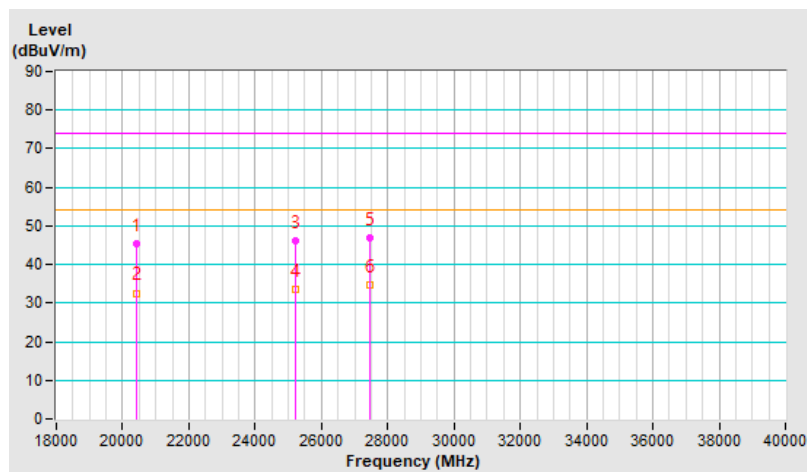

8 Pictures of Test Arrangements

Please refer to the attached file (Test Setup Photo)

9 Information of the Testing Laboratories

We, Bureau Veritas Consumer Products Services (H.K.) Ltd., Taoyuan Branch, were founded in 1988 to provide our best service in EMC, Radio, Telecom and Safety consultation. Our laboratories are FCC recognized accredited test firms and accredited according to ISO/IEC 17025.

If you have any comments, please feel free to contact us at the following:

Lin Kou EMC/RF Lab

Tel: 886-2-26052180

Fax: 886-2-26051924

Hsin Chu EMC/RF/Telecom Lab

Tel: 886-3-6668565

Fax: 886-3-6668323

Hwa Ya EMC/RF/Safety Lab

Tel: 886-3-3183232

Fax: 886-3-3270892

Email: service.adt@bureauveritas.com

Web Site: <http://ee.bureauveritas.com.tw>

The address and road map of all our labs can be found in our web site also.

--- END ---