

FCC DoC Test Report

Report No.: FD160413E14

Test Model: N236

Received Date: Apr. 13 , 2016

Test Date: Apr. 23 to June 07, 2016

Issued Date: June 08, 2016

Applicant: NETRONIX, INC

Address: No.945,Boai St.,Jubei City,Hsin-Chu,302,Taiwan,R.O.C.

Issued By: Bureau Veritas Consumer Products Services (H.K.) Ltd., Taoyuan Branch
Hsin Chu Laboratory

Lab Address: E-2, No.1, Li Hsin 1st Road, Hsinchu Science Park, Hsinchu City 300,
Taiwan R.O.C.

Test Location (1): E-2, No.1, Li Hsin 1st Road, Hsinchu Science Park, Hsinchu City 300,
Taiwan R.O.C.

Test Location (2): No. 49, Ln. 206, Wende Rd., Shangshan Tsuen, Chiung Lin Hsiang, Hsin
Chu Hsien 307, Taiwan R.O.C.

Test Location (3): No. 81-1, Lu Liao Keng, 9th Ling,Wu Lung Tsuen, Chiung Lin Hsiang, Hsin
Chu Hsien 307, Taiwan R.O.C.



This report is for your exclusive use. Any copying or replication of this report to or for any other person or entity, or use of our name or trademark, is permitted only with our prior written permission. This report sets forth our findings solely with respect to the test samples identified herein. The results set forth in this report are not indicative or representative of the quality or characteristics of the lot from which a test sample was taken or any similar or identical product unless specifically and expressly noted. Our report includes all of the tests requested by you and the results thereof based upon the information that you provided to us. You have 60 days from date of issuance of this report to notify us of any material error or omission caused by our negligence, provided, however, that such notice shall be in writing and shall specifically address the issue you wish to raise. A failure to raise such issue within the prescribed time shall constitute your unqualified acceptance of the completeness of this report, the tests conducted and the correctness of the report contents. Unless specific mention, the uncertainty of measurement has been explicitly taken into account to declare the compliance or non-compliance to the specification. The report must not be used by the client to claim product certification, approval, or endorsement by TAF or any government agencies.



Table of Contents

Release Control Record	3
1 Certificate of Conformity	4
2 Summary of Test Results	5
2.1 Measurement Uncertainty	5
2.2 Modification Record	5
3 General Information	6
3.1 General Description of EUT	6
3.2 Operating Modes of EUT and Determination of Worst Case Operating Mode	7
3.3 Test Program Used and Operation Descriptions	8
3.4 Primary Clock Frequencies of Internal Source	8
3.5 Miscellaneous	9
4 Configuration and Connections with EUT	10
4.1 Configuration of Peripheral Devices and Cable Connections	12
5 Conducted Emissions at Mains Ports	13
5.1 Limits	13
5.2 Test Instruments	13
5.3 Test Arrangement	15
5.4 Supplementary Information	15
5.6 Test Results (Mode1)	16
5.7 Test Results (Mode2)	18
6 Radiated Emissions up to 1 GHz	20
6.1 Limits	20
6.2 Test Instruments	21
6.3 Test Arrangement	22
6.4 Supplementary Information	22
6.5 Test Results	23
7 Radiated Emissions above 1 GHz	25
7.1 Limits	25
7.2 Test Instruments	26
7.3 Test Arrangement	27
7.4 Supplementary Information	27
7.5 Test Results	28
Appendix – Information on the Testing Laboratories	30



A D T

Release Control Record

Issue No.	Description	Date Issued
FD160413E14	Original release.	June 08, 2016



1 Certificate of Conformity

Product: 6 inch Electronic Display Device

Brand: Kobo

Test Model: N236

Sample Status: ENGINEERING SAMPLE

Applicant: NETRONIX, INC

Test Date: Apr. 23 to June 07, 2016

Standards: 47 CFR FCC Part 15, Subpart B, Class B
ICES-003:2016 Issue 6, Class B
ANSI C63.4:2014

The above equipment has been tested by **Bureau Veritas Consumer Products Services (H.K.) Ltd., Taoyuan Branch**, and found compliance with the requirement of the above standards. The test record, data evaluation & Equipment Under Test (EUT) configurations represented herein are true and accurate accounts of the measurements of the sample's EMC characteristics under the conditions specified in this report.

Prepared by : Wendy Wu , **Date:** June 08, 2016
Wendy Wu / Specialist

Approved by : Ken Lu , **Date:** June 08, 2016
Ken Lu / Manager

2 Summary of Test Results

47 CFR FCC Part 15, Subpart B / ICES-003:2016 Issue 6, Class B

ANSI C63.4:2014

FCC Clause	ICES-003 Clause	Test Item	Result/Remarks	Verdict
15.107	6.1	AC Power Line Conducted Emissions	Minimum passing Class B margin is -4.06 dB at 0.61484 MHz Without AC power port of the EUT	Pass
15.109	6.2.1	Radiated Emissions up to 1 GHz	Minimum passing Class B margin is -3.33 dB at 749.90 MHz	Pass
	6.2.2	Radiated Emissions above 1 GHz	Minimum passing Class B margin is -20.11 dB at 4639.24 MHz EUT's highest frequency is below 108 MHz	Pass

Note: There is no deviation to the applied test methods and requirements covered by the scope of this report.

2.1 Measurement Uncertainty

Where relevant, the following measurement uncertainty levels have been estimated for tests performed on the EUT:

The listed uncertainties are the worst case uncertainty for the entire range of measurement. Please note that the uncertainty values are provided for informational purposes only and are not used in determining the PASS/FAIL results.

Measurement	Frequency	Expended Uncertainty (k=2) (±)
Conducted Emissions at mains ports	150kHz ~ 30MHz	1.83 dB
Radiated Emissions up to 1 GHz	30MHz ~ 1GHz	3.99 dB
Radiated Emissions above 1 GHz	Above 1GHz	3.65 dB

2.2 Modification Record

There were no modifications required for compliance.

3 General Information

3.1 General Description of EUT

Product	6 inch Electronic Display Device
Brand	Kobo
Test Model	N236
Sample Status	ENGINEERING SAMPLE
Operating Software	NA
Power Supply rating	3.7Vdc from battery or 5Vdc from host equipment
Operating Frequency	NA
Accessory Device	NA
Data Cable Supplied	USB cable (Shielded, 1m) x 1

Note:

- The EUT must be supplied with a rechargeable battery as following table:

Brand	Model No.	Spec.
SPRINGPOWER TECHNOLOGY	SP 285083	DC: 3.7V, 1500mAh

- The antenna provided to the EUT, please refer to the following table:

Brand	Model	Ant. Gain (dBi)	Frequency range (GHz to GHz)	Antenna Type	Antenna Connector	Cable Length (mm)
Walsin Technology Corporation	RFECA3216060AAT	2	2.4~2.4835 GHz	Ceramic antenna	soldering terminal	NA

- The EUT incorporates a SISO function.

MODULATION MODE	DATA RATE (MCS)	TX & RX CONFIGURATION	
802.11b	1 ~ 11Mbps	1TX	1RX
802.11g	6 ~ 54Mbps	1TX	1RX
802.11n (HT20)	MCS 0~7	1TX	1RX

- When USB port is charging the rechargeable battery, the EUT has WiFi function under charging mode. And the USB port is connected to Host unit, the EUT WiFi function will be disabled.
- The above EUT information is declared by manufacturer and for more detailed features description, please refer to the manufacturer's specifications or user's manual.

3.2 Operating Modes of EUT and Determination of Worst Case Operating Mode

EUT has been pre-tested under following test modes, and test mode D was the worst case for final test.

Test Condition (Radiated emission)		
Test Mode	Polarity	Description
Mode A	X Plane	Wireless Link
Mode B	Y Plane	Wireless Link
Mode C	Z Plane	Wireless Link
Mode D	X Plane	USB mode

Test modes are presented in the report as below.

Conducted emission test		
Test Mode	Polarity	Description
Mode 1	X Plane	USB mode (power from host)
Mode 2	X Plane	USB mode (power from adapter)

Radiated emission test		
Test Mode	Polarity	Description
Mode 1	X Plane	USB mode

3.3 Test Program Used and Operation Descriptions

For Conducted/Radiated test Mode 1:

1. Turn on the power of all equipment.
2. Support unit B (Notebook Computer) runs "EMCTest.bat" program to enable all functions of EUT.
3. Support unit B (Notebook Computer) runs "EMCTEST.EXE" scrolls "H" patterns on its screen.

For Conducted test Mode 2 :

1. The EUT (Battery) was recharged from adapter via one USB cable continuously.

3.4 Primary Clock Frequencies of Internal Source

The EUT is a 2.4GHz WLAN device by NETRONIX, INC., for detailed internal source, please refer to the manufacturer's specifications.

3.5 Miscellaneous

Labelling Requirements for Part 15 Devices:

➤ Verification

The specific labelling requirements for a device subject to the Verification procedure are contained in Section 15.19(a). These labelling requirements are:

If the device is subject only to Verification, include a label bearing a unique identifier (Section 2.954) and one of three compliance statements specified in Section 15.19(a). If the labeling area for the device is so small, and/or it is not practical to place the compliance statement on the device, then the statement can be placed in the user manual or product packaging (Section 15.19(a)(5)). However, the device must still be labelled with the unique identifier (Verification). Generally, devices smaller than the palm of the hand are considered too small for the compliance statement.

➤ Certification

If the device is subject to Certification: (1) Section 2.925 contains information on identification of the equipment; (2) include a label bearing an FCC Identifier (FCC ID) (Section 2.926) and (3) include the appropriate compliance statement in Section 15.19(a). If the device is considered too small and therefore it is impractical (smaller than the palm of the hand) to display the compliance statement, then the statement may be placed in the user manual or product packaging. However, the device must still be labelled with the FCC ID. If the device is unquestionably too small for the FCC ID to be readable (smaller than 4-6 points), the FCC ID may be placed in the user manual. However, it must be determined that the device itself is too small – the label area allocated to the FCC ID may not be reduced because of over crowded identification of other product and regulatory information.

An electronic display of the FCC ID (see 9. Electronic Labelling below) may be used for Certification of Section 15.212 modular transmitters and software defined radios (Section 2.944).

➤ Declaration of Conformity (DoC):

The labelling requirements for a device subject to the DoC procedure are specified in Section 15.19(b). The label should include the FCC logo along with the Trade Name and Model Number, which satisfies the unique identifier requirement of Section 2.1074 if it represents the identical equipment tested for DoC compliance. For personal computers assembled from authorized components, the following additional text must also be included: “Assembled from tested components,” “Complete system not tested.” When the device is so small and/or when it is not practical to place the required additional text on the device, the text may be placed in the user manual or pamphlet supplied to the user. However, the FCC logo, Trade Name, and Model Number must still be displayed on the device (Section 15.19(b)(3)).



Part 15 Declaration of Conformity (DoC) Label Examples

Equipment certified as software defined radio may use a means that readily displays the FCC ID on an electronic display screen, instead of labelling the device (Section 2.925 (e)).

Further information may refer to FCC KDB:784748 D01 Labelling Part 15 &18 Guidelines

Labelling Requirements for ICES-003 Devices:

➤ Industry Canada ICES-003 Compliance Label:

CAN ICES-3 ()/NMB-3(*)*

* Insert either “A” or “B” but not both to identify the applicable Class of ITE.

4 Configuration and Connections with EUT

For Conducted/Radiated test Mode 1:

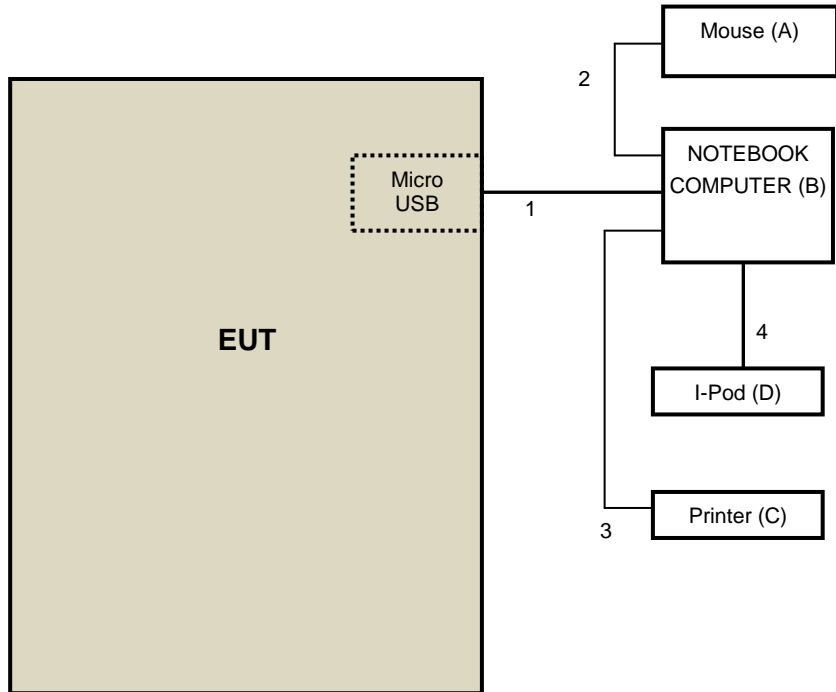

For Conducted test Mode 2 :

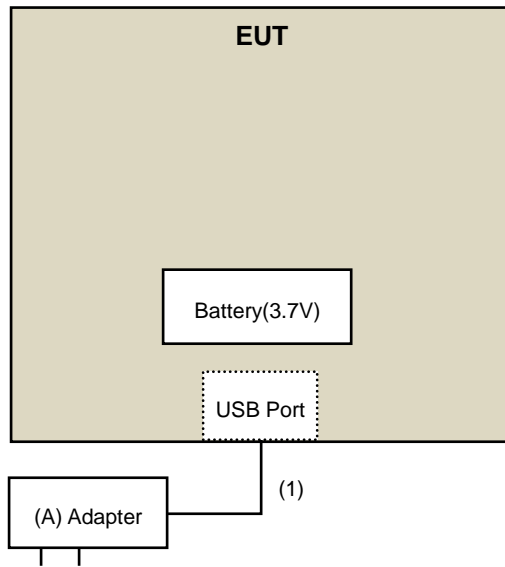

4.1 Configuration of Peripheral Devices and Cable Connections

For conducted test mode 2

ID	Product	Brand	Model No.	Serial No.	FCC ID	Remarks
A.	USB ADAPTER	ASUS	EXA1205UA	NA	NA	Provided by Lab

Note:

1. All power cords of the above support units are non-shielded (1.8m).

ID	Descriptions	Qty.	Length (m)	Shielding (Yes/No)	Cores (Qty.)	Remarks
1.	USB	1	1	Yes	0	Supplied by client

For other test items

ID	Product	Brand	Model No.	Serial No.	FCC ID	Remarks
A.	Mouse	DELL	MOC5UO	I1401MMP	FCC DoC	Provided by Lab
B.	NOTEBOOK COMPUTER	DELL	PP32LA	HSLB32S	FCC DoC	Provided by Lab
C.	Printer	EPSON	LQ-300+II	G88Y074083	FCC DoC	Provided by Lab
D.	I-Pod	Apple	MD778TA/A	CC4JMH7LF4T1	NA	Provided by Lab

Note:

1. All power cords of the above support units are non-shielded (1.8m).

ID	Descriptions	Qty.	Length (m)	Shielding (Yes/No)	Cores (Qty.)	Remarks
1.	USB	1	1	YES	2	Supplied by Client
2.	USB	1	1.8	YES	1	Provided by Lab
3.	USB	1	1.8	YES	0	Provided by Lab
4.	USB	1	0.1	YES	0	Provided by Lab

Note:

1. All power cords of the above support units are non-shielded (1.8m).

5 Conducted Emissions at Mains Ports

5.1 Limits

Frequency (MHz)	Class A (dBuV)		Class B (dBuV)	
	Quasi-peak	Average	Quasi-peak	Average
0.15 - 0.5	79	66	66 - 56	56 - 46
0.50 - 5.0	73	60	56	46
5.0 - 30.0	73	60	60	50

Notes: 1. The lower limit shall apply at the transition frequencies.
 2. The limit decreases linearly with the logarithm of the frequency in the range of 0.15 to 0.50 MHz.

5.2 Test Instruments

For test Mode 1:

DESCRIPTION & MANUFACTURER	MODEL NO.	SERIAL NO.	CALIBRATED DATE	CALIBRATED UNTIL
Test Receiver R&S	ESCS 30	100375	May 06, 2015	May 05, 2016
Line-Impedance Stabilization Network (for EUT) SCHWARZBECK	NSLK-8127	8127-522	Sep. 01, 2015	Aug. 31, 2016
Line-Impedance Stabilization Network (for Peripheral) R&S	ENV216	100072	June 11, 2015	June 10, 2016
RF Cable	5D-FB	COCCAB-001	Mar. 08, 2016	Mar. 07, 2017
50 ohms Terminator	N/A	EMC-03	Sep. 23, 2015	Sep. 22, 2016
50 ohms Terminator	N/A	EMC-02	Oct. 01, 2015	Sep. 30, 2016
50 ohms Terminator	E1-011315	13	Dec. 11, 2015	Dec. 10, 2016
Software BVADT	BVADT_Cond_ V7.3.7.3	NA	NA	NA

Note:

1. The calibration interval of the above test instruments are 12 months and the calibrations are traceable to NML/ROC and NIST/USA.
2. The test was performed in Shielded Room No. C.
- 3 The VCCI Con C Registration No. is C-3611.
- 4 Tested Date: Apr. 23, 2016



For test Mode 2:

DESCRIPTION & MANUFACTURER	MODEL NO.	SERIAL NO.	CALIBRATED DATE	CALIBRATED UNTIL
Test Receiver R&S	ESCS 30	100375	May 09, 2016	May 08, 2017
Line-Impedance Stabilization Network (for EUT) SCHWARZBECK	NSLK-8127	8127-522	Sep. 01, 2015	Aug. 31, 2016
Line-Impedance Stabilization Network (for Peripheral) R&S	ENV216	100072	June 11, 2015	June 10, 2016
RF Cable	5D-FB	COCCAB-001	Mar. 08, 2016	Mar. 07, 2017
10 dB PAD Mini-Circuits	HAT-10+	CONATT-002	Sep. 14, 2015	Sep. 13, 2016
50 ohms Terminator	N/A	EMC-03	Sep. 23, 2015	Sep. 22, 2016
50 ohms Terminator	N/A	EMC-02	Oct. 01, 2015	Sep. 30, 2016
50 ohms Terminator	E1-011315	13	Dec. 11 2015	Dec. 10 2016
Software BVADT	BVADT_Cond_ V7.3.7.3	NA	NA	NA

Note:

1. The calibration interval of the above test instruments are 12 months and the calibrations are traceable to NML/ROC and NIST/USA.
2. The test was performed in Shielded Room No. C.
- 3 The VCCI Con C Registration No. is C-3611.
- 4 Tested Date: June 07, 2016

5.3 Test Arrangement

- The EUT was placed 0.4 meters from the conducting wall of the shielded room with EUT being connected to the power mains through a line impedance stabilization network (LISN). Other support units were connected to the power mains through another LISN. The two LISNs provide 50 Ohm/ 50uH of coupling impedance for the measuring instrument.
- Both lines of the power mains connected to the EUT were checked for maximum conducted interference.
- The test results of conducted emissions at mains ports are recorded of six worst margins for quasi-peak (mandatory) [and average (if necessary)] values against the limits at frequencies of interest unless the margin is 20 dB or greater.

Note: The resolution bandwidth and video bandwidth of test receiver is 9kHz for quasi-peak detection (QP) and average detection (AV) at frequency 0.15MHz-30MHz.

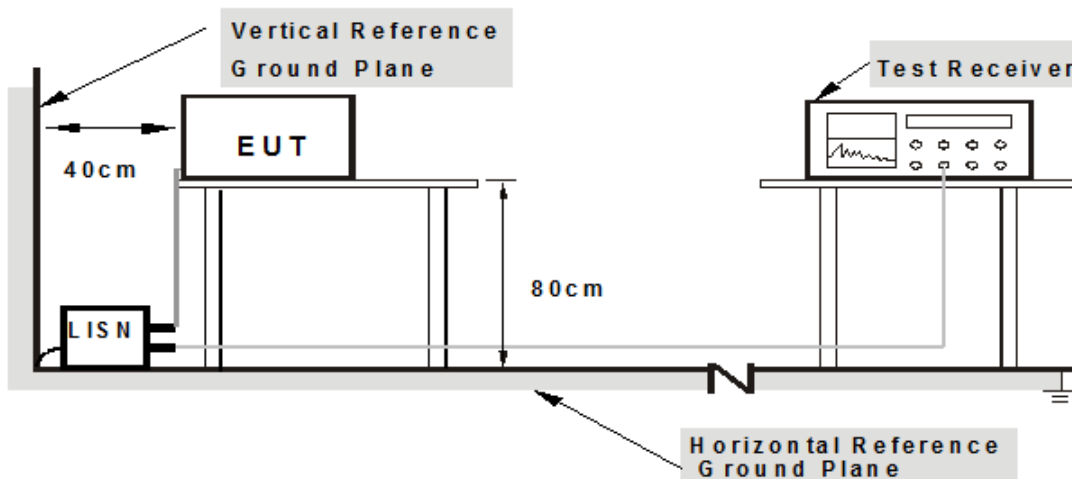

Note: 1. Support units were connected to second LISN.

For the actual test configuration, please refer to the related Item – Photographs of the Test Configuration.

5.4 Supplementary Information

There is not any deviation from the test standards for the test method.

5.6 Test Results (Mode1)

Frequency Range	150kHz ~ 30MHz	Detector Function & Bandwidth	Quasi-Peak (QP) / Average (AV), 9kHz
Input Power (system)	120Vac, 60Hz	Environmental Conditions	25°C, 76%RH
Tested by	Jason Huang		
Test Mode	Mode 1		

Phase Of Power : Line (L)										
No	Frequency (MHz)	Correction Factor (dB)	Reading Value (dBUV)		Emission Level (dBUV)		Limit (dBUV)		Margin (dB)	
			Q.P.	AV.	Q.P.	AV.	Q.P.	AV.	Q.P.	AV.
1	0.71641	10.26	18.99	11.97	29.25	22.23	56.00	46.00	-26.75	-23.77
2	0.81016	10.25	18.47	12.42	28.72	22.67	56.00	46.00	-27.28	-23.33
3	1.39844	10.24	14.42	7.55	24.66	17.79	56.00	46.00	-31.34	-28.21
4	2.35547	10.29	19.92	8.11	30.21	18.40	56.00	46.00	-25.79	-27.60
5	10.96875	10.59	13.23	7.23	23.82	17.82	60.00	50.00	-36.18	-32.18
6	17.55078	10.87	15.09	10.87	25.96	21.74	60.00	50.00	-34.04	-28.26

Remarks:

1. Q.P. and AV. are abbreviations of quasi-peak and average individually.
2. The emission levels of other frequencies were very low against the limit.
3. Margin value = Emission level – Limit value
4. Correction factor = Insertion loss + Cable loss
5. Emission Level = Correction Factor + Reading Value

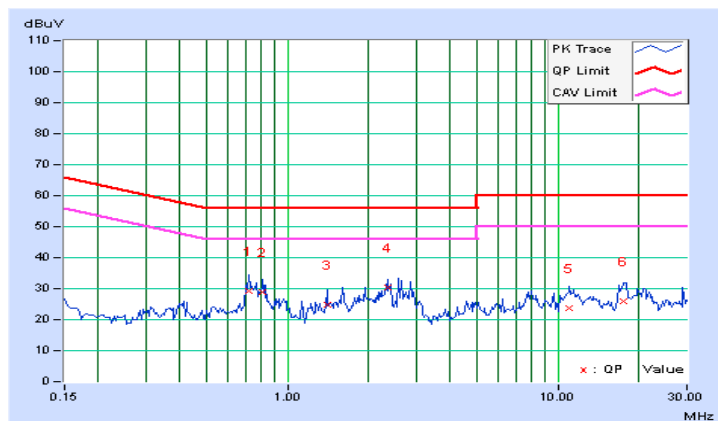

Frequency Range	150kHz ~ 30MHz	Detector Function & Bandwidth	Quasi-Peak (QP) / Average (AV), 9kHz
Input Power (system)	120Vac, 60Hz	Environmental Conditions	25°C, 76%RH
Tested by	Jason Huang		
Test Mode	Mode 1		

Phase Of Power : Neutral (N)										
No	Frequency (MHz)	Correction Factor (dB)	Reading Value (dBuV)		Emission Level (dBuV)		Limit (dBuV)		Margin (dB)	
			Q.P.	AV.	Q.P.	AV.	Q.P.	AV.	Q.P.	AV.
1	0.74766	10.25	18.56	7.36	28.81	17.61	56.00	46.00	-27.19	-28.39
2	0.95078	10.22	19.94	6.53	30.16	16.75	56.00	46.00	-25.84	-29.25
3	2.43750	10.30	18.87	6.16	29.17	16.46	56.00	46.00	-26.83	-29.54
4	2.78516	10.33	20.97	7.31	31.30	17.64	56.00	46.00	-24.70	-28.36
5	8.85156	10.53	19.32	5.28	29.85	15.81	60.00	50.00	-30.15	-34.19
6	28.76563	11.20	11.83	0.78	23.03	11.98	60.00	50.00	-36.97	-38.02

Remarks:

1. Q.P. and AV. are abbreviations of quasi-peak and average individually.
2. The emission levels of other frequencies were very low against the limit.
3. Margin value = Emission level – Limit value
4. Correction factor = Insertion loss + Cable loss
5. Emission Level = Correction Factor + Reading Value

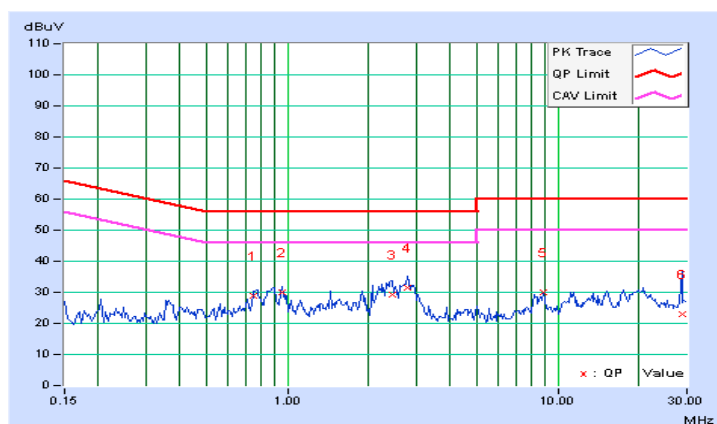

5.7 Test Results (Mode2)

Frequency Range	150kHz ~ 30MHz	Detector Function & Bandwidth	Quasi-Peak (QP) / Average (AV), 9kHz
Input Power	120Vac, 60Hz	Environmental Conditions	25°C, 68%RH
Tested by	Arthur Yang		
Test Mode	Mode 2		

Phase Of Power : Line (L)										
No	Frequency (MHz)	Correction Factor (dB)	Reading Value (dBuV)		Emission Level (dBuV)		Limit (dBuV)		Margin (dB)	
			Q.P.	AV.	Q.P.	AV.	Q.P.	AV.	Q.P.	AV.
1	0.15391	10.44	43.34	37.25	53.78	47.69	65.79	55.79	-12.01	-8.10
2	0.23594	10.41	38.82	28.09	49.23	38.50	62.24	52.24	-13.01	-13.74
3	0.61484	10.41	38.22	31.44	48.63	41.85	56.00	46.00	-7.37	-4.15
4	0.61484	10.41	37.94	31.53	48.35	41.94	56.00	46.00	-7.65	-4.06
5	0.70078	10.40	35.44	19.84	45.84	30.24	56.00	46.00	-10.16	-15.76
6	0.91172	10.39	29.61	17.68	40.00	28.07	56.00	46.00	-16.00	-17.93

Remarks:

1. Q.P. and AV. are abbreviations of quasi-peak and average individually.
2. The emission levels of other frequencies were very low against the limit.
3. Margin value = Emission level – Limit value
4. Correction factor = Insertion loss + Cable loss
5. Emission Level = Correction Factor + Reading Value

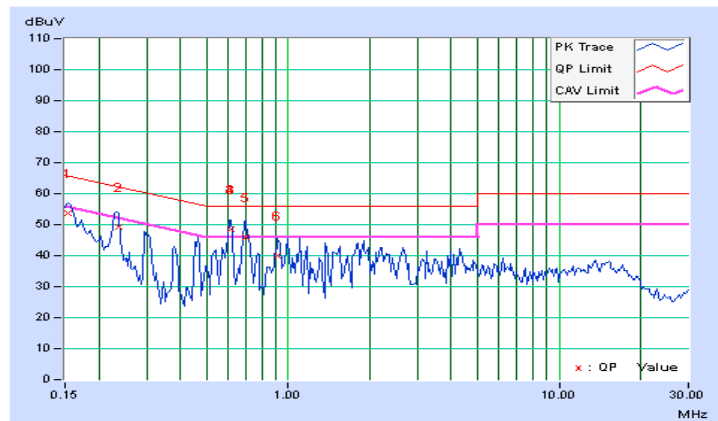

Frequency Range	150kHz ~ 30MHz	Detector Function & Bandwidth	Quasi-Peak (QP) / Average (AV), 9kHz
Input Power	120Vac, 60Hz	Environmental Conditions	25°C, 68%RH
Tested by	Arthur Yang		
Test Mode	Mode 2		

Phase Of Power : Neutral (N)										
No	Frequency (MHz)	Correction Factor (dB)	Reading Value (dBuV)		Emission Level (dBuV)		Limit (dBuV)		Margin (dB)	
			Q.P.	AV.	Q.P.	AV.	Q.P.	AV.	Q.P.	AV.
1	0.15391	10.45	41.87	28.89	52.32	39.34	65.79	55.79	-13.47	-16.45
2	0.23203	10.45	39.88	29.56	50.33	40.01	62.38	52.38	-12.05	-12.37
3	0.46250	10.47	29.30	19.98	39.77	30.45	56.65	46.65	-16.88	-16.20
4	0.60703	10.46	30.33	11.19	40.79	21.65	56.00	46.00	-15.21	-24.35
5	0.68906	10.46	31.07	20.20	41.53	30.66	56.00	46.00	-14.47	-15.34
6	1.46094	10.46	28.56	13.86	39.02	24.32	56.00	46.00	-16.98	-21.68

Remarks:

1. Q.P. and AV. are abbreviations of quasi-peak and average individually.
2. The emission levels of other frequencies were very low against the limit.
3. Margin value = Emission level – Limit value
4. Correction factor = Insertion loss + Cable loss
5. Emission Level = Correction Factor + Reading Value

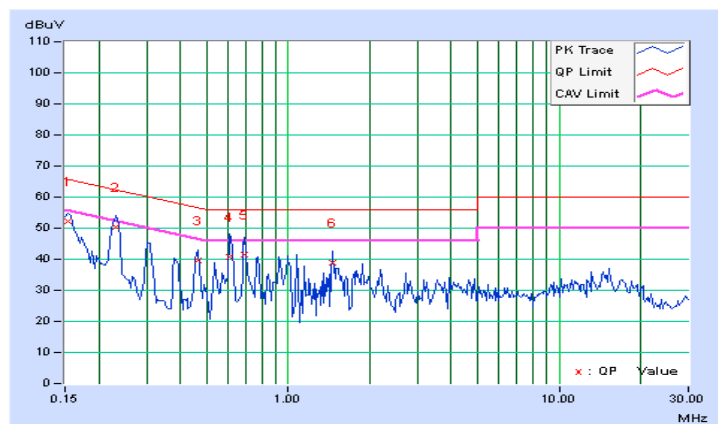

6 Radiated Emissions up to 1 GHz

6.1 Limits

Emissions radiated outside of the specified bands, shall be according to the general radiated limits as following:

Radiated Emissions Limits at 10 meters (dB μ V/m)				
Frequencies (MHz)	FCC 15B / ICES-003, Class A	FCC 15B / ICES-003, Class B	CISPR 22, Class A	CISPR 22, Class B
30-88	39	29.5	40	30
88-216	43.5	33.1		
216-230	46.4	35.6	47	37
230-960				
960-1000	49.5	43.5		

Radiated Emissions Limits at 3 meters (dB μ V/m)				
Frequencies (MHz)	FCC 15B / ICES-003, Class A	FCC 15B / ICES-003, Class B	CISPR 22, Class A	CISPR 22, Class B
30-88	49.5	40	50.5	40.5
88-216	54	43.5		
216-230	56.9	46	57.5	47.5
230-960				
960-1000	60	54		

- Notes:
1. The lower limit shall apply at the transition frequencies.
 2. Emission level (dB μ V/m) = 20 log Emission level (uV/m).
 3. QP detector shall be applied if not specified.



6.2 Test Instruments

DESCRIPTION & MANUFACTURER	MODEL NO.	SERIAL NO.	CALIBRATED DATE	CALIBRATED UNTIL
Test Receiver Agilent	N9038A	MY50010125	Apr. 16, 2016	Apr. 15, 2017
	N9038A	MY50010132	July 04, 2015	July 03, 2016
Pre-Amplifier Sonoma	310N	352925	Aug. 30, 2015	Aug. 29, 2016
	310N	352926	Aug. 30, 2015	Aug. 29, 2016
Trilog Broadband Antenna SCHWARZBECK	VULB 9168	9168-359	Jan. 05, 2016	Jan. 04, 2017
	VULB 9168	9168-358	Jan. 05, 2016	Jan. 04, 2017
Fixed attenuator Mini-Circuits	UNAT-5+	CHF-001	Sep. 10, 2015	Sep. 09, 2016
	UNAT-5+	CHF-002	Sep. 10, 2015	Sep. 09, 2016
RF Cable	8D-FB	CHFCAB-001-1 CHFCAB-001-3 CHFCAB-001-4	Sep. 23, 2015	Sep. 22, 2016
		CHFCAB-002-1 CHFCAB-002-3 CHFCAB-002-4	Sep. 23, 2015	Sep. 22, 2016
Software BVADT	ADT_Radiated_V 8.7.07	NA	NA	NA
Antenna Tower & Turn Table CT	NA	NA	NA	NA

Note:

1. The calibration interval of the above test instruments are 12 months and the calibrations are traceable to NML/ROC and NIST/USA.
2. The test was performed in 10m Chamber No. F.
3. The FCC Site Registration No. is 928149.
4. The VCCI Site Registration No. is R-3252-
5. The CANADA Site Registration No. is IC 7450H-1.
6. Tested Date: Apr. 26, 2016

6.3 Test Arrangement

- The EUT was placed on the top of a rotating table 0.8 meters above the ground at an accredited test facility. The table was rotated 360 degrees to determine the position of the highest radiation.
- The EUT was set 10 meters away from the interference-receiving antenna, which was mounted on the top of a variable-height antenna tower.
- The antenna is a broadband antenna, and its height is varied from one meter to four meters above the ground to determine the maximum value of the field strength. Both horizontal and vertical polarizations of the antenna are set to make the measurement.
- For each suspected emission, the EUT was arranged to its worst case and then the antenna was tuned to heights from 1 meter to 4 meters and the rotatable table was turned from 0 degrees to 360 degrees to find the maximum reading.
- The test-receiver system was set to quasi-peak detect function and specified bandwidth with maximum hold mode when the test frequency is up to 1 GHz.

Note: The resolution bandwidth and video bandwidth of test receiver/spectrum analyzer is 120kHz for quasi-peak detection (QP) at frequency up to 1GHz.

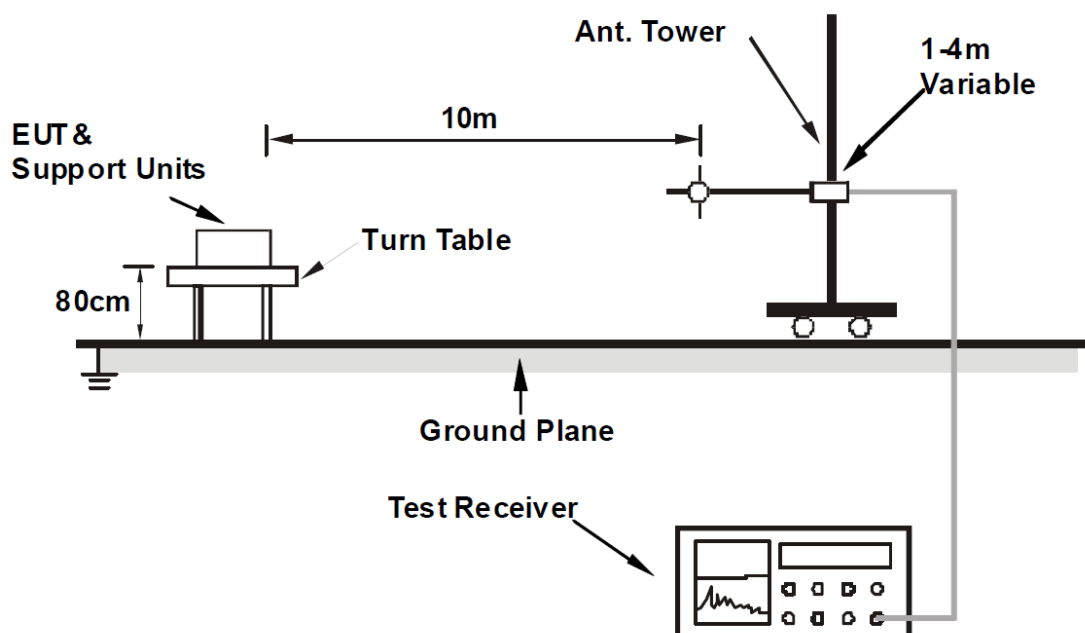

For the actual test configuration, please refer to the related Item – Photographs of the Test Configuration.

6.4 Supplementary Information

There is not any deviation from the test standards for the test method.

6.5 Test Results

Frequency Range	30MHz ~ 1GHz	Detector Function & Bandwidth	Quasi-Peak (QP), 120kHz
Input Power	5Vdc from host equipment	Environmental Conditions	25°C, 63%RH
Tested by	Wythe Lin		
Test Mode	Mode 1		

Antenna Polarity & Test Distance : Horizontal at 10 m								
No	Frequency (MHz)	Emission Level (dBuV/m)	Limit (dBuV/m)	Margin (dB)	Antenna Height (m)	Table Angle (Degree)	Raw Value (dBuV)	Correction Factor (dB/m)
1	33.57	20.34 QP	30.00	-9.66	4.00 H	28	34.10	-13.76
2	270.90	30.32 QP	37.00	-6.68	3.00 H	225	42.81	-12.49
3	421.30	27.63 QP	37.00	-9.37	2.00 H	359	35.85	-8.22
4	489.85	30.69 QP	37.00	-6.31	2.00 H	90	37.47	-6.78
5	661.30	33.31 QP	37.00	-3.69	1.00 H	62	36.65	-3.34
6	748.65	30.49 QP	37.00	-6.51	1.00 H	212	32.19	-1.70

Remarks:

1. Emission Level(dBuV/m) = Raw Value(dBuV) + Correction Factor(dB/m)
2. Correction Factor(dB/m) = Antenna Factor (dB/m) + Cable Factor (dB) – Pre-Amplifier Factor (dB)
3. The other emission levels were very low against the limit.
4. Margin value = Emission level – Limit value

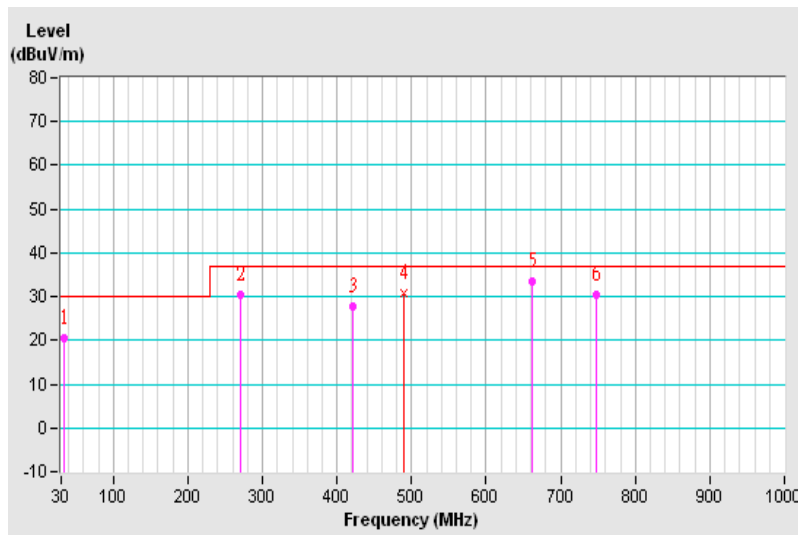

Frequency Range	30MHz ~ 1GHz	Detector Function & Bandwidth	Quasi-Peak (QP), 120kHz
Input Power	5Vdc from host equipment	Environmental Conditions	25°C, 63%RH
Tested by	Wythe Lin		
Test Mode	Mode 1		

Antenna Polarity & Test Distance : Vertical at 10 m

No	Frequency (MHz)	Emission Level (dBuV/m)	Limit (dBuV/m)	Margin (dB)	Antenna Height (m)	Table Angle (Degree)	Raw Value (dBuV)	Correction Factor (dB/m)
1	49.50	23.17 QP	30.00	-6.83	1.00 V	3	35.73	-12.56
2	177.32	25.67 QP	30.00	-4.33	2.00 V	100	39.08	-13.41
3	238.02	26.05 QP	37.00	-10.95	2.00 V	202	39.87	-13.82
4	492.95	26.76 QP	37.00	-10.24	1.00 V	181	33.15	-6.39
5	662.74	24.11 QP	37.00	-12.89	4.00 V	264	27.05	-2.94
6	749.90	33.67 QP	37.00	-3.33	3.00 V	204	34.87	-1.20

Remarks:

1. Emission Level(dBuV/m) = Raw Value(dBuV) + Correction Factor(dB/m)
2. Correction Factor(dB/m) = Antenna Factor (dB/m) + Cable Factor (dB) – Pre-Amplifier Factor (dB)
3. The other emission levels were very low against the limit.
4. Margin value = Emission level – Limit value

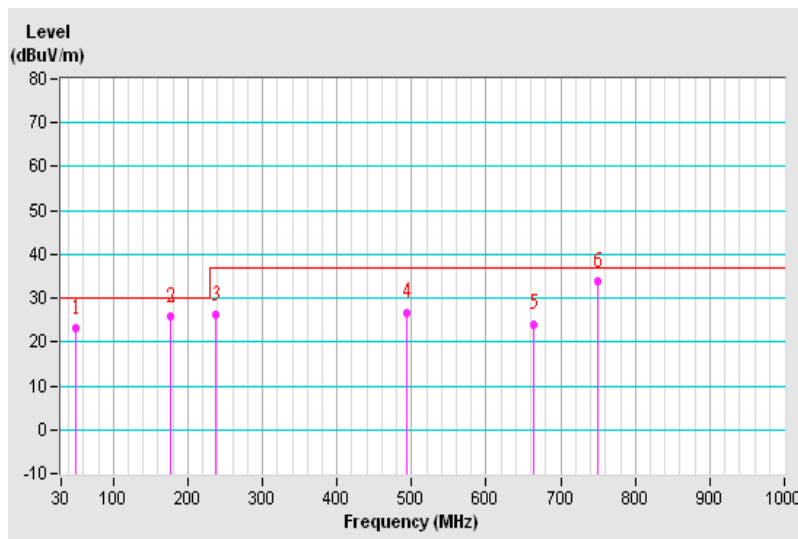

7 Radiated Emissions above 1 GHz

7.1 Limits

Emissions radiated outside of the specified bands, shall be according to the general radiated limits as following:

Radiated Emissions Limits at 10 meters (dB μ V/m)				
Frequencies (MHz)	FCC 15B / ICES-003, Class A	FCC 15B / ICES-003, Class B	CISPR 22, Class A	CISPR 22, Class B
1000-3000	Avg: 49.5	Avg: 43.5	Not defined	Not defined
Above 3000	Peak: 69.5	Peak: 63.5	Not defined	Not defined

Radiated Emissions Limits at 3 meters (dB μ V/m)				
Frequencies (MHz)	FCC 15B / ICES-003, Class A	FCC 15B / ICES-003, Class B	CISPR 22, Class A	CISPR 22, Class B
1000-3000	Avg: 60	Avg: 54	Avg: 56 Peak: 76	Avg: 50 Peak: 70
Above 3000	Peak: 80	Peak: 74	Avg: 60 Peak: 80	Avg: 54 Peak: 74

- Notes: 1. The lower limit shall apply at the transition frequencies.
 2. Emission level (dB μ V/m) = 20 log Emission level (uV/m).
 3. As shown in 15.35(b), for frequencies above 1000MHz, the field strength limits are based on average detector, however, the peak field strength of any emission shall not exceed the maximum permitted average limits, specified above by more than 20dB under any condition of modulation.

Frequency Range (For unintentional radiators)

Highest frequency generated or used in the device or on which the device operates or tunes (MHz)	Upper frequency of measurement range (MHz)
Below 1.705	30
1.705-108	1000
108-500	2000
500-1000	5000
Above 1000	5th harmonic of the highest frequency or 40GHz, whichever is lower

7.2 Test Instruments

DESCRIPTION & MANUFACTURER	MODEL NO.	SERIAL NO.	CALIBRATED DATE	CALIBRATED UNTIL
Test Receiver Agilent	N9038A	MY50010125	Apr. 16, 2016	Apr. 15, 2017
Pre-Amplifier Agilent	8449B	3008A01975	Feb. 27, 2016	Feb. 26, 2017
Horn Antenna SCHWARZBECK	BBHA 9120D	D123	Jan. 18, 2016	Jan. 17, 2017
RF Cable	SUCOFLEX104	RF-104-209 RF-104-110	Dec. 10, 2015	Dec.09, 2016
RF Cable	104 RF cable	131221	Dec. 10, 2015	Dec.09, 2016
Software BVADT	ADT_Radiated_ V8.7.07	NA	NA	NA
Antenna Tower & Turn Table CT	NA	NA	NA	NA

Note:

1. The calibration interval of the above test instruments are 12 months and the calibrations are traceable to NML/ROC and NIST/USA.
2. The test was performed in 10m Chamber No. F.
3. The VCCI Site Registration No. is G-136.
4. The 3dB beamwidth of the horn antenna is minimum 30 degree (or $w = 1.6m$ at 3m distance) for 1~6 GHz.
5. Tested Date: Apr. 26. 2016

7.3 Test Arrangement

- The EUT was placed on the top of a rotating table 0.8 meters above the ground at an accredited chamber room. The table was rotated 360 degrees to determine the position of the highest radiation.
- The EUT was set 3 meters away from the interference-receiving antenna, which was mounted on the top of a variable-height antenna tower.
- The height of antenna can be varied from one meter to four meters, the height of adjustment depends on the EUT height and the antenna 3dB beamwidth both, to detect the maximum value of the field strength. Both horizontal and vertical polarizations of the antenna are set to make the measurement.
- For each suspected emission, the EUT was arranged to its worst case and then the antenna was tuned to heights and the rotatable table was turned from 0 degrees to 360 degrees to find the maximum reading.
- The spectrum analyzer system was set to peak and average detect function and specified bandwidth with maximum hold mode when the test frequency is above 1 GHz.

Note: The resolution bandwidth of test receiver/spectrum analyzer is 1MHz and video bandwidth is 3MHz for Peak detection (PK) at frequency above 1GHz. The resolution bandwidth of test receiver/spectrum analyzer is 1 MHz for Average detection (AV) at frequency above 1GHz.

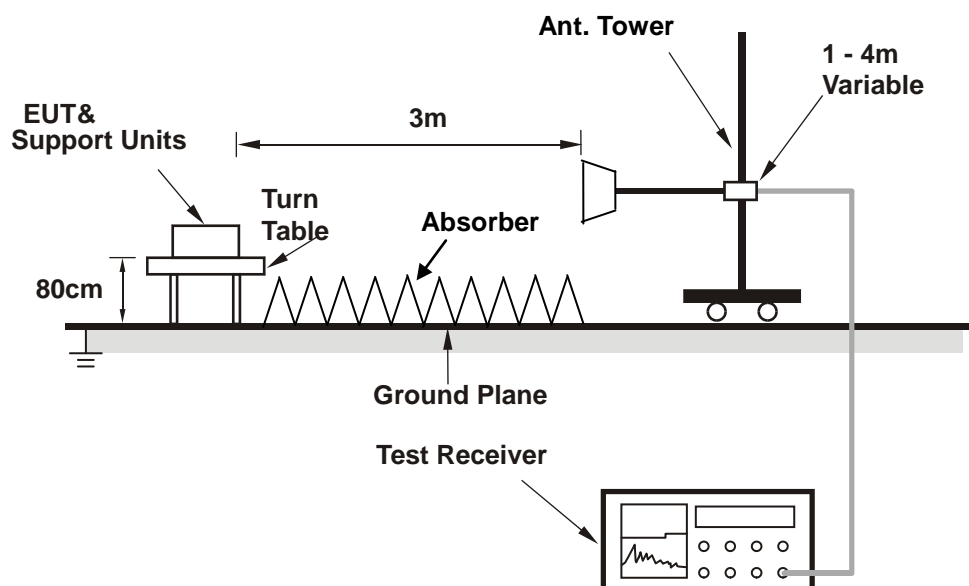

7.4 Supplementary Information

There is not any deviation from the test standards for the test method.

7.5 Test Results

Frequency Range	1GHz~12.5GHz	Detector Function & Bandwidth	Peak (PK) / Average (AV), 1MHz
Input Power	5Vdc from host equipment	Environmental Conditions	26°C, 65%RH
Tested by	Wythe Lin		
Test Mode	Mode 1		

Antenna Polarity & Test Distance : Horizontal at 3 m								
No	Frequency (MHz)	Emission Level (dBuV/m)	Limit (dBuV/m)	Margin (dB)	Antenna Height (m)	Table Angle (Degree)	Raw Value (dBuV)	Correction Factor (dB/m)
1	1200.52	48.37 PK	70.00	-21.63	1.00 H	118	51.61	-3.24
2	1200.52	25.36 AV	50.00	-24.64	1.00 H	118	28.60	-3.24
3	1597.10	45.32 PK	70.00	-24.68	1.00 H	101	46.75	-1.43
4	1597.10	26.55 AV	50.00	-23.45	1.00 H	101	27.98	-1.43
5	1793.32	43.14 PK	70.00	-26.86	1.00 H	97	43.45	-0.31
6	1793.32	26.89 AV	50.00	-23.11	1.00 H	97	27.20	-0.31
7	2000.52	46.71 PK	70.00	-23.29	1.00 H	165	46.11	0.60
8	2000.52	27.42 AV	50.00	-22.58	1.00 H	165	26.82	0.60
9	3326.11	43.53 PK	74.00	-30.47	1.00 H	162	38.32	5.21
10	3326.11	29.26 AV	54.00	-24.74	1.00 H	162	24.05	5.21
11	4639.24	46.71 PK	74.00	-27.29	1.00 H	157	36.92	9.79
12	4639.24	33.89 AV	54.00	-20.11	1.00 H	157	24.10	9.79

Remarks:

1. Emission Level(dBuV/m) = Raw Value(dBuV) + Correction Factor(dB/m)
2. Correction Factor(dB/m) = Antenna Factor (dB/m) + Cable Factor (dB) – Pre-Amplifier Factor (dB)
3. The other emission levels were very low against the limit.
4. Margin value = Emission level – Limit value

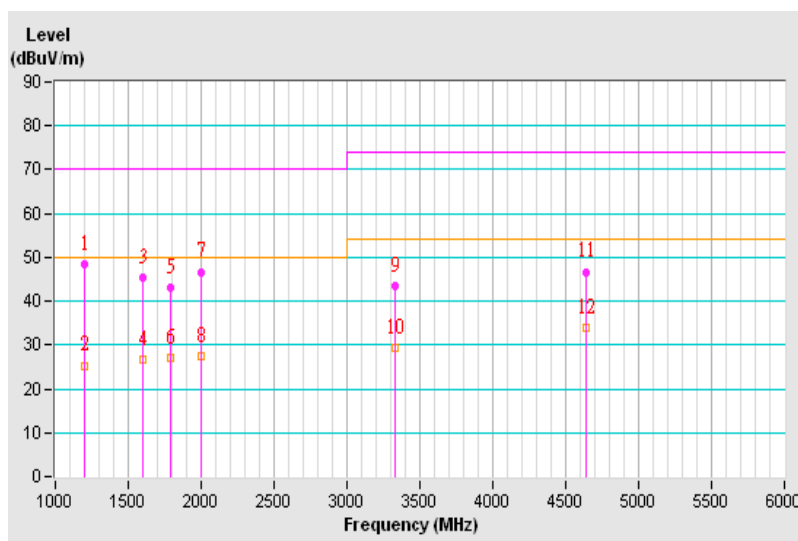

Frequency Range	1GHz~12.5GHz	Detector Function & Bandwidth	Peak (PK) / Average (AV), 1MHz
Input Power	5Vdc from host equipment	Environmental Conditions	26°C, 65%RH
Tested by	Wythe Lin		
Test Mode	Mode 1		

Antenna Polarity & Test Distance : Vertical at 3 m

No	Frequency (MHz)	Emission Level (dBuV/m)	Limit (dBuV/m)	Margin (dB)	Antenna Height (m)	Table Angle (Degree)	Raw Value (dBuV)	Correction Factor (dB/m)
1	1198.35	47.34 PK	70.00	-22.66	1.00 V	321	50.61	-3.27
2	1198.35	28.90 AV	50.00	-21.10	1.00 V	321	32.17	-3.27
3	1400.72	43.34 PK	70.00	-26.66	1.00 V	16	45.65	-2.31
4	1400.72	26.23 AV	50.00	-23.77	1.00 V	16	28.54	-2.31
5	1599.41	46.11 PK	70.00	-23.89	1.00 V	158	47.52	-1.41
6	1599.41	26.76 AV	50.00	-23.24	1.00 V	158	28.17	-1.41
7	1990.47	49.21 PK	70.00	-20.79	1.00 V	25	48.66	0.55
8	1990.47	29.54 AV	50.00	-20.46	1.00 V	25	28.99	0.55
9	4000.37	44.54 PK	74.00	-29.46	1.00 V	189	36.76	7.78
10	4000.37	31.72 AV	54.00	-22.28	1.00 V	189	23.94	7.78
11	4683.13	45.13 PK	74.00	-28.87	1.00 V	118	35.26	9.87
12	4683.13	32.46 AV	54.00	-21.54	1.00 V	118	22.59	9.87

Remarks:

1. Emission Level(dBuV/m) = Raw Value(dBuV) + Correction Factor(dB/m)
2. Correction Factor(dB/m) = Antenna Factor (dB/m) + Cable Factor (dB) – Pre-Amplifier Factor (dB)
3. The other emission levels were very low against the limit.
4. Margin value = Emission level – Limit value

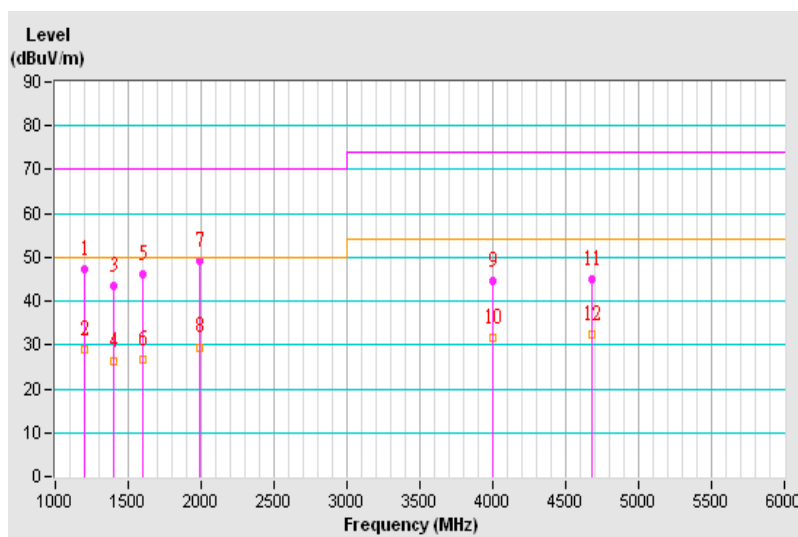



Appendix – Information on the Testing Laboratories

We, Bureau Veritas Consumer Products Services (H.K.) Ltd., Taoyuan Branch, were founded in 1988 to provide our best service in EMC, Radio, Telecom and Safety consultation. Our laboratories are accredited and approved according to ISO/IEC 17025.

If you have any comments, please feel free to contact us at the following:

Linko EMC/RF Lab

Tel: 886-2-26052180

Fax: 886-2-26051924

Hsin Chu EMC/RF/Telecom Lab

Tel: 886-3-6668565

Fax: 886-3-6668323

Hwa Ya EMC/RF/Safety Lab

Tel: 886-3-3183232

Fax: 886-3-3270892

Email: service.adt@tw.bureauveritas.com

Web Site: www.bureauveritas-adt.com

The address and road map of all our labs can be found in our web site also.

--- END ---