



A D T

FCC Test Report

Report No.: RF160413E14

FCC ID: NOIKBN236

Test Model: N236

Received Date: Apr. 13, 2016

Test Date: Apr. 15 to June 07, 2016

Issued Date: June 08, 2016

Applicant: NETRONIX, INC.

Address: No. 945, Boai St., Jubei City, Hsin-Chu,302,Taiwan, R.O.C.

Issued By: Bureau Veritas Consumer Products Services (H.K.) Ltd., Taoyuan Branch
Hsin Chu Laboratory

Lab Address: E-2, No.1, Li Hsin 1st Road, Hsinchu Science Park, Hsinchu City 300,
Taiwan R.O.C.

Test Location (1): E-2, No.1, Li Hsin 1st Road, Hsinchu Science Park, Hsinchu City 300,
Taiwan R.O.C.

Test Location (2): No. 49, Ln. 206, Wende Rd., Shangshan Tsuen, Chiung Lin Hsiang, Hsin
Chu Hsien 307, Taiwan R.O.C.



This report is for your exclusive use. Any copying or replication of this report to or for any other person or entity, or use of our name or trademark, is permitted only with our prior written permission. This report sets forth our findings solely with respect to the test samples identified herein. The results set forth in this report are not indicative or representative of the quality or characteristics of the lot from which a test sample was taken or any similar or identical product unless specifically and expressly noted. Our report includes all of the tests requested by you and the results thereof based upon the information that you provided to us. You have 60 days from date of issuance of this report to notify us of any material error or omission caused by our negligence, provided, however, that such notice shall be in writing and shall specifically address the issue you wish to raise. A failure to raise such issue within the prescribed time shall constitute your unqualified acceptance of the completeness of this report, the tests conducted and the correctness of the report contents. Unless specific mention, the uncertainty of measurement has been explicitly taken into account to declare the compliance or non-compliance to the specification. The report must not be used by the client to claim product certification, approval, or endorsement by TAF or any government agencies.

Table of Contents

Release Control Record	4
1 Certificate of Conformity	5
2 Summary of Test Results	6
2.1 Measurement Uncertainty	6
2.2 Modification Record	6
3 General Information	7
3.1 General Description of EUT	7
3.2 Description of Test Modes	8
3.2.1 Test Mode Applicability and Tested Channel Detail	9
3.3 Duty Cycle of Test Signal	11
3.4 Description of Support Units	12
3.4.1 Configuration of System under Test	13
3.5 General Description of Applied Standards	15
4 Test Types and Results	16
4.1 Radiated Emission and Bandedge Measurement	16
4.1.1 Limits of Radiated Emission and Bandedge Measurement	16
4.1.2 Test Instruments	17
4.1.3 Test Procedures	18
4.1.4 Deviation from Test Standard	18
4.1.5 Test Setup	19
4.1.6 EUT Operating Conditions	20
4.1.7 Test Results	21
4.2 Conducted Emission Measurement	31
4.2.1 Limits of Conducted Emission Measurement	31
4.2.2 Test Instruments	31
4.2.3 Test Procedures	32
4.2.4 Deviation from Test Standard	32
4.2.5 Test Setup	32
4.2.6 EUT Operating Conditions	32
4.2.7 Test Results (Mode 1)	33
4.2.8 Test Results (Mode 2)	35
4.3 6dB Bandwidth Measurement	37
4.3.1 Limits of 6dB Bandwidth Measurement	37
4.3.2 Test Setup	37
4.3.3 Test Instruments	37
4.3.4 Test Procedure	37
4.3.5 Deviation from Test Standard	37
4.3.6 EUT Operating Conditions	37
4.3.7 Test Result	38
4.4 Conducted Output Power Measurement	40
4.4.1 Limits of Conducted Output Power Measurement	40
4.4.2 Test Setup	40
4.4.3 Test Instruments	40
4.4.4 Test Procedures	40
4.4.5 Deviation from Test Standard	40
4.4.6 EUT Operating Conditions	40
4.4.7 Test Results	41
4.5 Power Spectral Density Measurement	43
4.5.1 Limits of Power Spectral Density Measurement	43
4.5.2 Test Setup	43
4.5.3 Test Instruments	43
4.5.4 Test Procedure	43
4.5.5 Deviation from Test Standard	43



4.5.6 EUT Operating Condition	43
4.5.7 Test Results	44
4.6 Conducted Out of Band Emission Measurement	46
4.6.1 Limits of Conducted Out of Band Emission Measurement.....	46
4.6.2 Test Setup.....	46
4.6.3 Test Instruments	46
4.6.4 Test Procedure	46
4.6.5 Deviation from Test Standard	46
4.6.6 EUT Operating Condition	46
4.6.7 Test Results	47
5 Pictures of Test Arrangements.....	51
Appendix – Information on the Testing Laboratories	52



A D T

Release Control Record

Issue No.	Description	Date Issued
RF160413E14	Original release.	June 08, 2016



1 Certificate of Conformity

Product: 6 inch Electronic Display Device
Brand: Kobo
Test Model: N236
Sample Status: ENGINEERING SAMPLE
Applicant: NETRONIX, INC.
Test Date: Apr. 15 to June 07, 2016
Standards: 47 CFR FCC Part 15, Subpart C (Section 15.247)
ANSI C63.10: 2013

The above equipment has been tested by **Bureau Veritas Consumer Products Services (H.K.) Ltd., Taoyuan Branch**, and found compliance with the requirement of the above standards. The test record, data evaluation & Equipment Under Test (EUT) configurations represented herein are true and accurate accounts of the measurements of the sample's EMC characteristics under the conditions specified in this report.

Prepared by :  _____, **Date:** _____ June 08, 2016
Claire Kuan / Specialist

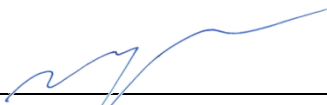
Approved by :  _____, **Date:** _____ June 08, 2016
May Chen / Manager

2 Summary of Test Results

47 CFR FCC Part 15, Subpart C (SECTION 15.247)			
FCC Clause	Test Item	Result	Remarks
15.207	AC Power Conducted Emission	PASS	Meet the requirement of limit. Minimum passing margin is -16.70dB at 0.66953MHz.
15.205 / 15.209 / 15.247(d)	Radiated Emissions and Band Edge Measurement	PASS	Meet the requirement of limit. Minimum passing margin is -0.2dB at 2483.50MHz
15.247(d)	Antenna Port Emission	PASS	Meet the requirement of limit.
15.247(a)(2)	6dB bandwidth	PASS	Meet the requirement of limit.
15.247(b)	Conducted power	PASS	Meet the requirement of limit.
15.247(e)	Power Spectral Density	PASS	Meet the requirement of limit.
15.203	Antenna Requirement	PASS	Antenna connector is soldering terminal not a standard connector.

2.1 Measurement Uncertainty

Where relevant, the following measurement uncertainty levels have been estimated for tests performed on the EUT as specified in CISPR 16-4-2:

Measurement	Frequency	Expanded Uncertainty (k=2) (±)
Conducted Emissions at mains ports	150kHz ~ 30MHz	1.83 dB
Radiated Emissions up to 1 GHz	30MHz ~ 1GHz	5.43 dB
Radiated Emissions above 1 GHz	1GHz ~ 6GHz	3.72 dB
	6GHz ~ 18GHz	4.00 dB
	18GHz ~ 40GHz	4.11 dB

2.2 Modification Record

There were no modifications required for compliance.

3 General Information

3.1 General Description of EUT

Product	6 inch Electronic Display Device
Brand	Kobo
Test Model	N236
Status of EUT	ENGINEERING SAMPLE
Power Supply Rating	3.7Vdc from battery or 5Vdc from host equipment
Modulation Type	CCK, DQPSK, DBPSK for DSSS 64QAM, 16QAM, QPSK, BPSK for OFDM
Modulation Technology	DSSS, OFDM
Transfer Rate	802.11b: up to 11Mbps 802.11g: up to 54Mbps 802.11n: up to 72.2Mbps
Operating Frequency	2.412 ~ 2.462GHz
Number of Channel	11
Output Power	802.11b: 96.605mW 802.11g: 239.883mW 802.11n (HT20): 234.423mW
Antenna Type	Refer to Note
Antenna Connector	Refer to Note
Accessory Device	NA
Data Cable Supplied	USB cable (Shielded, 1m) x 1

Note:

1. The EUT must be supplied with a rechargeable battery as following table:

Brand	Model No.	Spec.
SPRINGPOWER TECHNOLOGY	SP 285083	DC: 3.7V, 1500mAh, 5.55 Wh

2. The antenna provided to the EUT, please refer to the following table:

Brand	Model	Ant. Gain (dBi)	Frequency range (GHz to GHz)	Antenna Type	Antenna Connector
Walsin Technology Corporation	RFECA3216060AAT	2	2.4~2.4835	Ceramic	soldering terminal

3. The EUT incorporates a SISO function.

MODULATION MODE	DATA RATE (MCS)	TX & RX CONFIGURATION	
802.11b	1 ~ 11Mbps	1TX	1RX
802.11g	6 ~ 54Mbps	1TX	1RX
802.11n (HT20)	MCS 0~7	1TX	1RX

4. The EUT was pre-tested in chamber under the following modes:

Pre-test Mode	Description
Mode A	Adapter mode
Mode B	battery mode

The worse radiated emission was found in **Mode A**. Therefore only the test data of the modes were recorded in this report.

5. When USB port is charging the rechargeable battery, the EUT has WiFi function under charging mode. And the USB port is connected to Host unit, the EUT WiFi function will be disabled.

6. The above EUT information is declared by manufacturer and for more detailed features description, please refer to the manufacturer's specifications or user's manual.

3.2 Description of Test Modes

11 channels are provided for 802.11b, 802.11g and 802.11n (HT20):

Channel	Frequency	Channel	Frequency
1	2412MHz	7	2442MHz
2	2417MHz	8	2447MHz
3	2422MHz	9	2452MHz
4	2427MHz	10	2457MHz
5	2432MHz	11	2462MHz
6	2437MHz		

3.2.1 Test Mode Applicability and Tested Channel Detail

EUT CONFIGURE MODE	APPLICABLE TO				DESCRIPTION
	RE \geq 1G	RE<1G	PLC	APCM	
1	√	√	√	√	Power from Adapter
2	-	-	√	-	Power from host equipment

Where RE \geq 1G: Radiated Emission above 1GHz & Bandedge Measurement
 RE<1G: Radiated Emission below 1GHz
 PLC: Power Line Conducted Emission
 APCM: Antenna Port Conducted Measurement

NOTE:1. The EUT had been pre-tested on the positioned of each 3 axis. The worst case was found when positioned on X-plane (for below 1GHz) and Y-plane(for above 1GHz).

Radiated Emission Test (Above 1GHz):

- Pre-Scan has been conducted to determine the worst-case mode from all possible combinations between available modulations, data rates and antenna ports (if EUT with antenna diversity architecture).
- Following channel(s) was (were) selected for the final test as listed below.

MODE	AVAILABLE CHANNEL	TESTED CHANNEL	MODULATION TECHNOLOGY	MODULATION TYPE	DATA RATE (Mbps)
802.11b	1 to 11	1, 6, 11	DSSS	DBPSK	1
802.11g	1 to 11	1, 6, 11	OFDM	BPSK	6
802.11n (HT20)	1 to 11	1, 6, 11	OFDM	BPSK	6.5

Radiated Emission Test (Below 1GHz):

- Pre-Scan has been conducted to determine the worst-case mode from all possible combinations between available modulations, data rates and antenna ports (if EUT with antenna diversity architecture).
- Following channel(s) was (were) selected for the final test as listed below.

MODE	AVAILABLE CHANNEL	TESTED CHANNEL	MODULATION TECHNOLOGY	MODULATION TYPE	DATA RATE (Mbps)
802.11g	1 to 11	1	OFDM	BPSK	6

Power Line Conducted Emission Test:

- Pre-Scan has been conducted to determine the worst-case mode from all possible combinations between available modulations, data rates and antenna ports (if EUT with antenna diversity architecture).
- Following channel(s) was (were) selected for the final test as listed below.

MODE	AVAILABLE CHANNEL	TESTED CHANNEL	MODULATION TECHNOLOGY	MODULATION TYPE	DATA RATE (Mbps)
802.11g	1 to 11	1	OFDM	BPSK	6

Antenna Port Conducted Measurement:

- This item includes all test value of each mode, but only includes spectrum plot of worst value of each mode.
- Pre-Scan has been conducted to determine the worst-case mode from all possible combinations between available modulations, data rates and antenna ports (if EUT with antenna diversity architecture).
- Following channel(s) was (were) selected for the final test as listed below.

MODE	AVAILABLE CHANNEL	TESTED CHANNEL	MODULATION TECHNOLOGY	MODULATION TYPE	DATA RATE (Mbps)
802.11b	1 to 11	1, 6, 11	DSSS	DBPSK	1
802.11g	1 to 11	1, 6, 11	OFDM	BPSK	6
802.11n (HT20)	1 to 11	1, 6, 11	OFDM	BPSK	6.5

Test Condition:

APPLICABLE TO	ENVIRONMENTAL CONDITIONS	INPUT POWER (SYSTEM)	TESTED BY
RE≥1G	25deg. C, 65%RH	120Vac, 60Hz	Jyunchun Lin
RE<1G	25deg. C, 69%RH	120Vac, 60Hz	Weiwei Lo
PLC	25deg. C, 79%RH	120Vac, 60Hz	Wythe Lin
APCM	22deg. C, 64%RH	120Vac, 60Hz	Anderson Chen

3.3 Duty Cycle of Test Signal

Duty cycle of test signal is 100 %, duty factor is not required.

802.11b **802.11g**

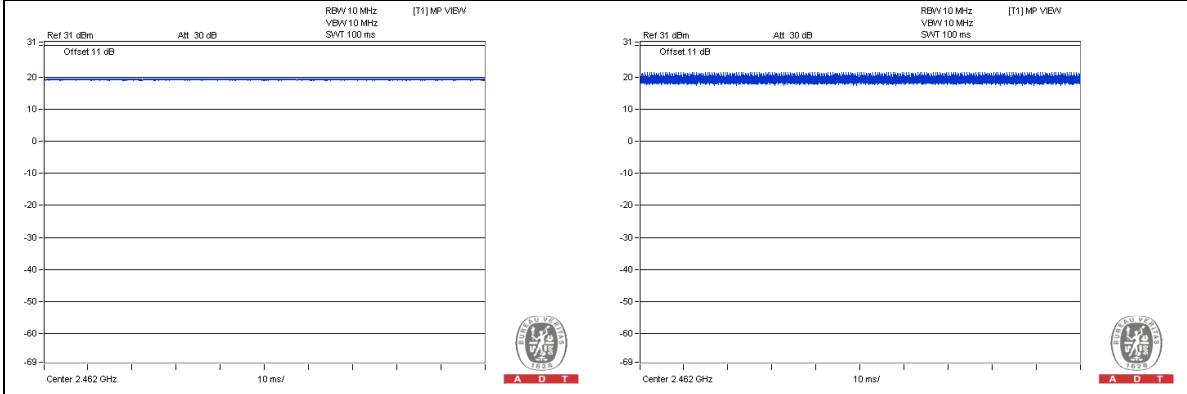

802.11n (HT20)

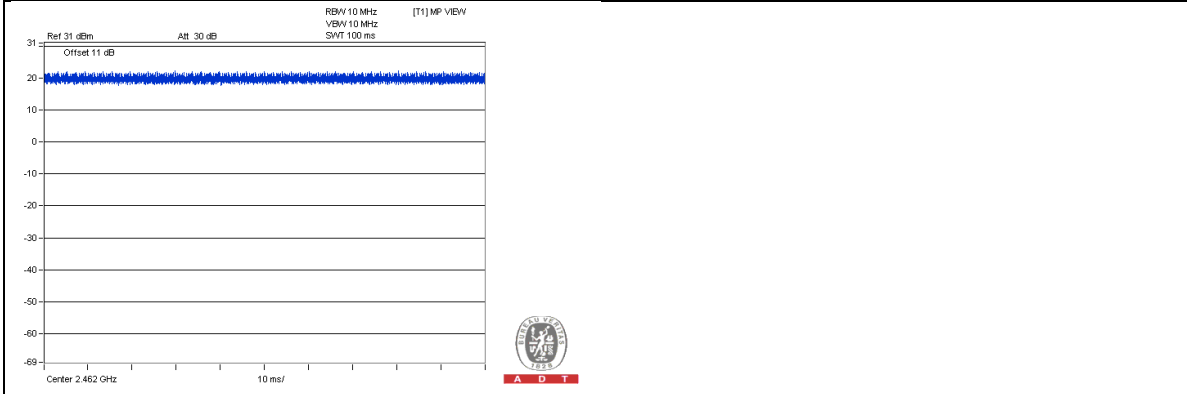

3.4 Description of Support Units

The EUT has been tested as an independent unit together with other necessary accessories or support units. The following support units or accessories were used to form a representative test configuration during the tests.

For conducted test mode 2						
ID	Product	Brand	Model No.	Serial No.	FCC ID	Remarks
A.	Mouse	DELL	MOC5UO	I1401MMP	FCC DoC	Provided by Lab
B.	NOTEBOOK COMPUTER	DELL	PP32LA	HSLB32S	FCC DoC	Provided by Lab
C.	Printer	EPSON	LQ-300+II	G88Y074083	FCC DoC	Provided by Lab
D.	I-Pod	Apple	MD778TA/A	CC4JMH7LF4T1	NA	Provided by Lab

Note:

1. All power cords of the above support units are non-shielded (1.8m).

ID	Descriptions	Qty.	Length (m)	Shielding (Yes/No)	Cores (Qty.)	Remarks
1.	USB	1	1	YES	2	Supplied by Client
2.	USB	1	1.8	YES	1	Provided by Lab
3.	USB	1	1.8	YES	0	Provided by Lab
4.	USB	1	0.1	YES	0	Provided by Lab

Note:

1. All power cords of the above support units are non-shielded (1.8m).

For other test items						
ID	Product	Brand	Model No.	Serial No.	FCC ID	Remarks
A.	USB ADAPTER	ASUS	EXA1205UA	NA	NA	Provided by Lab

Note:

1. All power cords of the above support units are non-shielded (1.8m).

ID	Descriptions	Qty.	Length (m)	Shielding (Yes/No)	Cores (Qty.)	Remarks
1.	USB	1	1	Yes	0	Supplied by client

3.4.1 Configuration of System under Test

For conducted test mode 2:

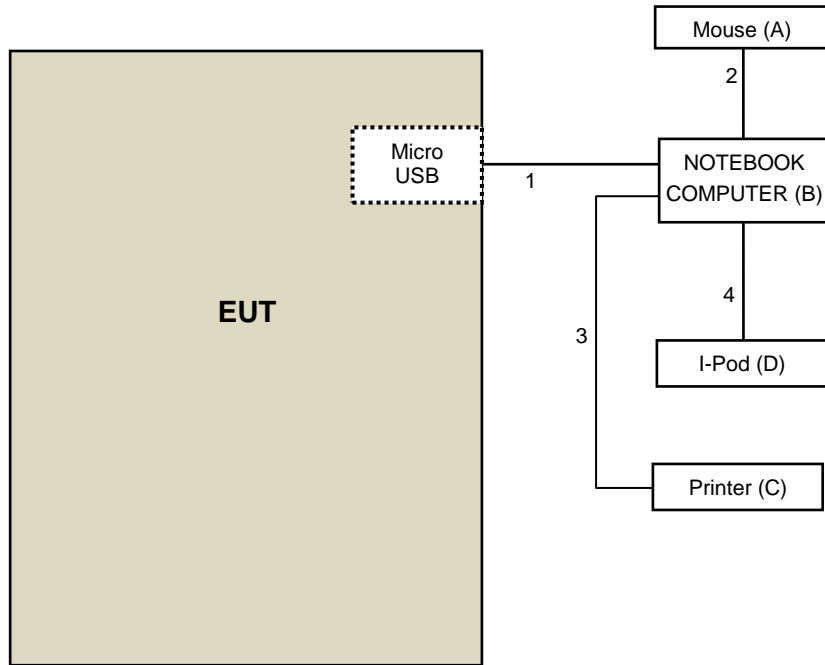

For other test items:

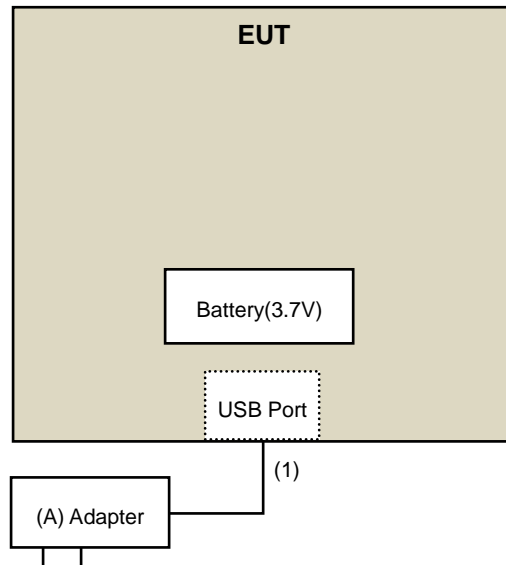

3.5 General Description of Applied Standards

The EUT is a RF Product. According to the specifications of the manufacturer, it must comply with the requirements of the following standards:

FCC Part 15, Subpart C (15.247)
KDB 558074 D01 DTS Meas Guidance v03r05
ANSI C63.10-2013

All test items have been performed and recorded as per the above standards.

NOTE: The EUT has been verified to comply with the requirements of FCC Part 15, Subpart B, Class B (DoC).
The test report has been issued separately.

4 Test Types and Results

4.1 Radiated Emission and Bandedge Measurement

4.1.1 Limits of Radiated Emission and Bandedge Measurement

Radiated emissions which fall in the restricted bands must comply with the radiated emission limits specified as below table. Other emissions shall be at least 20dB below the highest level of the desired power:

Frequencies (MHz)	Field Strength (microvolts/meter)	Measurement Distance (meters)
0.009 ~ 0.490	2400/F(kHz)	300
0.490 ~ 1.705	24000/F(kHz)	30
1.705 ~ 30.0	30	30
30 ~ 88	100	3
88 ~ 216	150	3
216 ~ 960	200	3
Above 960	500	3

NOTE:

1. The lower limit shall apply at the transition frequencies.
2. Emission level (dBuV/m) = 20 log Emission level (uV/m).
3. For frequencies above 1000MHz, the field strength limits are based on average detector, however, the peak field strength of any emission shall not exceed the maximum permitted average limits, specified above by more than 20dB under any condition of modulation.

4.1.2 Test Instruments

DESCRIPTION & MANUFACTURER	MODEL NO.	SERIAL NO.	CALIBRATED DATE	CALIBRATED UNTIL
Test Receiver Agilent	N9038A	MY51210202	Dec. 16, 2015	Dec. 15, 2016
Pre-Amplifier ^(*) EMCI	EMC001340	980142	Jan. 20, 2016	Jan. 19, 2018
Loop Antenna ^(*) Electro-Metrics	EM-6879	264	Dec. 16, 2014	Dec. 15, 2016
RF Cable	NA	LOOPCAB-001 LOOPCAB-002	Jan. 18, 2016	Jan. 17, 2017
Pre-Amplifier Mini-Circuits	ZFL-1000VH2 B	AMP-ZFL-04	Nov. 11, 2015	Nov. 10, 2016
Trilog Broadband Antenna SCHWARZBECK	VULB 9168	9168-361	Jan. 07, 2016	Jan. 06, 2017
RF Cable	8D-FB	CHHCAB-001-1 CHHCAB-001-2	Oct. 04, 2015	Oct. 03, 2016
	RF-141	CHHCAB-004	Oct. 04, 2015	Oct. 03, 2016
Horn_Antenna AISI	AIH.8018	0000220091110	Jan. 18, 2016	Jan. 17, 2017
Pre-Amplifier Agilent	8449B	3008A01923	Oct. 27, 2015	Oct. 26, 2016
RF Cable	NA	131206 131213 131215 SNMY23685/4	Jan. 15, 2016	Jan. 14, 2017
Spectrum Analyzer Agilent	E4446A	MY48250254	Nov. 25, 2015	Nov. 24, 2016
Pre-Amplifier SPACEK LABS	SLKKa-48-6	9K16	Dec. 11, 2015	Dec. 10, 2016
Horn_Antenna SCHWARZBECK	BBHA 9170	9170-424	Jan. 18, 2016	Jan. 17, 2017
RF Cable	SUCOFLEX 102	36442/2 36434/2	Dec. 10, 2015	Dec.09, 2016
Software	ADT_Radiated _V8.7.07	NA	NA	NA
Antenna Tower & Turn Table CT	NA	NA	NA	NA
Boresight Antenna Fixture	NA	NA	NA	NA
Power meter Anritsu	ML2495A	0824006	May 25, 2015	May 24, 2016
Power sensor Anritsu	MA2411B	0738172	May 25, 2015	May 24, 2016

Note:

1. The calibration interval of the above test instruments is 12 months and the calibrations are traceable to NML/ROC and NIST/USA.
2. The test was performed in 966 Chamber No. H.
3. The FCC Site Registration No. is 797305.
4. The CANADA Site Registration No. is IC 7450H-3.
5. Tested Date: Apr. 15 to 28, 2016

4.1.3 Test Procedures

- a. The EUT was placed on the top of a rotating table 0.8 meters (for below 1GHz) / 1.5 meters (for above 1GHz) above the ground at 3 meter chamber room for test. The table was rotated 360 degrees to determine the position of the highest radiation.
- b. The EUT was set 3 meters away from the interference-receiving antenna, which was mounted on the top of a variable-height antenna tower.
- c. The height of antenna is varied from one meter to four meters above the ground to determine the maximum value of the field strength. Both horizontal and vertical polarizations of the antenna are set to make the measurement.
- d. For each suspected emission, the EUT was arranged to its worst case and then the antenna was tuned to heights from 1 meter to 4 meters and the rotatable table was turned from 0 degrees to 360 degrees to find the maximum reading.
- e. The test-receiver system was set to quasi-peak detect function and specified bandwidth with maximum hold mode when the test frequency is below 1 GHz.
- f. The test-receiver system was set to peak and average detect function and specified bandwidth with maximum hold mode when the test frequency is above 1 GHz. If the peak reading value also meets average limit, measurement with the average detector is unnecessary.

Note:

1. The resolution bandwidth and video bandwidth of test receiver/spectrum analyzer is 120kHz for Quasi-peak detection (QP) at frequency below 1GHz.
2. The resolution bandwidth of test receiver/spectrum analyzer is 1 MHz and the video bandwidth is 3 MHz for Peak detection (PK) at frequency above 1GHz.
3. The resolution bandwidth of test receiver/spectrum analyzer is 1MHz and the video bandwidth is 3MHz for RMS Average (Duty cycle < 98%) for Average detection (AV) at frequency above 1GHz, then the measurement results was added to a correction factor ($10 \log(1/\text{duty cycle})$).
4. The resolution bandwidth of test receiver/spectrum analyzer is 1MHz and the video bandwidth is 10Hz (Duty cycle $\geq 98\%$) for Average detection (AV) at frequency above 1GHz.
5. All modes of operation were investigated and the worst-case emissions are reported.

4.1.4 Deviation from Test Standard

No deviation.

4.1.5 Test Setup

<Frequency Range below 1GHz>

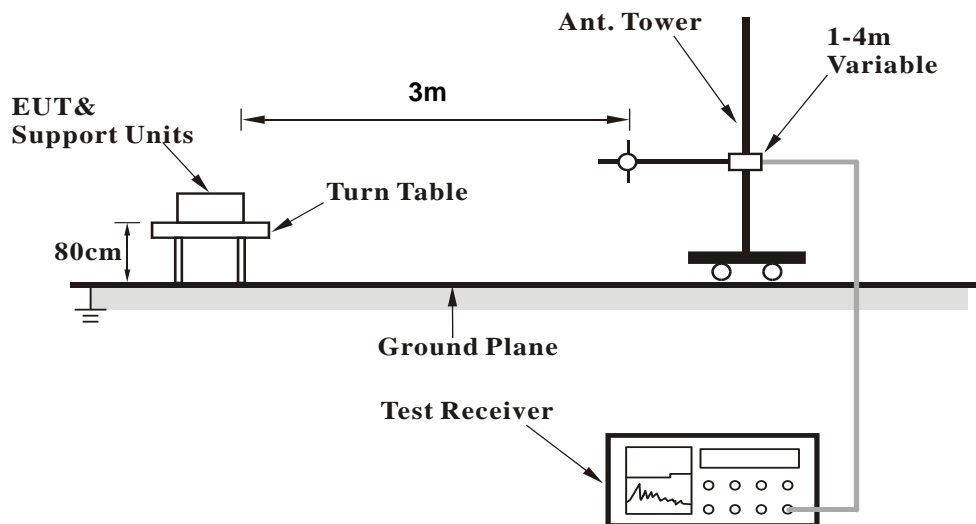

<Frequency Range above 1GHz>

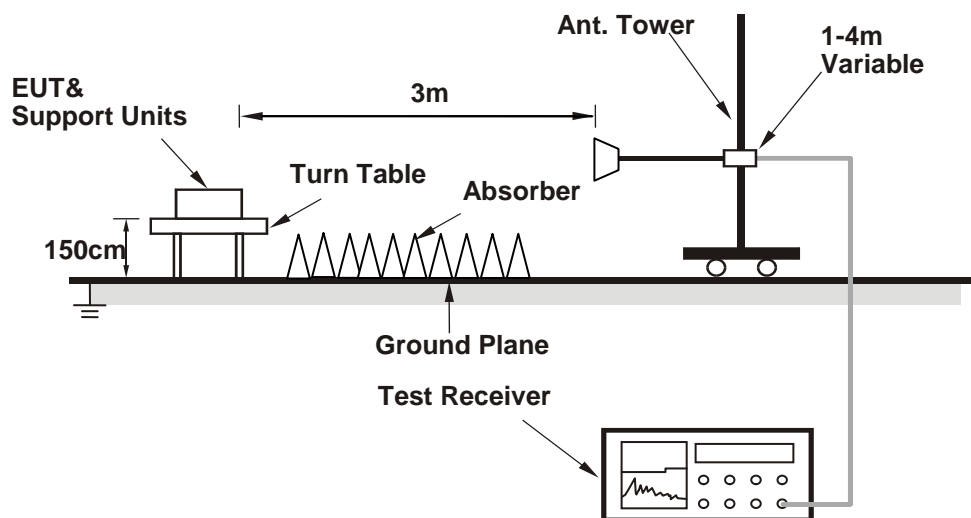

For the actual test configuration, please refer to the attached file (Test Setup Photo).

4.1.6 EUT Operating Conditions

1. Placed the EUT on testing table.
2. Controlling software (HyperTerminal paste MP.txt command) has been activated to set the EUT under transmission/receiving condition continuously.

4.1.7 Test Results

Above 1GHz Data :

802.11b

CHANNEL	TX Channel 1	DETECTOR FUNCTION	Peak (PK)
FREQUENCY RANGE	1GHz ~ 25GHz		Average (AV)

ANTENNA POLARITY & TEST DISTANCE: HORIZONTAL AT 3 M

NO.	FREQ. (MHz)	EMISSION LEVEL (dBuV/m)	LIMIT (dBuV/m)	MARGIN (dB)	ANTENNA HEIGHT (m)	TABLE ANGLE (Degree)	RAW VALUE (dBuV)	CORRECTION FACTOR (dB/m)
1	2390.00	55.0 PK	74.0	-19.0	1.77 H	164	56.88	-1.88
2	2390.00	43.3 AV	54.0	-10.7	1.77 H	164	45.18	-1.88
3	*2412.00	107.7 PK			1.77 H	164	109.53	-1.83
4	*2412.00	103.7 AV			1.77 H	164	105.53	-1.83
5	4824.00	55.1 PK	74.0	-18.9	1.79 H	228	48.43	6.67
6	4824.00	50.9 AV	54.0	-3.1	1.79 H	228	44.23	6.67

ANTENNA POLARITY & TEST DISTANCE: VERTICAL AT 3 M

NO.	FREQ. (MHz)	EMISSION LEVEL (dBuV/m)	LIMIT (dBuV/m)	MARGIN (dB)	ANTENNA HEIGHT (m)	TABLE ANGLE (Degree)	RAW VALUE (dBuV)	CORRECTION FACTOR (dB/m)
1	2390.00	55.5 PK	74.0	-18.5	1.81 V	91	57.38	-1.88
2	2390.00	43.0 AV	54.0	-11.0	1.81 V	91	44.88	-1.88
3	*2412.00	106.9 PK			1.81 V	91	108.73	-1.83
4	*2412.00	103.1 AV			1.81 V	91	104.93	-1.83
5	4824.00	54.8 PK	74.0	-19.2	1.80 V	348	48.13	6.67
6	4824.00	50.1 AV	54.0	-3.9	1.80 V	348	43.43	6.67

REMARKS:

1. Emission Level(dBuV/m) = Raw Value(dBuV) + Correction Factor(dB/m)
2. Correction Factor(dB/m) = Antenna Factor(dB/m) + Cable Factor(dB) – Pre-Amplifier Factor(dB)
3. The other emission levels were very low against the limit.
4. Margin value = Emission Level – Limit value
5. " * ": Fundamental frequency.

CHANNEL	TX Channel 6	DETECTOR FUNCTION	Peak (PK)
FREQUENCY RANGE	1GHz ~ 25GHz		Average (AV)

ANTENNA POLARITY & TEST DISTANCE: HORIZONTAL AT 3 M

NO.	FREQ. (MHz)	EMISSION LEVEL (dBuV/m)	LIMIT (dBuV/m)	MARGIN (dB)	ANTENNA HEIGHT (m)	TABLE ANGLE (Degree)	RAW VALUE (dBuV)	CORRECTION FACTOR (dB/m)
1	*2437.00	108.3 PK			1.58 H	173	110.11	-1.81
2	*2437.00	104.4 AV			1.58 H	173	106.21	-1.81
3	4874.00	54.5 PK	74.0	-19.5	1.59 H	131	47.67	6.83
4	4874.00	50.8 AV	54.0	-3.2	1.59 H	131	43.97	6.83
5	7311.00	58.0 PK	74.0	-16.0	1.56 H	128	46.86	11.14
6	7311.00	48.2 AV	54.0	-5.8	1.56 H	128	37.06	11.14

ANTENNA POLARITY & TEST DISTANCE: VERTICAL AT 3 M

NO.	FREQ. (MHz)	EMISSION LEVEL (dBuV/m)	LIMIT (dBuV/m)	MARGIN (dB)	ANTENNA HEIGHT (m)	TABLE ANGLE (Degree)	RAW VALUE (dBuV)	CORRECTION FACTOR (dB/m)
1	*2437.00	107.1 PK			1.76 V	90	108.91	-1.81
2	*2437.00	103.5 AV			1.76 V	90	105.31	-1.81
3	4874.00	54.3 PK	74.0	-19.7	1.58 V	210	47.47	6.83
4	4874.00	50.0 AV	54.0	-4.0	1.58 V	210	43.17	6.83
5	7311.00	56.8 PK	74.0	-17.2	1.45 V	197	45.66	11.14
6	7311.00	44.4 AV	54.0	-9.6	1.45 V	197	33.26	11.14

REMARKS:

1. Emission Level(dBuV/m) = Raw Value(dBuV) + Correction Factor(dB/m)
2. Correction Factor(dB/m) = Antenna Factor(dB/m) + Cable Factor(dB) – Pre-Amplifier Factor(dB)
3. The other emission levels were very low against the limit.
4. Margin value = Emission Level – Limit value
5. " * ": Fundamental frequency.

CHANNEL	TX Channel 11	DETECTOR FUNCTION	Peak (PK)
FREQUENCY RANGE	1GHz ~ 25GHz		Average (AV)

ANTENNA POLARITY & TEST DISTANCE: HORIZONTAL AT 3 M

NO.	FREQ. (MHz)	EMISSION LEVEL (dBuV/m)	LIMIT (dBuV/m)	MARGIN (dB)	ANTENNA HEIGHT (m)	TABLE ANGLE (Degree)	RAW VALUE (dBuV)	CORRECTION FACTOR (dB/m)
1	*2462.00	108.8 PK			1.78 H	170	110.60	-1.80
2	*2462.00	104.7 AV			1.78 H	170	106.50	-1.80
3	2483.50	56.1 PK	74.0	-17.9	1.78 H	170	57.89	-1.79
4	2483.50	44.1 AV	54.0	-9.9	1.78 H	170	45.89	-1.79
5	4924.00	55.0 PK	74.0	-19.0	1.76 H	111	48.09	6.91
6	4924.00	50.9 AV	54.0	-3.1	1.76 H	111	43.99	6.91
7	7386.00	58.5 PK	74.0	-15.5	1.57 H	165	46.93	11.57
8	7386.00	48.6 AV	54.0	-5.4	1.57 H	165	37.03	11.57

ANTENNA POLARITY & TEST DISTANCE: VERTICAL AT 3 M

NO.	FREQ. (MHz)	EMISSION LEVEL (dBuV/m)	LIMIT (dBuV/m)	MARGIN (dB)	ANTENNA HEIGHT (m)	TABLE ANGLE (Degree)	RAW VALUE (dBuV)	CORRECTION FACTOR (dB/m)
1	*2462.00	107.4 PK			1.74 V	90	109.20	-1.80
2	*2462.00	103.8 AV			1.74 V	90	105.60	-1.80
3	2483.50	55.8 PK	74.0	-18.2	1.74 V	90	57.59	-1.79
4	2483.50	43.5 AV	54.0	-10.5	1.74 V	90	45.29	-1.79
5	4924.00	54.9 PK	74.0	-19.1	1.56 V	194	47.99	6.91
6	4924.00	50.4 AV	54.0	-3.6	1.56 V	194	43.49	6.91
7	7386.00	57.2 PK	74.0	-16.8	1.93 V	187	45.63	11.57
8	7386.00	45.1 AV	54.0	-8.9	1.93 V	187	33.53	11.57

REMARKS:

1. Emission Level(dBuV/m) = Raw Value(dBuV) + Correction Factor(dB/m)
2. Correction Factor(dB/m) = Antenna Factor(dB/m) + Cable Factor(dB) – Pre-Amplifier Factor(dB)
3. The other emission levels were very low against the limit.
4. Margin value = Emission Level – Limit value
5. " * ": Fundamental frequency.

802.11g

CHANNEL	TX Channel 1	DETECTOR FUNCTION	Peak (PK)
FREQUENCY RANGE	1GHz ~ 25GHz		Average (AV)

ANTENNA POLARITY & TEST DISTANCE: HORIZONTAL AT 3 M								
NO.	FREQ. (MHz)	EMISSION LEVEL (dBuV/m)	LIMIT (dBuV/m)	MARGIN (dB)	ANTENNA HEIGHT (m)	TABLE ANGLE (Degree)	RAW VALUE (dBuV)	CORRECTION FACTOR (dB/m)
1	2390.00	66.7 PK	74.0	-7.3	1.69 H	164	68.58	-1.88
2	2390.00	50.5 AV	54.0	-3.5	1.69 H	164	52.38	-1.88
3	*2412.00	108.5 PK			1.69 H	164	110.33	-1.83
4	*2412.00	98.5 AV			1.69 H	164	100.33	-1.83
5	4824.00	52.9 PK	74.0	-21.1	1.63 H	110	46.23	6.67
6	4824.00	40.3 AV	54.0	-13.7	1.63 H	110	33.63	6.67

ANTENNA POLARITY & TEST DISTANCE: VERTICAL AT 3 M								
NO.	FREQ. (MHz)	EMISSION LEVEL (dBuV/m)	LIMIT (dBuV/m)	MARGIN (dB)	ANTENNA HEIGHT (m)	TABLE ANGLE (Degree)	RAW VALUE (dBuV)	CORRECTION FACTOR (dB/m)
1	2390.00	64.8 PK	74.0	-9.2	1.82 V	91	66.68	-1.88
2	2390.00	48.6 AV	54.0	-5.4	1.82 V	91	50.48	-1.88
3	*2412.00	106.2 PK			1.82 V	91	108.03	-1.83
4	*2412.00	96.9 AV			1.82 V	91	98.73	-1.83
5	4824.00	53.0 PK	74.0	-21.0	1.38 V	171	46.33	6.67
6	4824.00	39.7 AV	54.0	-14.3	1.38 V	171	33.03	6.67

REMARKS:

1. Emission Level(dBuV/m) = Raw Value(dBuV) + Correction Factor(dB/m)
2. Correction Factor(dB/m) = Antenna Factor(dB/m) + Cable Factor(dB) – Pre-Amplifier Factor(dB)
3. The other emission levels were very low against the limit.
4. Margin value = Emission Level – Limit value
5. " * ": Fundamental frequency.

CHANNEL	TX Channel 6	DETECTOR FUNCTION	Peak (PK)
FREQUENCY RANGE	1GHz ~ 25GHz		Average (AV)

ANTENNA POLARITY & TEST DISTANCE: HORIZONTAL AT 3 M

NO.	FREQ. (MHz)	EMISSION LEVEL (dBuV/m)	LIMIT (dBuV/m)	MARGIN (dB)	ANTENNA HEIGHT (m)	TABLE ANGLE (Degree)	RAW VALUE (dBuV)	CORRECTION FACTOR (dB/m)
1	2390.00	55.7 PK	74.0	-18.3	1.56 H	172	57.58	-1.88
2	2390.00	43.2 AV	54.0	-10.8	1.56 H	172	45.08	-1.88
3	*2437.00	109.0 PK			1.69 H	170	110.81	-1.81
4	*2437.00	98.7 AV			1.69 H	170	100.51	-1.81
5	2483.50	66.5 PK	74.0	-7.5	1.56 H	172	68.29	-1.79
6	2483.50	49.7 AV	54.0	-4.3	1.56 H	172	51.49	-1.79
7	4874.00	53.4 PK	74.0	-20.6	1.71 H	136	46.57	6.83
8	4874.00	40.5 AV	54.0	-13.5	1.71 H	136	33.67	6.83
9	7311.00	56.4 PK	74.0	-17.6	1.60 H	111	45.26	11.14
10	7311.00	43.6 AV	54.0	-10.4	1.60 H	111	32.46	11.14

ANTENNA POLARITY & TEST DISTANCE: VERTICAL AT 3 M

NO.	FREQ. (MHz)	EMISSION LEVEL (dBuV/m)	LIMIT (dBuV/m)	MARGIN (dB)	ANTENNA HEIGHT (m)	TABLE ANGLE (Degree)	RAW VALUE (dBuV)	CORRECTION FACTOR (dB/m)
1	2390.00	55.5 PK	74.0	-18.5	1.77 V	88	57.38	-1.88
2	2390.00	43.0 AV	54.0	-11.0	1.77 V	88	44.88	-1.88
3	*2437.00	106.5 PK			1.88 V	89	108.31	-1.81
4	*2437.00	97.2 AV			1.88 V	89	99.01	-1.81
5	2483.50	64.4 PK	74.0	-9.6	1.77 V	88	66.19	-1.79
6	2483.50	47.6 AV	54.0	-6.4	1.77 V	88	49.39	-1.79
7	4874.00	53.0 PK	74.0	-21.0	1.35 V	188	46.17	6.83
8	4874.00	40.2 AV	54.0	-13.8	1.35 V	188	33.37	6.83
9	7311.00	57.1 PK	74.0	-16.9	1.34 V	182	45.96	11.14
10	7311.00	43.4 AV	54.0	-10.6	1.34 V	182	32.26	11.14

REMARKS:

1. Emission Level(dBuV/m) = Raw Value(dBuV) + Correction Factor(dB/m)
2. Correction Factor(dB/m) = Antenna Factor(dB/m) + Cable Factor(dB) – Pre-Amplifier Factor(dB)
3. The other emission levels were very low against the limit.
4. Margin value = Emission Level – Limit value
5. " * ": Fundamental frequency.



CHANNEL	TX Channel 11	DETECTOR FUNCTION	Peak (PK)
FREQUENCY RANGE	1GHz ~ 25GHz		Average (AV)

ANTENNA POLARITY & TEST DISTANCE: HORIZONTAL AT 3 M

NO.	FREQ. (MHz)	EMISSION LEVEL (dBuV/m)	LIMIT (dBuV/m)	MARGIN (dB)	ANTENNA HEIGHT (m)	TABLE ANGLE (Degree)	RAW VALUE (dBuV)	CORRECTION FACTOR (dB/m)
1	*2462.00	108.8 PK			1.70 H	164	110.60	-1.80
2	*2462.00	98.6 AV			1.70 H	164	100.40	-1.80
3	2483.50	69.5 PK	74.0	-4.5	1.67 H	157	71.29	-1.79
4	2483.50	53.8 AV	54.0	-0.2	1.67 H	157	55.59	-1.79
5	4924.00	53.3 PK	74.0	-20.7	1.65 H	126	46.39	6.91
6	4924.00	40.4 AV	54.0	-13.6	1.65 H	126	33.49	6.91
7	7386.00	56.8 PK	74.0	-17.2	1.65 H	127	45.23	11.57
8	7386.00	43.7 AV	54.0	-10.3	1.65 H	127	32.13	11.57

ANTENNA POLARITY & TEST DISTANCE: VERTICAL AT 3 M

NO.	FREQ. (MHz)	EMISSION LEVEL (dBuV/m)	LIMIT (dBuV/m)	MARGIN (dB)	ANTENNA HEIGHT (m)	TABLE ANGLE (Degree)	RAW VALUE (dBuV)	CORRECTION FACTOR (dB/m)
1	*2462.00	106.2 PK			1.84 V	84	108.00	-1.80
2	*2462.00	96.8 AV			1.84 V	84	98.60	-1.80
3	2483.50	67.3 PK	74.0	-6.7	1.84 V	84	69.09	-1.79
4	2483.50	51.6 AV	54.0	-2.4	1.84 V	84	53.39	-1.79
5	4924.00	52.8 PK	74.0	-21.2	1.34 V	184	45.89	6.91
6	4924.00	39.8 AV	54.0	-14.2	1.34 V	184	32.89	6.91
7	7386.00	57.3 PK	74.0	-16.7	1.34 V	184	45.73	11.57
8	7386.00	43.4 AV	54.0	-10.6	1.34 V	184	31.83	11.57

REMARKS:

1. Emission Level(dBuV/m) = Raw Value(dBuV) + Correction Factor(dB/m)
2. Correction Factor(dB/m) = Antenna Factor(dB/m) + Cable Factor(dB) – Pre-Amplifier Factor(dB)
3. The other emission levels were very low against the limit.
4. Margin value = Emission Level – Limit value
5. " * ": Fundamental frequency.

802.11n (HT20)

CHANNEL	TX Channel 1	DETECTOR FUNCTION	Peak (PK)
FREQUENCY RANGE	1GHz ~ 25GHz		Average (AV)

ANTENNA POLARITY & TEST DISTANCE: HORIZONTAL AT 3 M								
NO.	FREQ. (MHz)	EMISSION LEVEL (dBuV/m)	LIMIT (dBuV/m)	MARGIN (dB)	ANTENNA HEIGHT (m)	TABLE ANGLE (Degree)	RAW VALUE (dBuV)	CORRECTION FACTOR (dB/m)
1	2390.00	66.8 PK	74.0	-7.2	1.70 H	163	68.68	-1.88
2	2390.00	50.6 AV	54.0	-3.4	1.70 H	163	52.48	-1.88
3	*2412.00	107.4 PK			1.70 H	163	109.23	-1.83
4	*2412.00	97.1 AV			1.70 H	163	98.93	-1.83
5	4824.00	53.8 PK	74.0	-20.2	1.67 H	126	47.13	6.67
6	4824.00	40.6 AV	54.0	-13.4	1.67 H	126	33.93	6.67

ANTENNA POLARITY & TEST DISTANCE: VERTICAL AT 3 M								
NO.	FREQ. (MHz)	EMISSION LEVEL (dBuV/m)	LIMIT (dBuV/m)	MARGIN (dB)	ANTENNA HEIGHT (m)	TABLE ANGLE (Degree)	RAW VALUE (dBuV)	CORRECTION FACTOR (dB/m)
1	2390.00	64.1 PK	74.0	-9.9	1.80 V	88	65.98	-1.88
2	2390.00	48.2 AV	54.0	-5.8	1.80 V	88	50.08	-1.88
3	*2412.00	105.6 PK			1.80 V	88	107.43	-1.83
4	*2412.00	95.4 AV			1.80 V	88	97.23	-1.83
5	4824.00	52.9 PK	74.0	-21.1	1.36 V	205	46.23	6.67
6	4824.00	39.4 AV	54.0	-14.6	1.36 V	205	32.73	6.67

REMARKS:

1. Emission Level(dBuV/m) = Raw Value(dBuV) + Correction Factor(dB/m)
2. Correction Factor(dB/m) = Antenna Factor(dB/m) + Cable Factor(dB) – Pre-Amplifier Factor(dB)
3. The other emission levels were very low against the limit.
4. Margin value = Emission Level – Limit value
5. " * ": Fundamental frequency.

CHANNEL	TX Channel 6	DETECTOR FUNCTION	Peak (PK)
FREQUENCY RANGE	1GHz ~ 25GHz		Average (AV)

ANTENNA POLARITY & TEST DISTANCE: HORIZONTAL AT 3 M

NO.	FREQ. (MHz)	EMISSION LEVEL (dBuV/m)	LIMIT (dBuV/m)	MARGIN (dB)	ANTENNA HEIGHT (m)	TABLE ANGLE (Degree)	RAW VALUE (dBuV)	CORRECTION FACTOR (dB/m)
1	2390.00	56.1 PK	74.0	-17.9	1.57 H	170	57.98	-1.88
2	2390.00	43.5 AV	54.0	-10.5	1.57 H	170	45.38	-1.88
3	*2437.00	107.0 PK			1.57 H	170	108.81	-1.81
4	*2437.00	96.6 AV			1.57 H	170	98.41	-1.81
5	2483.50	66.8 PK	74.0	-7.2	1.57 H	170	68.59	-1.79
6	2483.50	48.8 AV	54.0	-5.2	1.57 H	170	50.59	-1.79
7	4874.00	53.4 PK	74.0	-20.6	1.59 H	118	46.57	6.83
8	4874.00	40.5 AV	54.0	-13.5	1.59 H	118	33.67	6.83
9	7311.00	57.4 PK	74.0	-16.6	1.72 H	125	46.26	11.14
10	7311.00	44.1 AV	54.0	-9.9	1.72 H	125	32.96	11.14

ANTENNA POLARITY & TEST DISTANCE: VERTICAL AT 3 M

NO.	FREQ. (MHz)	EMISSION LEVEL (dBuV/m)	LIMIT (dBuV/m)	MARGIN (dB)	ANTENNA HEIGHT (m)	TABLE ANGLE (Degree)	RAW VALUE (dBuV)	CORRECTION FACTOR (dB/m)
1	2390.00	55.7 PK	74.0	-18.3	1.75 V	74	57.58	-1.88
2	2390.00	43.3 AV	54.0	-10.7	1.75 V	74	45.18	-1.88
3	*2437.00	105.1 PK			1.85 V	94	106.91	-1.81
4	*2437.00	94.9 AV			1.85 V	94	96.71	-1.81
5	2483.50	64.9 PK	74.0	-9.1	1.73 V	78	66.69	-1.79
6	2483.50	47.3 AV	54.0	-6.7	1.73 V	78	49.09	-1.79
7	4874.00	53.5 PK	74.0	-20.5	1.37 V	198	46.67	6.83
8	4874.00	40.0 AV	54.0	-14.0	1.37 V	198	33.17	6.83
9	7311.00	57.5 PK	74.0	-16.5	1.38 V	190	46.36	11.14
10	7311.00	43.5 AV	54.0	-10.5	1.38 V	190	32.36	11.14

REMARKS:

1. Emission Level(dBuV/m) = Raw Value(dBuV) + Correction Factor(dB/m)
2. Correction Factor(dB/m) = Antenna Factor(dB/m) + Cable Factor(dB) – Pre-Amplifier Factor(dB)
3. The other emission levels were very low against the limit.
4. Margin value = Emission Level – Limit value
5. " * ": Fundamental frequency.



A D T

CHANNEL	TX Channel 11	DETECTOR FUNCTION	Peak (PK)
FREQUENCY RANGE	1GHz ~ 25GHz		Average (AV)

ANTENNA POLARITY & TEST DISTANCE: HORIZONTAL AT 3 M

NO.	FREQ. (MHz)	EMISSION LEVEL (dBuV/m)	LIMIT (dBuV/m)	MARGIN (dB)	ANTENNA HEIGHT (m)	TABLE ANGLE (Degree)	RAW VALUE (dBuV)	CORRECTION FACTOR (dB/m)
1	*2462.00	106.8 PK			1.60 H	154	108.60	-1.80
2	*2462.00	96.2 AV			1.60 H	154	98.00	-1.80
3	2483.50	70.6 PK	74.0	-3.4	1.67 H	153	72.39	-1.79
4	2483.50	53.5 AV	54.0	-0.5	1.67 H	153	55.29	-1.79
5	4924.00	53.9 PK	74.0	-20.1	1.63 H	116	46.99	6.91
6	4924.00	40.7 AV	54.0	-13.3	1.63 H	116	33.79	6.91
7	7386.00	57.1 PK	74.0	-16.9	1.70 H	118	45.53	11.57
8	7386.00	43.9 AV	54.0	-10.1	1.70 H	118	32.33	11.57

ANTENNA POLARITY & TEST DISTANCE: VERTICAL AT 3 M

NO.	FREQ. (MHz)	EMISSION LEVEL (dBuV/m)	LIMIT (dBuV/m)	MARGIN (dB)	ANTENNA HEIGHT (m)	TABLE ANGLE (Degree)	RAW VALUE (dBuV)	CORRECTION FACTOR (dB/m)
1	*2462.00	104.9 PK			1.89 V	104	106.70	-1.80
2	*2462.00	94.6 AV			1.89 V	104	96.40	-1.80
3	2483.50	68.1 PK	74.0	-5.9	1.89 V	104	69.89	-1.79
4	2483.50	51.3 AV	54.0	-2.7	1.89 V	104	53.09	-1.79
5	4924.00	53.0 PK	74.0	-21.0	1.37 V	197	46.09	6.91
6	4924.00	39.7 AV	54.0	-14.3	1.37 V	197	32.79	6.91
7	7386.00	57.6 PK	74.0	-16.4	1.35 V	185	46.03	11.57
8	7386.00	43.5 AV	54.0	-10.5	1.35 V	185	31.93	11.57

REMARKS:

1. Emission Level(dBuV/m) = Raw Value(dBuV) + Correction Factor(dB/m)
2. Correction Factor(dB/m) = Antenna Factor(dB/m) + Cable Factor(dB) – Pre-Amplifier Factor(dB)
3. The other emission levels were very low against the limit.
4. Margin value = Emission Level – Limit value

Below 1GHz Data

802.11g

CHANNEL	TX Channel 1	DETECTOR FUNCTION	Quasi-Peak (QP)
FREQUENCY RANGE	Below 1GHz		

ANTENNA POLARITY & TEST DISTANCE: HORIZONTAL AT 3 M

NO.	FREQ. (MHz)	EMISSION LEVEL (dBuV/m)	LIMIT (dBuV/m)	MARGIN (dB)	ANTENNA HEIGHT (m)	TABLE ANGLE (Degree)	RAW VALUE (dBuV)	CORRECTION FACTOR (dB/m)
1	79.25	19.2 QP	40.0	-20.8	2.50 H	1	31.80	-12.58
2	136.22	19.8 QP	43.5	-23.7	1.50 H	306	28.51	-8.73
3	314.99	21.3 QP	46.0	-24.7	2.50 H	147	27.39	-6.06
4	458.18	23.9 QP	46.0	-22.2	2.50 H	216	26.27	-2.42
5	656.91	26.3 QP	46.0	-19.7	2.00 H	326	24.75	1.59
6	897.88	31.5 QP	46.0	-14.5	2.00 H	299	25.77	5.72

ANTENNA POLARITY & TEST DISTANCE: VERTICAL AT 3 M

NO.	FREQ. (MHz)	EMISSION LEVEL (dBuV/m)	LIMIT (dBuV/m)	MARGIN (dB)	ANTENNA HEIGHT (m)	TABLE ANGLE (Degree)	RAW VALUE (dBuV)	CORRECTION FACTOR (dB/m)
1	30.80	27.7 QP	40.0	-12.3	1.00 V	281	37.07	-9.36
2	40.52	24.9 QP	40.0	-15.1	1.00 V	271	33.82	-8.89
3	79.03	24.1 QP	40.0	-15.9	2.50 V	360	36.62	-12.55
4	128.75	29.0 QP	43.5	-14.5	2.50 V	360	38.25	-9.25
5	537.70	24.6 QP	46.0	-21.5	2.50 V	360	25.56	-1.01
6	852.71	29.6 QP	46.0	-16.4	1.00 V	156	24.55	5.01

REMARKS:

1. Emission Level(dBuV/m) = Raw Value(dBuV) + Correction Factor(dB/m)
2. Correction Factor(dB/m) = Antenna Factor(dB/m) + Cable Factor(dB) – Pre-Amplifier Factor(dB)
3. The other emission levels were very low against the limit.
4. Margin value = Emission Level – Limit value

4.2 Conducted Emission Measurement

4.2.1 Limits of Conducted Emission Measurement

Frequency (MHz)	Conducted Limit (dBuV)	
	Quasi-peak	Average
0.15 - 0.5	66 - 56	56 - 46
0.50 - 5.0	56	46
5.0 - 30.0	60	50

Note: 1. The lower limit shall apply at the transition frequencies.

2. The limit decreases in line with the logarithm of the frequency in the range of 0.15 to 0.50MHz.

4.2.2 Test Instruments

DESCRIPTION & MANUFACTURER	MODEL NO.	SERIAL NO.	CALIBRATED DATE	CALIBRATED UNTIL
Test Receiver R&S	ESCS 30	847124/029	Oct 23, 2015	Oct. 22, 2016
Line-Impedance Stabilization Network (for EUT) SCHWARZBECK	NSLK-8127	8127-522	Sep. 01, 2015	Aug. 31, 2016
Line-Impedance Stabilization Network (for Peripheral) R&S	ENV216	100072	June 11, 2015	June 10, 2016
RF Cable	5D-FB	COCCAB-001	Mar. 08, 2016	Mar. 07, 2017
10 dB PAD Mini-Circuits	HAT-10+	CONATT-002	Sep. 14, 2015	Sep. 13, 2016
50 ohms Terminator	N/A	EMC-03	Sep. 23, 2015	Sep. 22, 2016
50 ohms Terminator	N/A	EMC-02	Oct. 01, 2015	Sep. 30, 2016
50 ohms Terminator	E1-011315	13	Dec. 11 2015	Dec. 10 2016
Software BVADT	BVADT_Cond_ V7.3.7.3	NA	NA	NA

Note:

1. The calibration interval of the above test instruments are 12 months and the calibrations are traceable to NML/ROC and NIST/USA.
2. The test was performed in Shielded Room No. C.
3. The VCCI Con C Registration No. is C-3611.
4. Tested Date: Apr. 18 to June 07, 2016

4.2.3 Test Procedures

- a. The EUT was placed 0.4 meters from the conducting wall of the shielded room with EUT being connected to the power mains through a line impedance stabilization network (LISN). Other support units were connected to the power mains through another LISN. The two LISNs provide 50 ohm/ 50uH of coupling impedance for the measuring instrument.
- b. Both lines of the power mains connected to the EUT were checked for maximum conducted interference.
- c. The frequency range from 150kHz to 30MHz was searched. Emission levels under (Limit - 20dB) was not recorded.

NOTE: The resolution bandwidth and video bandwidth of test receiver is 9kHz for quasi-peak detection (QP) and average detection (AV) at frequency 0.15MHz-30MHz.

4.2.4 Deviation from Test Standard

No deviation.

4.2.5 Test Setup

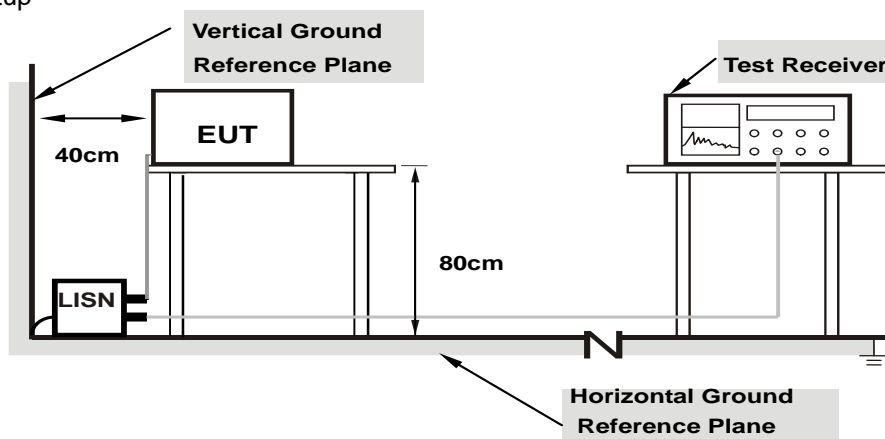

Note: 1.Support units were connected to second LISN.

For the actual test configuration, please refer to the attached file (Test Setup Photo).

4.2.6 EUT Operating Conditions

Same as 4.1.6.

4.2.7 Test Results (Mode 1)

Phase	Line (L)	Detector Function	Quasi-Peak (QP) / Average (AV)
-------	----------	-------------------	--------------------------------

No	Freq. [MHz]	Corr. Factor	Reading Value [dB (uV)]		Emission Level [dB (uV)]		Limit [dB (uV)]		Margin (dB)	
		(dB)	Q.P.	AV.	Q.P.	AV.	Q.P.	AV.	Q.P.	AV.
	1	0.32578	10.42	24.11	11.12	34.53	21.54	59.56	49.56	-25.03
2	0.34531	10.42	24.38	13.59	34.80	24.01	59.07	49.07	-24.27	-25.06
3	0.54844	10.42	12.20	-0.05	22.62	10.37	56.00	46.00	-33.38	-35.63
4	0.68125	10.41	10.98	-0.39	21.39	10.02	56.00	46.00	-34.61	-35.98
5	4.04297	10.63	13.79	-3.60	24.42	7.03	56.00	46.00	-31.58	-38.97
6	7.57813	10.80	8.82	0.26	19.62	11.06	60.00	50.00	-40.38	-38.94

REMARKS:

1. Q.P. and AV. are abbreviations of quasi-peak and average individually.
2. The emission levels of other frequencies were very low against the limit.
3. Margin value = Emission level - Limit value
4. Correction factor = Insertion loss + Cable loss
5. Emission Level = Correction Factor + Reading Value.

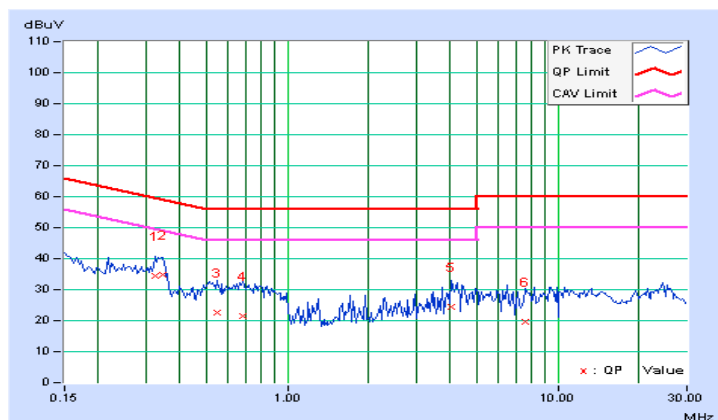

Phase	Neutral (N)	Detector Function	Quasi-Peak (QP) / Average (AV)
-------	-------------	-------------------	--------------------------------

No	Freq. [MHz]	Corr.	Reading Value		Emission Level		Limit		Margin	
		Factor	[dB (uV)]		[dB (uV)]		[dB (uV)]		(dB)	
	(dB)	Q.P.	AV.	Q.P.	AV.	Q.P.	AV.	Q.P.	AV.	
1	0.16562	10.45	21.12	5.72	31.57	16.17	65.18	55.18	-33.61	-39.01
2	0.33359	10.47	18.97	5.61	29.44	16.08	59.36	49.36	-29.92	-33.28
3	0.70859	10.45	9.53	-3.14	19.98	7.31	56.00	46.00	-36.02	-38.69
4	3.29688	10.65	9.77	-2.08	20.42	8.57	56.00	46.00	-35.58	-37.43
5	4.01563	10.73	12.24	-4.91	22.97	5.82	56.00	46.00	-33.03	-40.18
6	10.57422	10.98	12.05	-1.87	23.03	9.11	60.00	50.00	-36.97	-40.89

REMARKS:

1. Q.P. and AV. are abbreviations of quasi-peak and average individually.
2. The emission levels of other frequencies were very low against the limit.
3. Margin value = Emission level - Limit value
4. Correction factor = Insertion loss + Cable loss
5. Emission Level = Correction Factor + Reading Value.

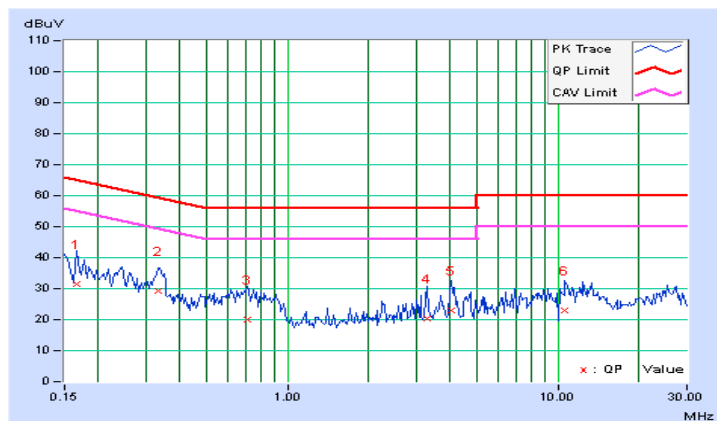

4.2.8 Test Results (Mode 2)

Phase	Line (L)	Detector Function	Quasi-Peak (QP) / Average (AV)
-------	----------	-------------------	--------------------------------

No	Freq. [MHz]	Corr.	Reading Value		Emission Level		Limit		Margin	
		Factor	[dB (uV)]		[dB (uV)]		[dB (uV)]		(dB)	
	(dB)	Q.P.	AV.	Q.P.	AV.	Q.P.	AV.	Q.P.	AV.	
1	0.54063	10.28	28.60	11.83	38.88	22.11	56.00	46.00	-17.12	-23.89
2	0.63438	10.27	27.99	13.84	38.26	24.11	56.00	46.00	-17.74	-21.89
3	0.90781	10.24	21.18	9.60	31.42	19.84	56.00	46.00	-24.58	-26.16
4	3.42188	10.38	21.78	16.04	32.16	26.42	56.00	46.00	-23.84	-19.58
5	6.41797	10.47	19.12	12.92	29.59	23.39	60.00	50.00	-30.41	-26.61
6	16.72656	10.85	26.23	18.28	37.08	29.13	60.00	50.00	-22.92	-20.87

REMARKS:

1. Q.P. and AV. are abbreviations of quasi-peak and average individually.
2. The emission levels of other frequencies were very low against the limit.
3. Margin value = Emission level - Limit value
4. Correction factor = Insertion loss + Cable loss
5. Emission Level = Correction Factor + Reading Value.

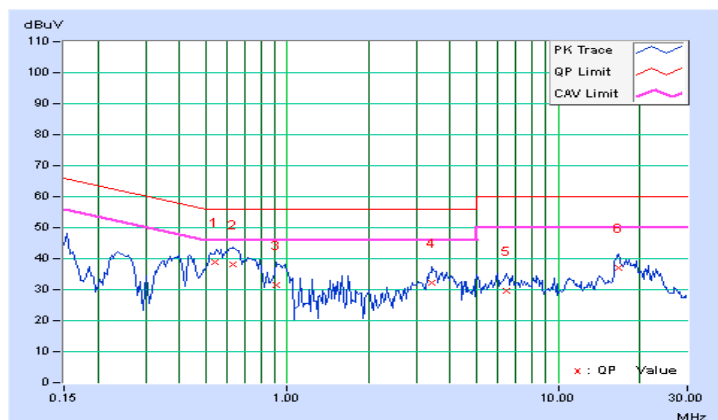

Phase	Neutral (N)	Detector Function	Quasi-Peak (QP) / Average (AV)
-------	-------------	-------------------	--------------------------------

No	Freq. [MHz]	Corr.	Reading Value		Emission Level		Limit		Margin	
		Factor (dB)	[dB (uV)]		[dB (uV)]		[dB (uV)]		(dB)	
	Q.P.	AV.	Q.P.	AV.	Q.P.	AV.	Q.P.	AV.	Q.P.	AV.
1	0.44688	10.28	26.89	11.70	37.17	21.98	56.93	46.93	-19.76	-24.95
2	0.66953	10.25	29.05	16.01	39.30	26.26	56.00	46.00	-16.70	-19.74
3	0.79063	10.24	22.43	8.87	32.67	19.11	56.00	46.00	-23.33	-26.89
4	3.57031	10.40	23.56	17.41	33.96	27.81	56.00	46.00	-22.04	-18.19
5	5.56641	10.47	17.28	12.85	27.75	23.32	60.00	50.00	-32.25	-26.68
6	16.33203	10.86	24.72	19.62	35.58	30.48	60.00	50.00	-24.42	-19.52

REMARKS:

1. Q.P. and AV. are abbreviations of quasi-peak and average individually.
2. The emission levels of other frequencies were very low against the limit.
3. Margin value = Emission level - Limit value
4. Correction factor = Insertion loss + Cable loss
5. Emission Level = Correction Factor + Reading Value.

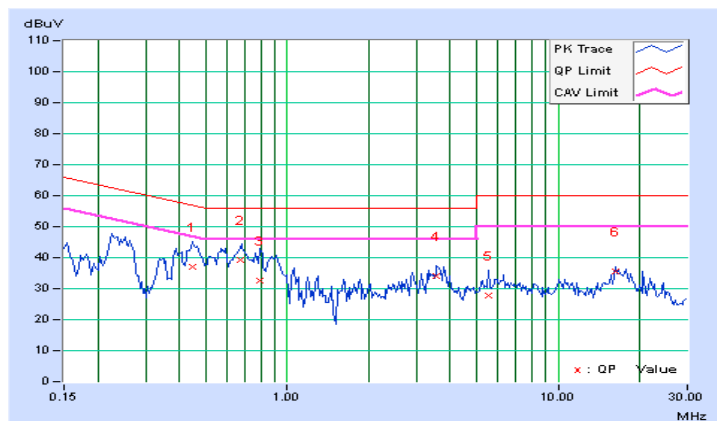

4.3 6dB Bandwidth Measurement

4.3.1 Limits of 6dB Bandwidth Measurement

The minimum of 6dB Bandwidth Measurement is 0.5 MHz.

4.3.2 Test Setup

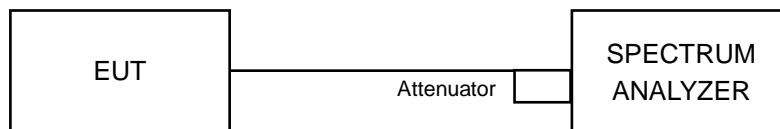

4.3.3 Test Instruments

Refer to section 4.1.2 to get information of above instrument.

4.3.4 Test Procedure

- a. Set resolution bandwidth (RBW) = 100kHz
- b. Set the video bandwidth (VBW) $\geq 3 \times$ RBW, Detector = Peak.
- c. Trace mode = max hold.
- d. Sweep = auto couple.
- e. Measure the maximum width of the emission that is constrained by the frequencies associated with the two amplitude points (upper and lower) that are attenuated by 6 dB relative to the maximum level measured in the fundamental emission

4.3.5 Deviation from Test Standard

No deviation.

4.3.6 EUT Operating Conditions

The software provided by client to enable the EUT under transmission condition continuously at lowest, middle and highest channel frequencies individually.



4.3.7 Test Result

802.11b

Channel	Frequency (MHz)	6dB Bandwidth (MHz)	Minimum Limit (MHz)	Pass / Fail
1	2412	9.04	0.5	PASS
6	2437	9.08	0.5	PASS
11	2462	9.07	0.5	PASS

802.11g

Channel	Frequency (MHz)	6dB Bandwidth (MHz)	Minimum Limit (MHz)	Pass / Fail
1	2412	16.61	0.5	PASS
6	2437	16.63	0.5	PASS
11	2462	16.60	0.5	PASS

802.11n (HT20)

Channel	Frequency (MHz)	6dB Bandwidth (MHz)	Minimum Limit (MHz)	Pass / Fail
1	2412	17.83	0.5	Pass
6	2437	17.79	0.5	Pass
11	2462	17.80	0.5	Pass

Spectrum Plot of Worst Value

802.11b / CH1

802.11g / CH11

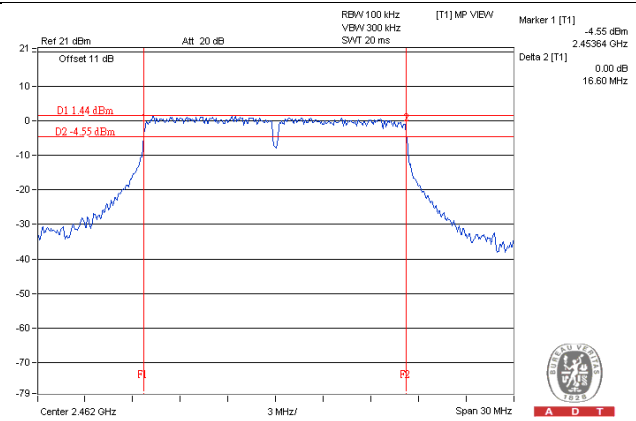
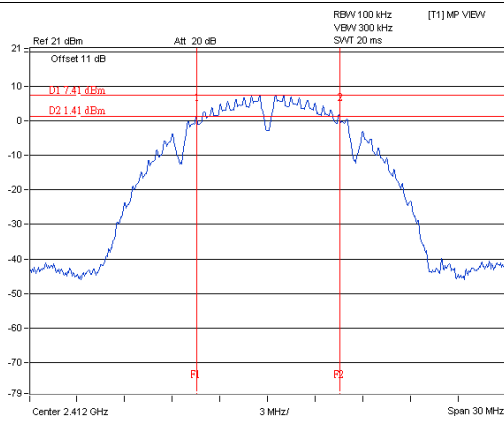

802.11n (HT20) / CH6

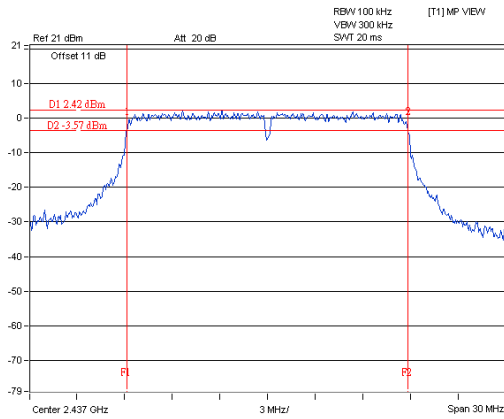

4.4 Conducted Output Power Measurement

4.4.1 Limits of Conducted Output Power Measurement

For systems using digital modulation in the 2400–2483.5 MHz bands: 1 Watt (30dBm)

4.4.2 Test Setup

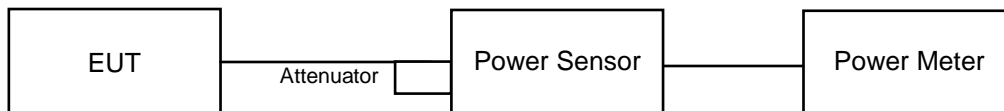

4.4.3 Test Instruments

Refer to section 4.1.2 to get information of above instrument.

4.4.4 Test Procedures

A peak / average power sensor was used on the output port of the EUT. A power meter was used to read the response of the peak / average power sensor. Record the power level.

4.4.5 Deviation from Test Standard

No deviation.

4.4.6 EUT Operating Conditions

Same as Item 4.3.6.

4.4.7 Test Results

FOR PEAK POWER**802.11b**

Channel	Frequency (MHz)	Peak Power (mW)	Peak Power (dBm)	Limit (dBm)	Pass/Fail
1	2412	95.94	19.82	30	Pass
6	2437	95.06	19.78	30	Pass
11	2462	96.605	19.85	30	Pass

802.11g

Channel	Frequency (MHz)	Peak Power (mW)	Peak Power (dBm)	Limit (dBm)	Pass/Fail
1	2412	239.883	23.80	30	Pass
6	2437	239.332	23.79	30	Pass
11	2462	164.437	22.16	30	Pass

802.11n (HT20)

Channel	Frequency (MHz)	Peak Power (mW)	Peak Power (dBm)	Limit (dBm)	Pass/Fail
1	2412	234.423	23.70	30	Pass
6	2437	231.206	23.64	30	Pass
11	2462	154.17	21.88	30	Pass

FOR AVERAGE POWER**802.11b**

Channel	Frequency (MHz)	Average Power (mW)	Average Power (dBm)
1	2412	48.753	16.88
6	2437	48.195	16.83
11	2462	49.431	16.94

802.11g

Channel	Frequency (MHz)	Average Power (mW)	Average Power (dBm)
1	2412	46.989	16.72
6	2437	46.881	16.71
11	2462	38.107	15.81

802.11n (HT20)

Channel	Frequency (MHz)	Average Power (mW)	Average Power (dBm)
1	2412	44.978	16.53
6	2437	41.976	16.23
11	2462	37.411	15.73

4.5 Power Spectral Density Measurement

4.5.1 Limits of Power Spectral Density Measurement

The Maximum of Power Spectral Density Measurement is 8dBm.

4.5.2 Test Setup

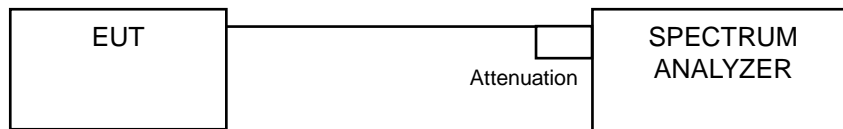

4.5.3 Test Instruments

Refer to section 4.1.2 to get information of above instrument.

4.5.4 Test Procedure

- a. Set analyzer center frequency to DTS channel center frequency.
- b. Set the span to 1.5 times the DTS bandwidth.
- c. Set the RBW to: $3 \text{ kHz} \leq \text{RBW} \leq 100 \text{ kHz}$.
- d. Set the VBW $\geq 3 \times \text{RBW}$.
- e. Detector = peak.
- f. Sweep time = auto couple.
- g. Trace mode = max hold.
- h. Allow trace to fully stabilize.
- i. Use the peak marker function to determine the maximum amplitude level within the RBW.

4.5.5 Deviation from Test Standard

No deviation.

4.5.6 EUT Operating Condition

Same as Item 4.3.6

4.5.7 Test Results

802.11b

Channel	Freq. (MHz)	PSD (dBm/3kHz)	Limit (dBm/3kHz)	Pass /Fail
1	2412	-12.68	8	Pass
6	2437	-12.50	8	Pass
11	2462	-13.22	8	Pass

802.11g

Channel	Freq. (MHz)	PSD (dBm/3kHz)	Limit (dBm/3kHz)	Pass /Fail
1	2412	-11.98	8	Pass
6	2437	-12.76	8	Pass
11	2462	-12.96	8	Pass

802.11n (HT20)

Channel	Freq. (MHz)	PSD (dBm/3kHz)	Limit (dBm/3kHz)	Pass /Fail
1	2412	-12.98	8	Pass
6	2437	-11.52	8	Pass
11	2462	-11.51	8	Pass

Spectrum Plot of Worst Value

802.11b / CH6

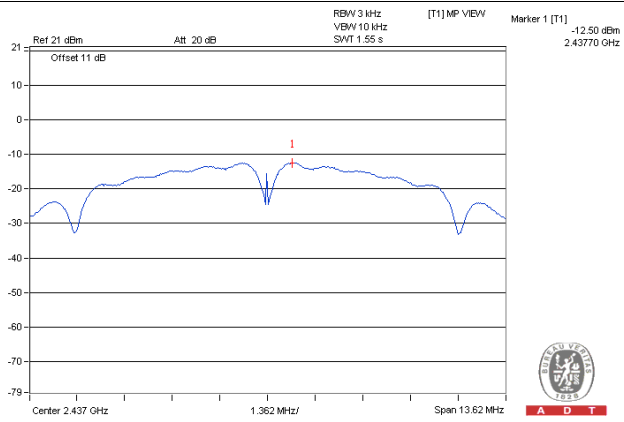

802.11g / CH1

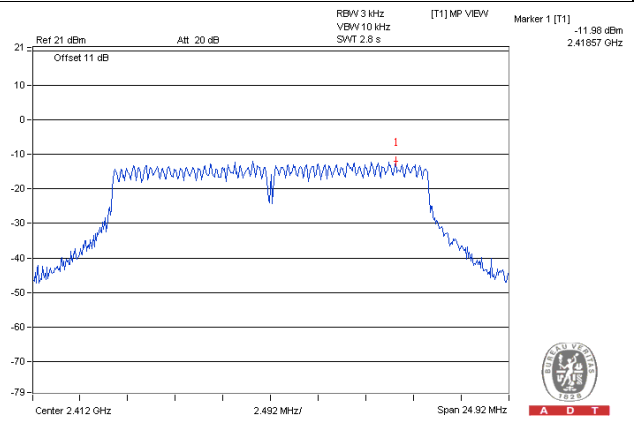

802.11n (HT20) / CH11

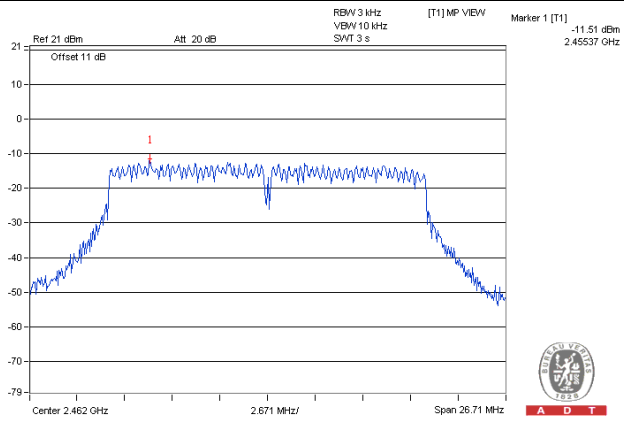

4.6 Conducted Out of Band Emission Measurement

4.6.1 Limits of Conducted Out of Band Emission Measurement

Below 20dB of the highest emission level of operating band (in 100kHz Resolution Bandwidth).

4.6.2 Test Setup

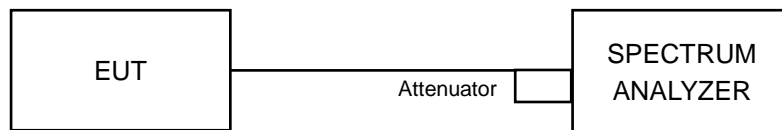

4.6.3 Test Instruments

Refer to section 4.1.2 to get information of above instrument.

4.6.4 Test Procedure

MEASUREMENT PROCEDURE REF

1. Set the RBW = 100 kHz.
2. Set the VBW \geq 300 kHz.
3. Detector = peak.
4. Sweep time = auto couple.
5. Trace mode = max hold.
6. Allow trace to fully stabilize.
7. Use the peak marker function to determine the maximum power level in any 100 kHz band segment within the fundamental EBW.

MEASUREMENT PROCEDURE OOB

1. Set RBW = 100 kHz.
2. Set VBW \geq 300 kHz.
3. Detector = peak.
4. Sweep = auto couple.
5. Trace Mode = max hold.
6. Allow trace to fully stabilize.
7. Use the peak marker function to determine the maximum amplitude level.

4.6.5 Deviation from Test Standard

No deviation.

4.6.6 EUT Operating Condition

Same as Item 4.3.6

4.6.7 Test Results

The spectrum plots are attached on the following pages. D1 line indicates the highest level, and D2 line indicates the 20dB offset below D1. It shows compliance with the requirement.

802.11b

CH 1

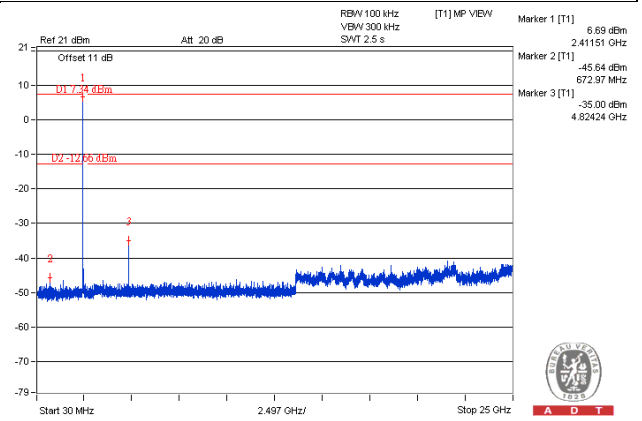
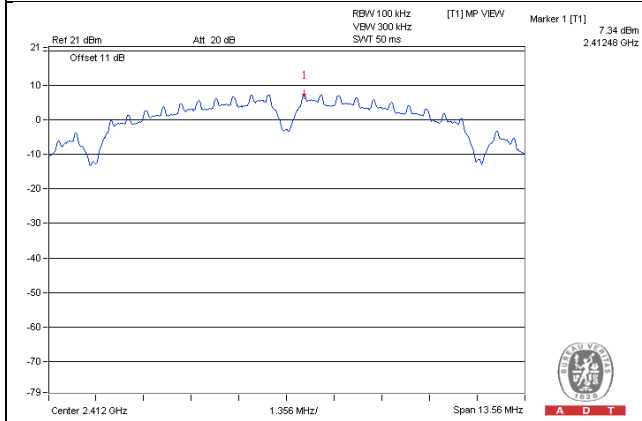

CH 6

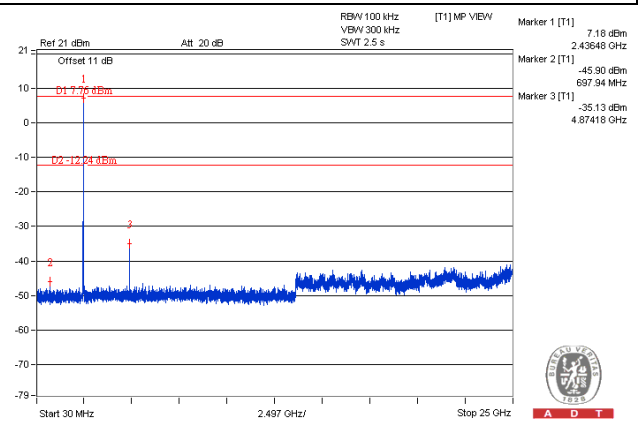
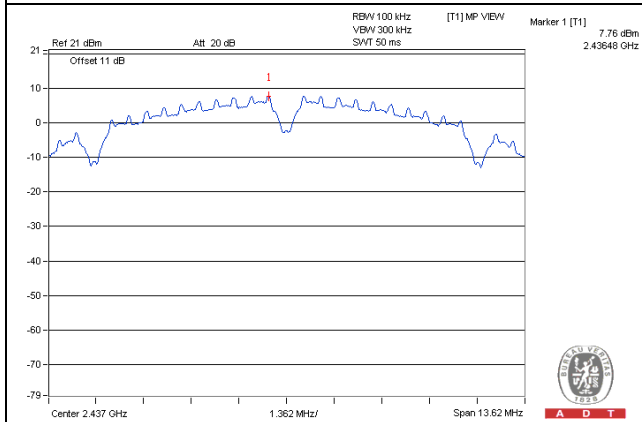

CH 11

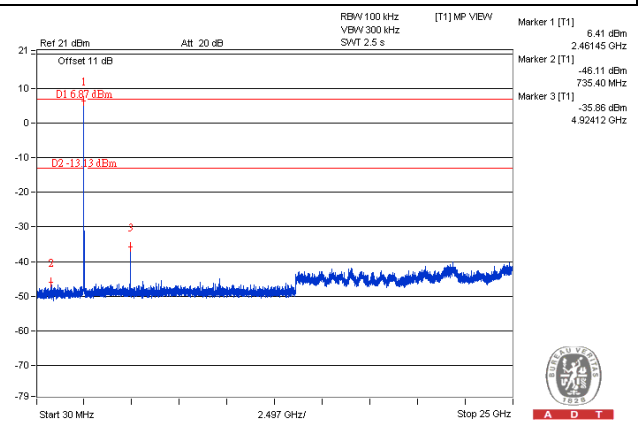
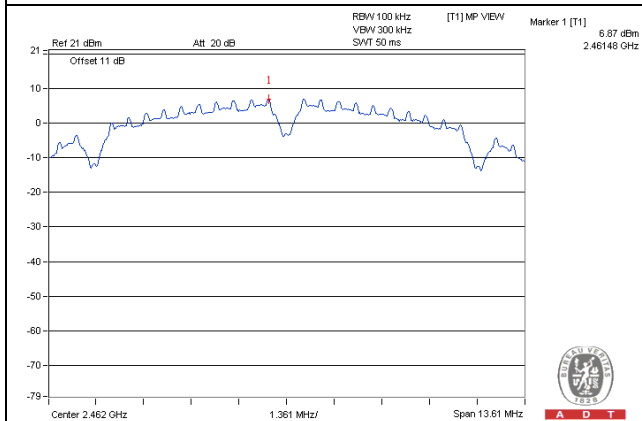

CH 1 Band edge

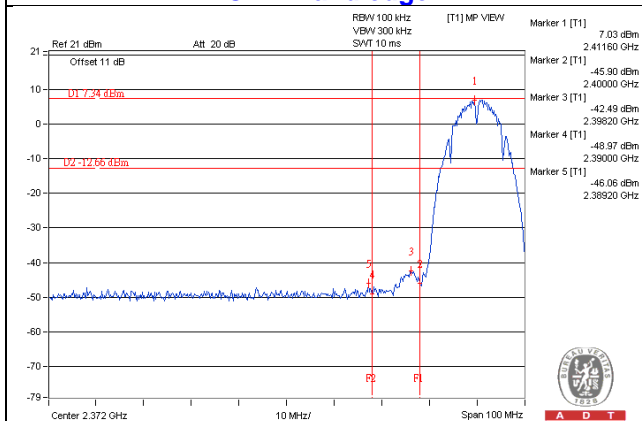

CH 11 Band edge

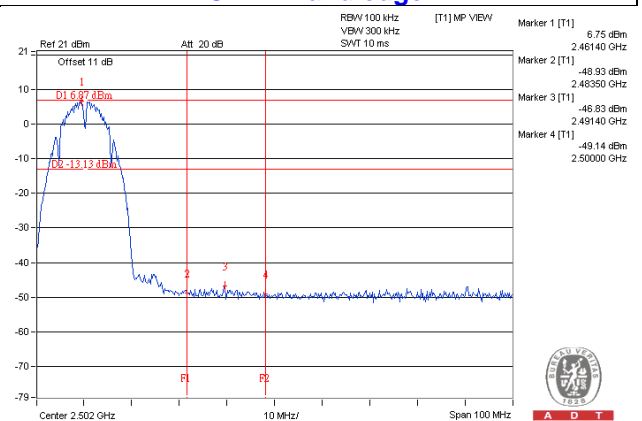

802.11g

CH 1

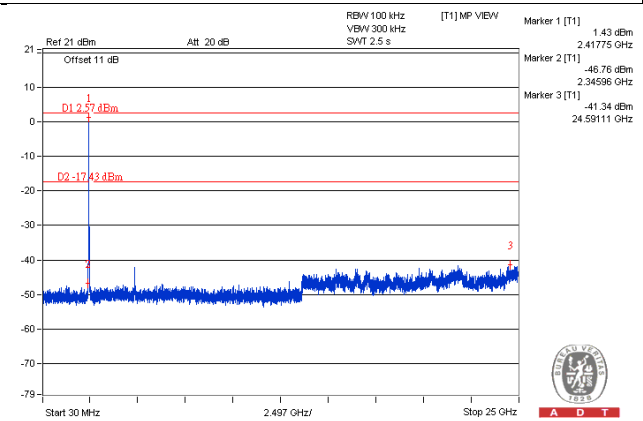
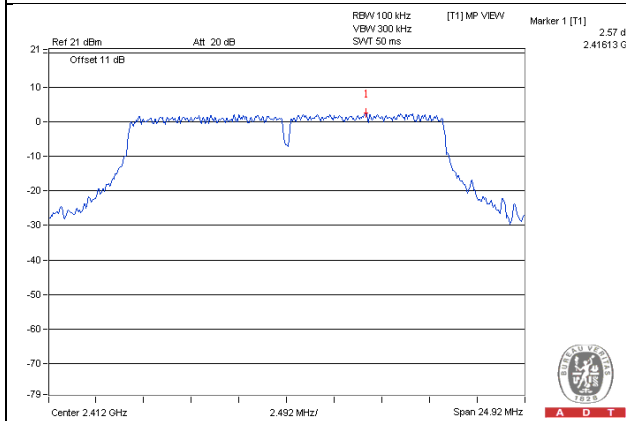

CH 6

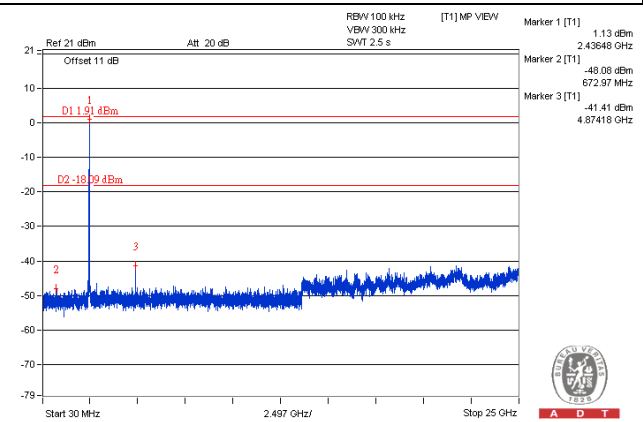
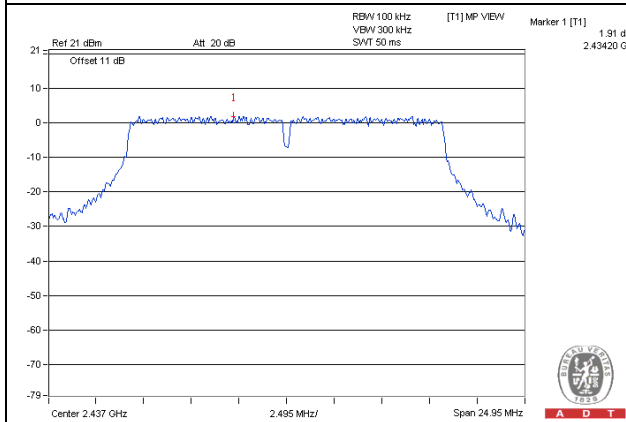

CH 11

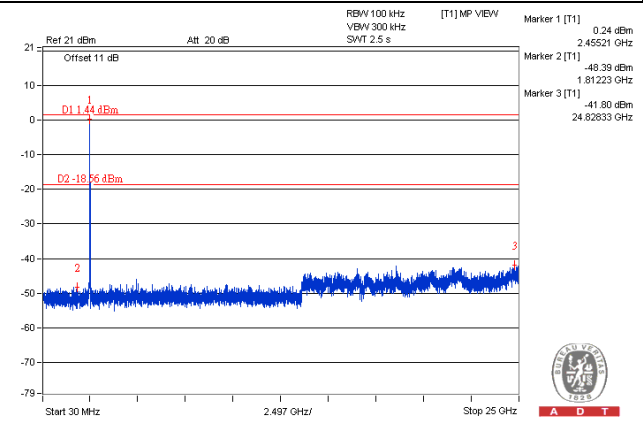
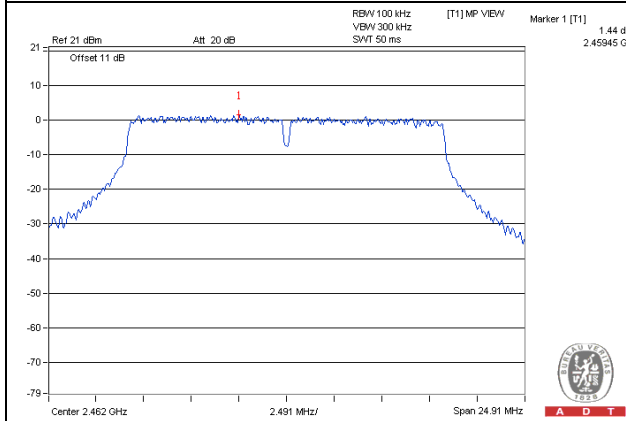

CH 1 Band edge

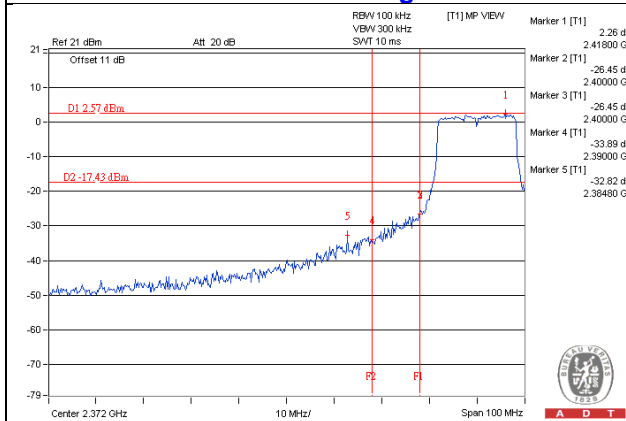

CH 11 Band edge

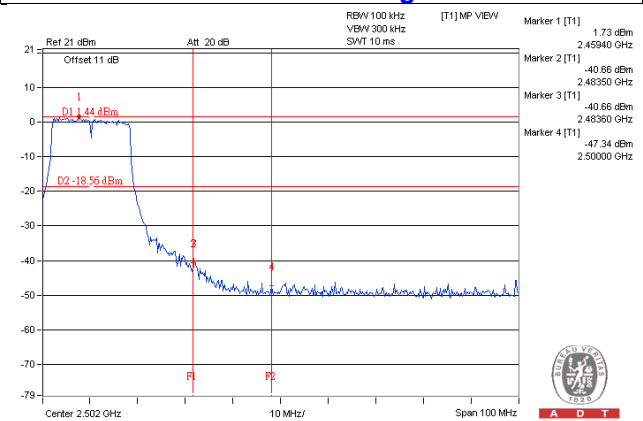

802.11n (HT20)

CH 1

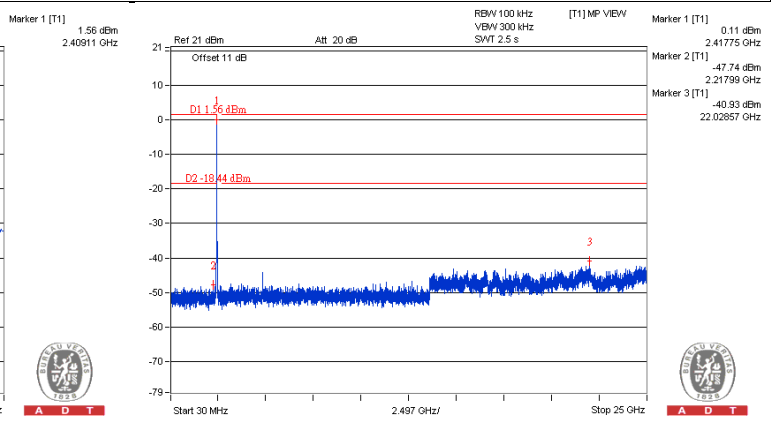
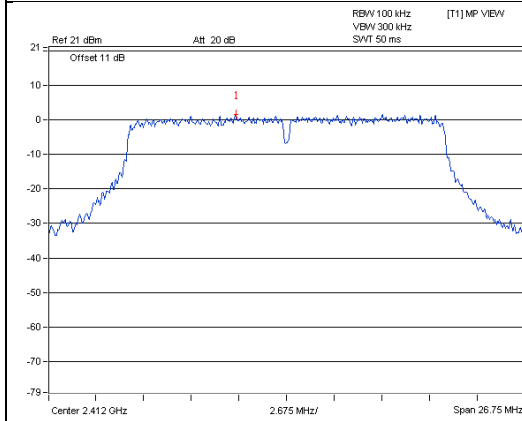

CH 6

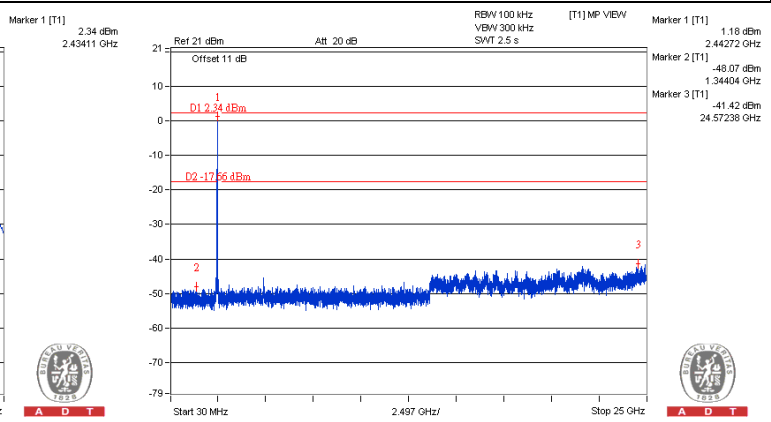
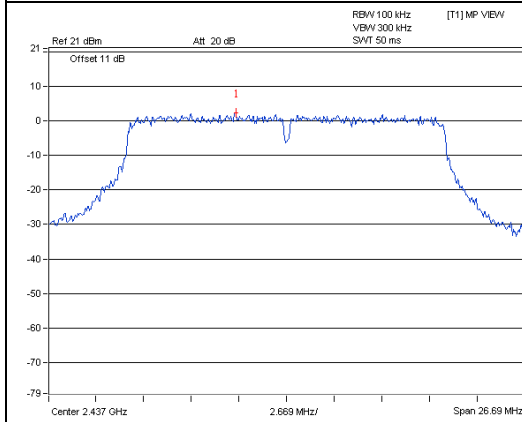

CH 11

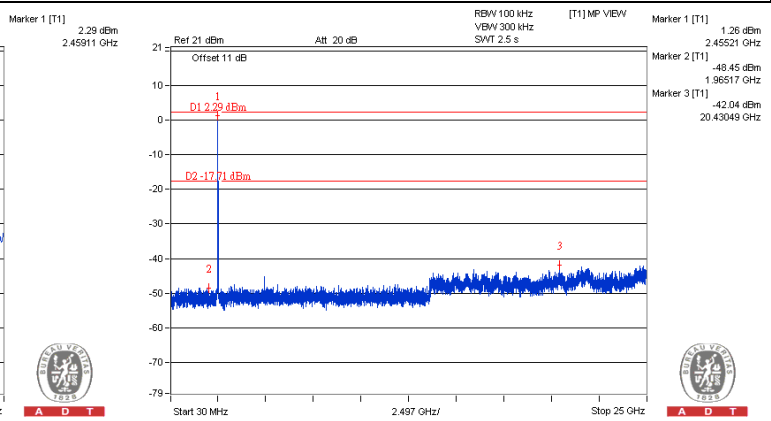
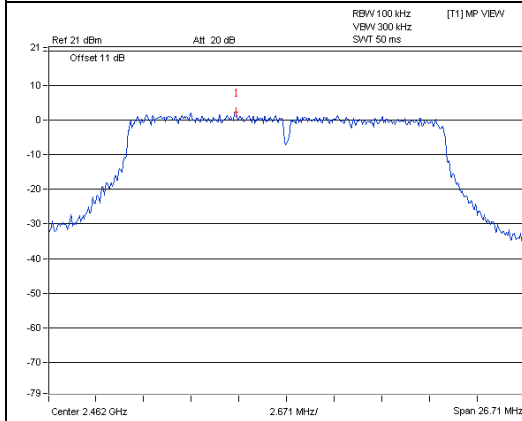

CH 1 Band edge

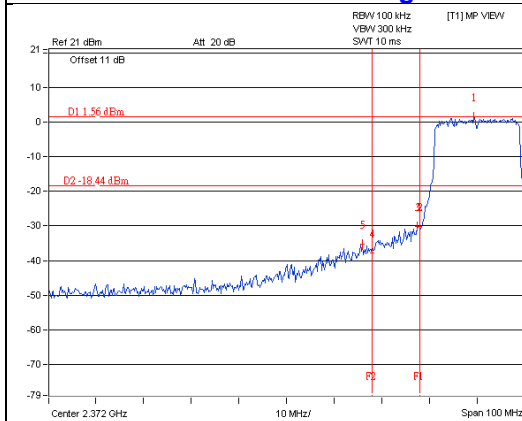

CH 11 Band edge

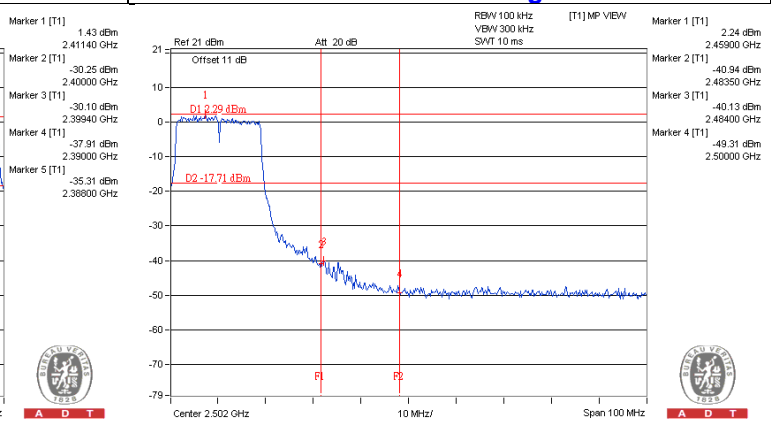



5 Pictures of Test Arrangements

Please refer to the attached file (Test Setup Photo).



Appendix – Information on the Testing Laboratories

We, Bureau Veritas Consumer Products Services (H.K.) Ltd., Taoyuan Branch, were founded in 1988 to provide our best service in EMC, Radio, Telecom and Safety consultation. Our laboratories are accredited and approved according to ISO/IEC 17025.

If you have any comments, please feel free to contact us at the following:

Linko EMC/RF Lab

Tel: 886-2-26052180

Fax: 886-2-26051924

Hsin Chu EMC/RF/Telecom Lab

Tel: 886-3-6668565

Fax: 886-3-6668323

Hwa Ya EMC/RF/Safety Lab

Tel: 886-3-3183232

Fax: 886-3-3270892

Email: service.adt@tw.bureauveritas.com

Web Site: www.bureauveritas-adt.com

The address and road map of all our labs can be found in our web site also.

--- END ---