

Project No: TM-2207000085P
 Report No.: TMWK2210004067KR

Page: 1 / 93
 Rev.: 00

RADIO TEST REPORT

FCC 47 CFR PART 15 SUBPART C

Test Standard	FCC Part 15.247
FCC ID	NOIKB-E70P24
Product name	7.8" Digital Note Pad; 7.8" Color Digital Note Pad; 7.8" Digital Reader; 7.8" Color Digital Reader
Brand Name	MobiScribe
Model No.	E70P24
Test Result	Pass
Statements of Conformity	Determination of compliance is based on the results of the compliance measurement, not taking into account measurement instrumentation uncertainty.

The test Result was tested by Compliance Certification Services Inc. The test data, data evaluation, test procedures, and equipment configurations shown in this report were given in ANSI C63.10: 2013 and compliance standards.

The test results of this report relate only to the tested sample (EUT) identified in this report.

The test Report of full or partial shall not copy. Without written approval of Compliance Certification Services Inc. (Wugu Laboratory)

Approved by:

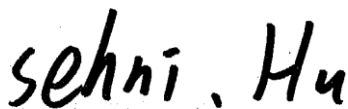

Sehni Hu
 Supervisor

Unless otherwise stated the results shown in this test report refer only to the sample(s) tested and such sample(s) are retained for 90 days only.
 除非另有說明，此報告結果僅對測試之樣品負責，同時此樣品僅保留90天。本報告未經本公司書面許可，不可部份複製。

This document is issued by the Company subject to its General Conditions of Service printed overleaf, available on request or accessible at <http://www.sgs.com.tw/Terms-and-Conditions> and, for electronic format documents, subject to Terms and Conditions for Electronic Documents at <http://www.sgs.com.tw/Terms-and-Conditions>. Attention is drawn to the limitation of liability, indemnification and jurisdiction issues defined therein. Any holder of this document is advised that information contained hereon reflects the Company's findings at the time of its intervention only and within the limits of client's instruction, if any. The Company's sole responsibility is to its Client and this document does not exonerate parties to a transaction from exercising all their rights and obligations under the transaction documents. This document cannot be reproduced, except in full, without prior written approval of the Company. Any unauthorized alteration, forgery or falsification of the content or appearance of this document is unlawful and offenders may be prosecuted to the fullest extent of the law.

Revision History

Rev.	Issue Date	Revisions	Effect Page	Revised By
00	November 7, 2022	Initial Issue	ALL	Allison Chen

Table of contents

1.	GENERAL INFORMATION.....	4
1.1	EUT INFORMATION.....	4
1.2	EUT CHANNEL INFORMATION.....	5
1.3	ANTENNA INFORMATION.....	5
1.4	MEASUREMENT UNCERTAINTY.....	6
1.5	FACILITIES AND TEST LOCATION.....	7
1.6	INSTRUMENT CALIBRATION.....	8
1.7	SUPPORT AND EUT ACCESSORIES EQUIPMENT.....	10
1.8	TEST METHODOLOGY AND APPLIED STANDARDS.....	10
2.	TEST SUMMARY.....	11
3.	DESCRIPTION OF TEST MODES.....	12
3.1	THE WORST MODE OF OPERATING CONDITION.....	12
3.2	THE WORST MODE OF MEASUREMENT.....	13
3.3	EUT DUTY CYCLE.....	14
4.	TEST RESULT.....	15
4.1	AC POWER LINE CONDUCTED EMISSION.....	15
4.2	6DB BANDWIDTH AND OCCUPIED BANDWIDTH (99%).....	18
4.3	OUTPUT POWER MEASUREMENT.....	26
4.4	POWER SPECTRAL DENSITY.....	29
4.5	CONDUCTED BANDEDGE AND SPURIOUS EMISSION.....	34
4.6	RADIATION BANDEDGE AND SPURIOUS EMISSION.....	44
	APPENDIX 1 - PHOTOGRAPHS OF EUT.....	A-1

Report No.: TMWK2210004067KR





1. GENERAL INFORMATION

1.1 EUT INFORMATION

Applicant	NETRONIX, INC. No. 945, Boai St., Jubei City, Hsin-Chu, 30265, Taiwan
Manufacturer	NETRONIX, INC. No. 945, Boai St., Jubei City, Hsin-Chu, 30265, Taiwan
Equipment	7.8" Digital Note Pad; 7.8" Color Digital Note Pad; 7.8" Digital Reader; 7.8" Color Digital Reader
Model Name	E70P24
Product Discrepancy	Please see remark as below.
Brand Name	MobiScribe
Received Date	August 5, 2022
Date of Test	September 1~October 4, 2022
Power Supply	1. Power from Host System. (DC 5V) 2. Power from Battery. Brand / Model: EVE Energy Co., LTD. / EVE2275A7GH Rating: 3.85VDC, 9.63Wh

Remark:

- For more details, please refer to the User's manual of the EUT.
- Disclaimer: Antenna information is provided by the applicant, test results of this report are applicable to the sample EUT received.
- Disclaimer: Variant information between/among model numbers / trademarks is provided by the applicant, test results of this report are applicable to the sample EUT received of main test model name.
- Model Discrepancy:

Product Name	7.8" Digital Note Pad	7.8" Color Digital Note Pad	7.8" Digital Reader	7.8" Color Digital Reader
Model Name	E70P24			
Button	N/A	N/A	Yes	Yes
Touch Pen	Yes	Yes	N/A	N/A
Panel display	Black and White	Color	Black and White	Color
Appearance				

Report No.: TMWK2210004067KR

1.2 EUT CHANNEL INFORMATION

Frequency Range	802.11b/g/n HT 20: 2412 MHz ~ 2462 MHz
Modulation Type	1. IEEE 802.11b mode: CCK 2. IEEE 802.11g mode: OFDM 3. IEEE 802.11n HT 20 Mode: OFDM
Number of channel	1. IEEE 802.11b mode: 11 Channels 2. IEEE 802.11g mode: 11 Channels 3. IEEE 802.11n HT 20 Mode : 11 Channels

Remark:

Refer as ANSI C63.10: 2013 clause 5.6.1 Table 4 for test channels

Number of frequencies to be tested		
Frequency range in which device operates	Number of frequencies	Location in frequency range of operation
<input type="checkbox"/> 1 MHz or less	1	Middle
<input type="checkbox"/> 1 MHz to 10 MHz	2	1 near top and 1 near bottom
<input checked="" type="checkbox"/> More than 10 MHz	3	1 near top, 1 near middle, and 1 near bottom

1.3 ANTENNA INFORMATION

Antenna Specification	<input type="checkbox"/> PIFA <input checked="" type="checkbox"/> PCB <input type="checkbox"/> Dipole <input type="checkbox"/> Coils
Antenna Gain	Gain: 2.64 dBi
Brand / Model	INPAQ Technology Co., Ltd. / RFPCA310710EMLB301

Notes:

1.The antenna(s) of the EUT are permanently attached and there are no provisions for connection to an external antenna. So the EUT complies with the requirements of §15.203.

Report No.: TMWK2210004067KR

1.4 MEASUREMENT UNCERTAINTY

PARAMETER	UNCERTAINTY
AC Powerline Conducted Emission	± 2.1183
Channel Bandwidth	± 2.1863
RF output power (Power Meter + Power sensor)	± 1.2688
Power Spectral density	± 2.1855
Conducted Bandedge	± 2.1866
Conducted Spurious Emission	± 2.1859
Radiated Emission_9kHz-30MHz	± 3.814
Radiated Emission_30MHz-200MHz	± 4.272
Radiated Emission_200MHz-1GHz	± 4.619
Radiated Emission_1GHz-6GHz	± 5.522
Radiated Emission_6GHz-18GHz	± 5.228
Radiated Emission_18GHz-26GHz	± 4.089
Radiated Emission_26GHz-40GHz	± 4.019

Remark:

- 1.This uncertainty represents an expanded uncertainty expressed at approximately the 95% confidence level using a coverage factor of k=2
2. ISO/IEC 17025 requires that an estimate of the measurement uncertainties associated with the emissions test results be included in the report.

1.5 FACILITIES AND TEST LOCATION

All measurement facilities used to collect the measurement data are located at

No.11, Wugong 6th Rd., Wugu Dist., New Taipei City, Taiwan.

No. 12, Ln. 116, Wugong 3rd Rd., Wugu Dist., New Taipei City, Taiwan.

CAB identifier: TW1309

Test site	Test Engineer	Remark
AC Conduction Room	Tony Chao	-
Radiation	Ray Li, Tony Chao	-
RF Conducted	Jack Chen	-

Remark: The lab has been recognized as the FCC accredited lab. under the KDB 974614 D01 and is listed in the FCC pubic Access Link (PAL) database, FCC Registration No. :444940, the FCC Designation No.:TW1309

Report No.: TMWK2210004067KR

1.6 INSTRUMENT CALIBRATION

RF Conducted Test Site					
Name of Equipment	Manufacturer	Model	Serial Number	Calibration Date	Calibration Due
Coaxial Cable	Woken	SUMITOMO	12	2022-03-02	2023-03-01
Power Meter	Anritsu	ML2496A	2136002	2021-12-06	2022-12-05
EXA Signal Analyzer	Keysight	N9010B	MY60242460	2022-01-30	2023-01-29
Power Sensor	Anritsu	MA2411B	1911386	2022-08-08	2023-08-07
Power Sensor	Anritsu	MA2411B	1911387	2022-08-08	2023-08-07
Software	Radio Test Software Ver. 21				

AC Power-line Conducted Test Room					
Name of Equipment	Manufacturer	Model	Serial Number	Calibration Date	Calibration Due
CABLE	EMCI	CFD300-NL	CERF	2022-06-27	2023-06-26
EMI Test Receiver	R&S	ESCI	100064	2022-06-17	2023-06-16
LISN	SCHAFFNER	NNB 41	03/10013	2022-02-15	2023-02-14
Software	EZ-EMC(CCS-3A1-CE-wugu)				

Remark:

1. Each piece of equipment is scheduled for calibration once a year.
2. N.C.R. = No Calibration Required.

3M 966A Chamber					
Name of Equipment	Manufacturer	Model	Serial Number	Calibration Date	Calibration Due
K-Type Cable	Huber+Suhner	SUCOFLEX 102	29406/2	2021-12-05	2022-12-04
Bi-Log Antenna	Sunol Sciences	JB3	A030105	2022-08-03	2023-08-02
Spectrum Analyzer	Agilent	E4446A	MY46180323	2021-12-06	2022-12-05
Thermo-Hygro Meter	WISEWIND	1206	D07	2021-12-28	2022-12-27
Loop Antenna	COM-POWER	AL-130	121051	2022-04-13	2023-04-12
Coaxial Cable	EMCI	EMC101G- KM-KM-500	211041	2021-12-23	2022-12-22
Coaxial Cable	EMC	EMC101G-KM-KM-9000	211042	2021-12-23	2022-12-22
Horn Antenna	ETS LINDGREN	3116	00026370	2021-11-30	2022-11-29
Cable	Woken	J-1099	201709090004	2021-12-23	2022-12-22
Preamplifier	EMEC	EM330	060609	2022-02-23	2023-02-22
Preamplifier	HP	8449B	3008A00965	2021-12-24	2022-12-23
Band Reject Filter	MICRO TRONICS	BRM 50702	112	2021-11-23	2022-11-22
Cable	Huber+Suhner	104PEA	20995+11112+182330	2022-02-23	2023-02-22
Coaxial Cable	EMCI	EMC105	190914+33953	2022-06-15	2023-06-14
Horn Antenna	ETC	MCTD 1209	DRH13M02003	2022-01-25	2023-01-24
Turn Table	CCS	CC-T-1F	N/A	N.C.R	N.C.R
Controller	CCS	CC-C-1F	N/A	N.C.R	N.C.R
Antenna Tower	CCS	CC-A-1F	N/A	N.C.R	N.C.R
Software	e3 6.11-20180419c				

Remark:

1. Each piece of equipment is scheduled for calibration once a year.
2. N.C.R. = No Calibration Required.

1.7 SUPPORT AND EUT ACCESSORIES EQUIPMENT

EUT Accessories Equipment						
No.	Equipment	Brand	Model	Series No.	FCC ID	IC
	N/A					

Support Equipment						
No.	Equipment	Brand	Model	Series No.	FCC ID	IC
1	NB(E)	Lenovo	IBM 7663	N/A	PD97260H	N/A
2	NB(G)	Lenovo	IBM 1951	N/A	N/A	N/A
3	Adapter	SAMSUNG	ETA-U90JWS	N/A	N/A	N/A

1.8 TEST METHODOLOGY AND APPLIED STANDARDS

The test methodology, setups and results comply with all requirements in accordance with ANSI C63.10:2013, FCC Part 2, FCC Part 15.247 and KDB 558074 D01.

2. TEST SUMMARY

FCC Standard Section	Report Section	Test Item	Result
15.203	1.3	Antenna Requirement	Pass
15.207(a)	4.1	AC Conducted Emission	Pass
15.247(a)(2)	4.2	6 dB Bandwidth	Pass
-	4.2	Occupied Bandwidth (99%)	Pass
15.247(b)	4.3	Output Power Measurement	Pass
15.247(e)	4.4	Power Spectral Density	Pass
15.247(d)	4.5	Conducted Band Edge	Pass
15.247(d)	4.5	Conducted Spurious Emission	Pass
15.247(d)	4.6	Radiation Band Edge	Pass
15.247(d)	4.6	Radiation Spurious Emission	Pass

Report No.: TMWK2210004067KR

3. DESCRIPTION OF TEST MODES

3.1 THE WORST MODE OF OPERATING CONDITION

Operation mode	IEEE 802.11b mode :1Mbps IEEE 802.11g mode :6Mbps IEEE 802.11n HT20 mode :MCS0
Test Channel Frequencies	IEEE 802.11b mode : Low CH: 2412 MHz Mid CH: 2437 MHz High CH: 2462 MHz IEEE 802.11g mode : Low CH: 2412 MHz Mid CH: 2437 MHz High CH: 2462 MHz IEEE 802.11n HT20 mode : Low CH: 2412 MHz Mid CH: 2437 MHz High CH: 2462 MHz
Operation Transmitter	IEEE 802.11b mode : 1T1R IEEE 802.11g mode : 1T1R IEEE 802.11n HT20 mode : 1T1R

Remark:

1. EUT pre-scanned data rate of output power for each mode, the worst data rate were recorded in this report.
2. The worst-case data rates are determined to be as follows for each mode based upon investigations by measuring the average power and PSD across all data rates, bandwidths, and modulations.

Report No.: TMWK2210004067KR

3.2 THE WORST MODE OF MEASUREMENT

AC Power Line Conducted Emission	
Test Condition	AC Power line conducted emission for line and neutral
Power supply Mode	Mode 1: EUT (7.8" Digital Note Pad) power by Adapter Mode 2: EUT (7.8" Digital Reader) power by Adapter Mode 3: EUT (7.8" Color Digital Note Pad) power by Adapter Mode 4: EUT (7.8" Color Digital Reader) power by Adapter
Worst Mode	<input checked="" type="checkbox"/> Mode 1 <input type="checkbox"/> Mode 2 <input type="checkbox"/> Mode 3 <input type="checkbox"/> Mode 4

Radiated Emission Measurement Below 1G	
Test Condition	Radiated Emission Below 1G
Power supply Mode	Mode 1: EUT (7.8" Digital Reader) power by Host System Mode 2: EUT (7.8" Digital Note Pad) power by Host System Mode 3: EUT (7.8" Color Digital Reader) power by Host System Mode 4: EUT (7.8" Color Digital Note Pad) power by Host System
Worst Mode	<input checked="" type="checkbox"/> Mode 1 <input checked="" type="checkbox"/> Mode 2 <input checked="" type="checkbox"/> Mode 3 <input checked="" type="checkbox"/> Mode 4

Radiated Emission Measurement Above 1G	
Test Condition	Radiated Emission Above 1G
Power supply Mode	Mode 1: EUT (7.8" Digital Reader) power by Host System Mode 2: EUT (7.8" Digital Note Pad) power by Host System Mode 3: EUT (7.8" Color Digital Reader) power by Host System Mode 4: EUT (7.8" Color Digital Note Pad) power by Host System
Worst Mode	<input type="checkbox"/> Mode 1 <input type="checkbox"/> Mode 2 <input type="checkbox"/> Mode 3 <input checked="" type="checkbox"/> Mode 4
Worst Position	<input type="checkbox"/> Placed in fixed position. <input checked="" type="checkbox"/> Placed in fixed position at X-Plane (E2-Plane) <input type="checkbox"/> Placed in fixed position at Y-Plane (E1-Plane) <input type="checkbox"/> Placed in fixed position at Z-Plane (H-Plane)

Remark:

1. The worst mode was record in this test report.
2. EUT pre-scanned in three axis ,X,Y, Z and two polarity, for radiated measurement. The worst case(X-Plane) were recorded in this report.
3. Samples are available in four configurations. RF hardware components and antenna parts are the same. For different configurations, RSE is evaluated at below 1GHz and ac line, all test items are tested using the worst model.
4. AC power line conducted emission were performed the EUT transmit at the highest output power channel as worst case.
5. Radiation emission (below 1GH) were performed the EUT transmit at the IEEE802.11b mode's middle channel as worst case.



Report No.: TMWK2210004067KR

3.3 EUT DUTY CYCLE

Temperature: 22.3~25.5°C **Test date:** September 1~October 4, 2022
Humidity: 50~56% RH **Tested by:** Jack Chen

Duty Cycle				
Configuration	Duty Cycle (%)	Duty Factor (dB) =10*log (1/Duty Cycle)	1/T (kHz)	VBW setting (kHz)
802.11b	99.47	0.02	0.05	0.01
802.11g	96.82	0.14	0.32	1.00
802.11n_20	97.91	0.09	0.21	1.00

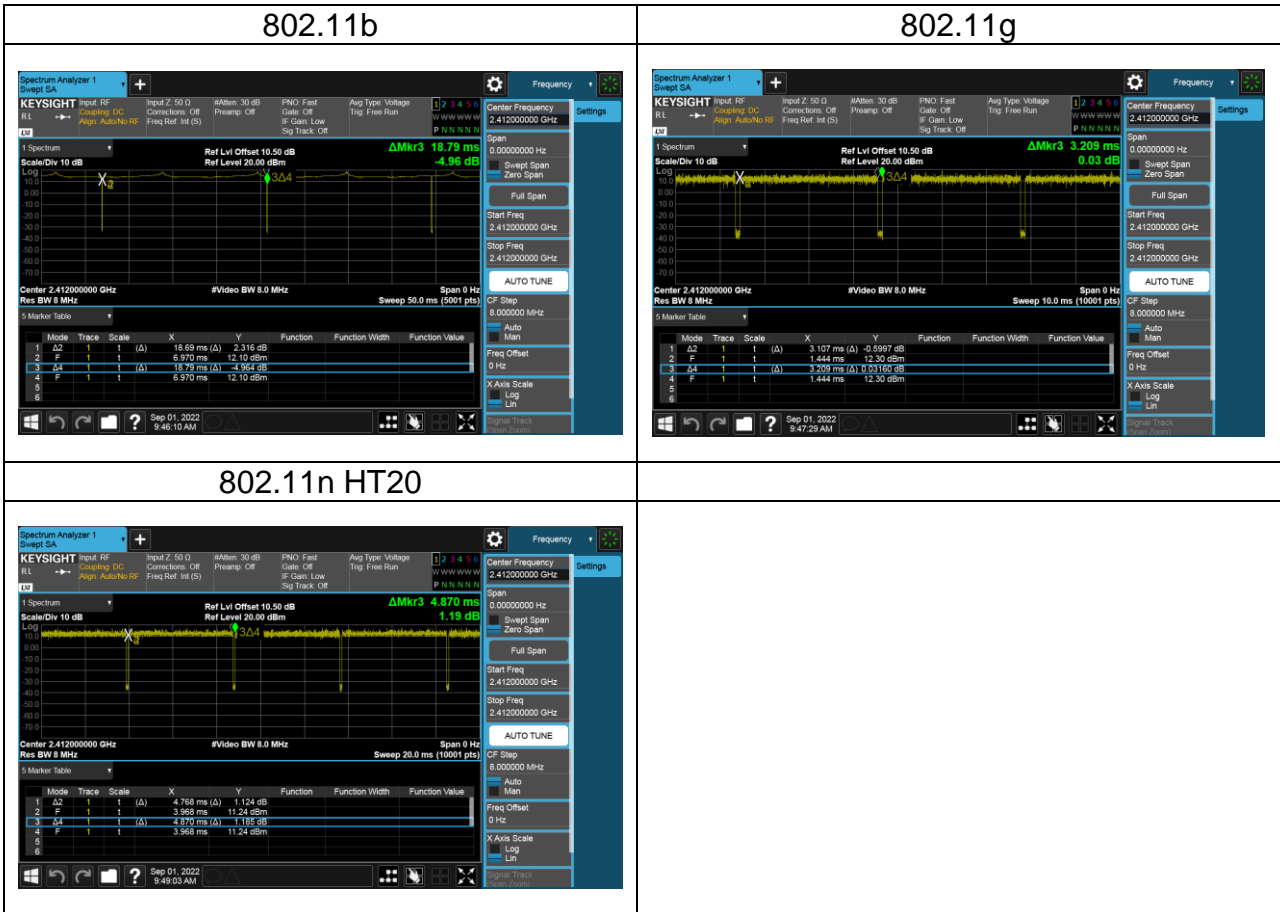

Report No.: TMWK2210004067KR

4. TEST RESULT

4.1 AC POWER LINE CONDUCTED EMISSION

4.1.1 Test Limit

According to §15.207(a)(2)

Frequency Range (MHz)	Limits(dB μ V)	
	Quasi-peak	Average
0.15 to 0.50	66 to 56*	56 to 46*
0.50 to 5	56	46
5 to 30	60	50

* Decreases with the logarithm of the frequency.

4.1.2 Test Procedure

Test method Refer as ANSI C63.10: 2013 clause 6.2,

1. The EUT was placed on a non-conducted table, which is 0.8m above horizontal ground plane and 0.4m above vertical ground plane.
2. EUT connected to the line impedance stabilization network (LISN)
3. Receiver set RBW of 9kHz and Detector Peak, and note as quasi-peak and average.
4. Maximum procedure was performed on the six highest emissions to ensure EUT compliance.
5. Recorded Line for Neutral and Line.

4.1.3 Test Setup

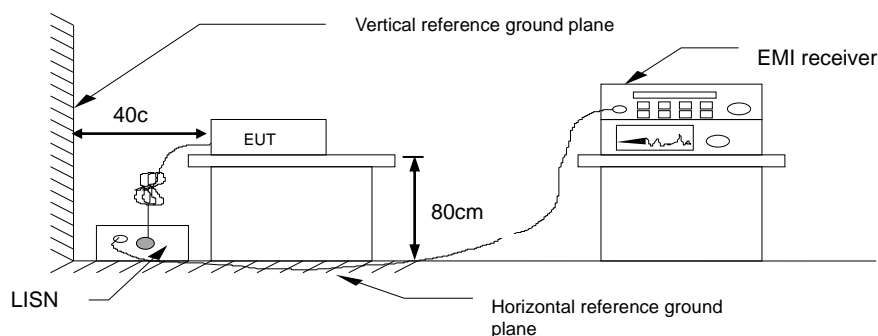

4.1.4 Test Result

PASS.

Report No.: TMWK2210004067KR

Test Data

Test Mode:	Mode 1	Temp/Hum	25.3(°C)/ 531%RH
Phase:	Line	Test Date	September 14, 2022
Test Voltage:	120Vac, 60Hz	Test Engineer	Tony Chao

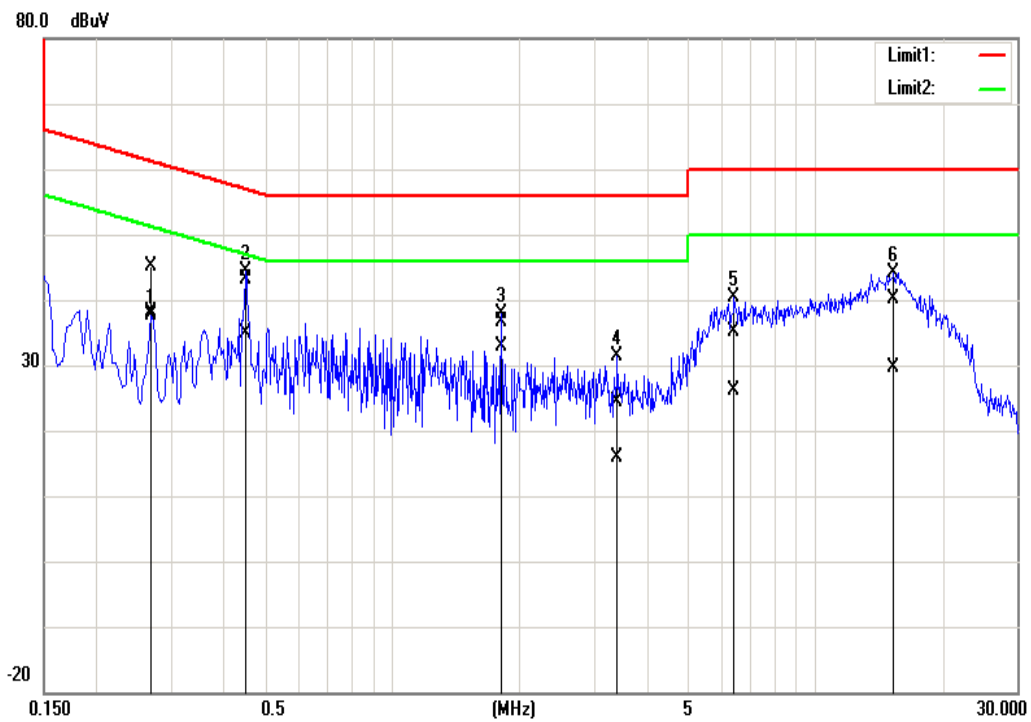

Frequency (MHz)	Quasi Peak reading (dBuV)	Average reading (dBuV)	Correction factor (dB)	Quasi Peak result (dBuV)	Average result (dBuV)	Quasi Peak limit (dBuV)	Average limit (dBuV)	Quasi Peak margin (dB)	Average margin (dB)	Remark
0.2700	34.85	27.86	10.18	45.03	38.04	61.12	51.12	-16.09	-13.08	Pass
0.4500	32.86	24.80	10.19	43.05	34.99	56.88	46.88	-13.83	-11.89	Pass
1.8100	26.46	22.55	10.25	36.71	32.80	56.00	46.00	-19.29	-13.20	Pass
3.4100	14.05	5.71	10.28	24.33	15.99	56.00	46.00	-31.67	-30.01	Pass
6.4420	24.81	15.81	10.32	35.13	26.13	60.00	50.00	-24.87	-23.87	Pass
15.3180	29.83	19.15	10.37	40.20	29.52	60.00	50.00	-19.80	-20.48	Pass

Note: Correction factor = LISN loss + Cable loss.

Test Mode:	Mode 1	Temp/Hum	25.3(°C)/ 531%RH
Phase:	Neutral	Test Date	September 14, 2022
Test Voltage:	120Vac, 60Hz	Test Engineer	Tony Chao

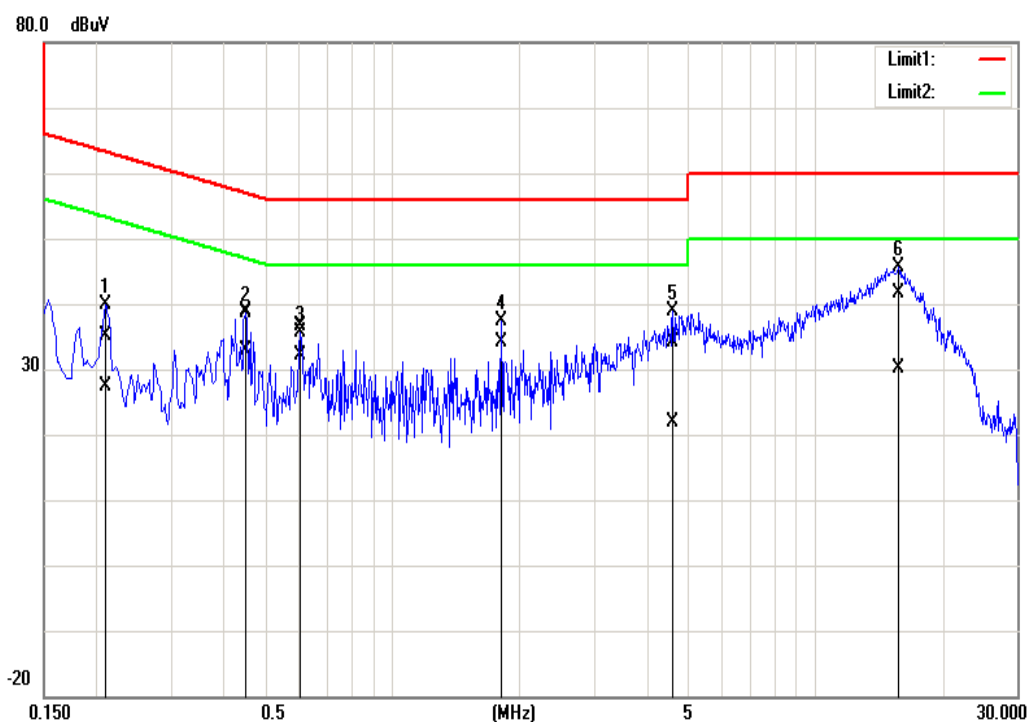

Frequency (MHz)	Quasi Peak reading (dBuV)	Average reading (dBuV)	Correction factor (dB)	Quasi Peak result (dBuV)	Average result (dBuV)	Quasi Peak limit (dBuV)	Average limit (dBuV)	Quasi Peak margin (dB)	Average margin (dB)	Remark
0.2100	24.85	17.19	10.17	35.02	27.36	63.21	53.21	-28.19	-25.85	Pass
0.4500	28.59	22.60	10.18	38.77	32.78	56.88	46.88	-18.11	-14.10	Pass
0.6060	26.44	21.96	10.18	36.62	32.14	56.00	46.00	-19.38	-13.86	Pass
1.8140	27.17	23.96	10.23	37.40	34.19	56.00	46.00	-18.60	-11.81	Pass
4.6140	23.76	11.55	10.28	34.04	21.83	56.00	46.00	-21.96	-24.17	Pass
15.7300	31.19	19.67	10.38	41.57	30.05	60.00	50.00	-18.43	-19.95	Pass

Note: Correction factor = LISN loss + Cable loss.

Report No.: TMWK2210004067KR

4.2 6dB BANDWIDTH AND OCCUPIED BANDWIDTH (99%)

4.2.1 Test Limit

According to §15.247(a)(2)

6 dB Bandwidth :

Limit	Shall be at least 500kHz
-------	--------------------------

Occupied Bandwidth(99%) : For reporting purposes only.

4.2.2 Test Procedure

Test method Refer as ANSI C63.10: 2013,

1. The EUT RF output connected to the spectrum analyzer by RF cable.
2. Setting maximum power transmit of EUT
3. SA set RBW = 100kHz, VBW = 300kHz and Detector = Peak, to measurement 6 dB Bandwidth.
4. SA set RBW = 1% ~ 5% OBW, VBW = three times the RBW and Detector = Peak, to measurement 99% Bandwidth
5. Measure and record the result of 6 dB Bandwidth and 99% Bandwidth. in the test report.

4.2.3 Test Setup

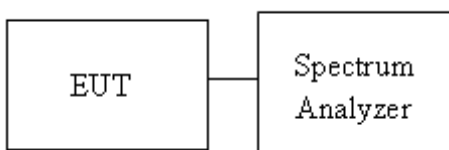

Report No.: TMWK2210004067KR

4.2.4 Test Result

Temperature: 22.3~25.5°C Test date: September 1~October 4, 2022
Humidity: 50~56% RH Tested by: Jack Chen

Test mode: IEEE 802.11b mode / 2412-2462 MHz

Channel	Frequency (MHz)	Chain 0 OBW(99%) (MHz)	Chain 0 6dB BW (kHz)	6dB limit (kHz)
Low	2412	13.489	10110.00	≥500
Mid	2437	13.487	10110.00	
High	2462	13.496	10110.00	

Test mode: IEEE 802.11g mode / 2412-2462 MHz

Channel	Frequency (MHz)	Chain 0 OBW(99%) (MHz)	Chain 0 6dB BW (kHz)	6dB limit (kHz)
Low	2412	16.809	16420.00	≥500
Mid	2437	16.800	16410.00	
High	2462	16.793	16410.00	

Test mode: IEEE 802.11n HT 20 mode / 2412-2462 MHz

Channel	Frequency (MHz)	Chain 0 OBW(99%) (MHz)	Chain 0 6dB BW (kHz)	6dB limit (kHz)
Low	2412	17.709	17600.00	≥500
Mid	2437	17.719	17610.00	
High	2462	17.701	17590.00	

Report No.: TMWK2210004067KR

Test Data

6dB BANDWIDTH

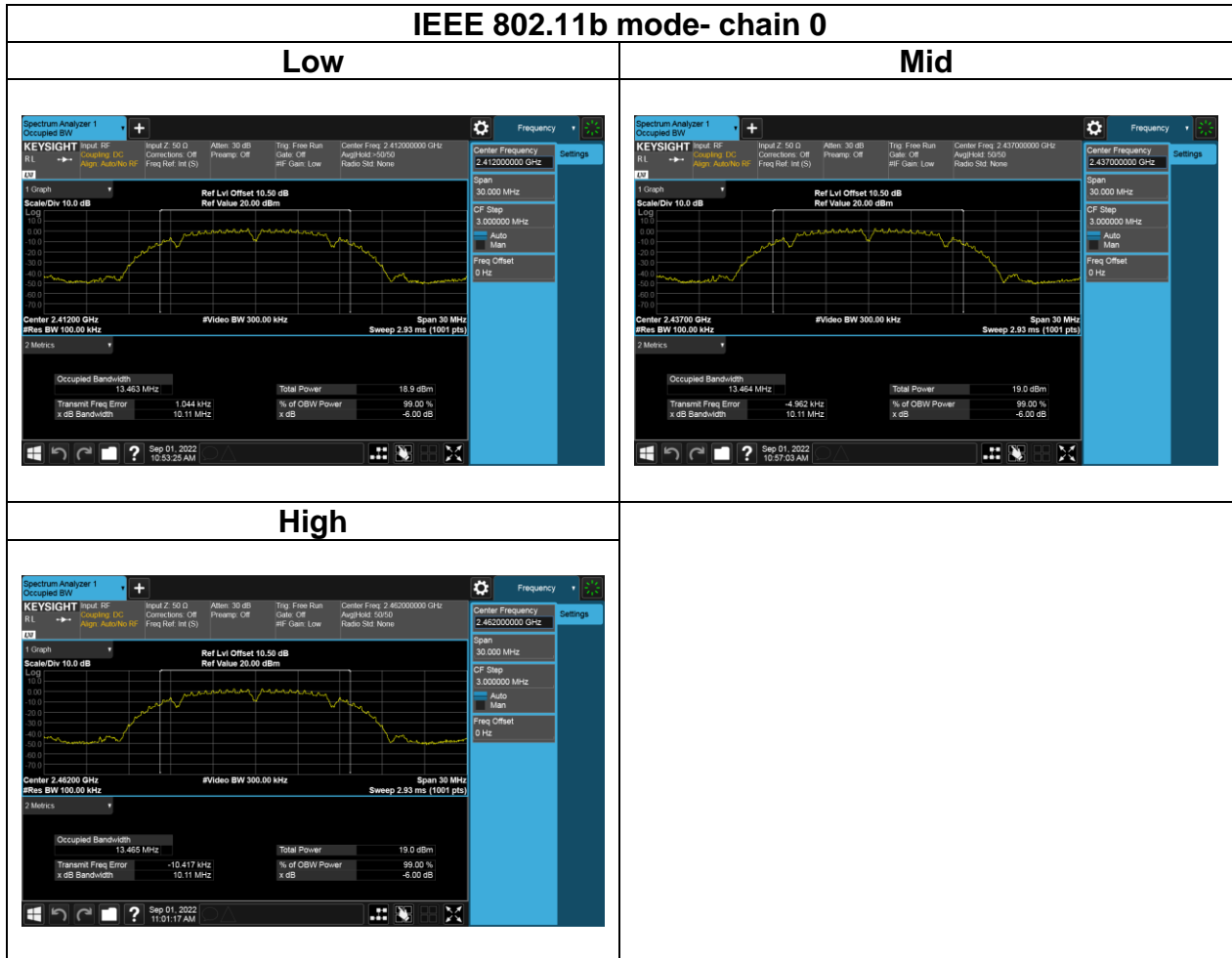

Report No.: TMWK2210004067KR

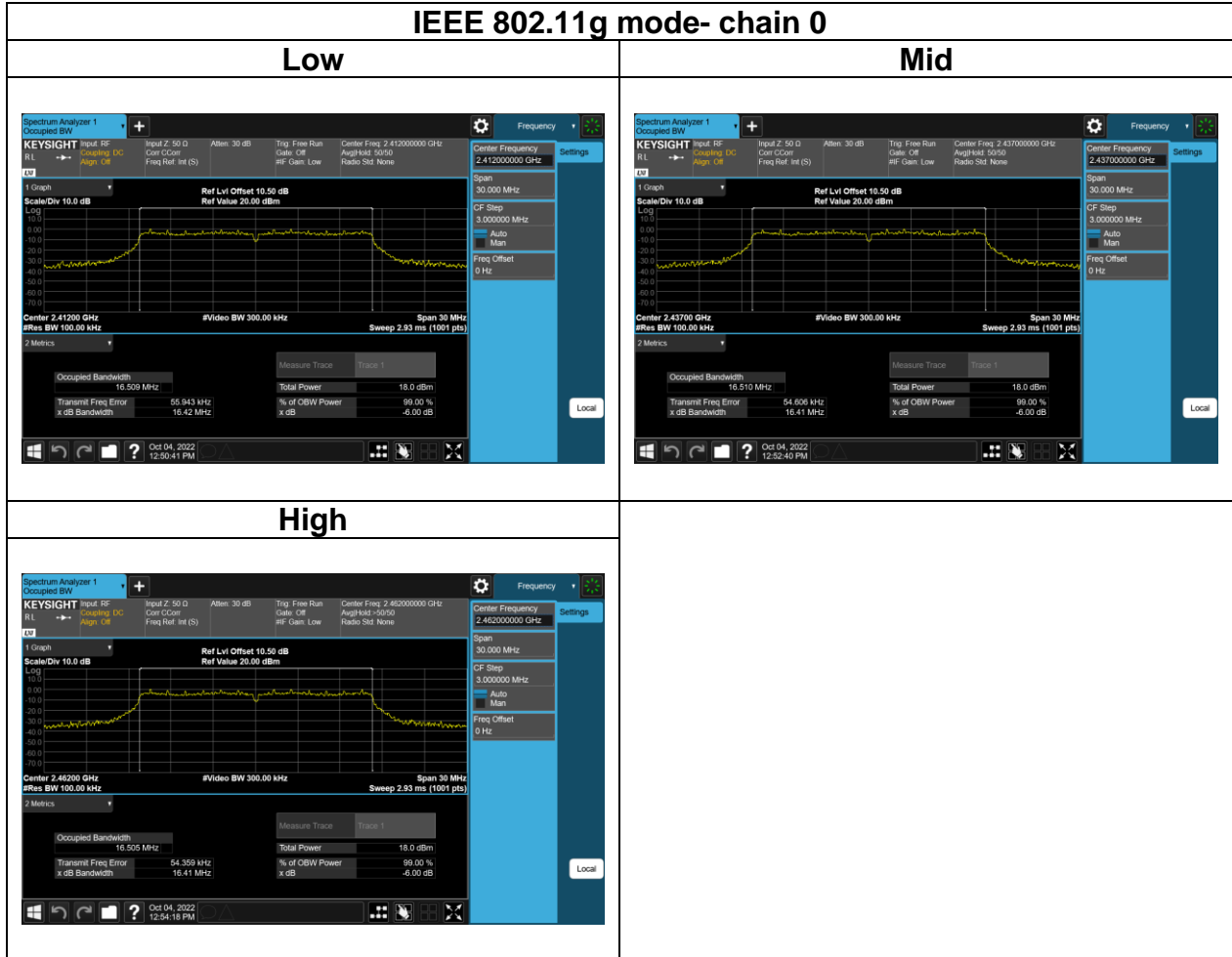

Report No.: TMWK2210004067KR

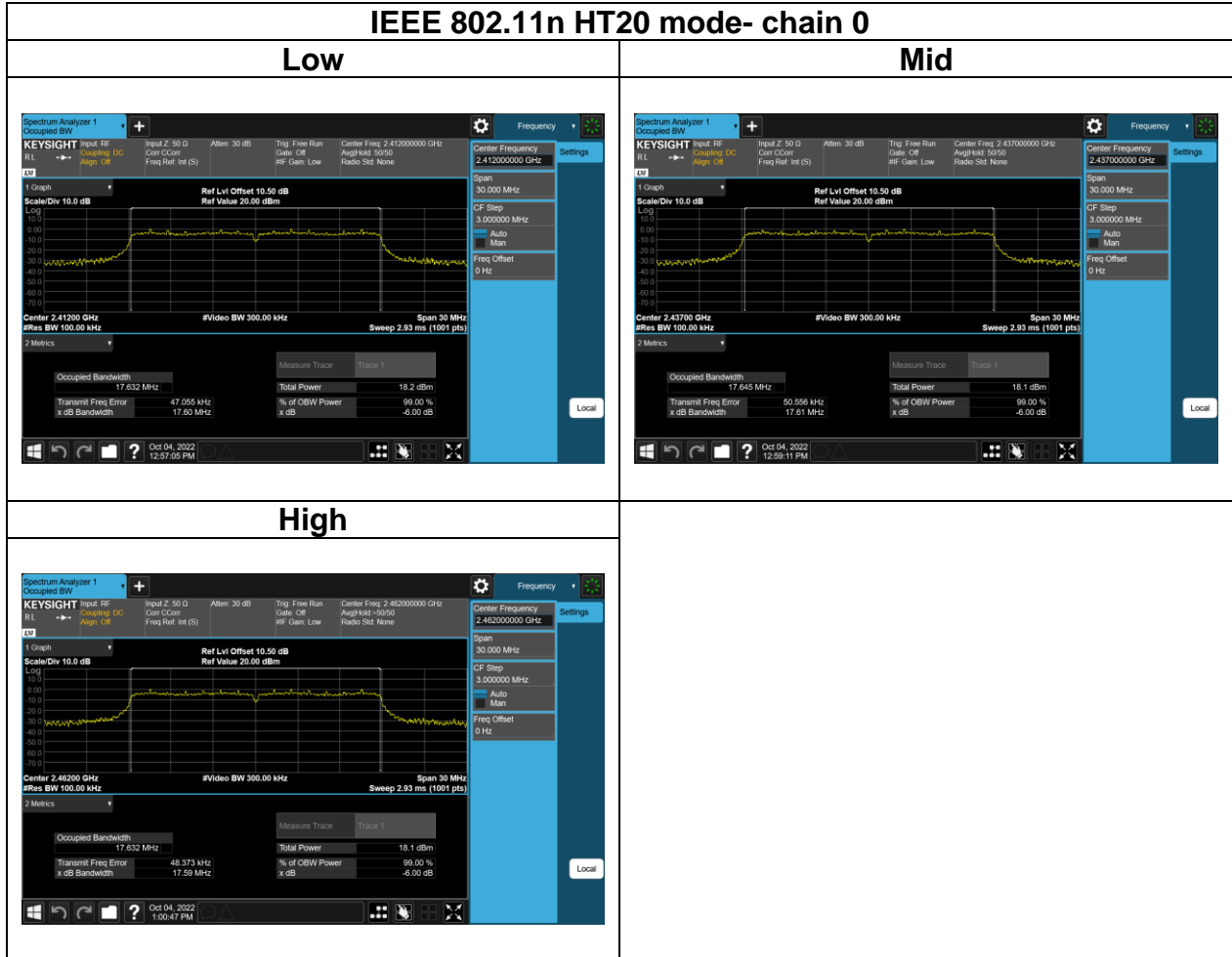

Report No.: TMWK2210004067KR

Test Data

BANDWIDTH 99%

IEEE 802.11b mode- chain 0

Low

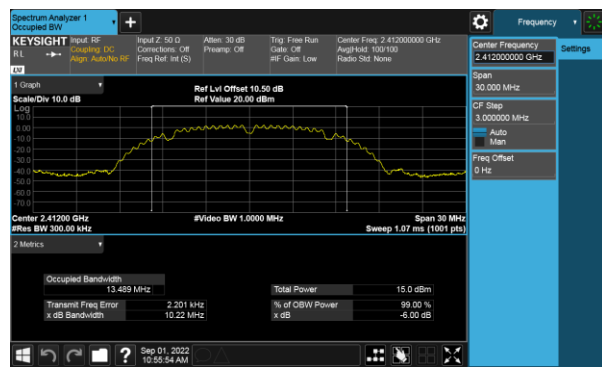

Mid

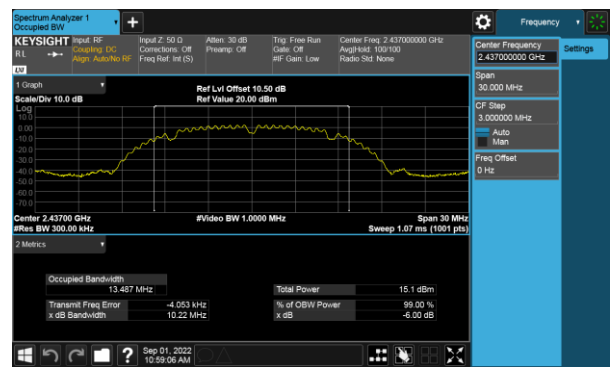

High



Report No.: TMWK2210004067KR

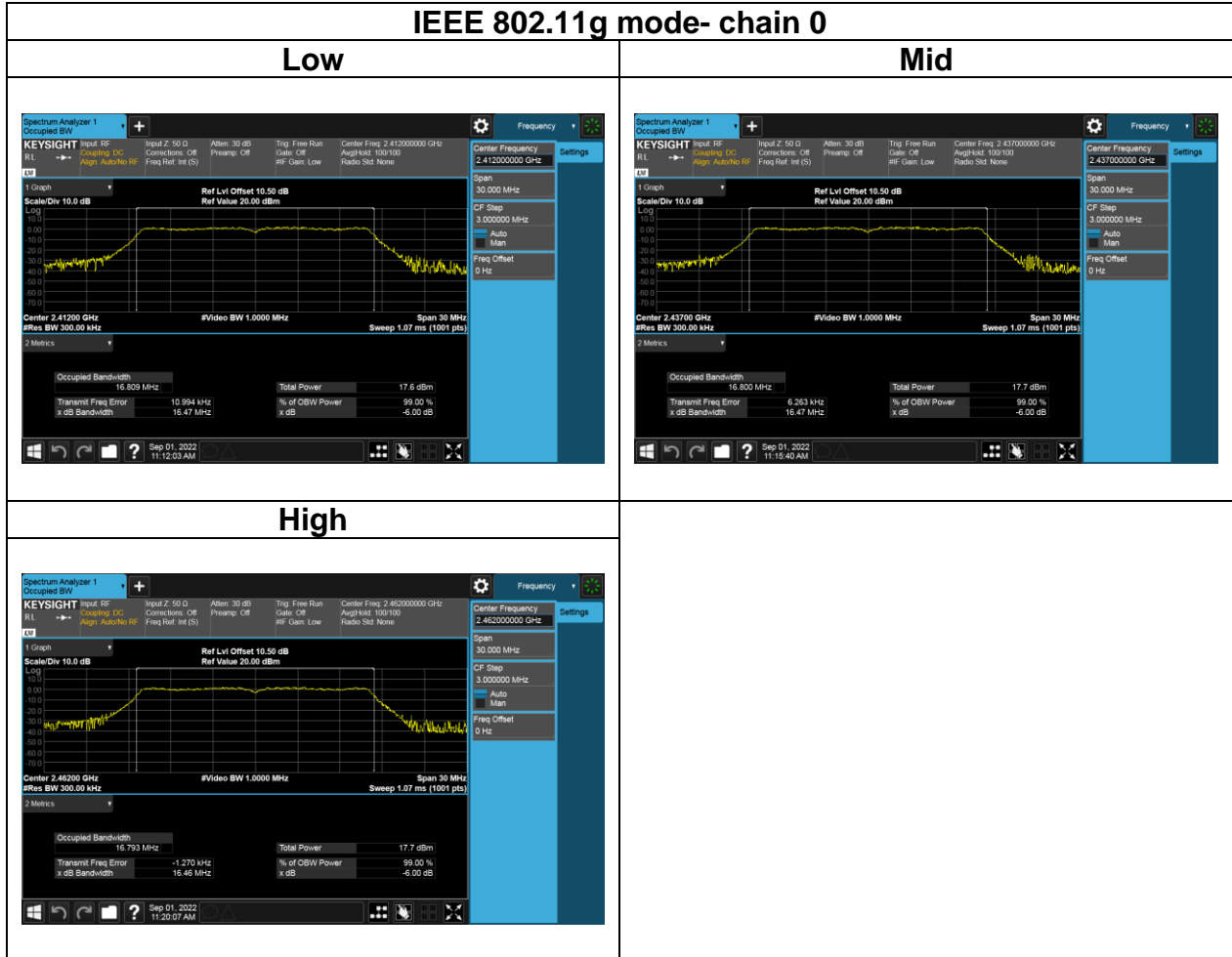

Report No.: TMWK2210004067KR

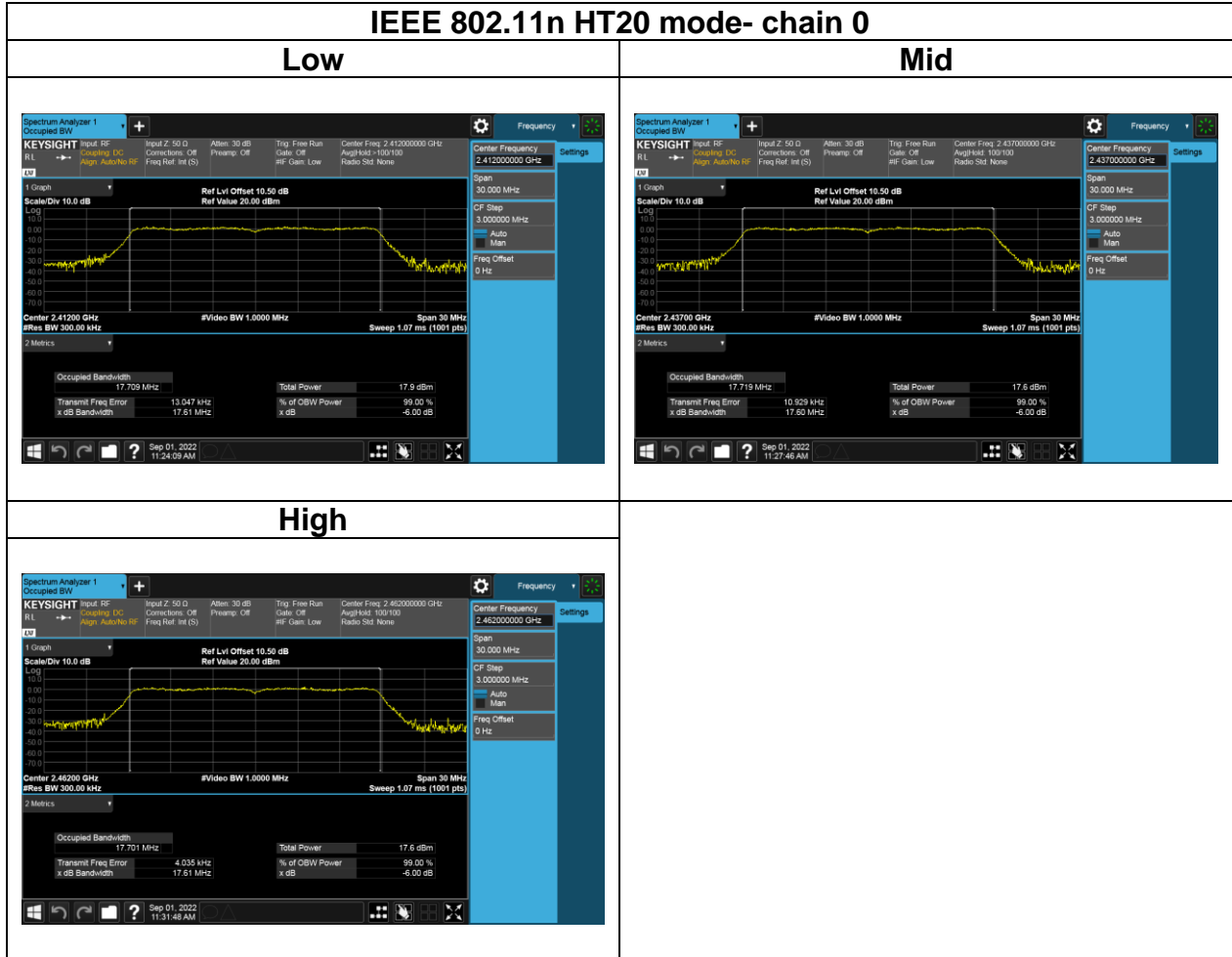

4.3 OUTPUT POWER MEASUREMENT

4.3.1 Test Limit

According to §15.247(b)

Peak output power :

For systems using digital modulation in the 2400-2483.5 MHz, and 5725-5850 MHz bands: 1 Watt(30 dBm) and the e.i.r.p. shall not exceed 4Watt(36 dBm), base on the use of antennas with directional gain not exceed 6 dBi If transmitting antennas of directional gain greater than 6dBi are used the peak output power the conducted output power from the intentional radiator shall be reduced by the amount in dB that the directional gain of the antenna exceeds 6 dBi. In case of point-to-point operation, the limit has to be reduced by 1dB for every 3 dB that the directional gain of the antenna exceeds 6 dBi.

Limit	<input checked="" type="checkbox"/> Antenna not exceed 6 dBi : 30dBm <input type="checkbox"/> Antenna with DG greater than 6 dBi : [Limit = 30 – (DG – 6)] <input type="checkbox"/> Point-to-point operation :
-------	---

Average output power : For reporting purposes only.

4.3.2 Test Procedure

Test method Refer as ANSI C63.10:2013.

1. The EUT RF output connected to the power meter by RF cable.
2. Setting maximum power transmit of EUT.
3. The path loss was compensated to the results for each measurement.
4. Measure and record the result of Peak output power and Average output power. in the test report.

4.3.3 Test Setup

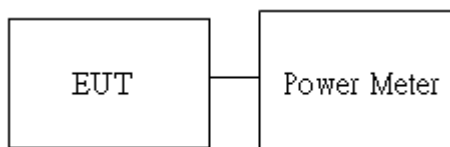

Report No.: TMWK2210004067KR

4.3.4 Test Result

Temperature: 22.3~25.5°C Test date: September 1~October 4, 2022
Humidity: 50~56% RH Tested by: Jack Chen

Peak output power :

Test Mode: IEEE 802.11b Mode

802.11b Ch0						
CH	Freq. (MHz)	Data Rate	Power set	Peak Output Power (dBm)	Limit (dBm)	RESULT
1	2412	1	11	15.41	30.00	PASS
6	2437	1	11	15.35	30.00	PASS
11	2462	1	11	15.42	30.00	PASS

Test Mode: IEEE 802.11g Mode

802.11g Ch0						
CH	Freq. (MHz)	Data Rate	Power set	Peak Output Power (dBm)	Limit (dBm)	RESULT
1	2412	6	11	22.43	30.00	PASS
6	2437	6	11	22.62	30.00	PASS
11	2462	6	11	22.59	30.00	PASS

Test Mode: IEEE 802.11n HT20 Mode

802.11n_HT_20M Ch0						
CH	Freq. (MHz)	Data Rate	Power set	Peak Output Power (dBm)	Limit (dBm)	RESULT
1	2412	MCS0	11	23.02	30.00	PASS
6	2437	MCS0	11	22.86	30.00	PASS
11	2462	MCS0	11	22.72	30.00	PASS

Report No.: TMWK2210004067KR

Average output power :

Test Mode: IEEE 802.11b Mode

802.11b Ch0				
CH	Freq. (MHz)	Data Rate	Power set	Max. Avg. Output Power (dBm)
1	2412	1	11	12.74
6	2437	1	11	12.72
11	2462	1	11	12.76

Test Mode: IEEE 802.11g Mode

802.11g Ch0				
CH	Freq. (MHz)	Data Rate	Power set	Max. Avg. Output Power (dBm)
1	2412	6	11	12.48
6	2437	6	11	12.47
11	2462	6	11	12.43

Test Mode: IEEE 802.11n HT20 Mode

802.11n_HT_20M Ch0				
CH	Freq. (MHz)	Data Rate	Power set	Max. Avg. Output Power (dBm)
1	2412	MCS0	11	12.74
6	2437	MCS0	11	12.70
11	2462	MCS0	11	12.69

Report No.: TMWK2210004067KR

4.4 POWER SPECTRAL DENSITY

4.4.1 Test Limit

According to §15.247(e)

For digitally modulated systems, the power spectral density conducted from the intentional radiator to the antenna shall not be greater than 8 dBm in any 3 kHz band during any time interval of continuous transmission.

Limit	<input checked="" type="checkbox"/> Antenna not exceed 6 dBi : 8dBm <input type="checkbox"/> Antenna with DG greater than 6 dBi : [Limit = 8 – (DG – 6)] <input type="checkbox"/> Point-to-point operation :
-------	---

4.4.2 Test Procedure

Test method Refer as ANSI C63.10:2013,

1. The EUT RF output connected to the spectrum analyzer by RF cable.
2. Setting maximum power transmit of EUT
3. SA set RBW = 3kHz, VBW = 10kHz, Span = 1.5 times DTS Bandwidth (6 dB BW), Detector = Peak, Sweep Time = Auto and Trace = Max hold.
4. The path loss and Duty Factor were compensated to the results for each measurement by SA.
5. Mark the maximum level.
6. Measure and record the result of power spectral density. in the test report.

4.4.3 Test Setup



Report No.: TMWK2210004067KR

4.4.4 Test Result

Temperature: 22.3~25.5°C Test date: September 1~October 4, 2022
Humidity: 50~56% RH Tested by: Jack Chen

Test mode: IEEE 802.11b mode / 2412-2462 MHz

Channel	Frequency (MHz)	Chain 0 PPSD (dBm)	Total PPSD (dBm/3kHz)	Limit (dBm/3kHz)
Low	2412	-8.79	-8.79	8.00
Mid	2437	-7.27	-7.27	
High	2462	-8.73	-8.73	

Test mode: IEEE 802.11g mode / 2412-2462 MHz

Channel	Frequency (MHz)	Chain 0 PPSD (dBm)	Total PPSD (dBm/3kHz)	Limit (dBm/3kHz)
Low	2412	-15.72	-15.72	8.00
Mid	2437	-16.00	-16.00	
High	2462	-15.87	-15.87	

Test mode: IEEE 802.11n HT20 mode / 2412-2462 MHz

Channel	Frequency (MHz)	Chain 0 PPSD (dBm)	Total PPSD (dBm/3kHz)	Limit (dBm/3kHz)
Low	2412	-14.70	-14.70	8.00
Mid	2437	-14.86	-14.86	
High	2462	-14.47	-14.47	

Report No.: TMWK2210004067KR

Test Data

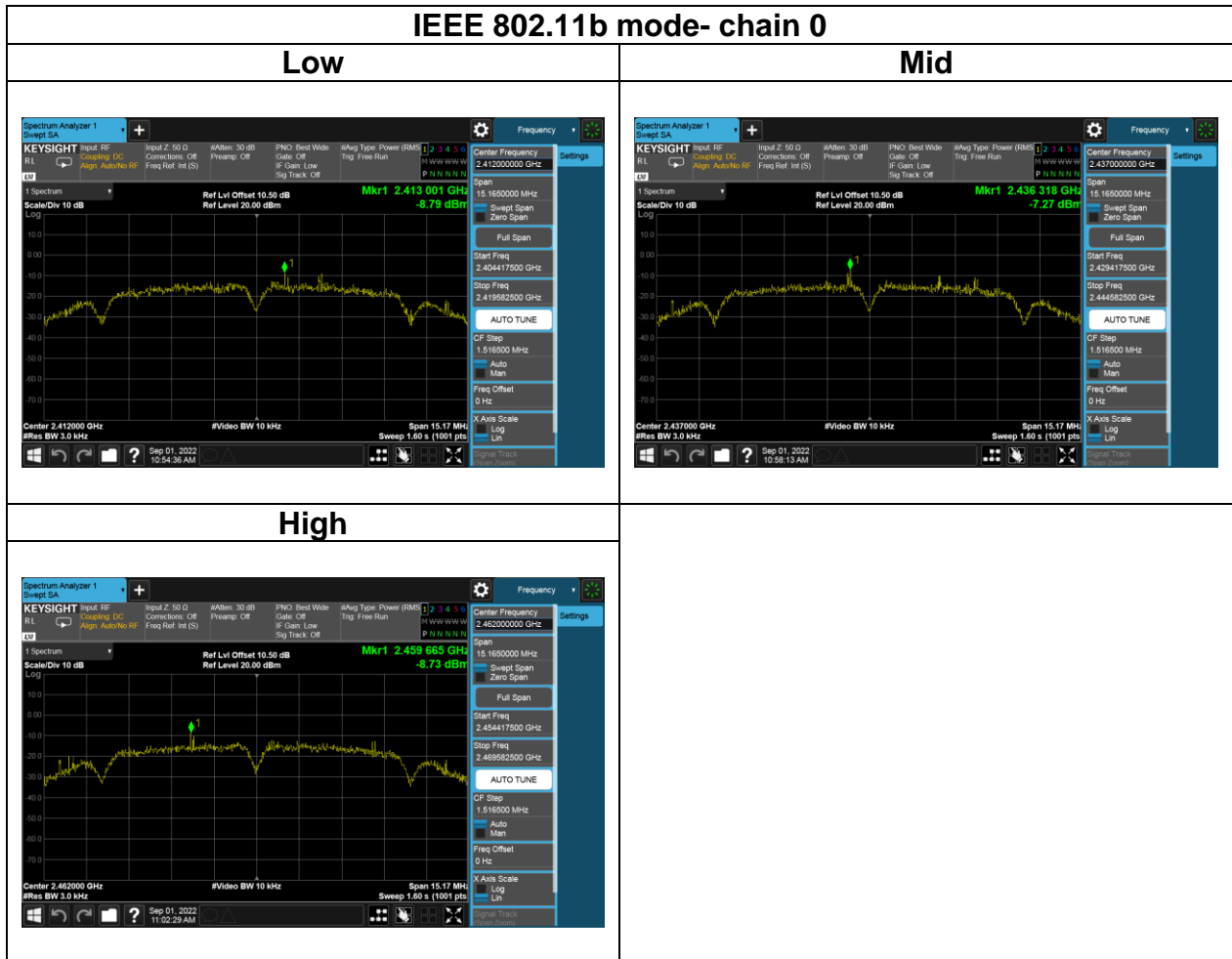

Report No.: TMWK2210004067KR

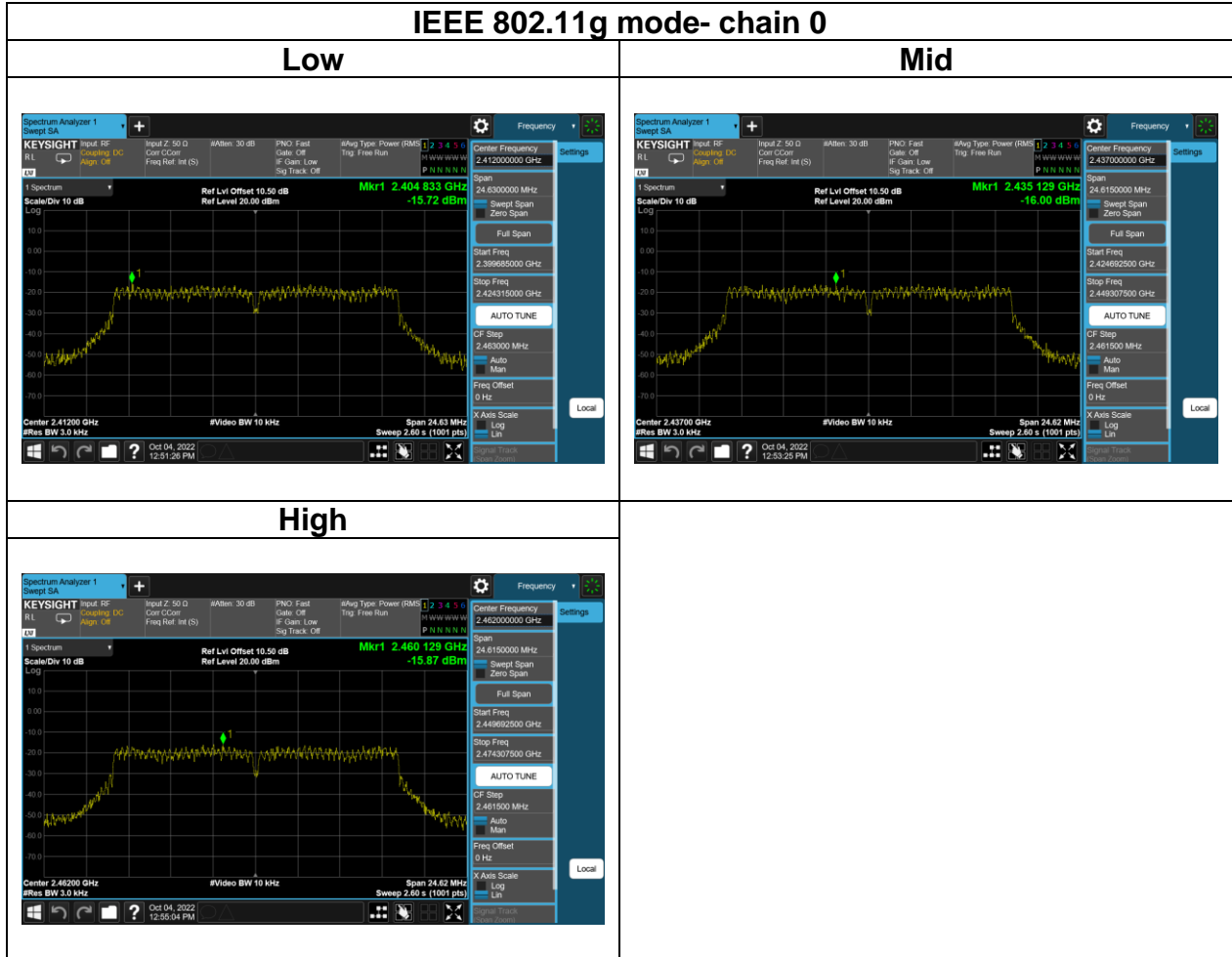

Report No.: TMWK2210004067KR

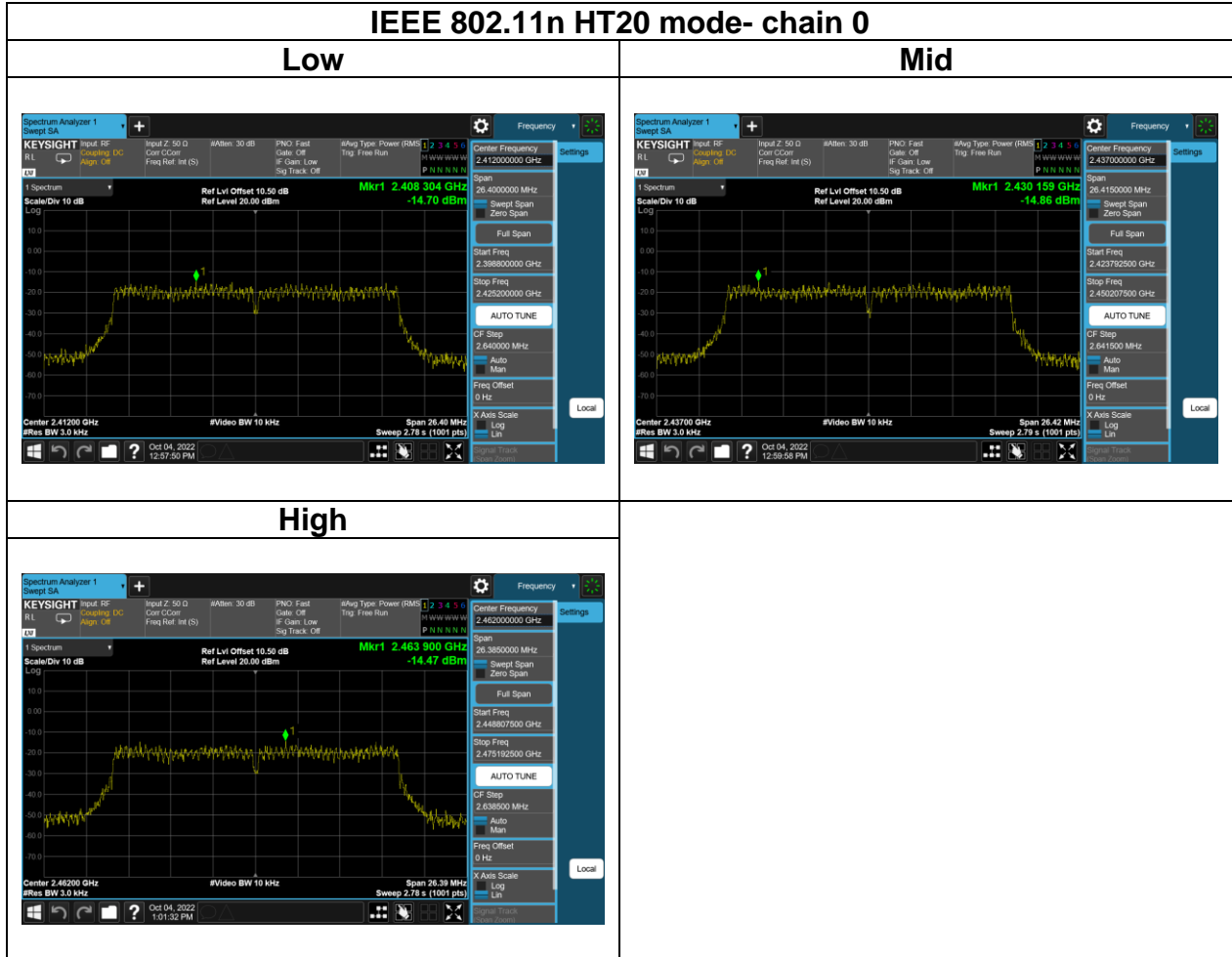

4.5 CONDUCTED BANDEDGE AND SPURIOUS EMISSION

4.5.1 Test Limit

According to §15.247(d),

In any 100 kHz bandwidth outside the authorized frequency band,

Non-restricted bands shall be attenuated at least 20 dB/30 dB relative to the maximum PSD level in 100 kHz by RF conducted or a radiated measurement which fall in the restricted bands, as defined in §15.205(a), must also comply with the radiated emission limits specified in §15.209(a).

4.5.2 Test Procedure

Test method Refer as ANSI C63.10:2013.

1. EUT RF output port connected to the SA by RF cable, and the path loss was compensated to result.
2. SA setting, RBW=100kHz, VBW=300kHz, Detector=Peak, Trace mode = max hold, SWT = Auto.
3. In any 100 kHz bandwidth outside the authorized frequency band, shall be attenuated at least 20 dB relative to the maximum in-band peak PSD level in 100 kHz when conducted power procedure is used. If the transmitter complies with the conducted power limits based on the use of RMS averaging over a time interval, the attenuation required under this paragraph shall be 30 dB instead of 20 dB.

4.5.3 Test Setup

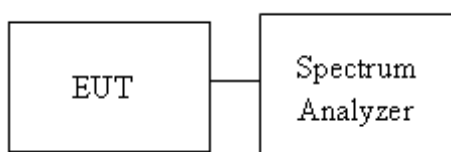

4.5.4 Test Result

Temperature:	22.3~25.5°C	Test date:	September 1~October 4, 2022
Humidity:	50~56% RH	Tested by:	Jack Chen



Report No.: TMWK2210004067KR

Test Data

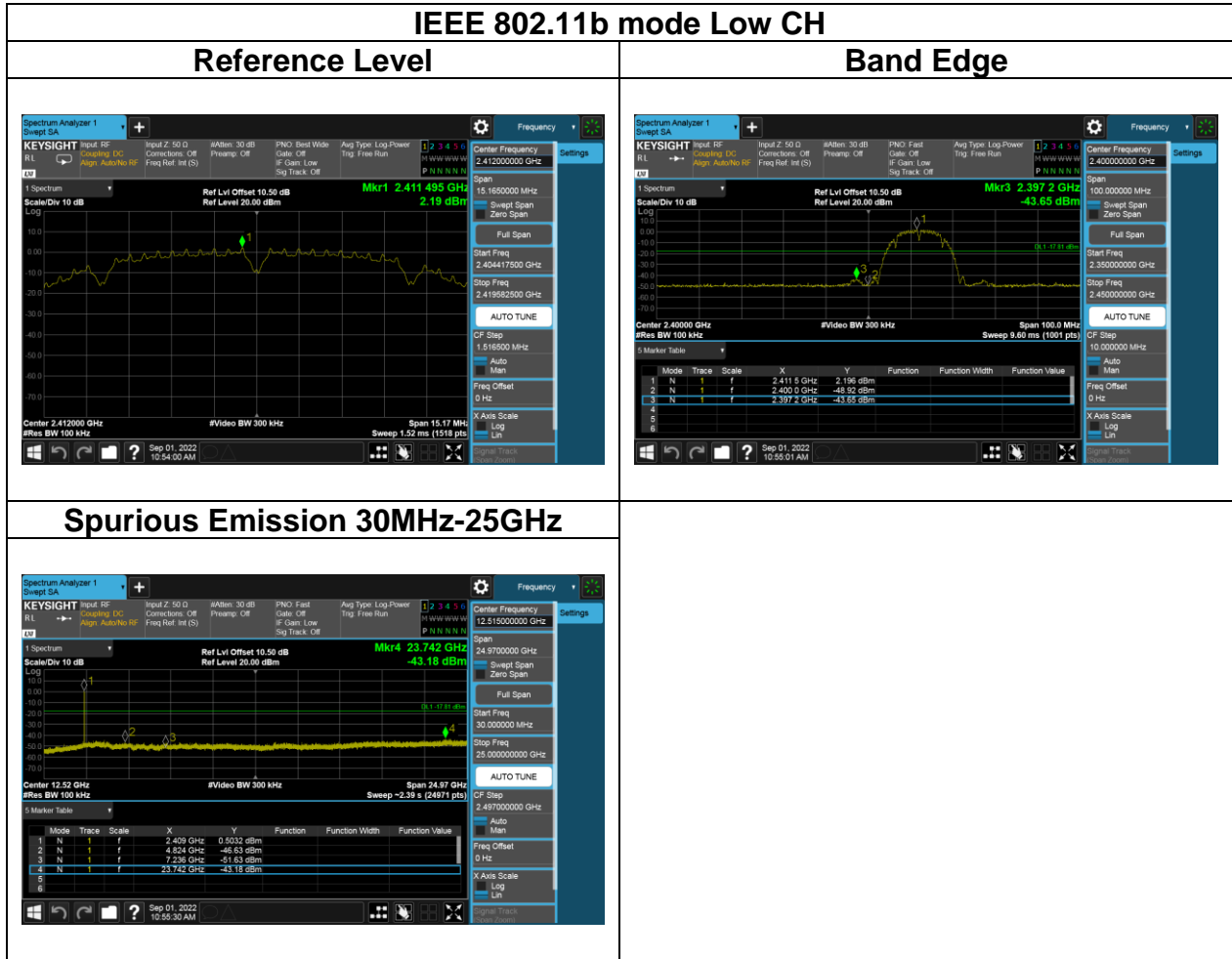



Report No.: TMWK2210004067KR

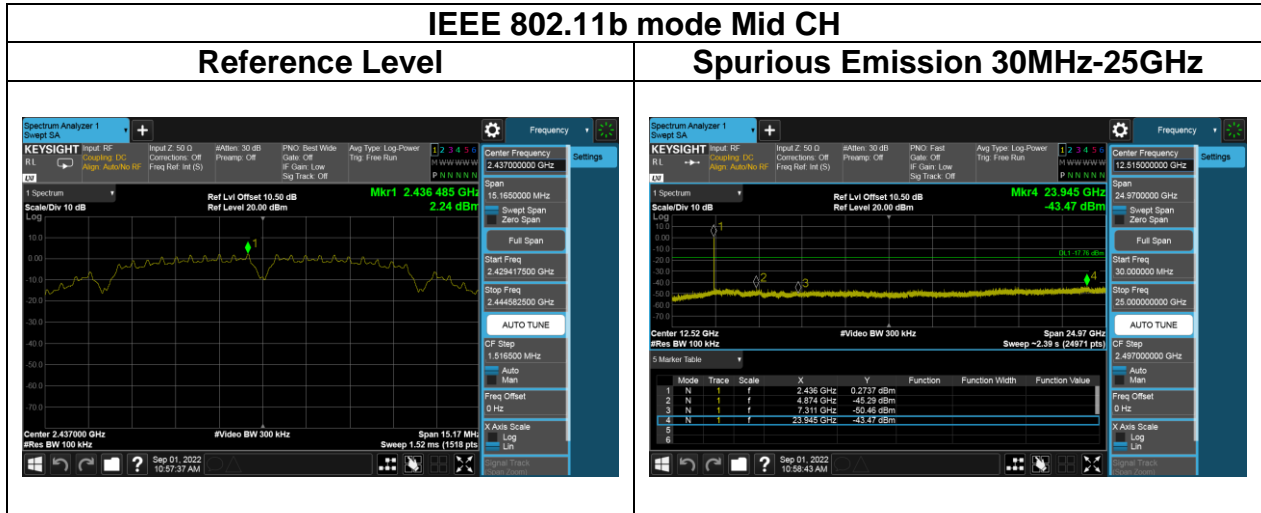

Report No.: TMWK2210004067KR

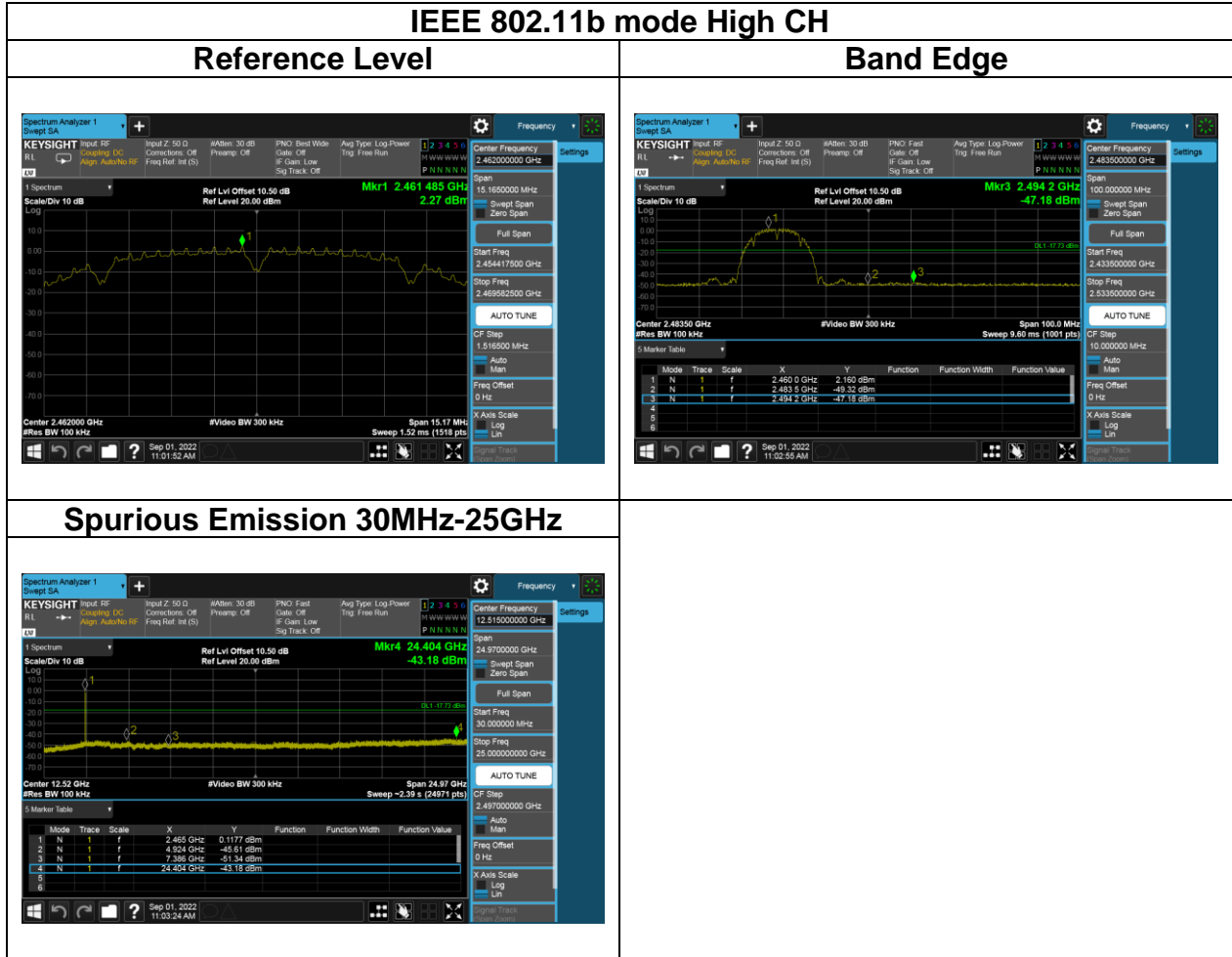

Report No.: TMWK2210004067KR

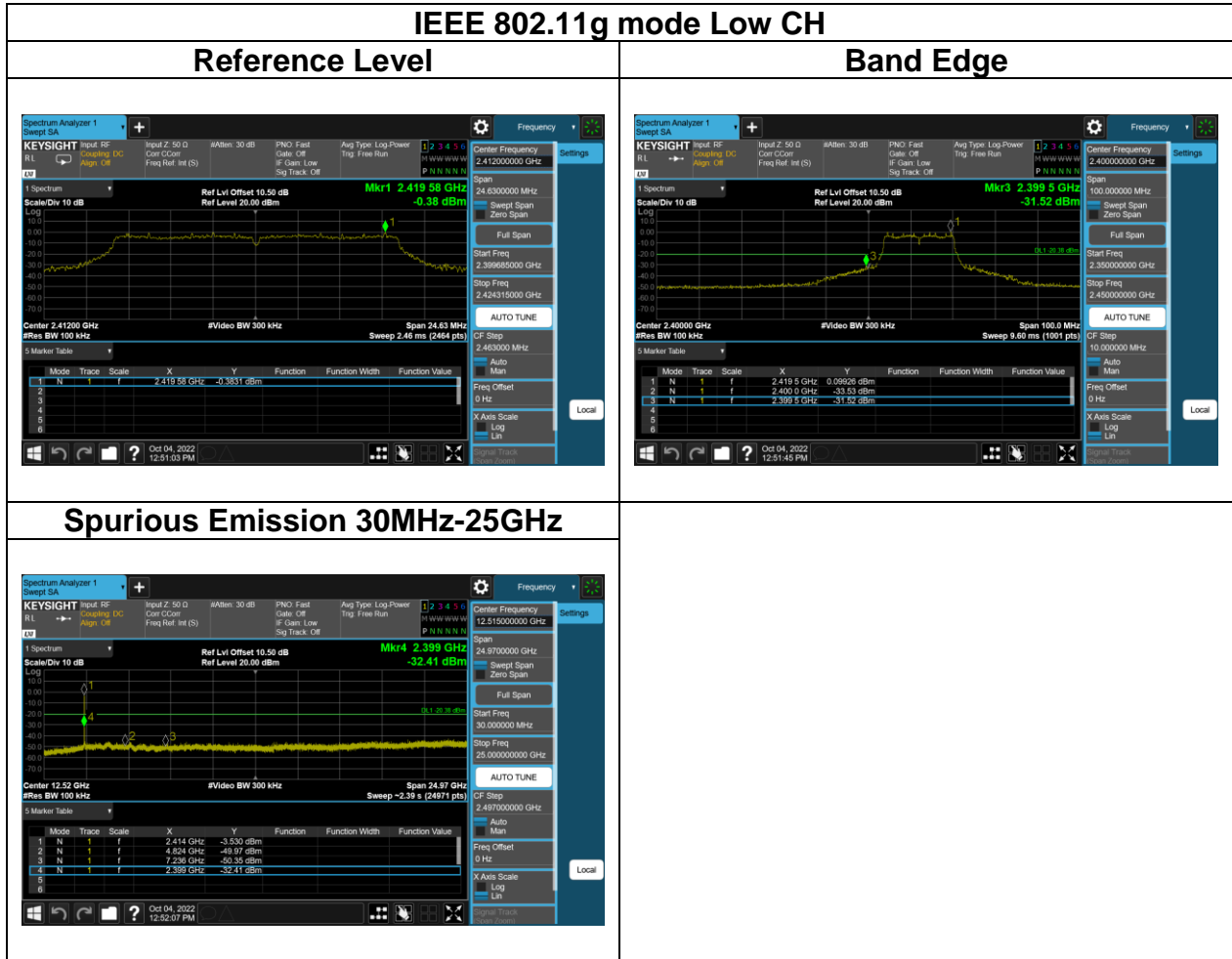

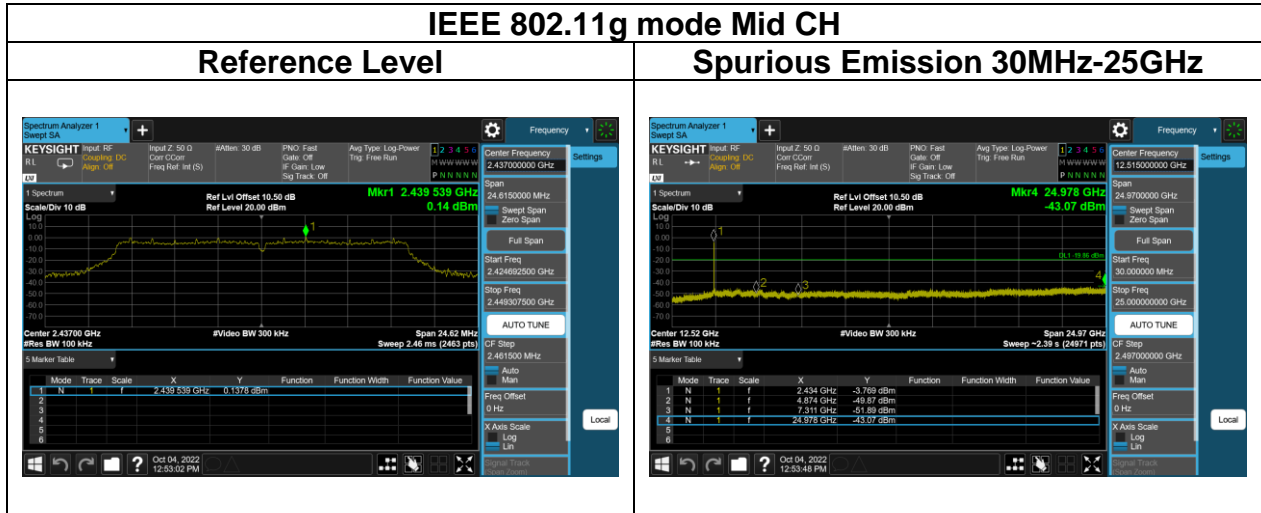



Report No.: TMWK2210004067KR

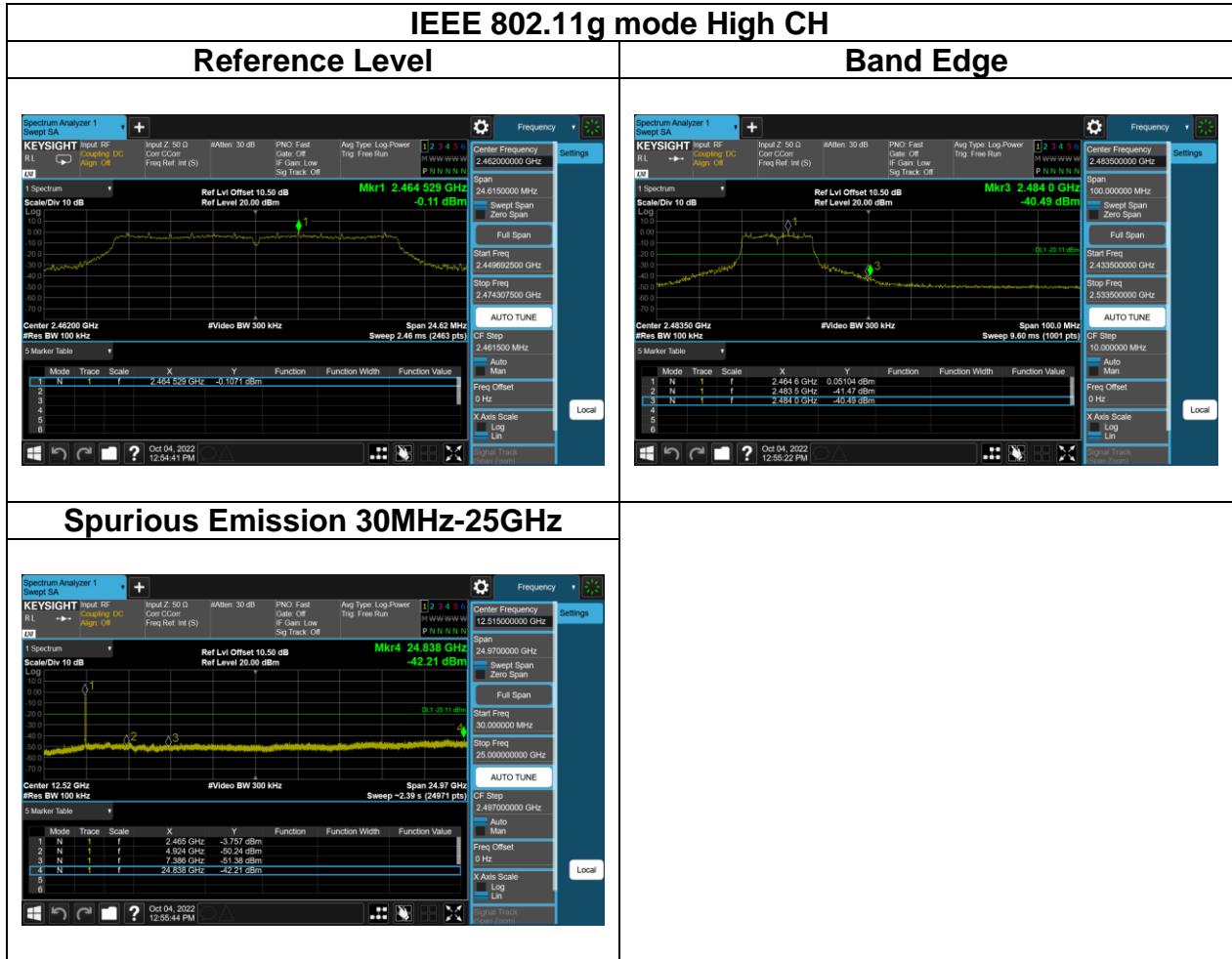

Report No.: TMWK2210004067KR

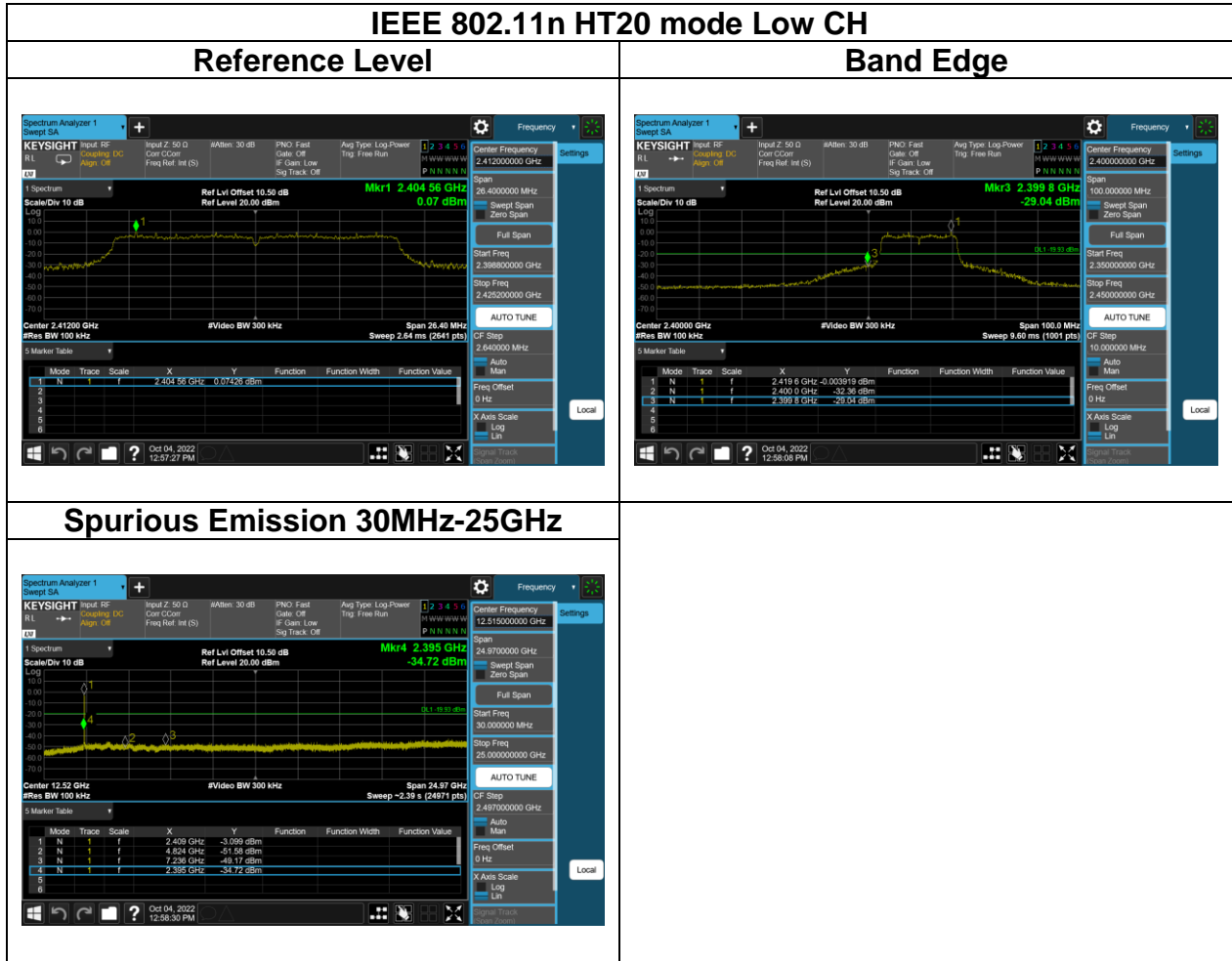

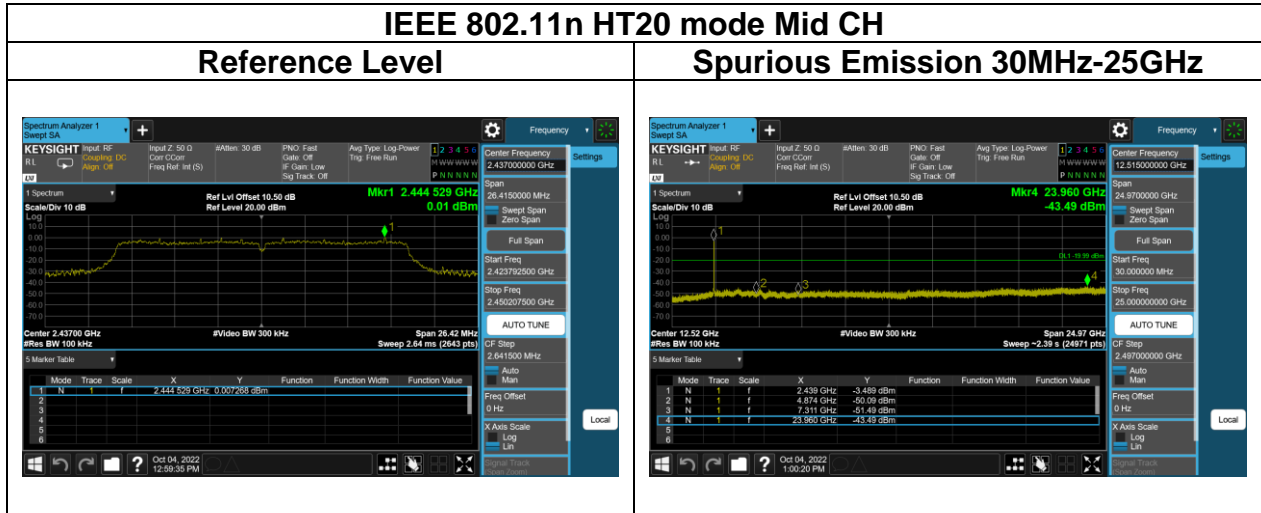



Report No.: TMWK2210004067KR

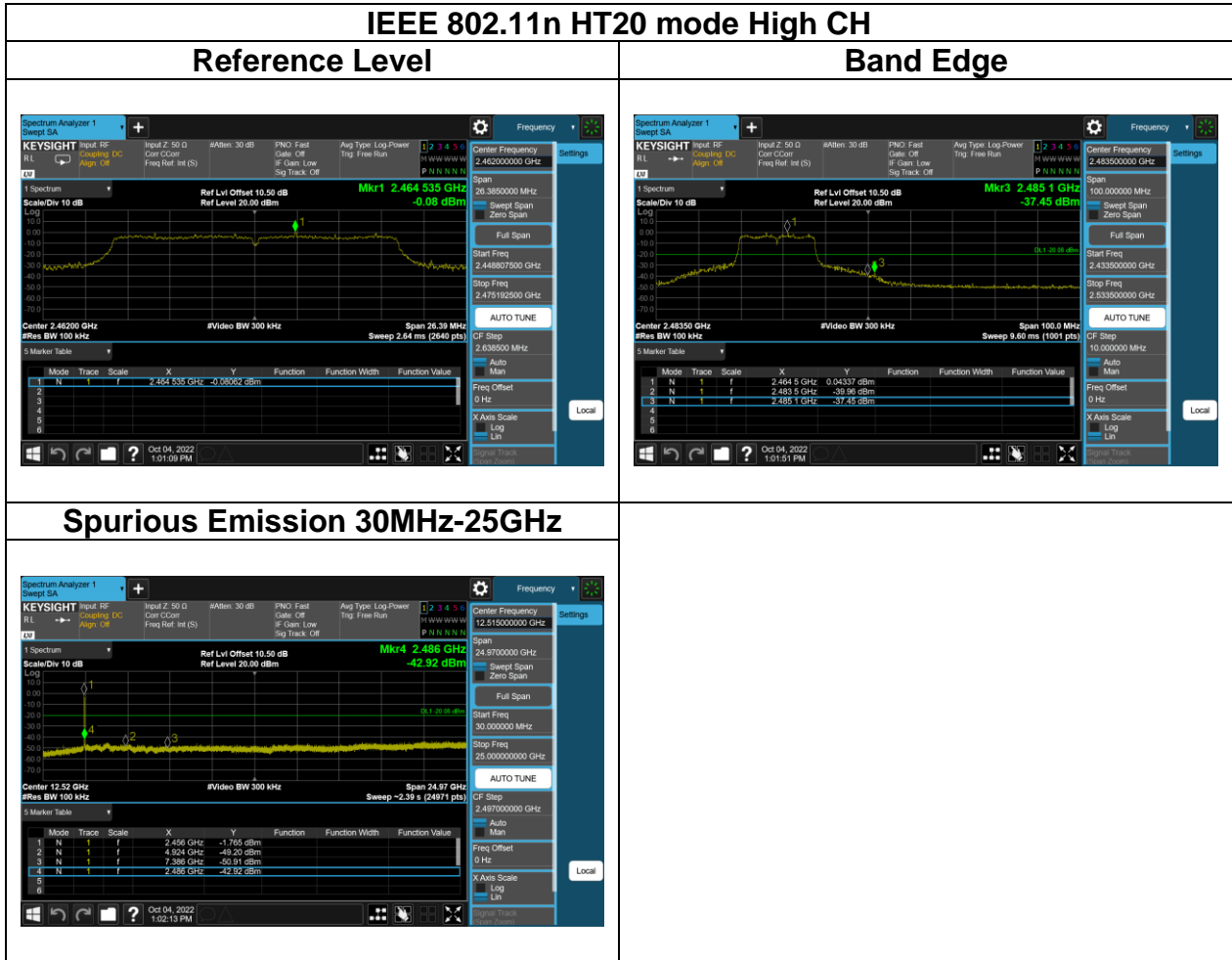

4.6 RADIATION BANDEGE AND SPURIOUS EMISSION

4.6.1 Test Limit

FCC according to §15.247(d), §15.209 and §15.205,

In any 100 kHz bandwidth outside the authorized frequency band, all harmonic and spurious must be least 20 dB below the highest emission level with the authorized frequency band. Radiation emission which fall in the restricted bands must also follow the FCC section 15.209 as below limit in table.

Below 30 MHz

Frequency	Field Strength (microvolts/m)	Magnetic H-Field (microamperes/m)	Measurement Distance (metres)
9-490 kHz	2,400/F (F in kHz)	2,400/F (F in kHz)	300
490-1,705 kHz	24,000/F (F in kHz)	24,000/F (F in kHz)	30
1.705-30 MHz	30	N/A	30

Above 30 MHz

Frequency	Field Strength (microvolts/m)	Measurement Distance (metres)
30-88	100	3
88-216	150	3
216-960	200	3
Above 960	500	3

Report No.: TMWK2210004067KR

4.6.2 Test Procedure

Test method Refer as ANSI C63.10:2013.

1. The EUT is placed on a turntable, Above 1 GHz is 1.5m and below 1 GHz is 0.8m above ground plane. The EUT Configured un accordance with ANSI C63.10: 2013, and the EUT set in a continuous mode.
2. The turntable shall be rotated for 360 degrees to determine the position of maximum emission level. And EUT is set 3m away from the receiving antenna, which is scanned from 1m to 4m above the ground plane to find out the highest emissions. Measurement are made polarized in both the vertical and the horizontal positions with antenna.
3. Span shall wide enough to full capture the emission measured. The SA from 9kHz to 26.5GHz set to the low, Mid and High channels with the EUT transmit.

Note: No emission found between lowest internal used/generated frequency to 30MHz (9KHz~30MHz)

Remark:

Although these tests were performed other than open area test site, adequate comparison measurements were confirmed against 30 m open are test site. Therefore sufficient tests were made to demonstrate that the alternative site produces results that correlate with the ones of tests made in an open field based on KDB 414788.

4. The SA setting following :

- (1) Below 1G : RBW = 100kHz, VBW \geq 3 RBW, Sweep = Auto, Detector = Peak, Trace = Max hold.
- (2) Above 1G :
 - (2.1) For Peak measurement : RBW = 1MHz, VBW \geq 3 RBW, Sweep = Auto, Detector = Peak, Trace = Max hold.
 - (2.2) For Average measurement : RBW = 1MHz, VBW
 - 'If Duty Cycle \geq 98%, VBW=10Hz.
 - 'If Duty Cycle < 98%, VBW=1/T.

5. Data result :

Actual FS=Spectrum Reading Level + Factor

Margin=Actual FS- Limit

Report No.: TMWK2210004067KR

4.6.3 Test Setup

9kHz ~ 30MHz

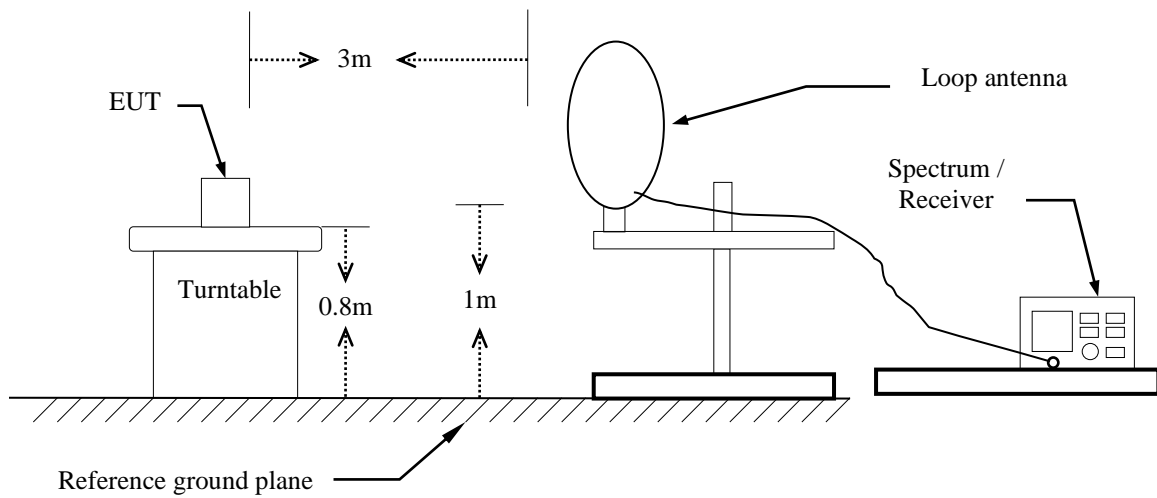

30MHz ~ 1GHz

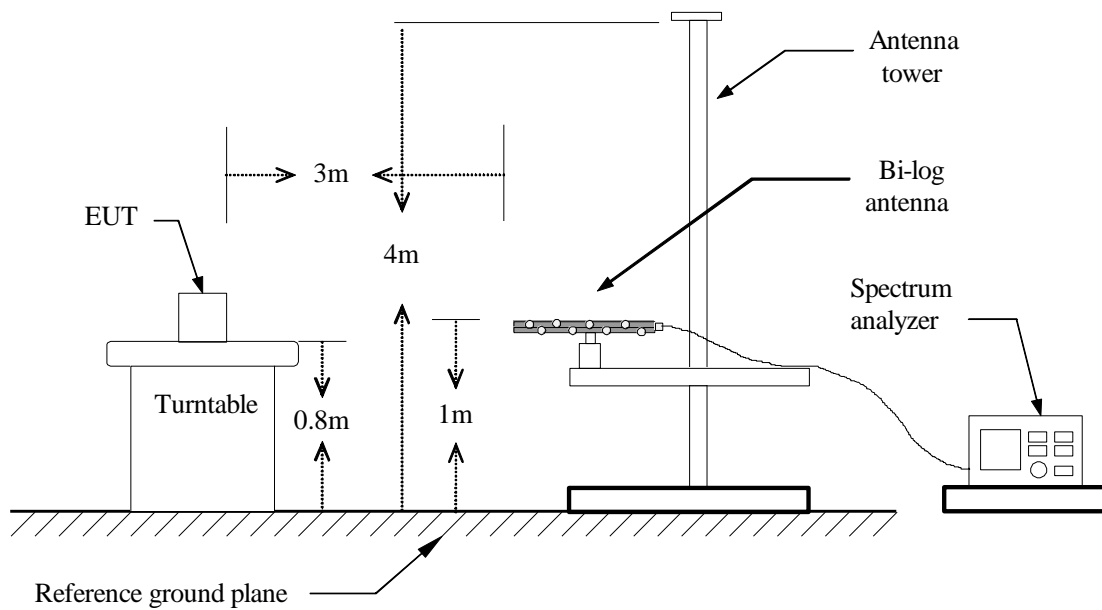

Above 1 GHz

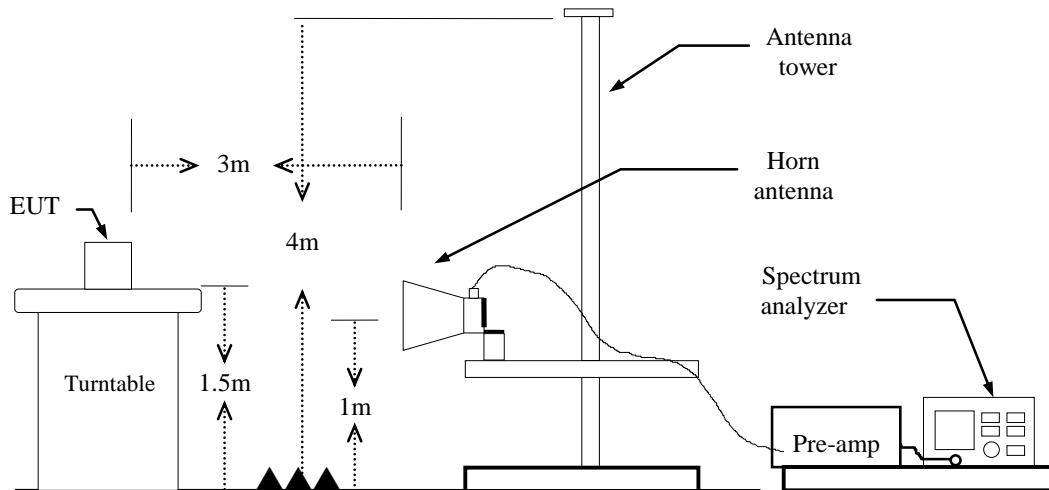

Report No.: TMWK2210004067KR

4.6.4 Test Result

Band Edge Test Data

Test Mode	IEEE 802.11b 2412 MHz	Temp/Hum	24.3(°C)/ 61%RH
Test Item	Band Edge	Test Date	September 8, 2022
Polarize	Vertical	Test Engineer	Tony Chao
Detector	Peak / Average		

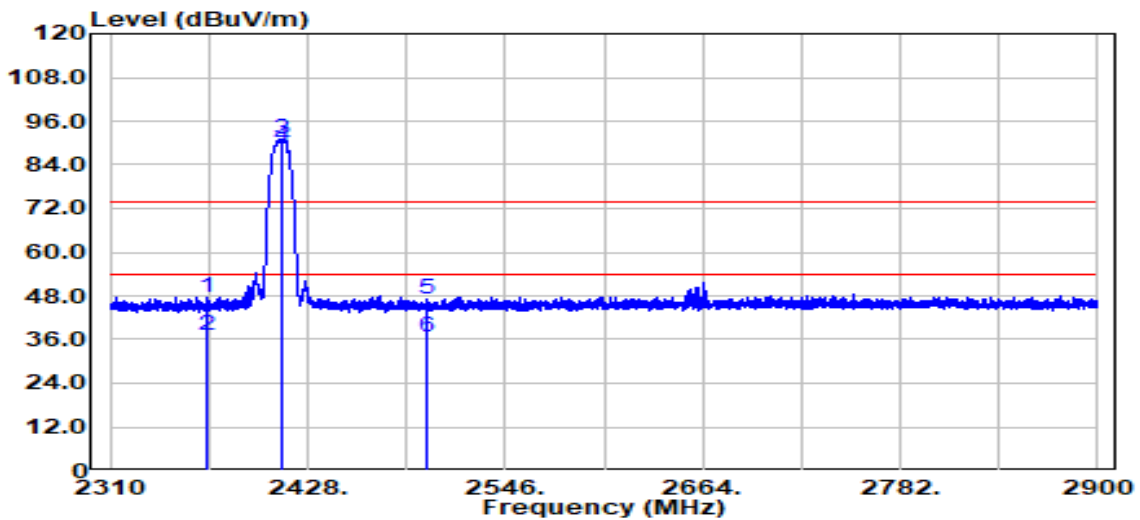

Frequency (MHz)	Detector Mode (PK/QP/AV)	Spectrum Reading Level (dBμV)	Factor (dB)	Actual FS (dBμV/m)	Limit @3m (dBμV/m)	Margin (dB)
2367.466	Peak	39.98	7.69	47.67	74.00	-26.33
2367.466	Average	29.42	7.69	37.11	54.00	-16.89
2412.000	Peak	83.24	7.86	91.09	--	--
2412.000	Average	81.41	7.86	89.27	--	--
2499.862	Peak	38.96	8.34	47.30	74.00	-26.70
2499.862	Average	28.43	8.34	36.77	54.00	-17.23

Report No.: TMWK2210004067KR

Test Mode	IEEE 802.11b 2412 MHz	Temp/Hum	24.3(°C)/ 61%RH
Test Item	Band Edge	Test Date	September 8, 2022
Polarize	Horizontal	Test Engineer	Tony Chao
Detector	Peak / Average		

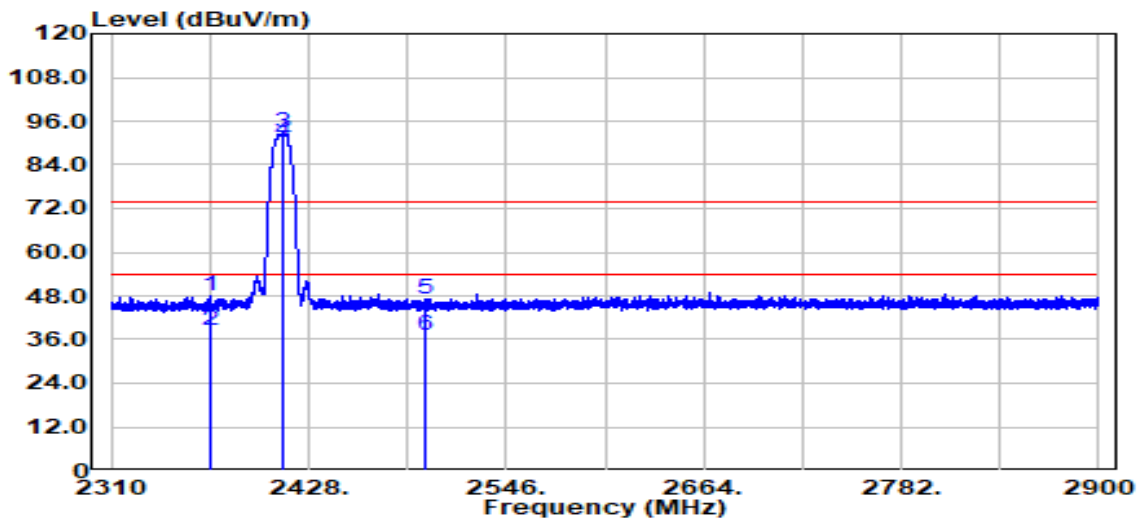

Frequency (MHz)	Detector Mode (PK/QP/AV)	Spectrum Reading Level (dBμV)	Factor (dB)	Actual FS (dBμV/m)	Limit @3m (dBμV/m)	Margin (dB)
2369.118	Peak	40.23	7.69	47.92	74.00	-26.08
2369.118	Average	30.77	7.69	38.47	54.00	-15.53
2412.000	Peak	84.76	7.86	92.62	--	--
2412.000	Average	82.93	7.86	90.79	--	--
2497.030	Peak	38.63	8.33	46.95	74.00	-27.05
2497.030	Average	28.71	8.33	37.03	54.00	-16.97

Test Mode	IEEE 802.11b 2462 MHz	Temp/Hum	24.3(°C)/ 61%RH
Test Item	Band Edge	Test Date	September 8, 2022
Polarize	Vertical	Test Engineer	Tony Chao
Detector	Peak / Average		

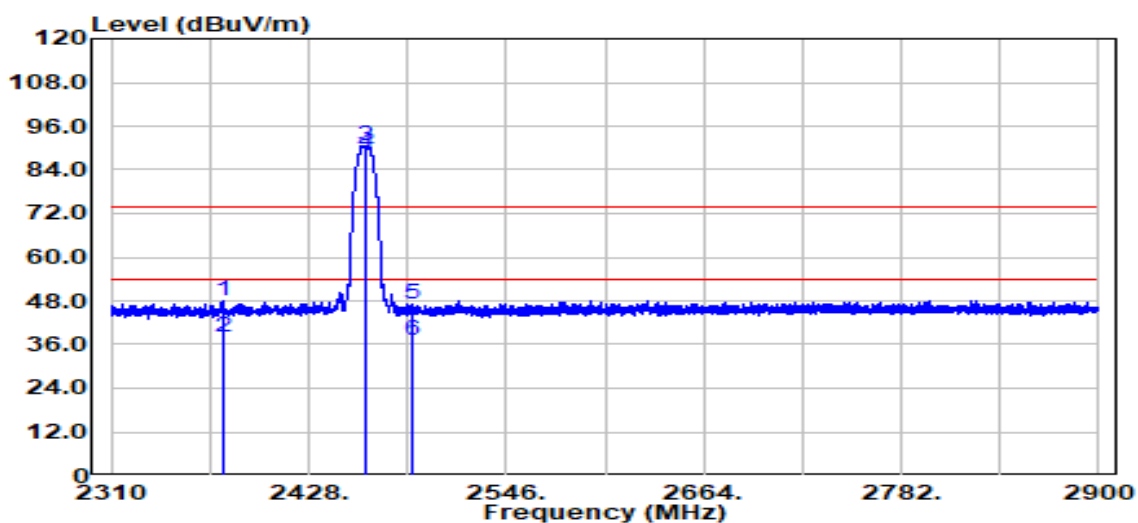

Frequency (MHz)	Detector Mode (PK/QP/AV)	Spectrum Reading Level (dBμV)	Factor (dB)	Actual FS (dBμV/m)	Limit @3m (dBμV/m)	Margin (dB)
2376.434	Peak	40.12	7.71	47.84	74.00	-26.16
2376.434	Average	30.20	7.71	37.92	54.00	-16.08
2462.000	Peak	82.55	8.16	90.70	--	--
2462.000	Average	80.78	8.16	88.94	--	--
2489.242	Peak	38.90	8.29	47.19	74.00	-26.81
2489.242	Average	28.85	8.29	37.13	54.00	-16.87

Report No.: TMWK2210004067KR

Test Mode	IEEE 802.11b 2462 MHz	Temp/Hum	24.3(°C)/ 61%RH
Test Item	Band Edge	Test Date	September 8, 2022
Polarize	Horizontal	Test Engineer	Tony Chao
Detector	Peak / Average		

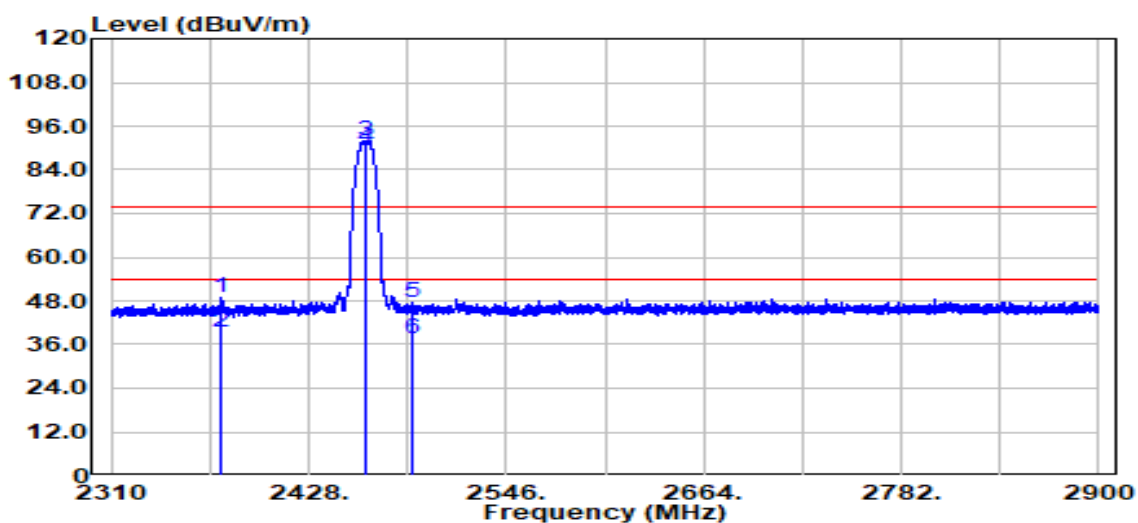

Frequency (MHz)	Detector Mode (PK/QP/AV)	Spectrum Reading Level (dBμV)	Factor (dB)	Actual FS (dBμV/m)	Limit @3m (dBμV/m)	Margin (dB)
2375.844	Peak	41.01	7.71	48.72	74.00	-25.28
2375.844	Average	31.81	7.71	39.52	54.00	-14.48
2462.000	Peak	83.74	8.16	91.90	--	--
2462.000	Average	81.89	8.16	90.05	--	--
2490.186	Peak	39.11	8.29	47.41	74.00	-26.59
2490.186	Average	29.23	8.29	37.52	54.00	-16.48

Report No.: TMWK2210004067KR

Test Mode	IEEE 802.11g 2412 MHz	Temp/Hum	24.6(°C)/ 62%RH
Test Item	Band Edge	Test Date	October 3, 2022
Polarize	Vertical	Test Engineer	Ray Li
Detector	Peak / Average		

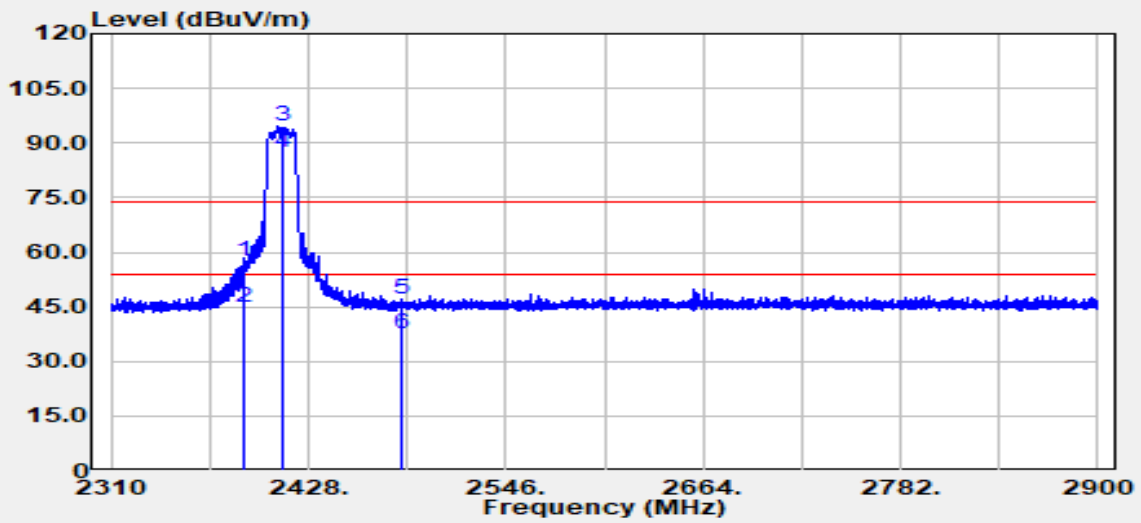

Frequency (MHz)	Detector Mode (PK/QP/AV)	Spectrum Reading Level (dBμV)	Factor (dB)	Actual FS (dBμV/m)	Limit @3m (dBμV/m)	Margin (dB)
2389.886	Peak	49.79	7.75	57.54	74.00	-16.46
2389.886	Average	37.14	7.75	44.89	54.00	-9.11
2412.000	Peak	86.61	7.86	94.46	--	--
2412.000	Average	79.40	7.86	87.25	--	--
2484.050	Peak	38.96	8.26	47.22	74.00	-26.78
2484.050	Average	29.25	8.26	37.52	54.00	-16.48

Report No.: TMWK2210004067KR

Test Mode	IEEE 802.11g 2412 MHz	Temp/Hum	24.6(°C)/ 62%RH
Test Item	Band Edge	Test Date	October 3, 2022
Polarize	Horizontal	Test Engineer	Ray Li
Detector	Peak / Average		

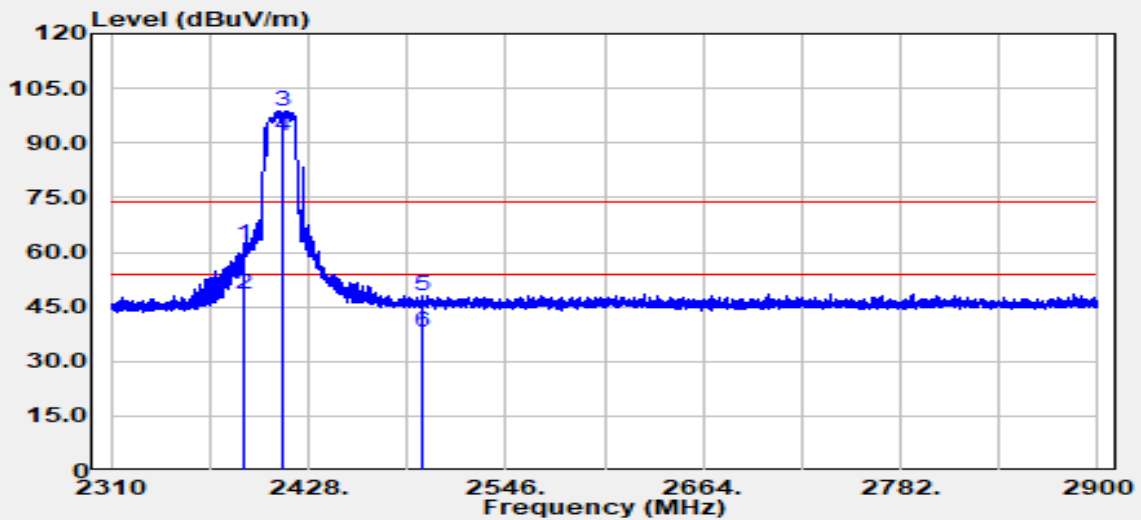

Frequency (MHz)	Detector Mode (PK/QP/AV)	Spectrum Reading Level (dBμV)	Factor (dB)	Actual FS (dBμV/m)	Limit @3m (dBμV/m)	Margin (dB)
2389.886	Peak	54.35	7.75	62.10	74.00	-11.90
2389.886	Average	40.89	7.75	48.64	54.00	-5.36
2412.000	Peak	91.04	7.86	98.90	--	--
2412.000	Average	83.94	7.86	91.80	--	--
2496.322	Peak	39.65	8.32	47.97	74.00	-26.03
2496.322	Average	29.76	8.32	38.08	54.00	-15.92

Report No.: TMWK2210004067KR

Test Mode	IEEE 802.11g 2462 MHz	Temp/Hum	24.6(°C)/ 62%RH
Test Item	Band Edge	Test Date	October 3, 2022
Polarize	Vertical	Test Engineer	Ray Li
Detector	Peak / Average		

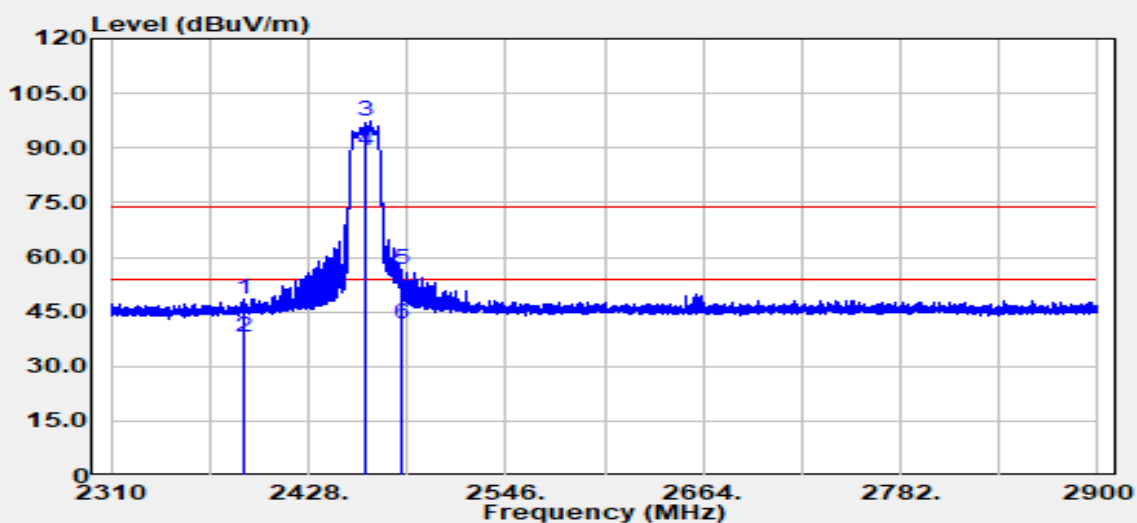

Frequency (MHz)	Detector Mode (PK/QP/AV)	Spectrum Reading Level (dBUV)	Factor (dB)	Actual FS (dBUV/m)	Limit @3m (dBUV/m)	Margin (dB)
2389.414	Peak	40.70	7.75	48.45	74.00	-25.55
2389.414	Average	30.32	7.75	38.07	54.00	-15.93
2462.000	Peak	88.99	8.16	97.15	--	--
2462.000	Average	81.08	8.16	89.23	--	--
2483.696	Peak	48.52	8.26	56.78	74.00	-17.22
2483.696	Average	33.39	8.26	41.65	54.00	-12.35

Test Mode	IEEE 802.11g 2462 MHz	Temp/Hum	24.6(°C)/ 62%RH
Test Item	Band Edge	Test Date	October 3, 2022
Polarize	Horizontal	Test Engineer	Ray Li
Detector	Peak / Average		

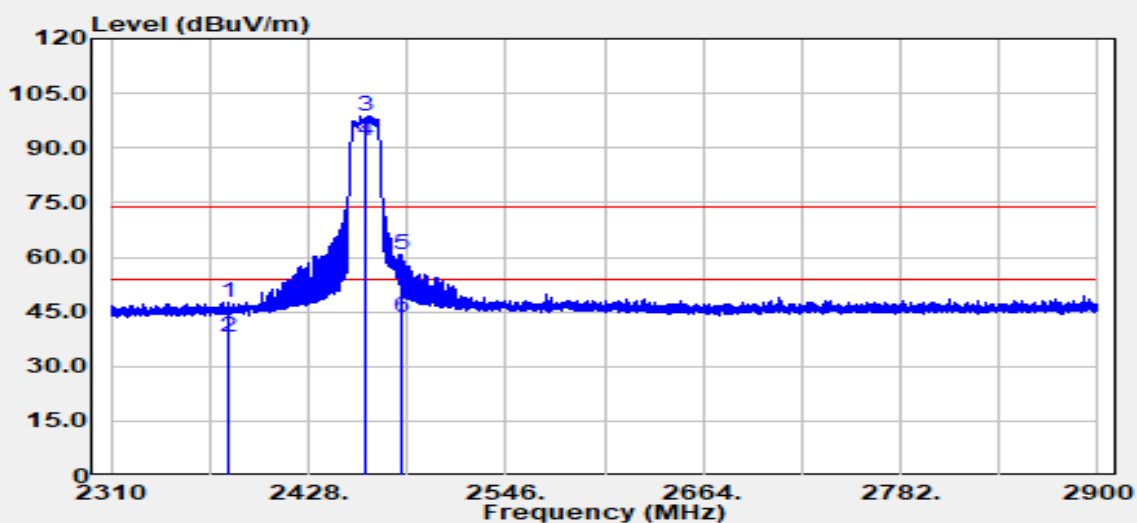

Frequency (MHz)	Detector Mode (PK/QP/AV)	Spectrum Reading Level (dBμV)	Factor (dB)	Actual FS (dBμV/m)	Limit @3m (dBμV/m)	Margin (dB)
2379.620	Peak	39.90	7.72	47.63	74.00	-26.37
2379.620	Average	30.16	7.72	37.89	54.00	-16.11
2462.000	Peak	90.74	8.16	98.90	--	--
2462.000	Average	83.61	8.16	91.77	--	--
2483.814	Peak	52.55	8.26	60.82	74.00	-13.18
2483.814	Average	35.33	8.26	43.59	54.00	-10.41

Report No.: TMWK2210004067KR

Test Mode	IEEE 802.11n HT20 2412 MHz	Temp/Hum	24.6(°C)/ 62%RH
Test Item	Band Edge	Test Date	October 3, 2022
Polarize	Vertical	Test Engineer	Ray Li
Detector	Peak / Average		

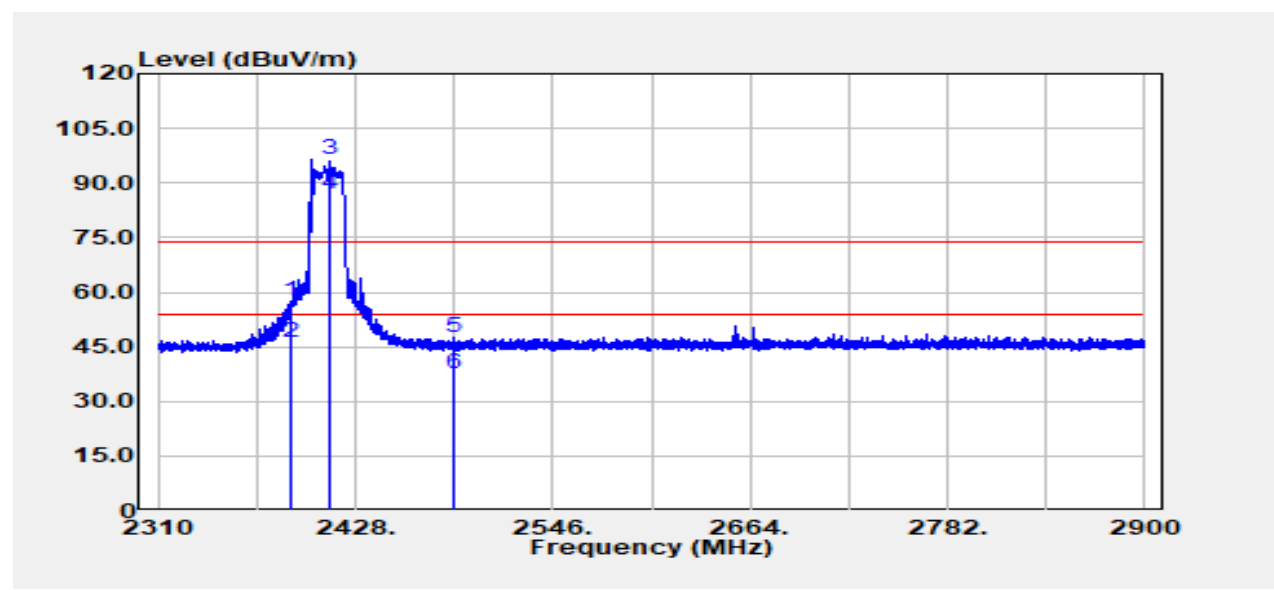

Frequency (MHz)	Detector Mode (PK/QP/AV)	Spectrum Reading Level (dBμV)	Factor (dB)	Actual FS (dBμV/m)	Limit @3m (dBμV/m)	Margin (dB)
2389.414	Peak	49.91	7.75	57.66	74.00	-16.34
2389.414	Average	38.30	7.75	46.05	54.00	-7.95
2412.000	Peak	88.67	7.86	96.53	--	--
2412.000	Average	79.24	7.86	87.10	--	--
2486.528	Peak	39.25	8.28	47.53	74.00	-26.47
2486.528	Average	29.36	8.28	37.63	54.00	-16.37

Report No.: TMWK2210004067KR

Test Mode	IEEE 802.11n HT20 2412 MHz	Temp/Hum	24.6(°C)/ 62%RH
Test Item	Band Edge	Test Date	October 3, 2022
Polarize	Horizontal	Test Engineer	Ray Li
Detector	Peak / Average		

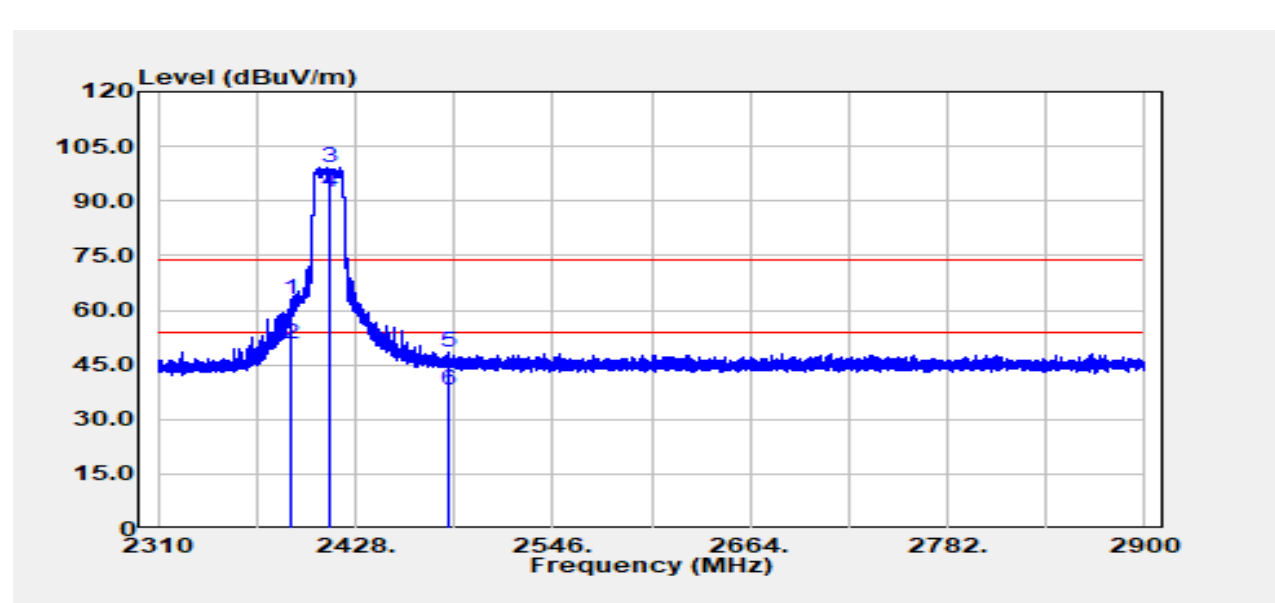

Frequency (MHz)	Detector Mode (PK/QP/AV)	Spectrum Reading Level (dBμV)	Factor (dB)	Actual FS (dBμV/m)	Limit @3m (dBμV/m)	Margin (dB)
2389.449	Peak	55.40	7.75	63.15	74.00	-10.85
2389.449	Average	43.16	7.75	50.91	54.00	-3.09
2412.000	Peak	91.50	7.86	99.35	--	--
2412.000	Average	84.36	7.86	92.22	--	--
2484.169	Peak	39.97	8.26	48.23	74.00	-25.77
2484.169	Average	29.99	8.26	38.25	54.00	-15.75

Report No.: TMWK2210004067KR

Test Mode	IEEE 802.11n HT20 2462 MHz	Temp/Hum	24.6(°C)/ 62%RH
Test Item	Band Edge	Test Date	October 3, 2022
Polarize	Vertical	Test Engineer	Ray Li
Detector	Peak / Average		

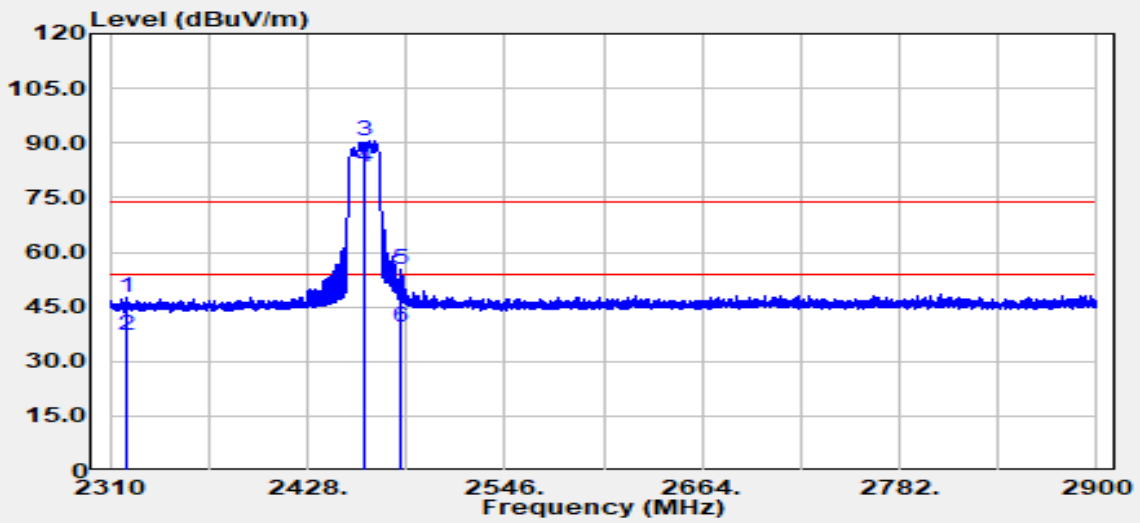

Frequency (MHz)	Detector Mode (PK/QP/AV)	Spectrum Reading Level (dBμV)	Factor (dB)	Actual FS (dBμV/m)	Limit @3m (dBμV/m)	Margin (dB)
2319.440	Peak	39.96	7.59	47.55	74.00	-26.45
2319.440	Average	29.58	7.59	37.17	54.00	-16.83
2462.000	Peak	82.41	8.16	90.56	--	--
2462.000	Average	75.10	8.16	83.26	--	--
2483.932	Peak	47.09	8.26	55.36	74.00	-18.64
2483.932	Average	30.94	8.26	39.21	54.00	-14.79

Report No.: TMWK2210004067KR

Test Mode	IEEE 802.11n HT20 2462 MHz	Temp/Hum	24.6(°C)/ 62%RH
Test Item	Band Edge	Test Date	October 3, 2022
Polarize	Horizontal	Test Engineer	Ray Li
Detector	Peak / Average		

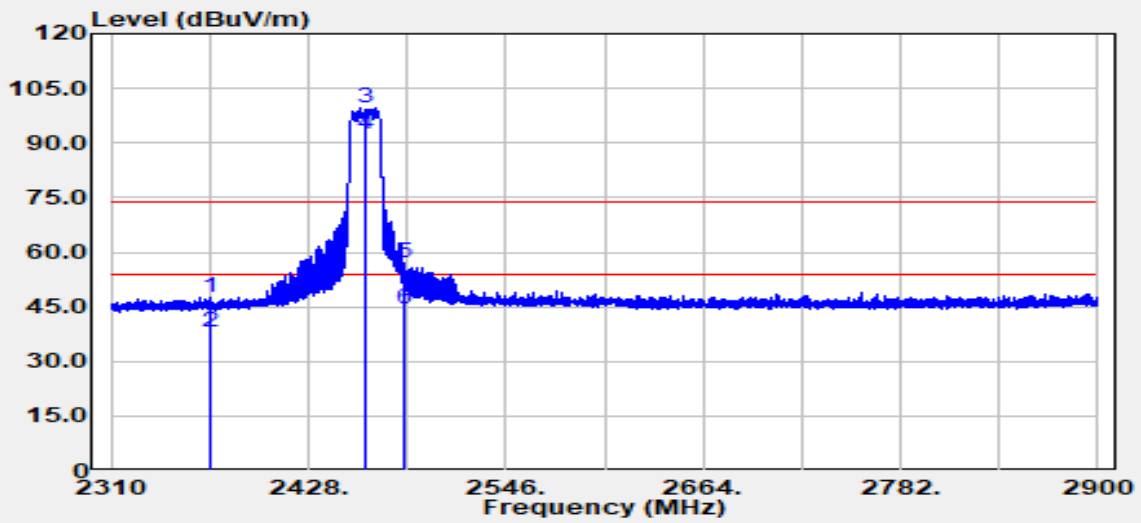

Frequency (MHz)	Detector Mode (PK/QP/AV)	Spectrum Reading Level (dBμV)	Factor (dB)	Actual FS (dBμV/m)	Limit @3m (dBμV/m)	Margin (dB)
2369.354	Peak	39.85	7.69	47.55	74.00	-26.45
2369.354	Average	30.31	7.69	38.00	54.00	-16.00
2462.000	Peak	91.59	8.16	99.75	--	--
2462.000	Average	84.05	8.16	92.21	--	--
2485.230	Peak	48.62	8.27	56.89	74.00	-17.11
2485.230	Average	35.91	8.27	44.18	54.00	-9.82

Below 1G Test Data

Test Mode	IEEE 802.11b 2437 MHz	Temp/Hum	24.6(°C)/ 62%RH
Test Item	30MHz-1GHz	Test Date	October 3, 2022
Polarize	Vertical	Test Engineer	Tony Chao
Detector	Peak	EUT	Mode 4: 7.8" Color Digital Note Pad

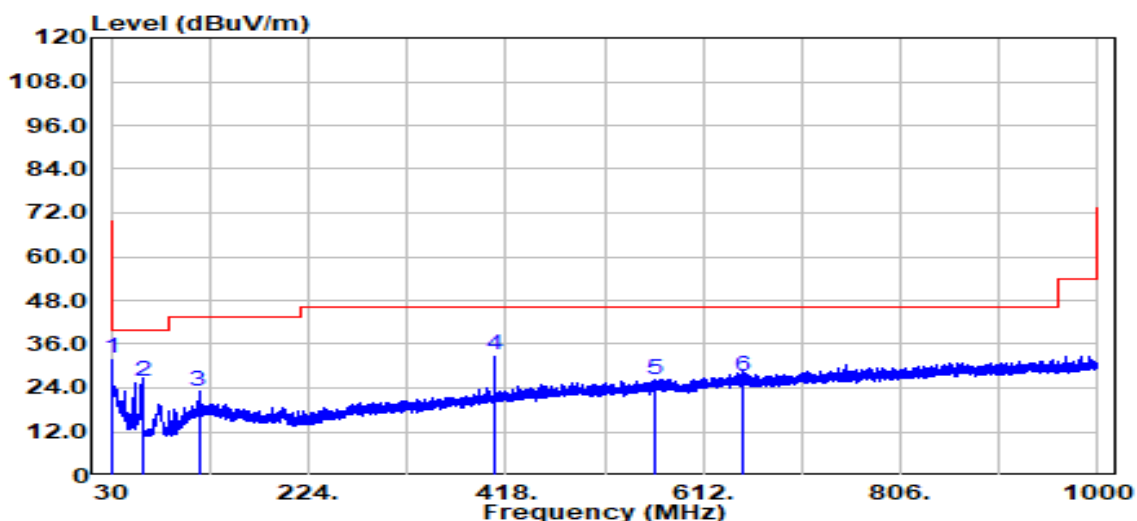

Frequency (MHz)	Detector Mode (PK/QP/AV)	Spectrum Reading Level (dB μ V)	Factor (dB)	Actual FS (dB μ V/m)	Limit @3m (dB μ V/m)	Margin (dB)
30.000	Peak	35.50	-3.22	32.28	40.00	-7.72
62.495	Peak	41.84	-16.10	25.74	40.00	-14.26
116.088	Peak	32.84	-9.92	22.92	43.50	-20.58
408.058	Peak	38.80	-5.71	33.09	46.00	-12.91
563.864	Peak	29.08	-2.60	26.47	46.00	-19.53
650.194	Peak	28.26	-0.94	27.32	46.00	-18.68

Note: No emission found between lowest internal used/generated frequency to 30MHz(9KHz~30MHz)

Test Mode	IEEE 802.11b 2437 MHz	Temp/Hum	24.6(°C)/ 62%RH
Test Item	30MHz-1GHz	Test Date	October 3, 2022
Polarize	Horizontal	Test Engineer	Tony Chao
Detector	Peak	EUT	Mode 4: 7.8" Color Digital Note Pad

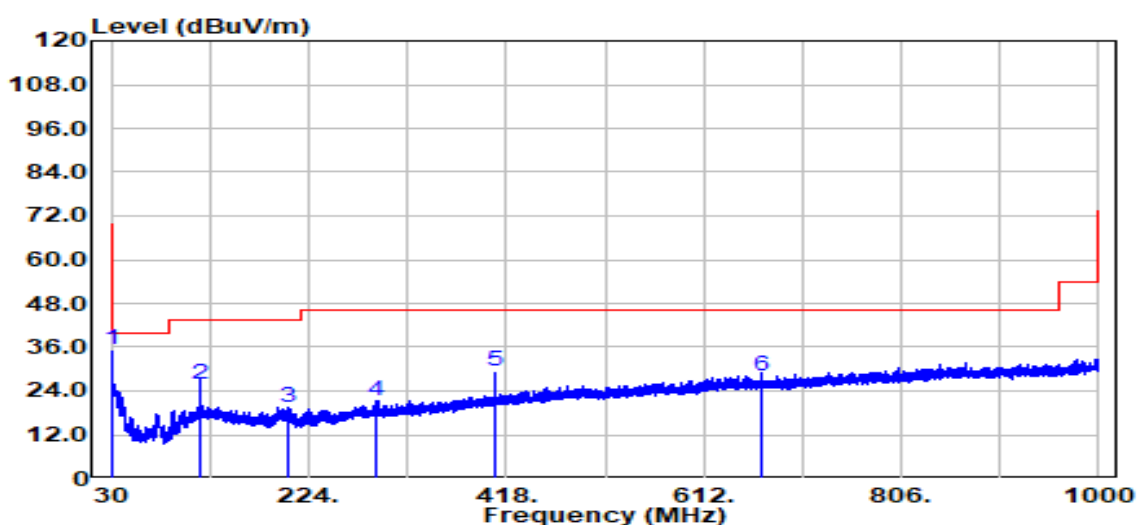

Frequency (MHz)	Detector Mode (PK/QP/AV)	Spectrum Reading Level (dBμV)	Factor (dB)	Actual FS (dBμV/m)	Limit @3m (dBμV/m)	Margin (dB)
30.000	Peak	38.54	-3.22	35.32	40.00	-4.68
116.573	Peak	35.45	-9.72	25.73	43.50	-17.77
204.236	Peak	31.32	-11.76	19.57	43.50	-23.93
291.051	Peak	30.34	-8.97	21.37	46.00	-24.63
408.058	Peak	35.34	-5.71	29.64	46.00	-16.36
667.775	Peak	28.87	-0.89	27.99	46.00	-18.01

Note: No emission found between lowest internal used/generated frequency to 30MHz(9KHz~30MHz)

Report No.: TMWK2210004067KR

Test Mode	IEEE 802.11b 2437 MHz	Temp/Hum	24.6(°C)/ 62%RH
Test Item	30MHz-1GHz	Test Date	October 3, 2022
Polarize	Vertical	Test Engineer	Tony Chao
Detector	Peak	EUT	Mode 1: 7.8" Digital Reader

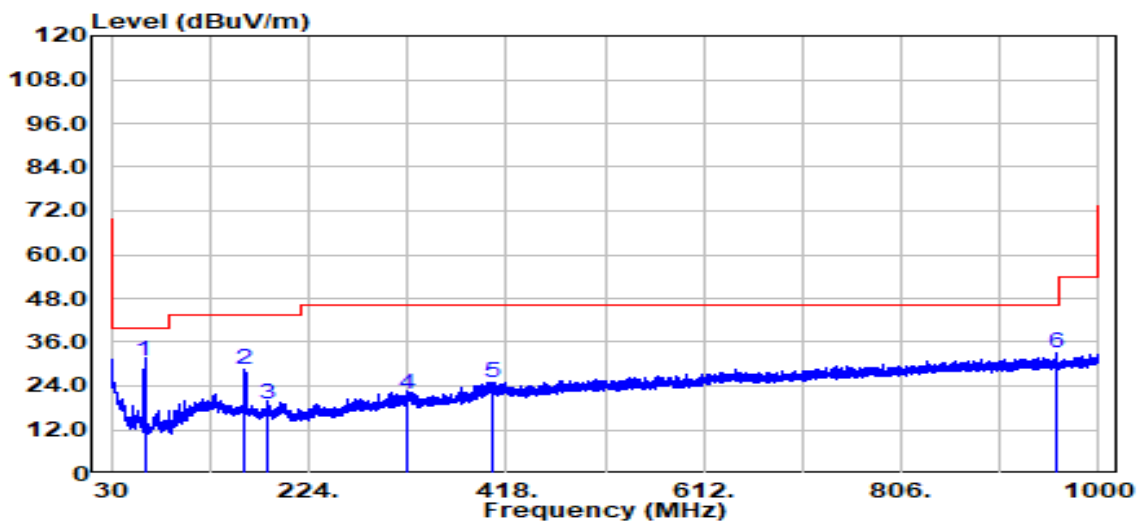

Frequency (MHz)	Detector Mode (PK/QP/AV)	Spectrum Reading Level (dBμV)	Factor (dB)	Actual FS (dBμV/m)	Limit @3m (dBμV/m)	Margin (dB)
62.738	Peak	46.87	-16.07	30.80	40.00	-9.20
161.678	Peak	39.32	-10.88	28.44	43.50	-15.06
184.351	Peak	30.84	-11.75	19.09	43.50	-24.41
321.606	Peak	30.24	-8.40	21.84	46.00	-24.16
403.450	Peak	30.85	-5.86	24.99	46.00	-21.01
958.048	Peak	29.64	3.25	32.88	46.00	-13.12

Note: No emission found between lowest internal used/generated frequency to 30MHz(9KHz~30MHz)

Test Mode	IEEE 802.11b 2437 MHz	Temp/Hum	24.6(°C)/ 62%RH
Test Item	30MHz-1GHz	Test Date	October 3, 2022
Polarize	Horizontal	Test Engineer	Tony Chao
Detector	Peak	EUT	Mode 1: 7.8" Digital Reader

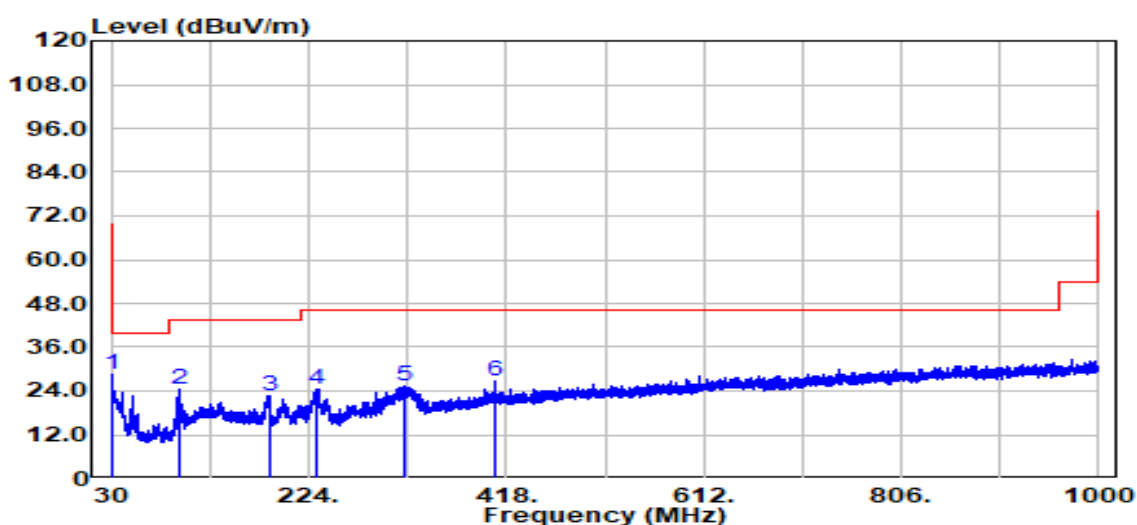

Frequency (MHz)	Detector Mode (PK/QP/AV)	Spectrum Reading Level (dBμV)	Factor (dB)	Actual FS (dBμV/m)	Limit @3m (dBμV/m)	Margin (dB)
30.000	Peak	31.80	-3.22	28.58	40.00	-11.42
97.658	Peak	38.15	-13.76	24.39	43.50	-19.11
184.958	Peak	34.28	-11.68	22.60	43.50	-20.90
232.124	Peak	35.93	-11.31	24.62	46.00	-21.38
318.818	Peak	33.62	-8.45	25.17	46.00	-20.83
407.936	Peak	32.44	-5.71	26.73	46.00	-19.27

Note: No emission found between lowest internal used/generated frequency to 30MHz(9KHz~30MHz)

Report No.: TMWK2210004067KR

Test Mode	IEEE 802.11b 2437 MHz	Temp/Hum	24.6(°C)/ 62%RH
Test Item	30MHz-1GHz	Test Date	October 3, 2022
Polarize	Vertical	Test Engineer	Tony Chao
Detector	Peak	EUT	Mode 2: 7.8" Digital Note Pad

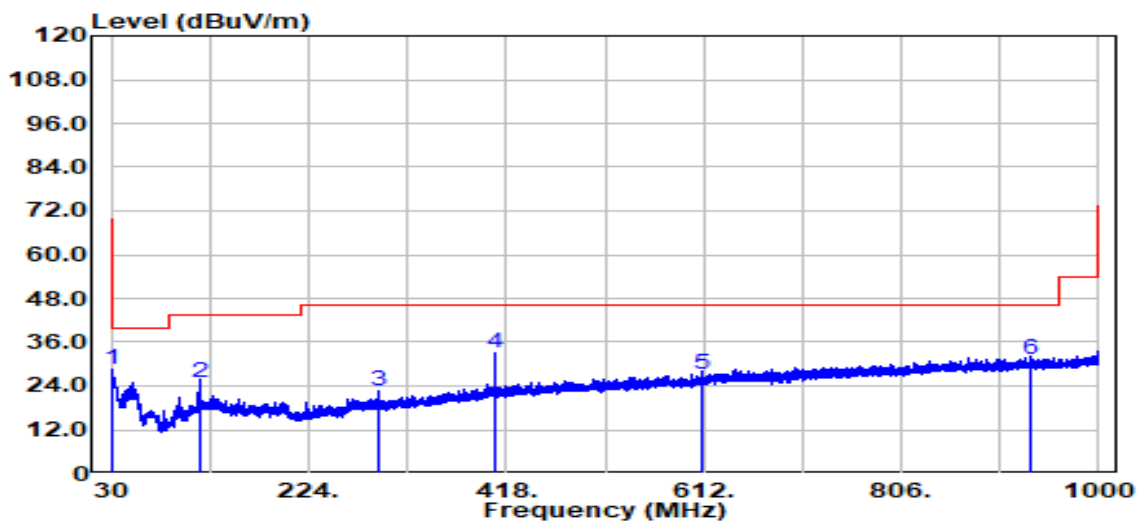

Frequency (MHz)	Detector Mode (PK/QP/AV)	Spectrum Reading Level (dB μ V)	Factor (dB)	Actual FS (dB μ V/m)	Limit @3m (dB μ V/m)	Margin (dB)
30.000	Peak	31.91	-3.22	28.69	40.00	-11.31
116.330	Peak	34.53	-9.82	24.71	43.50	-18.79
291.779	Peak	31.80	-8.96	22.84	46.00	-23.16
408.058	Peak	38.74	-5.71	33.03	46.00	-12.97
609.939	Peak	29.23	-1.98	27.25	46.00	-18.75
932.343	Peak	27.92	3.13	31.05	46.00	-14.95

Note: No emission found between lowest internal used/generated frequency to 30MHz(9KHz~30MHz)

Report No.: TMWK2210004067KR

Test Mode	IEEE 802.11b 2437 MHz	Temp/Hum	24.6(°C)/ 62%RH
Test Item	30MHz-1GHz	Test Date	October 3, 2022
Polarize	Horizontal	Test Engineer	Tony Chao
Detector	Peak	EUT	Mode 2: 7.8" Digital Note Pad

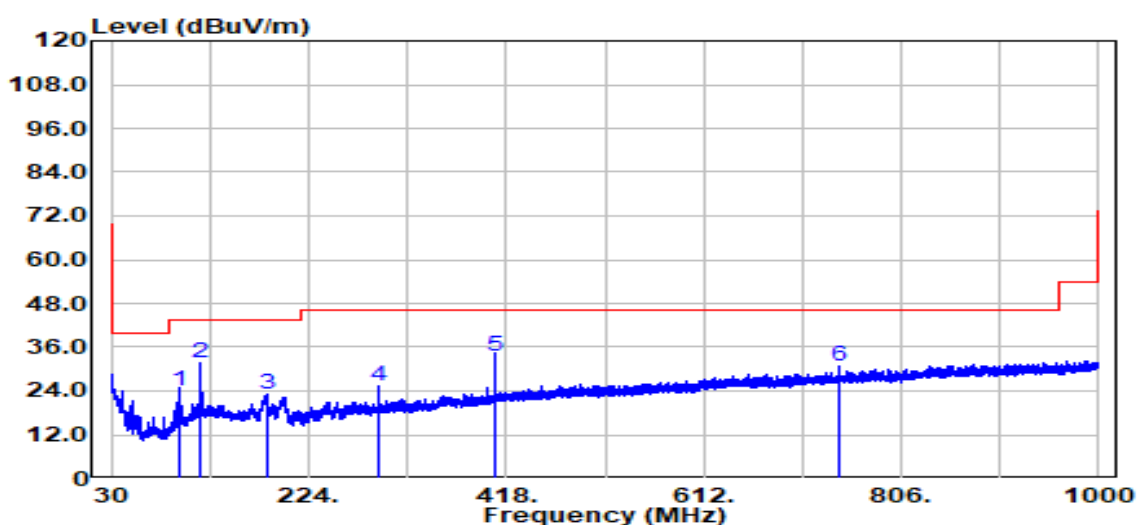

Frequency (MHz)	Detector Mode (PK/QP/AV)	Spectrum Reading Level (dBμV)	Factor (dB)	Actual FS (dBμV/m)	Limit @3m (dBμV/m)	Margin (dB)
96.203	Peak	38.10	-14.12	23.98	43.50	-19.52
116.573	Peak	41.28	-9.72	31.56	43.50	-11.94
182.411	Peak	34.78	-11.71	23.08	43.50	-20.42
291.779	Peak	34.27	-8.96	25.30	46.00	-20.70
408.058	Peak	39.20	-5.71	33.49	46.00	-12.51
744.163	Peak	30.22	0.35	30.57	46.00	-15.43

Note: No emission found between lowest internal used/generated frequency to 30MHz(9KHz~30MHz)

Report No.: TMWK2210004067KR

Test Mode	IEEE 802.11b 2437 MHz	Temp/Hum	24.6(°C)/ 62%RH
Test Item	30MHz-1GHz	Test Date	October 3, 2022
Polarize	Vertical	Test Engineer	Tony Chao
Detector	Peak	EUT	Mode 3: 7.8" Color Digital Reader

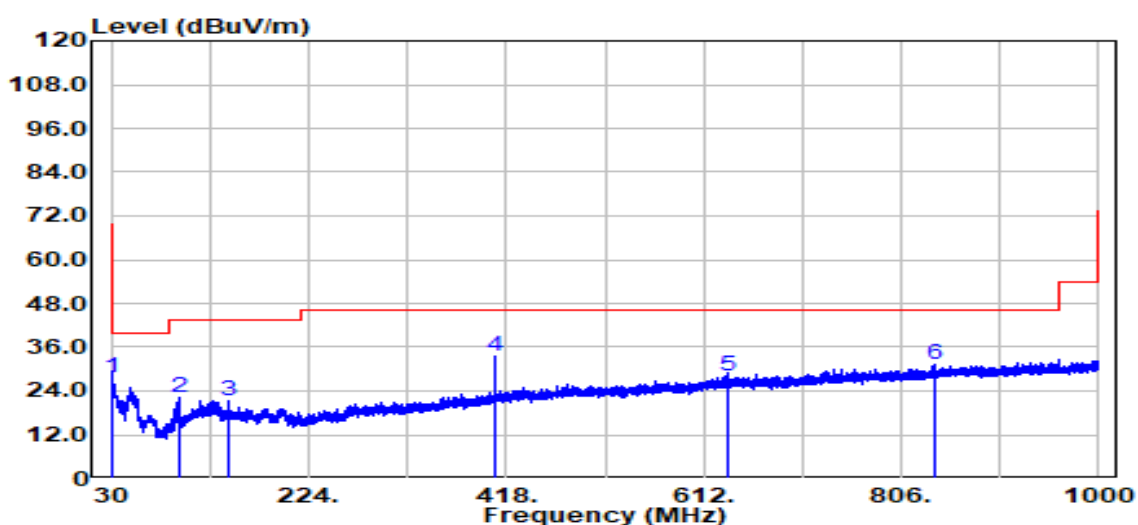

Frequency (MHz)	Detector Mode (PK/QP/AV)	Spectrum Reading Level (dBμV)	Factor (dB)	Actual FS (dBμV/m)	Limit @3m (dBμV/m)	Margin (dB)
30.000	Peak	30.74	-3.22	27.52	40.00	-12.48
96.203	Peak	36.14	-14.12	22.02	43.50	-21.48
145.673	Peak	31.91	-10.45	21.46	43.50	-22.04
408.058	Peak	39.35	-5.71	33.65	46.00	-12.35
636.250	Peak	28.93	-1.03	27.90	46.00	-18.10
840.071	Peak	29.53	1.88	31.41	46.00	-14.59

Note: No emission found between lowest internal used/generated frequency to 30MHz(9KHz~30MHz)

Test Mode	IEEE 802.11b 2437 MHz	Temp/Hum	24.6(°C)/ 62%RH
Test Item	30MHz-1GHz	Test Date	October 3, 2022
Polarize	Horizontal	Test Engineer	Tony Chao
Detector	Peak	EUT	Mode 3: 7.8" Color Digital Reader

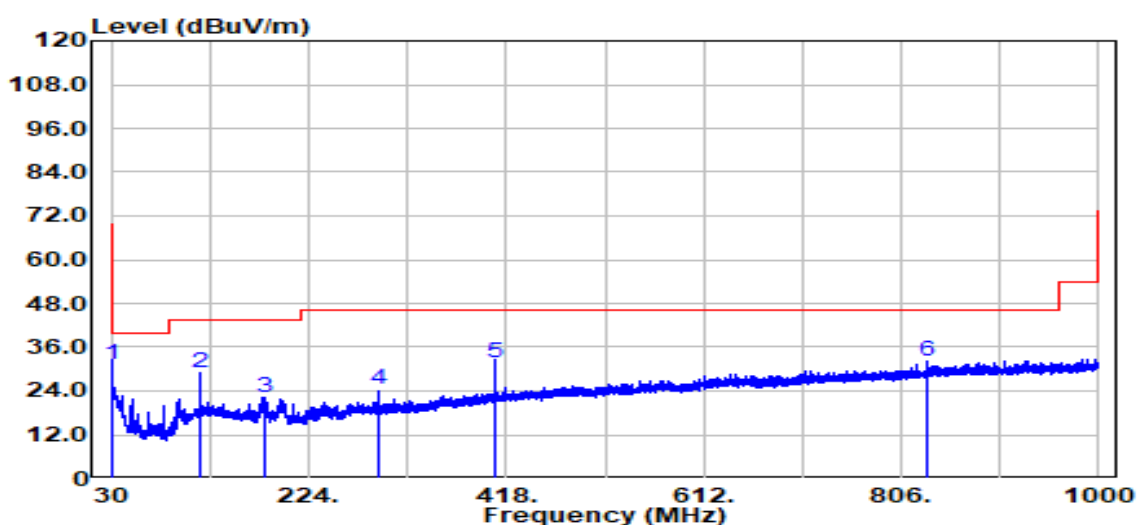

Frequency (MHz)	Detector Mode (PK/QP/AV)	Spectrum Reading Level (dB μ V)	Factor (dB)	Actual FS (dB μ V/m)	Limit @3m (dB μ V/m)	Margin (dB)
30.000	Peak	34.68	-3.22	31.46	40.00	-8.54
116.573	Peak	38.49	-9.72	28.77	43.50	-14.73
181.684	Peak	34.03	-11.74	22.28	43.50	-21.22
291.536	Peak	33.63	-8.96	24.67	46.00	-21.33
408.058	Peak	37.24	-5.71	31.53	46.00	-14.47
831.463	Peak	30.30	1.66	31.97	46.00	-14.03

Note: No emission found between lowest internal used/generated frequency to 30MHz(9KHz~30MHz)

Report No.: TMWK2210004067KR

Above 1G Test Data

Test Mode	IEEE 802.11b 2412 MHz	Temp/Hum	24.3(°C)/ 61%RH
Test Item	Harmonic	Test Date	September 8, 2022
Polarize	Vertical	Test Engineer	Tony Chao
Detector	Peak / Average		

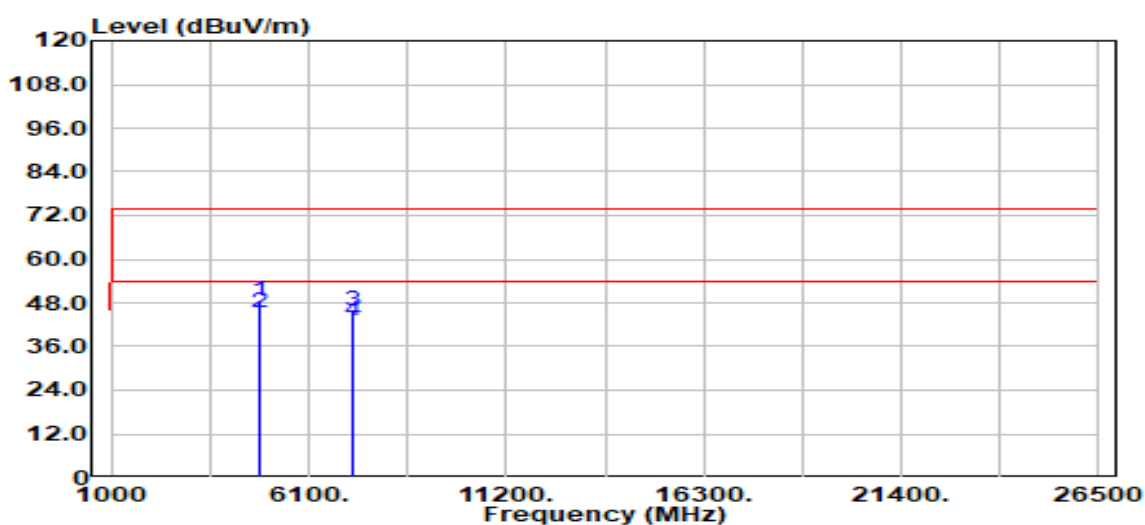

Frequency (MHz)	Detector Mode (PK/QP/AV)	Spectrum Reading Level (dBμV)	Factor (dB)	Actual FS (dBμV/m)	Limit @3m (dBμV/m)	Margin (dB)
4824.000	Peak	42.49	5.90	48.39	74.00	-25.61
4824.000	Average	39.41	5.90	45.31	54.00	-8.69
7236.000	Peak	32.47	13.31	45.79	74.00	-28.21
7236.000	Average	29.56	13.31	42.87	54.00	-11.13
N/A						

Remark:

1. Measuring frequencies from 1 GHz to the 10th harmonic of highest fundamental frequency.

Report No.: TMWK2210004067KR

Test Mode	IEEE 802.11b 2412 MHz	Temp/Hum	24.3(°C)/ 61%RH
Test Item	Harmonic	Test Date	September 8, 2022
Polarize	Horizontal	Test Engineer	Tony Chao
Detector	Peak / Average		

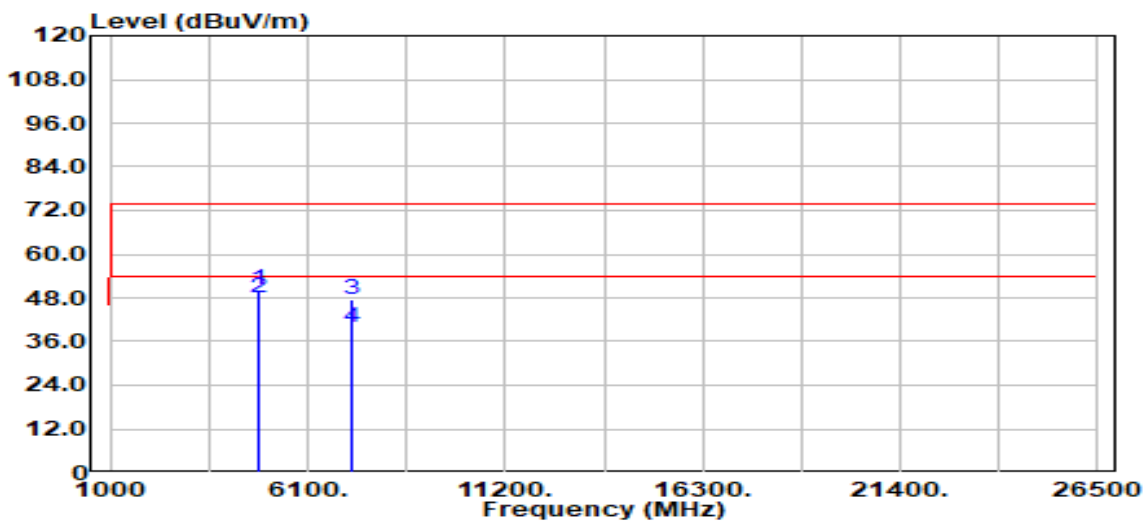

Frequency (MHz)	Detector Mode (PK/QP/AV)	Spectrum Reading Level (dBUV)	Factor (dB)	Actual FS (dBUV/m)	Limit @3m (dBUV/m)	Margin (dB)
4824.000	Peak	44.19	5.90	50.09	74.00	-23.91
4824.000	Average	42.04	5.90	47.94	54.00	-6.06
7236.000	Peak	34.44	13.31	47.75	74.00	-26.25
7236.000	Average	26.64	13.31	39.95	54.00	-14.05
N/A						

Remark:

1. Measuring frequencies from 1 GHz to the 10th harmonic of highest fundamental frequency.

Report No.: TMWK2210004067KR

Test Mode	IEEE 802.11b 2437 MHz	Temp/Hum	24.3(°C)/ 61%RH
Test Item	Harmonic	Test Date	September 8, 2022
Polarize	Vertical	Test Engineer	Tony Chao
Detector	Peak / Average		

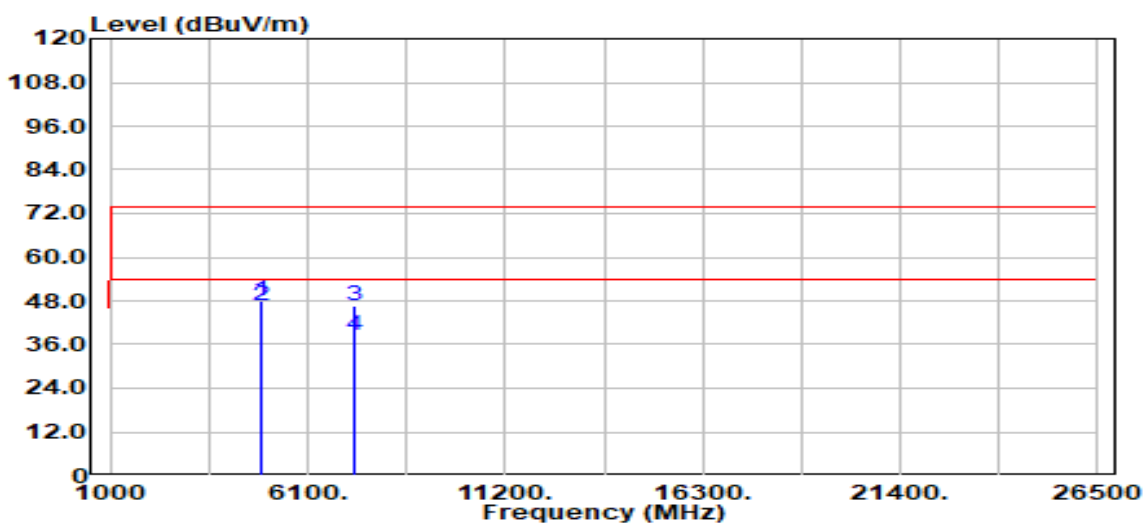

Frequency (MHz)	Detector Mode (PK/QP/AV)	Spectrum Reading Level (dBμV)	Factor (dB)	Actual FS (dBμV/m)	Limit @3m (dBμV/m)	Margin (dB)
4874.000	Peak	41.76	6.09	47.85	74.00	-26.15
4874.000	Average	40.73	6.09	46.82	54.00	-7.18
7311.000	Peak	33.48	13.33	46.81	74.00	-27.19
7311.000	Average	25.20	13.33	38.53	54.00	-15.47
N/A						

Remark:

1. Measuring frequencies from 1 GHz to the 10th harmonic of highest fundamental frequency.

Report No.: TMWK2210004067KR

Test Mode	IEEE 802.11b 2437 MHz	Temp/Hum	24.3(°C)/ 61%RH
Test Item	Harmonic	Test Date	September 8, 2022
Polarize	Horizontal	Test Engineer	Tony Chao
Detector	Peak / Average		

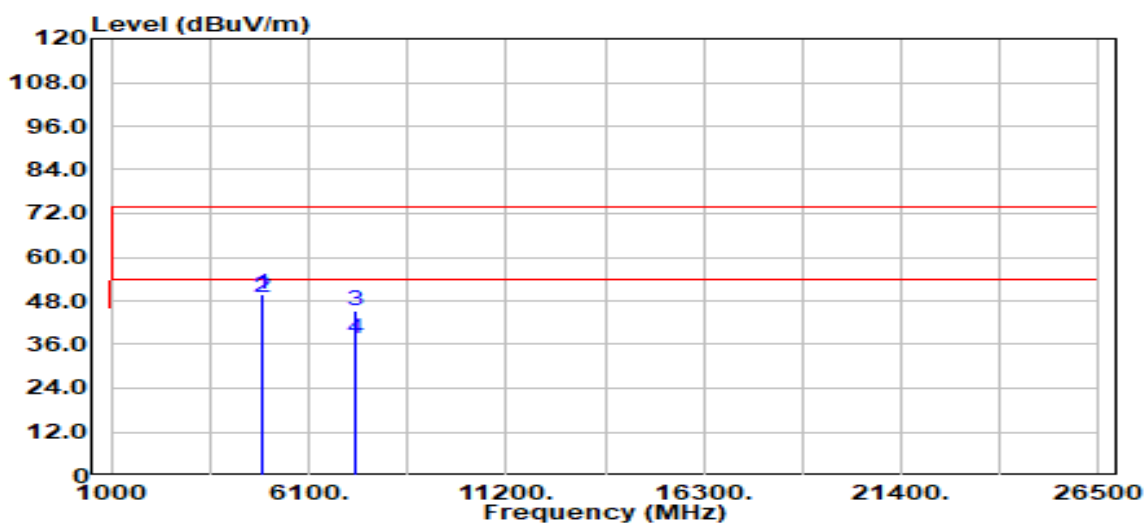

Frequency (MHz)	Detector Mode (PK/QP/AV)	Spectrum Reading Level (dBμV)	Factor (dB)	Actual FS (dBμV/m)	Limit @3m (dBμV/m)	Margin (dB)
4874.000	Peak	43.70	6.09	49.79	74.00	-24.21
4874.000	Average	42.65	6.09	48.74	54.00	-5.26
7311.000	Peak	31.97	13.33	45.30	74.00	-28.70
7311.000	Average	24.28	13.33	37.61	54.00	-16.39
N/A						

Remark:

1. Measuring frequencies from 1 GHz to the 10th harmonic of highest fundamental frequency.

Test Mode	IEEE 802.11b 2462 MHz	Temp/Hum	24.3(°C)/ 61%RH
Test Item	Harmonic	Test Date	September 8, 2022
Polarize	Vertical	Test Engineer	Ray Li
Detector	Peak / Average		

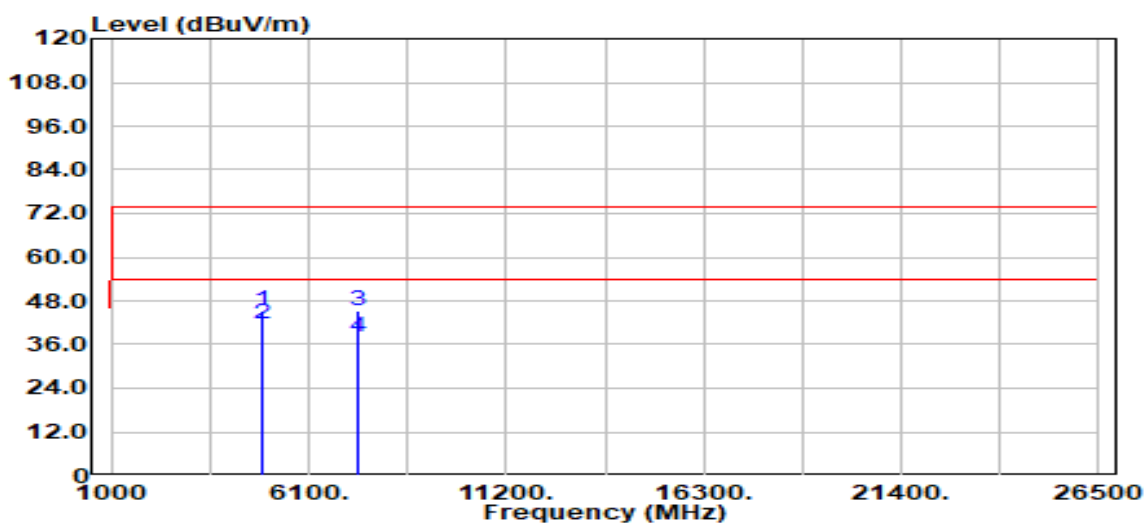

Frequency (MHz)	Detector Mode (PK/QP/AV)	Spectrum Reading Level (dBμV)	Factor (dB)	Actual FS (dBμV/m)	Limit @3m (dBμV/m)	Margin (dB)
4924.000	Peak	38.96	6.53	45.49	74.00	-28.51
4924.000	Average	34.92	6.53	41.45	54.00	-12.55
7386.000	Peak	31.84	13.33	45.18	74.00	-28.82
7386.000	Average	24.79	13.33	38.12	54.00	-15.88
N/A						

Remark:

1. Measuring frequencies from 1 GHz to the 10th harmonic of highest fundamental frequency.

Report No.: TMWK2210004067KR

Test Mode	IEEE 802.11b 2462 MHz	Temp/Hum	24.3(°C)/ 61%RH
Test Item	Harmonic	Test Date	September 8, 2022
Polarize	Horizontal	Test Engineer	Ray Li
Detector	Peak / Average		

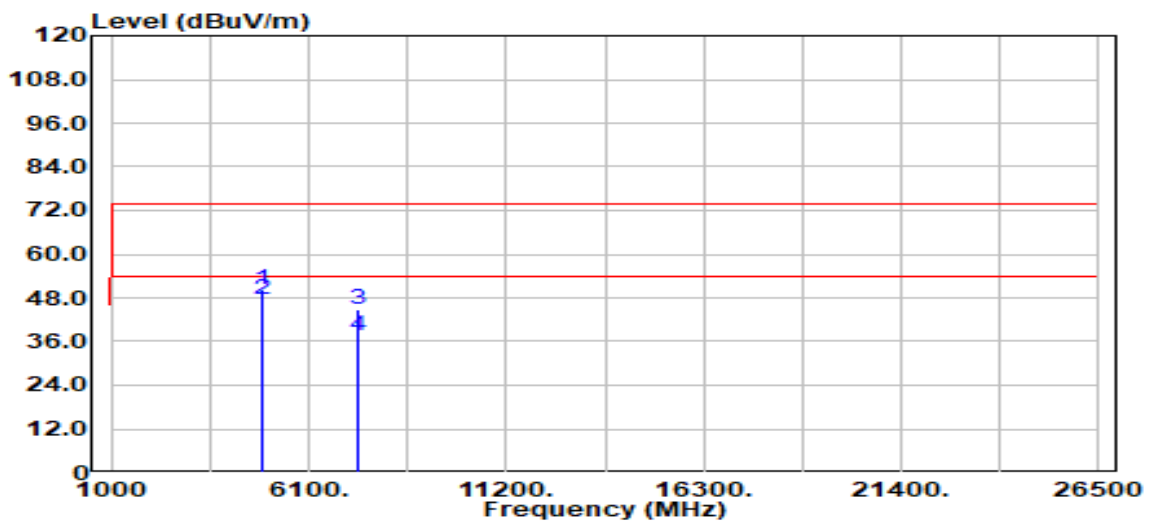

Frequency (MHz)	Detector Mode (PK/QP/AV)	Spectrum Reading Level (dBμV)	Factor (dB)	Actual FS (dBμV/m)	Limit @3m (dBμV/m)	Margin (dB)
4924.000	Peak	43.85	6.53	50.38	74.00	-23.62
4924.000	Average	40.96	6.53	47.49	54.00	-6.51
7386.000	Peak	31.56	13.33	44.89	74.00	-29.11
7386.000	Average	24.41	13.33	37.74	54.00	-16.26
N/A						

Remark:

1. Measuring frequencies from 1 GHz to the 10th harmonic of highest fundamental frequency.

Report No.: TMWK2210004067KR

Test Mode	IEEE 802.11g 2412 MHz	Temp/Hum	24.6(°C)/ 62%RH
Test Item	Harmonic	Test Date	October 3, 2022
Polarize	Vertical	Test Engineer	Ray Li
Detector	Peak / Average		

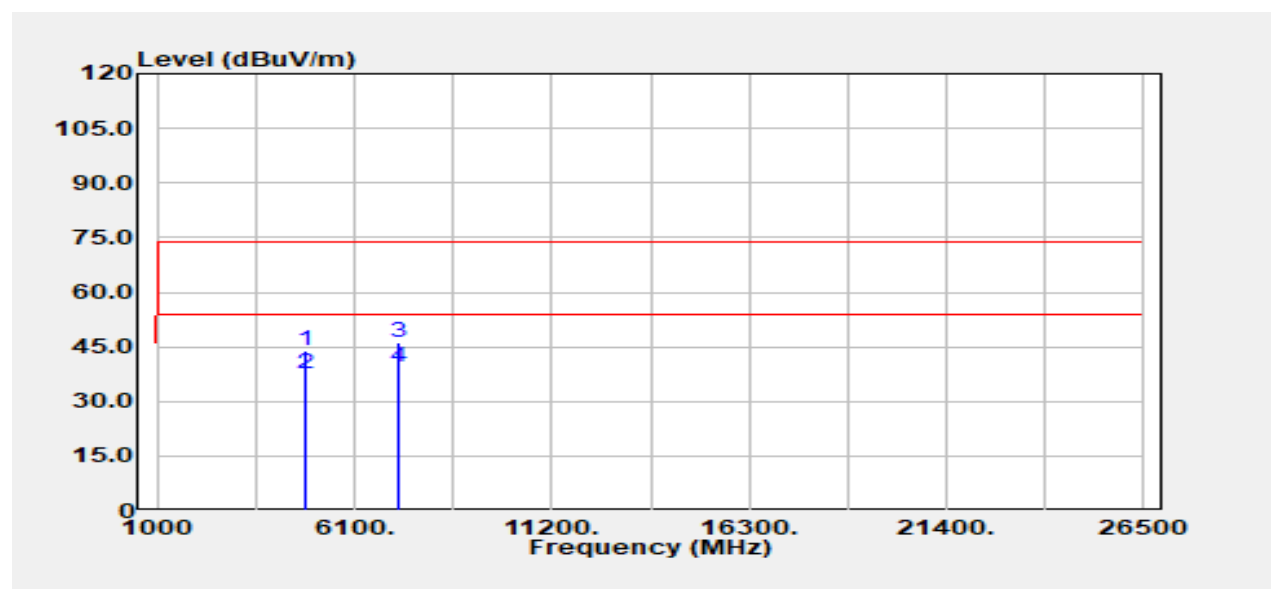

Frequency (MHz)	Detector Mode (PK/QP/AV)	Spectrum Reading Level (dBμV)	Factor (dB)	Actual FS (dBμV/m)	Limit @3m (dBμV/m)	Margin (dB)
4824.000	Peak	37.84	5.90	43.74	74.00	-30.26
4824.000	Average	31.88	5.90	37.78	54.00	-16.22
7236.000	Peak	32.68	13.31	45.99	74.00	-28.01
7236.000	Average	26.29	13.31	39.60	54.00	-14.40
N/A						

Remark:

1. Measuring frequencies from 1 GHz to the 10th harmonic of highest fundamental frequency.

Report No.: TMWK2210004067KR

Test Mode	IEEE 802.11g 2412 MHz	Temp/Hum	24.6(°C)/ 62%RH
Test Item	Harmonic	Test Date	October 3, 2022
Polarize	Horizontal	Test Engineer	Ray Li
Detector	Peak / Average		

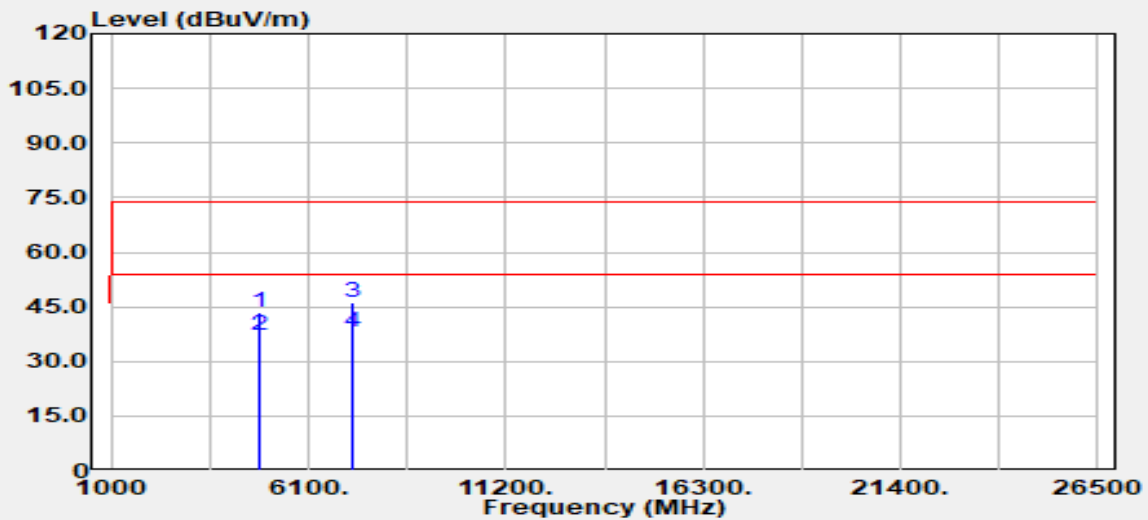

Frequency (MHz)	Detector Mode (PK/QP/AV)	Spectrum Reading Level (dBμV)	Factor (dB)	Actual FS (dBμV/m)	Limit @3m (dBμV/m)	Margin (dB)
4824.000	Peak	37.75	5.90	43.65	74.00	-30.35
4824.000	Average	31.13	5.90	37.03	54.00	-16.97
7236.000	Peak	32.84	13.31	46.15	74.00	-27.85
7236.000	Average	24.60	13.31	37.91	54.00	-16.09
N/A						

Remark:

1. Measuring frequencies from 1 GHz to the 10th harmonic of highest fundamental frequency.

Report No.: TMWK2210004067KR

Test Mode	IEEE 802.11g 2437 MHz	Temp/Hum	24.6(°C)/ 62%RH
Test Item	Harmonic	Test Date	October 3, 2022
Polarize	Vertical	Test Engineer	Ray Li
Detector	Peak / Average		

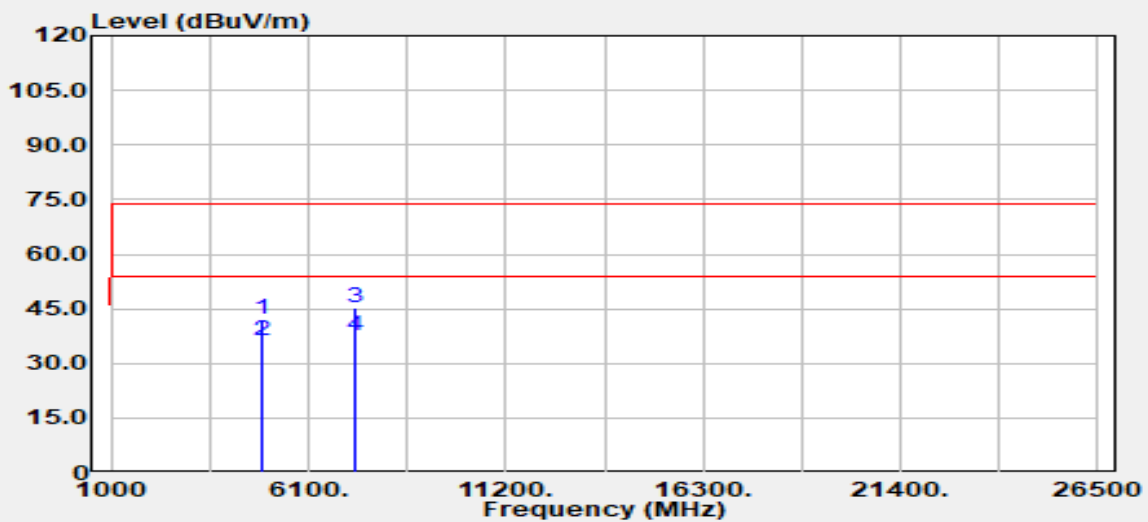

Frequency (MHz)	Detector Mode (PK/QP/AV)	Spectrum Reading Level (dBμV)	Factor (dB)	Actual FS (dBμV/m)	Limit @3m (dBμV/m)	Margin (dB)
4874.000	Peak	35.82	6.09	41.91	74.00	-32.09
4874.000	Average	30.12	6.09	36.21	54.00	-17.79
7311.000	Peak	31.84	13.33	45.17	74.00	-28.83
7311.000	Average	24.26	13.33	37.59	54.00	-16.41
N/A						

Remark:

1. Measuring frequencies from 1 GHz to the 10th harmonic of highest fundamental frequency.

Report No.: TMWK2210004067KR

Test Mode	IEEE 802.11g 2437 MHz	Temp/Hum	24.6(°C)/ 62%RH
Test Item	Harmonic	Test Date	October 3, 2022
Polarize	Horizontal	Test Engineer	Ray Li
Detector	Peak / Average		

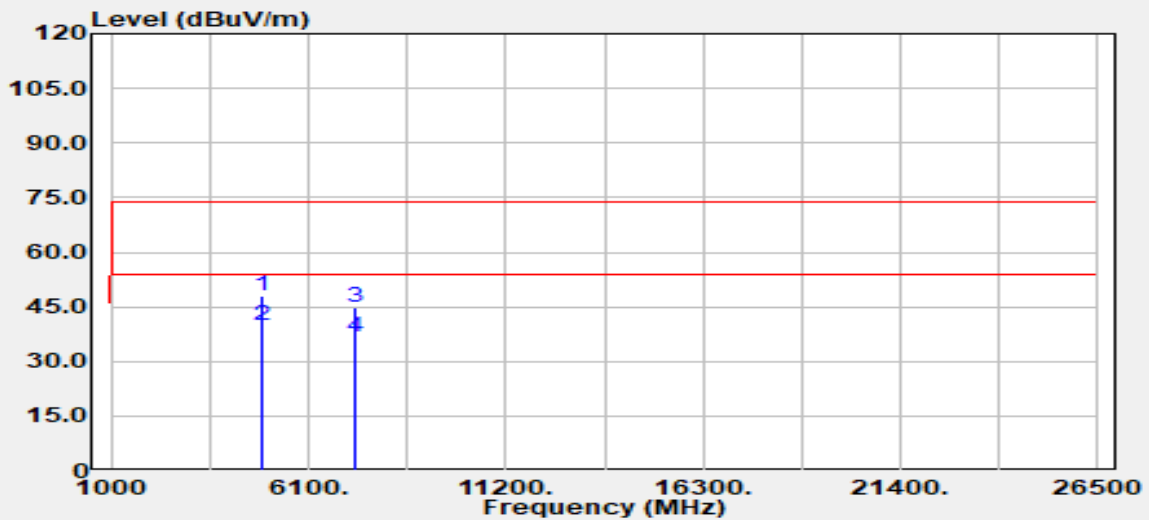

Frequency (MHz)	Detector Mode (PK/QP/AV)	Spectrum Reading Level (dBμV)	Factor (dB)	Actual FS (dBμV/m)	Limit @3m (dBμV/m)	Margin (dB)
4874.000	Peak	41.91	6.09	48.00	74.00	-26.00
4874.000	Average	33.69	6.09	39.78	54.00	-14.22
7311.000	Peak	31.72	13.33	45.05	74.00	-28.95
7311.000	Average	23.33	13.33	36.66	54.00	-17.34
N/A						

Remark:

1. Measuring frequencies from 1 GHz to the 10th harmonic of highest fundamental frequency.

Report No.: TMWK2210004067KR

Test Mode	IEEE 802.11g 2462 MHz	Temp/Hum	24.6(°C)/ 62%RH
Test Item	Harmonic	Test Date	October 3, 2022
Polarize	Vertical	Test Engineer	Ray Li
Detector	Peak / Average		

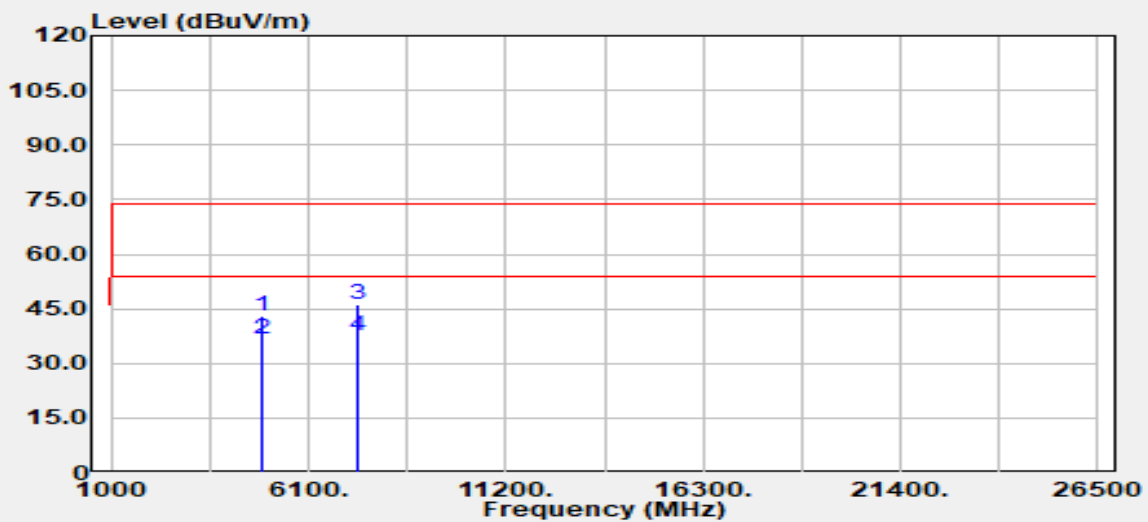

Frequency (MHz)	Detector Mode (PK/QP/AV)	Spectrum Reading Level (dBμV)	Factor (dB)	Actual FS (dBμV/m)	Limit @3m (dBμV/m)	Margin (dB)
4924.000	Peak	36.64	6.53	43.17	74.00	-30.83
4924.000	Average	30.24	6.53	36.77	54.00	-17.23
7386.000	Peak	32.78	13.33	46.11	74.00	-27.89
7386.000	Average	24.15	13.33	37.48	54.00	-16.52
N/A						

Remark:

1. Measuring frequencies from 1 GHz to the 10th harmonic of highest fundamental frequency.

Report No.: TMWK2210004067KR

Test Mode	IEEE 802.11g 2462 MHz	Temp/Hum	24.6(°C)/ 62%RH
Test Item	Harmonic	Test Date	October 3, 2022
Polarize	Horizontal	Test Engineer	Ray Li
Detector	Peak / Average		

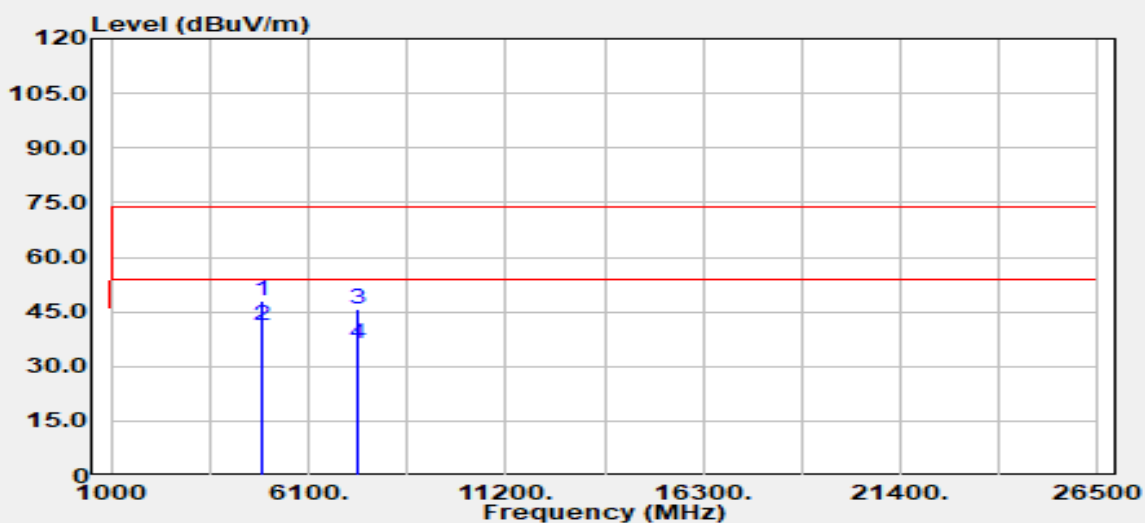

Frequency (MHz)	Detector Mode (PK/QP/AV)	Spectrum Reading Level (dBμV)	Factor (dB)	Actual FS (dBμV/m)	Limit @3m (dBμV/m)	Margin (dB)
4924.000	Peak	41.50	6.53	48.03	74.00	-25.97
4924.000	Average	34.57	6.53	41.09	54.00	-12.91
7386.000	Peak	32.45	13.33	45.78	74.00	-28.22
7386.000	Average	23.01	13.33	36.34	54.00	-17.66
N/A						

Remark:

1. Measuring frequencies from 1 GHz to the 10th harmonic of highest fundamental frequency.

Test Mode	IEEE 802.11n HT20 2412 MHz	Temp/Hum	24.6(°C)/ 62%RH
Test Item	Harmonic	Test Date	October 3, 2022
Polarize	Vertical	Test Engineer	Ray Li
Detector	Peak / Average		

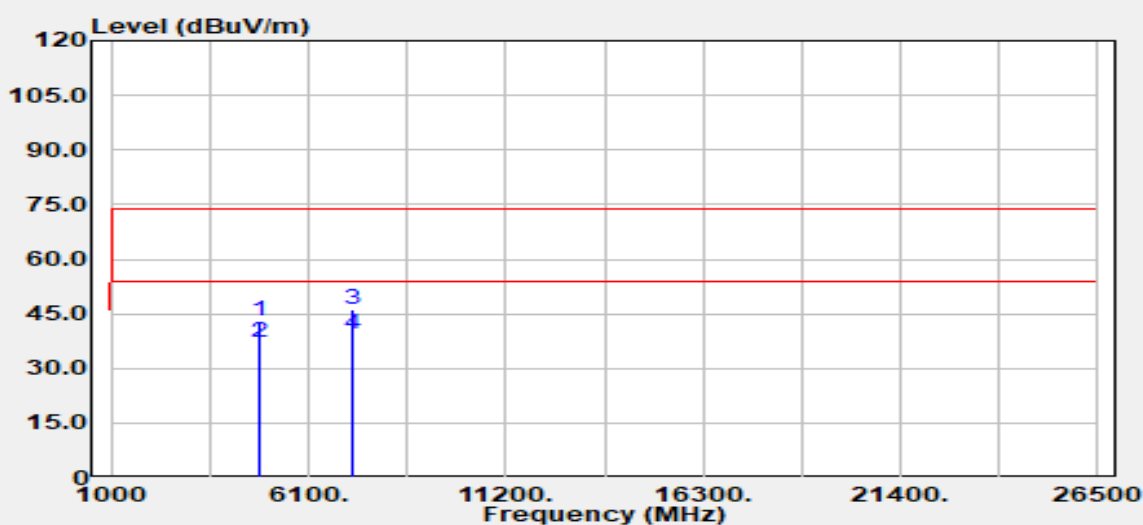

Frequency (MHz)	Detector Mode (PK/QP/AV)	Spectrum Reading Level (dBμV)	Factor (dB)	Actual FS (dBμV/m)	Limit @3m (dBμV/m)	Margin (dB)
4824.000	Peak	37.27	5.90	43.17	74.00	-30.83
4824.000	Average	31.33	5.90	37.23	54.00	-16.77
7236.000	Peak	32.78	13.31	46.09	74.00	-27.91
7236.000	Average	26.18	13.31	39.49	54.00	-14.51
N/A						

Remark:

1. Measuring frequencies from 1 GHz to the 10th harmonic of highest fundamental frequency.

Report No.: TMWK2210004067KR

Test Mode	IEEE 802.11n HT20 2412 MHz	Temp/Hum	24.6(°C)/ 62%RH
Test Item	Harmonic	Test Date	October 3, 2022
Polarize	Horizontal	Test Engineer	Ray Li
Detector	Peak / Average		

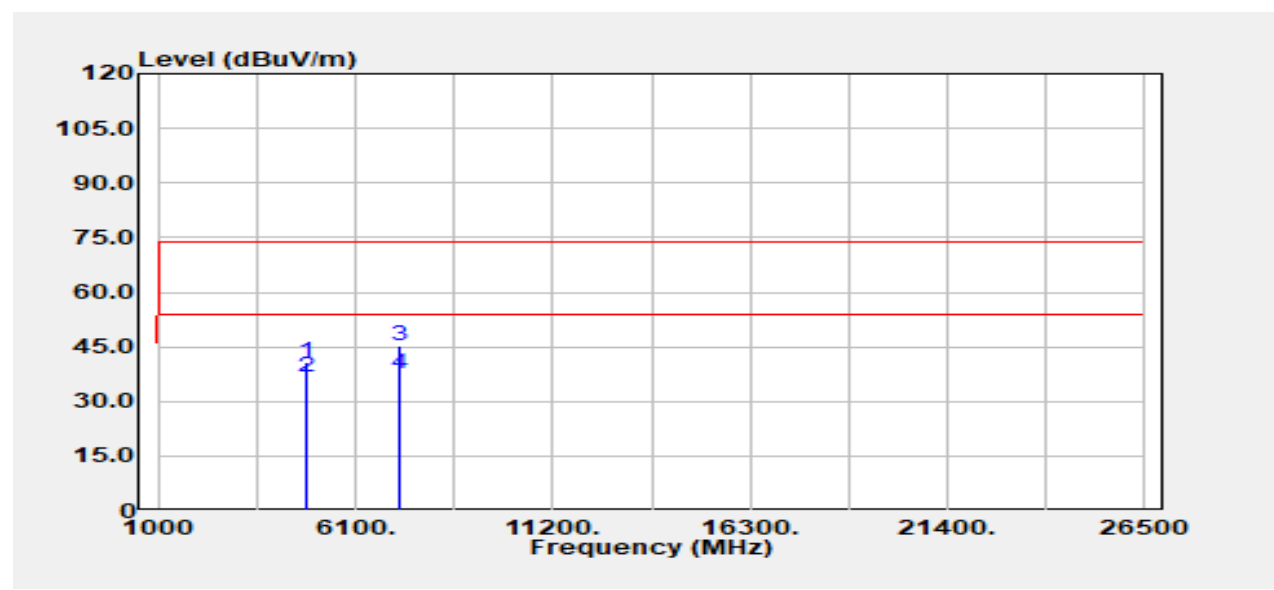

Frequency (MHz)	Detector Mode (PK/QP/AV)	Spectrum Reading Level (dBμV)	Factor (dB)	Actual FS (dBUV/m)	Limit @3m (dBUV/m)	Margin (dB)
4824.000	Peak	34.91	5.90	40.81	74.00	-33.19
4824.000	Average	30.82	5.90	36.72	54.00	-17.28
7236.000	Peak	31.83	13.31	45.14	74.00	-28.86
7236.000	Average	24.46	13.31	37.78	54.00	-16.22
N/A						

Remark:

1. Measuring frequencies from 1 GHz to the 10th harmonic of highest fundamental frequency.

Test Mode	IEEE 802.11n HT20 2437 MHz	Temp/Hum	24.6(°C)/ 62%RH
Test Item	Harmonic	Test Date	October 3, 2022
Polarize	Vertical	Test Engineer	Ray Li
Detector	Peak / Average		

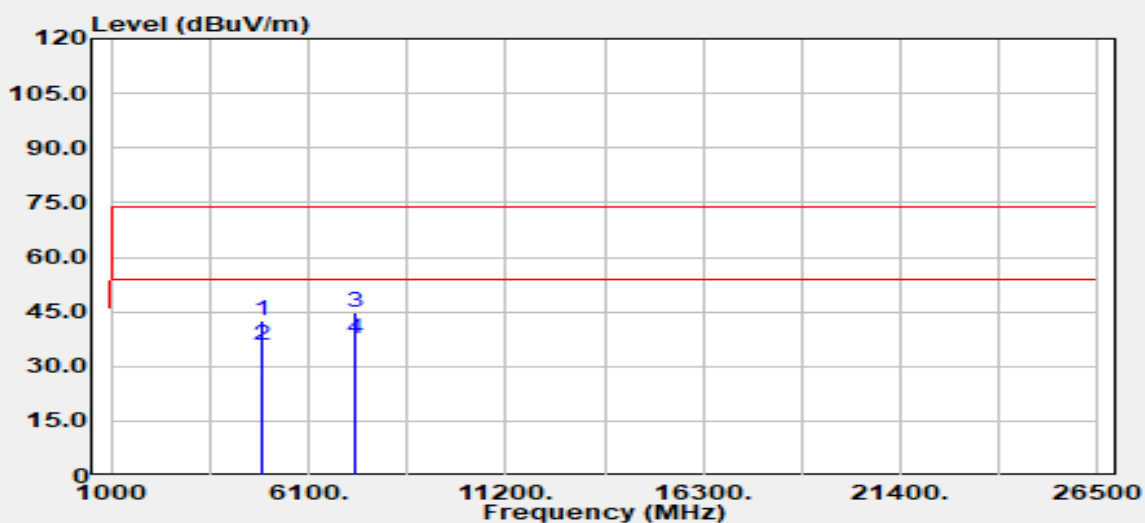

Frequency (MHz)	Detector Mode (PK/QP/AV)	Spectrum Reading Level (dBμV)	Factor (dB)	Actual FS (dBμV/m)	Limit @3m (dBμV/m)	Margin (dB)
4874.000	Peak	36.48	6.09	42.57	74.00	-31.43
4874.000	Average	29.62	6.09	35.71	54.00	-18.29
7311.000	Peak	31.65	13.33	44.99	74.00	-29.01
7311.000	Average	24.04	13.33	37.38	54.00	-16.62
N/A						

Remark:

1. Measuring frequencies from 1 GHz to the 10th harmonic of highest fundamental frequency.

Report No.: TMWK2210004067KR

Test Mode	IEEE 802.11n HT20 2437 MHz	Temp/Hum	24.6(°C)/ 62%RH
Test Item	Harmonic	Test Date	October 3, 2022
Polarize	Horizontal	Test Engineer	Ray Li
Detector	Peak / Average		

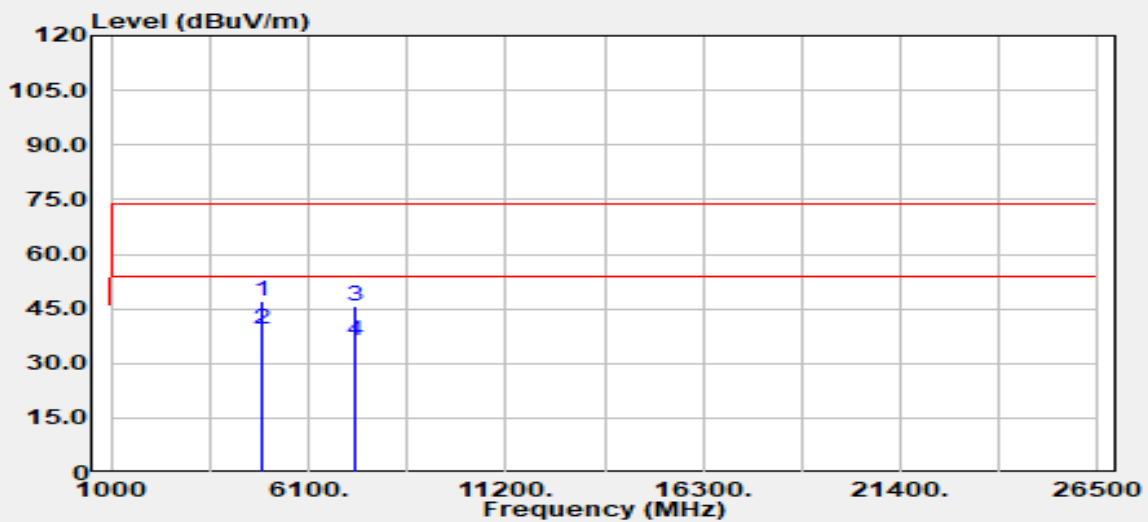

Frequency (MHz)	Detector Mode (PK/QP/AV)	Spectrum Reading Level (dB μ V)	Factor (dB)	Actual FS (dB μ V/m)	Limit @3m (dB μ V/m)	Margin (dB)
4874.000	Peak	40.82	6.09	46.91	74.00	-27.09
4874.000	Average	33.40	6.09	39.49	54.00	-14.51
7311.000	Peak	32.21	13.33	45.54	74.00	-28.46
7311.000	Average	22.76	13.33	36.09	54.00	-17.91
N/A						

Remark:

1. Measuring frequencies from 1 GHz to the 10th harmonic of highest fundamental frequency.

Report No.: TMWK2210004067KR

Test Mode	IEEE 802.11n HT20 2462 MHz	Temp/Hum	24.6(°C)/ 62%RH
Test Item	Harmonic	Test Date	October 3, 2022
Polarize	Vertical	Test Engineer	Ray Li
Detector	Peak / Average		

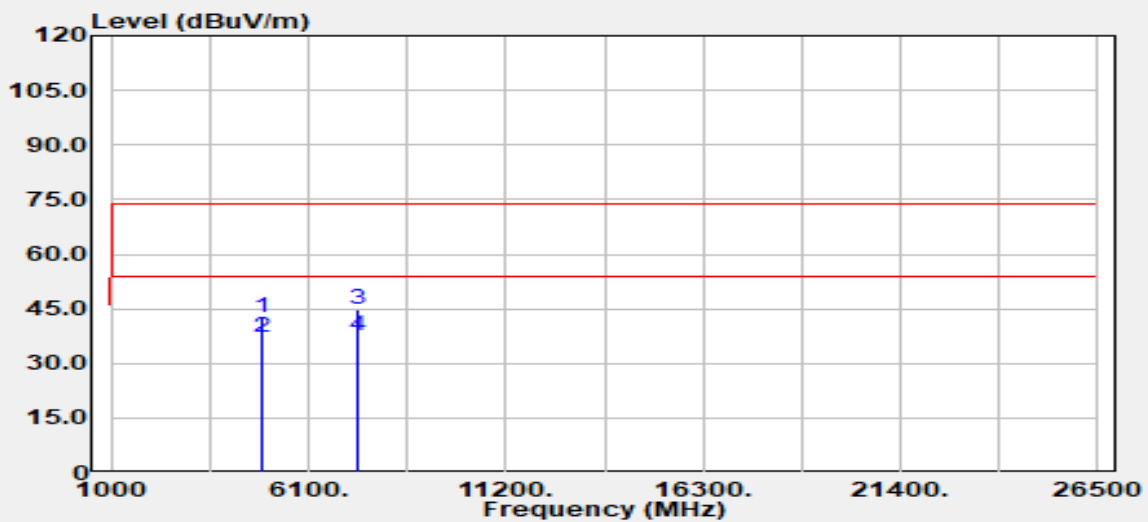

Frequency (MHz)	Detector Mode (PK/QP/AV)	Spectrum Reading Level (dBμV)	Factor (dB)	Actual FS (dBμV/m)	Limit @3m (dBμV/m)	Margin (dB)
4924.000	Peak	35.98	6.53	42.51	74.00	-31.49
4924.000	Average	30.80	6.53	37.33	54.00	-16.67
7386.000	Peak	31.32	13.33	44.66	74.00	-29.34
7386.000	Average	24.27	13.33	37.61	54.00	-16.39
N/A						

Remark:

1. Measuring frequencies from 1 GHz to the 10th harmonic of highest fundamental frequency.

Report No.: TMWK2210004067KR

Test Mode	IEEE 802.11n HT20 2462 MHz	Temp/Hum	24.6(°C)/ 62%RH
Test Item	Harmonic	Test Date	October 3, 2022
Polarize	Horizontal	Test Engineer	Ray Li
Detector	Peak / Average		

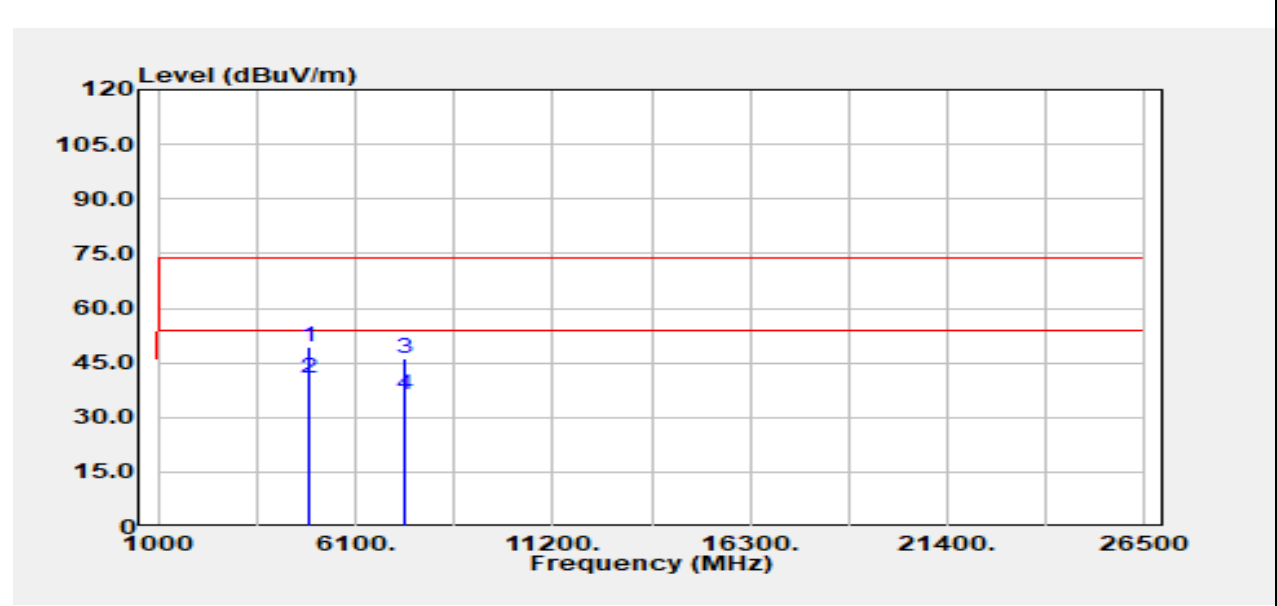

Frequency (MHz)	Detector Mode (PK/QP/AV)	Spectrum Reading Level (dBµV)	Factor (dB)	Actual FS (dBµV/m)	Limit @3m (dBµV/m)	Margin (dB)
4924.000	Peak	42.79	6.53	49.32	74.00	-24.68
4924.000	Average	34.25	6.53	40.78	54.00	-13.22
7386.000	Peak	33.02	13.33	46.35	74.00	-27.65
7386.000	Average	22.96	13.33	36.30	54.00	-17.70
N/A						

Remark:

1. Measuring frequencies from 1 GHz to the 10th harmonic of highest fundamental frequency.

- End of Test Report -