



FCC TEST REPORT

REPORT NO.: RF990430E03-1

MODEL NO.: E60814, PocketBook 602, MD 86371, CEB02

RECEIVED: Apr. 29, 2010

TESTED: May 24 to Jun. 02, 2010

ISSUED: July 22, 2010

APPLICANT: NETRONIX , INC.

ADDRESS: No. 945, Boai St., Jubei City,
Hsin-Chu,302,Taiwan, R.O.C.

ISSUED BY: Bureau Veritas Consumer Products Services (H.K.)
Ltd., Taoyuan Branch Hsin Chu Laboratory

LAB ADDRESS: No. 81-1, Lu Liao Keng, 9th Ling, Wu Lung Tsuen,
Chiung Lin Hsiang, Hsin Chu Hsien 307, Taiwan

This test report consists of 81 pages in total. It may be duplicated completely for legal use with the approval of the applicant. It should not be reproduced except in full, without the written approval of our laboratory. The client should not use it to claim product certification, approval, or endorsement by TAF or any government agencies. The test results in the report only apply to the tested sample.



TABLE OF CONTENTS

1	CERTIFICATION	4
2	SUMMARY OF TEST RESULTS.....	5
2.1	MEASUREMENT UNCERTAINTY	6
3	GENERAL INFORMATION	7
3.1	GENERAL DESCRIPTION OF EUT.....	7
3.2	DESCRIPTION OF TEST MODES.....	9
3.3	TEST MODE APPLICABILITY AND TESTED CHANNEL DETAIL:	10
3.4	GENERAL DESCRIPTION OF APPLIED STANDARDS	12
3.5	DESCRIPTION OF SUPPORT UNITS	13
3.6	CONFIGURATION OF SYSTEM UNDER TEST.....	14
4	TEST PROCEDURES AND RESULTS	15
4.1	CONDUCTED EMISSION MEASUREMENT	15
4.1.1	LIMITS OF CONDUCTED EMISSION MEASUREMENT.....	15
4.1.2	TEST INSTRUMENTS.....	15
4.1.3	TEST PROCEDURES	16
4.1.4	TEST SETUP	16
4.1.5	EUT OPERATING CONDITIONS.....	17
4.1.6	TEST RESULTS	18
4.2	NUMBER OF HOPPING FREQUENCY USED	20
4.2.1	LIMIT OF HOPPING FREQUENCY USED.....	20
4.2.2	TEST INSTRUMENTS.....	20
4.2.3	TEST PROCEDURES	20
4.2.4	DEVIATION FROM TEST STANDARD	20
4.2.5	TEST SETUP	21
4.2.6	TEST RESULTS	21
4.3	DWELL TIME ON EACH CHANNEL	25
4.3.1	LIMIT OF DWELL TIME USED	25
4.3.2	TEST INSTRUMENTS.....	25
4.3.3	TEST PROCEDURES	25
4.3.4	DEVIATION FROM TEST STANDARD	26
4.3.5	TEST SETUP	26
4.3.6	TEST RESULTS	26
4.4	CHANNEL BANDWIDTH	38
4.4.1	LIMITS OF CHANNEL BANDWIDTH	38
4.4.2	TEST INSTRUMENTS.....	38
4.4.3	TEST PROCEDURE.....	38
4.4.4	DEVIATION FROM TEST STANDARD	38
4.4.5	TEST SETUP	39
4.4.6	EUT OPERATING CONDITION	39
4.4.7	TEST RESULTS	40
4.5	HOPPING CHANNEL SEPARATION	46
4.5.1	LIMIT OF HOPPING CHANNEL SEPARATION.....	46
4.5.2	TEST INSTRUMENTS.....	46
4.5.3	TEST PROCEDURES	46



A D T

4.5.4	DEVIATION FROM TEST STANDARD	47
4.5.5	TEST SETUP	47
4.5.6	TEST RESULTS	48
4.6	MAXIMUM PEAK OUTPUT POWER	54
4.6.1	LIMITS OF MAXIMUM PEAK OUTPUT POWER MEASUREMENT	54
4.6.2	INSTRUMENTS	54
4.6.3	TEST PROCEDURES	54
4.6.4	DEVIATION FROM TEST STANDARD	54
4.6.5	TEST SETUP	55
4.6.6	EUT OPERATING CONDITION	55
4.6.7	TEST RESULTS	56
4.7	RADIATED EMISSION MEASUREMENT	62
4.7.1	LIMITS OF RADIATED EMISSION MEASUREMENT	62
4.7.2	TEST INSTRUMENTS.....	63
4.7.3	TEST PROCEDURES	64
4.7.4	DEVIATION FROM TEST STANDARD	64
4.7.5	TEST SETUP	65
4.7.6	TEST RESULTS	66
4.8	CONDUCTED OUT-BAND EMISSION MEASUREMENT.....	73
4.8.1	LIMITS OF CONDUCTED OUT-BAND EMISSION MEASUREMENT.....	73
4.8.2	TEST INSTRUMENTS.....	73
4.8.3	TEST PROCEDURE.....	73
4.8.4	DEVIATION FROM TEST STANDARD	73
4.8.5	EUT OPERATING CONDITION	73
4.8.6	TEST RESULTS	74
5	INFORMATION ON THE TESTING LABORATORIES.....	80
6	APPENDIX A - MODIFICATIONS RECORDERS FOR ENGINEERING CHANGES TO THE EUT BY THE LAB.....	81



1 CERTIFICATION

PRODUCT : 6"ebook reader
BRAND NAME : Netronix, PocketBook, GreenBook, MEDION, Carrefour
MODEL NO. : E60814, PocketBook 602, MD 86371, CEB02
APPLICANT : NETRONIX , INC.
TESTED DATE : May 24 to Jun. 02, 2010
TEST SAMPLE : ENGINEERING SAMPLE
STANDARDS : 47 CFR Part 15, Subpart C (Section 15.247)
ANSI C63.4-2003

The above equipment (Model: E60814) has been tested by **Bureau Veritas Consumer Products Services (H.K.) Ltd., Taoyuan Branch**, and found compliance with the requirement of the above standards. The test record, data evaluation & Equipment Under Test (EUT) configurations represented herein are true and accurate accounts of the measurements of the sample's EMC characteristics under the conditions specified in this report.

PREPARED BY : Midoli Peng , **DATE:** July 22, 2010
(Midoli Peng, Specialist)

TECHNICAL ACCEPTANCE : Hank Chung , **DATE:** July 22, 2010
(Hank Chung, Deputy Manager)

APPROVED BY : May Chen , **DATE:** July 22, 2010
(May Chen, Deputy Manager)

2 SUMMARY OF TEST RESULTS

The EUT has been tested according to the following specifications:

APPLIED STANDARD: 47 CFR Part 15, Subpart C			
Standard Section	Test Type and Limit	Result	REMARK
15.207	AC Power Conducted Emission	PASS	Meet the requirement of limit Minimum passing margin is -12.27dB at 0.150MHz
15.247(a)(1)(I)-(ii)	Number of Hopping Frequency Used Spec.: At least 15 channels	PASS	Meet the requirement of limit
15.247(a)(1)(ii)	Dwell Time on Each Channel Spec.: Max. 0.4 second within 31.6 second	PASS	Meet the requirement of limit
15.247(a)(1)(I)-(ii)	Hopping Channel Separation Spec. : Min. 25 kHz or two-thirds of 20 dB bandwidth, which ever is greater	PASS	Meet the requirement of limit
15.247(a)(2)	Spectrum Bandwidth of a Frequency Hopping Sequence Spread Spectrum System	PASS	Meet the requirement of limit
15.247(b)	Maximum Peak Output Power Spec.: max. 125mW	PASS	Meet the requirement of limit
15.247(c)	Transmitter Radiated Emissions Spec.: Table 15.209	PASS	Meet the requirement of limit Minimum passing margin is -1.6dB at 600.00MHz
15.247(c)	Conducted Out-Band Emissions Measurement	PASS	Meet the requirement of limit
15.203	Antenna Requirement	PASS	No antenna connector is used.

2.1 MEASUREMENT UNCERTAINTY

Where relevant, the following measurement uncertainty levels have been estimated for tests performed on the EUT as specified in CISPR 16-4-2:

This uncertainty represents an expanded uncertainty expressed at approximately the 95% confidence level using a coverage factor of $k=2$.

Measurement	Value
Conducted emissions	2.45 dB
Radiated emissions (30MHz-1GHz)	3.94 dB
Radiated emissions (1GHz -18GHz)	2.49 dB
Radiated emissions (18GHz -40GHz)	2.70 dB



3 GENERAL INFORMATION

3.1 GENERAL DESCRIPTION OF EUT

PRODUCT	6"ebook reader
MODEL NO.	E60814, PocketBook 602, MD 86371, CEB02
FCC ID	NOIE60814
POWER SUPPLY	DC 5V from host equipment or power adapter DC 3.7V from battery
MODULATION TYPE	GFSK, $\pi/4$ -DQPSK, 8DPSK
MODULATION TECHNOLOGY	FHSS
TRANSFER RATE	DH 1, DH 3, DH 5
OPRTAING FREQUENCY	2402 ~ 2480MHz
NUMBER OF CHANNEL	79
MAXIMUM OUTPUT POWER	GFSK: 0.4 mW 8DPSK: 0.3 mW $\pi/4$ – DQPSK: 0.4 mW
ANTENNA TYPE	Chip antenna (Gain : 1.8dBi)
DATA CABLE	USB cable (shielded, 1.0m)
I/O PORTS	USB port x 1(USB 2.0) headset port x 1 Memory slot port x 1(SD)
ASSOCIATED DEVICES	Adapter x 1 Rechargeable Battery x 1

NOTE:

1. There are Bluetooth technology and WLAN technology used for the EUT. <the WLAN test data please refer "RF990430E03">

2. The EUT has below brand names and model names which are identical to each other in all aspects except for the following :

Brand Name	Model No.	Description
Netronix	E60814	
PocketBook	PocketBook 602	Same as model : E60814 except for different design of Enclosure
GreenBook	E60814	Same as model : E60814 except for different color of Enclosure
MEDION	MD 86371	
Carrefour	CEB02	

From the above models, model: **E60814** <brand: Netronix > was selected as representative model for the test and its data was recorded in this report.

3. The EUT could be supplied with a power adapter or a rechargeable battery as the following table:

Item	Brand	Model No.	Spec.
Adapter	DVE	DSA-6G-05 FUS 050100	AC I/P: 100~240V, 50~60Hz, 0.2A DC O/P: 5V, 1A DC output cable (unshielded, 1.56m)
Rechargeable battery	Power Source Energy Co , Ltd.	H354070	DC 3.7V, 1000mAh

4. The EUT was pre-tested under following test modes :

Pre-test Mode	Description	Power Source
Mode A	Level-set	Battery
Mode B	Tower-set	Battery
Mode C	Tower-set	Adapter

The worst radiated emission was found in **Mode C**. Therefore only the test data of the modes were recorded in this report.

5. The above EUT information was declared by the manufacturer and for more detailed features description, please refer to the manufacturer's specifications or User's Manual.



3.2 DESCRIPTION OF TEST MODES

Seventy-nine channels are provided to this EUT.

Channel	Freq. (MHz)	Channel	Freq. (MHz)	Channel	Freq. (MHz)	Channel	Freq. (MHz)
0	2402	20	2422	40	2442	60	2462
1	2403	21	2423	41	2443	61	2463
2	2404	22	2424	42	2444	62	2464
3	2405	23	2425	43	2445	63	2465
4	2406	24	2426	44	2446	64	2466
5	2407	25	2427	45	2447	65	2467
6	2408	26	2428	46	2448	66	2468
7	2409	27	2429	47	2449	67	2469
8	2410	28	2430	48	2450	68	2470
9	2411	29	2431	49	2451	69	2471
10	2412	30	2432	50	2452	70	2472
11	2413	31	2433	51	2453	71	2473
12	2414	32	2434	52	2454	72	2474
13	2415	33	2435	53	2455	73	2475
14	2416	34	2436	54	2456	74	2476
15	2417	35	2437	55	2457	75	2477
16	2418	36	2438	56	2458	76	2478
17	2419	37	2439	57	2459	77	2479
18	2420	38	2440	58	2460	78	2480
19	2421	39	2441	59	2461		

3.3 TEST MODE APPLICABILITY AND TESTED CHANNEL DETAIL:

The device has several types and different accessory, therefore the worst case base on investigation by different combination for each test item and its data was recorded in this report.

EUT CONFIGURE MODE	APPLICABLE TO				DESCRIPTION
	PLC	RE < 1G	RE ≥ 1G	APCM	
A	√	-	-	-	Level-set + Adapter
B	-	√	√	√	Tower-set + Adapter

Where **PLC**: Power Line Conducted Emission **RE < 1G**: Radiated Emission below 1GHz
RE ≥ 1G: Radiated Emission above 1GHz **APCM**: Antenna Port Conducted Measurement

Power Line Conducted Emission Test:

- Pre-Scan has been conducted to determine the worst-case mode from all possible combinations between available modulations, data rates and antenna ports (if EUT with antenna diversity architecture).
- Following channel(s) was (were) selected for the final test as listed below.

Available Channel	Tested Channel	Modulation Technology	Modulation Type	Packet Type	EUT CONFIGURE MODE
0 to 78	0	FHSS	GFSK	DH5	A

Radiated Emission Test (Below 1 GHz):

- Pre-Scan has been conducted to determine the worst-case mode from all possible combinations between available modulations, data rates and antenna ports (if EUT with antenna diversity architecture).
- Following channel(s) was (were) selected for the final test as listed below.

Available Channel	Tested Channel	Modulation Technology	Modulation Type	Packet Type	EUT CONFIGURE MODE
0 to 78	0	FHSS	GFSK	DH5	B

Radiated Emission Test (Above 1 GHz):

- Pre-Scan has been conducted to determine the worst-case mode from all possible combinations between available modulations, data rates and antenna ports (if EUT with antenna diversity architecture).
- Following channel(s) was (were) selected for the final test as listed below.

Available Channel	Tested Channel	Modulation Technology	Modulation Type	Packet Type	EUT CONFIGURE MODE
0 to 78	0, 39, 78	FHSS	GFSK	DH5	B
0 to 78	0, 39, 78	FHSS	8DPSK	DH5	B

Conducted Out-Band Measurement:

- Pre-Scan has been conducted to determine the worst-case mode from all possible combinations between available modulations, data rates and antenna ports (if EUT with antenna diversity architecture).
- Following channel(s) was (were) selected for the final test as listed below.

Available Channel	Tested Channel	Modulation Technology	Modulation Type	Packet Type	EUT CONFIGURE MODE
0 to 78	0, 78	FHSS	GFSK	DH5	B
0 to 78	0, 78	FHSS	8DPSK	DH5	B
0 to 78	0, 78	FHSS	$\pi/4$ -DQPSK	DH5	B

Antenna Port Conducted Measurement:

- Pre-Scan has been conducted to determine the worst-case mode from all possible combinations between available modulations, data rates and antenna ports (if EUT with antenna diversity architecture).
- Following channel(s) was (were) selected for the final test as listed below.

Available Channel	Tested Channel	Modulation Technology	Modulation Type	Packet Type	EUT CONFIGURE MODE
0 to 78	0, 39, 78	FHSS	GFSK	DH5	B
0 to 78	0, 39, 78	FHSS	8DPSK	DH5	B
0 to 78	0, 39, 78	FHSS	$\pi/4$ -DQPSK	DH5	B

TEST CONDITION:

APPLICABLE TO	ENVIRONMENTAL CONDITIONS	INPUT POWER	TESTED BY
RE \geq 1G	28deg. C, 60%RH, 1015 hPa	120Vac, 60Hz	Wen Yu
RE $<$ 1G	30deg. C, 60%RH, 1015 hPa	120Vac, 60Hz	Wen Yu
PLC	25deg. C, 57%RH, 1015 hPa	120Vac, 60Hz	Leo Peng
APCM	25deg. C, 60%RH, 1015 hPa	120Vac, 60Hz	Frank Liu



3.4 GENERAL DESCRIPTION OF APPLIED STANDARDS

The EUT is a RF product. According to the specifications of the manufacturer, it must comply with the requirements of the following standards:

FCC Part 15, Subpart C. (15.247)
ANSI C63.4 : 2003

All test items have been performed and recorded as per the above standards.

NOTE: The EUT is also considered as a kind of computer peripheral, because the connection to computer is necessary for typical use. It has been verified to comply with the requirements of FCC Part 15, Subpart B, Class B (DoC). The test report has been issued separately.



3.5 DESCRIPTION OF SUPPORT UNITS

The EUT has been tested as an independent unit together with other necessary accessories or support units. The following support units or accessories were used to form a representative test configuration during the tests.

NO.	PRODUCT	BRAND	MODEL NO.	SERIAL NO.	FCC ID
1	EARPHONE	PHILIPS	SBC HL145	8710895759472	NA
2	WIRELESS CONNECTIVITY TEST SET	Agilent	N4010A	MY46320453	NA

NO.	SIGNAL CABLE DESCRIPTION OF THE ABOVE SUPPORT UNITS
1	Audio Cable(1.5m)
2	NA

NOTE: All power cords of the above support units are non shielded (1.8m).

3.6 CONFIGURATION OF SYSTEM UNDER TEST

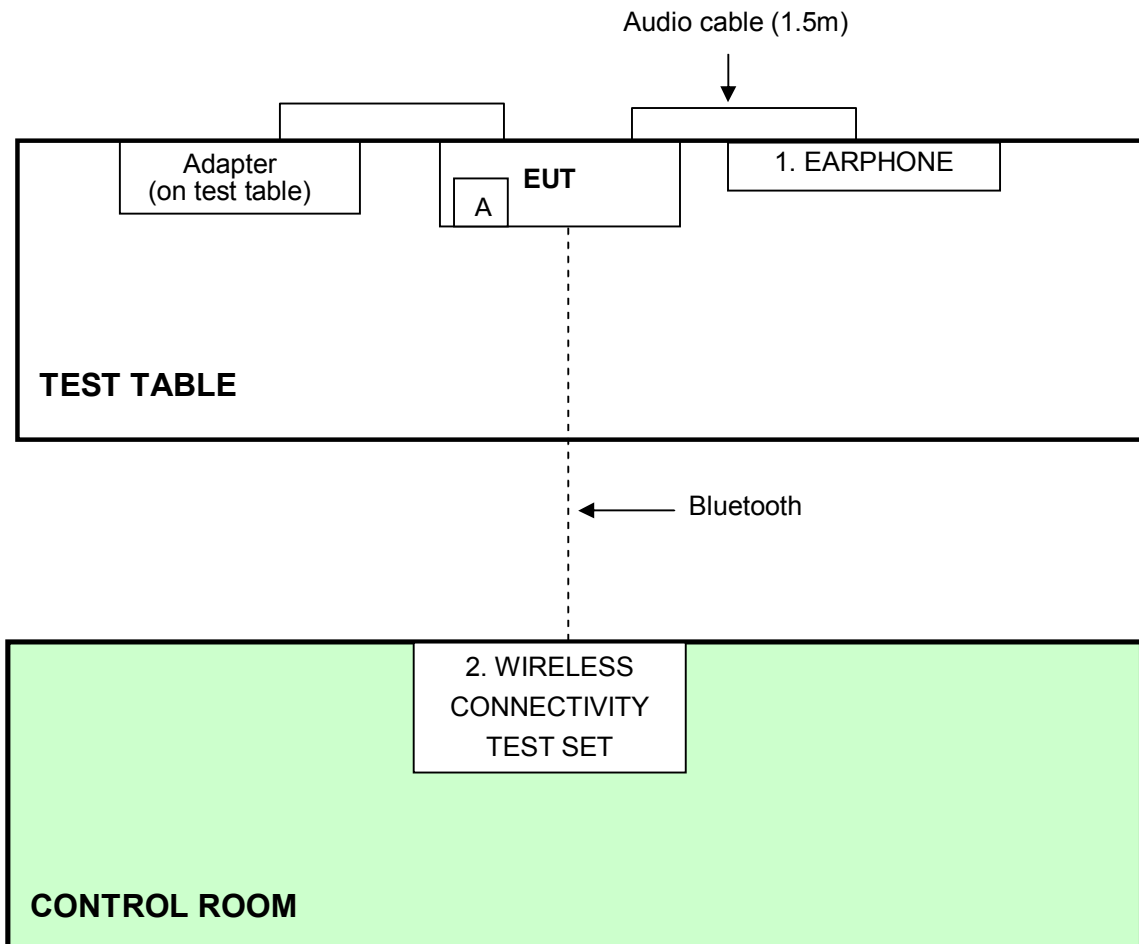

NOTE: 1. Item A is the SD Card.

4 TEST PROCEDURES AND RESULTS

4.1 CONDUCTED EMISSION MEASUREMENT

4.1.1 LIMITS OF CONDUCTED EMISSION MEASUREMENT

FREQUENCY OF EMISSION (MHz)	CONDUCTED LIMIT (dB μ V)	
	Quasi-peak	Average
0.15-0.5	66 to 56	56 to 46
0.5-5	56	46
5-30	60	50

NOTE:

1. The lower limit shall apply at the transition frequencies.
2. All emanations from a class B digital device or system, including any network of conductors and apparatus connected thereto, shall not exceed the level of field strengths specified above.

4.1.2 TEST INSTRUMENTS

Test Date: May 24

DESCRIPTION & MANUFACTURER	MODEL NO.	SERIAL NO.	CALIBRATED DATE	CALIBRATED UNTIL
ROHDE & SCHWARZ Test Receiver	ESCS 30	100287	Mar. 01, 2010	Feb. 28, 2011
Line-Impedance Stabilization Network (for EUT)	NSLK 8127	8127-523	Sep. 23, 2009	Sep. 22, 2010
Line-Impedance Stabilization Network (for Peripheral)	ENV-216	100072	June 08, 2009	June 07, 2010
RF Cable (JYEBAO)	5DFB	COACAB-001	Dec. 14, 2009	Dec. 13, 2010
50 ohms Terminator	50	3	Oct. 28, 2009	Oct. 27, 2010
Software	BV ADT_Cond_V7.3.7	NA	NA	NA

Note:

1. The calibration interval of the above test instruments is 12 months and the calibrations are traceable to NML/ROC and NIST/USA.
2. The test was performed in Shielded Room No. A.
3. The VCCI Con A Registration No. is C-817.

4.1.3 TEST PROCEDURES

- a. The EUT/HOST was placed 0.4 meters from the conducting wall of the shielded room with EUT/HOST being connected to the power mains through a line impedance stabilization network (LISN). Other support units were connected to the power mains through another LISN. The two LISNs provide 50 ohm/ 50uH of coupling impedance for the measuring instrument.
- b. Both lines of the power mains connected to the EUT/HOST were checked for maximum conducted interference.
- c. The frequency range from 150 kHz to 30 MHz was searched. Emission levels over 10dB under the prescribed limits could not be reported

4.1.4 TEST SETUP

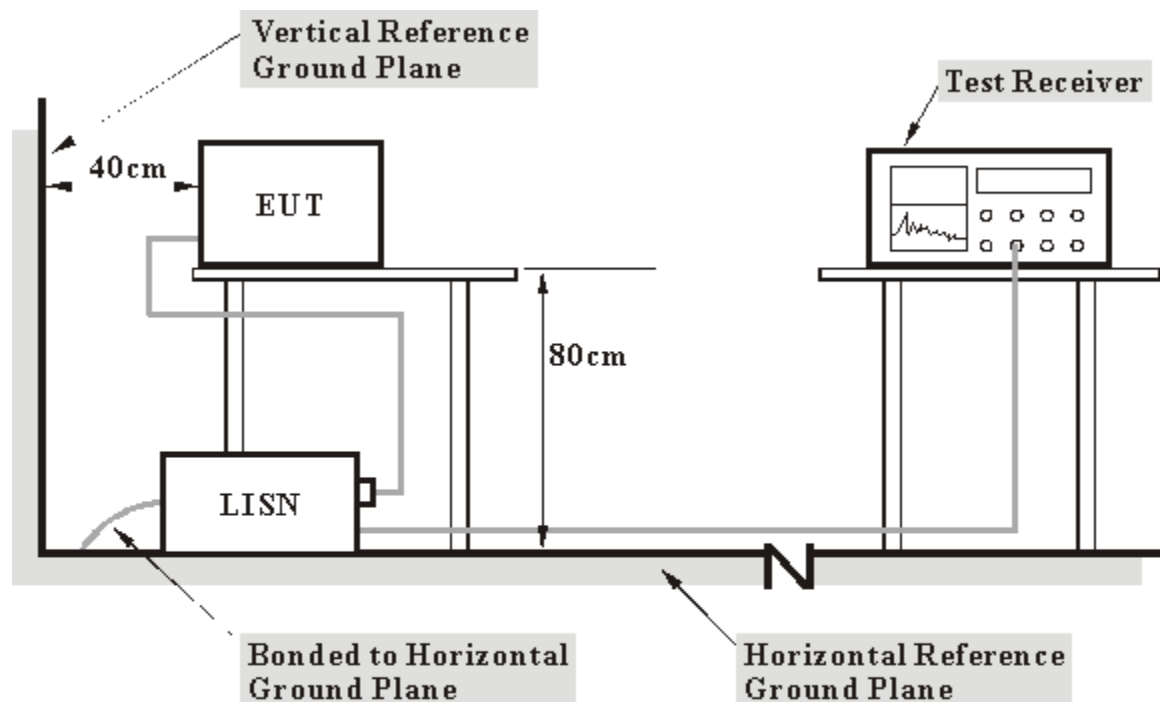

- Note:**
1. Support units were connected to second LISN.
 2. Both of LISNs (AMN) 80 cm from EUT and at the least 80 cm from other units and other metal planes support units.

For the actual test configuration, please refer to the related item – Photographs of the Test Configuration.

4.1.5 EUT OPERATING CONDITIONS

1. Turn on the power of all equipment.
2. Plug the SD card into EUT, EUT reads messages from SD card.
3. The support unit 1 (Notebook computer) sends messages to EUT via bluetooth transmission condition continuously.



A D T

4.1.6 TEST RESULTS

PHASE	Line (L)	6DB BANDWIDTH	9 kHz
--------------	----------	----------------------	-------

No	Freq.	Corr.	Reading Value		Emission Level		Limit		Margin	
	[MHz]	(dB)	Q.P.	AV.	Q.P.	AV.	Q.P.	AV.	Q.P.	AV.
1	0.150	0.03	53.70	-	53.73	-	66.00	56.00	-12.27	-
2	0.185	0.04	49.41	-	49.45	-	64.25	54.25	-14.80	-
3	0.373	0.05	40.86	-	40.91	-	58.44	48.44	-17.53	-
4	0.396	0.05	40.81	-	40.86	-	57.93	47.93	-17.08	-
5	0.509	0.08	41.65	-	41.73	-	56.00	46.00	-14.27	-
6	0.943	0.19	33.93	-	34.12	-	56.00	46.00	-21.88	-

- REMARKS:**
1. Q.P. and AV. are abbreviations of quasi-peak and average individually.
 2. "-": The Quasi-peak reading value also meets average limit and measurement with the average detector is unnecessary.
 3. The emission levels of other frequencies were very low against the limit.
 4. Margin value = Emission level - Limit value
 5. Correction factor = Insertion loss + Cable loss
 6. Emission Level = Correction Factor + Reading Value.

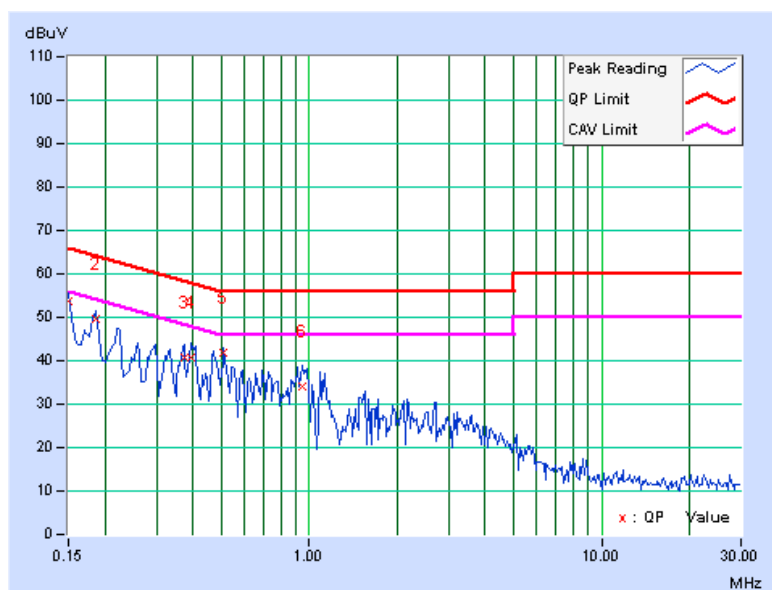

PHASE	Neutral (N)	6DB BANDWIDTH	9 kHz
--------------	-------------	----------------------	-------

No	Freq.	Corr.	Reading Value		Emission Level		Limit		Margin	
	[MHz]	Factor (dB)	Q.P.	AV.	Q.P.	AV.	Q.P.	AV.	Q.P.	AV.
			[dB (uV)]		[dB (uV)]		[dB (uV)]		(dB)	
1	0.150	0.04	51.99	-	52.03	-	66.00	56.00	-13.97	-
2	0.185	0.05	48.20	-	48.25	-	64.25	54.25	-16.00	-
3	0.408	0.06	39.72	-	39.78	-	57.69	47.69	-17.91	-
4	0.517	0.09	37.32	-	37.41	-	56.00	46.00	-18.59	-
5	0.591	0.11	33.83	-	33.94	-	56.00	46.00	-22.06	-
6	0.998	0.22	33.00	-	33.22	-	56.00	46.00	-22.78	-

- REMARKS:**
1. Q.P. and AV. are abbreviations of quasi-peak and average individually.
 2. "-": The Quasi-peak reading value also meets average limit and measurement with the average detector is unnecessary.
 3. The emission levels of other frequencies were very low against the limit.
 4. Margin value = Emission level - Limit value
 5. Correction factor = Insertion loss + Cable loss
 6. Emission Level = Correction Factor + Reading Value.

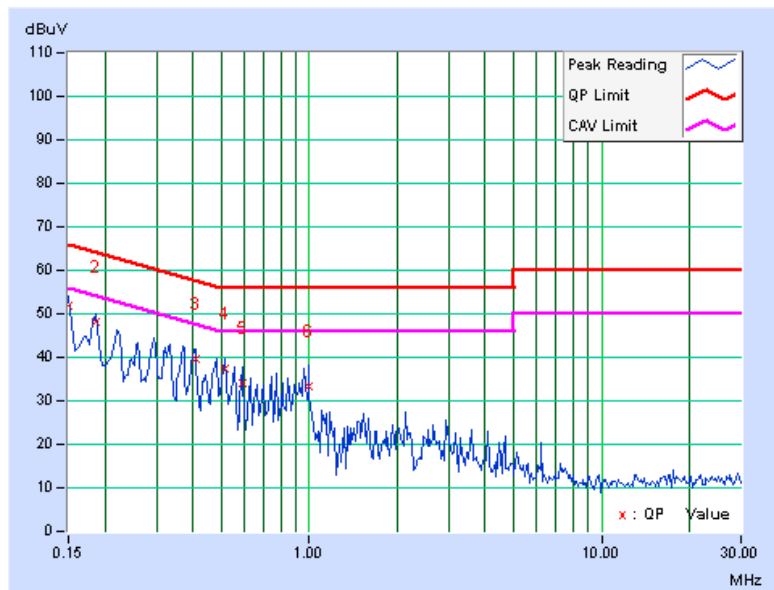

4.2 NUMBER OF HOPPING FREQUENCY USED

4.2.1 LIMIT OF HOPPING FREQUENCY USED

At least 15 hopping frequencies, and should be equally spaced.

4.2.2 TEST INSTRUMENTS

DESCRIPTION & MANUFACTURER	MODEL NO.	SERIAL NO.	CALIBRATED DATE	CALIBRATED UNTIL
Spectrum Analyzer	E4446A	MY48250253	Aug. 03, 2009	Aug. 02, 2010

NOTE:

1. The calibration interval of the above test instruments is 12 months and the calibrations are traceable to NML/ROC and NIST/USA.

4.2.3 TEST PROCEDURES

1. Check the calibration of the measuring instrument (SA) using either an internal calibrator or a known signal from an external generator.
2. Turn on the EUT and connect its antenna terminal to measurement via a low loss cable. Then set it to any one measured frequency within its operating range and make sure the instrument is operated in its linear range.
3. Set the SA on MaxHold Mode, and then keep the EUT in hopping mode. Record all the signals from each channel until each one has been recorded.
4. Set the SA on View mode and then plot the result on SA screen.
5. Repeat above procedures until all frequencies measured were complete.

4.2.4 DEVIATION FROM TEST STANDARD

No deviation

4.2.5 TEST SETUP

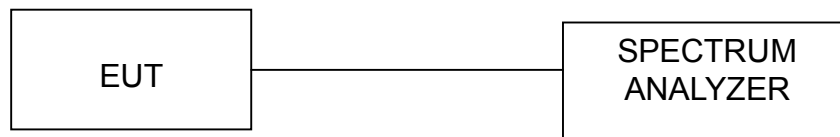

4.2.6 TEST RESULTS

There are 79 hopping frequencies in the hopping mode. Please refer to next pages for the test result. On the plots, it shows that the hopping frequencies are equally spaced.



A D T

For GFSK:

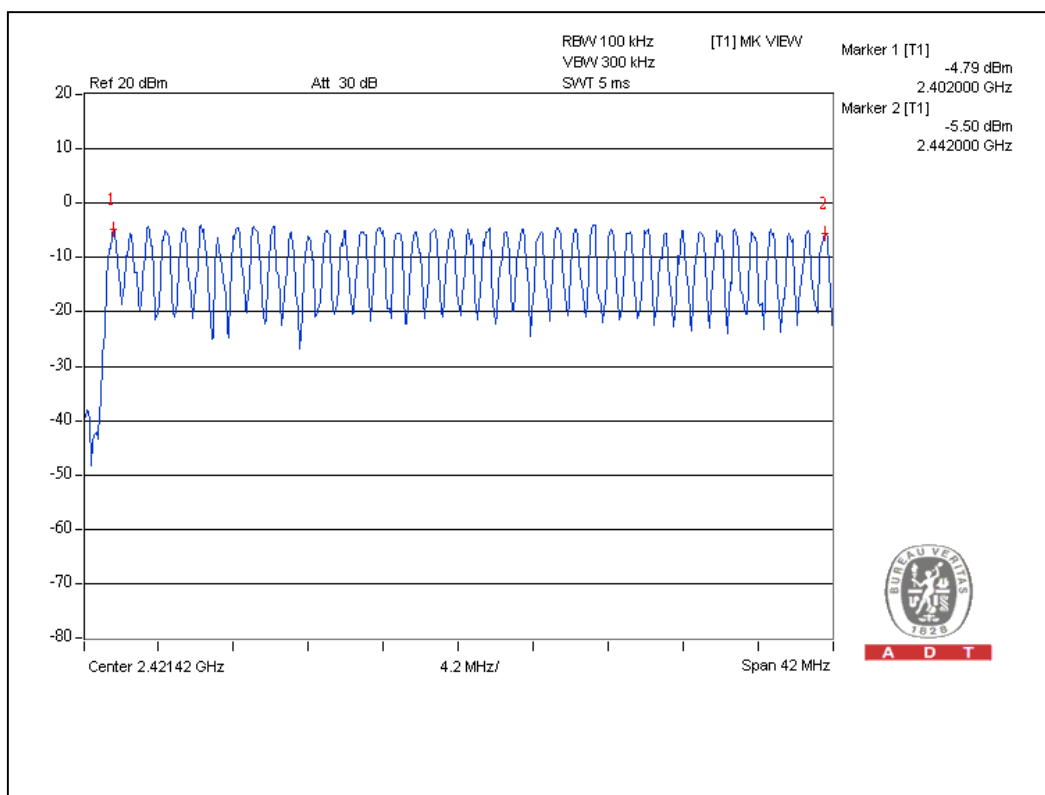

A D T

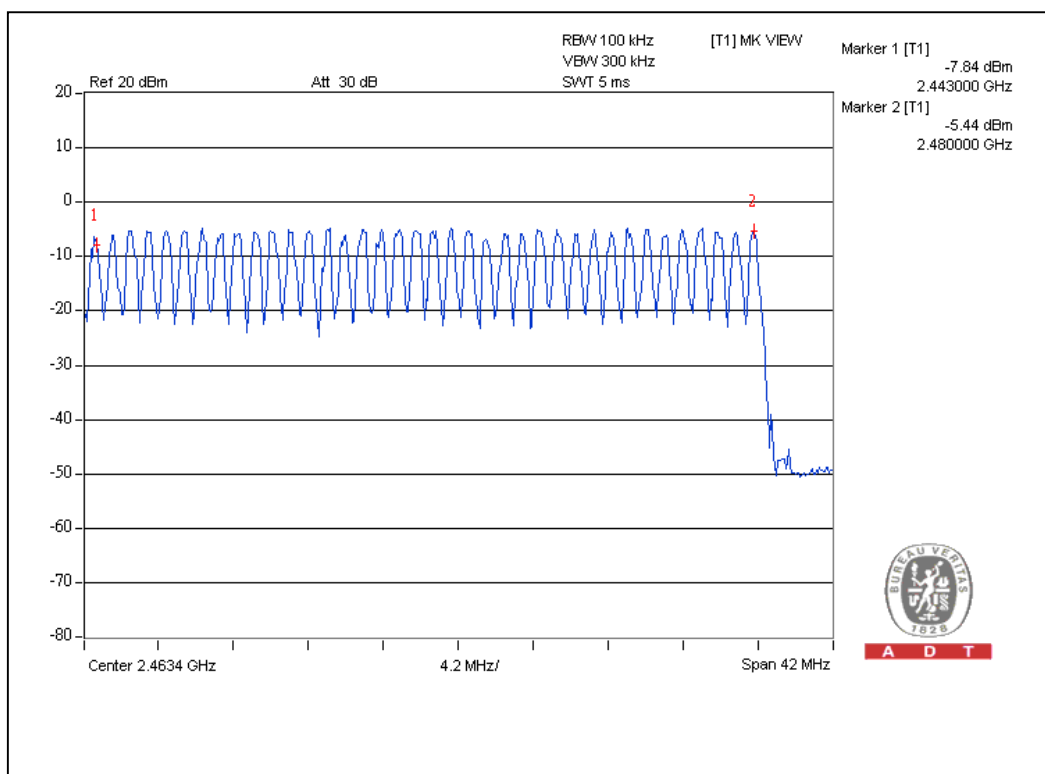

A D T



A D T

For 8DPSK:

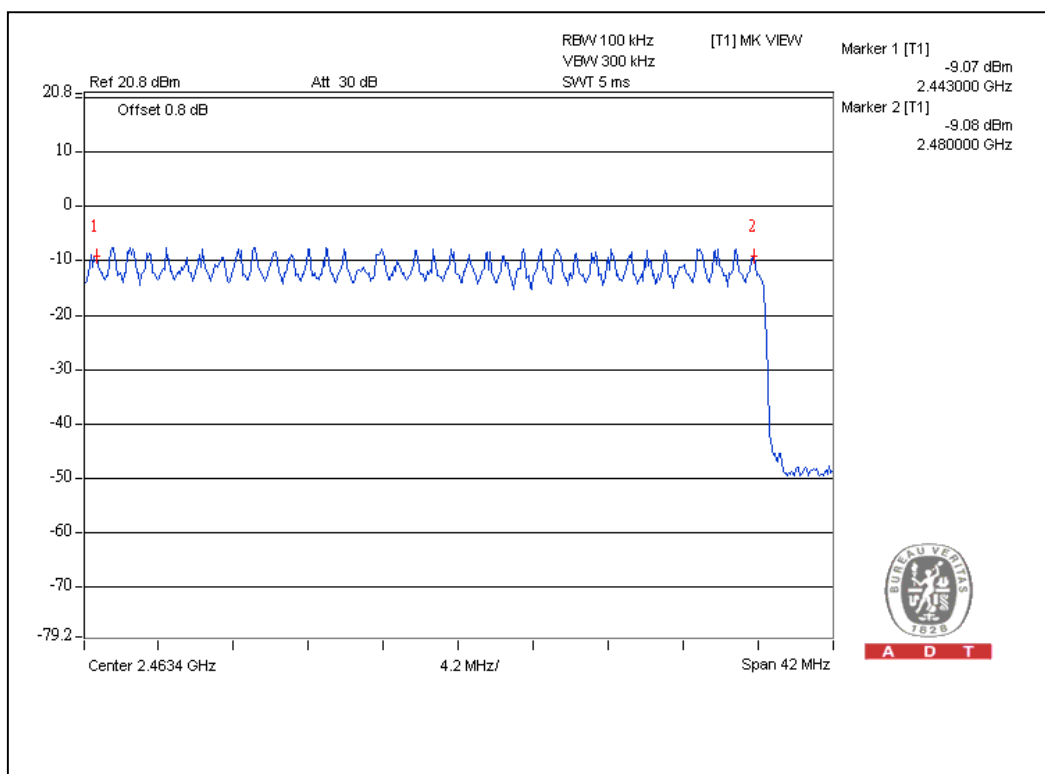
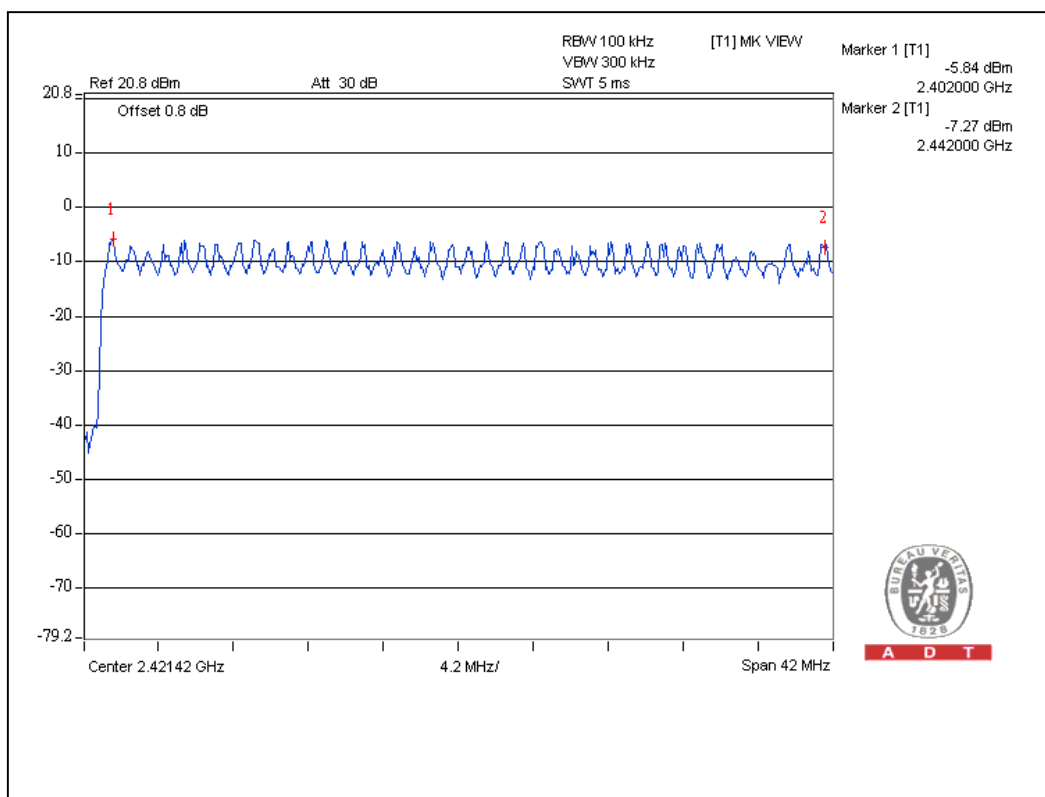



A D T

For $\pi/4$ -DQPSK :

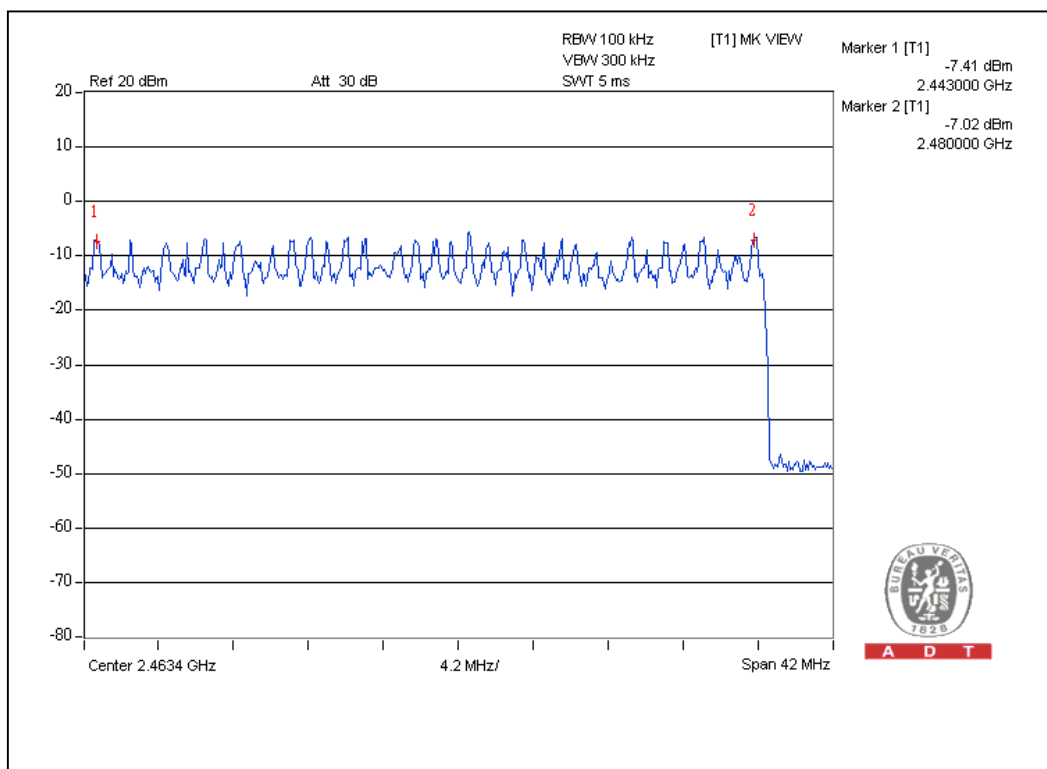
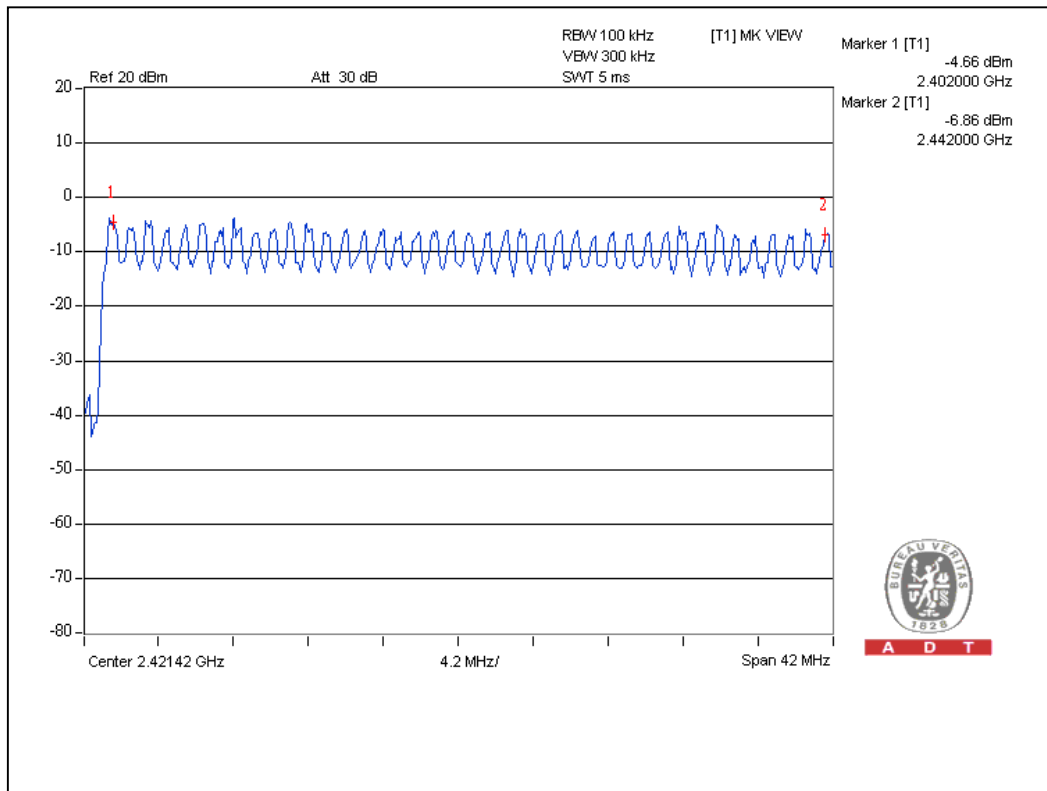

4.3 DWELL TIME ON EACH CHANNEL

4.3.1 LIMIT OF DWELL TIME USED

For FHSS, the average time of occupancy on any frequency shall not be greater than 0.4 seconds within a 31.6 second period. For hybrid systems, the average time of occupancy on any frequency should not exceed 0.4 seconds within a time period in seconds equal to the number of hopping frequencies employed multiplied by 0.4.

4.3.2 TEST INSTRUMENTS

DESCRIPTION & MANUFACTURER	MODEL NO.	SERIAL NO.	CALIBRATED DATE	CALIBRATED UNTIL
Spectrum Analyzer	E4446A	MY48250253	Aug. 03, 2009	Aug. 02, 2010

NOTE:

1. The calibration interval of the above test instruments is 12 months and the calibrations are traceable to NML/ROC and NIST/USA.

4.3.3 TEST PROCEDURES

1. Check the calibration of the measuring instrument (SA) using either an internal calibrator or a known signal from an external generator.
2. Turn on the EUT and connect its antenna terminal to measurement via a low loss cable. Then set it to any one measured frequency within its operating range and make sure the instrument is operated in its linear range.
3. Adjust the center frequency of SA on any frequency be measured and set SA to zero span mode. And then, set RBW and VBW of spectrum analyzer to proper value.
4. Measure the time duration of one transmission on the measured frequency. And then plot the result with time difference of this time duration.
5. Repeat above procedures until all frequencies measured were complete.

4.3.4 DEVIATION FROM TEST STANDARD

No deviation

4.3.5 TEST SETUP

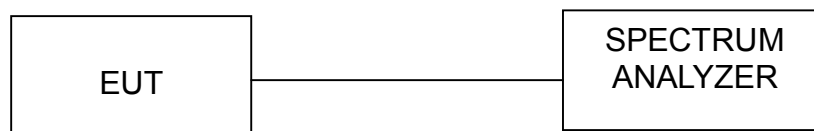

4.3.6 TEST RESULTS

For GFSK:

Mode	Number of transmission in a 31.6 (79Hopping*0.4)	Length of transmission time (msec)	Result (msec)	Limit (msec)
DH1	50 (times / 5 sec) *6.32=316 times	0.474	149.8	400
DH3	26 (times / 5 sec) *6.32=164.32 times	1.71	281.0	400
DH5	16 (times / 5 sec) *6.32=101.12 times	3.04	307.4	400

Test plots of the transmitting time slot are shown on next three pages.



A D T

DH1

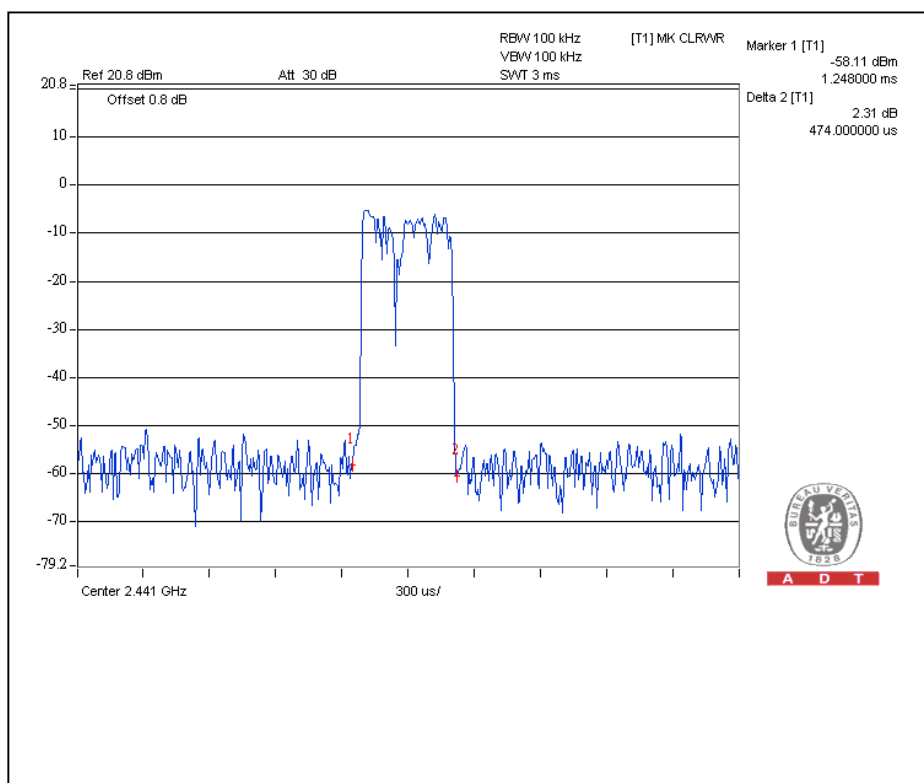
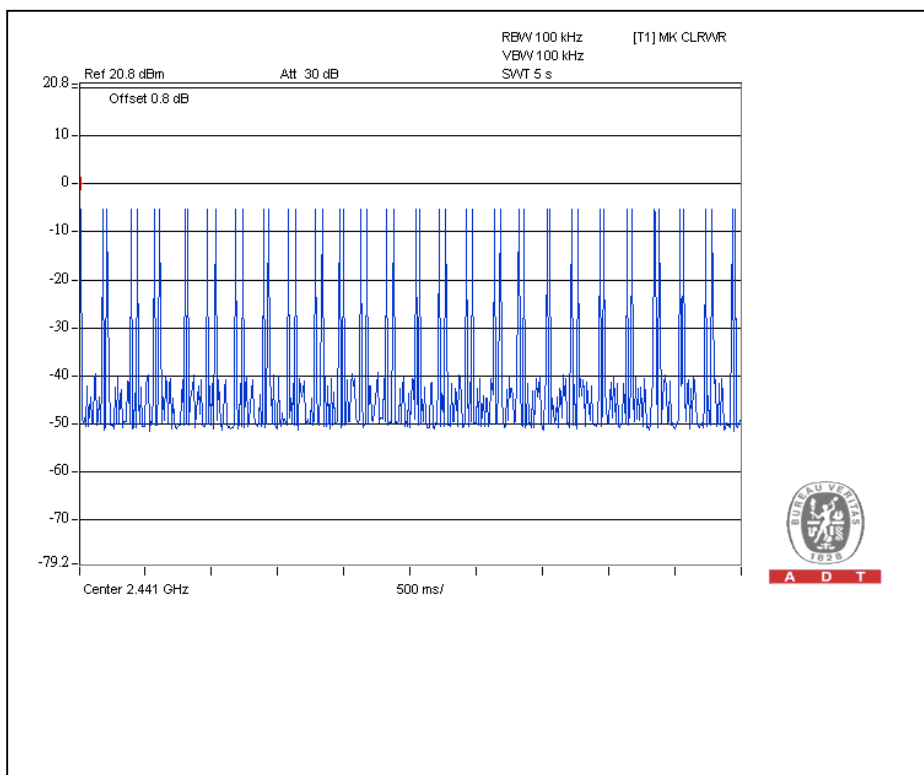



A D T

DH3

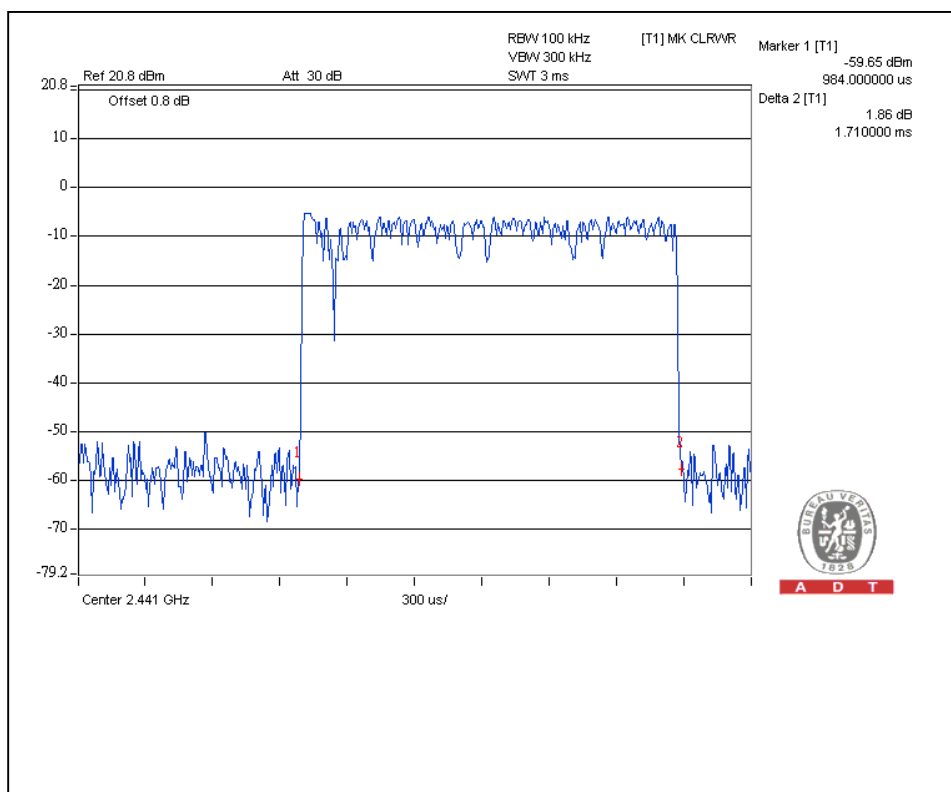
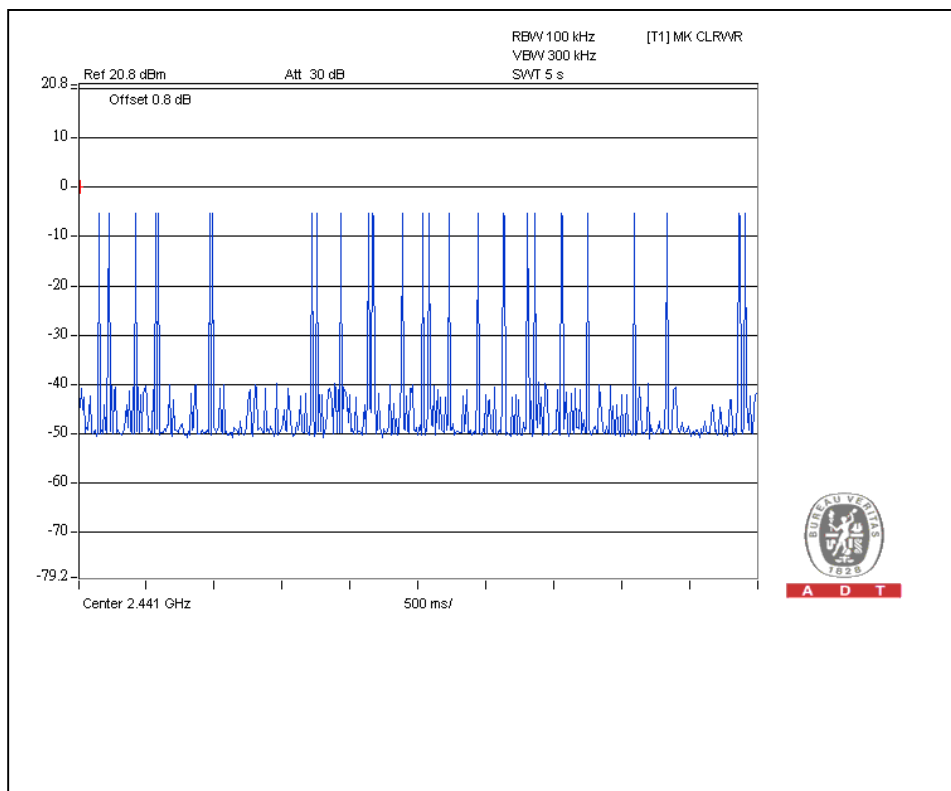



A D T

DH5

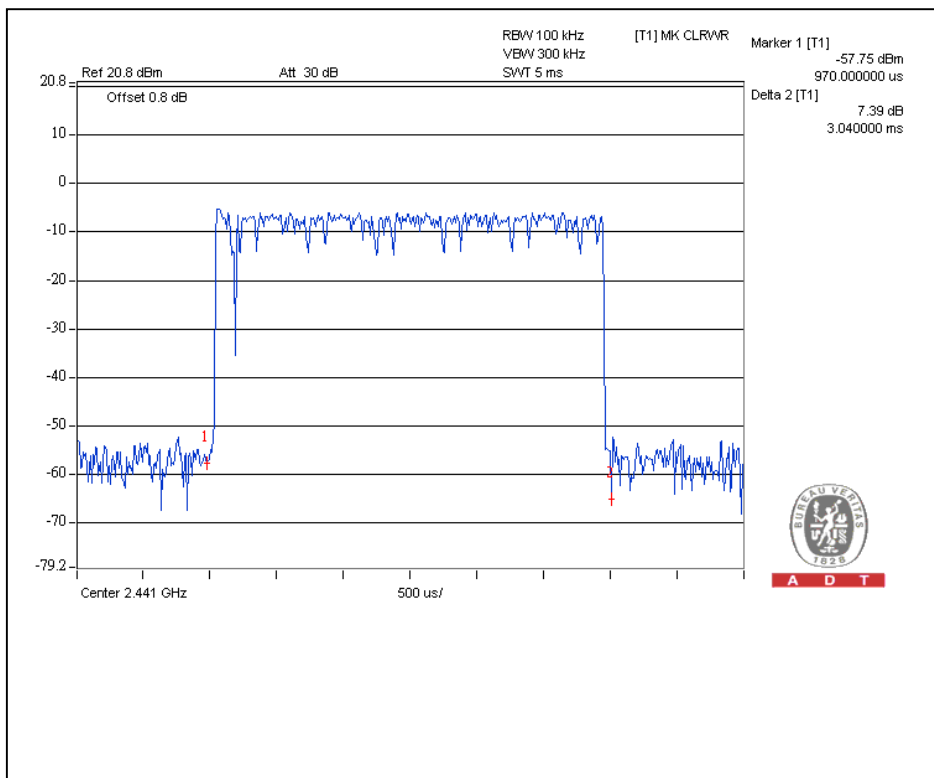
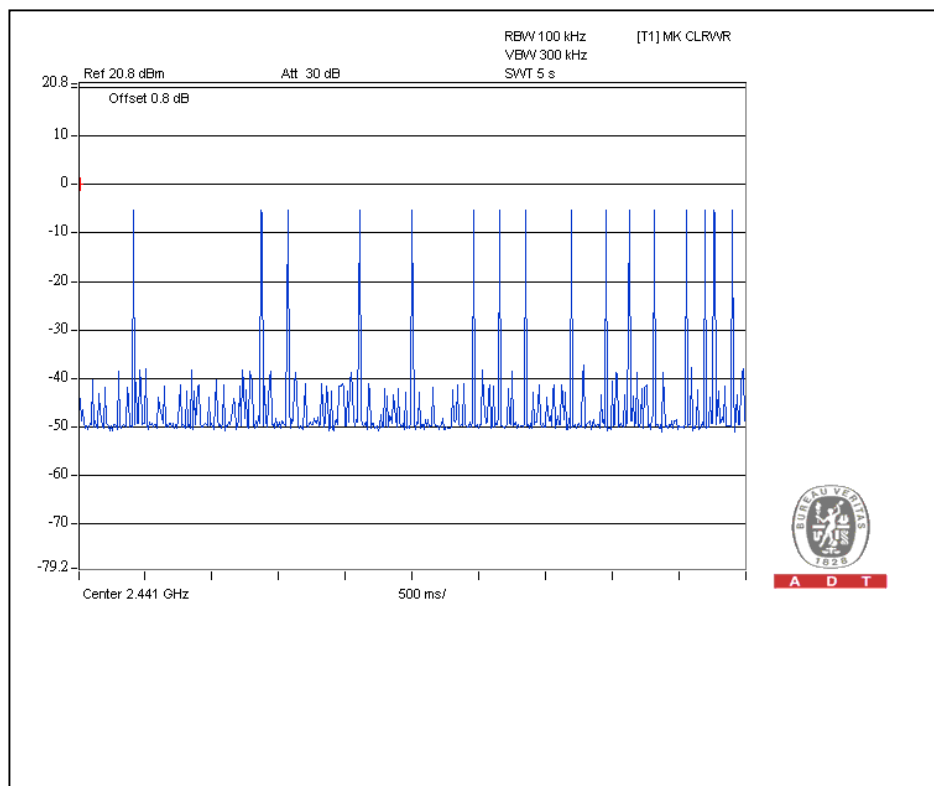



A D T

For 8DPSK :

Mode	Number of transmission in a 31.6 (79Hopping*0.4)	Length of transmission time (msec)	Result (msec)	Limit (msec)
DH1	50 (times / 5 sec) *6.32=316 times	0.480	151.7	400
DH3	25 (times / 5 sec) *6.32=158 times	1.716	271.1	400
DH5	16 (times / 5 sec) *6.32=101.12 times	2.99	302.3	400

Test plots of the transmitting time slot are shown on next three pages.



A D T

DH1

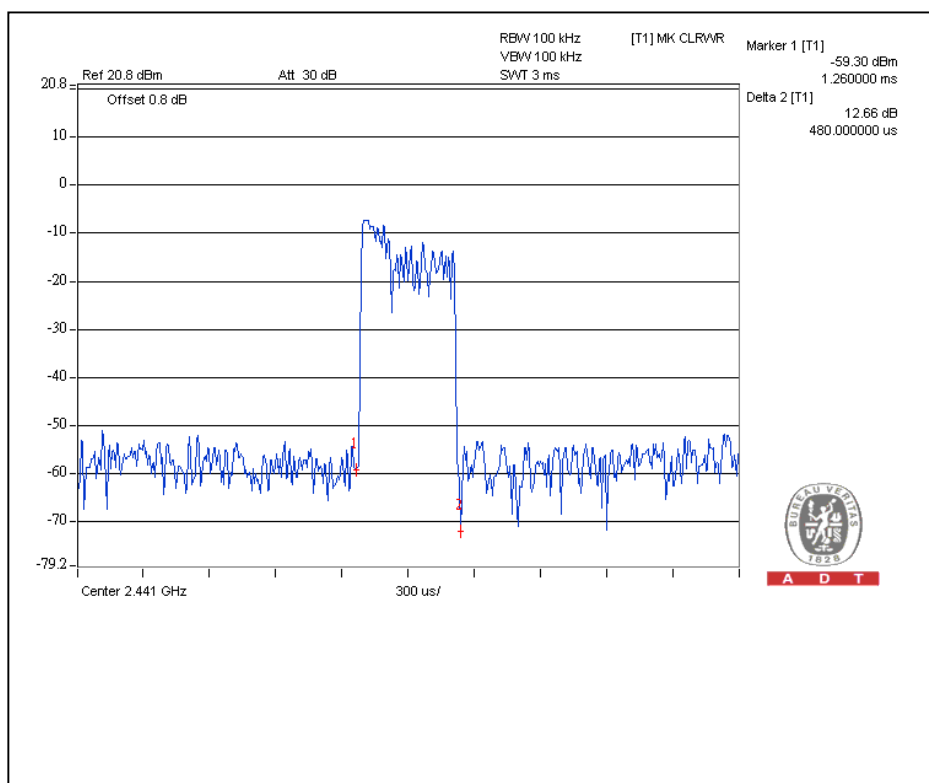
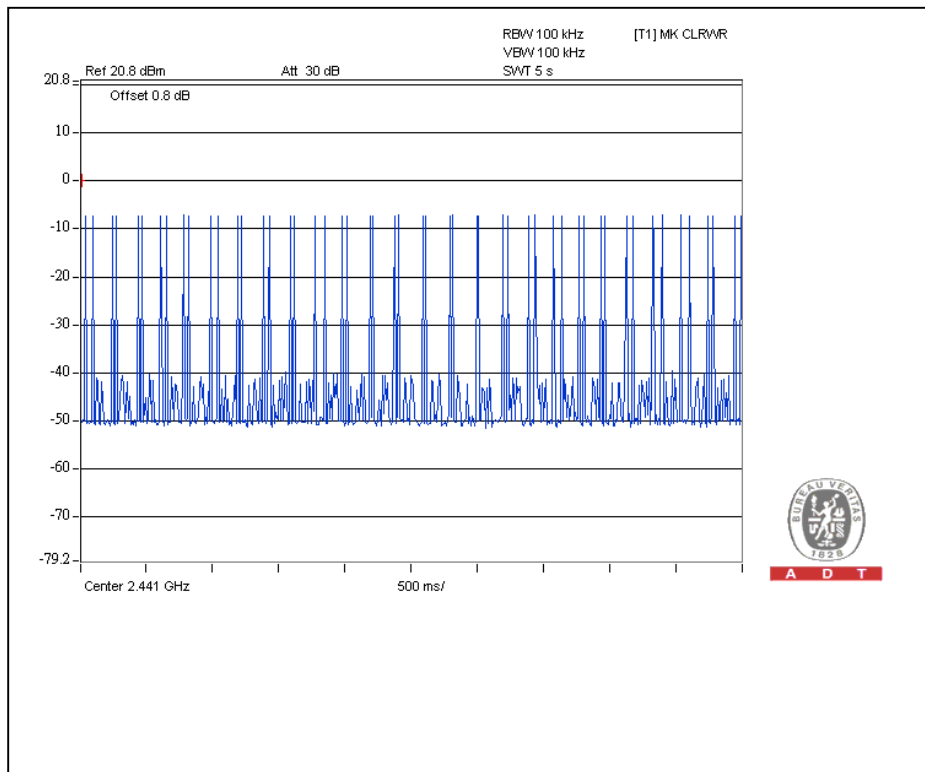



A D T

DH3

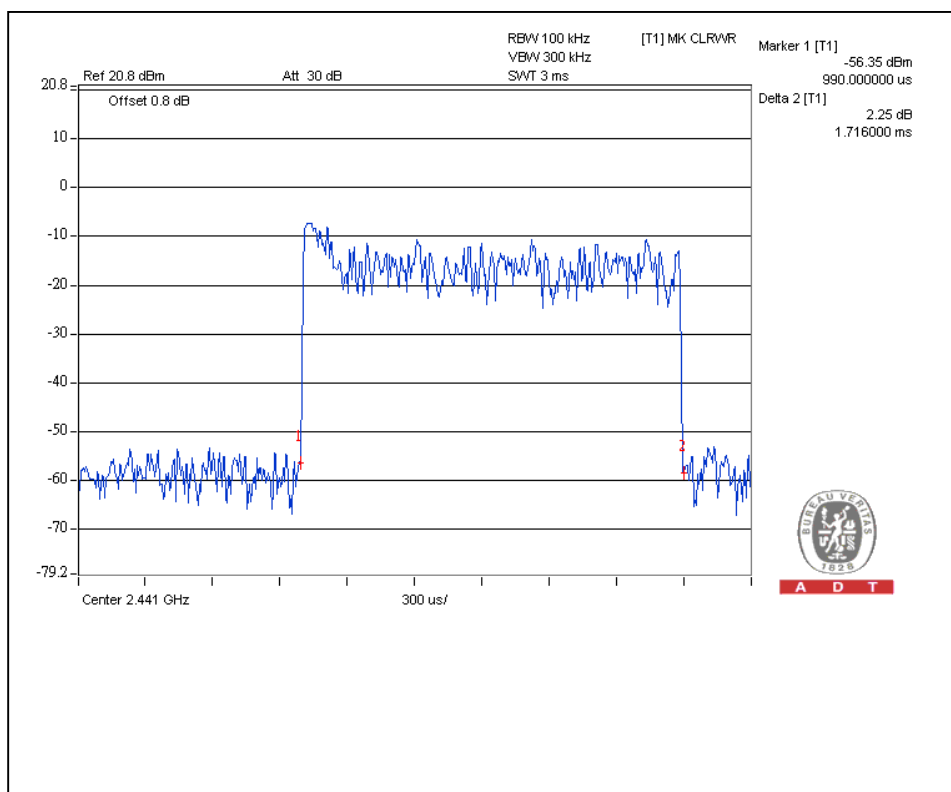
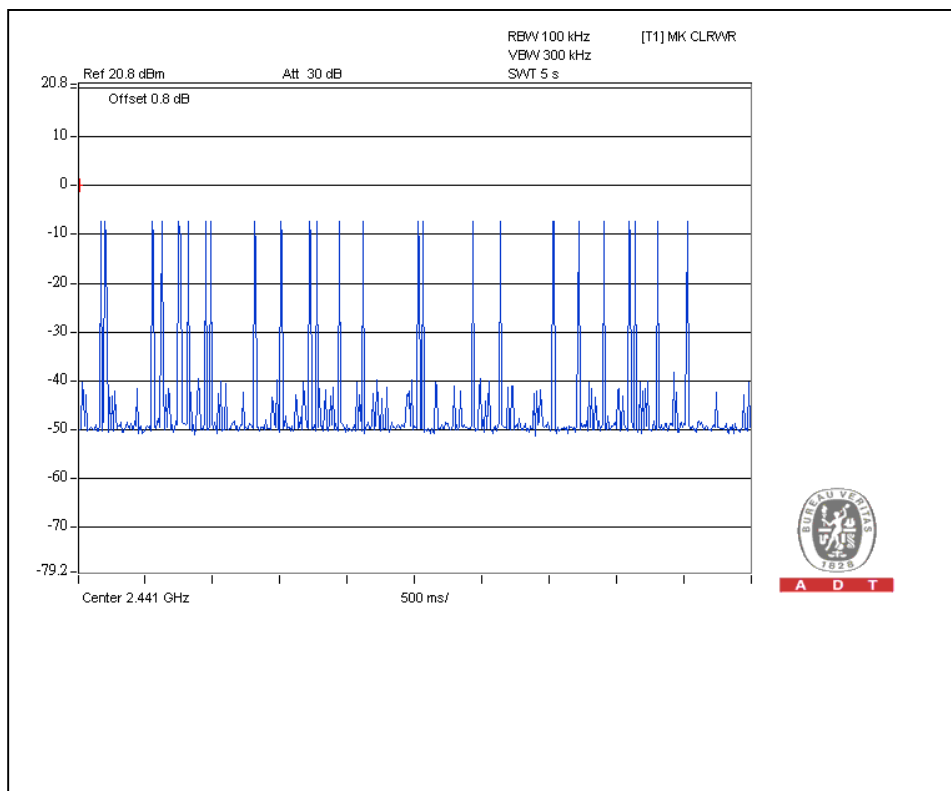



A D T

DH5

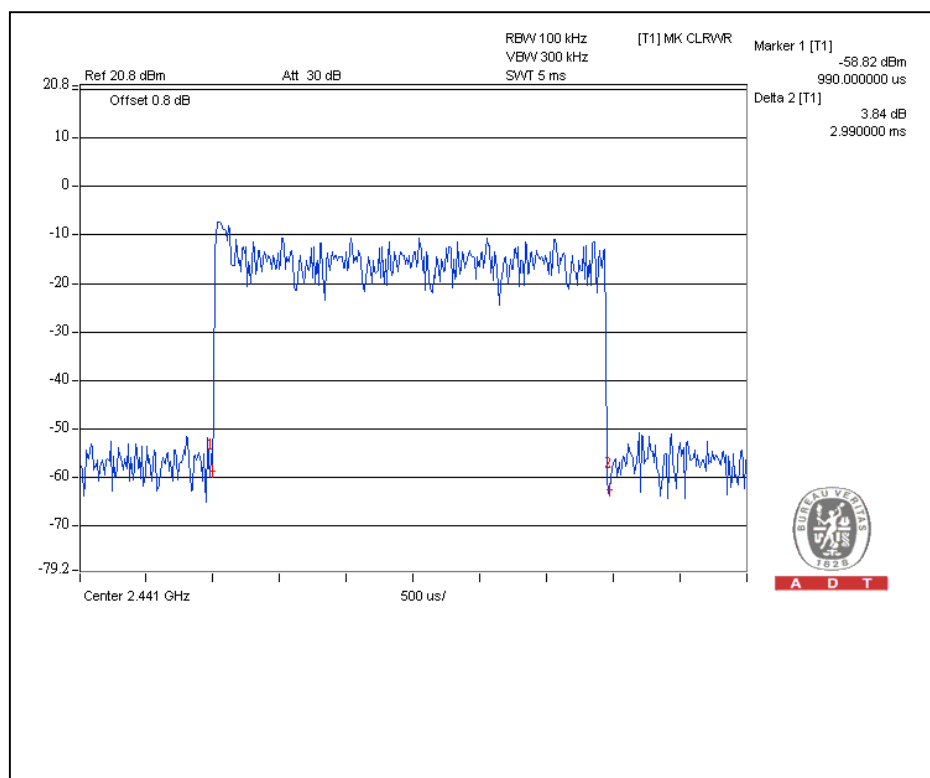
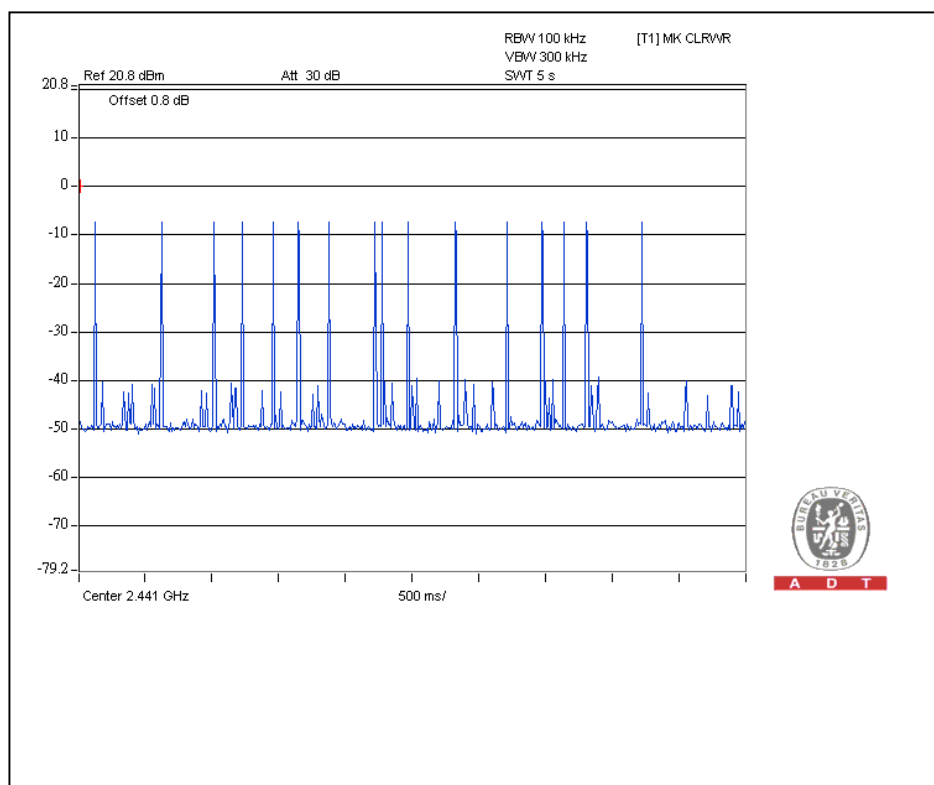



A D T

For $\pi/4$ – DQPSK :

Mode	Number of transmission in a 31.6 (79Hopping*0.4)	Length of transmission time (msec)	Result (msec)	Limit (msec)
DH1	50 (times / 5 sec) *6.32=316 times	0.474	149.8	400
DH3	25 (times / 5 sec) *6.32=158 times	1.716	271.1	400
DH5	18 (times / 5 sec) *6.32=113.76 times	2.98	339.0	400

Test plots of the transmitting time slot are shown on next three pages.



A D T

DH1

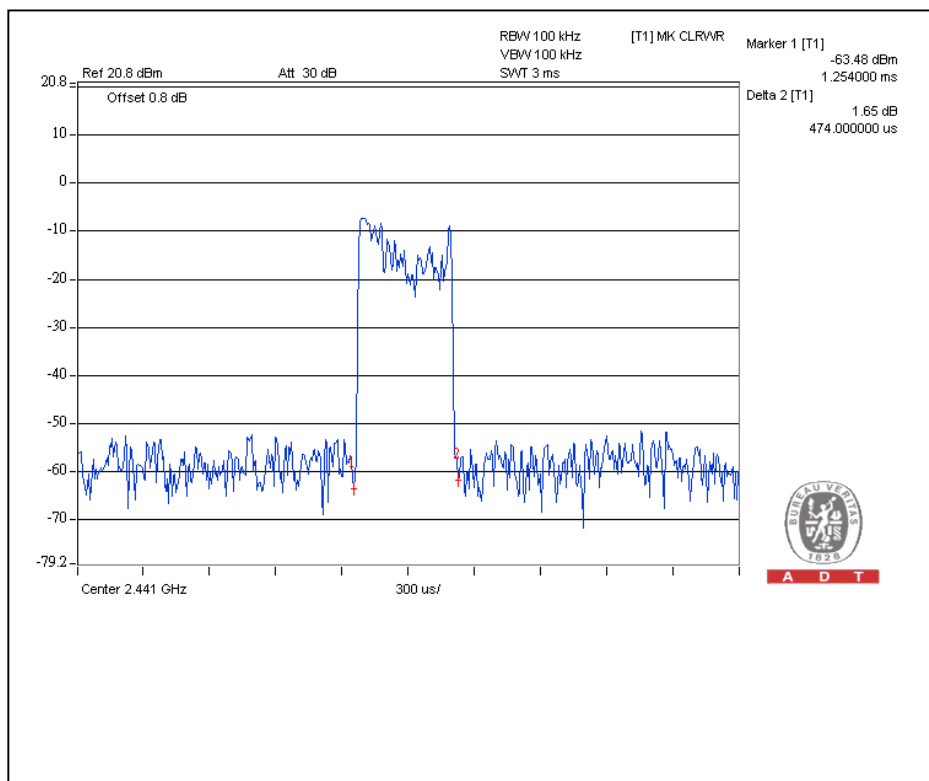
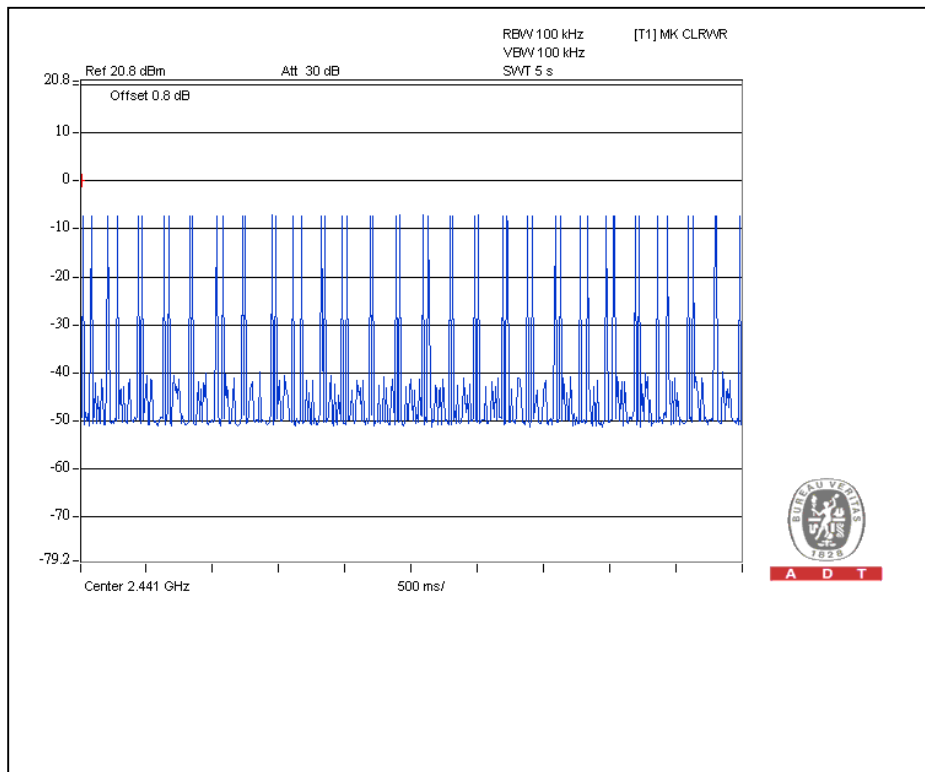



A D T

DH3

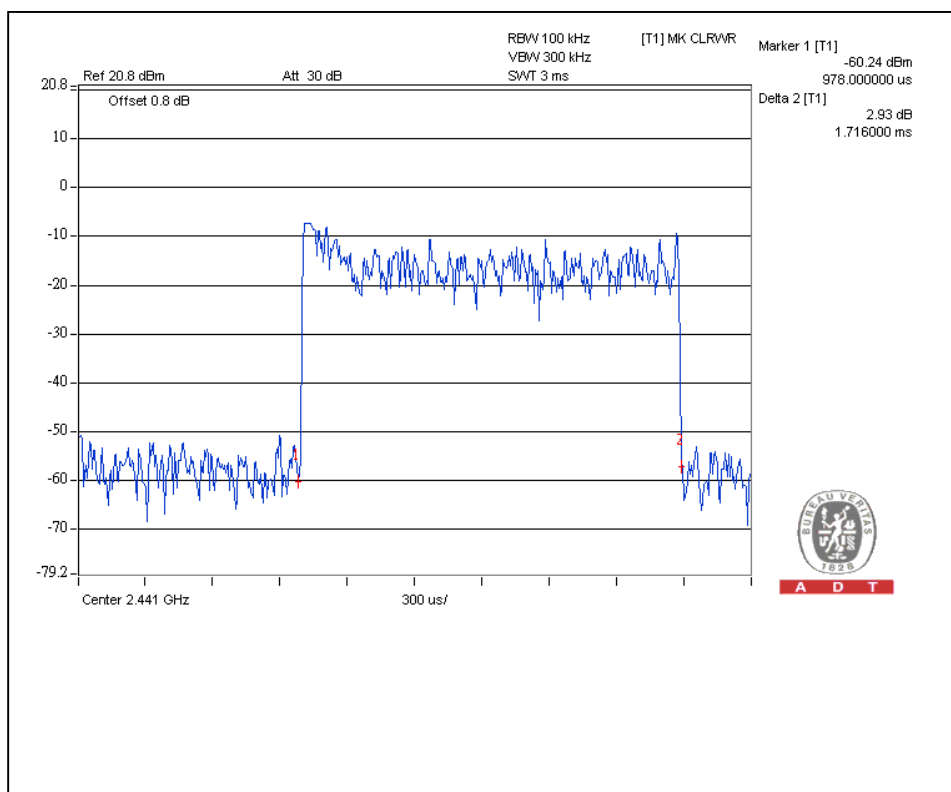
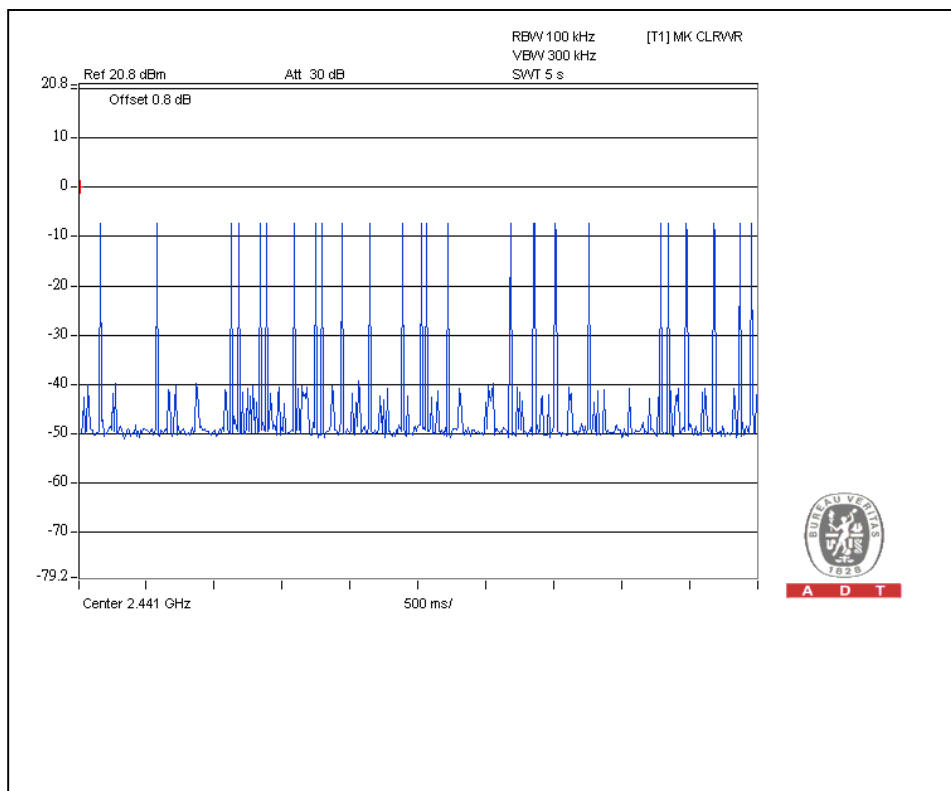



A D T

DH5

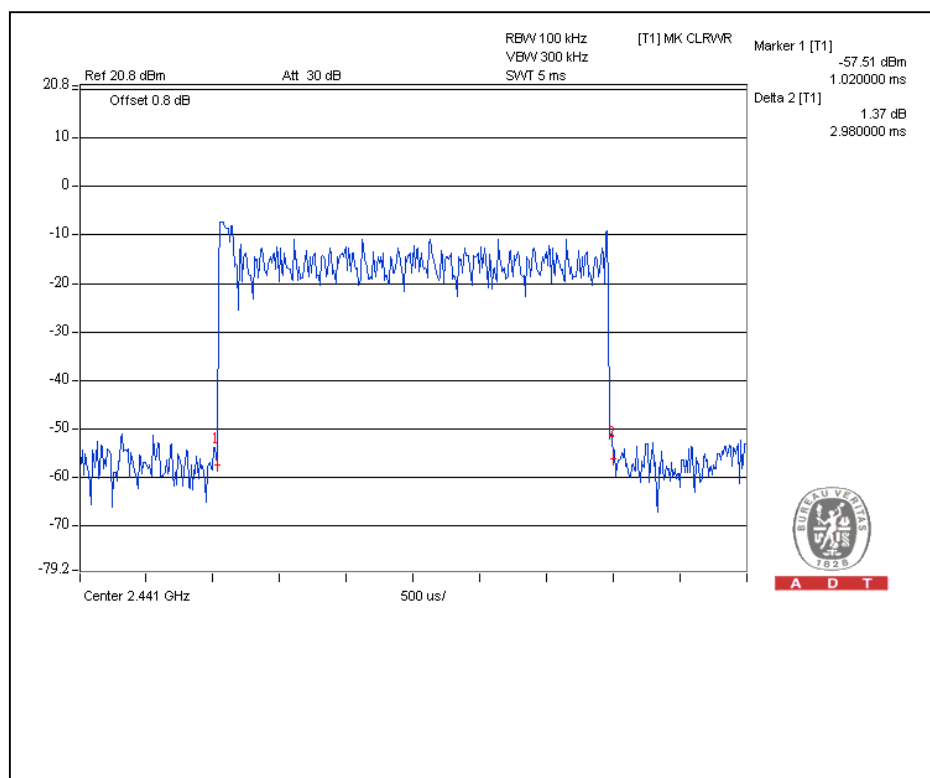
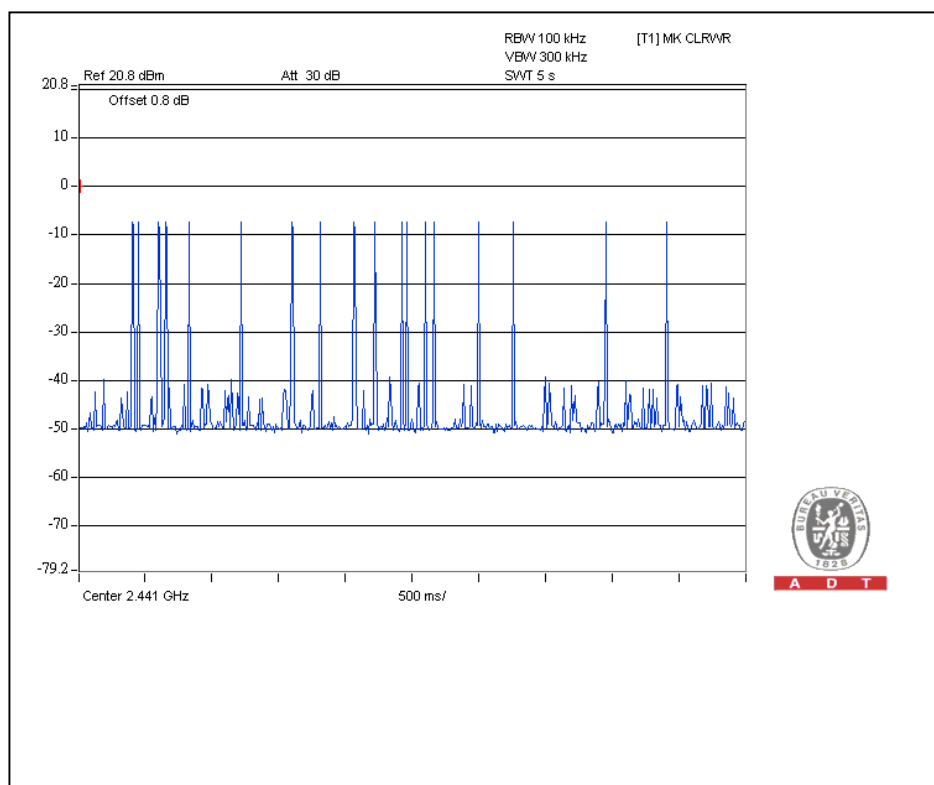

4.4 CHANNEL BANDWIDTH

4.4.1 LIMITS OF CHANNEL BANDWIDTH

For frequency hopping system operating in the 2400-2483.5MHz, If the two-thirds 20dB bandwidth of hopping channel is greater than 25kHz, two-thirds 20dB bandwidth of hopping channel shall be a minimum limit for the hopping channel separation.

4.4.2 TEST INSTRUMENTS

DESCRIPTION & MANUFACTURER	MODEL NO.	SERIAL NO.	CALIBRATED DATE	CALIBRATED UNTIL
Spectrum Analyzer	E4446A	MY48250253	Aug. 03, 2009	Aug. 02, 2010

NOTE: The calibration interval of the above test instruments is 12 months and the calibrations are traceable to NML/ROC and NIST/USA.

4.4.3 TEST PROCEDURE

1. Check the calibration of the measuring instrument using either an internal calibrator or a known signal from an external generator.
2. Turn on the EUT and connect it to measurement instrument. Then set it to any one convenient frequency within its operating range. Set a reference level on the measuring instrument equal to the highest peak value.
3. Measure the frequency difference of two frequencies that were attenuated 20dB from the reference level. Record the frequency difference as the emission bandwidth.
4. Repeat above procedures until all frequencies measured were complete.

4.4.4 DEVIATION FROM TEST STANDARD

No deviation

4.4.5 TEST SETUP

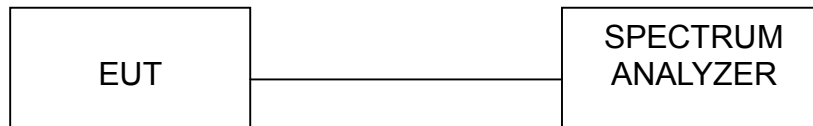

4.4.6 EUT OPERATING CONDITION

The software provided by client enabled the EUT to transmit and receive data at lowest, middle and highest channel frequencies individually.



A D T

4.4.7 TEST RESULTS

For GFSK:

CHANNEL	CHANNEL FREQUENCY (MHz)	20dB BANDWIDTH (MHz)
0	2402	0.95
39	2441	0.94
78	2480	0.94

Channel 0

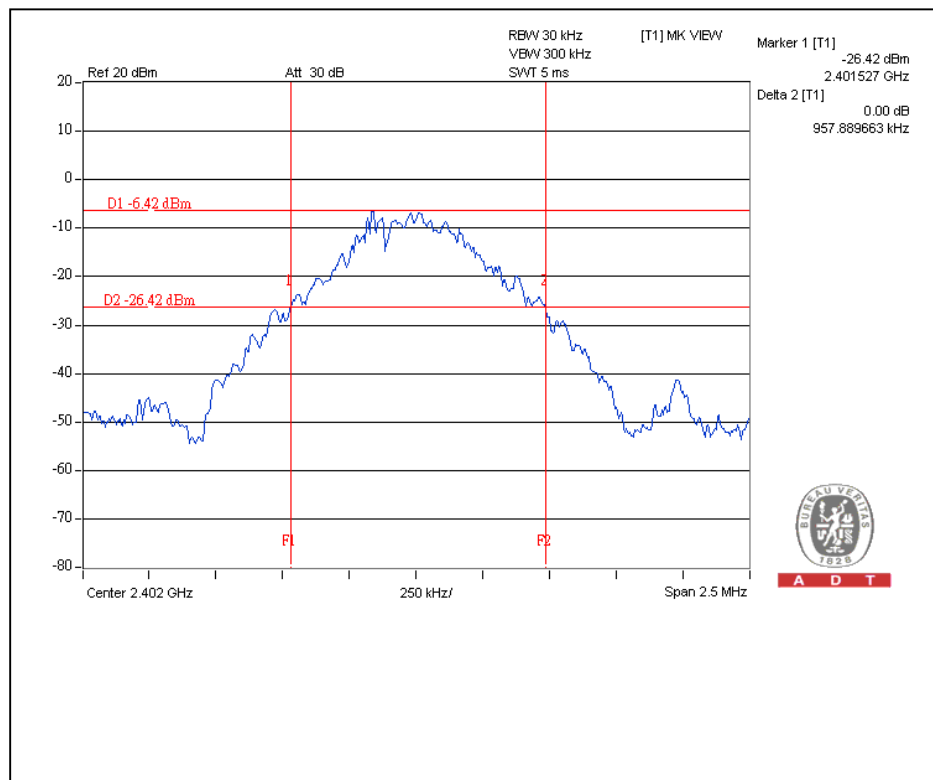



A D T

Channel 39

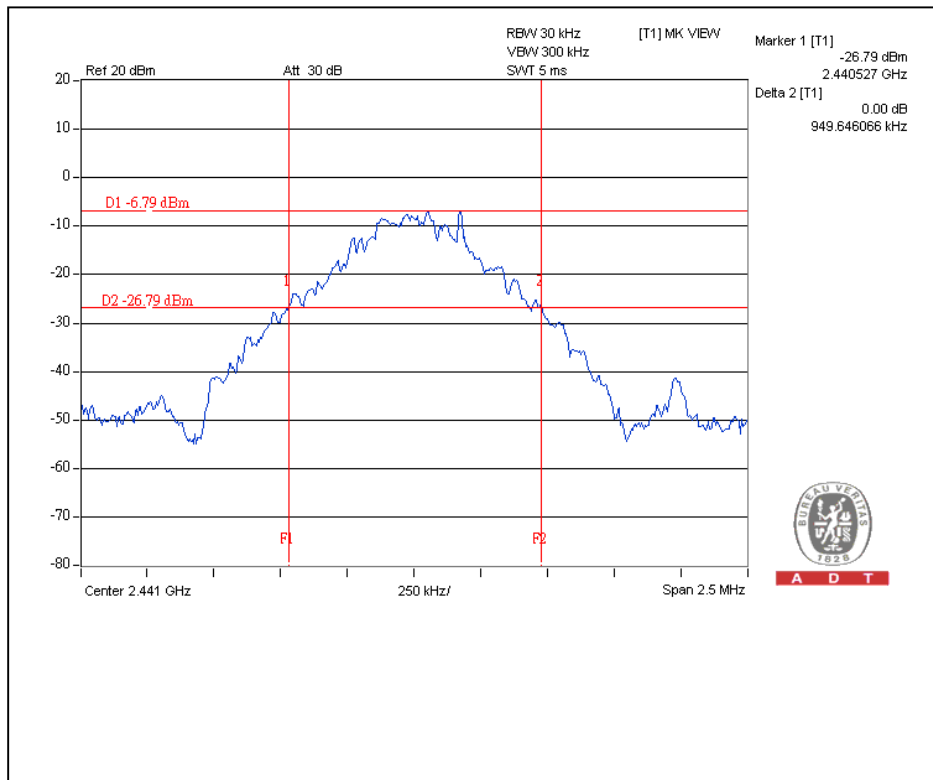

Channel 78

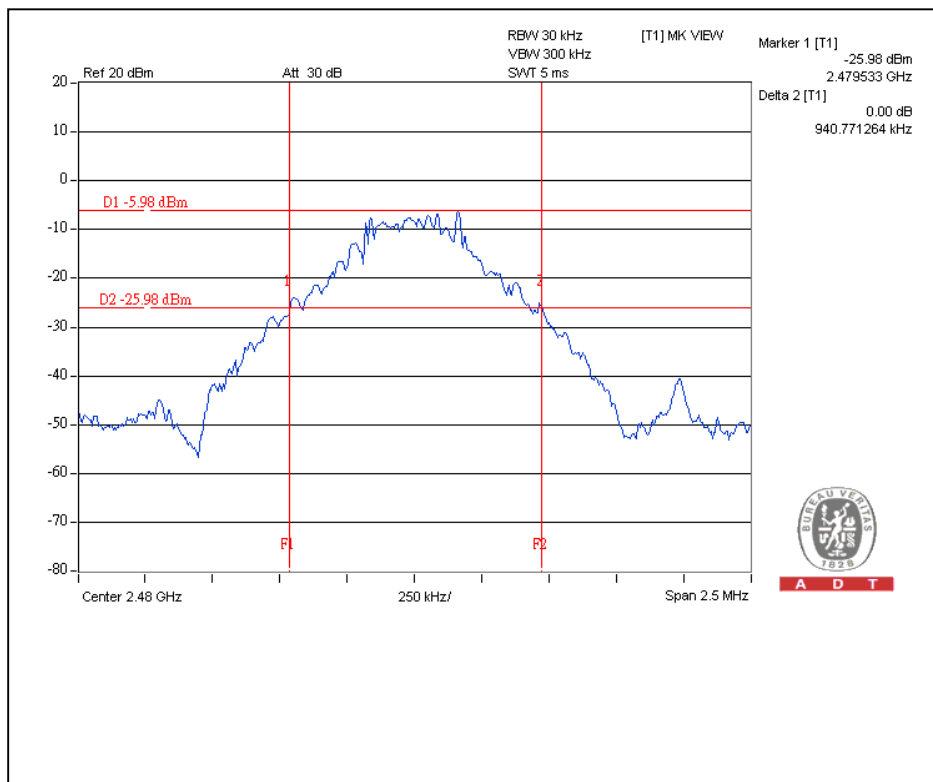



A D T

For 8DPSK:

CHANNEL	CHANNEL FREQUENCY (MHz)	20dB BANDWIDTH (MHz)
0	2402	1.26
39	2441	1.33
78	2480	1.23

Channel 0

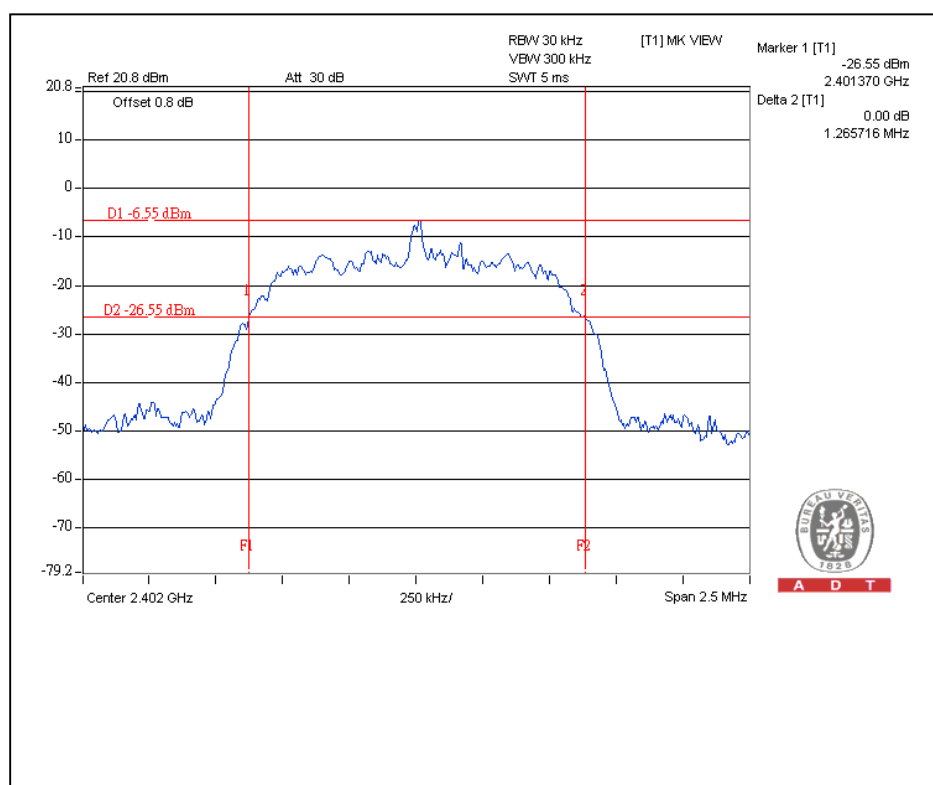



A D T

Channel 39

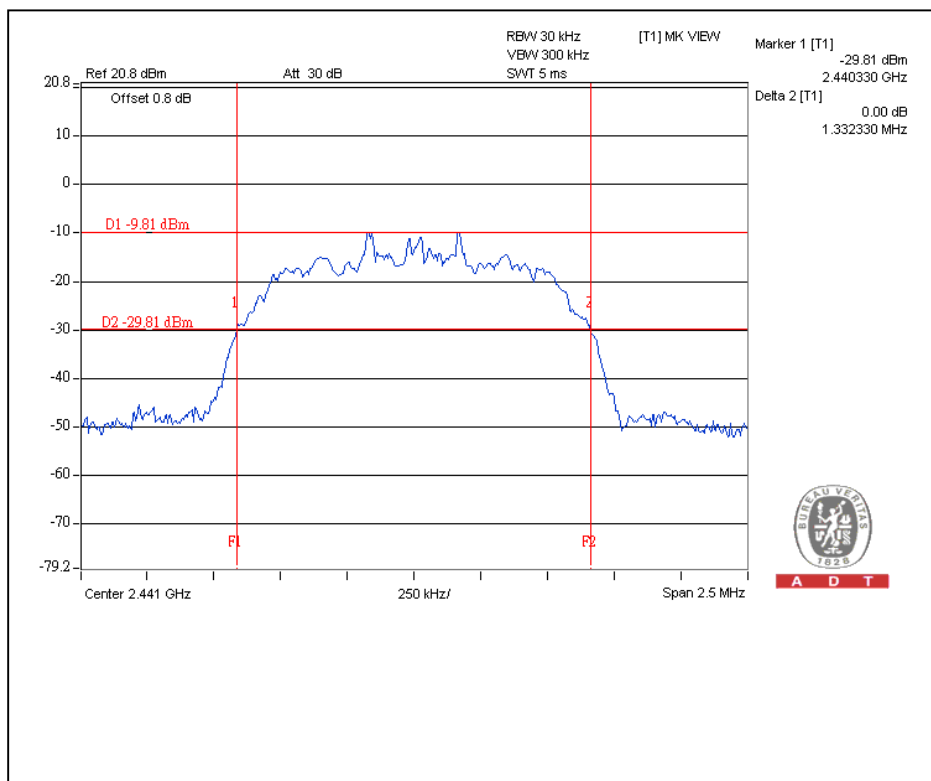

Channel 78

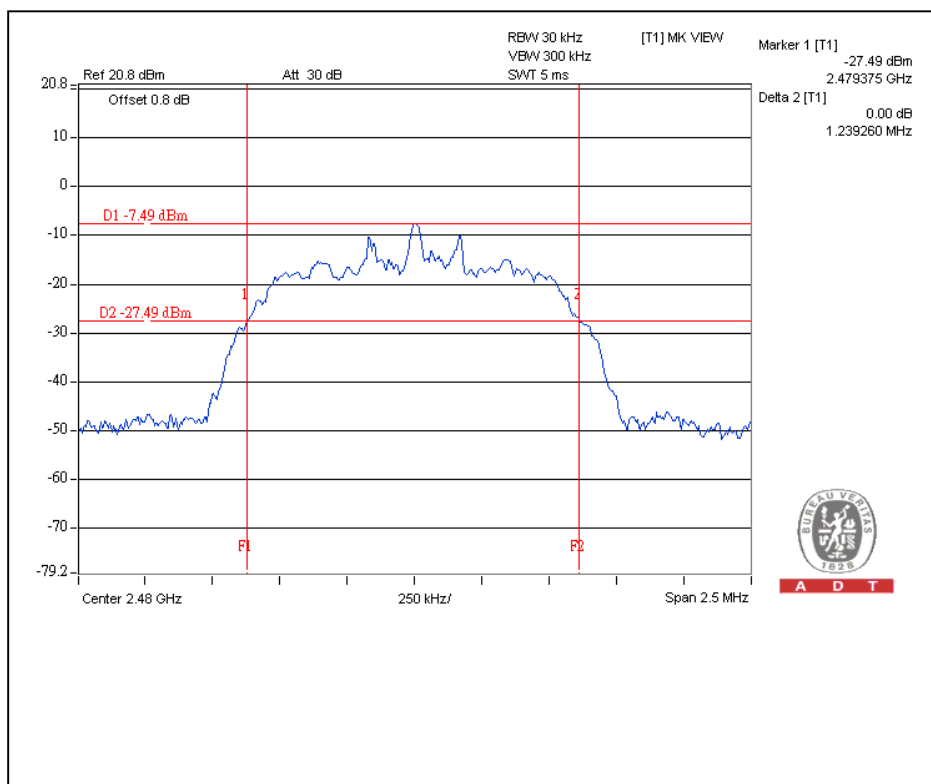



A D T

For $\pi/4$ -DQPSK:

CHANNEL	CHANNEL FREQUENCY (MHz)	20dB BANDWIDTH (MHz)
0	2402	1.25
39	2441	1.24
78	2480	1.24

Channel 0

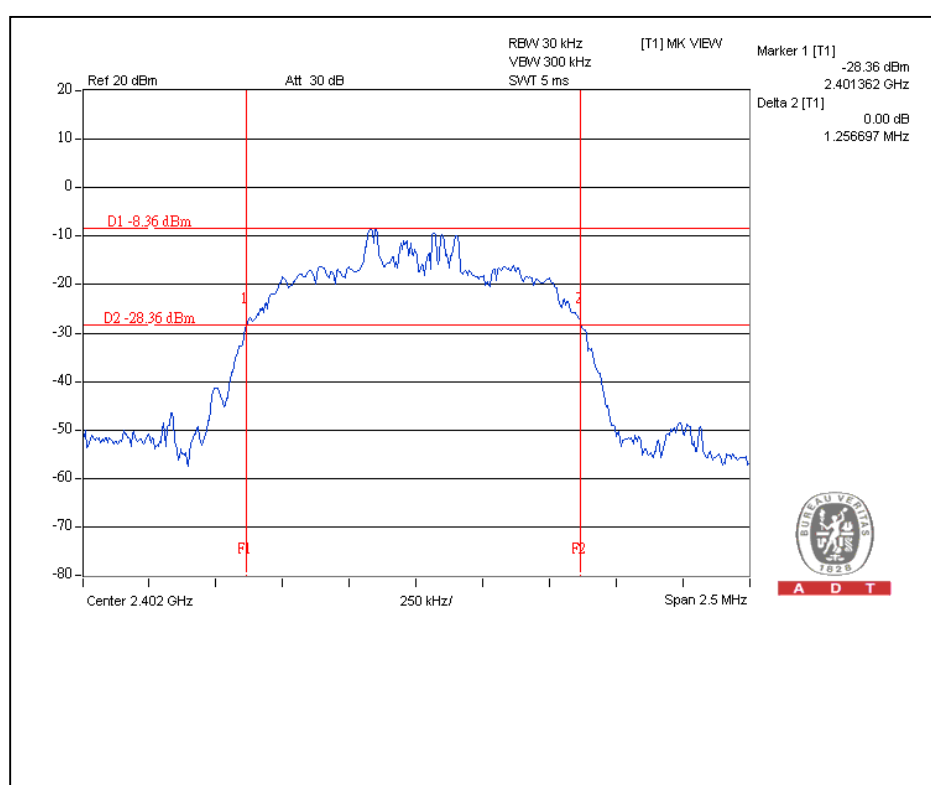



A D T

Channel 39

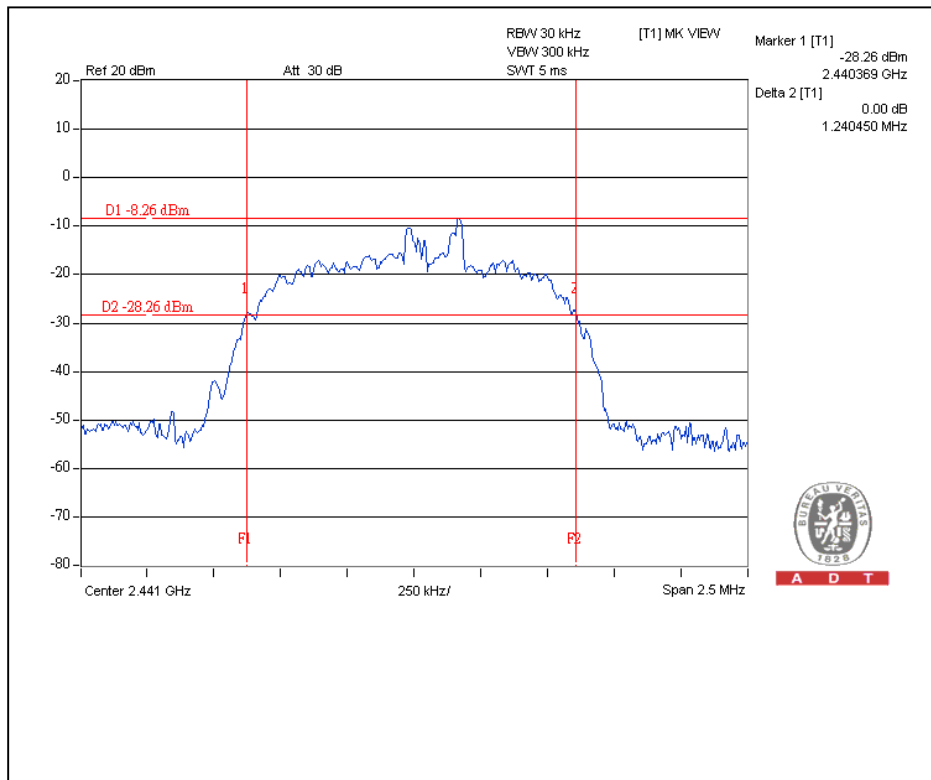

Channel 78

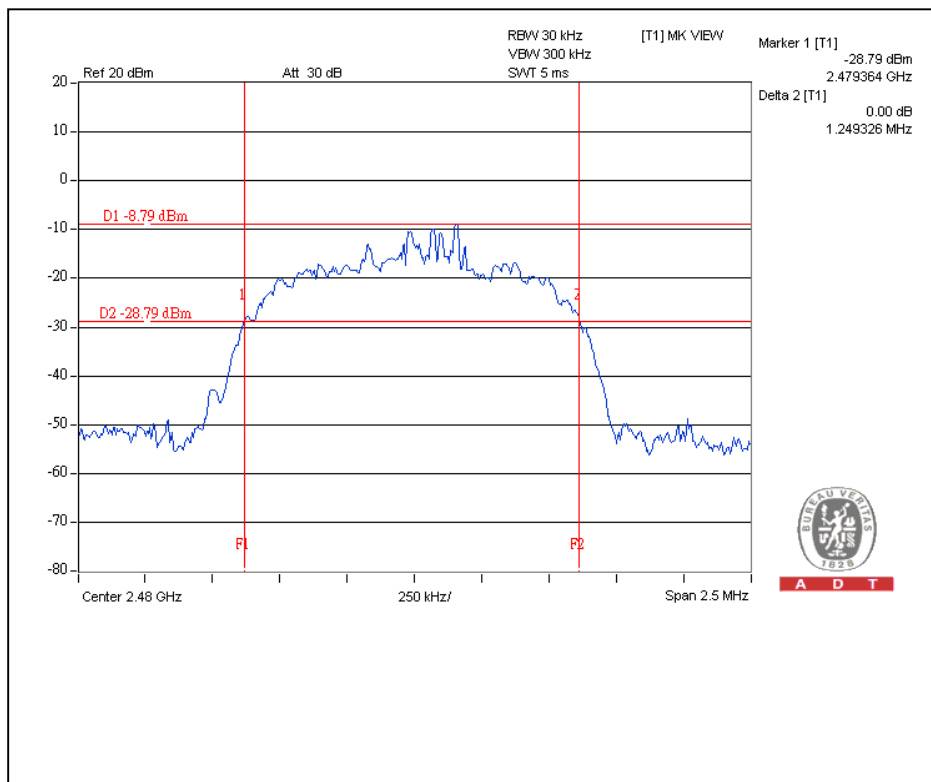

4.5 HOPPING CHANNEL SEPARATION

4.5.1 LIMIT OF HOPPING CHANNEL SEPARATION

At least 25 kHz or two-thirds of 20dB hopping channel bandwidth (whichever is greater).

4.5.2 TEST INSTRUMENTS

DESCRIPTION & MANUFACTURER	MODEL NO.	SERIAL NO.	CALIBRATED DATE	CALIBRATED UNTIL
Spectrum Analyzer	E4446A	MY48250253	Aug. 03, 2009	Aug. 02, 2010

NOTE: The calibration interval of the above test instruments is 12 months and the calibrations are traceable to NML/ROC and NIST/USA.

4.5.3 TEST PROCEDURES

1. Check the calibration of the measuring instrument using either an internal calibrator or a known signal from an external generator.
2. Turn on the EUT and connect it to measurement instrument. Then set it to any one convenient frequency within its operating range.
3. By using the MaxHold function record the separation of two adjacent channels.
4. Measure the frequency difference of these two adjacent channels by SA MARK function. And then plot the result on SA screen.
5. Repeat above procedures until all frequencies measured were complete.



A D T

4.5.4 DEVIATION FROM TEST STANDARD

No deviation

4.5.5 TEST SETUP

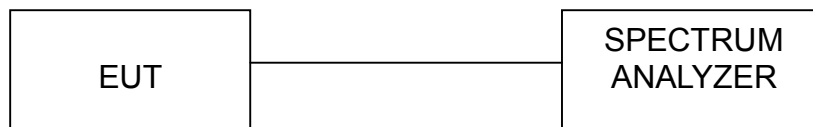



A D T

4.5.6 TEST RESULTS

For GFSK

Channel	Frequency (MHz)	Adjacent Channel Separation (MHz)	Minimum Limit (MHz)	Pass / Fail
0	2402	1.003	0.633	PASS
39	2441	1.008	0.627	PASS
78	2480	1.006	0.627	PASS

The minimum limit is two-thirds of 20dB bandwidth. Test results please refer to below pages.

Channel 0

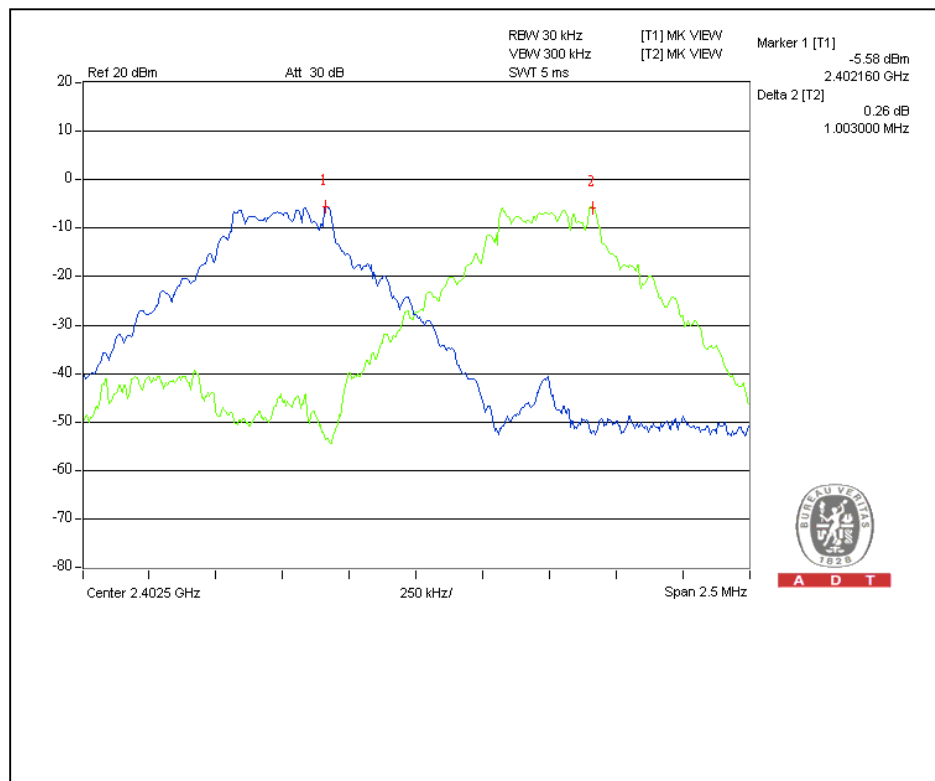



A D T

Channel 39

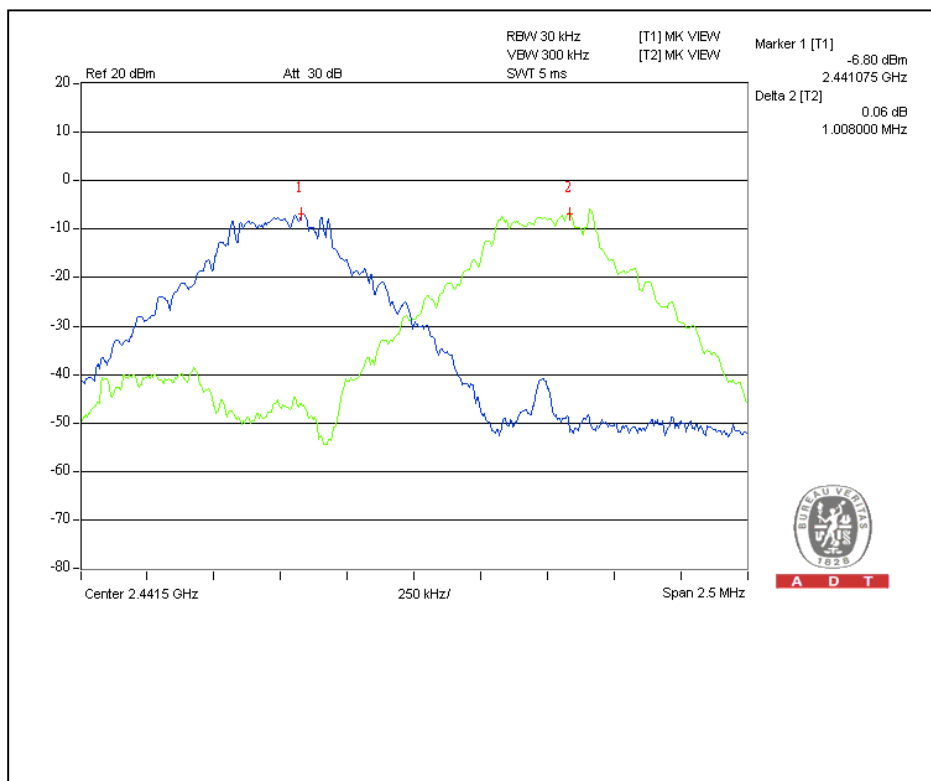

Channel 78

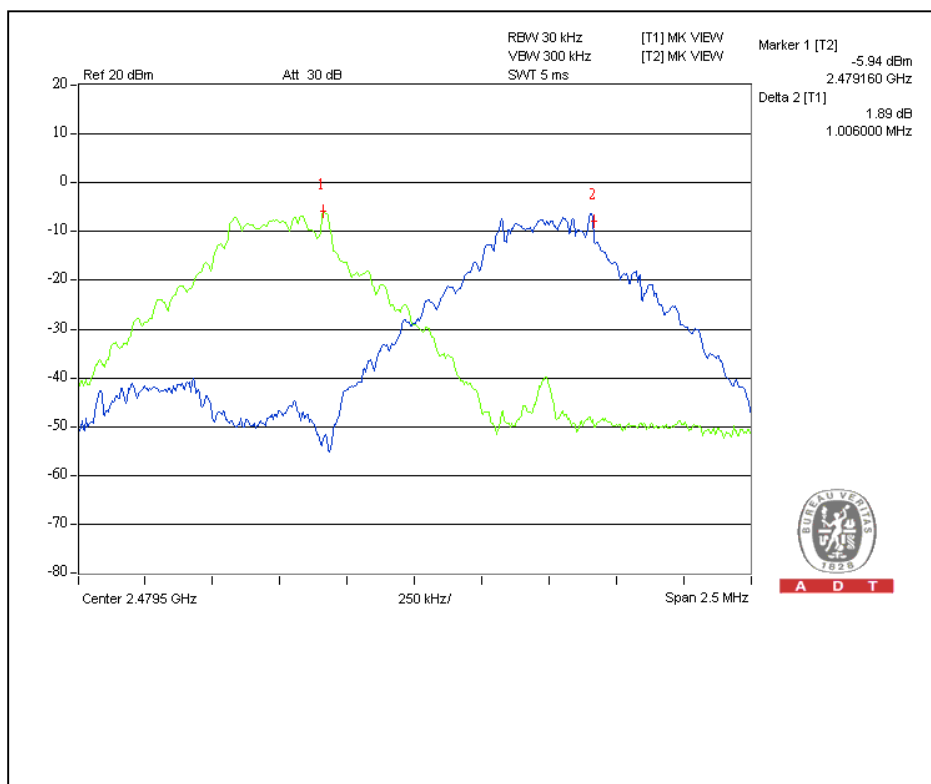



A D T

For 8DPSK

Channel	Frequency (MHz)	Adjacent Channel Separation (MHz)	Minimum Limit (MHz)	Pass / Fail
0	2402	1.006	0.840	PASS
39	2441	1.001	0.887	PASS
78	2480	1.004	0.820	PASS

The minimum limit is two-thirds of 20dB bandwidth. Test results please refer to below pages.

Channel 0

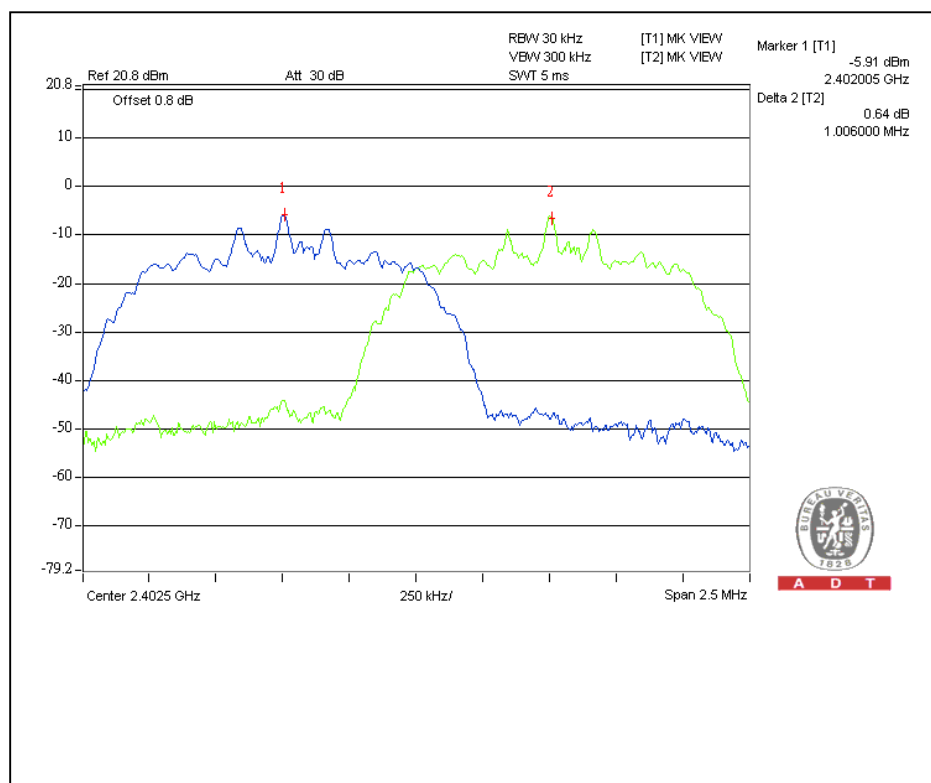



A D T

For $\pi/4$ -DQPSK

Channel	Frequency (MHz)	Adjacent Channel Separation (MHz)	Minimum Limit (MHz)	Pass / Fail
0	2402	1.003	0.833	PASS
39	2441	1.006	0.827	PASS
78	2480	1.004	0.827	PASS

The minimum limit is two-thirds of 20dB bandwidth. Test results please refer to below pages.

Channel 0

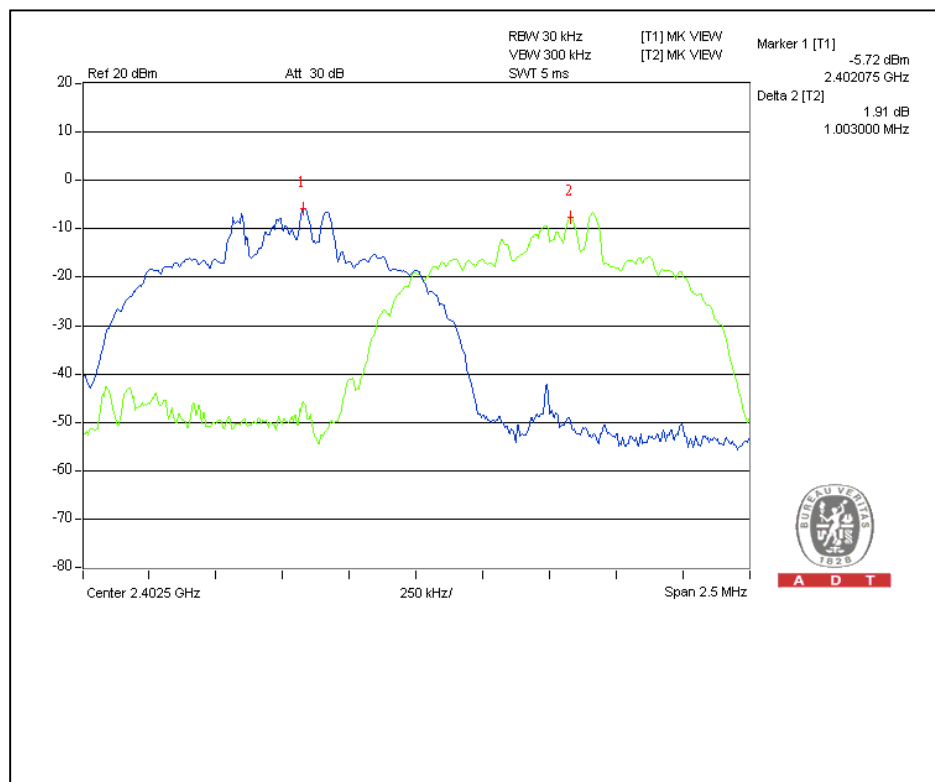



A D T

Channel 39

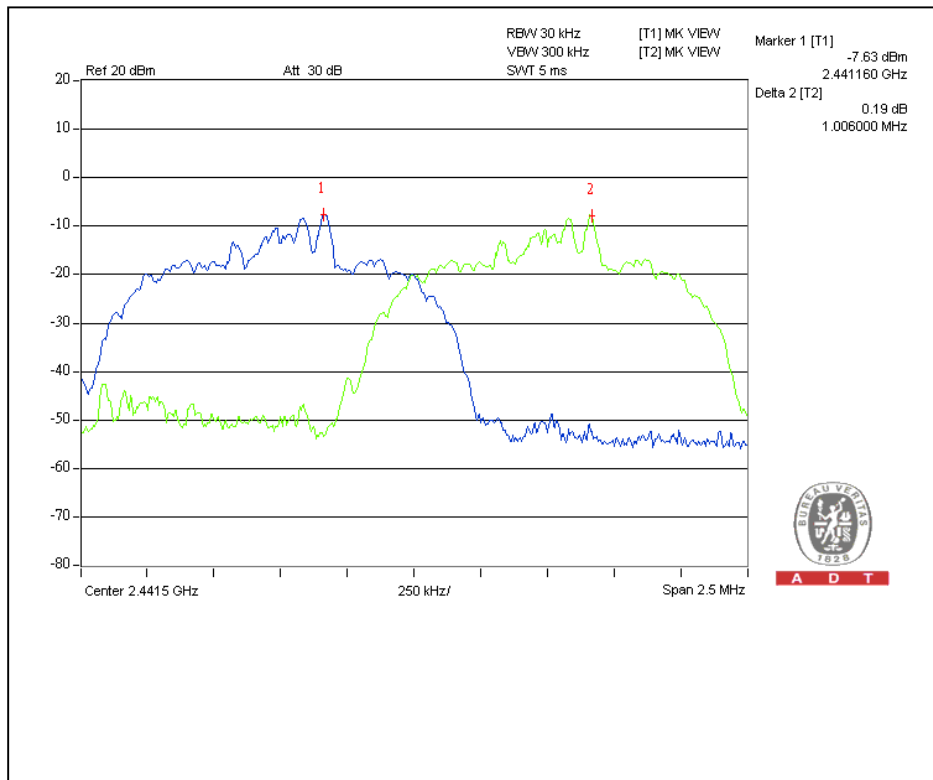

Channel 78

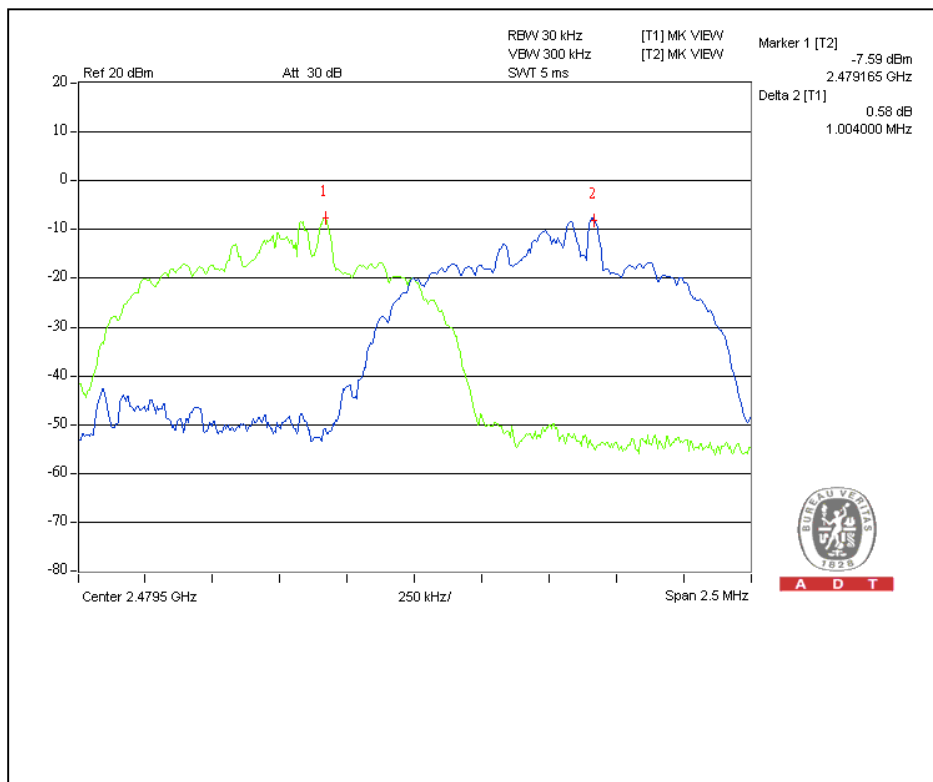

4.6 MAXIMUM PEAK OUTPUT POWER

4.6.1 LIMITS OF MAXIMUM PEAK OUTPUT POWER MEASUREMENT

The Maximum Peak Output Power Limit is 125mW.

4.6.2 INSTRUMENTS

DESCRIPTION & MANUFACTURER	MODEL NO.	SERIAL NO.	CALIBRATED DATE	CALIBRATED UNTIL
Spectrum Analyzer	E4446A	MY48250253	Aug. 03, 2009	Aug. 02, 2010

NOTE: The calibration interval of the above test instruments is 12 months and the calibrations are traceable to NML/ROC and NIST/USA.

4.6.3 TEST PROCEDURES

1. Check the calibration of the measuring instrument using either an internal calibrator or a known signal from an external generator.
2. Turn on the EUT and connect it to measurement instrument. Then set it to any one convenient frequency within its operating range. Set a reference level on the measuring instrument equal to the highest peak value.
3. The center frequency of the spectrum analyzer is set to the fundamental frequency and using 3 MHz RBW and 3 MHz VBW.
4. Measure the captured power within the band and recording the plot.
5. Repeat above procedures until all frequencies measured were complete.

4.6.4 DEVIATION FROM TEST STANDARD

No deviation

4.6.5 TEST SETUP

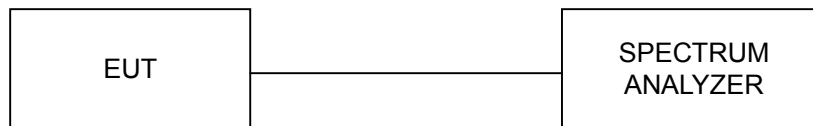

For the actual test configuration, please refer to the related Item – Photographs of the Test Configuration.

4.6.6 EUT OPERATING CONDITION

The software provided by client enabled the EUT to transmit and receive data at lowest, middle and highest channel frequencies individually.



A D T

Channel 39

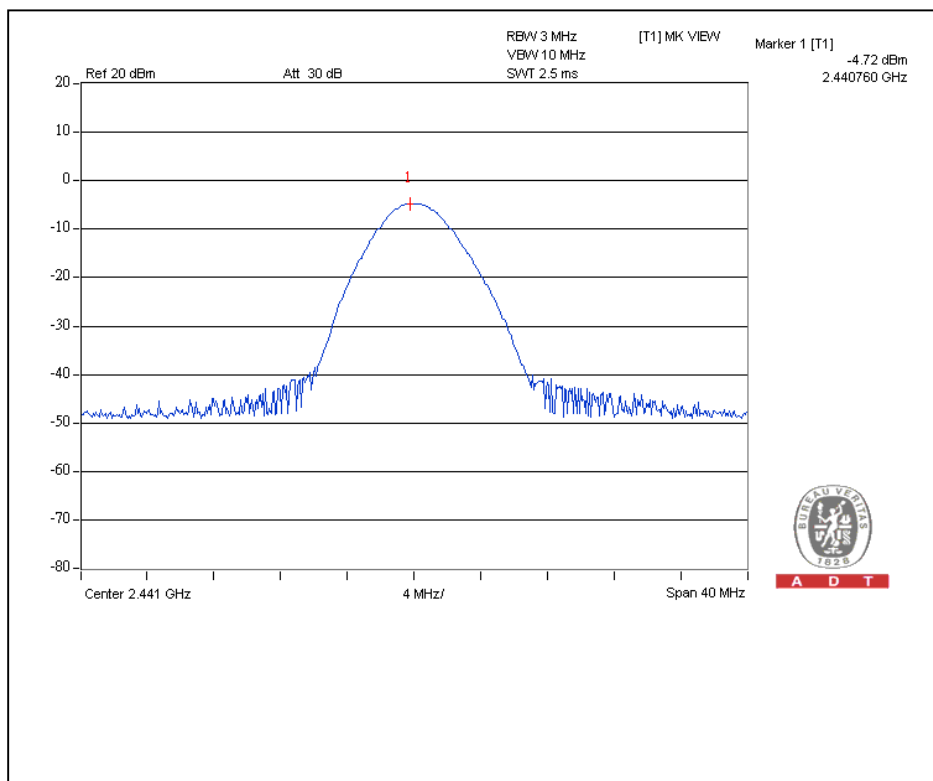

Channel 78

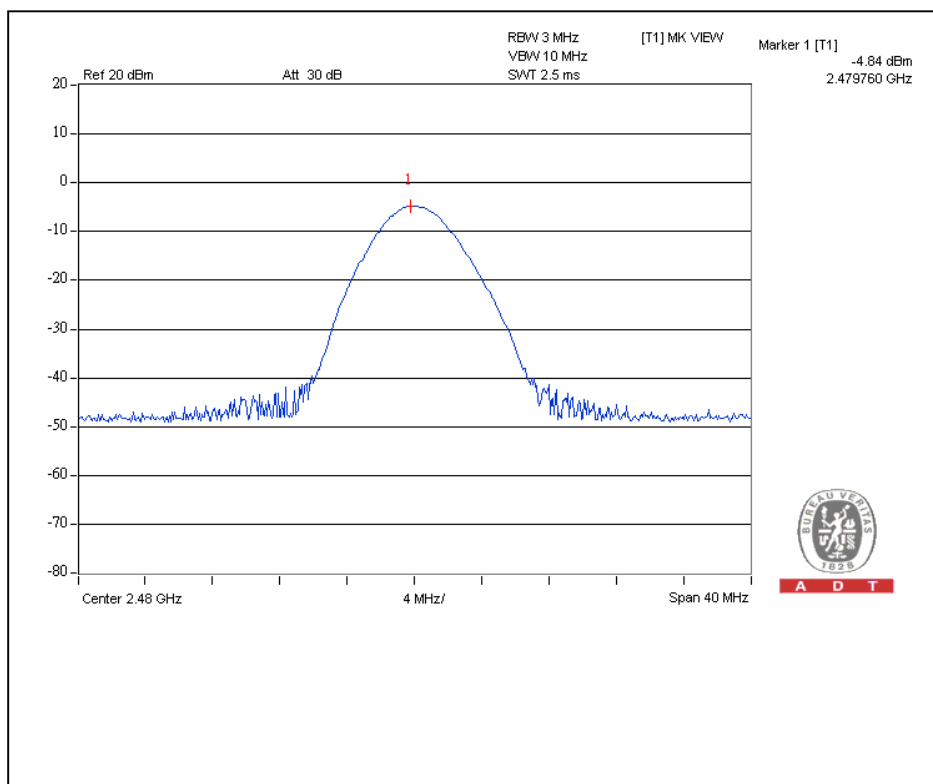



A D T

For 8DPSK

CHANNEL	CHANNEL FREQUENCY (MHz)	PEAK POWER OUTPUT (mW)	PEAK POWER OUTPUT (dBm)	PEAK POWER LIMIT (mW)	PASS/FAIL
0	2402	0.3	-4.6	125	PASS
39	2441	0.3	-5.7	125	PASS
78	2480	0.2	-6.1	125	PASS

Channel 0

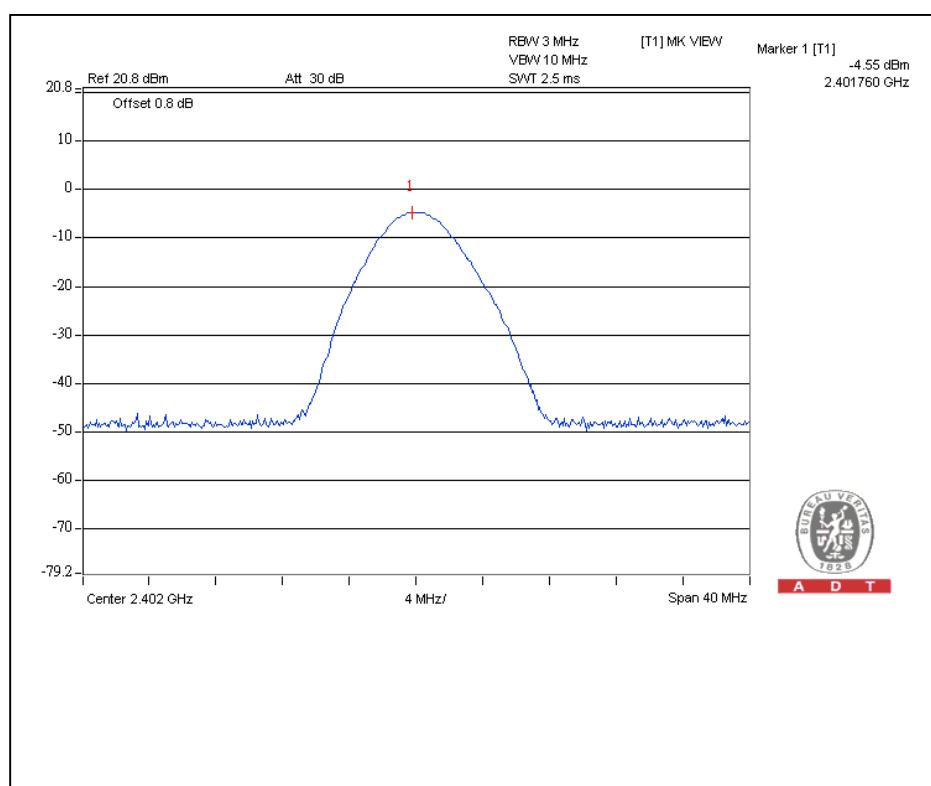



A D T

Channel 39

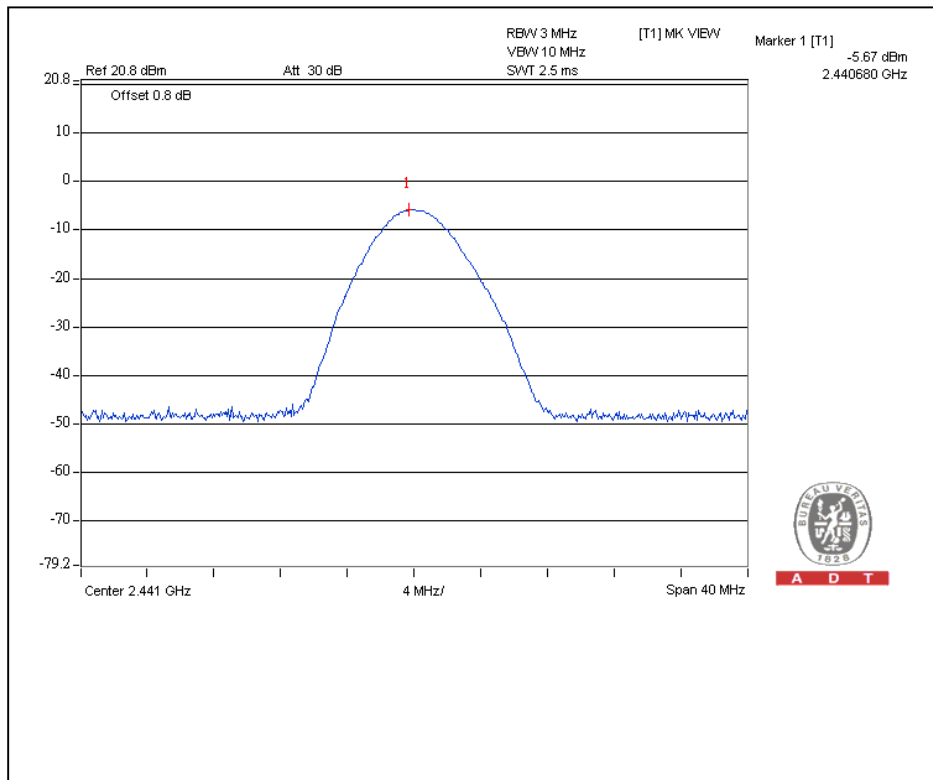

Channel 78

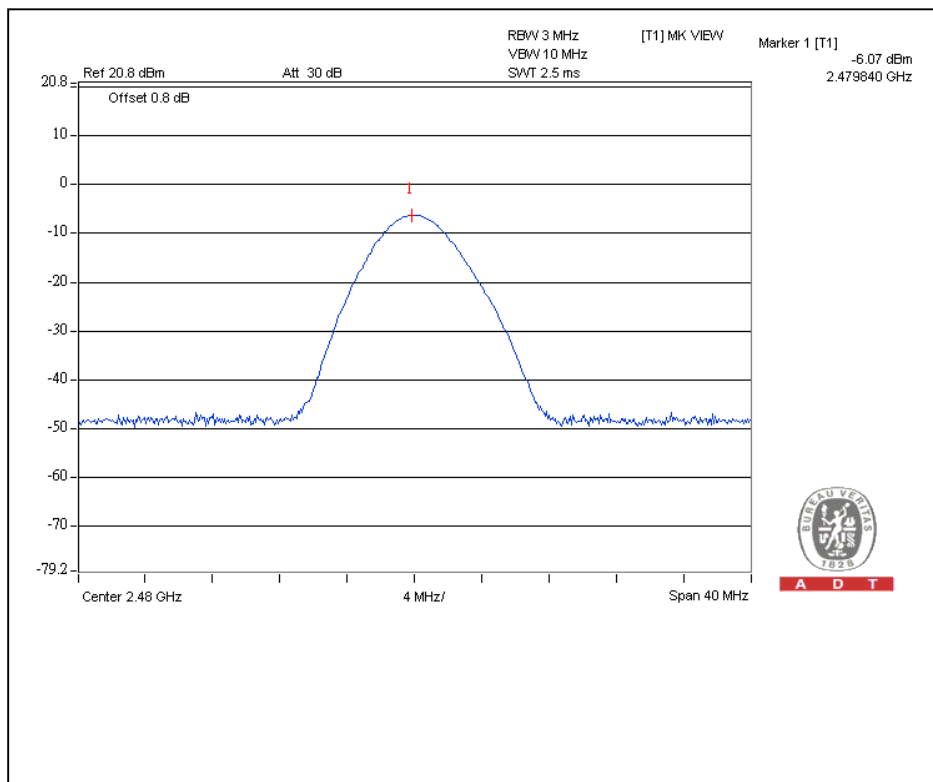



A D T

For $\pi/4$ -DQPSK

CHANNEL	CHANNEL FREQUENCY (MHz)	PEAK POWER OUTPUT (mW)	PEAK POWER OUTPUT (dBm)	PEAK POWER LIMIT (mW)	PASS/FAIL
0	2402	0.4	-4.0	125	PASS
39	2441	0.3	-5.0	125	PASS
78	2480	0.3	-5.1	125	PASS

Channel 0

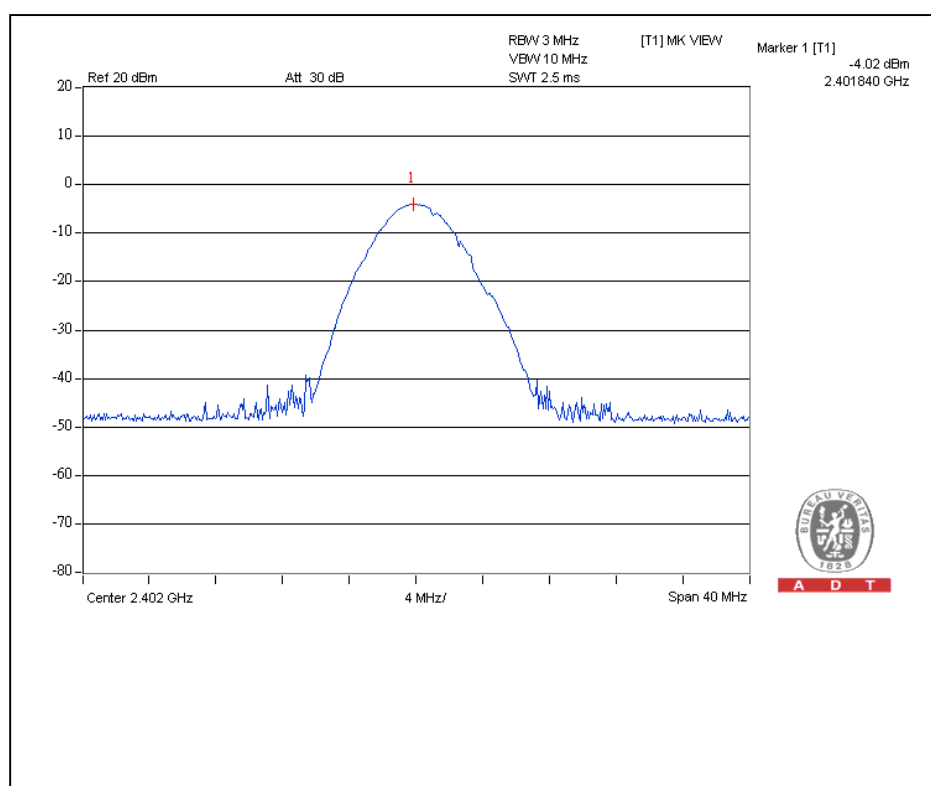



A D T

Channel 39

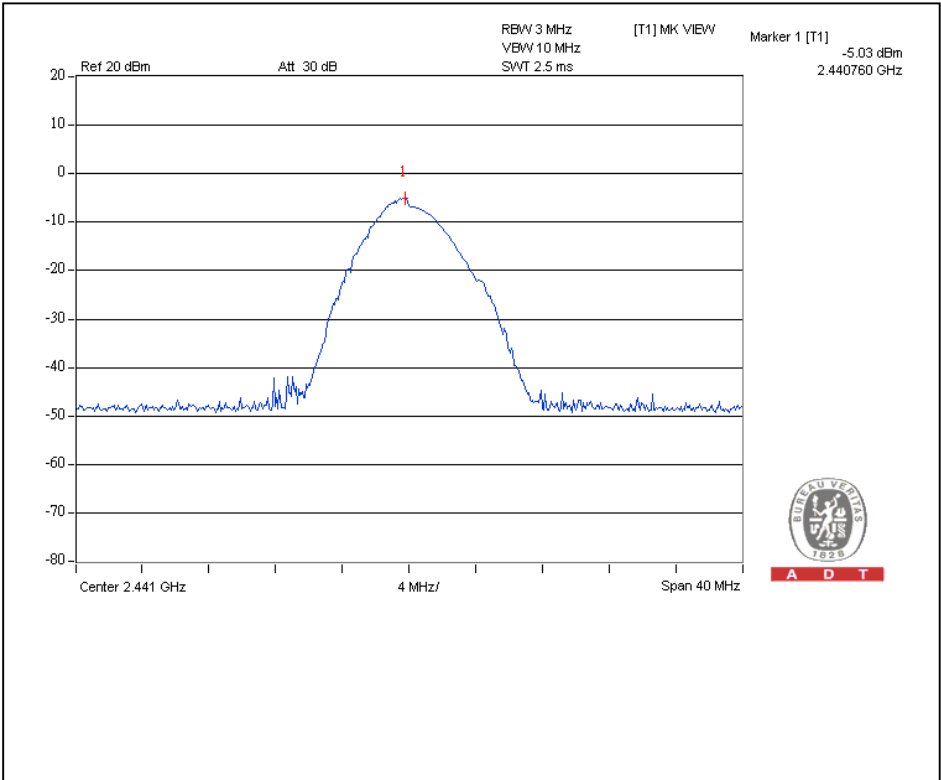

Channel 78

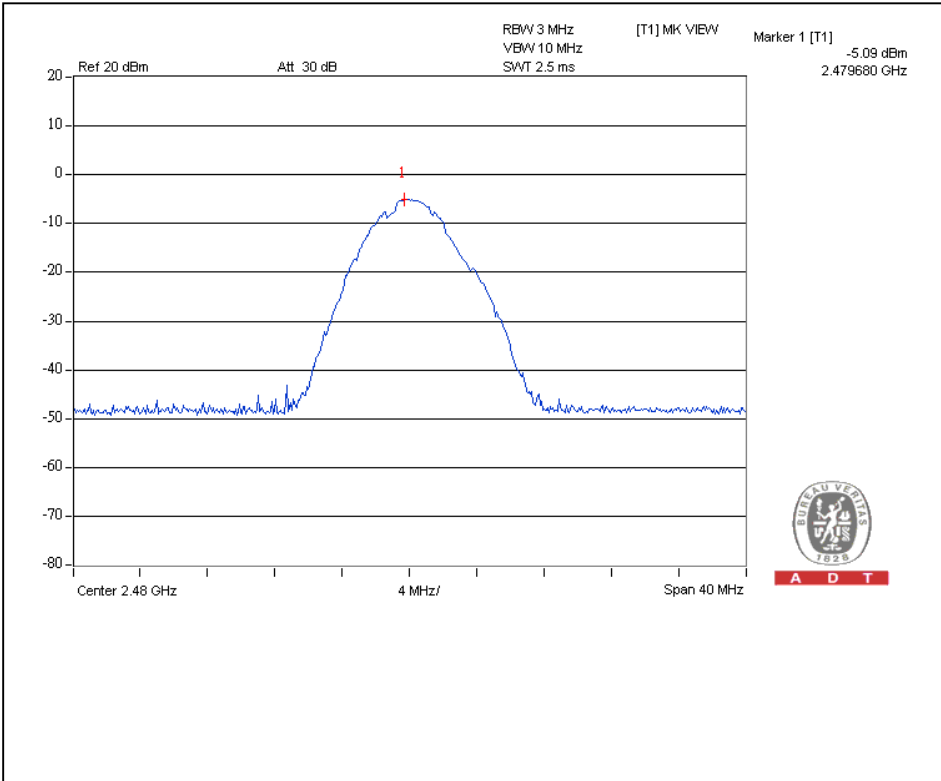

4.7 RADIATED EMISSION MEASUREMENT

4.7.1 LIMITS OF RADIATED EMISSION MEASUREMENT

Emissions radiated outside of the specified bands, shall be according to the general radiated limits in 15.209 as following:

Frequencies (MHz)	Field strength (microvolts/meter)	Measurement distance (meters)
0.009-0.490	2400/F(kHz)	300
0.490-1.705	24000/F(kHz)	30
1.705-30.0	30	30
30-88	100	3
88-216	150	3
216-960	200	3
Above 960	500	3

As shown in 15.35(b), for frequencies above 1000MHz, the field strength limits are based on average detector, however, the peak field strength of any emission shall not exceed the maximum permitted average limits, specified above by more than 20dB under any condition of modulation.



A D T

4.7.2 TEST INSTRUMENTS

DESCRIPTION & MANUFACTURER	MODEL NO.	SERIAL NO.	CALIBRATED DATE	CALIBRATED UNTIL
ROHDE & SCHWARZ Spectrum Analyzer	FSP40	100036	Dec. 18, 2009	Dec. 17, 2010
Agilent PSA Spectrum Analyzer	E4446A	MY46180622	May 12, 2010	May 11, 2011
HP Pre_Amplifier	8449B	300801923	Nov. 02, 2009	Nov. 01, 2010
ROHDE & SCHWARZ Test Receiver	ESCS30	847124/029	Aug. 28, 2009	Aug. 27, 2010
SCHWARZBECK TRILOG Broadband Antenna	VULB 9168	138	Apr. 28, 2010	Apr. 27, 2011
Schwarzbeck Horn_Antenna	BBHA9120	D124	Dec. 18, 2009	Dec. 17, 2010
Schwarzbeck Horn_Antenna	BBHA 9170	BBHA9170153	Jan. 22, 2010	Jan. 21, 2011
RF Switches	EMH-011	1001	NA	NA
RF CABLE (Chaintek)	Sucoflex 106	28077	Aug. 14, 2009	Aug. 13, 2010
RF Cable	8DFB	STCCAB-30M-1GHz	NA	NA
Software	ADT_Radiated_V7.6.15.9.2	NA	NA	NA
CT Antenna Tower & Turn Table	NA	NA	NA	NA

Note: 1. The calibration interval of the above test instruments is 12 months and the calibrations are traceable to NML/ROC and NIST/USA.

2. The horn antenna, preamplifier (model: 8449B) and Spectrum Analyzer (model: FSP40) are used only for the measurement of emission frequency above 1GHz if tested.

3. The test was performed in Open Site No. C.

4. The FCC Site Registration No. is 656396.

5. The VCCI Site Registration No. is R-1626.

6. The CANADA Site Registration No. is IC 7450G-3.

4.7.3 TEST PROCEDURES

- a. The EUT was placed on the top of a rotating table 0.8 meters above the ground at 10 meter open area test site. The table was rotated 360 degrees to determine the position of the highest radiation.
- b. The EUT was set 3 meters away from the interference-receiving antenna, which was mounted on the top of a variable-height antenna tower.
- c. The antenna is a broadband antenna, and its height is varied from one meter to four meters above the ground to determine the maximum value of the field strength. Both horizontal and vertical polarizations of the antenna are set to make the measurement.
- d. For each suspected emission, the EUT was arranged to its worst case and then the antenna was tuned to heights from 1 meter to 4 meters and the rotatable table was turned from 0 degrees to 360 degrees to find the maximum reading.
- e. The test-receiver system was set to peak and average detect function and specified bandwidth with maximum hold mode when the test frequency is above 1 GHz.

NOTE:

1. The resolution bandwidth and video bandwidth of test receiver/spectrum analyzer is 120kHz for Peak detection (PK) and Quasi-peak detection (QP) at frequency below 1GHz.
2. The resolution bandwidth is 1MHz and video bandwidth of test receiver/spectrum analyzer is 3MHz for Peak detection at frequency above 1GHz.

4.7.4 DEVIATION FROM TEST STANDARD

No deviation

4.7.5 TEST SETUP

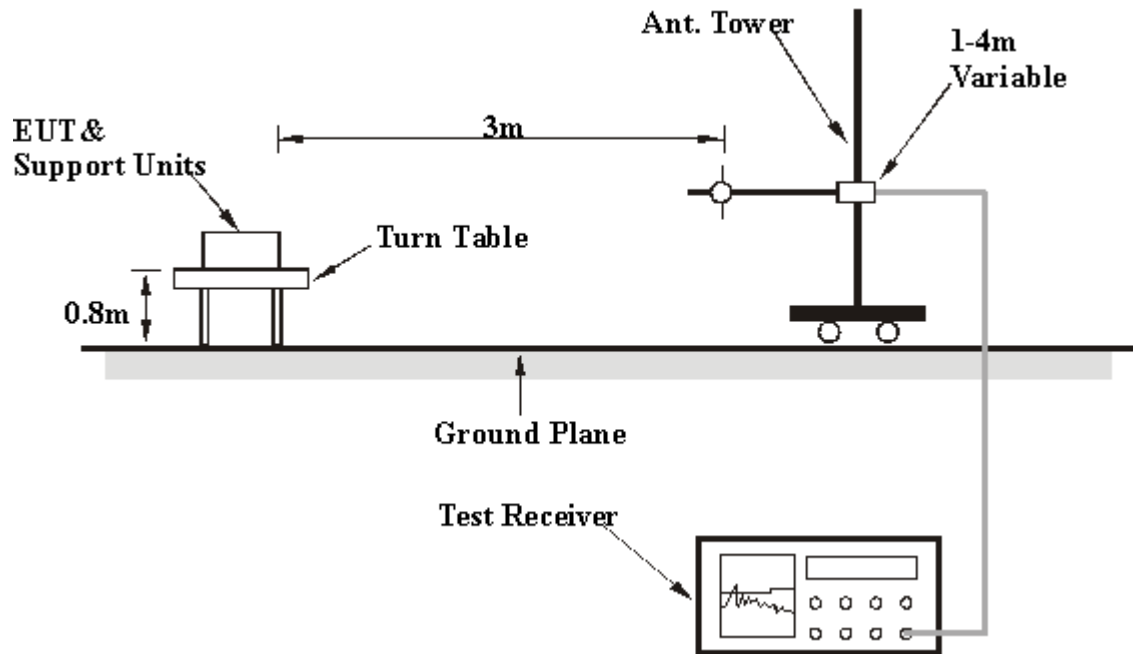

For the actual test configuration, please refer to the related item – Photographs of the Test Configuration.

4.7.6 TEST RESULTS

BELOW 1GHz WORST-CASE DATA : GFSK MODULATION

EUT TEST CONDITION		MEASUREMENT DETAIL	
CHANNEL	Channel 0	FREQUENCY RANGE	Below 1000MHz
INPUT POWER	120Vac, 60 Hz	DETECTOR FUNCTION	Quasi-Peak
ENVIRONMENTAL CONDITIONS	28deg. C, 60%RH 1015 hPa	TESTED BY	Wen Yu

ANTENNA POLARITY & TEST DISTANCE: HORIZONTAL AT 3 M								
NO.	FREQ. (MHz)	EMISSION LEVEL (dBuV/m)	LIMIT (dBuV/m)	MARGIN (dB)	ANTENNA HEIGHT (m)	TABLE ANGLE (Degree)	RAW VALUE (dBuV)	CORRECTION FACTOR (dB/m)
1	78.72	26.3 QP	40.0	-13.7	1.32 H	9	15.54	10.73
2	285.23	34.3 QP	46.0	-11.7	1.22 H	162	18.93	15.33
3	375.00	36.8 QP	46.0	-9.2	1.32 H	227	18.89	17.90
4	488.02	38.8 QP	46.0	-7.2	1.36 H	232	17.79	20.97
5	600.00	44.4 QP	46.0	-1.6	1.00 H	8	20.52	23.87
6	699.98	41.8 QP	46.0	-4.2	1.00 H	40	16.89	24.89
7	750.05	42.8 QP	46.0	-3.2	1.00 H	19	17.06	25.71
8	850.04	42.4 QP	46.0	-3.6	1.00 H	29	15.04	27.36
9	1000.00	40.5 QP	54.0	-13.5	1.46 H	328	11.49	29.04

ANTENNA POLARITY & TEST DISTANCE: VERTICAL AT 3 M								
NO.	FREQ. (MHz)	EMISSION LEVEL (dBuV/m)	LIMIT (dBuV/m)	MARGIN (dB)	ANTENNA HEIGHT (m)	TABLE ANGLE (Degree)	RAW VALUE (dBuV)	CORRECTION FACTOR (dB/m)
1	80.00	31.5 QP	40.0	-8.5	1.00 V	209	21.04	10.42
2	244.00	34.2 QP	46.0	-11.8	1.00 V	219	20.76	13.48
3	375.00	36.9 QP	46.0	-9.1	1.00 V	28	19.03	17.90
4	426.99	41.0 QP	46.0	-5.0	1.00 V	0	21.70	19.27
5	600.00	39.9 QP	46.0	-6.1	1.00 V	70	16.06	23.87
6	675.00	41.5 QP	46.0	-4.5	1.24 V	175	16.87	24.63
7	750.03	42.0 QP	46.0	-4.0	1.37 V	307	16.32	25.71
8	853.99	43.0 QP	46.0	-3.0	1.42 V	68	15.61	27.43
9	975.98	41.8 QP	54.0	-12.2	1.37 V	208	12.94	28.82
10	1000.00	40.8 QP	54.0	-13.2	1.42 V	14	11.74	29.04
11	1000.00	41.3 QP	54.0	-12.7	1.42 V	73	12.28	29.04

- REMARKS:**
1. Emission level (dBuV/m) = Raw Value (dBuV) + Correction Factor (dB/m).
 2. Correction Factor (dB/m) = Antenna Factor (dB/m) + Cable Factor (dB).
 3. The other emission levels were very low against the limit.
 4. Margin value = Emission level – Limit value.



A D T

GFSK MODULATION

EUT TEST CONDITION		MEASUREMENT DETAIL	
CHANNEL	Channel 0	FREQUENCY RANGE	1 ~ 25GHz
INPUT POWER	120Vac, 60 Hz	DETECTOR FUNCTION	Peak (PK) Average (AV)
ENVIRONMENTAL CONDITIONS	28deg. C, 60%RH 1015 hPa	TESTED BY	Wen Yu

ANTENNA POLARITY & TEST DISTANCE: HORIZONTAL AT 3 M								
NO.	FREQ. (MHz)	EMISSION LEVEL (dBuV/m)	LIMIT (dBuV/m)	MARGIN (dB)	ANTENNA HEIGHT (m)	TABLE ANGLE (Degree)	RAW VALUE (dBuV)	CORRECTION FACTOR (dB/m)
1	2390.00	53.5 PK	74.0	-20.5	1.36 H	168	23.40	30.10
2	2390.00	23.4 AV	54.0	-30.6	1.36 H	168	-6.70	30.10
3	*2402.00	100.8 PK			1.36 H	168	70.70	30.10
4	*2402.00	70.7 AV			1.36 H	168	40.60	30.10
5	4804.00	44.2 PK	74.0	-29.8	1.00 H	119	8.80	35.40
6	4804.00	14.1 AV	54.0	-39.9	1.00 H	119	-21.30	35.40
ANTENNA POLARITY & TEST DISTANCE: VERTICAL AT 3 M								
NO.	FREQ. (MHz)	EMISSION LEVEL (dBuV/m)	LIMIT (dBuV/m)	MARGIN (dB)	ANTENNA HEIGHT (m)	TABLE ANGLE (Degree)	RAW VALUE (dBuV)	CORRECTION FACTOR (dB/m)
1	2390.00	52.7 PK	74.0	-21.3	1.09 V	155	22.60	30.10
2	2390.00	22.6 AV	54.0	-31.4	1.09 V	155	-7.50	30.10
3	*2402.00	96.5 PK			1.09 V	155	66.40	30.10
4	*2402.00	66.4 AV			1.09 V	155	36.30	30.10
5	4804.00	45.4 PK	74.0	-28.6	1.53 V	218	10.00	35.40
6	4804.00	15.3 AV	54.0	-38.7	1.53 V	218	-20.10	35.40

- REMARKS:**
1. Emission level (dBuV/m) = Raw Value (dBuV) + Correction Factor (dB/m).
 2. Correction Factor (dB/m) = Antenna Factor (dB/m) + Cable Factor (dB).
 3. The other emission levels were very low against the limit.
 4. Margin value = Emission level – Limit value.
 5. “ * “: Fundamental frequency.
 6. The DH5 packet was the worse case duty cycle for a transmit dwell time on a channel, based upon bluetooth theory the transmitter is on 0.625 * 5 per 296.25 ms per channel. Therefore, the duty cycle correlation factor be equal to: $20\log(3.125 / 100) = -30.1$ dB.
 7. Average value = peak reading + $20\log(\text{duty cycle})$.



A D T

EUT TEST CONDITION		MEASUREMENT DETAIL	
CHANNEL	Channel 39	FREQUENCY RANGE	1 ~ 25GHz
INPUT POWER	120Vac, 60 Hz	DETECTOR FUNCTION	Peak (PK) Average (AV)
ENVIRONMENTAL CONDITIONS	28deg. C, 60%RH 1015 hPa	TESTED BY	Wen Yu

ANTENNA POLARITY & TEST DISTANCE: HORIZONTAL AT 3 M								
NO.	FREQ. (MHz)	EMISSION LEVEL (dBuV/m)	LIMIT (dBuV/m)	MARGIN (dB)	ANTENNA HEIGHT (m)	TABLE ANGLE (Degree)	RAW VALUE (dBuV)	CORRECTION FACTOR (dB/m)
1	*2441.00	102.4 PK			1.33 H	172	72.10	30.30
2	*2441.00	72.3 AV			1.33 H	172	42.00	30.30
3	4882.00	46.3 PK	74.0	-27.7	1.07 H	240	10.80	35.50
4	4882.00	16.2 AV	54.0	-37.8	1.07 H	240	-19.30	35.50
5	7323.00	48.2 PK	74.0	-25.8	1.58 H	66	6.20	42.00
6	7323.00	18.1 AV	54.0	-35.9	1.58 H	66	-23.90	42.00
ANTENNA POLARITY & TEST DISTANCE: VERTICAL AT 3 M								
NO.	FREQ. (MHz)	EMISSION LEVEL (dBuV/m)	LIMIT (dBuV/m)	MARGIN (dB)	ANTENNA HEIGHT (m)	TABLE ANGLE (Degree)	RAW VALUE (dBuV)	CORRECTION FACTOR (dB/m)
1	*2441.00	98.1 PK			1.14 V	255	67.80	30.30
2	*2441.00	68.0 AV			1.14 V	255	37.70	30.30
3	4882.00	45.4 PK	74.0	-28.6	1.51 V	224	9.90	35.50
4	4882.00	15.3 AV	54.0	-38.7	1.51 V	224	-20.20	35.50
5	7323.00	48.9 PK	74.0	-25.1	1.32 V	2	6.90	42.00
6	7323.00	18.8 AV	54.0	-35.2	1.32 V	2	-23.20	42.00

- REMARKS:**
1. Emission level (dBuV/m) = Raw Value (dBuV) + Correction Factor (dB/m).
 2. Correction Factor (dB/m) = Antenna Factor (dB/m) + Cable Factor (dB).
 3. The other emission levels were very low against the limit.
 4. Margin value = Emission level – Limit value.
 5. “ * “: Fundamental frequency.
 6. The DH5 packet was the worse case duty cycle for a transmit dwell time on a channel, based upon bluetooth theory the transmitter is on 0.625 * 5 per 296.25 ms per channel. Therefore, the duty cycle correlation factor be equal to: $20\log(3.125 / 100) = -30.1$ dB.
 7. Average value = peak reading + $20\log(\text{duty cycle})$.



A D T

EUT TEST CONDITION		MEASUREMENT DETAIL	
CHANNEL	Channel 78	FREQUENCY RANGE	1 ~ 25GHz
INPUT POWER	120Vac, 60 Hz	DETECTOR FUNCTION	Peak (PK) Average (AV)
ENVIRONMENTAL CONDITIONS	28deg. C, 60%RH 1015 hPa	TESTED BY	Wen Yu

ANTENNA POLARITY & TEST DISTANCE: HORIZONTAL AT 3 M								
NO.	FREQ. (MHz)	EMISSION LEVEL (dBuV/m)	LIMIT (dBuV/m)	MARGIN (dB)	ANTENNA HEIGHT (m)	TABLE ANGLE (Degree)	RAW VALUE (dBuV)	CORRECTION FACTOR (dB/m)
1	*2480.00	102.1 PK			1.26 H	174	71.70	30.40
2	*2480.00	72.0 AV			1.26 H	174	41.60	30.40
3	2483.53	57.0 PK	74.0	-17.0	1.26 H	173	26.60	30.40
4	2483.53	26.9 AV	54.0	-27.1	1.26 H	173	-3.50	30.40
5	4960.00	46.7 PK	74.0	-27.3	1.02 H	241	11.00	35.70
6	4960.00	16.6 AV	54.0	-37.4	1.02 H	241	-19.10	35.70
7	7440.00	49.0 PK	74.0	-25.0	1.46 H	78	6.80	42.20
8	7440.00	18.9 AV	54.0	-35.1	1.46 H	78	-23.30	42.20
ANTENNA POLARITY & TEST DISTANCE: VERTICAL AT 3 M								
NO.	FREQ. (MHz)	EMISSION LEVEL (dBuV/m)	LIMIT (dBuV/m)	MARGIN (dB)	ANTENNA HEIGHT (m)	TABLE ANGLE (Degree)	RAW VALUE (dBuV)	CORRECTION FACTOR (dB/m)
1	*2480.00	97.6 PK			1.17 V	263	67.20	30.40
2	*2480.00	67.5 AV			1.17 V	263	37.10	30.40
3	2483.85	54.7 PK	74.0	-19.3	1.16 V	263	24.30	30.40
4	2483.85	24.6 AV	54.0	-29.4	1.16 V	263	-5.80	30.40
5	4960.00	46.2 PK	74.0	-27.8	1.32 V	172	10.50	35.70
6	4960.00	16.1 AV	54.0	-37.9	1.32 V	172	-19.60	35.70
7	7440.00	49.2 PK	74.0	-24.8	1.47 V	348	7.00	42.20
8	7440.00	19.1 AV	54.0	-34.9	1.47 V	348	-23.10	42.20

- REMARKS:**
1. Emission level (dBuV/m) = Raw Value (dBuV) + Correction Factor (dB/m).
 2. Correction Factor (dB/m) = Antenna Factor (dB/m) + Cable Factor (dB).
 3. The other emission levels were very low against the limit.
 4. Margin value = Emission level – Limit value.
 5. “ * “: Fundamental frequency.
 6. The DH5 packet was the worse case duty cycle for a transmit dwell time on a channel, based upon bluetooth theory the transmitter is on 0.625 * 5 per 296.25 ms per channel. Therefore, the duty cycle correlation factor be equal to: $20\log(3.125 / 100) = -30.1$ dB.
 7. Average value = peak reading + $20\log(\text{duty cycle})$.



8DPSK MODULATION

EUT TEST CONDITION		MEASUREMENT DETAIL	
CHANNEL	Channel 0	FREQUENCY RANGE	1 ~ 25GHz
INPUT POWER	120Vac, 60 Hz	DETECTOR FUNCTION	Peak (PK) Average (AV)
ENVIRONMENTAL CONDITIONS	28deg. C, 60%RH 1015 hPa	TESTED BY	Wen Yu

ANTENNA POLARITY & TEST DISTANCE: HORIZONTAL AT 3 M

NO.	FREQ. (MHz)	EMISSION LEVEL (dBuV/m)	LIMIT (dBuV/m)	MARGIN (dB)	ANTENNA HEIGHT (m)	TABLE ANGLE (Degree)	RAW VALUE (dBuV)	CORRECTION FACTOR (dB/m)
1	2389.39	53.9 PK	74.0	-20.1	1.38 H	168	23.80	30.10
2	2389.39	23.8 AV	54.0	-30.2	1.38 H	168	-6.30	30.10
3	*2402.00	99.2 PK			1.38 H	168	69.10	30.10
4	*2402.00	69.1 AV			1.38 H	168	39.00	30.10
5	4804.00	43.5 PK	74.0	-30.5	1.49 H	195	8.10	35.40
6	4804.00	13.4 AV	54.0	-40.6	1.49 H	195	-22.00	35.40

ANTENNA POLARITY & TEST DISTANCE: VERTICAL AT 3 M

NO.	FREQ. (MHz)	EMISSION LEVEL (dBuV/m)	LIMIT (dBuV/m)	MARGIN (dB)	ANTENNA HEIGHT (m)	TABLE ANGLE (Degree)	RAW VALUE (dBuV)	CORRECTION FACTOR (dB/m)
1	2384.08	53.3 PK	74.0	-20.7	1.42 V	256	23.30	30.00
2	2384.08	23.2 AV	54.0	-30.8	1.42 V	256	-6.80	30.00
3	*2402.00	93.5 PK			1.42 V	256	63.40	30.10
4	*2402.00	63.4 AV			1.42 V	256	33.30	30.10
5	4804.00	43.6 PK	74.0	-30.4	1.53 V	216	8.20	35.40
6	4804.00	13.5 AV	54.0	-40.5	1.53 V	216	-21.90	35.40

- REMARKS:**
- Emission level (dBuV/m) = Raw Value (dBuV) + Correction Factor (dB/m).
 - Correction Factor (dB/m) = Antenna Factor (dB/m) + Cable Factor (dB).
 - The other emission levels were very low against the limit.
 - Margin value = Emission level – Limit value.
 - * * *: Fundamental frequency.
 - The DH5 packet was the worse case duty cycle for a transmit dwell time on a channel, based upon bluetooth theory the transmitter is on 0.625 * 5 per 296.25 ms per channel. Therefore, the duty cycle correlation factor be equal to: $20\log(3.125 / 100) = -30.1 \text{ dB}$.
 - Average value = peak reading + $20\log(\text{duty cycle})$.



A D T

EUT TEST CONDITION		MEASUREMENT DETAIL	
CHANNEL	Channel 39	FREQUENCY RANGE	1 ~ 25GHz
INPUT POWER	120Vac, 60 Hz	DETECTOR FUNCTION	Peak (PK) Average (AV)
ENVIRONMENTAL CONDITIONS	28deg. C, 60%RH 1015 hPa	TESTED BY	Wen Yu

ANTENNA POLARITY & TEST DISTANCE: HORIZONTAL AT 3 M								
NO.	FREQ. (MHz)	EMISSION LEVEL (dBuV/m)	LIMIT (dBuV/m)	MARGIN (dB)	ANTENNA HEIGHT (m)	TABLE ANGLE (Degree)	RAW VALUE (dBuV)	CORRECTION FACTOR (dB/m)
1	*2441.00	100.2 PK			1.36 H	162	69.90	30.30
2	*2441.00	70.1 AV			1.36 H	162	39.80	30.30
3	4882.00	43.6 PK	74.0	-30.4	1.45 H	201	8.10	35.50
4	4882.00	13.5 AV	54.0	-40.5	1.45 H	201	-22.00	35.50
5	7332.00	49.5 PK	74.0	-24.5	1.51 H	57	7.50	42.00
6	7332.00	19.4 AV	54.0	-34.6	1.51 H	57	-22.60	42.00
ANTENNA POLARITY & TEST DISTANCE: VERTICAL AT 3 M								
NO.	FREQ. (MHz)	EMISSION LEVEL (dBuV/m)	LIMIT (dBuV/m)	MARGIN (dB)	ANTENNA HEIGHT (m)	TABLE ANGLE (Degree)	RAW VALUE (dBuV)	CORRECTION FACTOR (dB/m)
1	*2441.00	94.9 PK			1.38 V	270	64.60	30.30
2	*2441.00	64.8 AV			1.38 V	270	34.50	30.30
3	4884.00	44.0 PK	74.0	-30.0	1.57 V	203	8.50	35.50
4	4884.00	13.9 AV	54.0	-40.1	1.57 V	203	-21.60	35.50
5	7332.00	48.7 PK	74.0	-25.3	1.36 V	355	6.70	42.00
6	7332.00	18.6 AV	54.0	-35.4	1.36 V	355	-23.40	42.00

- REMARKS:**
1. Emission level (dBuV/m) = Raw Value (dBuV) + Correction Factor (dB/m).
 2. Correction Factor (dB/m) = Antenna Factor (dB/m) + Cable Factor (dB).
 3. The other emission levels were very low against the limit.
 4. Margin value = Emission level – Limit value.
 5. “ * “: Fundamental frequency.
 6. The DH5 packet was the worse case duty cycle for a transmit dwell time on a channel, based upon bluetooth theory the transmitter is on 0.625 * 5 per 296.25 ms per channel. Therefore, the duty cycle correlation factor be equal to: $20\log(3.125 / 100) = -30.1$ dB.
 7. Average value = peak reading + $20\log(\text{duty cycle})$.



A D T

EUT TEST CONDITION		MEASUREMENT DETAIL	
CHANNEL	Channel 78	FREQUENCY RANGE	1 ~ 25GHz
INPUT POWER	120Vac, 60 Hz	DETECTOR FUNCTION	Peak (PK) Average (AV)
ENVIRONMENTAL CONDITIONS	28deg. C, 60%RH 1015 hPa	TESTED BY	Wen Yu

ANTENNA POLARITY & TEST DISTANCE: HORIZONTAL AT 3 M								
NO.	FREQ. (MHz)	EMISSION LEVEL (dBuV/m)	LIMIT (dBuV/m)	MARGIN (dB)	ANTENNA HEIGHT (m)	TABLE ANGLE (Degree)	RAW VALUE (dBuV)	CORRECTION FACTOR (dB/m)
1	*2480.00	101.5 PK			1.28 H	354	71.10	30.40
2	*2480.00	71.4 AV			1.28 H	354	41.00	30.40
3	2485.69	55.0 PK	74.0	-19.0	1.28 H	354	24.60	30.40
4	2485.69	24.9 AV	54.0	-29.1	1.28 H	354	-5.50	30.40
5	4960.00	44.5 PK	74.0	-29.5	1.44 H	103	8.80	35.70
6	4960.00	14.4 AV	54.0	-39.6	1.44 H	103	-21.30	35.70
7	7440.00	49.9 PK	74.0	-24.1	1.55 H	62	7.70	42.20
8	7440.00	19.8 AV	54.0	-34.2	1.55 H	62	-22.40	42.20
ANTENNA POLARITY & TEST DISTANCE: VERTICAL AT 3 M								
NO.	FREQ. (MHz)	EMISSION LEVEL (dBuV/m)	LIMIT (dBuV/m)	MARGIN (dB)	ANTENNA HEIGHT (m)	TABLE ANGLE (Degree)	RAW VALUE (dBuV)	CORRECTION FACTOR (dB/m)
1	*2480.00	98.8 PK			1.38 V	269	68.40	30.40
2	*2480.00	68.7 AV			1.38 V	269	38.30	30.40
3	2484.32	55.0 PK	74.0	-19.0	1.38 V	269	24.60	30.40
4	2484.32	24.9 AV	54.0	-29.1	1.38 V	269	-5.50	30.40
5	4960.00	44.1 PK	74.0	-29.9	1.55 V	214	8.40	35.70
6	4960.00	14.0 AV	54.0	-40.0	1.55 V	214	-21.70	35.70
7	7440.00	49.1 PK	74.0	-24.9	1.32 V	351	6.90	42.20
8	7440.00	19.0 AV	54.0	-35.0	1.32 V	351	-23.20	42.20

- REMARKS:**
1. Emission level (dBuV/m) = Raw Value (dBuV) + Correction Factor (dB/m).
 2. Correction Factor (dB/m) = Antenna Factor (dB/m) + Cable Factor (dB).
 3. The other emission levels were very low against the limit.
 4. Margin value = Emission level – Limit value.
 5. “ * “: Fundamental frequency.
 6. The DH5 packet was the worse case duty cycle for a transmit dwell time on a channel, based upon bluetooth theory the transmitter is on 0.625 * 5 per 296.25 ms per channel. Therefore, the duty cycle correlation factor be equal to: $20\log(3.125 / 100) = -30.1$ dB.
 7. Average value = peak reading + $20\log(\text{duty cycle})$.

4.8 CONDUCTED OUT-BAND EMISSION MEASUREMENT

4.8.1 LIMITS OF CONDUCTED OUT-BAND EMISSION MEASUREMENT

Below -20dB of the highest emission level of operating band (in 100kHz RBW).

4.8.2 TEST INSTRUMENTS

DESCRIPTION & MANUFACTURER	MODEL NO.	SERIAL NO.	CALIBRATED DATE	CALIBRATED UNTIL
Spectrum Analyzer	E4446A	MY48250253	Aug. 03, 2009	Aug. 02, 2010

NOTE: The calibration interval of the above test instruments is 12 months and the calibrations are traceable to NML/ROC and NIST/USA.

4.8.3 TEST PROCEDURE

The transmitter output was connected to the spectrum analyzer via a low loss cable. Set RBW of spectrum analyzer to 100 kHz and VBW of spectrum analyzer to 300 kHz with suitable frequency span including 100 MHz bandwidth from band edge. The band edges were measured and recorded.

4.8.4 DEVIATION FROM TEST STANDARD

No deviation

4.8.5 EUT OPERATING CONDITION

The software provided by client enabled the EUT to transmit and receive data at lowest, middle and highest channel frequencies individually.

4.8.6 TEST RESULTS

Emissions radiated outside of the specified frequency bands, please refer following pages for met the requirement of the general radiated emission limits in § 15.209.

For GFSK Modulation Type:

CH0

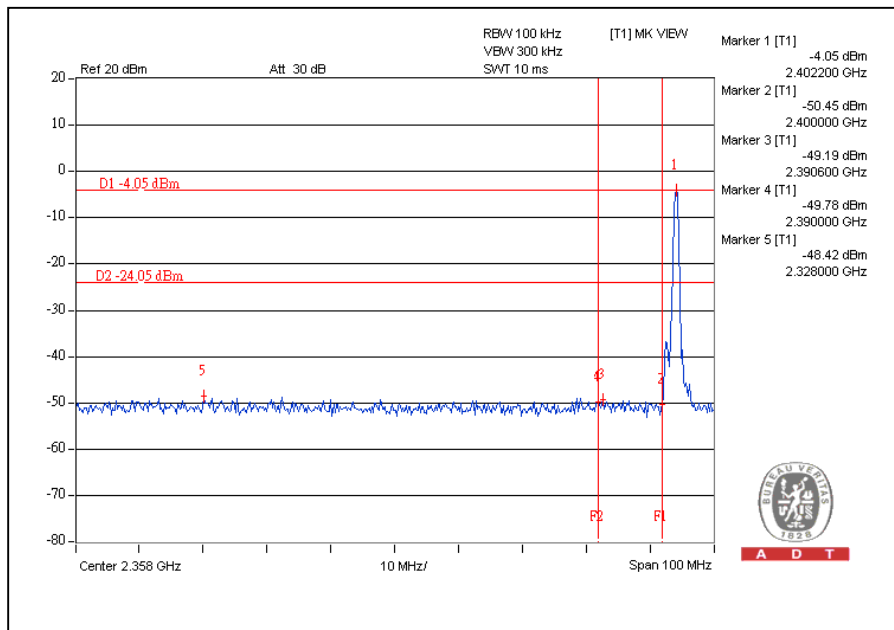

CH78

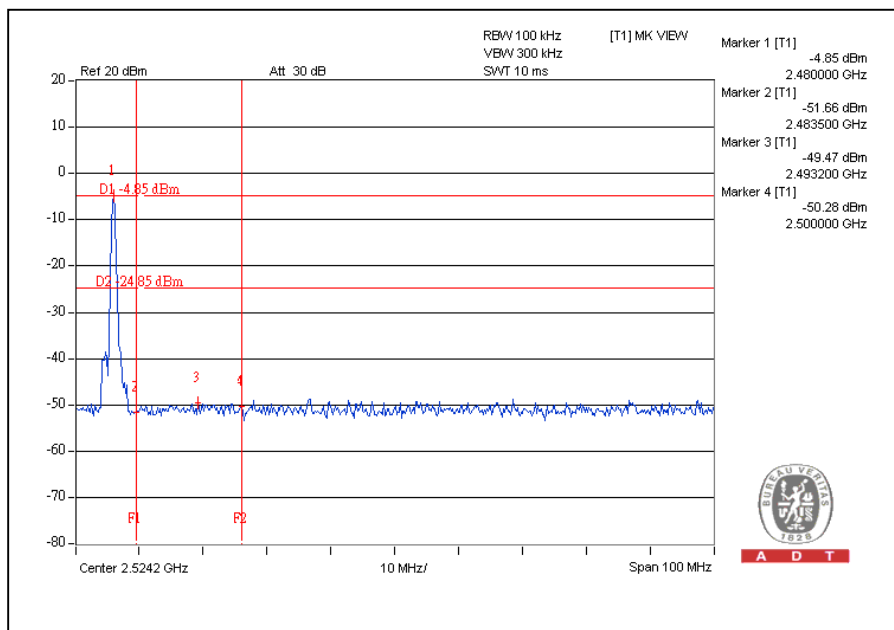



A D T

CH0

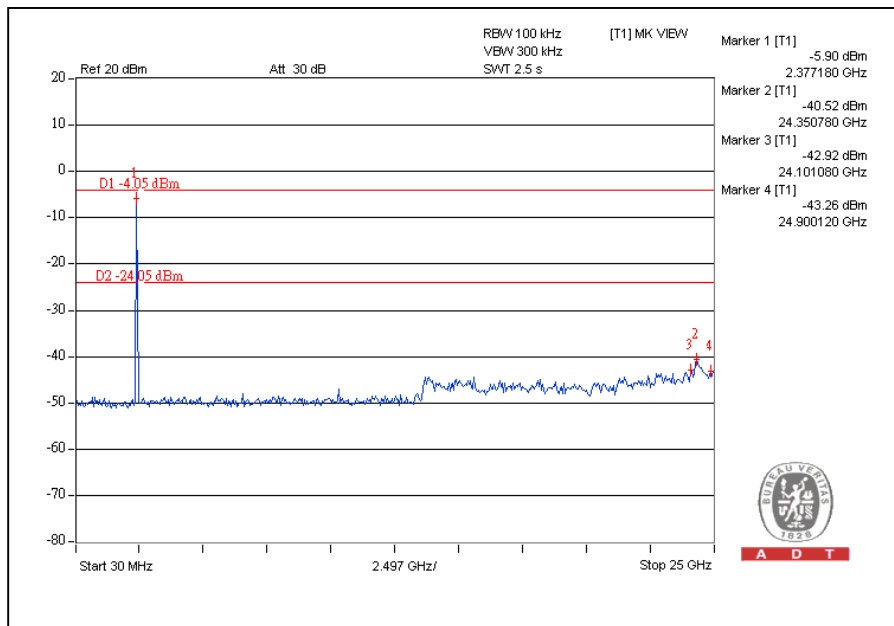

CH78

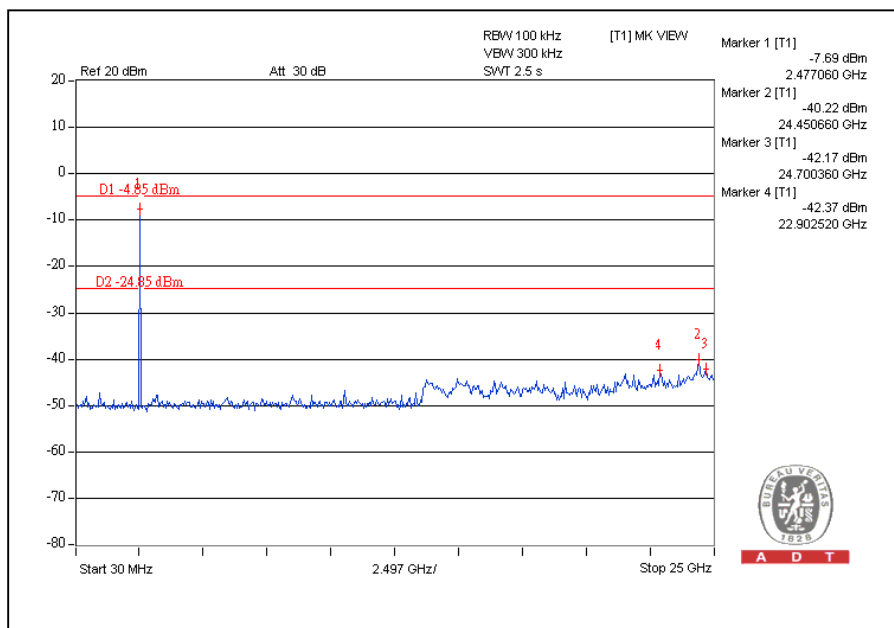



A D T

For 8DPSK Modulation Type:

CH0

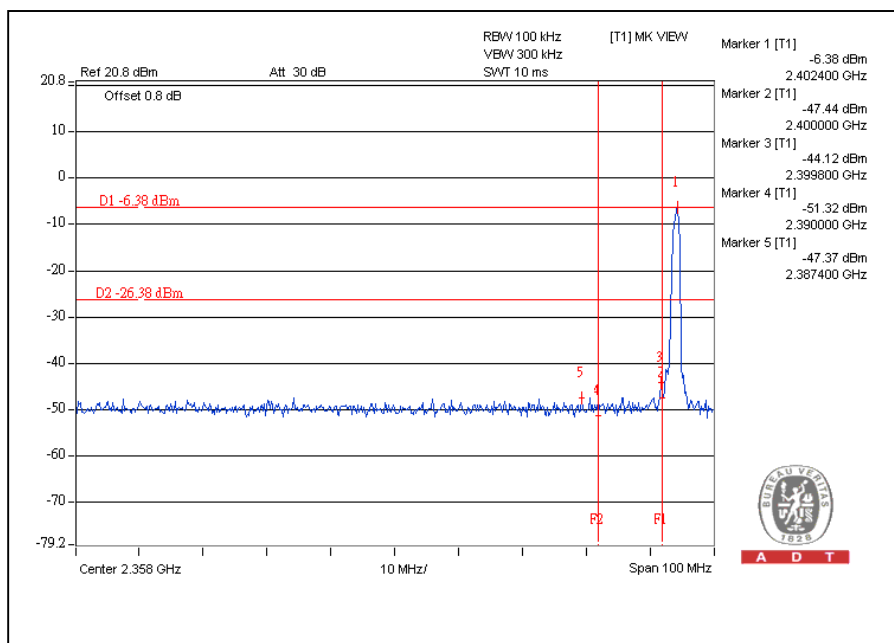

CH78

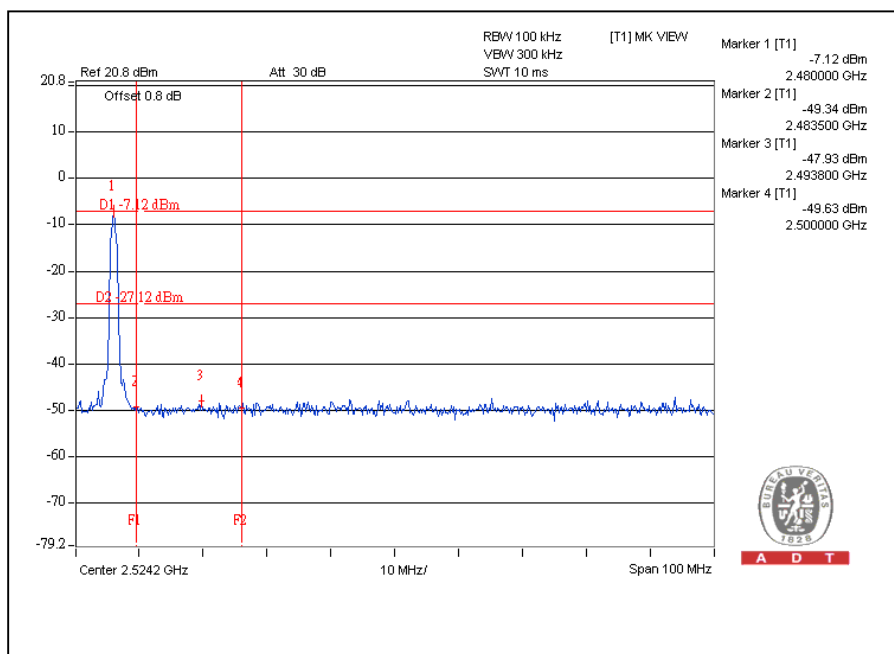



A D T

CH0

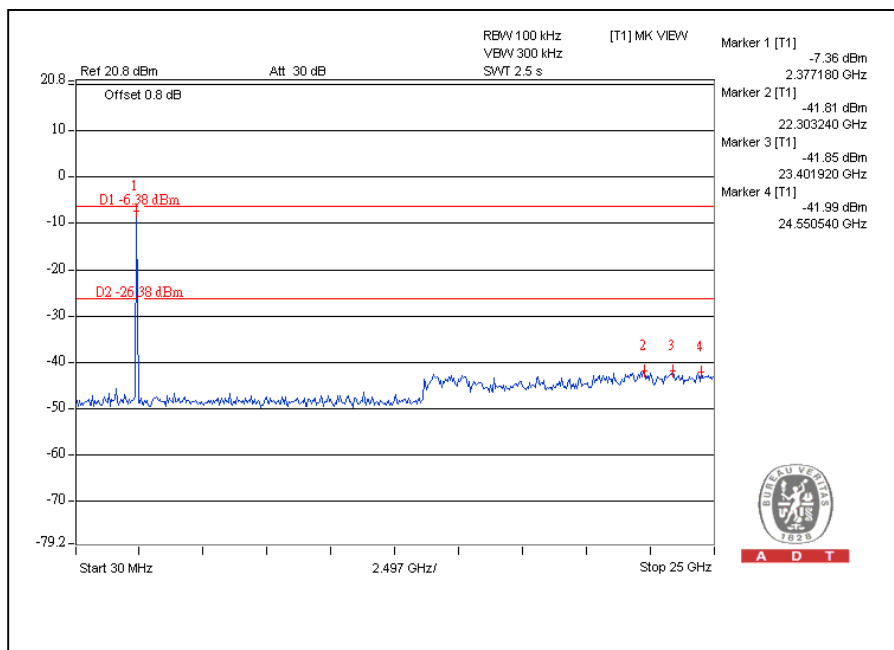

CH78

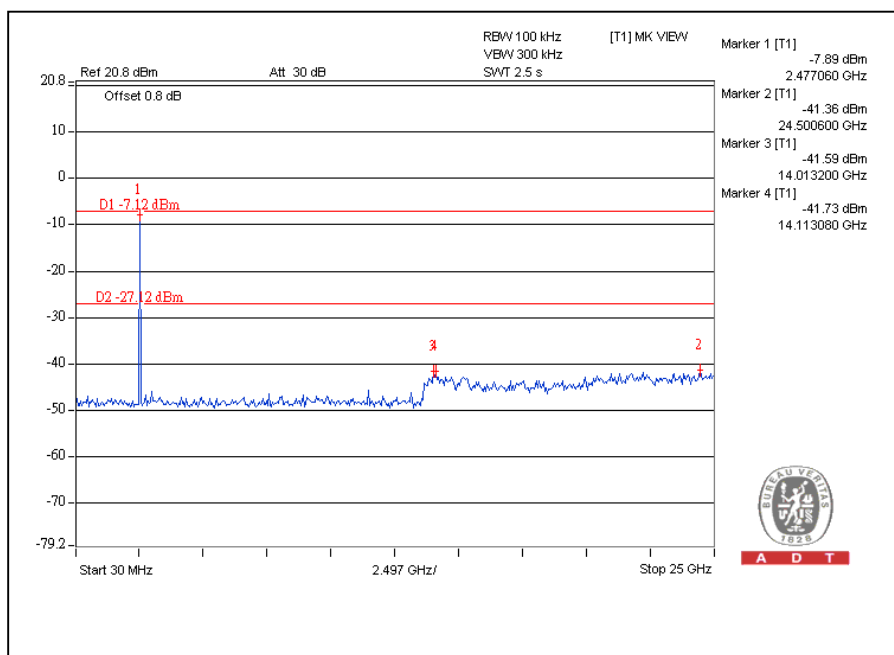



A D T

For $\pi/4$ -DQPSK Modulation Type:

CH0

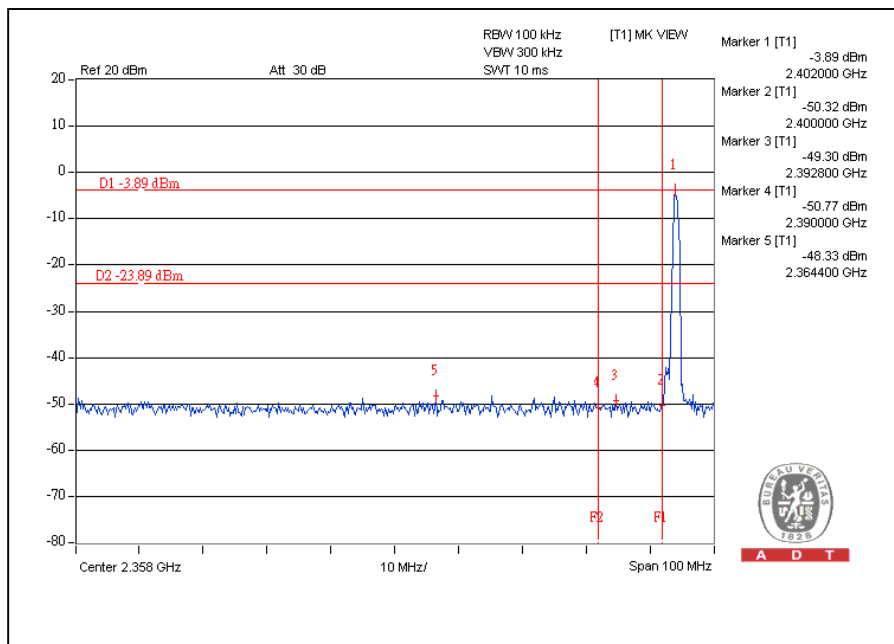

CH78

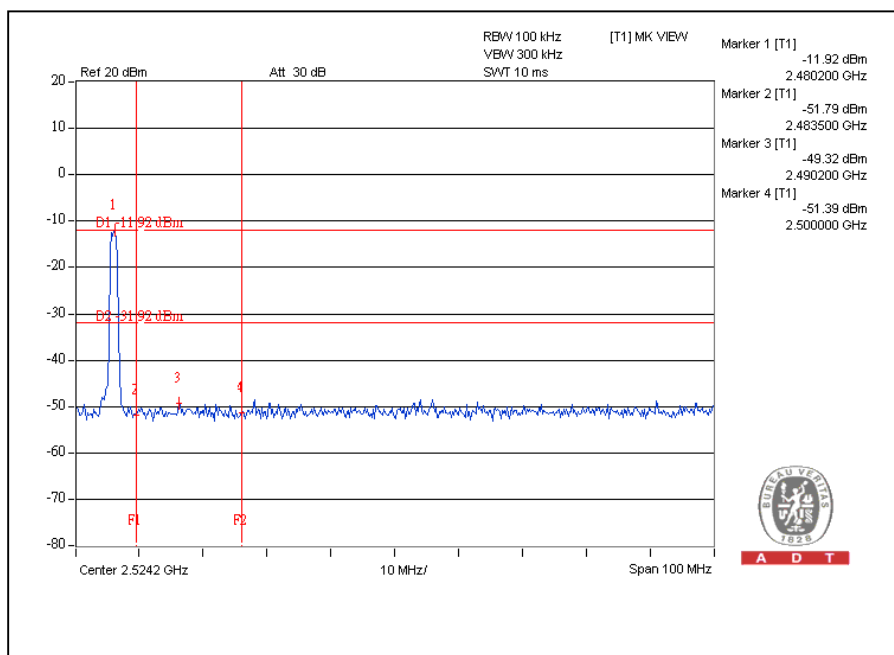



A D T

CH0

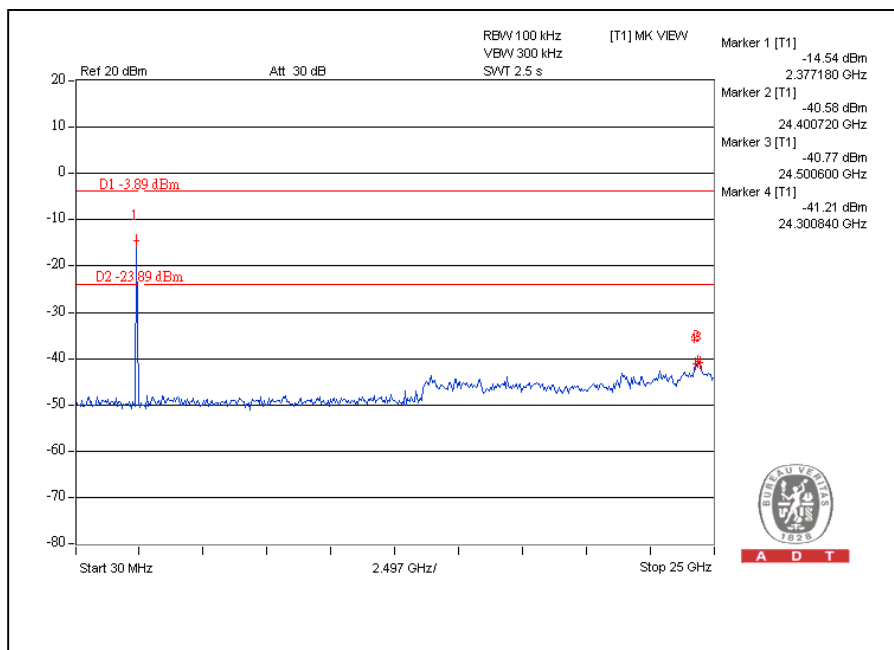

CH78

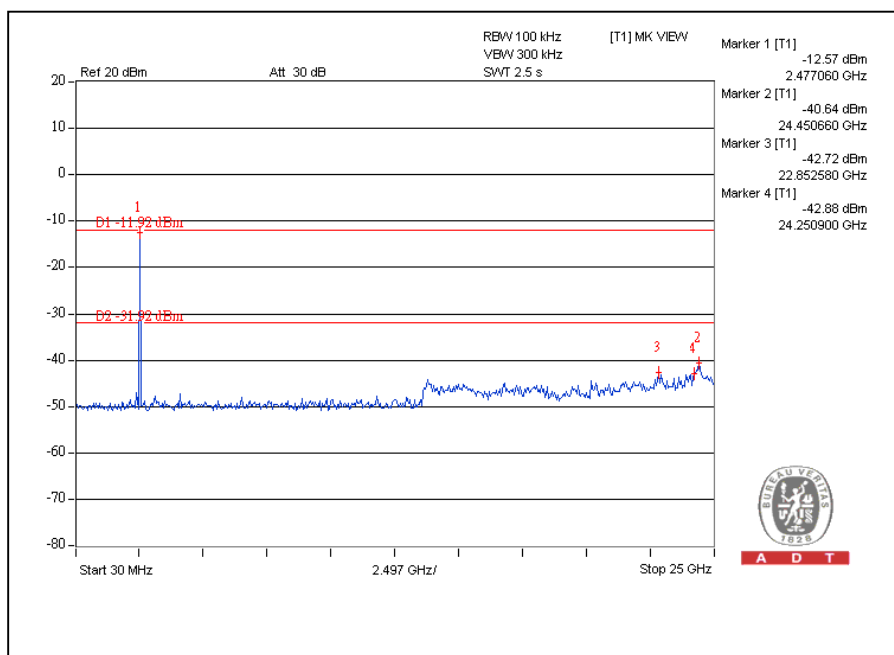



5 INFORMATION ON THE TESTING LABORATORIES

We, Bureau Veritas Consumer Products Services (H.K.) Ltd., Taoyuan Branch, were founded in 1988 to provide our best service in EMC, Radio, Telecom and Safety consultation. Our laboratories are accredited and approved according to ISO/IEC 17025:

Copies of accreditation certificates of our laboratories obtained from approval agencies can be downloaded from our web site: www.adt.com.tw/index.5/phtml.
If you have any comments, please feel free to contact us at the following:

Linko EMC/RF Lab:

Tel: 886-2-26052180

Fax: 886-2-26052943

Hsin Chu EMC/RF Lab:

Tel: 886-3-5935343

Fax: 886-3-5935342

Hwa Ya EMC/RF/Safety/Telecom Lab:

Tel: 886-3-3183232

Fax: 886-3-3185050

Email: service@adt.com.tw

Web Site: www.adt.com.tw

The address and road map of all our labs can be found in our web site also.

6 APPENDIX A - MODIFICATIONS RECORDERS FOR ENGINEERING CHANGES TO THE EUT BY THE LAB

No any modifications are made to the EUT by the lab during the test.

--- END ---