

FCC TEST REPORT

REPORT NO.: RF970311H02

MODEL NO.: W443D, LCS-WR5-2214N1, ENHWI-N, WFN-44

RECEIVED: March 11, 2008

TESTED: March 12 to April 09, 2008

ISSUED: June 20, 2008

APPLICANT: NETRONIX, INC.

ADDRESS: No. 945, Boai St., Jubei City, Hsin-Chu, 302,
Taiwan, R.O.C.

ISSUED BY: Advance Data Technology Corporation

TEST LOCATION: No. 81-1, Lu Liao Keng, 9 Ling, Wu Lung
Tsuen, Chiung Lin Hsiang, Hsin Chu Hsien,
Taiwan, R.O.C.

This test report consists of 102 pages in total. It may be duplicated completely for legal use with the approval of the applicant. It should not be reproduced except in full, without the written approval of our laboratory. The client should not use it to claim product endorsement by TAF, A2LA or any government agencies. The test results in the report only apply to the tested sample.



Table of Contents

1.	CERTIFICATION	4
2.	SUMMARY OF TEST RESULTS	5
2.1	MEASUREMENT UNCERTAINTY	6
3.	GENERAL INFORMATION	7
3.1	GENERAL DESCRIPTION OF EUT	7
3.2	DESCRIPTION OF TEST MODES	9
3.2.1	TEST MODE APPLICABILITY AND TESTED CHANNEL DETAIL:	10
3.3	GENERAL DESCRIPTION OF APPLIED STANDARDS	13
3.4	DESCRIPTION OF SUPPORT UNITS	14
3.5	CONFIGURATION OF SYSTEM UNDER TEST	15
4.	TEST TYPES AND RESULTS	16
4.1	CONDUCTED EMISSION MEASUREMENT	16
4.1.1	LIMITS OF CONDUCTED EMISSION MEASUREMENT	16
4.1.2	TEST INSTRUMENTS	16
4.1.3	TEST PROCEDURES	17
4.1.4	DEVIATION FROM TEST STANDARD	17
4.1.5	TEST SETUP	18
4.1.6	EUT OPERATING CONDITIONS	18
4.1.7	TEST RESULTS	19
4.2	RADIATED EMISSION MEASUREMENT	21
4.2.1	LIMITS OF RADIATED EMISSION MEASUREMENT	21
4.2.2	TEST INSTRUMENTS	22
4.2.3	TEST PROCEDURES	23
4.2.4	DEVIATION FROM TEST STANDARD	23
4.2.5	TEST SETUP	24
4.2.6	EUT OPERATING CONDITIONS	24
4.2.7	TEST RESULTS	25
4.3	6dB BANDWIDTH MEASUREMENT	54
4.3.1	LIMITS OF 6dB BANDWIDTH MEASUREMENT	54
4.3.2	TEST INSTRUMENTS	54
4.3.3	TEST PROCEDURE	55
4.3.4	DEVIATION FROM TEST STANDARD	55
4.3.5	TEST SETUP	55
4.3.6	EUT OPERATING CONDITIONS	55
4.3.7	TEST RESULTS	56
4.4	MAXIMUM PEAK OUTPUT POWER	68



4.4.1	LIMITS OF MAXIMUM PEAK OUTPUT POWER MEASUREMENT	68
4.4.2	INSTRUMENTS	68
4.4.3	TEST PROCEDURES.....	69
4.4.4	DEVIATION FROM TEST STANDARD	69
4.4.5	TEST SETUP	69
4.4.6	EUT OPERATING CONDITIONS.....	69
4.4.7	TEST RESULTS.....	70
4.5	POWER SPECTRAL DENSITY MEASUREMENT.....	72
4.5.1	LIMITS OF POWER SPECTRAL DENSITY MEASUREMENT	72
4.5.2	TEST INSTRUMENTS	72
4.5.3	TEST PROCEDURE	73
4.5.4	DEVIATION FROM TEST STANDARD	73
4.5.5	TEST SETUP	73
4.5.6	EUT OPERATING CONDITION	73
4.5.7	TEST RESULTS.....	74
4.6	BAND EDGES MEASUREMENT	86
4.6.1	LIMITS OF BAND EDGES MEASUREMENT	86
4.6.2	TEST INSTRUMENTS	86
4.6.3	TEST PROCEDURE	86
4.6.4	DEVIATION FROM TEST STANDARD	87
4.6.5	EUT OPERATING CONDITION	87
4.6.6	TEST RESULTS.....	87
4.7	ANTENNA REQUIREMENT	100
4.7.1	STANDARD APPLICABLE	100
4.7.2	ANTENNA CONNECTED CONSTRUCTION	100
5.	INFORMATION ON THE TESTING LABORATORIES	101
6.	APPENDIX A - MODIFICATIONS RECORDERS FOR ENGINEERING CHANGES TO THE EUT BY THE LAB	102



1. CERTIFICATION

PRODUCT: IEEE802.11n Wireless Router
BRAND NAME: NETRONIX, Longshine, Encore, ViSTOR
MODEL NO.: W443D, LCS-WR5-2214N1, ENHWI-N, WFN-44
TEST SAMPLE: MASS-PRODUCTION
TESTED: March 12 to April 09, 2008
APPLICANT: NETRONIX, INC.
STANDARDS: FCC Part 15, Subpart C (Section 15.247),
ANSI C63.4-2003

The above equipment (Model: W443D) has been tested by **Advance Data Technology Corporation**, and found compliance with the requirement of the above standards. The test record, data evaluation & Equipment Under Test (EUT) configurations represented herein are true and accurate accounts of the measurements of the sample's EMC characteristics under the conditions specified in this report.

PREPARED BY : *Sunny Wen* , **DATE:** June 20, 2008
(Sunny Wen, Specialist)

TECHNICAL ACCEPTANCE : *Hank Chung* , **DATE:** June 20, 2008
Responsible for RF (Hank Chung, Deputy Manager)

APPROVED BY : *May Chen* , **DATE:** June 20, 2008
(May Chen, Deputy Manager)

2. SUMMARY OF TEST RESULTS

The EUT has been tested according to the following specifications:

APPLIED STANDARD: FCC Part 15, Subpart C (Section 15.247)			
Standard Section	Test Type and Limit	Result	Remark
15.207	AC Power Conducted Emission	PASS	Meet the requirement of limit. Minimum passing margin is -8.80dB at 0.158MHz
15.247(a)(2)	Spectrum Bandwidth of a Direct Sequence Spread Spectrum System Limit: min. 500kHz	PASS	Meet the requirement of limit.
15.247(b)	Maximum Peak Output Power Limit: max. 30dBm	PASS	Meet the requirement of limit.
15.247(d)	Radiated Emissions Limit: Table 15.209	PASS	Meet the requirement of limit. Minimum passing margin is -0.50dB at 2483.50MHz
15.247(e)	Power Spectral Density Limit: max. 8dBm	PASS	Meet the requirement of limit.
15.247(d)	Band Edge Measurement Limit: 20dB less than the peak value of fundamental frequency	PASS	Meet the requirement of limit.

2.1 MEASUREMENT UNCERTAINTY

Where relevant, the following measurement uncertainty levels have been estimated for tests performed on the EUT as specified in CISPR 16-4:

This uncertainty represents an expanded uncertainty expressed at approximately the 95% confidence level using a coverage factor of $k=2$.

Measurement	Value
Conducted emissions	2.44 dB
Radiated emissions (30MHz-1GHz)	3.94 dB
Radiated emissions (1GHz -18GHz)	2.33 dB
Radiated emissions (18GHz -40GHz)	2.55 dB

3. GENERAL INFORMATION

3.1 GENERAL DESCRIPTION OF EUT

PRODUCT	IEEE802.11n Wireless Router
MODEL NO.	W443D, LCS-WR5-2214N1, ENHWI-N, WFN-44
FCC ID	NOI-W443D
POWER SUPPLY	DC 12V from power adapter
MODULATION TYPE	CCK, DQPSK, DBPSK for DSSS 64QAM, 16QAM, QPSK, BPSK for OFDM
MODULATION TECHNOLOGY	DSSS, OFDM
TRANSFER RATE	802.11b: 11/ 5.5/ 2/ 1Mbps 802.11g: 54/ 48/ 36/ 24/ 18/ 12/ 9/ 6Mbps Draft 802.11n (20MHz): 144.4/130.0/115.5/86.6/ 72.2/65.0/57.8/43.3/28.9/21.7/14.4/7.2Mbps Draft 802.11n (40MHz): 300/ 270/ 240/ 180/150/135/120/90/60/45/30/15Mbps
FREQUENCY RANGE	2412 ~ 2462MHz
NUMBER OF CHANNEL	11 for 802.11b, 802.11g, draft 802.11n (20MHz) 7 for draft 802.11n (40MHz)
MAXIMUM OUTPUT POWER	802.11b: 18.197mW 802.11g: 54.954mW draft 802.11n (20MHz): 104.962mW draft 802.11n (40MHz): 76.059mW
ANTENNA TYPE	Please see note 1 (on next page)
DATA CABLE	NA
I/O PORT	WAN Port x 1, LAN Port x 4

NOTE:

1. There are three antennas provided to this EUT, please refer to the following table:

Transmitter Circuit	Antenna Type	Antenna Connector	Gain(dBi)
Chain(0)	Dipole	REVERSE SMA	2
Chain(1)	Dipole	REVERSE SMA	2
Chain(2)	Dipole	REVERSE SMA	2

2. The EUT has four brand names and four model names, which are identical to each other in all aspects except for the following:

Brand	Model Name
NETRONIX	W443D
Longshine	LCS-WR5-2214N1
Encore	ENHWI-N
ViSTOR	WFN-44

From the above models, model: **W443D** was selected as representative model for the test and its data was recorded in this report.

3. The EUT was operated with the following power adapter :

Brand:	HONGHUI
Model No.:	CGS-1201000
Input power :	AC 100-240V, 50/60Hz, 1.0A
Output power :	DC 12V Cable:1.8m/unshielded/without core

4. The EUT incorporates a MIMO function with 802.11b, 802.11g, draft 802.11n. Physically, the EUT provides two completed transmit and three completed receivers.
5. The EUT is 2 * 3 spatial MIMO without beam forming function. The antenna configurations are two transmitter antennas and three receiver antennas, as there are 3 Dipole antennas. Spatial multiplexing modes for simultaneous transmission using 2 antennas, and for simultaneous receiver using 3 antennas. The 11bg legacy modes are limited to single transmitter only.
6. When the EUT operating in draft 802.11n, the software operation, which is defined by manufacturer, MCS (Modulation and Coding Schemes) from 0 to 15.
7. The EUT complies with draft 802.11n standards and backwards compatible with 802.11b, 802.11g products.
8. The EUT, operates in the 2.4GHz frequency range, lets you connect IEEE 802.11g or IEEE 802.11b and draft 802.11n technique devices to the network.
9. The above EUT information was declared by manufacturer and for more detailed features description, please refer to the manufacturer's specifications or user's manual.

3.2 DESCRIPTION OF TEST MODES

Eleven channels are provided for 802.11b, 802.11g, draft 802.11n (20MHz):

CHANNEL	FREQUENCY	CHANNEL	FREQUENCY
1	2412MHz	7	2442MHz
2	2417MHz	8	2447MHz
3	2422MHz	9	2452MHz
4	2427MHz	10	2457MHz
5	2432MHz	11	2462MHz
6	2437MHz		

Seven channels are provided for draft 802.11n (40MHz):

CHANNEL	FREQUENCY	CHANNEL	FREQUENCY
1	2422MHz	5	2442MHz
2	2427MHz	6	2447MHz
3	2432MHz	7	2452MHz
4	2437MHz		

3.2.1 TEST MODE APPLICABILITY AND TESTED CHANNEL DETAIL:

EUT CONFIGURE MODE	APPLICABLE TO				DESCRIPTION
	PLC	RE < 1G	RE ≥ 1G	APCM	
-	√	√	√	√	-

Where **PLC**: Power Line Conducted Emission

RE < 1G: Radiated Emission below 1GHz

RE ≥ 1G: Radiated Emission above 1GHz

APCM: Antenna Port Conducted Measurement

COMBINATION MODE:

ANTENNA COMBINATION MODE:

COMBINATION MODE	OPERATION MODE	TX CHAIN(0)	TX CHAIN(1)
A	802.11 b	√	
B	802.11 g	√	
C	DRAFT 802.11n(20MHz)	√	
D		√	√
E	DRAFT 802.11n(40MHz)	√	
F		√	√

Note:

1. The above information was declared by manufacturer and for more detailed features description, please refer to the manufacturer's specifications or user's manual.
2. From above mode, the different modes were chosen for pretest.
3. Mode A, B, D, F the worst modes, was selected as representative mode for the report.

POWER LINE CONDUCTED EMISSION TEST:

- Pre-Scan has been conducted to determine the worst-case mode from all possible combinations between available modulations, data rates and antenna ports (if EUT with antenna diversity architecture).
- Following channel(s) was (were) selected for the final test as listed below.

MODE	AVAILABLE CHANNEL	TESTED CHANNEL	MODULATION TECHNOLOGY	MODULATION TYPE	DATA RATE (Mbps)	TX COMBINATION
Draft 802.11n (20MHz)	1 to 11	6	OFDM	BPSK	14.4	D

RADIATED EMISSION TEST (BELOW 1 GHz):

- Pre-Scan has been conducted to determine the worst-case mode from all possible combinations between available modulations, data rates and antenna ports (if EUT with antenna diversity architecture).
- Following channel(s) was (were) selected for the final test as listed below.

MODE	AVAILABLE CHANNEL	TESTED CHANNEL	MODULATION TECHNOLOGY	MODULATION TYPE	DATA RATE (Mbps)	TX COMBINATION
Draft 802.11n (20MHz)	1 to 11	6	OFDM	BPSK	14.4	D

RADIATED EMISSION TEST (ABOVE 1 GHz):

- Pre-Scan has been conducted to determine the worst-case mode from all possible combinations between available modulations, data rates and antenna ports (if EUT with antenna diversity architecture).
- Following channel(s) was (were) selected for the final test as listed below.

MODE	AVAILABLE CHANNEL	TESTED CHANNEL	MODULATION TECHNOLOGY	MODULATION TYPE	DATA RATE (Mbps)	TX COMBINATION
802.11b	1 to 11	1, 6, 11	DSSS	DBPSK	1	A
802.11g	1 to 11	1, 6, 11	OFDM	BPSK	6	B
Draft 802.11n (20MHz)	1 to 11	1, 6, 11	OFDM	BPSK	14.4	D
Draft 802.11n (40MHz)	1 to 7	1, 4, 7	OFDM	BPSK	30	F

BANDEDGE MEASUREMENT:

- Pre-Scan has been conducted to determine the worst-case mode from all possible combinations between available modulations, data rates and antenna ports (if EUT with antenna diversity architecture).
- Following channel(s) was (were) selected for the final test as listed below.

MODE	AVAILABLE CHANNEL	TESTED CHANNEL	MODULATION TECHNOLOGY	MODULATION TYPE	DATA RATE (Mbps)	TX COMBINATION
802.11b	1 to 11	1, 11	DSSS	DBPSK	1	A
802.11g	1 to 11	1, 11	OFDM	BPSK	6	B
Draft 802.11n (20MHz)	1 to 11	1, 11	OFDM	BPSK	14.4	D
Draft 802.11n (40MHz)	1 to 7	1, 7	OFDM	BPSK	30	F

ANTENNA PORT CONDUCTED MEASUREMENT:

- Pre-Scan has been conducted to determine the worst-case mode from all possible combinations between available modulations, data rates and antenna ports (if EUT with antenna diversity architecture).
- Following channel(s) was (were) selected for the final test as listed below.

MODE	AVAILABLE CHANNEL	TESTED CHANNEL	MODULATION TECHNOLOGY	MODULATION TYPE	DATA RATE (Mbps)	TX COMBINATION
802.11b	1 to 11	1, 6, 11	DSSS	CCK	11	A
802.11g	1 to 11	1, 6, 11	OFDM	BPSK	6	B
Draft 802.11n (20MHz)	1 to 11	1, 6, 11	OFDM	BPSK	14.4	D
Draft 802.11n (40MHz)	1 to 7	1, 4, 7	OFDM	BPSK	30	F



3.3 GENERAL DESCRIPTION OF APPLIED STANDARDS

The EUT is an IEEE802.11n Wireless Router. According to the specifications of the manufacturer, it must comply with the requirements of the following standards:

FCC Part 15, Subpart C. (15.247)

ANSI C63.4-2003

All test items have been performed and recorded as per the above standards.

NOTE: The EUT is also considered as a kind of computer peripheral, because the connection to computer is necessary for typical use. It has been verified to comply with the requirements of FCC Part 15, Subpart B, Class B (DoC). The test report has been issued separately.



3.4 DESCRIPTION OF SUPPORT UNITS

The EUT has been tested as an independent unit together with other necessary accessories or support units. The following support units or accessories were used to form a representative test configuration during the tests.

NO.	PRODUCT	BRAND	MODEL NO.	SERIAL NO.	FCC ID
1	NOTEBOOK COMPUTER	DELL	PP05L	CN-04Y212-48643-38E-0145	DoC
2	NOTEBOOK COMPUTER	DELL	PP19L	CN-OHC416-70166-5CA-0448	PIW632500516610
3	HUB	AVSYS	110H8	01-20E-000002	DoC

NO.	SIGNAL CABLE DESCRIPTION OF THE ABOVE SUPPORT UNITS
1	NA
2	NA
3	NA

NOTE: All power cords of the above support units are non shielded (1.8m).

3.5 CONFIGURATION OF SYSTEM UNDER TEST

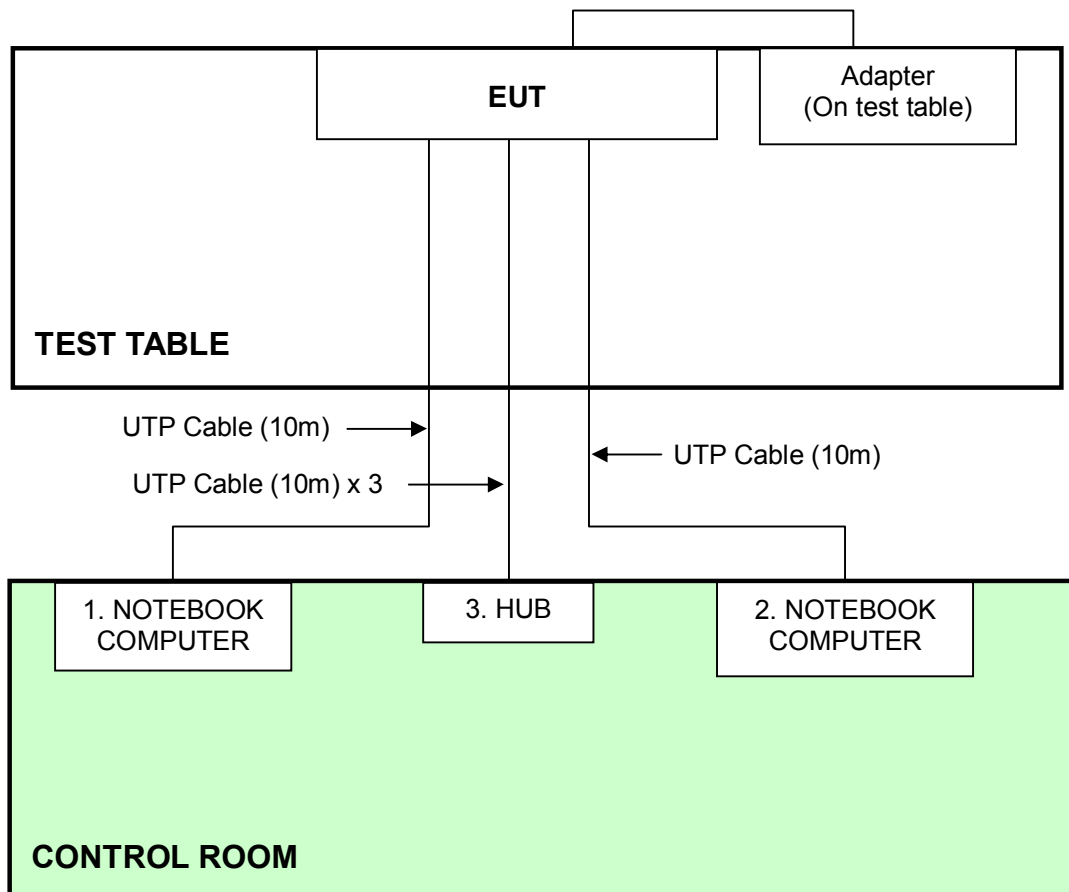

4. TEST TYPES AND RESULTS

4.1 CONDUCTED EMISSION MEASUREMENT

4.1.1 LIMITS OF CONDUCTED EMISSION MEASUREMENT

FREQUENCY OF EMISSION (MHz)	CONDUCTED LIMIT (dB μ V)	
	Quasi-peak	Average
0.15-0.5	66 to 56	56 to 46
0.5-5	56	46
5-30	60	50

- NOTE:**
1. The lower limit shall apply at the transition frequencies.
 2. The limit decreases in line with the logarithm of the frequency in the range of 0.15 to 0.50 MHz.
 3. All emanations from a class A/B digital device or system, including any network of conductors and apparatus connected thereto, shall not exceed the level of field strengths specified above.

4.1.2 TEST INSTRUMENTS

DESCRIPTION & MANUFACTURER	MODEL NO.	SERIAL NO.	CALIBRATED UNTIL
ROHDE & SCHWARZ Test Receiver	ESCS 30	100287	Mar. 06, 2009
Line-Impedance Stabilization Network(for EUT)	KNW-407	8-1395-12	Aug. 19, 2008
Line-Impedance Stabilization Network(for Peripheral)	ENV-216	100072	Nov. 08, 2008
RF Cable (JETBAO)	RG5B/U-6m	COACAB-9KHz-3 0MHz	Aug. 15, 2008
50 ohms Terminator	50	3	Nov. 15, 2008
Software	ADT_Cond_V7.3.2	NA	NA

- NOTE:**
1. The calibration interval of the above test instruments is 12 months and the calibrations are traceable to NML/ROC and NIST/USA.
 2. The test was performed in ADT Shielded Room No. A.
 3. The VCCI Con A Registration No. is C-817.

4.1.3 TEST PROCEDURES

- a. The EUT was placed 0.4 meters from the conducting wall of the shielded room with EUT being connected to the power mains through a line impedance stabilization network (LISN). Other support units were connected to the power mains through another LISN. The two LISNs provide 50 ohm/ 50uH of coupling impedance for the measuring instrument.
- b. Both lines of the power mains connected to the EUT were checked for maximum conducted interference.
- c. The frequency range from 150kHz to 30MHz was searched. Emission levels under (Limit - 20dB) were not recorded.

4.1.4 DEVIATION FROM TEST STANDARD

No deviation

4.1.5 TEST SETUP

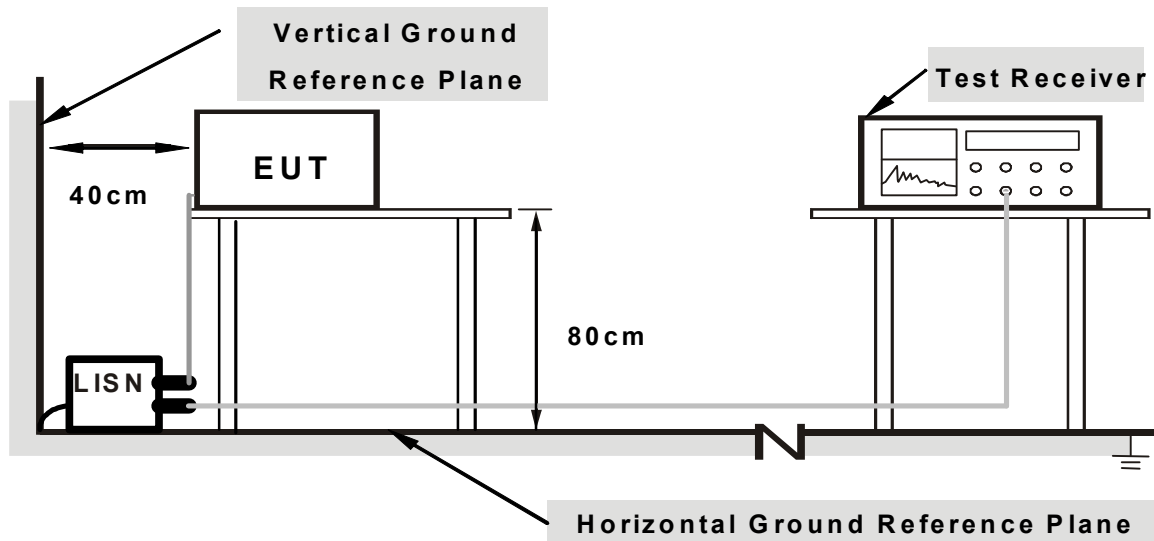

Note: 1. Support units were connected to second LISN.

2. Both of LISNs (AMN) are 80 cm from EUT and at least 80 from other units and other metal planes

For the actual test configuration, please refer to the related item – Photographs of the Test Configuration.

4.1.6 EUT OPERATING CONDITIONS

1. Placed the EUT on testing table.
2. Prepared other computer systems (support unit 1 ~ 2) to act as communication partners and placed them outside of testing area.
3. The communication partners run test program “RaLink RTL2880” to enable EUT under transmission/receiving condition continuously at specific channel frequency.

4.1.7 TEST RESULTS

DRAFT 802.11n (20MHz) OFDM MODULATION

EUT TEST CONDITION		MEASUREMENT DETAIL	
CHANNEL	Channel 6	PHASE	Line (L)
MODULATION TYPE	BPSK	6dB BANDWIDTH	9 kHz
TRANSFER RATE	14.4Mbps	INPUT POWER	120Vac, 60 Hz
ENVIRONMENTAL CONDITIONS	25deg. C, 70%RH, 972hPa	TESTED BY	Andy Ho

No	Freq. [MHz]	Corr. Factor (dB)	Reading Value [dB (uV)]		Emission Level [dB (uV)]		Limit [dB (uV)]		Margin (dB)	
			Q.P.	AV.	Q.P.	AV.	Q.P.	AV.	Q.P.	AV.
	1	0.158	0.35	56.43	43.22	56.78	43.57	65.58	55.58	-8.80
2	0.210	0.33	48.80	-	49.13	-	63.20	53.20	-14.07	-
3	0.449	0.12	37.17	-	37.29	-	56.89	46.89	-19.60	-
4	3.092	0.35	35.72	-	36.07	-	56.00	46.00	-19.93	-
5	13.422	0.76	33.35	-	34.11	-	60.00	50.00	-25.89	-
6	22.457	0.92	39.62	-	40.54	-	60.00	50.00	-19.46	-

- REMARKS:**
1. Q.P. and AV. are abbreviations of quasi-peak and average individually.
 2. "-": The Quasi-peak reading value also meets average limit and measurement with the average detector is unnecessary.
 3. The emission levels of other frequencies were very low against the limit.
 4. Margin value = Emission level - Limit value
 5. Correction factor = Insertion loss + Cable loss
 6. Emission Level = Correction Factor + Reading Value.

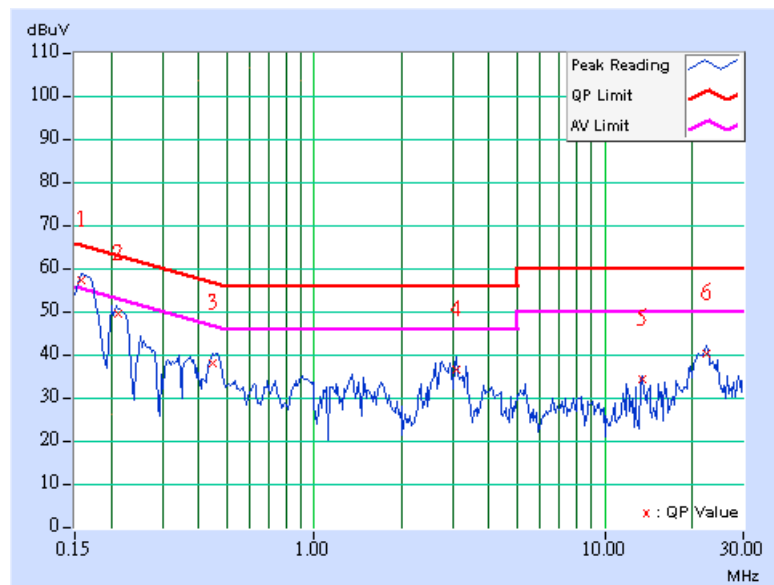

EUT TEST CONDITION		MEASUREMENT DETAIL	
CHANNEL	Channel 6	PHASE	Neutral (N)
MODULATION TYPE	BPSK	6dB BANDWIDTH	9 kHz
TRANSFER RATE	14.4Mbps	INPUT POWER	120Vac, 60 Hz
ENVIRONMENTAL CONDITIONS	25deg. C, 70%RH, 972hPa	TESTED BY	Andy Ho

No	Freq. [MHz]	Corr. Factor (dB)	Reading Value [dB (uV)]		Emission Level [dB (uV)]		Limit [dB (uV)]		Margin (dB)	
			Q.P.	AV.	Q.P.	AV.	Q.P.	AV.	Q.P.	AV.
	1	0.159	0.37	54.63	-	55.00	-	65.49	55.49	-10.49
2	0.213	0.34	46.10	-	46.44	-	63.11	53.11	-16.66	-
3	0.468	0.12	38.03	-	38.15	-	56.55	46.55	-18.40	-
4	3.128	0.35	34.47	-	34.82	-	56.00	46.00	-21.18	-
5	6.780	0.47	28.92	-	29.39	-	60.00	50.00	-30.61	-
6	23.129	0.93	42.96	-	43.89	-	60.00	50.00	-16.11	-

- REMARKS:**
1. Q.P. and AV. are abbreviations of quasi-peak and average individually.
 2. "-": The Quasi-peak reading value also meets average limit and measurement with the average detector is unnecessary.
 3. The emission levels of other frequencies were very low against the limit.
 4. Margin value = Emission level - Limit value
 5. Correction factor = Insertion loss + Cable loss
 6. Emission Level = Correction Factor + Reading Value.

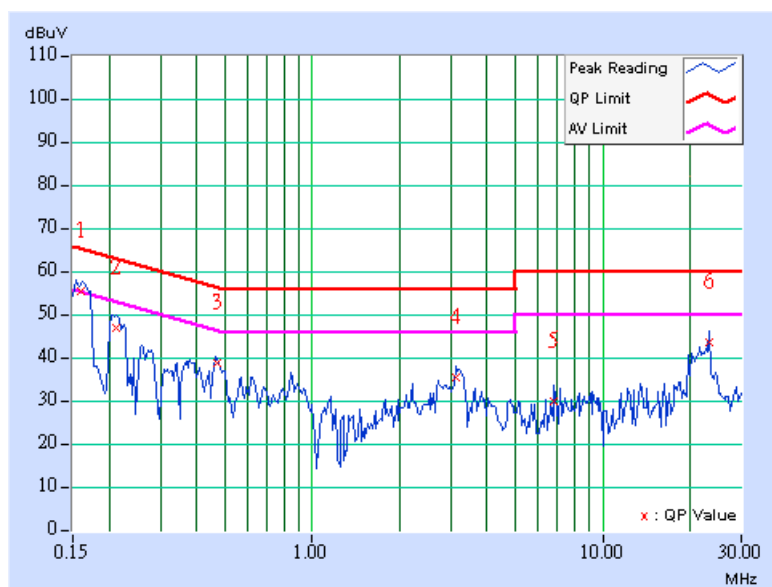

4.2 RADIATED EMISSION MEASUREMENT

4.2.1 LIMITS OF RADIATED EMISSION MEASUREMENT

Emissions radiated outside of the specified bands, shall be according to the general radiated limits in 15.209 as following:

Frequencies (MHz)	Field strength (microvolts/meter)	Measurement distance (meters)
0.009-0.490	2400/F(kHz)	300
0.490-1.705	24000/F(kHz)	30
1.705-30.0	30	30
30-88	100	3
88-216	150	3
216-960	200	3
Above 960	500	3

NOTE:

1. The lower limit shall apply at the transition frequencies.
2. Emission level (dBuV/m) = 20 log Emission level (uV/m).
3. As shown in 15.35(b), for frequencies above 1000MHz, the field strength limits are based on average detector, however, the peak field strength of any emission shall not exceed the maximum permitted average limits, specified above by more than 20dB under any condition of modulation.



4.2.2 TEST INSTRUMENTS

DESCRIPTION & MANUFACTURER	MODEL NO.	SERIAL NO.	CALIBRATED UNTIL
ADVANTEST Spectrum Analyzer	R3271A	85060311	July 15, 2008
HP Pre_Amplifier	8449B	3008A01922	Oct. 04, 2008
ROHDE & SCHWARZ Test Receiver	ESCS30	100375	Mar. 26, 2009
SCHWARZBECK TRILOG Broadband Antenna	VULB 9168	138	July 26, 2008
Schwarzbeck Horn_Antenna	BBHA9120	D124	Dec. 16, 2008
Schwarzbeck Horn_Antenna	BBHA 9170	BBHA9170153	Jan. 27, 2009
RF Switches (ARNITSU)	CS-201	1565157	Aug. 13, 2008
RF CABLE (Chaintek)	SF102	22054-2	Dec. 06. 2008
RF Cable(RICHTEC)	9913-30M N-N Cable	STCCAB-30M-1 GHz	Aug. 13, 2008
Software	ADT_Radiated_V 7.6.15.8	NA	NA
CHANCE MOST Antenna Tower	AT-100	0203	NA
CHANCE MOST Turn Table	TT-100	0203	NA

- Note: 1. The calibration interval of the above test instruments is 12 months and the calibrations are traceable to NML/ROC and NIST/USA.
2. The horn antenna, HP preamplifier (model: 8449B) and Spectrum Analyzer (model: R3271A) are used only for the measurement of emission frequency above 1GHz if tested.
3. The test was performed in ADT Open Site No. C.
4. The FCC Site Registration No. is 656396.
5. The VCCI Site Registration No. is R-1626.
6. The CANADA Site Registration No. is IC 4824A-3.

4.2.3 TEST PROCEDURES

- a. The EUT was placed on the top of a rotating table 0.8 meters above the ground at a 10-meter open field site. The table was rotated 360 degrees to determine the position of the highest radiation.
- b. The EUT was set 3 meters away from the interference-receiving antenna, which was mounted on the top of a variable-height antenna tower.
- c. The antenna is a broadband antenna, and its height is varied from one meter to four meters above the ground to determine the maximum value of the field strength. Both horizontal and vertical polarizations of the antenna are set to make the measurement.
- d. For each suspected emission, the EUT was arranged to its worst case and then the antenna was tuned to heights from 1 meter to 4 meters and the rotatable table was turned from 0 degrees to 360 degrees to find the maximum reading.
- e. The test-receiver system was set to Peak Detect Function and Specified Bandwidth with Maximum Hold Mode.
- f. If the emission level of the EUT in peak mode was 10 dB lower than the limit specified, then testing could be stopped and the peak values of the EUT would be reported. Otherwise the emissions that did not have 10 dB margin would be re-tested one by one using the quasi-peak method or average method as specified and then reported in Data sheet peak mode and QP mode.

NOTE:

1. The resolution bandwidth and video bandwidth of test receiver/spectrum analyzer is 120kHz for Peak detection (PK) and Quasi-peak detection (QP) at frequency below 1GHz.
2. The resolution bandwidth of test receiver/spectrum analyzer is 1 MHz and the video bandwidth is 3 MHz for Peak detection (PK) at frequency above 1GHz.
3. The resolution bandwidth of test receiver/spectrum analyzer is 1 MHz and the video bandwidth is 10 Hz for Average detection (AV) at frequency above 1GHz.

4.2.4 DEVIATION FROM TEST STANDARD

No deviation

4.2.5 TEST SETUP

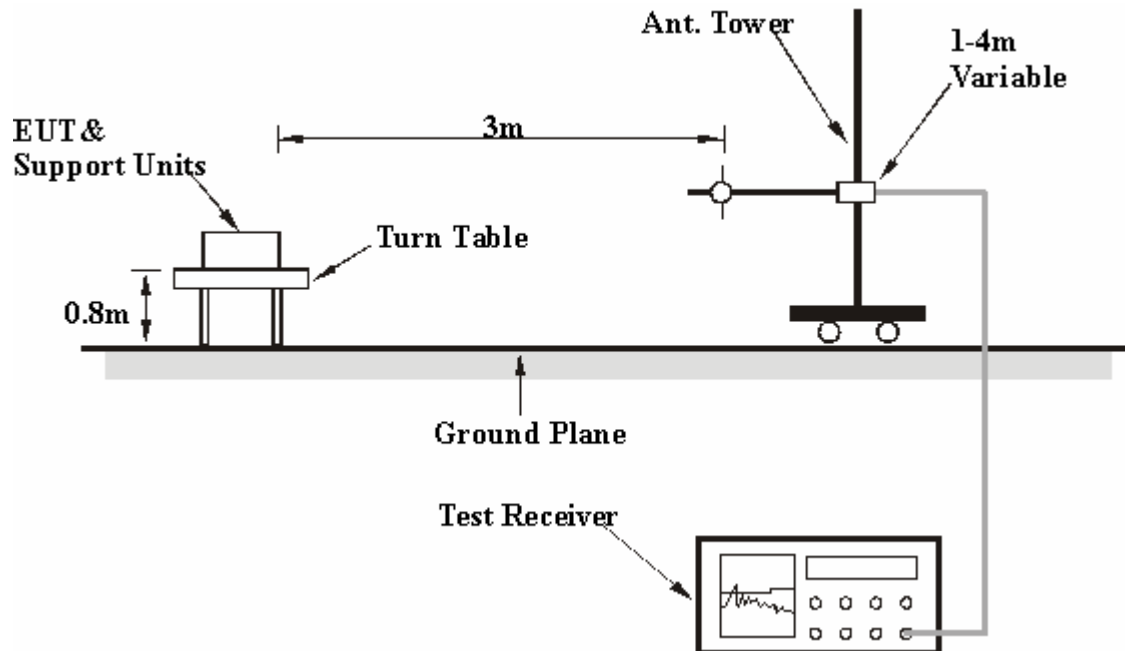

For the actual test configuration, please refer to the related item – Photographs of the Test Configuration.

4.2.6 EUT OPERATING CONDITIONS

Same as 4.1.6

4.2.7 TEST RESULTS

BELOW 1GHz WORST-CASE DATA : DRAFT 802.11n (20MHz) OFDM MODULATION

EUT TEST CONDITION		MEASUREMENT DETAIL	
CHANNEL	Channel 6	FREQUENCY RANGE	Below 1000MHz
INPUT POWER (SYSTEM)	120Vac, 60 Hz	DETECTOR FUNCTION	Quasi-Peak
ENVIRONMENTAL CONDITIONS	24deg. C, 62%RH 972hPa	TESTED BY	Sky Liao

ANTENNA POLARITY & TEST DISTANCE: HORIZONTAL AT 3 M								
NO.	FREQ. (MHz)	EMISSION LEVEL (dBuV/m)	LIMIT (dBuV/m)	MARGIN (dB)	ANTENNA HEIGHT (m)	TABLE ANGLE (Degree)	RAW VALUE (dBuV)	CORRECTION FACTOR (dB/m)
1	125.00	29.86 QP	43.50	-13.64	1.36 H	256	16.63	13.23
2	250.00	26.62 QP	46.00	-19.38	1.00 H	274	13.79	12.83
3	375.00	26.63 QP	46.00	-19.37	1.00 H	21	9.15	17.48
4	500.00	26.78 QP	46.00	-19.22	1.62 H	183	5.73	21.05
5	600.00	24.43 QP	46.00	-21.57	1.30 H	139	0.89	23.54
6	750.00	29.53 QP	46.00	-16.47	1.20 H	79	2.27	27.26
7	799.99	33.03 QP	46.00	-12.97	1.81 H	182	4.98	28.05
8	874.99	27.00 QP	46.00	-19.00	1.76 H	202	-2.07	29.07
ANTENNA POLARITY & TEST DISTANCE: VERTICAL AT 3 M								
NO.	FREQ. (MHz)	EMISSION LEVEL (dBuV/m)	LIMIT (dBuV/m)	MARGIN (dB)	ANTENNA HEIGHT (m)	TABLE ANGLE (Degree)	RAW VALUE (dBuV)	CORRECTION FACTOR (dB/m)
1	125.01	28.50 QP	43.50	-15.00	1.00 V	9	15.27	13.23
2	250.01	24.06 QP	46.00	-21.94	1.00 V	1	11.23	12.83
3	375.01	26.26 QP	46.00	-19.74	1.00 V	260	8.78	17.48
4	500.01	23.82 QP	46.00	-22.18	1.00 V	43	2.77	21.05
5	600.00	23.01 QP	46.00	-22.99	1.00 V	137	-0.53	23.54
6	750.00	26.93 QP	46.00	-19.07	1.08 V	346	-0.33	27.26
7	800.00	31.54 QP	46.00	-14.46	1.00 V	223	3.49	28.05
8	875.00	26.85 QP	46.00	-19.15	1.00 V	281	-2.22	29.07

- REMARKS:**
1. Emission level (dBuV/m) = Raw Value (dBuV) + Correction Factor (dB/m).
 2. Correction Factor (dB/m) = Antenna Factor (dB/m) + Cable Factor (dB).
 3. The other emission levels were very low against the limit.
 4. Margin value = Emission level – Limit value.

802.11b DSSS MODULATION

EUT TEST CONDITION		MEASUREMENT DETAIL	
CHANNEL	Channel 1	FREQUENCY RANGE	1 ~ 25GHz
INPUT POWER (SYSTEM)	120Vac, 60 Hz	DETECTOR FUNCTION	Peak (PK) Average (AV)
ENVIRONMENTAL CONDITIONS	24deg. C, 74%RH 972hPa	TESTED BY	Sky Liao

ANTENNA POLARITY & TEST DISTANCE: HORIZONTAL AT 3 M								
NO.	FREQ. (MHz)	EMISSION LEVEL (dBuV/m)	LIMIT (dBuV/m)	MARGIN (dB)	ANTENNA HEIGHT (m)	TABLE ANGLE (Degree)	RAW VALUE (dBuV)	CORRECTION FACTOR (dB/m)
1	2383.60	55.36 PK	74.00	-18.64	1.98 H	344	24.99	30.37
2	2383.60	43.81 AV	54.00	-10.19	1.98 H	344	13.44	30.37
3	*2412.00	96.20 PK			1.98 H	344	65.71	30.49
4	*2412.00	90.30 AV			1.98 H	344	59.81	30.49
5	4824.00	55.90 PK	74.00	-18.10	1.44 H	255	20.21	35.69
6	4824.00	52.90 AV	54.00	-1.10	1.44 H	255	17.21	35.69
7	7236.00	55.00 PK	76.20	-21.20	1.38 H	266	12.76	42.24
8	7236.00	44.50 AV	70.30	-25.80	1.38 H	266	2.26	42.24
ANTENNA POLARITY & TEST DISTANCE: VERTICAL AT 3 M								
NO.	FREQ. (MHz)	EMISSION LEVEL (dBuV/m)	LIMIT (dBuV/m)	MARGIN (dB)	ANTENNA HEIGHT (m)	TABLE ANGLE (Degree)	RAW VALUE (dBuV)	CORRECTION FACTOR (dB/m)
1	2378.48	59.22 PK	74.00	-14.78	1.00 V	1	28.88	30.34
2	2378.48	47.31 AV	54.00	-6.69	1.00 V	1	16.97	30.34
3	*2412.00	103.90 PK			1.00 V	3	73.41	30.49
4	*2412.00	99.20 AV			1.00 V	3	68.71	30.49
5	4824.00	56.00 PK	74.00	-18.00	1.20 V	295	20.31	35.69
6	4824.00	53.00 AV	54.00	-1.00	1.20 V	295	17.31	35.69
7	7236.00	54.30 PK	83.90	-29.60	1.26 V	170	12.06	42.24
8	7236.00	42.20 AV	79.20	-37.00	1.26 V	170	-0.04	42.24

- REMARKS:**
1. Emission level (dBuV/m) = Raw Value (dBuV) + Correction Factor (dB/m).
 2. Correction Factor (dB/m) = Antenna Factor (dB/m) + Cable Factor (dB).
 3. The other emission levels were very low against the limit.
 4. Margin value = Emission level – Limit value.
 5. “ * “: Fundamental frequency.

EUT TEST CONDITION		MEASUREMENT DETAIL	
CHANNEL	Channel 6	FREQUENCY RANGE	1 ~ 25GHz
INPUT POWER (SYSTEM)	120Vac, 60 Hz	DETECTOR FUNCTION	Peak (PK) Average (AV)
ENVIRONMENTAL CONDITIONS	24deg. C, 74%RH 972hPa	TESTED BY	Sky Liao

ANTENNA POLARITY & TEST DISTANCE: HORIZONTAL AT 3 M								
NO.	FREQ. (MHz)	EMISSION LEVEL (dBuV/m)	LIMIT (dBuV/m)	MARGIN (dB)	ANTENNA HEIGHT (m)	TABLE ANGLE (Degree)	RAW VALUE (dBuV)	CORRECTION FACTOR (dB/m)
1	*2437.00	95.30 PK			1.55 H	348	64.69	30.61
2	*2437.00	88.20 AV			1.55 H	348	57.59	30.61
3	4874.00	54.50 PK	74.00	-19.50	1.57 H	266	18.70	35.80
4	4874.00	51.90 AV	54.00	-2.10	1.57 H	266	16.10	35.80
5	7311.00	54.20 PK	74.00	-19.80	1.36 H	266	11.68	42.52
6	7311.00	41.80 AV	54.00	-12.20	1.36 H	266	-0.72	42.52
ANTENNA POLARITY & TEST DISTANCE: VERTICAL AT 3 M								
NO.	FREQ. (MHz)	EMISSION LEVEL (dBuV/m)	LIMIT (dBuV/m)	MARGIN (dB)	ANTENNA HEIGHT (m)	TABLE ANGLE (Degree)	RAW VALUE (dBuV)	CORRECTION FACTOR (dB/m)
1	*2437.00	105.00 PK			1.00 V	355	74.39	30.61
2	*2437.00	100.00 AV			1.00 V	355	69.39	30.61
3	4874.00	55.60 PK	74.00	-18.40	1.35 V	288	19.80	35.80
4	4874.00	52.90 AV	54.00	-1.10	1.35 V	288	17.10	35.80
5	7311.00	54.20 PK	74.00	-19.80	1.28 V	175	11.68	42.52
6	7311.00	41.60 AV	54.00	-12.40	1.28 V	175	-0.92	42.52

- REMARKS:**
1. Emission level (dBuV/m) = Raw Value (dBuV) + Correction Factor (dB/m).
 2. Correction Factor (dB/m) = Antenna Factor (dB/m) + Cable Factor (dB).
 3. The other emission levels were very low against the limit.
 4. Margin value = Emission level – Limit value.
 5. “ * “: Fundamental frequency.

EUT TEST CONDITION		MEASUREMENT DETAIL	
CHANNEL	Channel 11	FREQUENCY RANGE	1 ~ 25GHz
INPUT POWER (SYSTEM)	120Vac, 60 Hz	DETECTOR FUNCTION	Peak (PK) Average (AV)
ENVIRONMENTAL CONDITIONS	24deg. C, 74%RH 972hPa	TESTED BY	Sky Liao

ANTENNA POLARITY & TEST DISTANCE: HORIZONTAL AT 3 M								
NO.	FREQ. (MHz)	EMISSION LEVEL (dBuV/m)	LIMIT (dBuV/m)	MARGIN (dB)	ANTENNA HEIGHT (m)	TABLE ANGLE (Degree)	RAW VALUE (dBuV)	CORRECTION FACTOR (dB/m)
1	*2462.00	95.10 PK			1.00 H	346	64.38	30.72
2	*2462.00	88.40 AV			1.00 H	346	57.68	30.72
3	2483.50	56.56 PK	74.00	-17.44	1.55 H	346	25.74	30.82
4	2483.50	43.93 AV	54.00	-10.07	1.55 H	346	13.11	30.82
5	4924.00	53.60 PK	74.00	-20.40	1.55 H	262	17.70	35.90
6	4924.00	50.30 AV	54.00	-3.70	1.55 H	262	14.40	35.90
7	7386.00	54.40 PK	74.00	-19.60	1.35 H	265	11.60	42.80
8	7386.00	41.70 AV	54.00	-12.30	1.35 H	265	-1.10	42.80
ANTENNA POLARITY & TEST DISTANCE: VERTICAL AT 3 M								
NO.	FREQ. (MHz)	EMISSION LEVEL (dBuV/m)	LIMIT (dBuV/m)	MARGIN (dB)	ANTENNA HEIGHT (m)	TABLE ANGLE (Degree)	RAW VALUE (dBuV)	CORRECTION FACTOR (dB/m)
1	*2462.00	104.90 PK			1.20 V	0	74.18	30.72
2	*2462.00	99.80 AV			1.20 V	0	69.08	30.72
3	2495.80	60.68 PK	74.00	-13.32	1.00 V	355	29.81	30.87
4	2495.80	48.36 AV	54.00	-5.64	1.00 V	355	17.49	30.87
5	4924.00	51.10 PK	74.00	-22.90	1.20 V	294	15.20	35.90
6	4924.00	52.60 AV	54.00	-1.40	1.20 V	294	16.70	35.90
7	7386.00	54.00 PK	74.00	-20.00	1.14 V	172	11.20	42.80
8	7386.00	41.40 AV	54.00	-12.60	1.14 V	172	-1.40	42.80

- REMARKS:**
1. Emission level (dBuV/m) = Raw Value (dBuV) + Correction Factor (dB/m).
 2. Correction Factor (dB/m) = Antenna Factor (dB/m) + Cable Factor (dB).
 3. The other emission levels were very low against the limit.
 4. Margin value = Emission level – Limit value.
 5. “ * “: Fundamental frequency.

RESTRICTED BANDEDGE (802.11b MODE, CH1, VERTICAL)

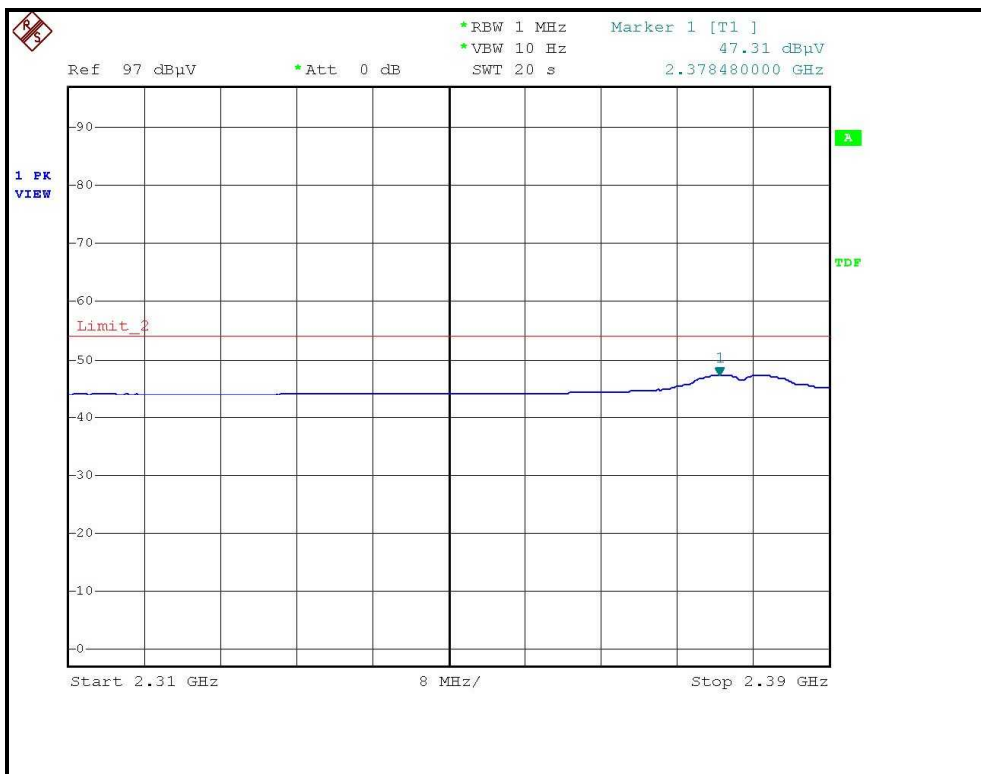
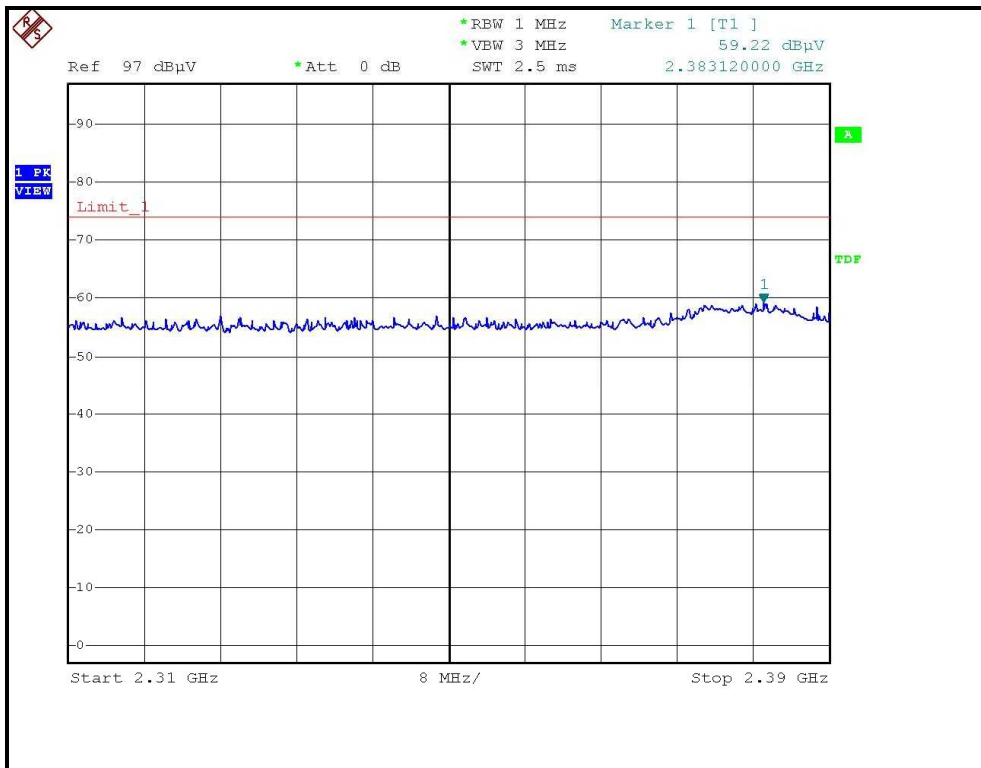

RESTRICTED BANDEDGE (802.11b MODE, CH11, HORIZONTAL)

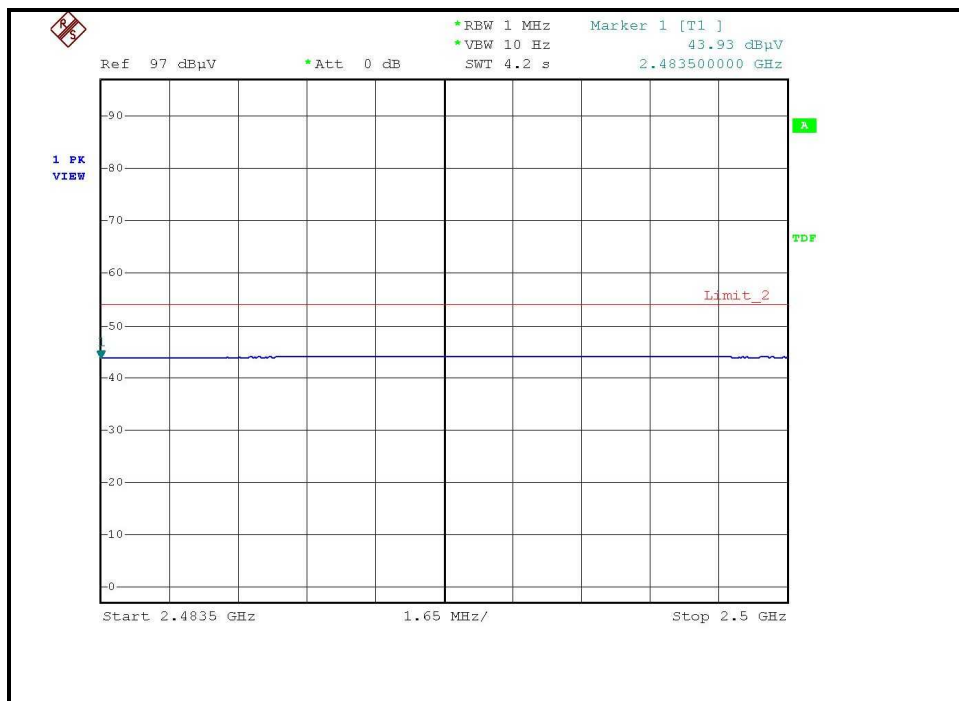
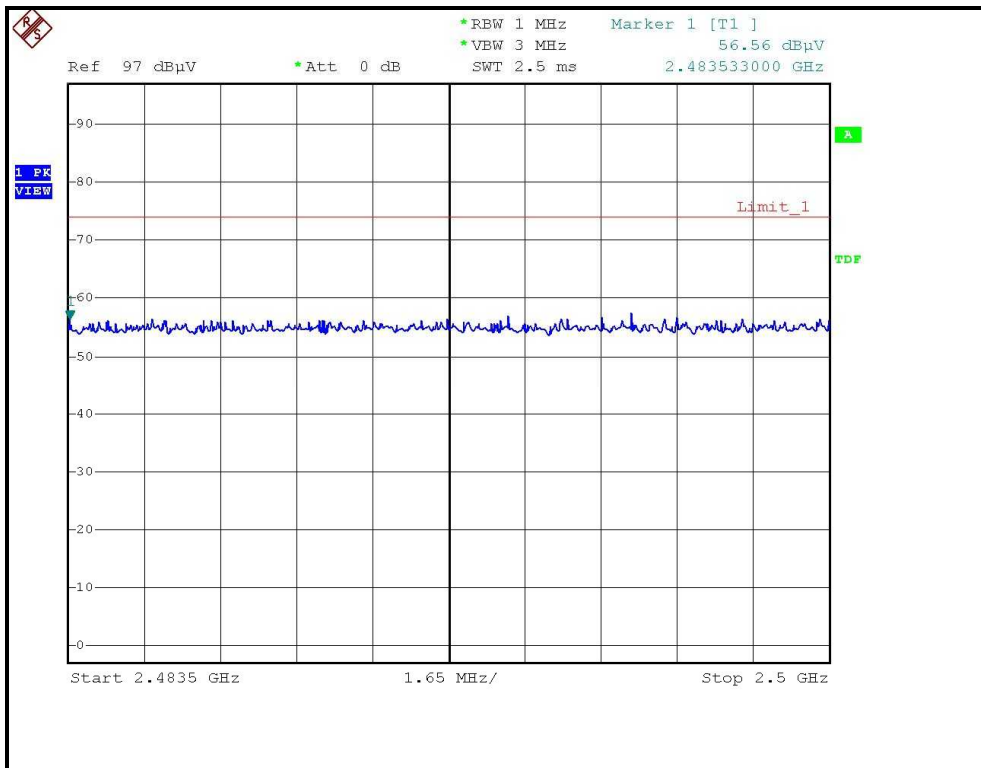

802.11g OFDM MODULATION

EUT TEST CONDITION		MEASUREMENT DETAIL	
CHANNEL	Channel 1	FREQUENCY RANGE	1 ~ 25GHz
INPUT POWER (SYSTEM)	120Vac, 60 Hz	DETECTOR FUNCTION	Peak (PK) Average (AV)
ENVIRONMENTAL CONDITIONS	24deg. C, 74%RH 972hPa	TESTED BY	Sky Liao

ANTENNA POLARITY & TEST DISTANCE: HORIZONTAL AT 3 M								
NO.	FREQ. (MHz)	EMISSION LEVEL (dBuV/m)	LIMIT (dBuV/m)	MARGIN (dB)	ANTENNA HEIGHT (m)	TABLE ANGLE (Degree)	RAW VALUE (dBuV)	CORRECTION FACTOR (dB/m)
1	2390.00	57.31 PK	74.00	-16.69	1.54 H	328	26.91	30.40
2	2390.00	44.80 AV	54.00	-9.20	1.54 H	328	14.40	30.40
3	*2412.00	96.80 PK			1.54 H	328	66.31	30.49
4	*2412.00	86.20 AV			1.54 H	328	55.71	30.49
5	4824.00	59.80 PK	74.00	-14.20	1.68 H	280	24.11	35.69
6	4824.00	45.60 AV	54.00	-8.40	1.68 H	280	9.91	35.69
7	7236.00	59.60 PK	76.80	-17.20	1.40 H	276	17.36	42.24
8	7236.00	44.40 AV	66.20	-21.80	1.40 H	276	2.16	42.24
ANTENNA POLARITY & TEST DISTANCE: VERTICAL AT 3 M								
NO.	FREQ. (MHz)	EMISSION LEVEL (dBuV/m)	LIMIT (dBuV/m)	MARGIN (dB)	ANTENNA HEIGHT (m)	TABLE ANGLE (Degree)	RAW VALUE (dBuV)	CORRECTION FACTOR (dB/m)
1	2390.00	67.85 PK	74.00	-6.15	1.00 V	20	37.45	30.40
2	2390.00	52.30 AV	54.00	-1.70	1.00 V	20	21.90	30.40
3	*2412.00	107.40 PK			1.17 V	330	76.91	30.49
4	*2412.00	96.80 AV			1.17 V	330	66.31	30.49
5	4824.00	56.40 PK	74.00	-17.60	1.44 V	16	20.71	35.69
6	4824.00	42.20 AV	54.00	-11.80	1.44 V	16	6.51	35.69
7	7236.00	58.60 PK	87.40	-28.80	1.18 V	302	16.36	42.24
8	7236.00	46.00 AV	76.80	-30.80	1.18 V	302	3.76	42.24

- REMARKS:**
1. Emission level (dBuV/m) = Raw Value (dBuV) + Correction Factor (dB/m).
 2. Correction Factor (dB/m) = Antenna Factor (dB/m) + Cable Factor (dB).
 3. The other emission levels were very low against the limit.
 4. Margin value = Emission level – Limit value.
 5. “ * “: Fundamental frequency.

EUT TEST CONDITION		MEASUREMENT DETAIL	
CHANNEL	Channel 6	FREQUENCY RANGE	1 ~ 25GHz
INPUT POWER (SYSTEM)	120Vac, 60 Hz	DETECTOR FUNCTION	Peak (PK) Average (AV)
ENVIRONMENTAL CONDITIONS	24deg. C, 74%RH 972hPa	TESTED BY	Sky Liao

ANTENNA POLARITY & TEST DISTANCE: HORIZONTAL AT 3 M								
NO.	FREQ. (MHz)	EMISSION LEVEL (dBuV/m)	LIMIT (dBuV/m)	MARGIN (dB)	ANTENNA HEIGHT (m)	TABLE ANGLE (Degree)	RAW VALUE (dBuV)	CORRECTION FACTOR (dB/m)
1	*2437.00	100.50 PK			1.55 H	348	69.89	30.61
2	*2437.00	89.40 AV			1.55 H	348	58.79	30.61
3	4874.00	60.20 PK	74.00	-13.80	1.65 H	274	24.40	35.80
4	4874.00	46.00 AV	54.00	-8.00	1.65 H	274	10.20	35.80
5	7311.00	59.90 PK	74.00	-14.10	1.44 H	266	17.38	42.52
6	7311.00	45.00 AV	54.00	-9.00	1.44 H	266	2.48	42.52
ANTENNA POLARITY & TEST DISTANCE: VERTICAL AT 3 M								
NO.	FREQ. (MHz)	EMISSION LEVEL (dBuV/m)	LIMIT (dBuV/m)	MARGIN (dB)	ANTENNA HEIGHT (m)	TABLE ANGLE (Degree)	RAW VALUE (dBuV)	CORRECTION FACTOR (dB/m)
1	*2437.00	108.50 PK			1.18 V	330	77.89	30.61
2	*2437.00	98.20 AV			1.18 V	330	67.59	30.61
3	4874.00	57.00 PK	74.00	-17.00	1.40 V	7	21.20	35.80
4	4874.00	42.60 AV	54.00	-11.40	1.40 V	7	6.80	35.80
5	7311.00	60.50 PK	74.00	-13.50	1.14 V	296	17.98	42.52
6	7311.00	46.60 AV	54.00	-7.40	1.14 V	296	4.08	42.52

- REMARKS:**
1. Emission level (dBuV/m) = Raw Value (dBuV) + Correction Factor (dB/m).
 2. Correction Factor (dB/m) = Antenna Factor (dB/m) + Cable Factor (dB).
 3. The other emission levels were very low against the limit.
 4. Margin value = Emission level – Limit value.
 5. “ * “: Fundamental frequency.

EUT TEST CONDITION		MEASUREMENT DETAIL	
CHANNEL	Channel 11	FREQUENCY RANGE	1 ~ 25GHz
INPUT POWER (SYSTEM)	120Vac, 60 Hz	DETECTOR FUNCTION	Peak (PK) Average (AV)
ENVIRONMENTAL CONDITIONS	24deg. C, 74%RH 972hPa	TESTED BY	Sky Liao

ANTENNA POLARITY & TEST DISTANCE: HORIZONTAL AT 3 M								
NO.	FREQ. (MHz)	EMISSION LEVEL (dBuV/m)	LIMIT (dBuV/m)	MARGIN (dB)	ANTENNA HEIGHT (m)	TABLE ANGLE (Degree)	RAW VALUE (dBuV)	CORRECTION FACTOR (dB/m)
1	*2462.00	97.20 PK			1.56 H	344	66.48	30.72
2	*2462.00	86.50 AV			1.56 H	344	55.78	30.72
3	2483.50	57.94 PK	74.00	-16.06	1.56 H	344	27.12	30.82
4	2483.50	44.96 AV	54.00	-9.04	1.56 H	344	14.14	30.82
5	4924.00	59.60 PK	74.00	-14.40	1.62 H	277	23.70	35.90
6	4924.00	45.60 AV	54.00	-8.40	1.62 H	277	9.70	35.90
7	7386.00	59.80 PK	74.00	-14.20	1.14 H	264	17.00	42.80
8	7386.00	44.20 AV	54.00	-9.80	1.14 H	264	1.40	42.80
ANTENNA POLARITY & TEST DISTANCE: VERTICAL AT 3 M								
NO.	FREQ. (MHz)	EMISSION LEVEL (dBuV/m)	LIMIT (dBuV/m)	MARGIN (dB)	ANTENNA HEIGHT (m)	TABLE ANGLE (Degree)	RAW VALUE (dBuV)	CORRECTION FACTOR (dB/m)
1	*2462.00	107.70 PK			1.17 V	330	76.98	30.72
2	*2462.00	97.60 AV			1.17 V	330	66.88	30.72
3	2483.50	66.06 PK	74.00	-7.94	1.00 V	1	35.24	30.82
4	2483.50	51.15 AV	54.00	-2.85	1.00 V	1	20.33	30.82
5	4924.00	56.60 PK	74.00	-17.40	1.48 V	10	20.70	35.90
6	4924.00	42.40 AV	54.00	-11.60	1.48 V	10	6.50	35.90
7	7386.00	60.00 PK	74.00	-14.00	1.20 V	288	17.20	42.80
8	7386.00	46.20 AV	54.00	-7.80	1.20 V	288	3.40	42.80

- REMARKS:**
1. Emission level (dBuV/m) = Raw Value (dBuV) + Correction Factor (dB/m).
 2. Correction Factor (dB/m) = Antenna Factor (dB/m) + Cable Factor (dB).
 3. The other emission levels were very low against the limit.
 4. Margin value = Emission level – Limit value.
 5. “ * “: Fundamental frequency.

DRAFT 802.11n (20MHz) OFDM MODULATION

EUT TEST CONDITION		MEASUREMENT DETAIL	
CHANNEL	Channel 1	FREQUENCY RANGE	1 ~ 25GHz
INPUT POWER (SYSTEM)	120Vac, 60 Hz	DETECTOR FUNCTION	Peak (PK) Average (AV)
ENVIRONMENTAL CONDITIONS	24deg. C, 74%RH 972hPa	TESTED BY	Sky Liao

ANTENNA POLARITY & TEST DISTANCE: HORIZONTAL AT 3 M								
NO.	FREQ. (MHz)	EMISSION LEVEL (dBuV/m)	LIMIT (dBuV/m)	MARGIN (dB)	ANTENNA HEIGHT (m)	TABLE ANGLE (Degree)	RAW VALUE (dBuV)	CORRECTION FACTOR (dB/m)
1	2390.00	58.28 PK	74.00	-15.72	2.10 H	36	27.88	30.40
2	2390.00	45.43 AV	54.00	-8.57	2.10 H	36	15.03	30.40
3	*2412.00	101.00 PK			2.00 H	344	70.51	30.49
4	*2412.00	89.50 AV			2.00 H	344	59.01	30.49
5	4824.00	58.20 PK	74.00	-15.80	1.55 H	260	22.51	35.69
6	4824.00	44.60 AV	54.00	-9.40	1.55 H	260	8.91	35.69
7	7236.00	56.80 PK	81.00	-24.20	1.42 H	278	14.56	42.24
8	7236.00	42.60 AV	69.50	-26.90	1.42 H	278	0.36	42.24
ANTENNA POLARITY & TEST DISTANCE: VERTICAL AT 3 M								
NO.	FREQ. (MHz)	EMISSION LEVEL (dBuV/m)	LIMIT (dBuV/m)	MARGIN (dB)	ANTENNA HEIGHT (m)	TABLE ANGLE (Degree)	RAW VALUE (dBuV)	CORRECTION FACTOR (dB/m)
1	2390.00	68.70 PK	74.00	-5.30	1.03 V	22	38.30	30.40
2	2390.00	53.23 AV	54.00	-0.77	1.03 V	22	22.83	30.40
3	*2412.00	110.80 PK			1.03 V	22	80.31	30.49
4	*2412.00	99.30 AV			1.03 V	22	68.81	30.49
5	4824.00	57.40 PK	74.00	-16.60	1.32 V	290	21.71	35.69
6	4824.00	43.70 AV	54.00	-10.30	1.32 V	290	8.01	35.69
7	7236.00	56.00 PK	90.80	-34.80	1.40 V	60	13.76	42.24
8	7236.00	42.00 AV	79.30	-37.30	1.40 V	60	-0.24	42.24

- REMARKS:**
1. Emission level (dBuV/m) = Raw Value (dBuV) + Correction Factor (dB/m).
 2. Correction Factor (dB/m) = Antenna Factor (dB/m) + Cable Factor (dB).
 3. The other emission levels were very low against the limit.
 4. Margin value = Emission level – Limit value.
 5. “ * “: Fundamental frequency.

EUT TEST CONDITION		MEASUREMENT DETAIL	
CHANNEL	Channel 6	FREQUENCY RANGE	1 ~ 25GHz
INPUT POWER (SYSTEM)	120Vac, 60 Hz	DETECTOR FUNCTION	Peak (PK) Average (AV)
ENVIRONMENTAL CONDITIONS	24deg. C, 74%RH 972hPa	TESTED BY	Sky Liao

ANTENNA POLARITY & TEST DISTANCE: HORIZONTAL AT 3 M								
NO.	FREQ. (MHz)	EMISSION LEVEL (dBuV/m)	LIMIT (dBuV/m)	MARGIN (dB)	ANTENNA HEIGHT (m)	TABLE ANGLE (Degree)	RAW VALUE (dBuV)	CORRECTION FACTOR (dB/m)
1	*2437.00	101.50 PK			2.00 H	38	70.89	30.61
2	*2437.00	89.20 AV			2.00 H	38	58.59	30.61
3	4874.00	60.30 PK	74.00	-13.70	1.58 H	266	24.50	35.80
4	4874.00	47.00 AV	54.00	-7.00	1.58 H	266	11.20	35.80
5	7311.00	59.60 PK	74.00	-14.40	1.44 H	266	17.08	42.52
6	7311.00	46.20 AV	54.00	-7.80	1.44 H	266	3.68	42.52
ANTENNA POLARITY & TEST DISTANCE: VERTICAL AT 3 M								
NO.	FREQ. (MHz)	EMISSION LEVEL (dBuV/m)	LIMIT (dBuV/m)	MARGIN (dB)	ANTENNA HEIGHT (m)	TABLE ANGLE (Degree)	RAW VALUE (dBuV)	CORRECTION FACTOR (dB/m)
1	*2437.00	113.50 PK			1.00 V	12	82.89	30.61
2	*2437.00	101.90 AV			1.00 V	12	71.29	30.61
3	4874.00	59.80 PK	74.00	-14.20	1.30 V	340	24.00	35.80
4	4874.00	46.40 AV	54.00	-7.60	1.30 V	340	10.60	35.80
5	7311.00	59.00 PK	74.00	-15.00	1.55 V	60	16.48	42.52
6	7311.00	45.20 AV	54.00	-8.80	1.55 V	60	2.68	42.52

- REMARKS:**
1. Emission level (dBuV/m) = Raw Value (dBuV) + Correction Factor (dB/m).
 2. Correction Factor (dB/m) = Antenna Factor (dB/m) + Cable Factor (dB).
 3. The other emission levels were very low against the limit.
 4. Margin value = Emission level – Limit value.
 5. “ * “: Fundamental frequency.

EUT TEST CONDITION		MEASUREMENT DETAIL	
CHANNEL	Channel 11	FREQUENCY RANGE	1 ~ 25GHz
INPUT POWER (SYSTEM)	120Vac, 60 Hz	DETECTOR FUNCTION	Peak (PK) Average (AV)
ENVIRONMENTAL CONDITIONS	24deg. C, 74%RH 972hPa	TESTED BY	Sky Liao

ANTENNA POLARITY & TEST DISTANCE: HORIZONTAL AT 3 M								
NO.	FREQ. (MHz)	EMISSION LEVEL (dBuV/m)	LIMIT (dBuV/m)	MARGIN (dB)	ANTENNA HEIGHT (m)	TABLE ANGLE (Degree)	RAW VALUE (dBuV)	CORRECTION FACTOR (dB/m)
1	*2462.00	99.20 PK			2.05 H	30	68.48	30.72
2	*2462.00	88.00 AV			2.05 H	30	57.28	30.72
3	2483.50	66.87 PK	74.00	-7.13	1.90 H	36	36.05	30.82
4	2483.50	47.65 AV	54.00	-6.35	1.90 H	36	16.83	30.82
5	4924.00	59.60 PK	74.00	-14.40	1.52 H	268	23.70	35.90
6	4924.00	46.40 AV	54.00	-7.60	1.52 H	268	10.50	35.90
7	7386.00	59.20 PK	74.00	-14.80	1.48 H	272	16.40	42.80
8	7386.00	45.60 AV	54.00	-8.40	1.48 H	272	2.80	42.80
ANTENNA POLARITY & TEST DISTANCE: VERTICAL AT 3 M								
NO.	FREQ. (MHz)	EMISSION LEVEL (dBuV/m)	LIMIT (dBuV/m)	MARGIN (dB)	ANTENNA HEIGHT (m)	TABLE ANGLE (Degree)	RAW VALUE (dBuV)	CORRECTION FACTOR (dB/m)
1	*2462.00	110.40 PK			1.25 V	355	79.68	30.72
2	*2462.00	98.90 AV			1.25 V	355	68.18	30.72
3	2483.50	70.00 PK	74.00	-4.00	1.20 V	355	39.18	30.82
4	2483.50	53.50 AV	54.00	-0.50	1.20 V	355	22.68	30.82
5	4924.00	54.20 PK	74.00	-19.80	1.38 V	348	18.30	35.90
6	4924.00	45.80 AV	54.00	-8.20	1.38 V	348	9.90	35.90
7	7386.00	58.20 PK	74.00	-15.80	1.52 V	66	15.40	42.80
8	7386.00	44.80 AV	54.00	-9.20	1.52 V	66	2.00	42.80

- REMARKS:**
1. Emission level (dBuV/m) = Raw Value (dBuV) + Correction Factor (dB/m).
 2. Correction Factor (dB/m) = Antenna Factor (dB/m) + Cable Factor (dB).
 3. The other emission levels were very low against the limit.
 4. Margin value = Emission level – Limit value.
 5. “ * “: Fundamental frequency.

DRAFT 802.11n (40MHz) OFDM MODULATION

EUT TEST CONDITION		MEASUREMENT DETAIL	
CHANNEL	Channel 1	FREQUENCY RANGE	1 ~ 25GHz
INPUT POWER (SYSTEM)	120Vac, 60 Hz	DETECTOR FUNCTION	Peak (PK) Average (AV)
ENVIRONMENTAL CONDITIONS	24deg. C, 74%RH 972hPa	TESTED BY	Sky Liao

ANTENNA POLARITY & TEST DISTANCE: HORIZONTAL AT 3 M								
NO.	FREQ. (MHz)	EMISSION LEVEL (dBuV/m)	LIMIT (dBuV/m)	MARGIN (dB)	ANTENNA HEIGHT (m)	TABLE ANGLE (Degree)	RAW VALUE (dBuV)	CORRECTION FACTOR (dB/m)
1	2389.80	55.88 PK	74.00	-18.12	1.53 H	330	25.49	30.39
2	2389.80	45.07 AV	54.00	-8.93	1.53 H	330	14.68	30.39
3	*2422.00	94.20 PK			1.50 H	262	63.66	30.54
4	*2422.00	82.50 AV			1.50 H	262	51.96	30.54
5	4844.00	50.70 PK	74.00	-23.30	1.55 H	257	14.96	35.74
6	4844.00	37.40 AV	54.00	-16.60	1.55 H	257	1.66	35.74
7	7266.00	52.40 PK	74.00	-21.60	1.58 H	266	10.05	42.35
8	7266.00	39.40 AV	54.00	-14.60	1.58 H	266	-2.95	42.35
ANTENNA POLARITY & TEST DISTANCE: VERTICAL AT 3 M								
NO.	FREQ. (MHz)	EMISSION LEVEL (dBuV/m)	LIMIT (dBuV/m)	MARGIN (dB)	ANTENNA HEIGHT (m)	TABLE ANGLE (Degree)	RAW VALUE (dBuV)	CORRECTION FACTOR (dB/m)
1	2390.00	64.58 PK	74.00	-9.42	1.00 V	22	34.18	30.40
2	2390.00	52.81 AV	54.00	-1.19	1.00 V	22	22.41	30.40
3	*2422.00	104.70 PK			1.00 V	22	74.16	30.54
4	*2422.00	93.25 AV			1.00 V	22	62.71	30.54
5	4844.00	50.20 PK	74.00	-23.80	1.20 V	285	14.46	35.74
6	4844.00	37.00 AV	54.00	-17.00	1.20 V	285	1.26	35.74
7	7266.00	51.80 PK	74.00	-22.20	1.28 V	68	9.45	42.35
8	7266.00	38.80 AV	54.00	-15.20	1.28 V	68	-3.55	42.35

- REMARKS:**
1. Emission level (dBuV/m) = Raw Value (dBuV) + Correction Factor (dB/m).
 2. Correction Factor (dB/m) = Antenna Factor (dB/m) + Cable Factor (dB).
 3. The other emission levels were very low against the limit.
 4. Margin value = Emission level – Limit value.
 5. “ * “: Fundamental frequency.

EUT TEST CONDITION		MEASUREMENT DETAIL	
CHANNEL	Channel 4	FREQUENCY RANGE	1 ~ 25GHz
INPUT POWER (SYSTEM)	120Vac, 60 Hz	DETECTOR FUNCTION	Peak (PK) Average (AV)
ENVIRONMENTAL CONDITIONS	24deg. C, 74%RH 972hPa	TESTED BY	Sky Liao

ANTENNA POLARITY & TEST DISTANCE: HORIZONTAL AT 3 M								
NO.	FREQ. (MHz)	EMISSION LEVEL (dBuV/m)	LIMIT (dBuV/m)	MARGIN (dB)	ANTENNA HEIGHT (m)	TABLE ANGLE (Degree)	RAW VALUE (dBuV)	CORRECTION FACTOR (dB/m)
1	*2437.00	98.00 PK			1.55 H	23	67.39	30.61
2	*2437.00	85.90 AV			1.55 H	23	55.29	30.61
3	4874.00	55.30 PK	74.00	-18.70	1.37 H	157	19.50	35.80
4	4874.00	41.20 AV	54.00	-12.80	1.37 H	157	5.40	35.80
5	7311.00	55.60 PK	74.00	-18.40	1.38 H	266	13.08	42.52
6	7311.00	42.20 AV	54.00	-11.80	1.38 H	266	-0.32	42.52
ANTENNA POLARITY & TEST DISTANCE: VERTICAL AT 3 M								
NO.	FREQ. (MHz)	EMISSION LEVEL (dBuV/m)	LIMIT (dBuV/m)	MARGIN (dB)	ANTENNA HEIGHT (m)	TABLE ANGLE (Degree)	RAW VALUE (dBuV)	CORRECTION FACTOR (dB/m)
1	*2437.00	107.90 PK			1.00 V	330	77.29	30.61
2	*2437.00	96.30 AV			1.00 V	330	65.69	30.61
3	4874.00	55.00 PK	74.00	-19.00	1.28 V	292	19.20	35.80
4	4874.00	40.60 AV	54.00	-13.40	1.28 V	292	4.80	35.80
5	7311.00	54.80 PK	74.00	-19.20	1.30 V	66	12.28	42.52
6	7311.00	42.00 AV	54.00	-12.00	1.30 V	66	-0.52	42.52

- REMARKS:**
1. Emission level (dBuV/m) = Raw Value (dBuV) + Correction Factor (dB/m).
 2. Correction Factor (dB/m) = Antenna Factor (dB/m) + Cable Factor (dB).
 3. The other emission levels were very low against the limit.
 4. Margin value = Emission level – Limit value.
 5. “ * “: Fundamental frequency.

EUT TEST CONDITION		MEASUREMENT DETAIL	
CHANNEL	Channel 7	FREQUENCY RANGE	1 ~ 25GHz
INPUT POWER (SYSTEM)	120Vac, 60 Hz	DETECTOR FUNCTION	Peak (PK) Average (AV)
ENVIRONMENTAL CONDITIONS	24deg. C, 74%RH 972hPa	TESTED BY	Sky Liao

ANTENNA POLARITY & TEST DISTANCE: HORIZONTAL AT 3 M								
NO.	FREQ. (MHz)	EMISSION LEVEL (dBuV/m)	LIMIT (dBuV/m)	MARGIN (dB)	ANTENNA HEIGHT (m)	TABLE ANGLE (Degree)	RAW VALUE (dBuV)	CORRECTION FACTOR (dB/m)
1	*2452.00	95.80 PK			1.36 H	98	65.13	30.67
2	*2452.00	84.20 AV			1.36 H	98	53.53	30.67
3	2484.30	55.17 PK	74.00	-18.83	1.35 H	81	24.35	30.82
4	2484.30	44.53 AV	54.00	-9.47	1.35 H	81	13.71	30.82
5	4904.00	55.00 PK	74.00	-19.00	1.30 H	144	19.14	35.86
6	4904.00	41.00 AV	54.00	-13.00	1.30 H	144	5.14	35.86
7	7356.00	55.20 PK	74.00	-18.80	1.42 H	277	12.52	42.68
8	7356.00	41.80 AV	54.00	-12.20	1.42 H	277	-0.88	42.68
ANTENNA POLARITY & TEST DISTANCE: VERTICAL AT 3 M								
NO.	FREQ. (MHz)	EMISSION LEVEL (dBuV/m)	LIMIT (dBuV/m)	MARGIN (dB)	ANTENNA HEIGHT (m)	TABLE ANGLE (Degree)	RAW VALUE (dBuV)	CORRECTION FACTOR (dB/m)
1	*2452.00	105.90 PK			1.18 V	353	75.23	30.67
2	*2452.00	94.50 AV			1.18 V	353	63.83	30.67
3	2484.20	68.95 PK	74.00	-5.05	1.18 V	353	38.13	30.82
4	2484.20	52.94 AV	54.00	-1.06	1.18 V	353	22.12	30.82
5	4904.00	54.60 PK	74.00	-19.40	1.26 V	282	18.74	35.86
6	4904.00	40.40 AV	54.00	-13.60	1.26 V	282	4.54	35.86
7	7356.00	54.20 PK	74.00	-19.80	1.36 V	60	11.52	42.68
8	7356.00	41.60 AV	54.00	-12.40	1.36 V	60	-1.08	42.68

- REMARKS:**
1. Emission level (dBuV/m) = Raw Value (dBuV) + Correction Factor (dB/m).
 2. Correction Factor (dB/m) = Antenna Factor (dB/m) + Cable Factor (dB).
 3. The other emission levels were very low against the limit.
 4. Margin value = Emission level – Limit value.
 5. “ * “: Fundamental frequency.

RESTRICTED BANDEDGE (DRAFT 802.11n (40MHz) MODE, CH1, VERTICAL)

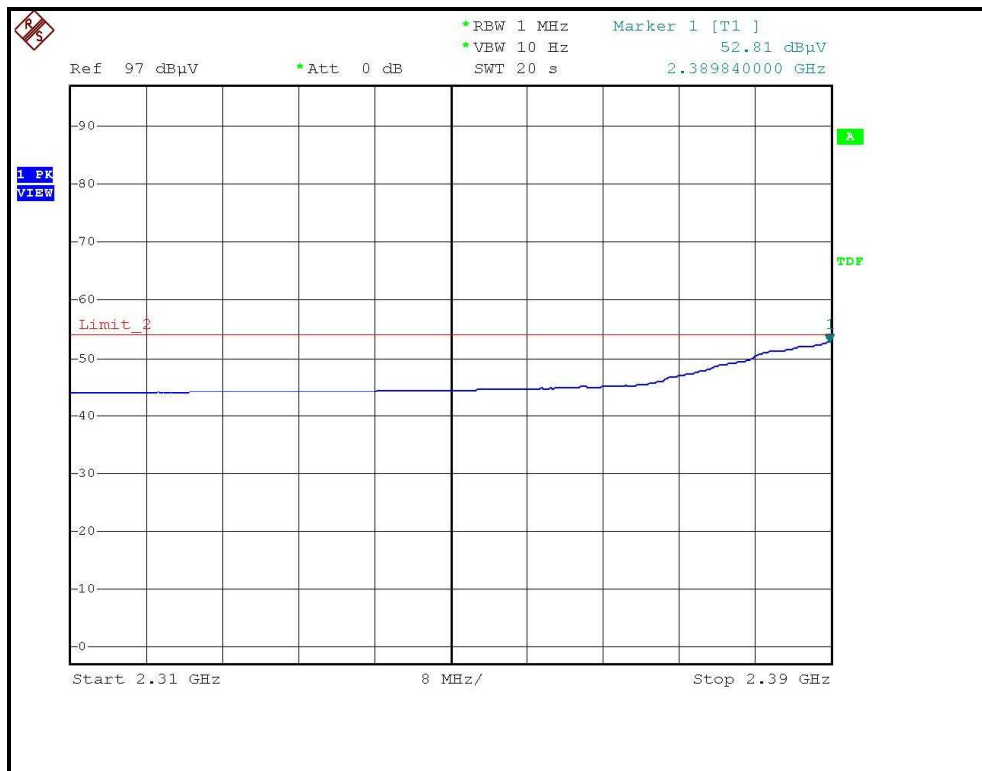
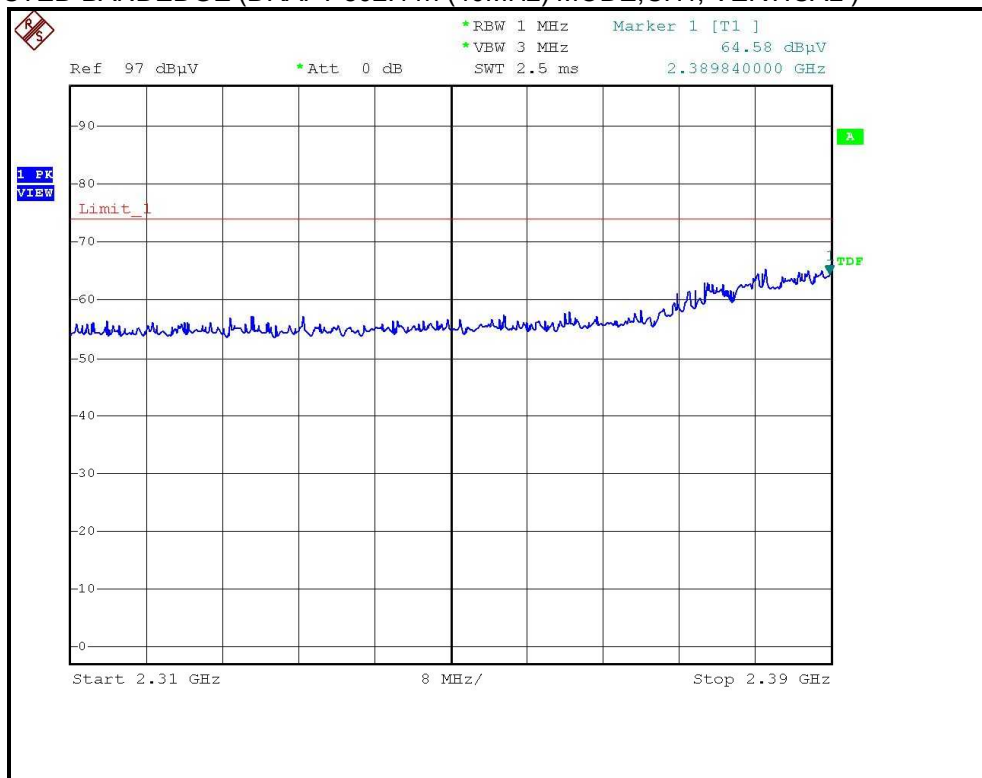



4.3 6dB BANDWIDTH MEASUREMENT

4.3.1 LIMITS OF 6dB BANDWIDTH MEASUREMENT

The minimum of 6dB Bandwidth Measurement is 0.5 MHz.

4.3.2 TEST INSTRUMENTS

Description & Manufacturer	Model No.	Serial No.	Calibrated Until
R&S SPECTRUM ANALYZER	FSP40	100037	Aug. 12, 2008

NOTE:

- 1.The measurement uncertainty is less than +/- 2.6dB, which is calculated as per the NAMAS document NIS81. This uncertainty represents an expanded uncertainty expressed at approximately the 95% confidence level using a coverage factor of k=2.
- 2.The calibration interval of the above test instruments is 12 months and the calibrations are traceable to NML/ROC and NIST/USA.

4.3.3 TEST PROCEDURE

The transmitter output was connected to the spectrum analyzer through an attenuator. The bandwidth of the fundamental frequency was measured by spectrum analyzer with 100kHz RBW and 100kHz VBW. The 6dB bandwidth is defined as the total spectrum the power of which is higher than peak power minus 6dB.

4.3.4 DEVIATION FROM TEST STANDARD

No deviation

4.3.5 TEST SETUP

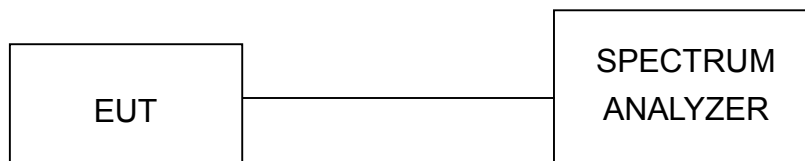

4.3.6 EUT OPERATING CONDITIONS

The software provided by client to enable the EUT under transmission condition continuously at lowest, middle and highest channel frequencies individually.

4.3.7 TEST RESULTS

802.11b DSSS MODULATION:

MODULATION TYPE	CCK	TRANSFER RATE	11Mbps
INPUT POWER	120Vac, 60 Hz	ENVIRONMENTAL CONDITIONS	19deg.C, 69%RH, 972hPa
TESTED BY	Phoenix Huang		

CHANNEL	CHANNEL FREQUENCY (MHz)	6dB BANDWIDTH (MHz)	MINIMUM LIMIT (MHz)	PASS / FAIL
1	2412	12.19	0.5	PASS
6	2437	12.20	0.5	PASS
11	2462	12.19	0.5	PASS

CH1

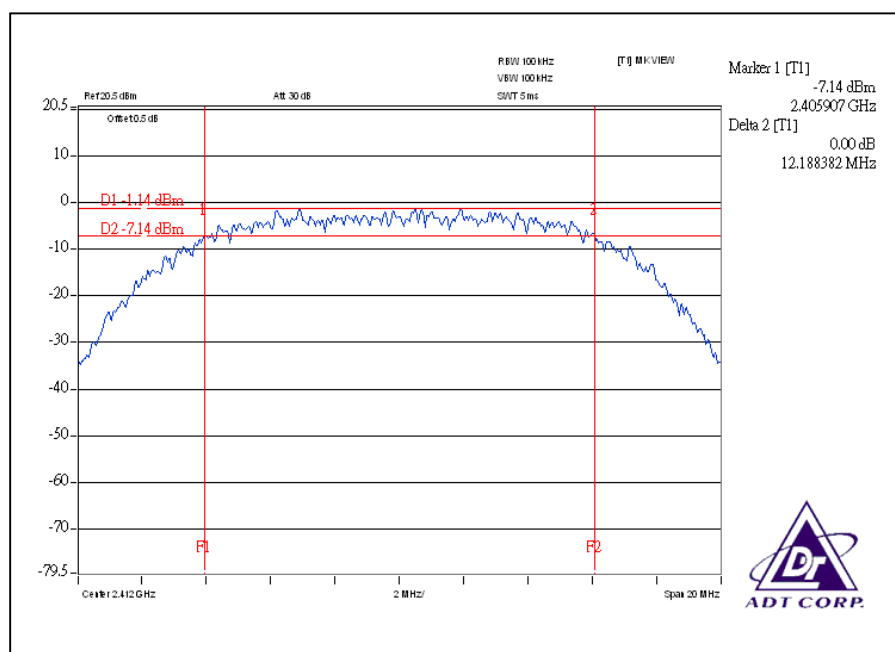

CH6

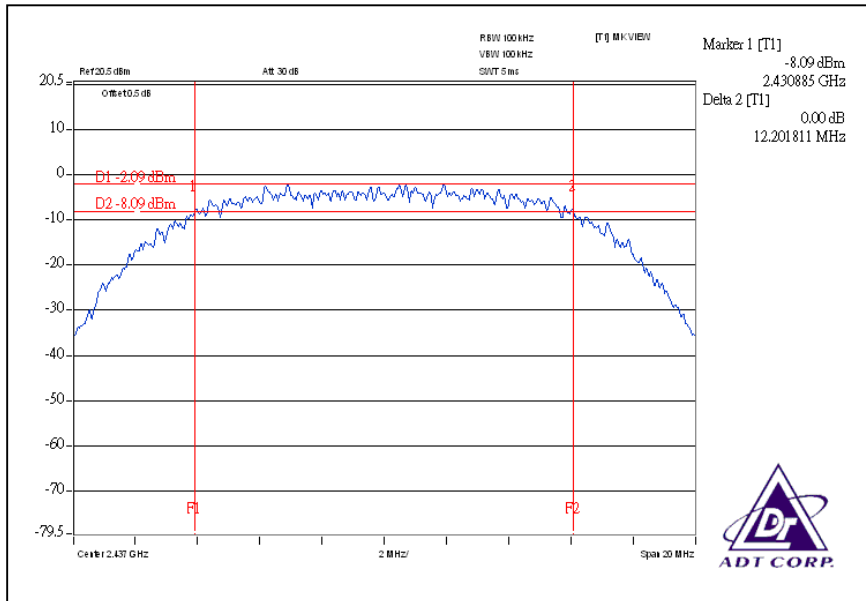

CH11

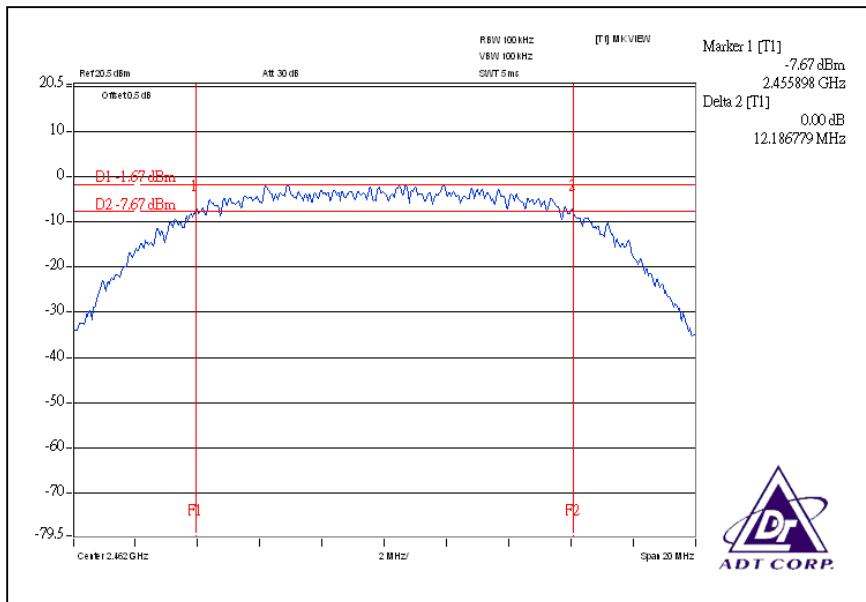

802.11g OFDM MODULATION:

MODULATION TYPE	BPSK	TRANSFER RATE	6Mbps
INPUT POWER	120Vac, 60 Hz	ENVIRONMENTAL CONDITIONS	19deg.C, 69%RH, 972hPa
TESTED BY	Phoenix Huang		

CHANNEL	CHANNEL FREQUENCY (MHz)	6dB BANDWIDTH (MHz)	MINIMUM LIMIT (MHz)	PASS / FAIL
1	2412	16.62	0.5	PASS
6	2437	16.61	0.5	PASS
11	2462	16.62	0.5	PASS

CH1

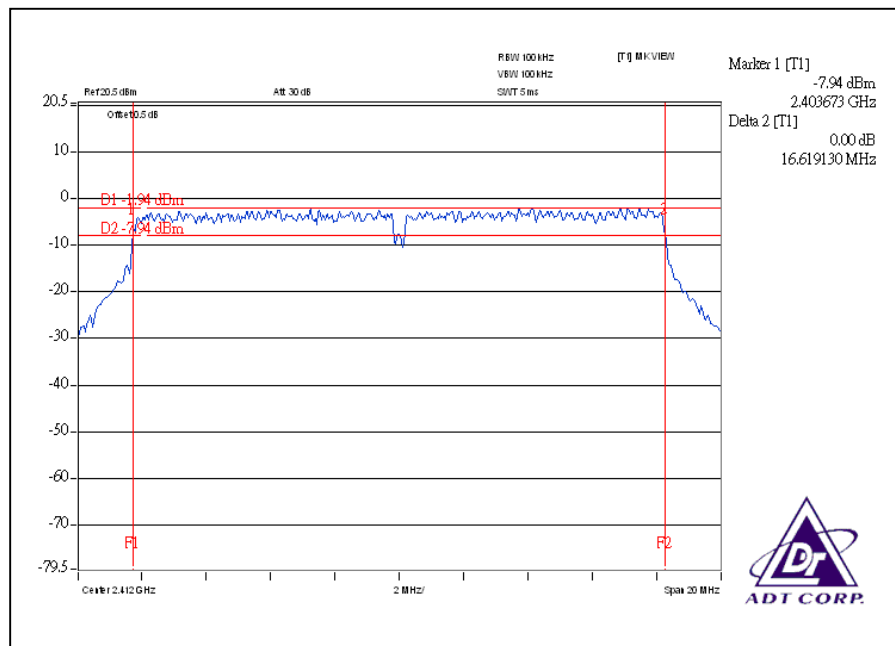

CH6

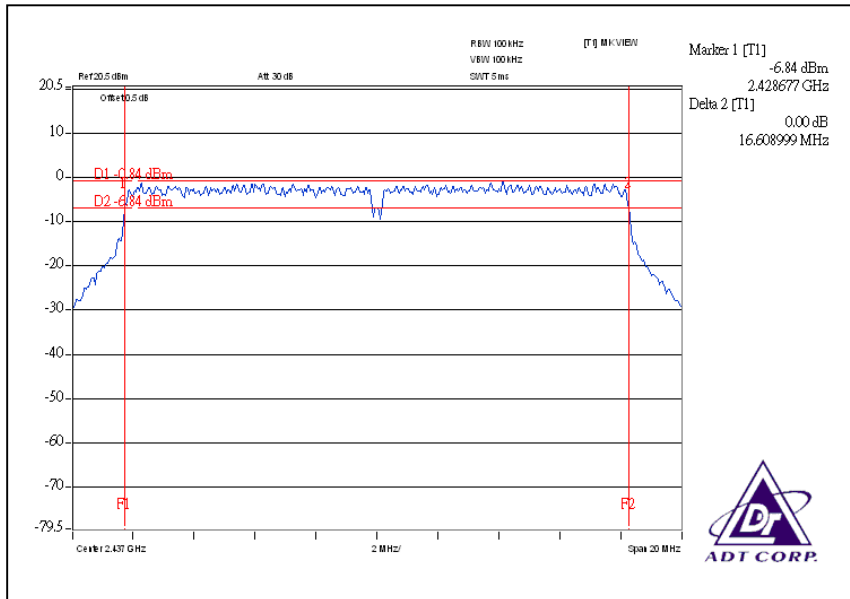

CH11

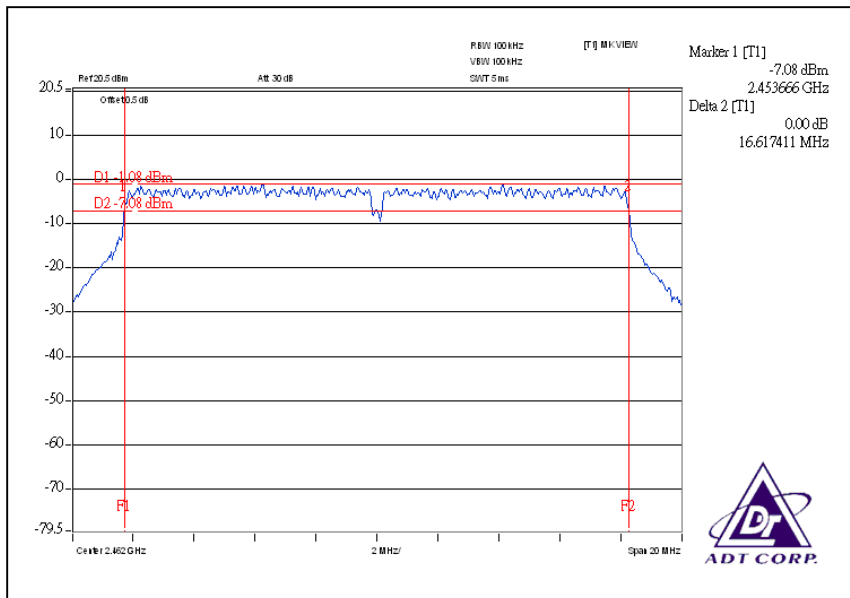

DRAFT 802.11n (20MHz) OFDM MODULATION:

MODULATION TYPE	BPSK	TRANSFER RATE	14.4Mbps
INPUT POWER	120Vac, 60 Hz	ENVIRONMENTAL CONDITIONS	23deg.C, 54%RH, 972hPa
TESTED BY	Phoenix Huang		

CHANNEL	CHANNEL FREQUENCY (MHz)	6dB BANDWIDTH (MHz)		MINIMUM LIMIT (MHz)	PASS / FAIL
		CHAIN(0)	CHAIN(1)		
1	2412	17.78	17.70	0.5	PASS
6	2437	17.78	17.70	0.5	PASS
11	2462	17.78	17.70	0.5	PASS

For Chain(0): CH1

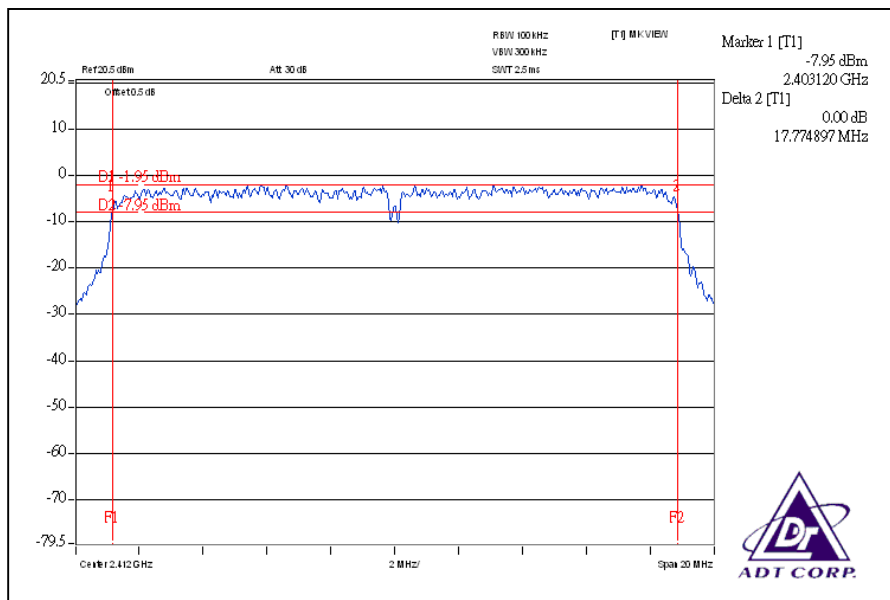

CH6

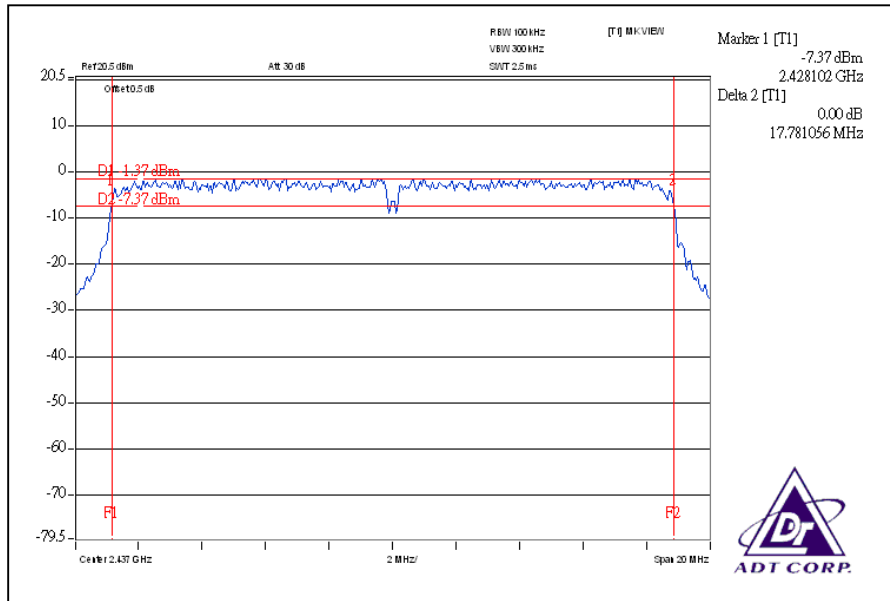

CH11

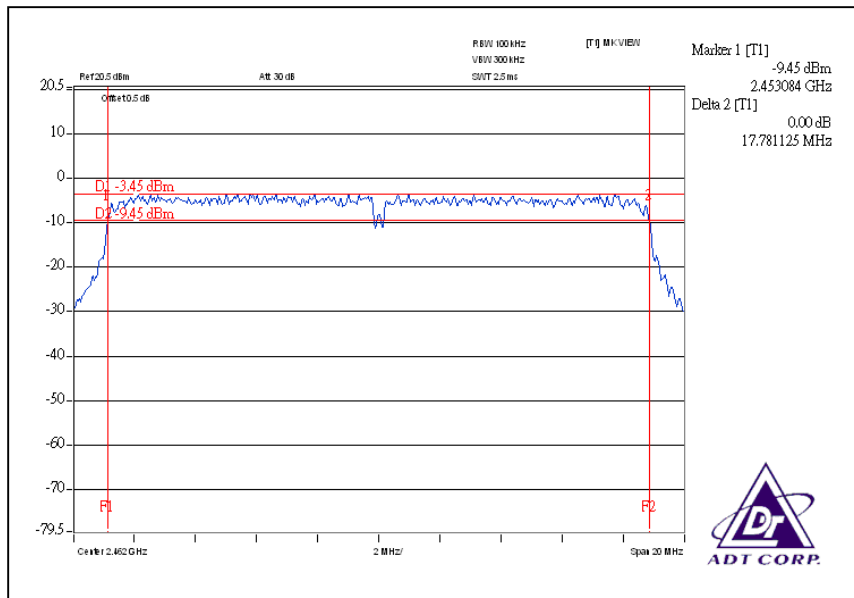

For CHAIN(1): CH1

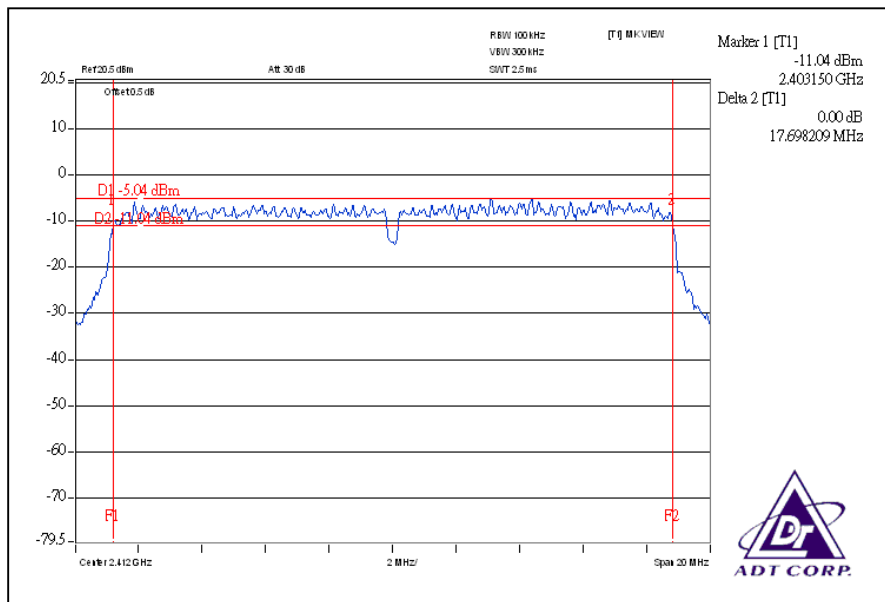

CH6

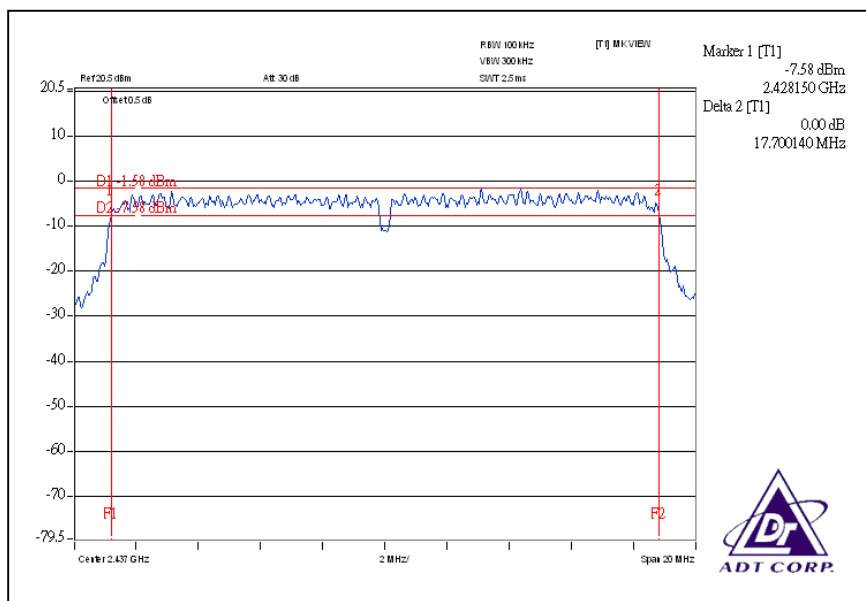

DRAFT 802.11n (40MHz) OFDM MODULATION:

MODULATION TYPE	BPSK	TRANSFER RATE	30Mbps
INPUT POWER	120Vac, 60 Hz	ENVIRONMENTAL CONDITIONS	23deg.C, 54%RH, 972hPa
TESTED BY	Phoenix Huang		

CHANNEL	CHANNEL FREQUENCY (MHz)	6dB BANDWIDTH (MHz)		MINIMUM LIMIT (MHz)	PASS / FAIL
		CHAIN(0)	CHAIN(1)		
1	2422	36.48	36.46	0.5	PASS
4	2437	36.47	36.46	0.5	PASS
7	2452	36.49	36.50	0.5	PASS

For Chain (0): CH1

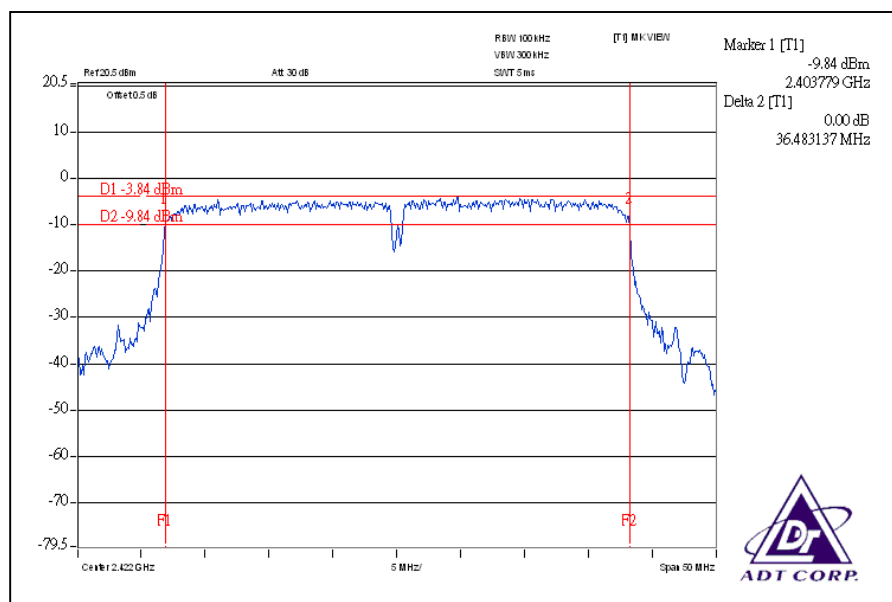

CH4

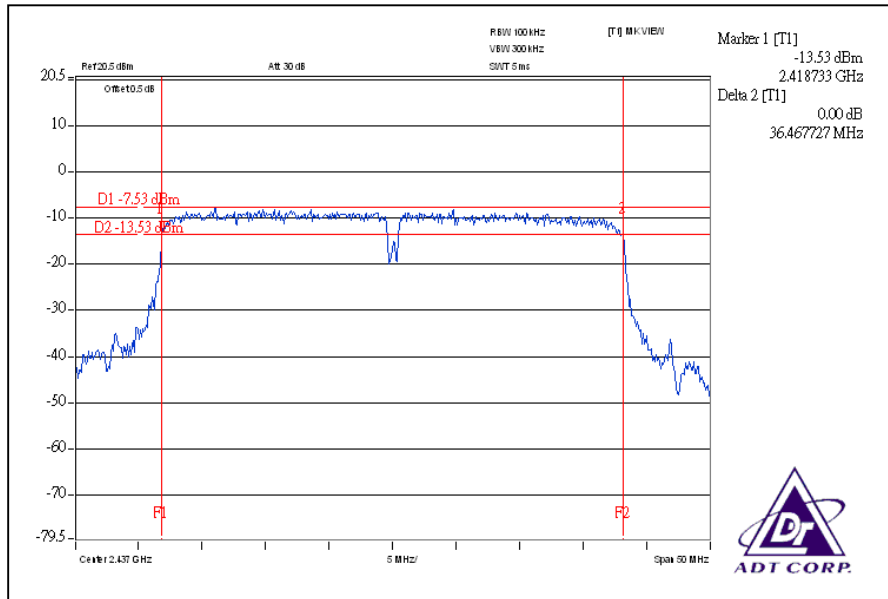

CH7

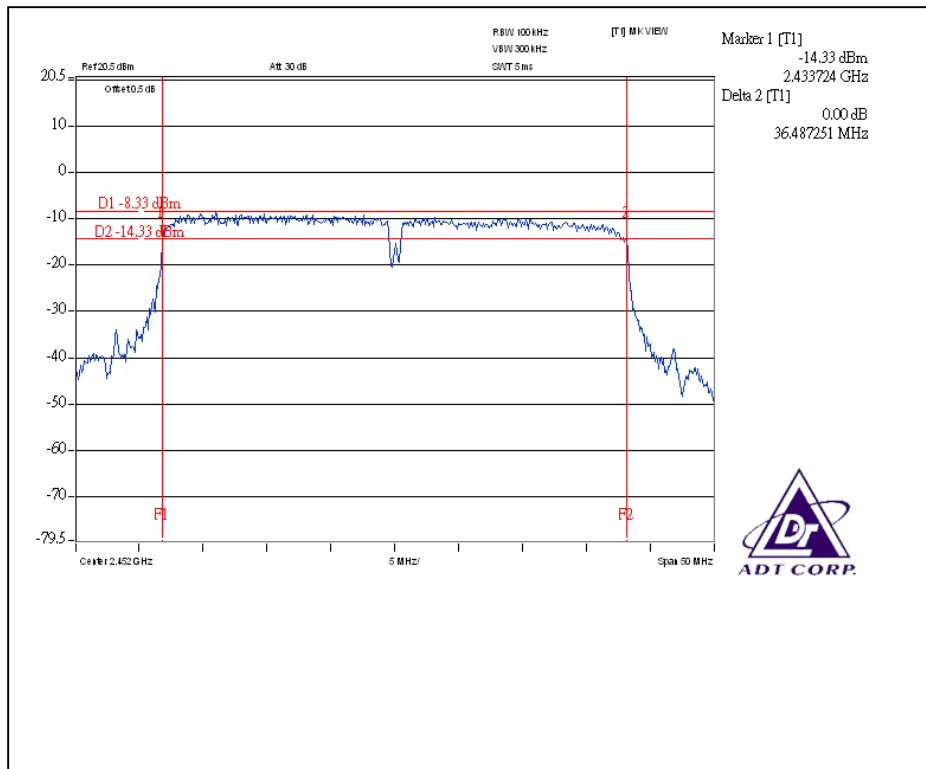

For Chain (1): CH1

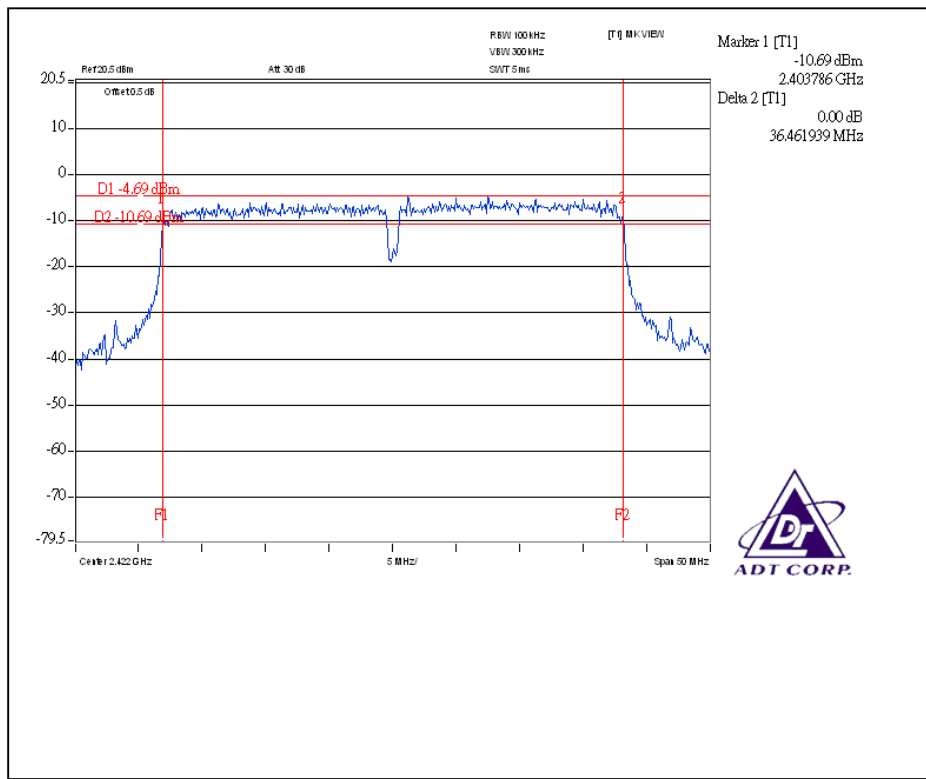

CH4

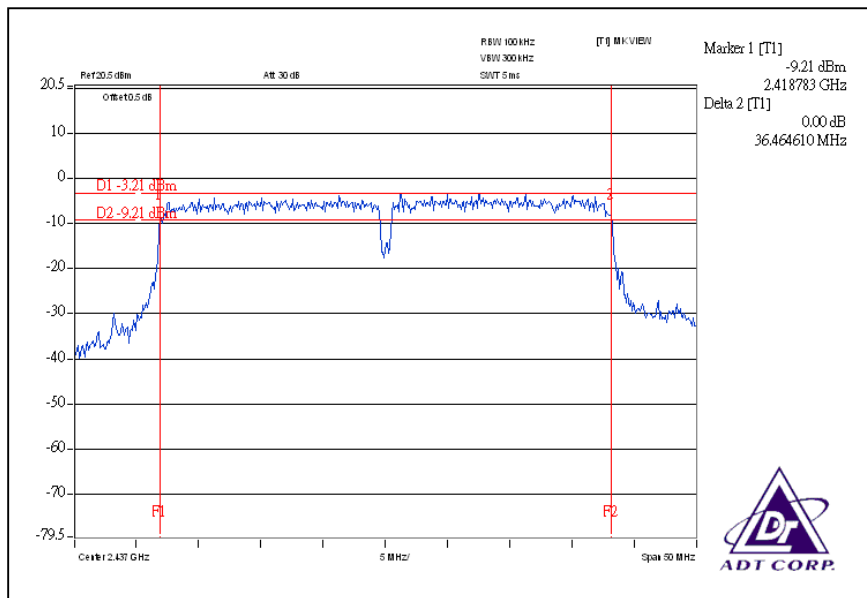

CH7

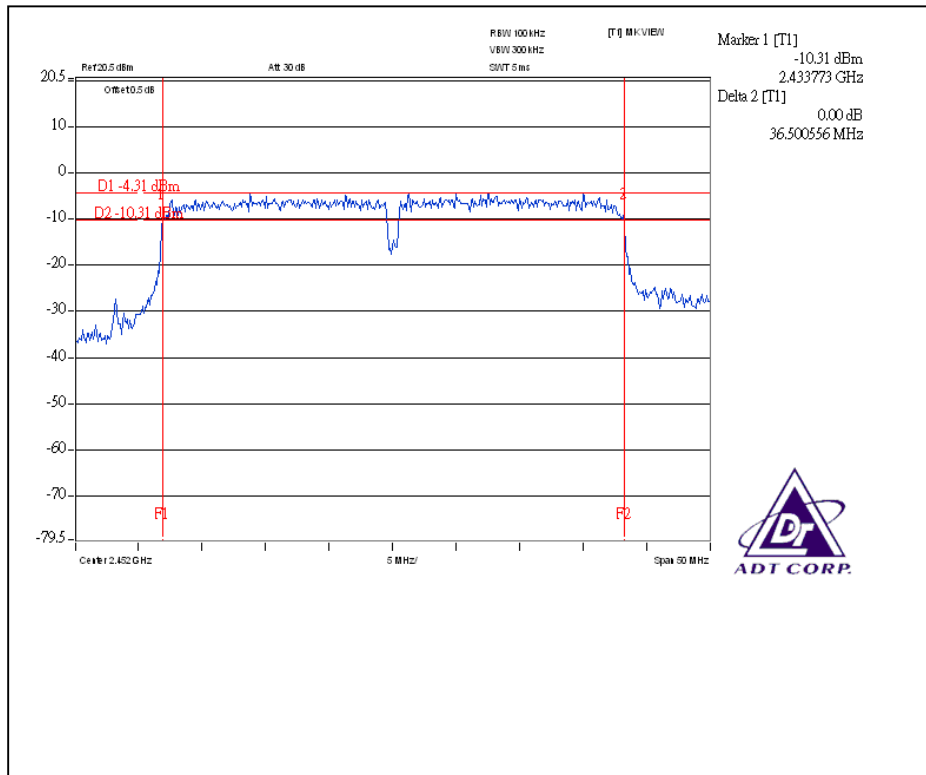



4.4 MAXIMUM PEAK OUTPUT POWER

4.4.1 LIMITS OF MAXIMUM PEAK OUTPUT POWER MEASUREMENT

The Maximum Peak Output Power Measurement is 30dBm.

4.4.2 INSTRUMENTS

Description & Manufacturer	Model No.	Serial No.	Calibrated Until
R&S SPECTRUM ANALYZER	FSP40	100037	Aug. 12, 2008
Agilent SIGNAL GENERATOR	E8257C	MY43320668	Dec. 25, 2008
TEKTRONIX OSCILLOSCOPE	TDS380	B016335	Aug. 15, 2008
NARDA DETECTOR	4503A	FSCM99899	NA

NOTE:

The calibration interval of the above test instruments is 12 months and the calibrations are traceable to NML/ROC and NIST/USA.

4.4.3 TEST PROCEDURES

1. A detector was used on the output port of the EUT. An oscilloscope was used to read the response of the detector.
2. Replaced the EUT by the signal generator. The center frequency of the S.G was adjusted to the center frequency of the measured channel.
3. Adjusted the power to have the same reading on oscilloscope. Record the power level.

4.4.4 DEVIATION FROM TEST STANDARD

No deviation

4.4.5 TEST SETUP



4.4.6 EUT OPERATING CONDITIONS

Same as Item 4.3.6

4.4.7 TEST RESULTS

802.11b DSSS MODULATION:

MODULATION TYPE	CCK	TRANSFER RATE	11Mbps
INPUT POWER	120Vac, 60 Hz	ENVIRONMENTAL CONDITIONS	19deg.C, 69%RH, 972hPa
TESTED BY	Phoenix Huang		

CHANNEL	CHANNEL FREQUENCY (MHz)	PEAK POWER OUTPUT (mW)	PEAK POWER OUTPUT (dBm)	PEAK POWER LIMIT (dBm)	PASS / FAIL
1	2412	18.197	12.60	30	PASS
6	2437	13.183	11.20	30	PASS
11	2462	14.125	11.50	30	PASS

802.11g OFDM MODULATION:

MODULATION TYPE	BPSK	TRANSFER RATE	6Mbps
INPUT POWER	120Vac, 60 Hz	ENVIRONMENTAL CONDITIONS	19deg.C, 69%RH, 972hPa
TESTED BY	Phoenix Huang		

CHANNEL	CHANNEL FREQUENCY (MHz)	PEAK POWER OUTPUT (mW)	PEAK POWER OUTPUT (dBm)	PEAK POWER LIMIT (dBm)	PASS / FAIL
1	2412	51.286	17.10	30	PASS
6	2437	54.954	17.40	30	PASS
11	2462	52.481	17.20	30	PASS

DRAFT 802.11n (20MHz) OFDM MODULATION:

MODULATION TYPE	BPSK	TRANSFER RATE	14.4Mbps
INPUT POWER	120Vac, 60 Hz	ENVIRONMENTAL CONDITIONS	23deg.C, 54%RH, 972hPa
TESTED BY	Phoenix Huang		

CHANNEL	CHANNEL FREQUENCY (MHz)	PEAK POWER OUTPUT (mW)		PEAK POWER OUTPUT (dBm)		TOTAL PEAK POWER (mW)	TOTAL PEAK POWER (dBm)	PEAK POWER LIMIT (dBm)	PASS / FAIL
		CHAIN(0)	CHAIN(1)	CHAIN(0)	CHAIN(1)				
1	2412	48.978	25.119	16.90	14.00	74.097	18.70	30	PASS
6	2437	52.481	52.481	17.20	17.20	104.962	20.21	30	PASS
11	2462	29.512	45.709	14.70	16.60	75.221	18.76	30	PASS

DRAFT 802.11n (40MHz) OFDM MODULATION:

MODULATION TYPE	BPSK	TRANSFER RATE	30Mbps
INPUT POWER	120Vac, 60 Hz	ENVIRONMENTAL CONDITIONS	23deg.C, 54%RH, 972hPa
TESTED BY	Phoenix Huang		

CHANNEL	CHANNEL FREQUENCY (MHz)	PEAK POWER OUTPUT (mW)		PEAK POWER OUTPUT (dBm)		TOTAL PEAK POWER (mW)	TOTAL PEAK POWER (dBm)	PEAK POWER LIMIT (dBm)	PASS / FAIL
		CHAIN(0)	CHAIN(1)	CHAIN(0)	CHAIN(1)				
1	2422	22.909	22.387	13.60	13.50	45.296	16.56	30	PASS
4	2437	38.905	37.154	15.90	15.70	76.059	18.81	30	PASS
7	2452	27.102	30.200	14.33	14.80	57.302	17.58	30	PASS



4.5 POWER SPECTRAL DENSITY MEASUREMENT

4.5.1 LIMITS OF POWER SPECTRAL DENSITY MEASUREMENT

The Maximum of Power Spectral Density Measurement is 8dBm.

4.5.2 TEST INSTRUMENTS

Description & Manufacturer	Model No.	Serial No.	Calibrated Until
R&S SPECTRUM ANALYZER	FSP40	100037	Aug. 12, 2008

NOTE:

- 1.The measurement uncertainty is less than +/- 2.6dB, which is calculated as per the NAMAS document NIS81. This uncertainty represents an expanded uncertainty expressed at approximately the 95% confidence level using a coverage factor of k=2.
- 2.The calibration interval of the above test instruments is 12 months and the calibrations are traceable to NML/ROC and NIST/USA.

4.5.3 TEST PROCEDURE

The transmitter output was connected to the spectrum analyzer through an attenuator, the bandwidth of the fundamental frequency was measured with the spectrum analyzer using 3kHz RBW and 30kHz VBW, set sweep time = span/3kHz. The power spectral density was measured and recorded.

The sweep time is allowed to be longer than span/3kHz for a full response of the mixer in the spectrum analyzer.

4.5.4 DEVIATION FROM TEST STANDARD

No deviation

4.5.5 TEST SETUP

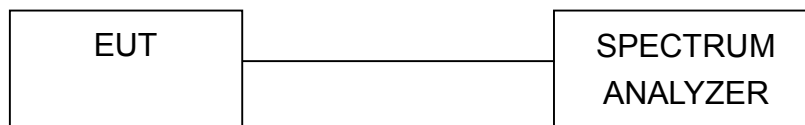

4.5.6 EUT OPERATING CONDITION

Same as Item 4.3.6

4.5.7 TEST RESULTS

802.11b DSSS MODULATION:

MODULATION TYPE	CCK	TRANSFER RATE	11Mbps
INPUT POWER	120Vac, 60 Hz	ENVIRONMENTAL CONDITIONS	19deg.C, 69%RH, 972hPa
TESTED BY	Phoenix Huang		

CHANNEL	CHANNEL FREQUENCY (MHz)	RF POWER LEVEL IN 3kHz BW (dBm)	MAXIMUM LIMIT (dBm)	PASS / FAIL
1	2412	-13.94	8	PASS
6	2437	-14.88	8	PASS
11	2462	-14.45	8	PASS

CH1

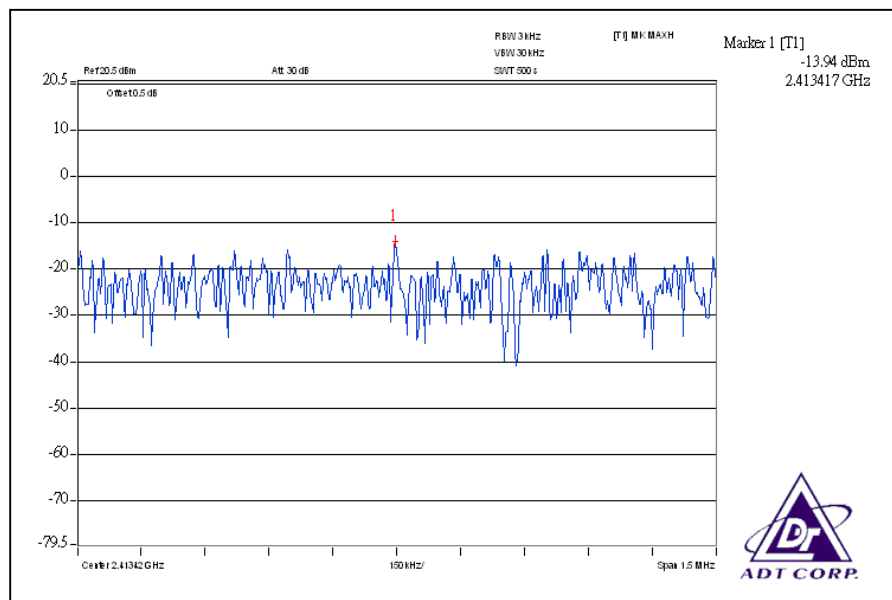

CH6

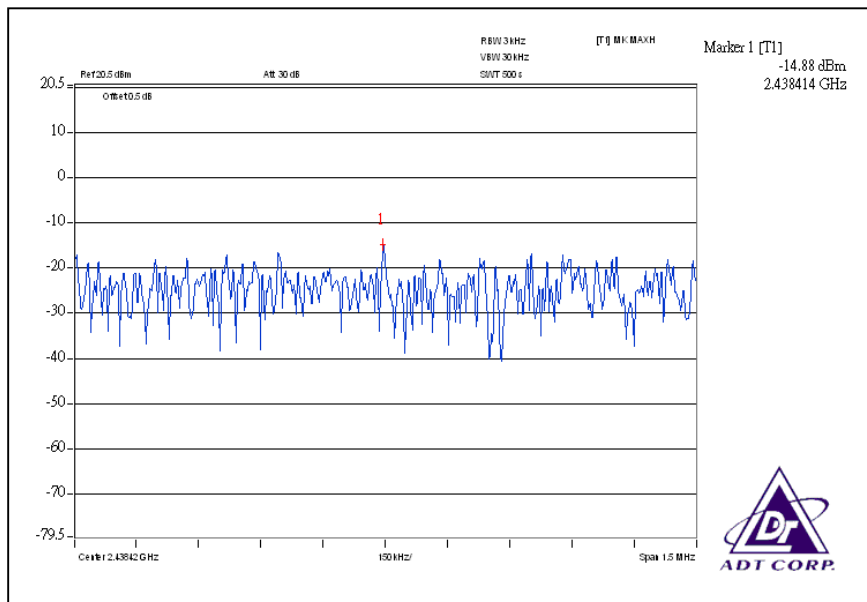

CH11

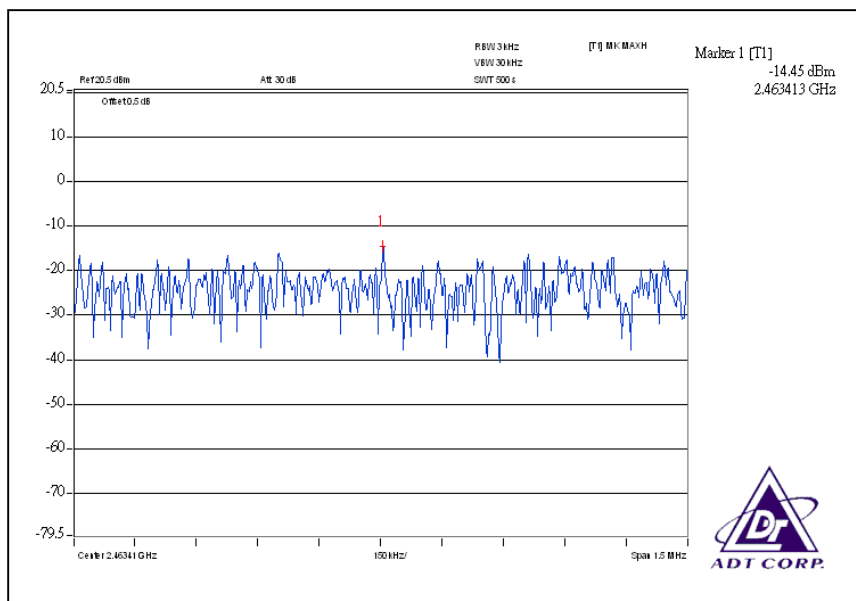

802.11g OFDM MODULATION:

MODULATION TYPE	BPSK	TRANSFER RATE	6Mbps
INPUT POWER	120Vac, 60 Hz	ENVIRONMENTAL CONDITIONS	19deg.C, 69%RH, 972hPa
TESTED BY	Phoenix Huang		

CHANNEL	CHANNEL FREQUENCY (MHz)	RF POWER LEVEL IN 3kHz BW (dBm)	MAXIMUM LIMIT (dBm)	PASS / FAIL
1	2412	-14.86	8	PASS
6	2437	-13.91	8	PASS
11	2462	-14.12	8	PASS

CH1

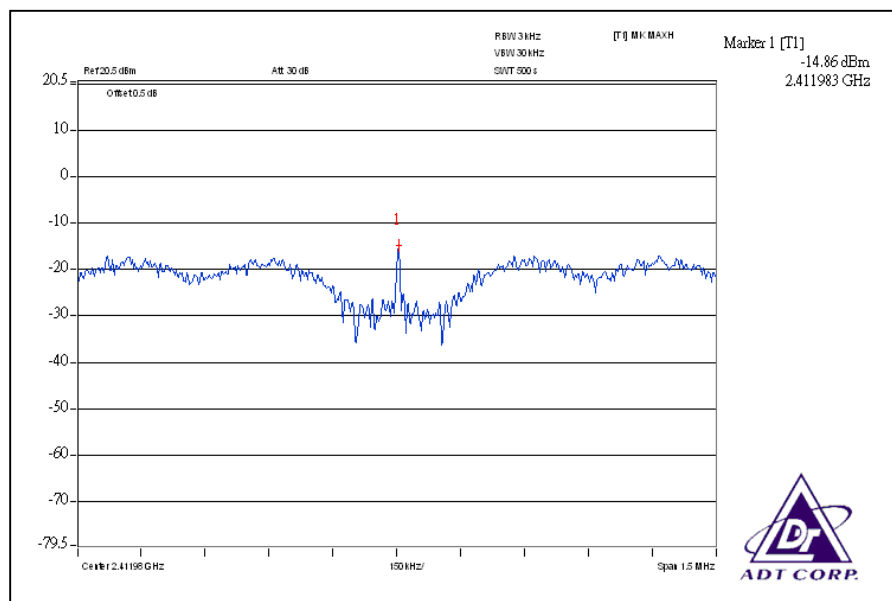

CH6

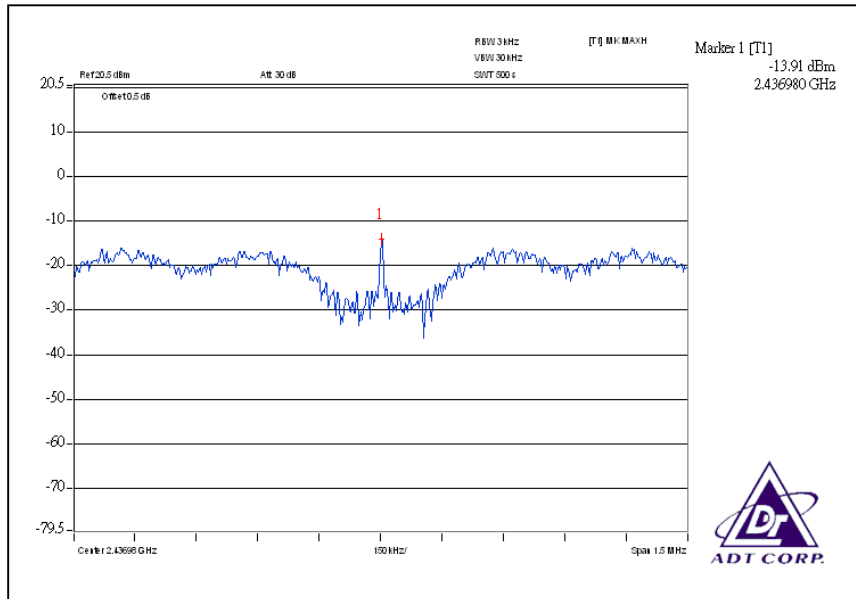

CH11

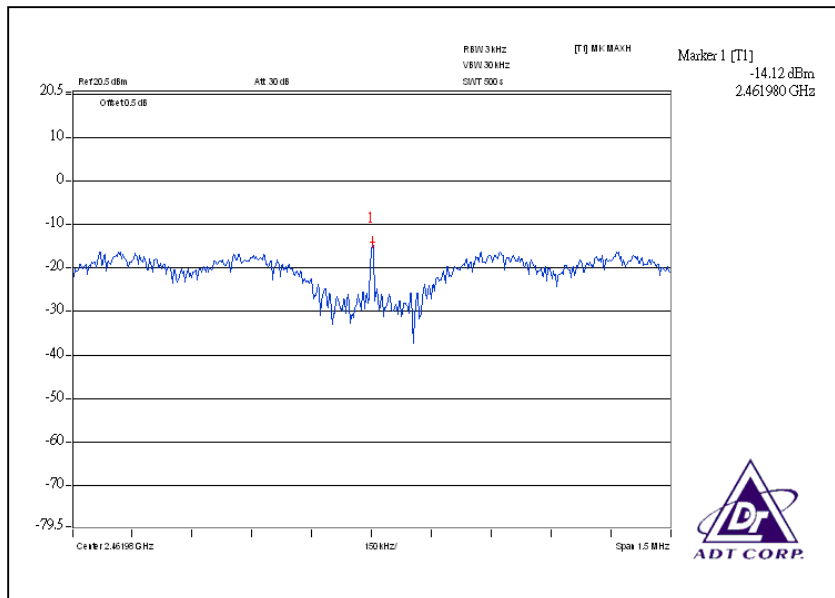

DRAFT 802.11n (20MHz) OFDM MODULATION:

MODULATION TYPE	BPSK	TRANSFER RATE	14.4Mbps
INPUT POWER	120Vac, 60 Hz	ENVIRONMENTAL CONDITIONS	23 deg.C, 54%RH, 972hPa
TESTED BY	Phoenix Huang		

CHANNEL	CHANNEL FREQUENCY (MHz)	RF POWER LEVEL IN 3kHz BW (mW)		RF POWER LEVEL IN 3kHz BW (dBm)		TOTAL POWER DENSITY (mW)	TOTAL POWER DENSITY (dBm)	MAXIMUM LIMIT (dBm)	PASS / FAIL
		CHAIN(0)	CHAIN(1)	CHAIN(0)	CHAIN(1)				
1	2412	0.032	0.010	-14.99	-19.84	0.042	-13.77	8	PASS
6	2437	0.040	0.023	-14.01	-16.35	0.063	-12.01	8	PASS
11	2462	0.024	0.020	-16.22	-16.98	0.044	-13.57	8	PASS

For Chain(0): CH1

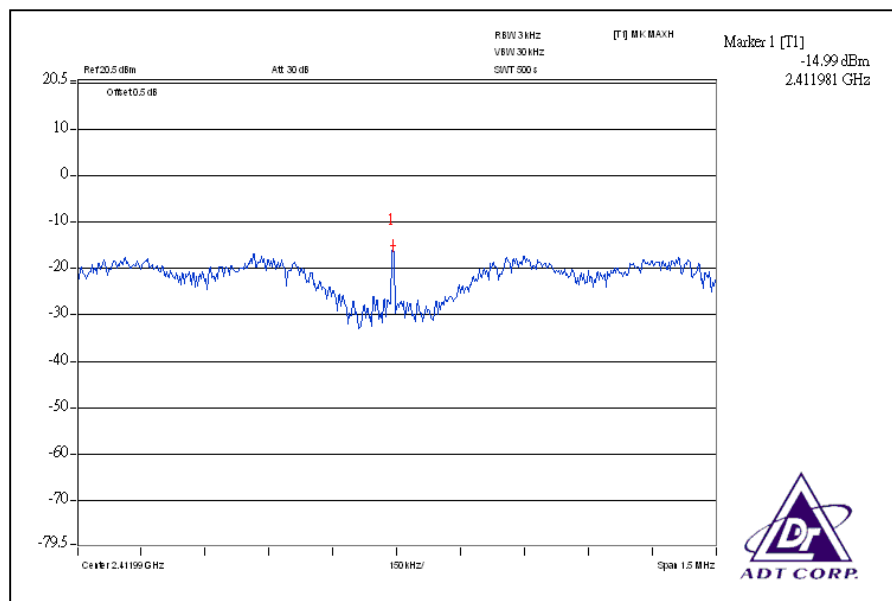

CH6

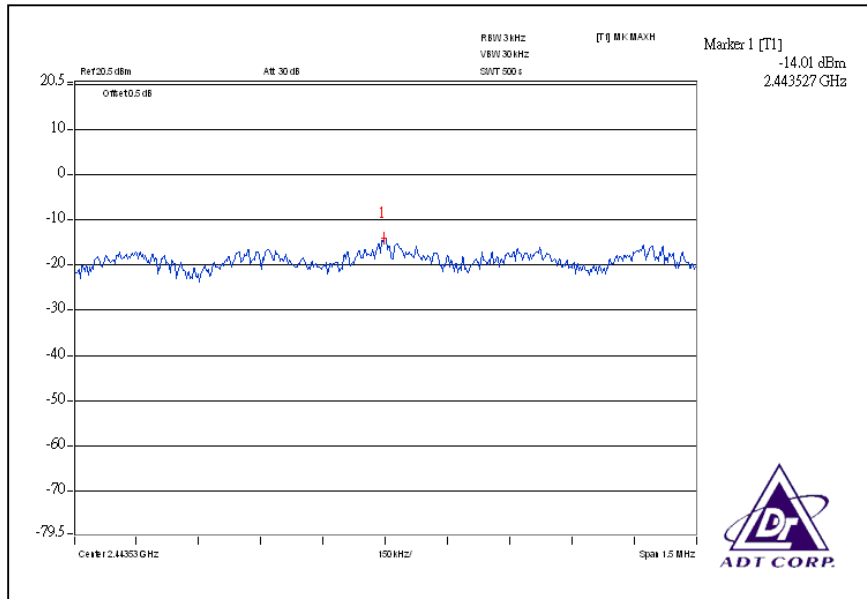

CH11

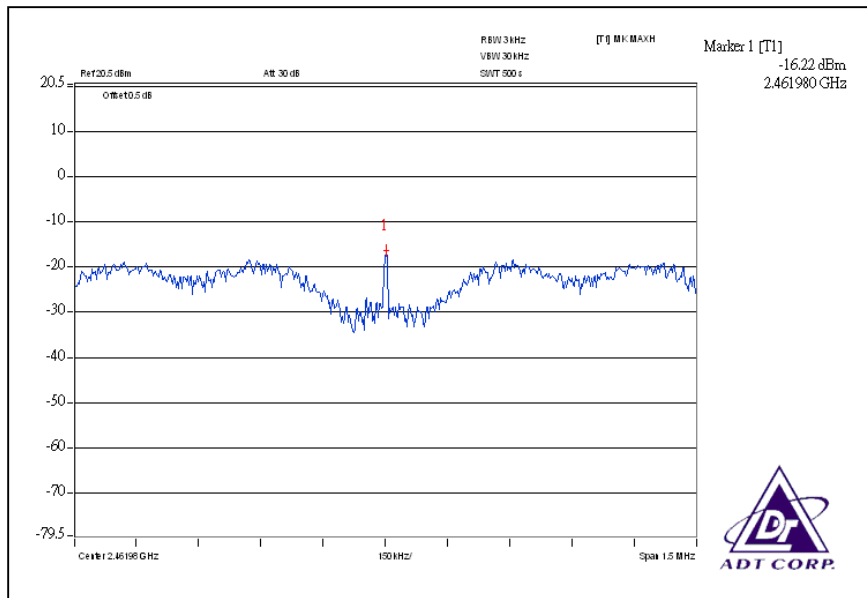

For Chain (1): CH1

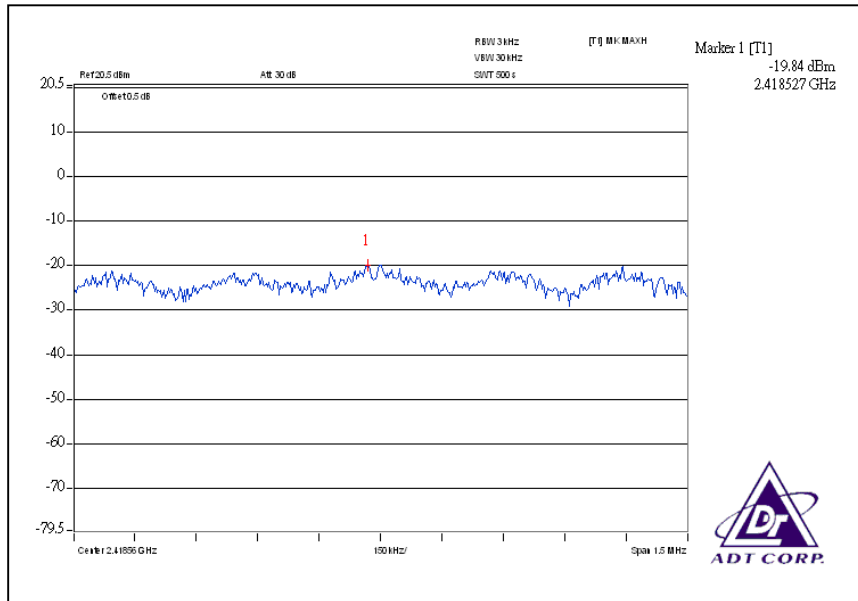

CH6

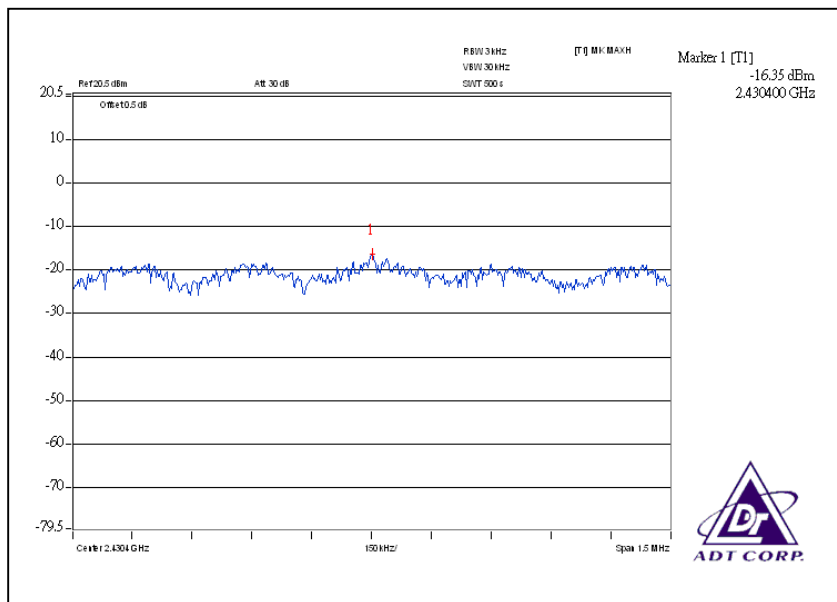

CH11

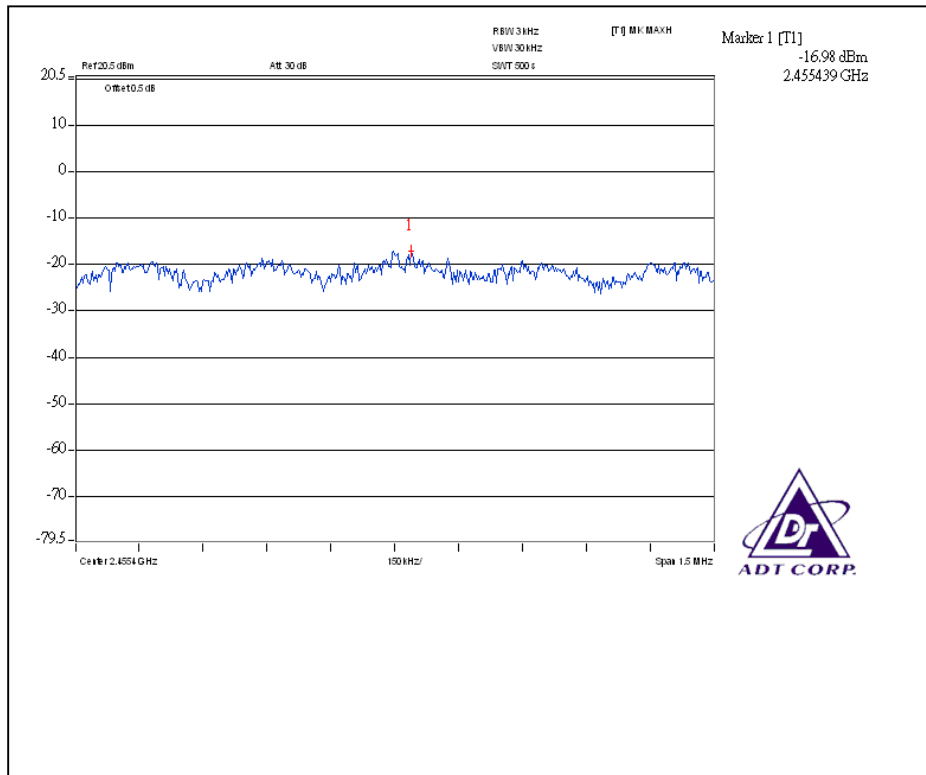

DRAFT 802.11n (40MHz) OFDM MODULATION:

MODULATION TYPE	BPSK	TRANSFER RATE	30Mbps
INPUT POWER	120Vac, 60 Hz	ENVIRONMENTAL CONDITIONS	23deg.C, 54%RH, 972hPa
TESTED BY	Phoenix Huang		

CHANNEL	CHANNEL FREQUENCY (MHz)	RF POWER LEVEL IN 3kHz BW (mW)		RF POWER LEVEL IN 3kHz BW (dBm)		TOTAL POWER DENSITY (mW)	TOTAL POWER DENSITY (dBm)	MAXIMUM LIMIT (dBm)	PASS / FAIL
		CHAIN(0)	CHAIN(1)	CHAIN(0)	CHAIN(1)				
1	2422	0.036	0.010	-14.48	-20.22	0.046	-13.37	8	PASS
4	2437	0.028	0.016	-15.57	-17.93	0.044	-13.57	8	PASS
7	2452	0.028	0.015	-15.57	-18.11	0.043	-13.67	8	PASS

For Chain (0): CH1

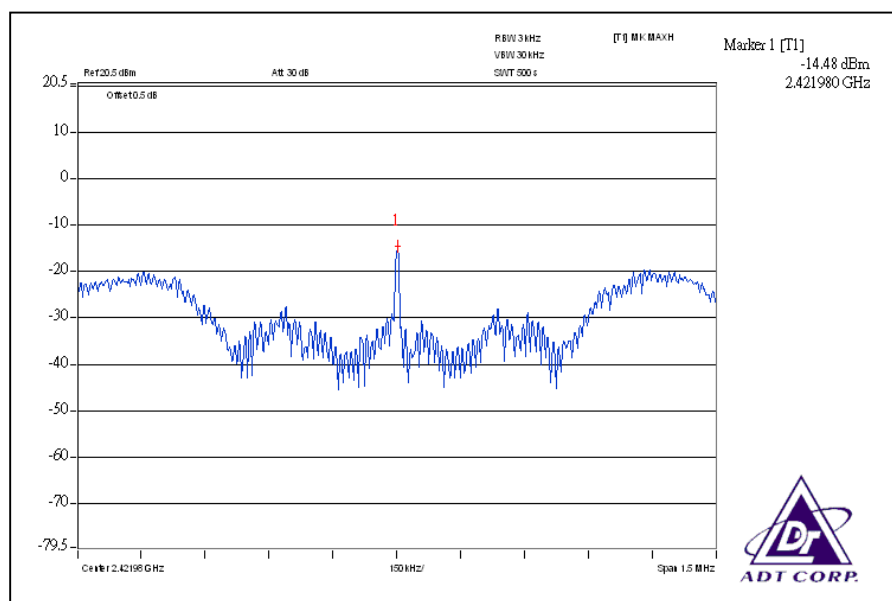

CH4

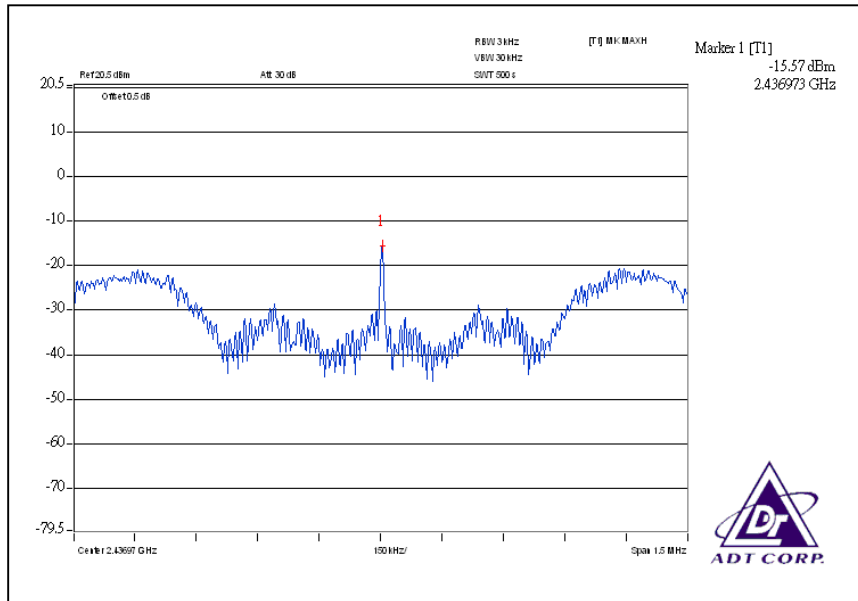

CH7

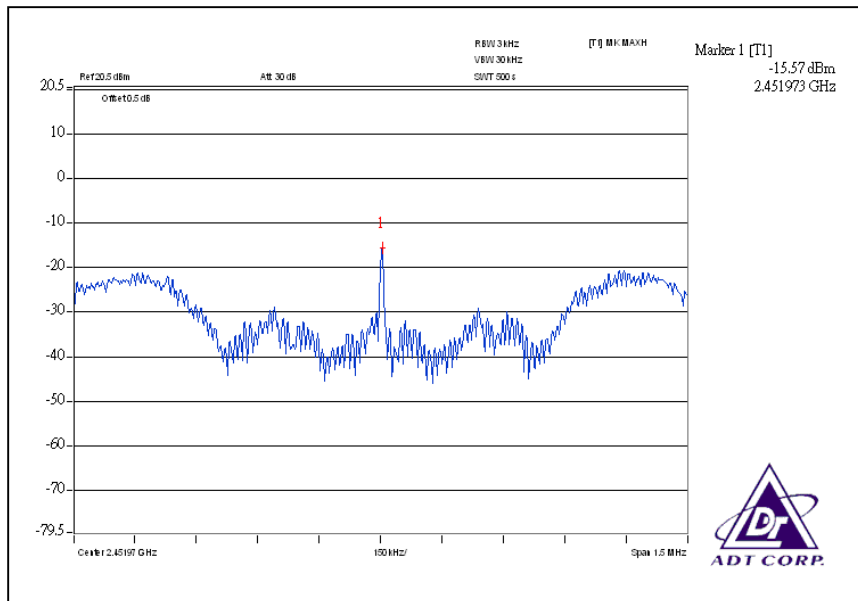

For Chain (1): CH1

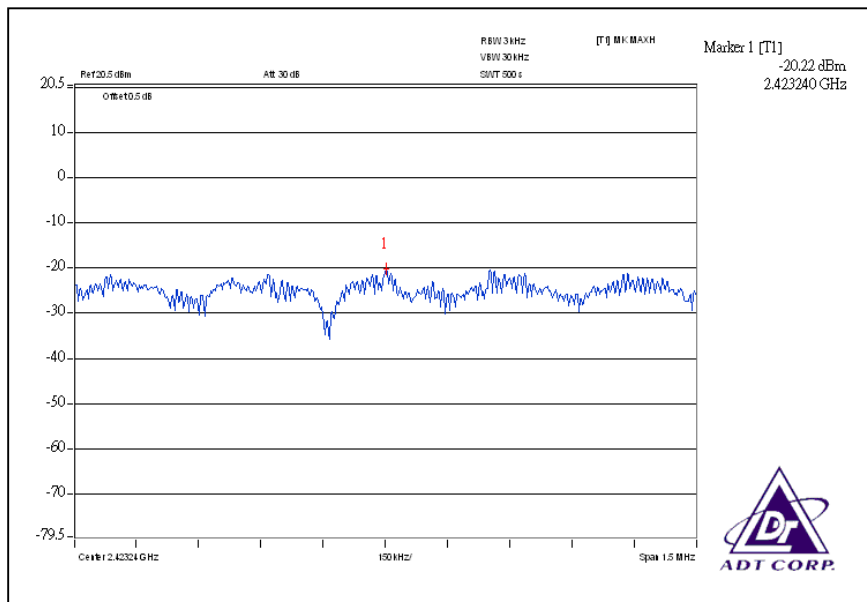

CH4

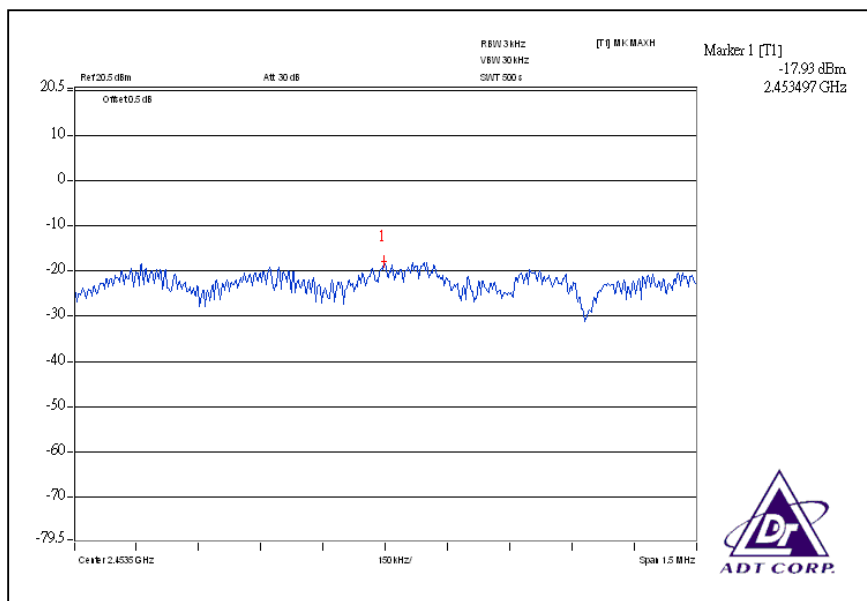

CH7

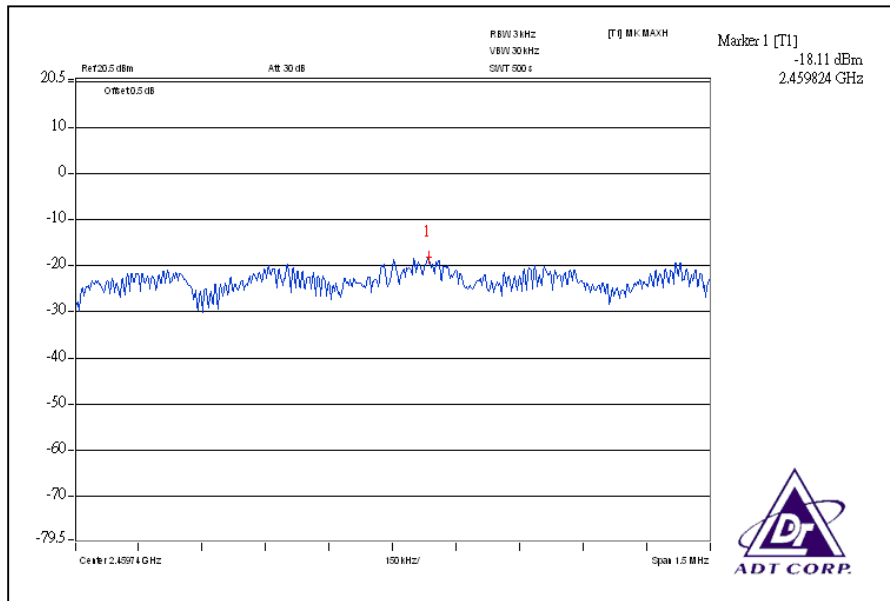

4.6 BAND EDGES MEASUREMENT

4.6.1 LIMITS OF BAND EDGES MEASUREMENT

Below -20dB of the highest emission level of operating band (in 100KHz Resolution Bandwidth).

4.6.2 TEST INSTRUMENTS

Description & Manufacturer	Model No.	Serial No.	Calibrated Until
R&S SPECTRUM ANALYZER	FSP40	100037	Aug. 12, 2008

NOTE:

- 1.The measurement uncertainty is less than $\pm 2.6\text{dB}$, which is calculated as per the NAMAS document NIS81. This uncertainty represents an expanded uncertainty expressed at approximately the 95% confidence level using a coverage factor of $k=2$.
- 2.The calibration interval of the above test instruments is 12 months and the calibrations are traceable to NML/ROC and NIST/USA.

4.6.3 TEST PROCEDURE

The transmitter output was connected to the spectrum analyzer via a low lose cable. Set both RBW of spectrum analyzer to 100kHz and VBW of spectrum analyzer to 300kHz with suitable frequency span including 100 MHz bandwidth from band edge. The band edges was measured and recorded.

The spectrum plots (RBW = 100kHz, VBW = 300kHz) are attached on the following pages.

4.6.4 DEVIATION FROM TEST STANDARD

No deviation

4.6.5 EUT OPERATING CONDITION

Same as Item 4.3.6

4.6.6 TEST RESULTS

The spectrum plots are attached on the following below images. D1 line indicates the highest level, and D2 line indicates the 20dB offset below D1. It shows compliance with the requirement in part 15.247(d).

802.11b DSSS MODULATION: CH1

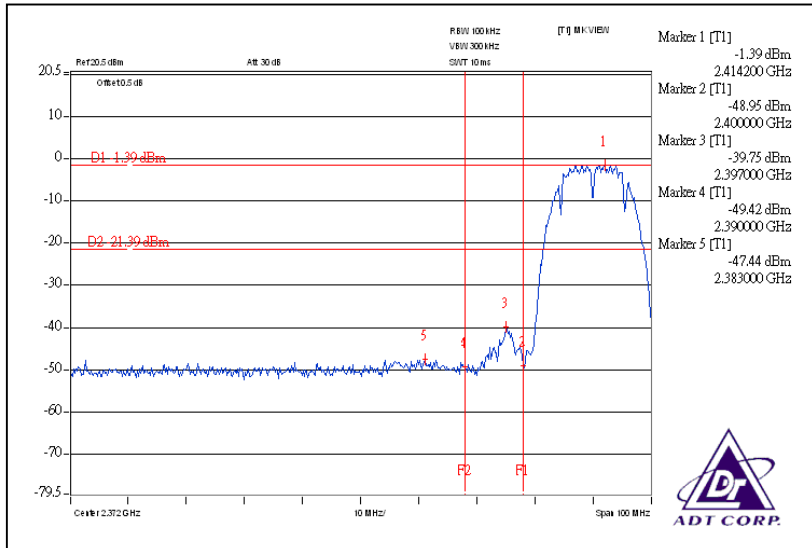

CH11

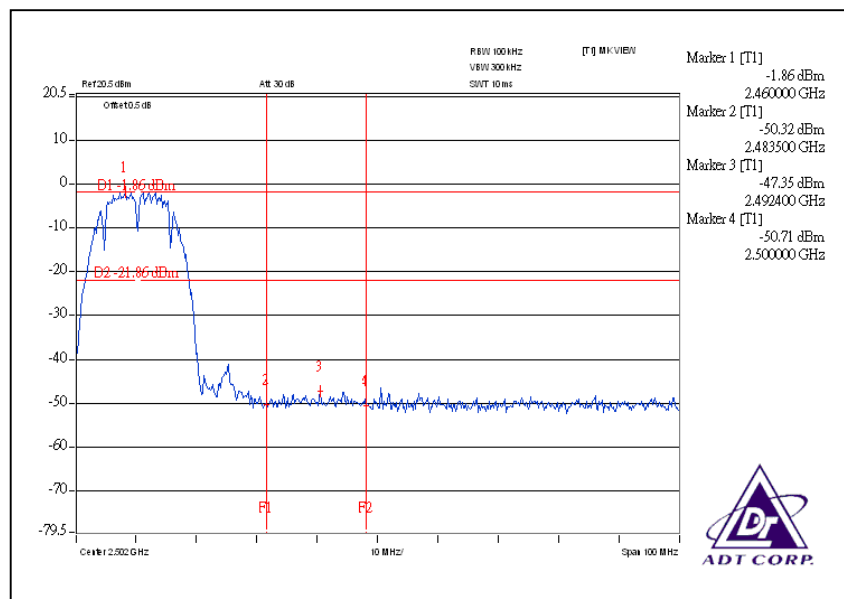

CH1

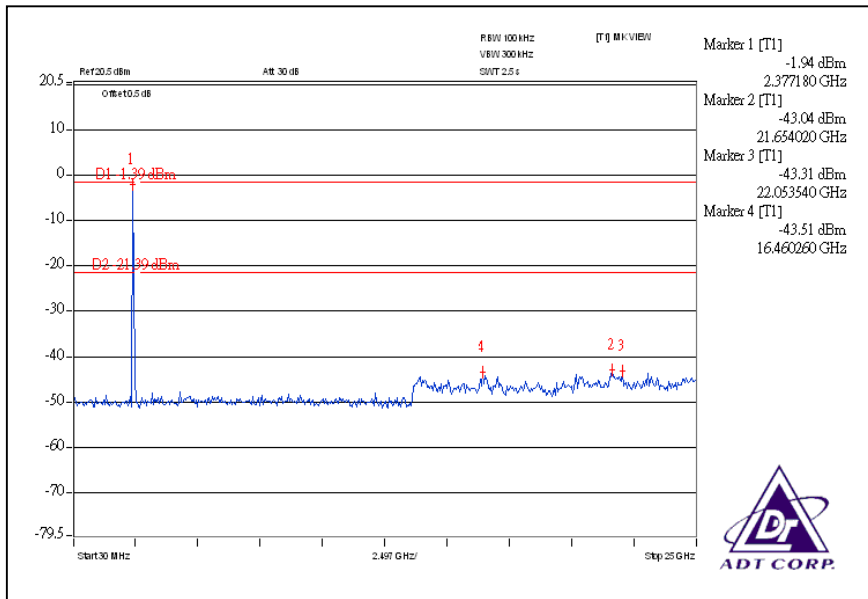

CH11

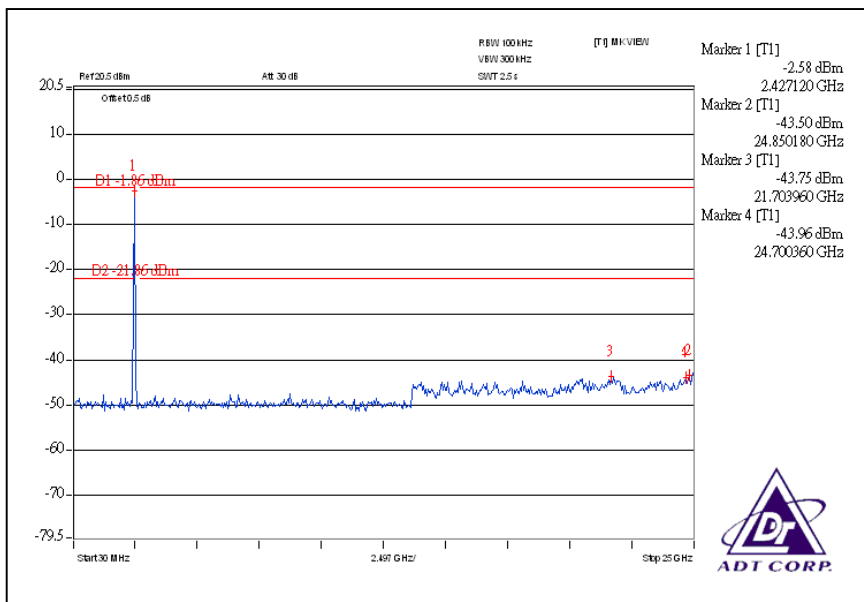

802.11g OFDM MODULATION:

CH 1

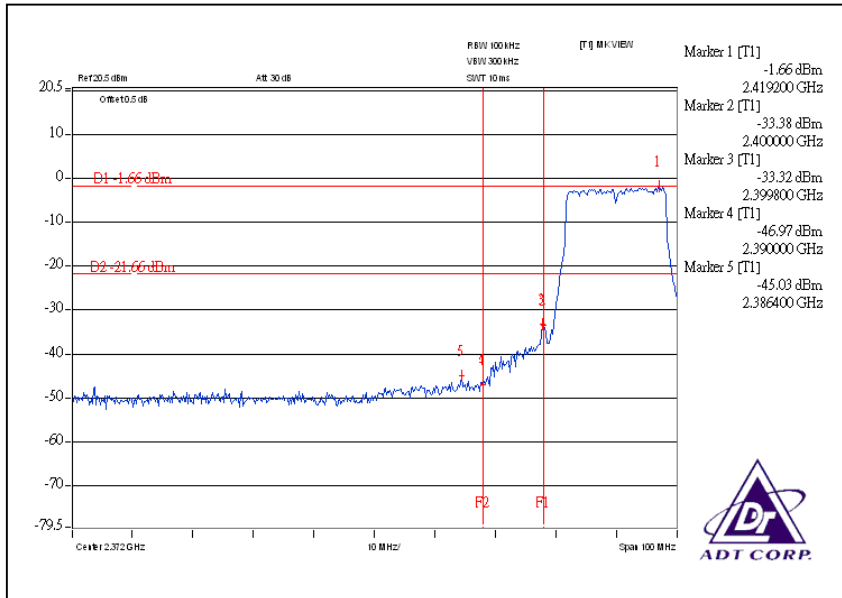

CH11

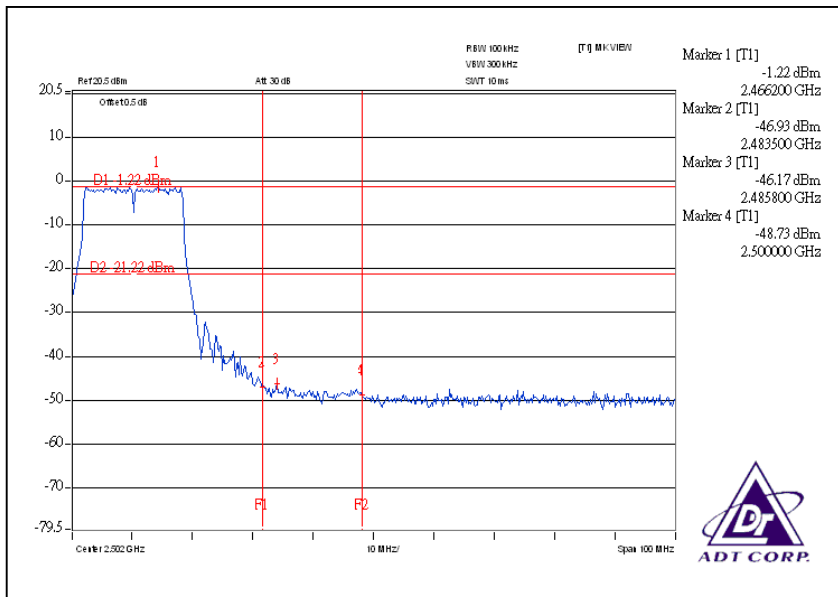

CH1

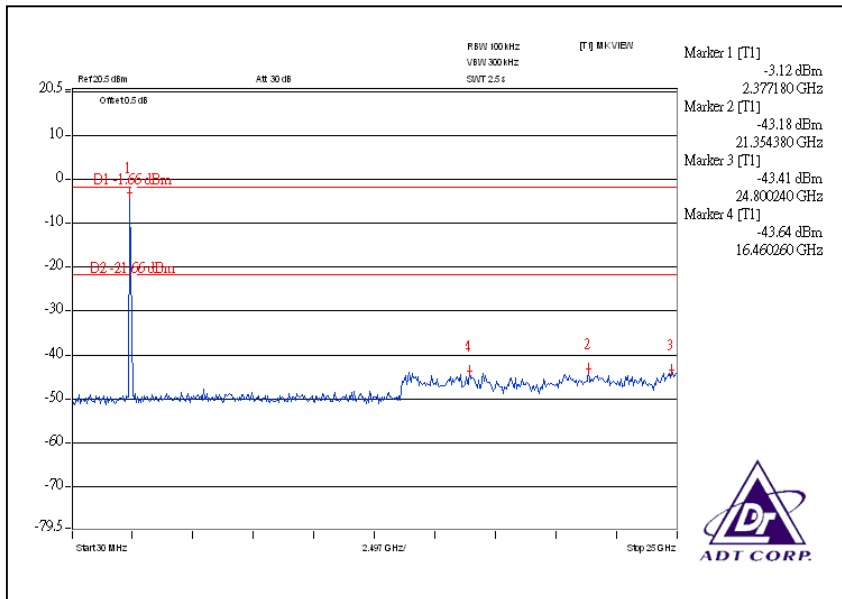

CH11

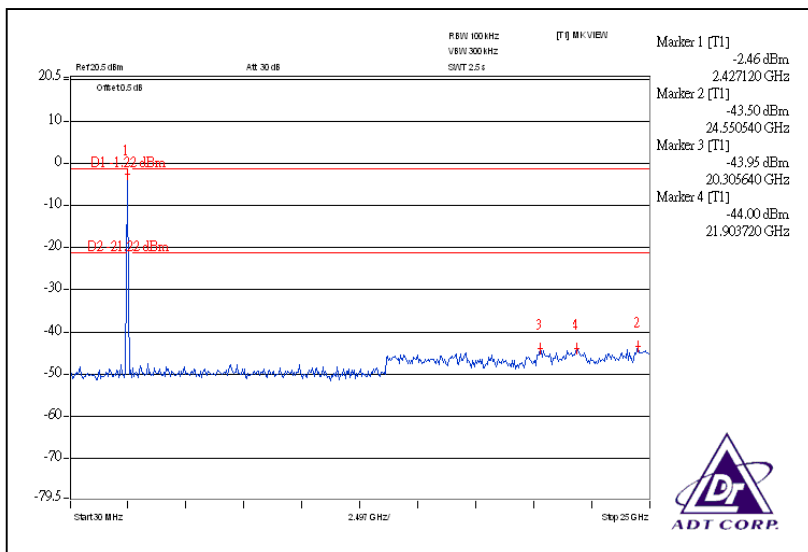

**DRAFT 802.11n (20MHz) OFDM MODULATION:
For Chain (0):CH1**

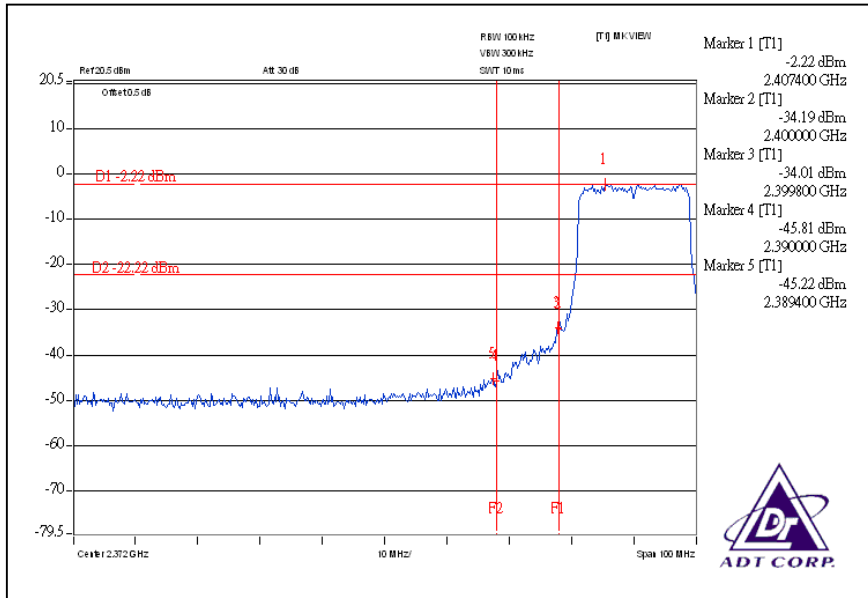

CH11

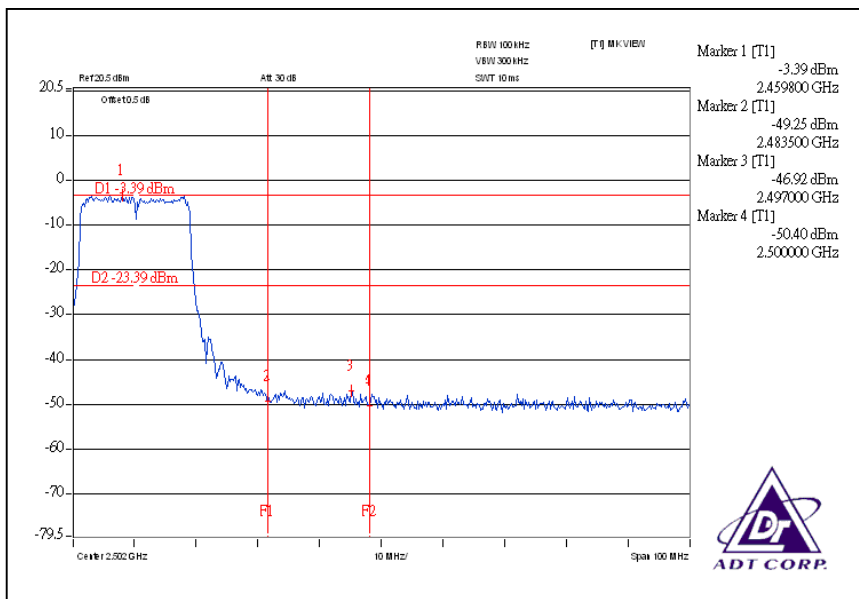

CH1

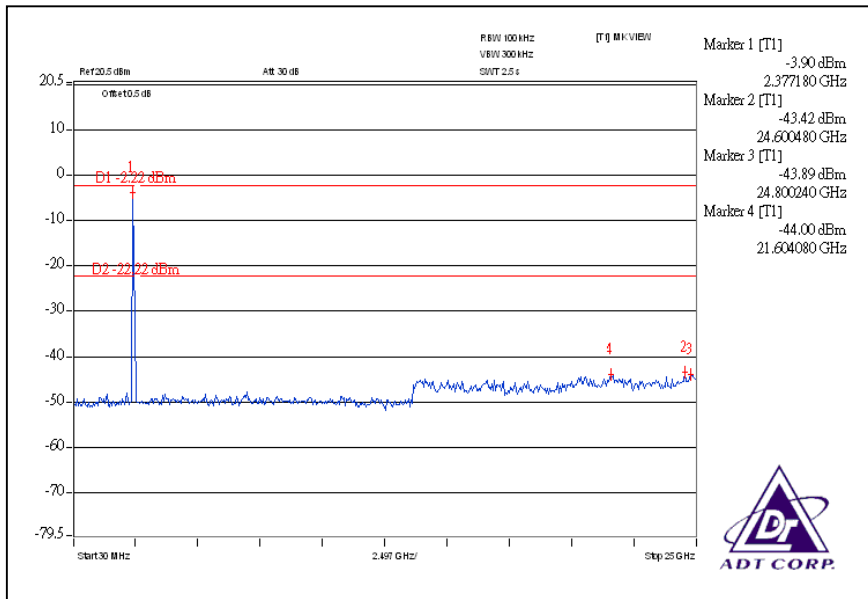

CH11

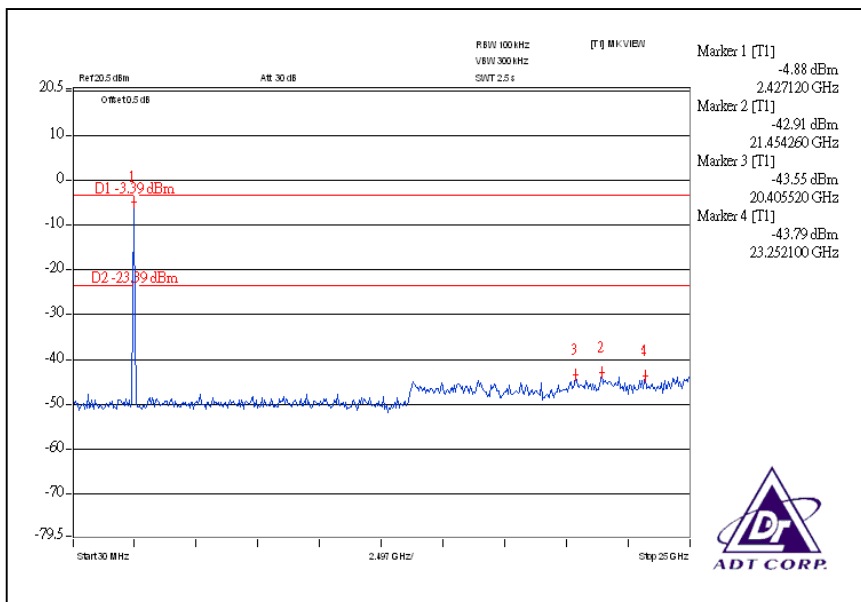

For Chain (1):CH1

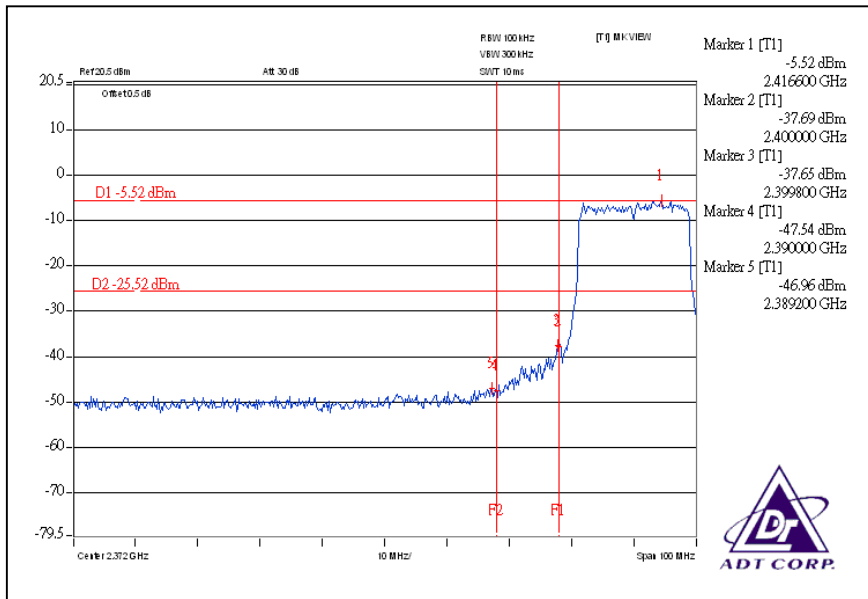

CH11

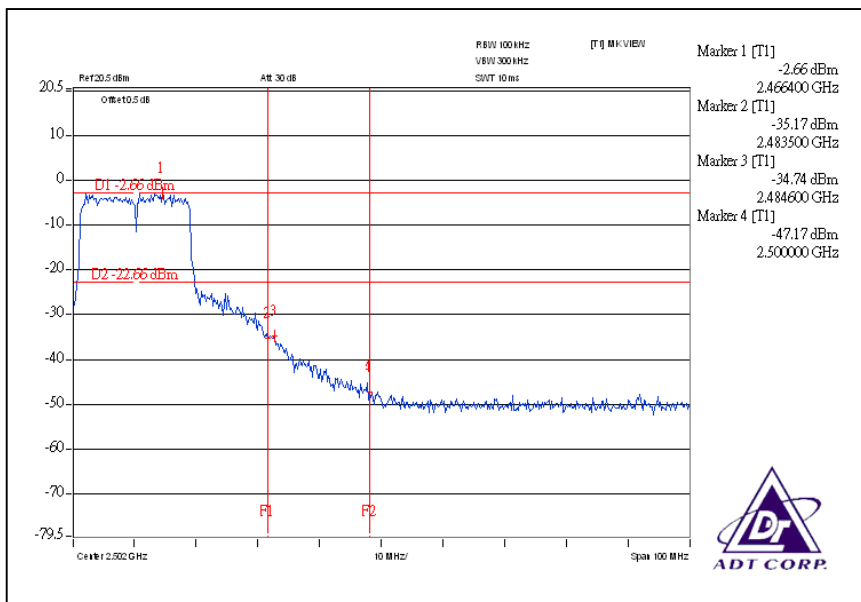

CH1

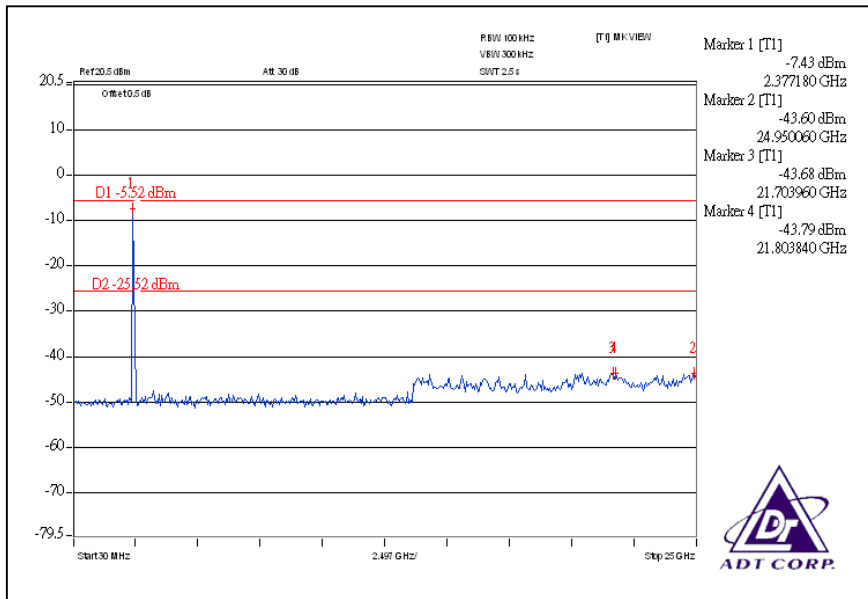

CH11

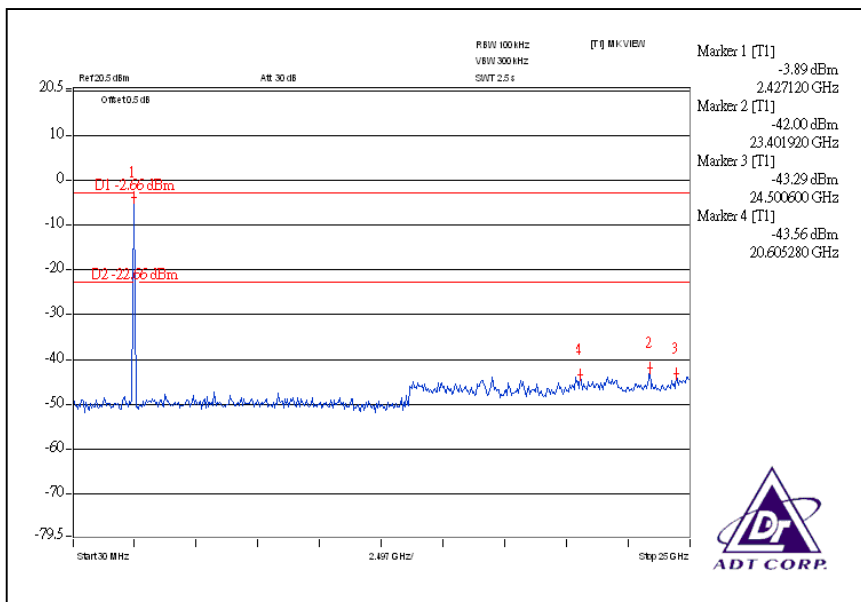

DRAFT 802.11n (40MHz) OFDM MODULATION:
For Chain (0):CH1

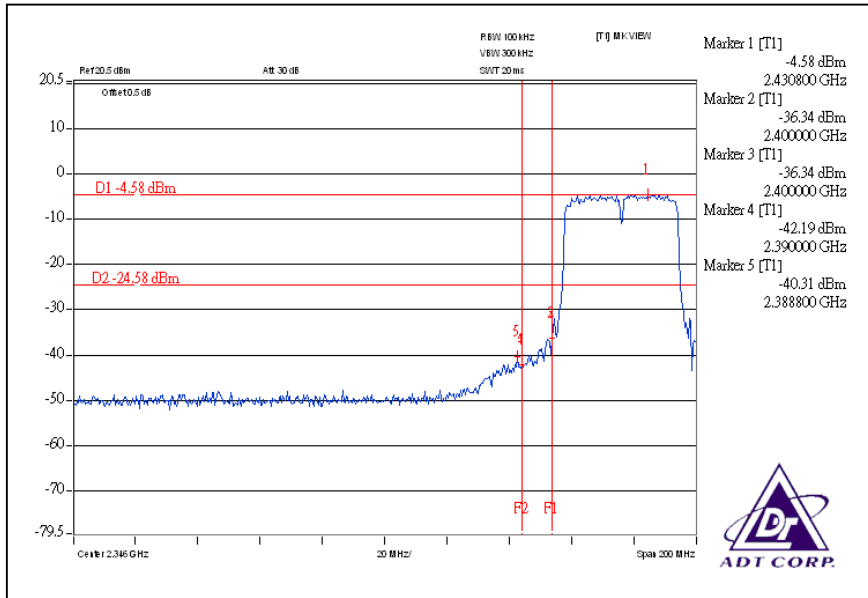

CH7

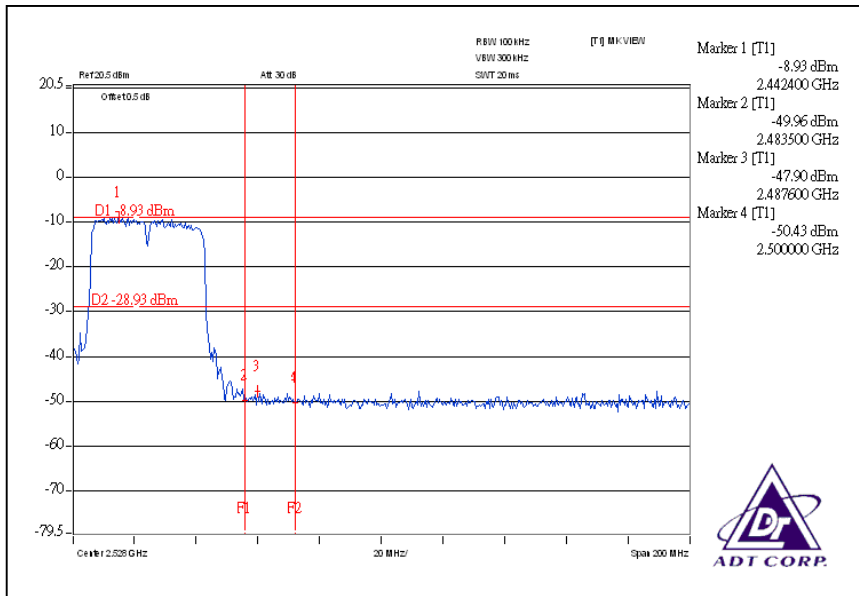

CH1

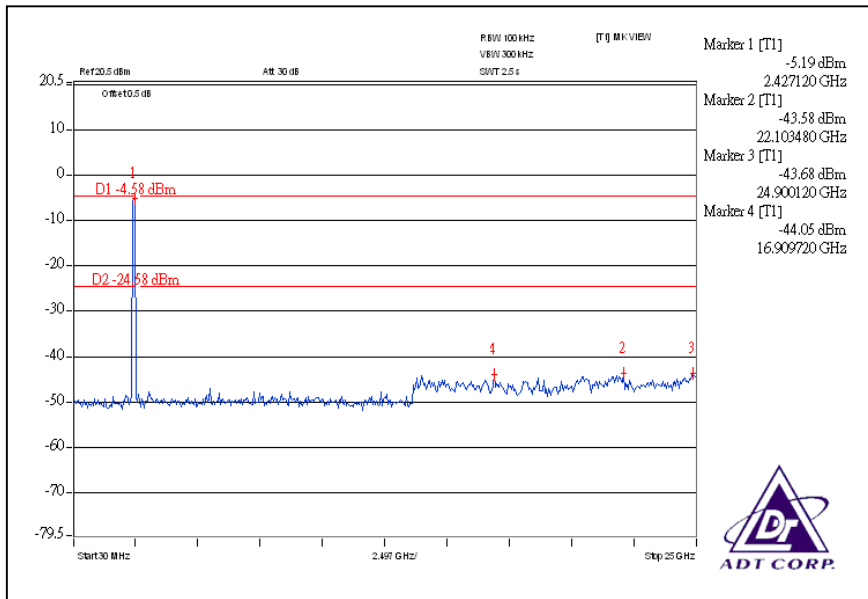

CH7

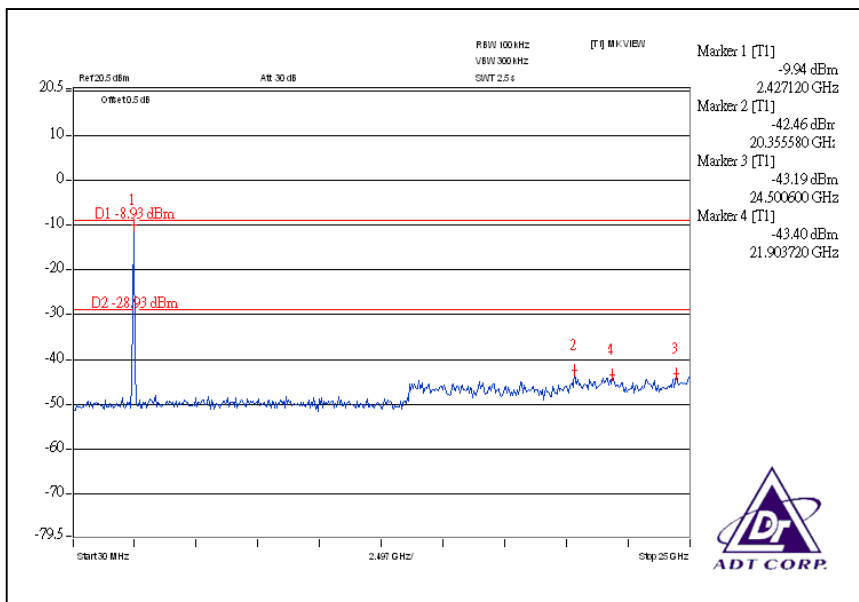

For Chain (1):CH1

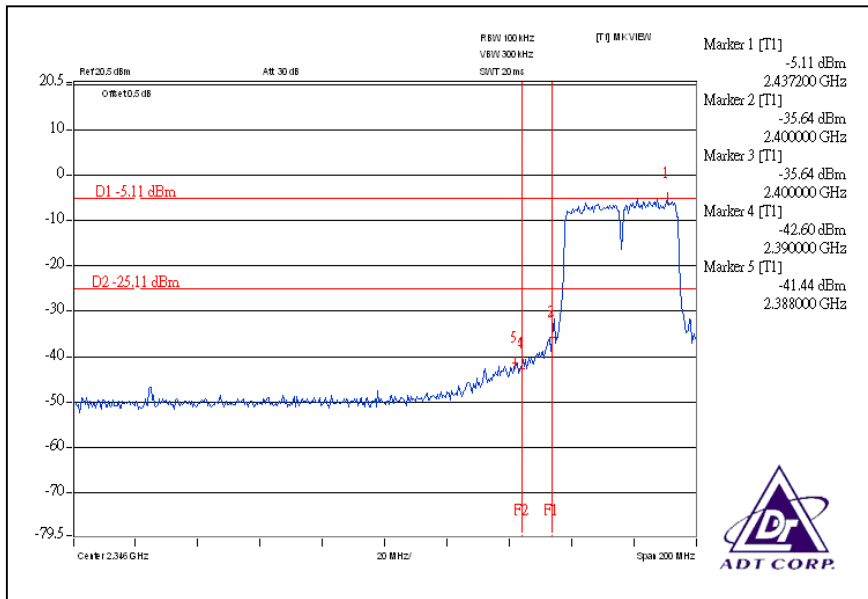

CH7

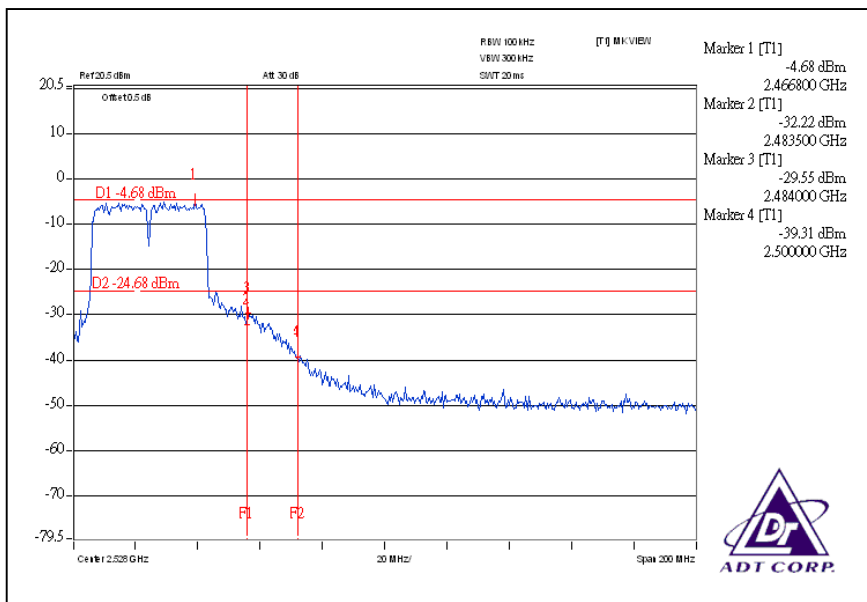

CH1

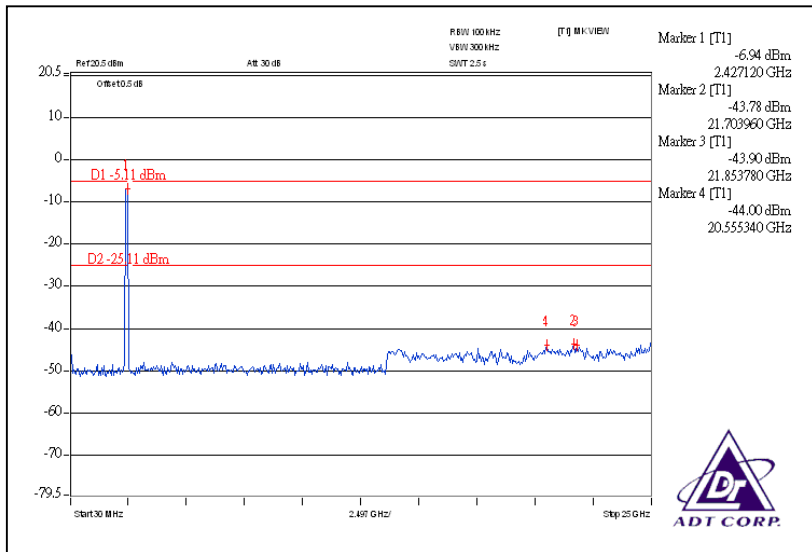

CH7

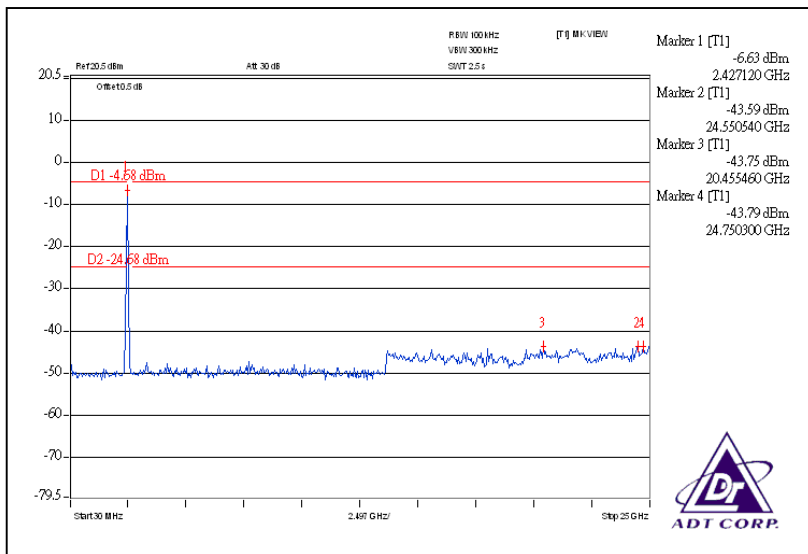

4.7 ANTENNA REQUIREMENT

4.7.1 STANDARD APPLICABLE

For intentional device, according to FCC 47 CFR Section 15.203, an intentional radiator shall be designed to ensure that no antenna other than that furnished by the responsible party shall be used with the device. And according to FCC 47 CFR Section 15.247 (b), if transmitting antennas of directional gain greater than 6dBi are used, the power shall be reduced by the amount in dB that the directional gain of the antenna exceeds 6dBi.

4.7.2 ANTENNA CONNECTED CONSTRUCTION

There are three antennas provided to this EUT, please refer to the following table:

Transmitter Circuit	Antenna Type	Antenna Connector	Gain(dBi)
Chain(0)	Dipole	REVERSE SMA	2
Chain(1)	Dipole	REVERSE SMA	2
Chain(2)	Dipole	REVERSE SMA	2



5. INFORMATION ON THE TESTING LABORATORIES

We, ADT Corp., were founded in 1988 to provide our best service in EMC, Radio, Telecom and Safety consultation. Our laboratories are accredited and approved by the following approval agencies according to ISO/IEC 17025.

USA	FCC, UL, A2LA
Germany	TUV Rheinland
Japan	VCCI
Norway	NEMKO
Canada	INDUSTRY CANADA , CSA
R.O.C.	TAF, BSMI, NCC
Netherlands	Telefication
Singapore	GOST-ASIA(MOU)
Russia	CERTIS(MOU)

Copies of accreditation certificates of our laboratories obtained from approval agencies can be downloaded from our web site:

www.adt.com.tw/index.5/phtml. If you have any comments, please feel free to contact us at the following:

Linko EMC/RF Lab:
Tel: 886-2-26052180
Fax: 886-2-26052943

Hsin Chu EMC/RF Lab:
Tel: 886-3-5935343
Fax: 886-3-5935342

Hwa Ya EMC/RF/Safety Telecom Lab:
Tel: 886-3-3183232
Fax: 886-3-3185050

Web Site: www.adt.com.tw

The address and road map of all our labs can be found in our web site also

6. APPENDIX A - MODIFICATIONS RECORDERS FOR ENGINEERING CHANGES TO THE EUT BY THE LAB

No any modifications are made to the EUT by the lab during the test.