



# FCC TEST REPORT

**REPORT NO.:** RF981214H03

**MODEL NO.:** W141C

**RECEIVED:** Dec. 14, 2009

**TESTED:** Dec. 30, 2009 to Jan. 13, 2010

**ISSUED:** Jan. 19, 2010

**APPLICANT:** NETRONIX, INC.

**ADDRESS:** No. 945, Boai St., Jubei City, Hsin-Chu, 302,  
Taiwan, R.O.C.

**ISSUED BY:** Bureau Veritas Consumer Products Services (H.K.)  
Ltd., Taoyuan Branch Hsin Chu Laboratory

**ADDRESS:** No. 81-1, Lu Liao Keng, 9th Ling, Wu Lung Tsuen,  
Chiung Lin Hsiang, Hsin Chu Hsien 307, Taiwan

This test report consists of 81 pages in total. It may be duplicated completely for legal use with the approval of the applicant. It should not be reproduced except in full, without the written approval of our laboratory. The client should not use it to claim product endorsement by TAF or any government agencies. The test results in the report only apply to the tested sample.





## Table of Contents

1.	CERTIFICATION .....	4
2.	SUMMARY OF TEST RESULTS .....	5
2.1	MEASUREMENT UNCERTAINTY .....	6
3.	GENERAL INFORMATION.....	7
3.1	GENERAL DESCRIPTION OF EUT .....	7
3.2	DESCRIPTION OF TEST MODES .....	9
3.2.1	TEST MODE APPLICABILITY AND TESTED CHANNEL DETAIL .....	10
3.3	GENERAL DESCRIPTION OF APPLIED STANDARDS .....	13
3.4	DESCRIPTION OF SUPPORT UNITS.....	14
3.5	CONFIGURATION OF SYSTEM UNDER TEST .....	15
4.	TEST TYPES AND RESULTS .....	18
4.1	CONDUCTED EMISSION MEASUREMENT.....	18
4.1.1	LIMITS OF CONDUCTED EMISSION MEASUREMENT .....	18
4.1.2	TEST INSTRUMENTS .....	18
4.1.3	TEST PROCEDURES.....	19
4.1.4	DEVIATION FROM TEST STANDARD .....	19
4.1.5	TEST SETUP .....	20
4.1.6	EUT OPERATING CONDITIONS .....	20
4.1.7	TEST RESULTS .....	21
4.2	RADIATED EMISSION MEASUREMENT .....	25
4.2.1	LIMITS OF RADIATED EMISSION MEASUREMENT.....	25
4.2.2	TEST INSTRUMENTS .....	26
4.2.3	TEST PROCEDURES.....	27
4.2.4	DEVIATION FROM TEST STANDARD .....	27
4.2.5	TEST SETUP .....	28
4.2.6	EUT OPERATING CONDITIONS .....	28
4.2.7	TEST RESULTS .....	29
4.3	6dB BANDWIDTH MEASUREMENT .....	58
4.3.1	LIMITS OF 6dB BANDWIDTH MEASUREMENT.....	58
4.3.2	TEST INSTRUMENTS .....	58
4.3.3	TEST PROCEDURE.....	58
4.3.4	DEVIATION FROM TEST STANDARD .....	58
4.3.5	TEST SETUP .....	58
4.3.6	EUT OPERATING CONDITIONS .....	58
4.3.7	TEST RESULTS .....	59
4.4	MAXIMUM PEAK OUTPUT POWER.....	63
4.4.1	LIMITS OF MAXIMUM PEAK OUTPUT POWER MEASUREMENT .....	63
4.4.2	INSTRUMENTS.....	63
4.4.3	TEST PROCEDURES.....	63
4.4.4	DEVIATION FROM TEST STANDARD .....	63



A D T

4.4.5	TEST SETUP .....	63
4.4.6	EUT OPERATING CONDITIONS .....	63
4.4.7	TEST RESULTS .....	64
4.5	POWER SPECTRAL DENSITY MEASUREMENT.....	66
4.5.1	LIMITS OF POWER SPECTRAL DENSITY MEASUREMENT .....	66
4.5.2	TEST INSTRUMENTS .....	66
4.5.3	TEST PROCEDURE .....	66
4.5.4	DEVIATION FROM TEST STANDARD .....	66
4.5.5	TEST SETUP .....	66
4.5.6	EUT OPERATING CONDITION.....	66
4.5.7	TEST RESULTS .....	67
4.6	CONDUCTED OUT-BAND EMISSION MEASUREMENT .....	71
4.6.1	LIMITS OF CONDUCTED OUT-BAND EMISSION MEASUREMENT.....	71
4.6.2	TEST INSTRUMENTS .....	71
4.6.3	TEST PROCEDURE .....	71
4.6.4	DEVIATION FROM TEST STANDARD .....	71
4.6.5	EUT OPERATING CONDITION.....	71
4.6.6	TEST RESULTS .....	71
5.	INFORMATION ON THE TESTING LABORATORIES .....	80
6.	APPENDIX A - MODIFICATIONS RECORDERS FOR ENGINEERING CHANGES TO THE EUT BY THE LAB .....	81



## 1. CERTIFICATION

**PRODUCT:** IEEE802.11n Wireless 1T1R Travel Router  
**BRAND NAME:** NETRONIX  
**MODEL NO.:** W141C  
**TEST SAMPLE:** MASS-PRODUCTION  
**TESTED:** Dec. 30, 2009 to Jan. 13, 2010  
**APPLICANT:** NETRONIX , INC.  
**STANDARDS:** FCC Part 15, Subpart C (Section 15.247),  
ANSI C63.4-2003

The above equipment (Model: W141C) has been tested by **Bureau Veritas Consumer Products Services (H.K.) Ltd., Taoyuan Branch**, and found compliance with the requirement of the above standards. The test record, data evaluation & Equipment Under Test (EUT) configurations represented herein are true and accurate accounts of the measurements of the sample's EMC characteristics under the conditions specified in this report.

**PREPARED BY :** Carol Liao , **DATE:** Jan 19, 2010  
( Carol Liao, Specialist )

**TECHNICAL ACCEPTANCE :** Hank Chung , **DATE:** Jan 19, 2010  
( Hank Chung, Deputy Manager )

**APPROVED BY :** May Chen , **DATE:** Jan 19, 2010  
( May Chen, Deputy Manager )



A D T

## 2. SUMMARY OF TEST RESULTS

The EUT has been tested according to the following specifications:

For 802.11b & g, 2412~2462MHz Band

APPLIED STANDARD: FCC Part 15, Subpart C (Section 15.247)			
Standard Section	Test Type and Limit	Result	Remark
15.207	AC Power Conducted Emission	PASS	Meet the requirement of limit. Minimum passing margin is -6.76dB at 0.541MHz
15.247(a)(2)	Spectrum Bandwidth of a Direct Sequence Spread Spectrum System Limit: min. 500kHz	PASS	Meet the requirement of limit.
15.247(b)	Maximum Peak Output Power Limit: max. 30dBm	PASS	Meet the requirement of limit.
15.247(d)	Radiated Emissions Limit: Table 15.209	PASS	Meet the requirement of limit. Minimum passing margin is -1.0dB at 4874.00MHz
15.247(e)	Power Spectral Density Limit: max. 8dBm	PASS	Meet the requirement of limit.
15.247(d)	Conducted Out-Band Emission Measurement Limit: 20dB less than the peak value of fundamental frequency	PASS	Meet the requirement of limit.
15.203	Antenna Requirement	PASS	No antenna connector is used.

## 2.1 MEASUREMENT UNCERTAINTY

Where relevant, the following measurement uncertainty levels have been estimated for tests performed on the EUT as specified in CISPR 16-4-2:

This uncertainty represents an expanded uncertainty expressed at approximately the 95% confidence level using a coverage factor of  $k=2$ .

Measurement	Value
Conducted emissions	2.45 dB
Radiated emissions (30MHz-1GHz)	3.94 dB
Radiated emissions (1GHz-18GHz)	2.49 dB
Radiated emissions (18GHz-40GHz)	2.70 dB



A D T

### 3. GENERAL INFORMATION

#### 3.1 GENERAL DESCRIPTION OF EUT

<b>PRODUCT</b>	IEEE802.11n Wireless 1T1R Travel Router
<b>MODEL NO.</b>	W141C
<b>FCC ID</b>	NOI-W141C
<b>POWER SUPPLY</b>	DC 5V from power adapter or DC 5V from host equipment via USB cable
<b>MODULATION TYPE</b>	CCK, DQPSK, DBPSK for DSSS 64QAM, 16QAM, QPSK, BPSK for OFDM
<b>MODULATION TECHNOLOGY</b>	DSSS, OFDM
<b>TRANSFER RATE</b>	802.11b: 11 / 5.5 / 2 / 1Mbps 802.11g: 54 / 48 / 36 / 24 / 18 / 12 / 9 / 6Mbps 802.11n (20MHz, 800ns GI): 65 / 58.5 / 52 / 39 / 26 / 19.5 / 13 / 6.5Mbps 802.11n (40MHz, 800ns GI): 135 / 121.5 / 108 / 81 / 54 / 40.5 / 27 / 13.5Mbps 802.11n (20MHz, 400ns GI): 72.2 / 65 / 57.8 / 43.3 / 28.9 / 21.7 / 14.4 / 7.2Mbps 802.11n (40MHz, 400ns GI): 150 / 135 / 120 / 90 / 60 / 45 / 30 / 15Mbps
<b>OPERATING FREQUENCY</b>	2412 ~ 2462MHz
<b>NUMBER OF CHANNEL</b>	11 for 802.11b, 802.11g, 802.11n (20MHz) 7 for 802.11n (40MHz)
<b>MAXIMUM OUTPUT POWER</b>	802.11b: 107.2mW 802.11g: 251.2mW 802.11n (20MHz): 251.2mW 802.11n (40MHz): 177.8mW
<b>ANTENNA TYPE</b>	PCB printed antenna with -3.55 dBi antenna gain
<b>ANTENNA CONNECTOR</b>	NA
<b>DATA CABLE</b>	USB Cable x 1 (Shielded, 0.63m)
<b>I/O PORTS</b>	LAN port x 1, WAN port x 1, USB port x 1
<b>ASSOCIATED DEVICES</b>	Adapter x 1

**NOTE:**

1. The EUT must be supplied with a power adapter as following information:

Brand:	DVE
Model No.:	DSA-5W-05 FJP
Input power :	AC 100~240V, 0.2A, 50~60Hz
Output power :	DC 5V, 10.6A DC output cable (Unshielded, 1.78m)

2. For radiated test :The EUT was pre-tested in chamber under the following modes:

Test Mode	Description
Mode A	power adapter
<b>Mode B</b>	<b>USB Cable</b>

From the above modes, the worse case was found in Mode B. Therefore only the test data of the mode was recorded in this report.

3. The EUT incorporates a SISO function with 802.11n. Physically, the EUT provides one completed transmitter and one completed receiver.
4. The EUT is 1 \* 1 spatial SISO (1Tx & 1Rx) without beam forming function. The antenna configuration is one transmitter antenna and one receiver antenna, as there is one PCB printed antenna.
5. The EUT complies with 802.11n standards and backwards compatible with 802.11b, 802.11g products.
6. The above EUT information was declared by manufacturer and for more detailed feature descriptions, please refer to the manufacturer's specifications or user's manual.



### 3.2 DESCRIPTION OF TEST MODES

#### Operated in 2400 ~ 2483.5MHz band:

Eleven channels are provided for 802.11b, 802.11g, 802.11n (20MHz):

CHANNEL	FREQUENCY	CHANNEL	FREQUENCY
1	2412MHz	7	2442MHz
2	2417MHz	8	2447MHz
3	2422MHz	9	2452MHz
4	2427MHz	10	2457MHz
5	2432MHz	11	2462MHz
6	2437MHz		

Seven channels are provided for 802.11n (40MHz):

CHANNEL	FREQUENCY	CHANNEL	FREQUENCY
1	2422MHz	5	2442MHz
2	2427MHz	6	2447MHz
3	2432MHz	7	2452MHz
4	2437MHz		

### 3.2.1 TEST MODE APPLICABILITY AND TESTED CHANNEL DETAIL

EUT CONFIGURE MODE	APPLICABLE TO				DESCRIPTION
	PLC	RE < 1G	RE ≥ 1G	APCM	
A	√	√	√	√	EUT with USB cable
B	√	-	-	-	EUT with power adapter

Where **PLC**: Power Line Conducted Emission      **RE < 1G**: Radiated Emission below 1GHz  
**RE ≥ 1G**: Radiated Emission above 1GHz      **APCM**: Antenna Port Conducted Measurement

#### **POWER LINE CONDUCTED EMISSION TEST:**

- Pre-Scan has been conducted to determine the worst-case mode from all possible combinations between available modulations, data rates and antenna ports (if EUT with antenna diversity architecture).
- Following channel(s) was (were) selected for the final test as listed below.

MODE	AVAILABLE CHANNEL	TESTED CHANNEL	MODULATION TECHNOLOGY	MODULATION TYPE	DATA RATE (Mbps)	EUT CONFIGURE MODE
802.11g	1 to 11	1	OFDM	BPSK	6	A, B

#### **RADIATED EMISSION TEST (BELOW 1 GHz):**

- Pre-Scan has been conducted to determine the worst-case mode from all possible combinations between available modulations, data rates and antenna ports (if EUT with antenna diversity architecture).
- Following channel(s) was (were) selected for the final test as listed below.

MODE	AVAILABLE CHANNEL	TESTED CHANNEL	MODULATION TECHNOLOGY	MODULATION TYPE	DATA RATE (Mbps)	EUT CONFIGURE MODE
802.11g	1 to 11	6	OFDM	BPSK	6	A, B



A D T

**RADIATED EMISSION TEST (ABOVE 1 GHz):**

- Pre-Scan has been conducted to determine the worst-case mode from all possible combinations between available modulations, data rates and antenna ports (if EUT with antenna diversity architecture).
- Following channel(s) was (were) selected for the final test as listed below.

MODE	AVAILABLE CHANNEL	TESTED CHANNEL	MODULATION TECHNOLOGY	MODULATION TYPE	DATA RATE (Mbps)	EUT CONFIGURE MODE
802.11b	1 to 11	1, 6, 11	DSSS	DBPSK	1	A
802.11g	1 to 11	1, 6, 11	OFDM	BPSK	6	A
802.11n (20MHz)	1 to 11	1, 6, 11	OFDM	BPSK	6.5	A
802.11n (40MHz)	1 to 7	1, 4, 7	OFDM	BPSK	13.5	A

**CONDUCTED OUT-BAND EMISSION MEASUREMENT:**

- Pre-Scan has been conducted to determine the worst-case mode from all possible combinations between available modulations, data rates and antenna ports (if EUT with antenna diversity architecture).
- Following channel(s) was (were) selected for the final test as listed below.

MODE	AVAILABLE CHANNEL	TESTED CHANNEL	MODULATION TECHNOLOGY	MODULATION TYPE	DATA RATE (Mbps)	EUT CONFIGURE MODE
802.11b	1 to 11	1, 11	DSSS	DBPSK	1	A
802.11g	1 to 11	1, 11	OFDM	BPSK	6	A
802.11n (20MHz)	1 to 11	1, 11	OFDM	BPSK	6.5	A
802.11n (40MHz)	1 to 7	1, 7	OFDM	BPSK	13.5	A



A D T

### **ANTENNA PORT CONDUCTED MEASUREMENT:**

- This item includes all test value of each mode, but only includes spectrum plot of worst value of each mode.
- Pre-Scan has been conducted to determine the worst-case mode from all possible combinations between available modulations, data rates and antenna ports (if EUT with antenna diversity architecture).
- Following channel(s) was (were) selected for the final test as listed below.

MODE	AVAILABLE CHANNEL	TESTED CHANNEL	MODULATION TECHNOLOGY	MODULATION TYPE	DATA RATE (Mbps)	EUT CONFIGURE MODE
802.11b	1 to 11	1, 6, 11	DSSS	DBPSK	1	A
802.11g	1 to 11	1, 6, 11	OFDM	BPSK	6	A
802.11n (20MHz)	1 to 11	1, 6, 11	OFDM	BPSK	6.5	A
802.11n (40MHz)	1 to 7	1, 4, 7	OFDM	BPSK	13.5	A

### **TEST CONDITION:**

APPLICABLE TO	ENVIRONMENTAL CONDITIONS	INPUT POWER	TESTED BY
RE <sup>3</sup> 1G	15deg. C, 68%RH, 1022 hPa	120Vac, 60Hz	Duke Tseng
RE<1G	14deg. C, 70%RH, 1022 hPa	120Vac, 60Hz	Frank Liu
PLC	22deg. C, 62%RH, 1022 hPa	120Vac, 60Hz	Leo Peng
APCM	20deg. C, 60%RH, 1022 hPa	120Vac, 60Hz	Kent Liu

### 3.3 GENERAL DESCRIPTION OF APPLIED STANDARDS

The EUT is an IEEE802.11n Wireless 1T1R Travel Router. According to the specifications of the manufacturer, it must comply with the requirements of the following standards:

#### **FCC Part 15, Subpart C. (15.247)**

#### **ANSI C63.4-2003**

All test items have been performed and recorded as per the above standards.

**NOTE:** The EUT is also considered as a kind of computer peripheral, because the connection to computer is necessary for typical use. It has been verified to comply with the requirements of FCC Part 15, Subpart B, Class B (DoC). The test report has been issued separately.



A D T

### 3.4 DESCRIPTION OF SUPPORT UNITS

The EUT has been tested as an independent unit together with other necessary accessories or support units. The following support units or accessories were used to form a representative test configuration during the tests.

NO.	PRODUCT	BRAND	MODEL NO.	SERIAL NO.	FCC ID
1	NOTEBOOK COMPUTER	DELL	PP18L	6976685584	FCC DoC
2	NOTEBOOK COMPUTER	DELL	PP17L	CN-ONF743-48643-7AV-0124	FCC DoC
3	NOTEBOOK COMPUTER	DELL	PP21L	CN-0GD366-70166-5B3-09ZX	QDS-BRCM1016
4	NOTEBOOK COMPUTER	DELL	D531	CN-0XM006-48643-86L-4472	QDS-BRCM1019
5	iPod nano 2GB	APPLE	A1199	YM712NHUVQ5	FCC DoC

NO.	SIGNAL CABLE DESCRIPTION OF THE ABOVE SUPPORT UNITS
1	UTP Cable (10m)
2	UTP Cable (10m)
3	NA
4	USB Cable (0.63m)
5	1 m shielded cable, terminated with USB connector, w/o core.

**NOTE:** All power cords of the above support units are non shielded (1.8m).

### 3.5 CONFIGURATION OF SYSTEM UNDER TEST

For power adapter Mode:

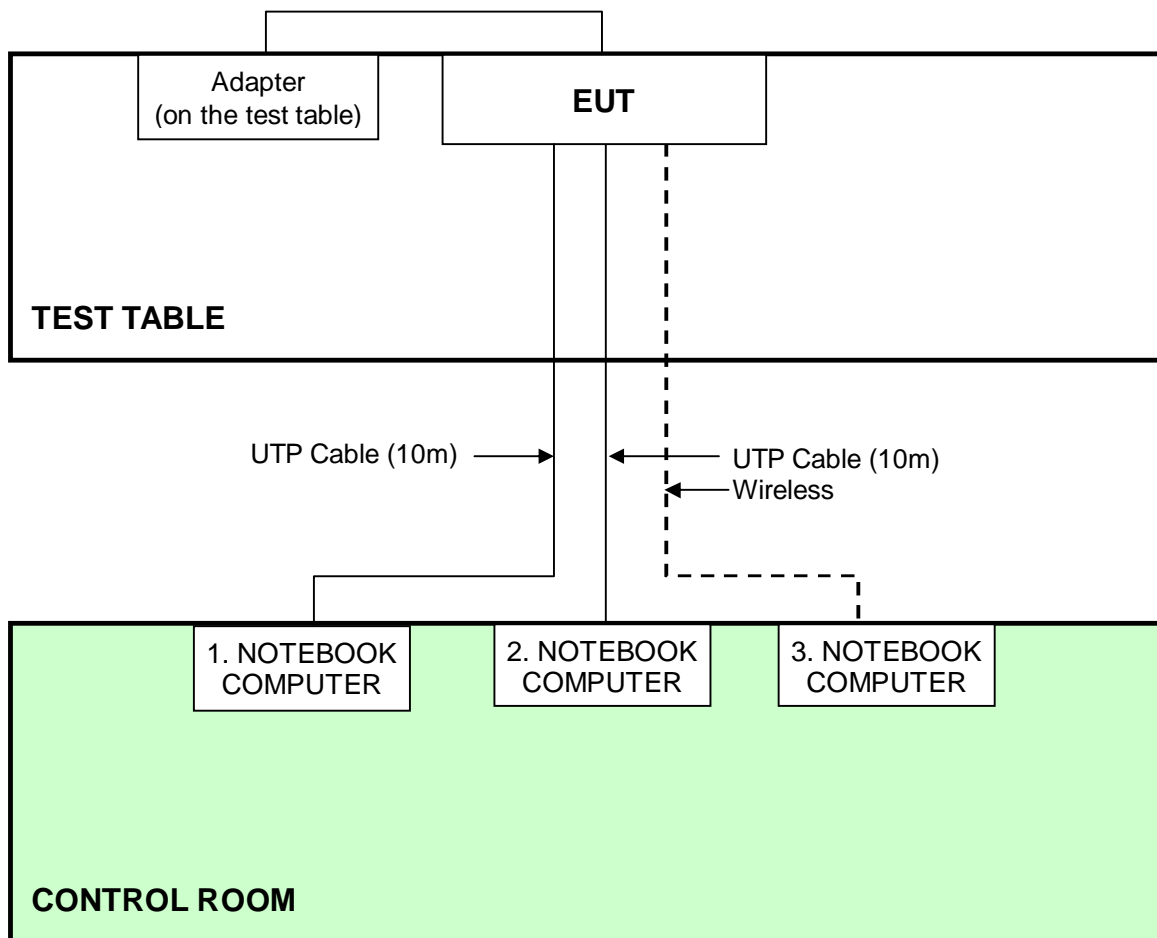

**For USB cable Mode – Conducted Emission test:**

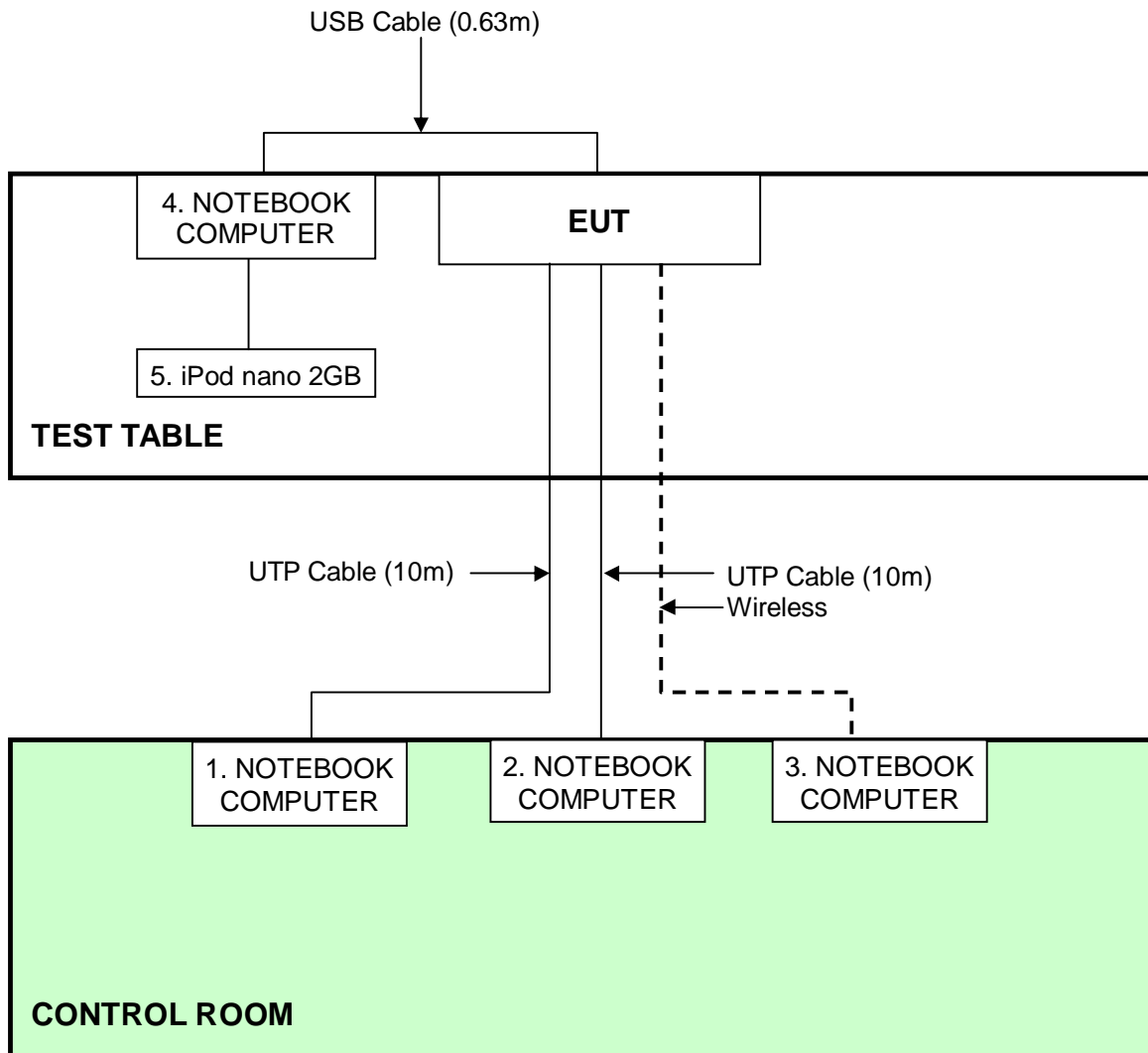



**For USB cable Mode – other test items:**

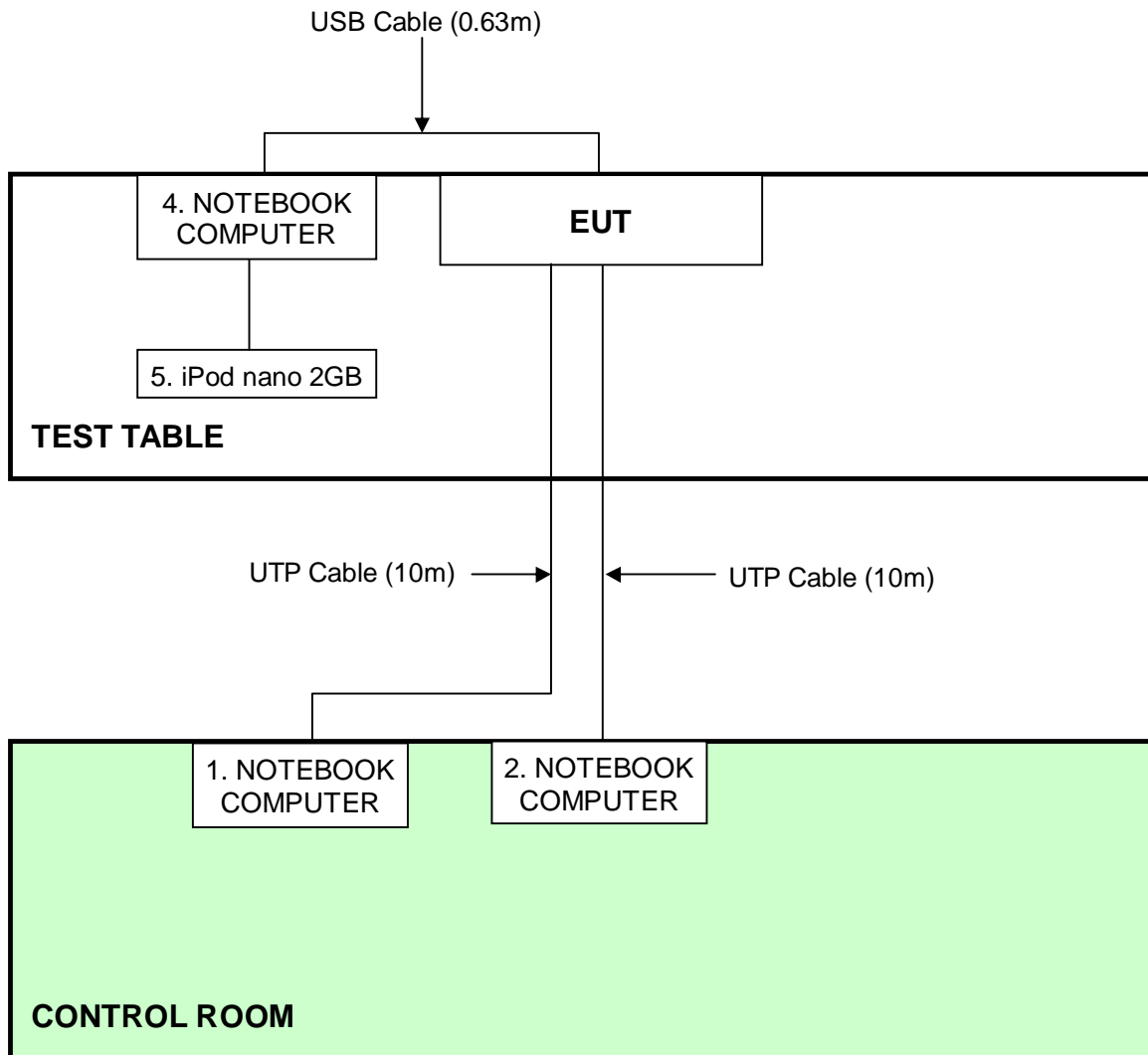



A D T

## 4. TEST TYPES AND RESULTS

### 4.1 CONDUCTED EMISSION MEASUREMENT

#### 4.1.1 LIMITS OF CONDUCTED EMISSION MEASUREMENT

FREQUENCY OF EMISSION (MHz)	CONDUCTED LIMIT (dBµV)	
0.15-0.5	Quasi-peak	Average
0.5-5	66 to 56	56 to 46
5-30	56	46
	60	50

- NOTE:**
1. The lower limit shall apply at the transition frequencies.
  2. The limit decreases in line with the logarithm of the frequency in the range of 0.15 to 0.50 MHz.
  3. All emanations from a class A/B digital device or system, including any network of conductors and apparatus connected thereto, shall not exceed the level of field strengths specified above.

#### 4.1.2 TEST INSTRUMENTS

DESCRIPTION & MANUFACTURER	MODEL NO.	SERIAL NO.	CALIBRATED DATE	CALIBRATED UNTIL
ROHDE & SCHWARZ Test Receiver	ESCS 30	100287	Mar. 05, 2009	Mar. 04, 2010
Line-Impedance Stabilization Network (for EUT)	NSLK 8127	8127-523	Sep 23,2009	Sep 22, 2010
Line-Impedance Stabilization Network (for Peripheral)	KNW-407	8-1395-12	May 04, 2009	May 03, 2010
RF Cable (JYBAO)	5DFB	COACAB-001	Dec 14, 2009	Dec 13, 2010
50 ohms Terminator	50	3	Oct. 28, 2009	Oct. 27, 2010
Software	BV ADT_Cond_V7.3.7	NA	NA	NA

**Note:**

1. The calibration interval of the above test instruments is 12 months and the calibrations are traceable to NML/ROC and NIST/USA.
2. The test was performed in Shielded Room No. A.
3. The VCCI Con A Registration No. is C-817.

#### 4.1.3 TEST PROCEDURES

- a. The EUT was placed 0.4 meters from the conducting wall of the shielded room with EUT being connected to the power mains through a line impedance stabilization network (LISN). Other support units were connected to the power mains through another LISN. The two LISNs provide 50 ohm/ 50uH of coupling impedance for the measuring instrument.
- b. Both lines of the power mains connected to the EUT were checked for maximum conducted interference.
- c. The frequency range from W241kHz to 30MHz was searched. Emission levels under (Limit - 20dB) were not recorded.

#### 4.1.4 DEVIATION FROM TEST STANDARD

No deviation

#### 4.1.5 TEST SETUP

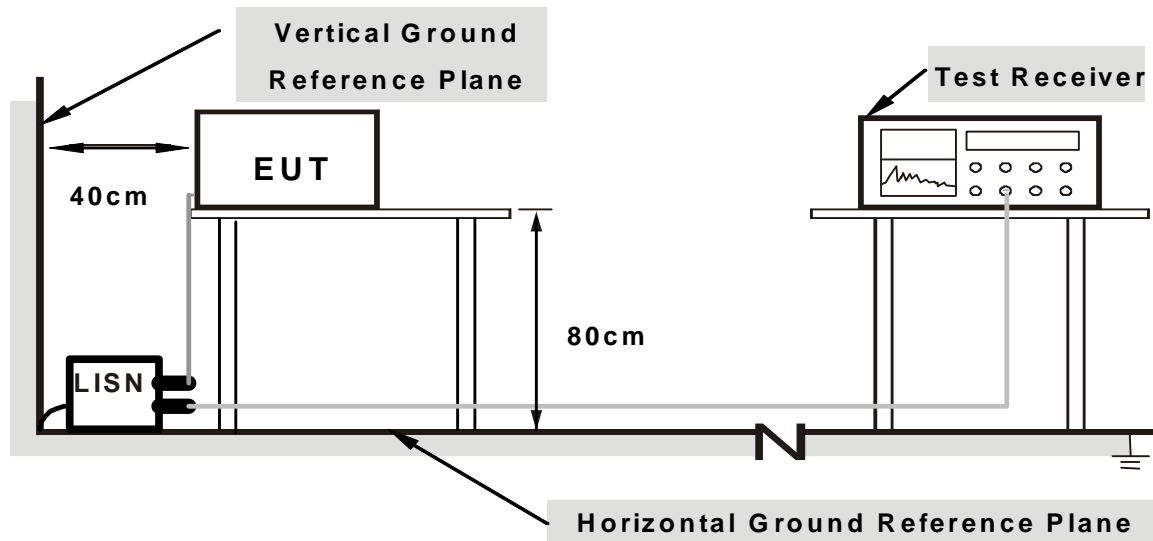

**Note: 1. Support units were connected to second LISN.**

**2. Both of LISNs (AMN) are 80 cm from EUT and at least 80 from other units and other metal planes**

For the actual test configuration, please refer to the related item – Photographs of the Test Configuration.

#### 4.1.6 EUT OPERATING CONDITIONS

1. Placed the EUT on testing table.
2. Prepared other computer systems (support units 1 ~ 3) to act as communication partners and placed them outside of testing area.
3. The communication partners run test program “Ping.exe” to enable EUT under transmission/receiving condition continuously at specific channel frequency.

### 4.1.7 TEST RESULTS

#### 802.11g OFDM MODULATION: with USB Mode

PHASE	Line (L)	6dB BANDWIDTH	9 kHz
-------	----------	---------------	-------

No	Freq. [MHz]	Corr. Factor (dB)	Reading Value		Emission Level		Limit		Margin	
			[dB (uV)]		[dB (uV)]		[dB (uV)]		(dB)	
			Q.P.	AV.	Q.P.	AV.	Q.P.	AV.	Q.P.	AV.
1	0.173	0.04	51.79	-	51.83	-	64.79	54.79	-12.96	-
2	0.228	0.04	46.66	-	46.70	-	62.52	52.52	-15.82	-
3	1.887	0.12	40.15	-	40.27	-	56.00	46.00	-15.73	-
4	3.655	0.19	46.56	32.49	46.75	32.68	56.00	46.00	-9.25	-13.32
5	3.771	0.19	47.62	33.32	47.81	33.51	56.00	46.00	-8.19	-12.49
6	4.170	0.20	45.21	-	45.41	-	56.00	46.00	-10.59	-

- REMARKS:**
1. Q.P. and AV. are abbreviations of quasi-peak and average individually.
  2. "-": The Quasi-peak reading value also meets average limit and measurement with the average detector is unnecessary.
  3. The emission levels of other frequencies were very low against the limit.
  4. Margin value = Emission level - Limit value
  5. Correction factor = Insertion loss + Cable loss
  6. Emission Level = Correction Factor + Reading Value.

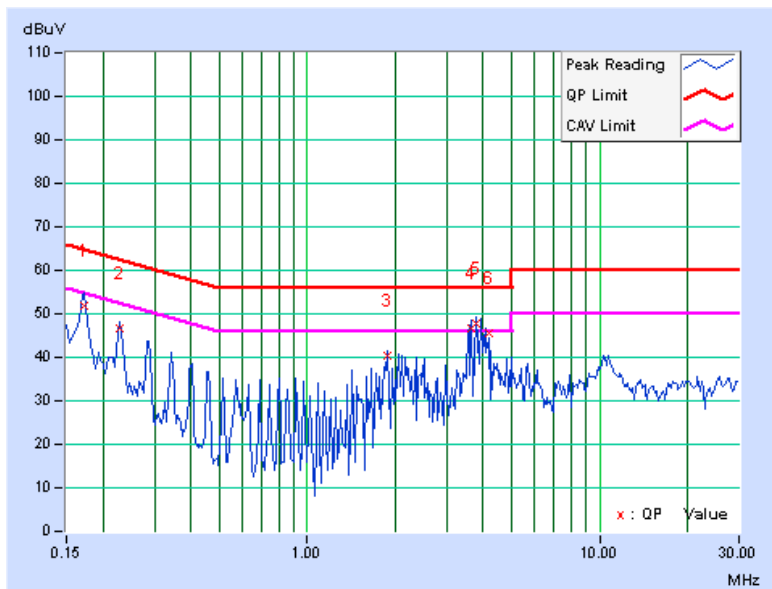

<b>PHASE</b>	Neutral (N)	<b>6dB BANDWIDTH</b>	9 kHz
--------------	-------------	----------------------	-------

No	Freq. [MHz]	Corr. Factor (dB)	Reading Value [dB (uV)]		Emission Level [dB (uV)]		Limit [dB (uV)]		Margin (dB)	
			Q.P.	AV.	Q.P.	AV.	Q.P.	AV.	Q.P.	AV.
	1	0.173	0.05	51.01	-	51.06	-	64.83	54.83	-13.77
2	0.287	0.06	40.85	-	40.91	-	60.62	50.62	-19.71	-
3	1.770	0.12	38.81	-	38.93	-	56.00	46.00	-17.07	-
4	2.055	0.13	40.21	-	40.34	-	56.00	46.00	-15.66	-
5	3.769	0.21	44.24	-	44.45	-	56.00	46.00	-11.55	-
6	4.109	0.22	42.36	-	42.58	-	56.00	46.00	-13.42	-

- REMARKS:**
1. Q.P. and AV. are abbreviations of quasi-peak and average individually.
  2. "-": The Quasi-peak reading value also meets average limit and measurement with the average detector is unnecessary.
  3. The emission levels of other frequencies were very low against the limit.
  4. Margin value = Emission level - Limit value
  5. Correction factor = Insertion loss + Cable loss
  6. Emission Level = Correction Factor + Reading Value.

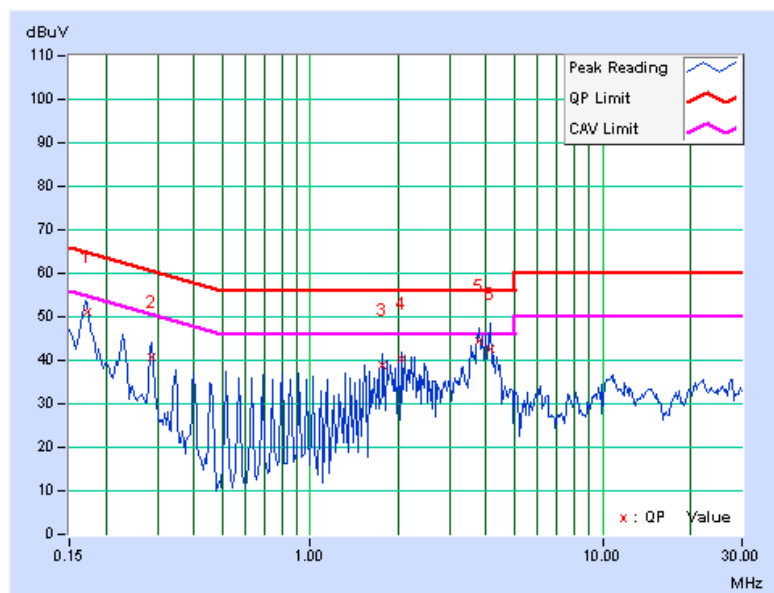

**802.11g OFDM MODULATION: with power adapter Mode**

<b>PHASE</b>	Line (L)	<b>6dB BANDWIDTH</b>	9 kHz
--------------	----------	----------------------	-------

No	Freq. [MHz]	Corr. Factor (dB)	Reading Value [dB (uV)]		Emission Level [dB (uV)]		Limit [dB (uV)]		Margin (dB)	
			Q.P.	AV.	Q.P.	AV.	Q.P.	AV.	Q.P.	AV.
			1	0.232	0.04	48.58	-	48.62	-	62.38
2	0.427	0.06	47.36	37.34	47.42	37.40	57.30	47.30	-9.88	-9.90
<b>3</b>	<b>0.541</b>	<b>0.07</b>	<b>49.17</b>	<b>37.80</b>	<b>49.24</b>	<b>37.87</b>	<b>56.00</b>	<b>46.00</b>	<b>-6.76</b>	<b>-8.13</b>
4	0.728	0.08	46.50	35.08	46.58	35.16	56.00	46.00	-9.42	-10.84
5	0.841	0.08	44.31	-	44.39	-	56.00	46.00	-11.61	-
6	1.141	0.09	43.32	-	43.41	-	56.00	46.00	-12.59	-
7	1.563	0.11	43.73	-	43.84	-	56.00	46.00	-12.16	-

- REMARKS:**
1. Q.P. and AV. are abbreviations of quasi-peak and average individually.
  2. "-": The Quasi-peak reading value also meets average limit and measurement with the average detector is unnecessary.
  3. The emission levels of other frequencies were very low against the limit.
  4. Margin value = Emission level - Limit value
  5. Correction factor = Insertion loss + Cable loss
  6. Emission Level = Correction Factor + Reading Value.

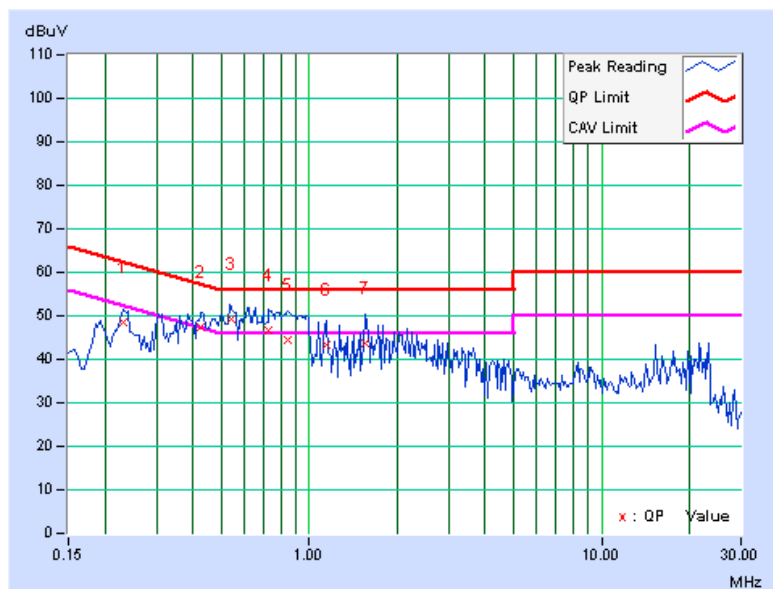

<b>PHASE</b>	Neutral (N)	<b>6dB BANDWIDTH</b>	9 kHz
--------------	-------------	----------------------	-------

No	Freq. [MHz]	Corr. Factor (dB)	Reading Value [dB (uV)]		Emission Level [dB (uV)]		Limit [dB (uV)]		Margin (dB)	
			Q.P.	AV.	Q.P.	AV.	Q.P.	AV.	Q.P.	AV.
	1	0.240	0.05	48.44	-	48.49	-	62.10	52.10	-13.61
2	0.318	0.06	45.43	-	45.49	-	59.76	49.76	-14.27	-
3	0.380	0.07	42.96	-	43.03	-	58.27	48.27	-15.24	-
4	0.447	0.07	44.00	-	44.07	-	56.93	46.93	-12.86	-
5	0.560	0.08	46.64	34.92	46.72	35.00	56.00	46.00	-9.28	-11.00
6	0.677	0.08	46.79	35.45	46.87	35.53	56.00	46.00	-9.13	-10.47
7	0.810	0.09	44.15	-	44.24	-	56.00	46.00	-11.76	-
8	0.951	0.10	42.34	-	42.44	-	56.00	46.00	-13.56	-
9	1.570	0.12	42.27	-	42.39	-	56.00	46.00	-13.61	-

- REMARKS:**
1. Q.P. and AV. are abbreviations of quasi-peak and average individually.
  2. "-": The Quasi-peak reading value also meets average limit and measurement with the average detector is unnecessary.
  3. The emission levels of other frequencies were very low against the limit.
  4. Margin value = Emission level - Limit value
  5. Correction factor = Insertion loss + Cable loss
  6. Emission Level = Correction Factor + Reading Value.

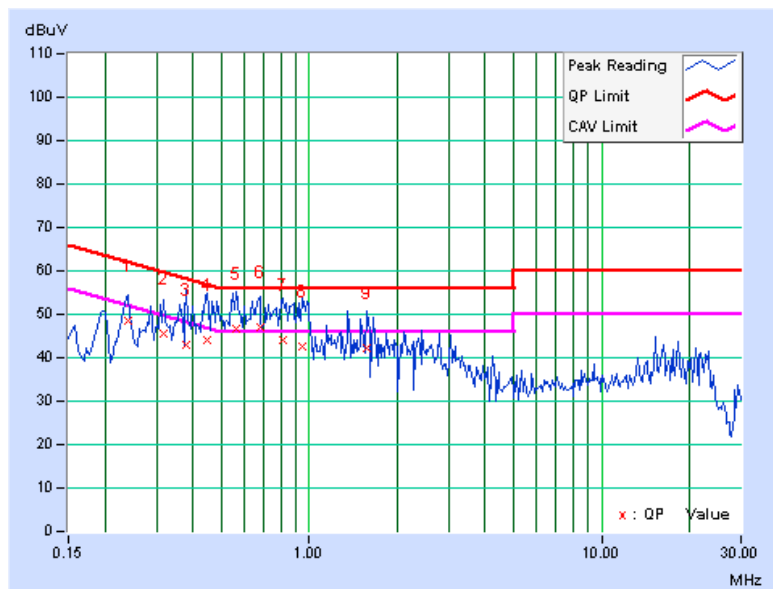



## 4.2 RADIATED EMISSION MEASUREMENT

### 4.2.1 LIMITS OF RADIATED EMISSION MEASUREMENT

Emissions radiated outside of the specified bands, shall be according to the general radiated limits in 15.209 as following:

Frequencies (MHz)	Field strength (microvolts/meter)	Measurement distance (meters)
0.009-0.490	2400/F(kHz)	300
0.490-1.705	24000/F(kHz)	30
1.705-30.0	30	30
30-88	100	3
88-216	W241	3
216-960	200	3
Above 960	500	3

**NOTE:**

1. The lower limit shall apply at the transition frequencies.
2. Emission level (dBuV/m) = 20 log Emission level (uV/m).
3. As shown in 15.35(b), for frequencies above 1000MHz, the field strength limits are based on average detector, however, the peak field strength of any emission shall not exceed the maximum permitted average limits, specified above by more than 20dB under any condition of modulation.



A D T

#### 4.2.2 TEST INSTRUMENTS

DESCRIPTION & MANUFACTURER	MODEL NO.	SERIAL NO.	CALIBRATED DATE	CALIBRATED UNTIL
ROHDE & SCHWARZ Spectrum Analyzer	FSP40	100036	Dec. 18, 2009	Dec. 17, 2010
Agilent PSA Spectrum Analyzer	E4446A	MY46180622	Apr. 24 , 2009	Apr. 23 , 2010
HP Pre_Amplifier	8449B	300801923	Nov. 02, 2009	Nov. 01, 2010
ROHDE & SCHWARZ Test Receiver	ESCS30	847124/029	Aug. 28, 2009	Aug. 27, 2010
SCHWARZBECK TRILOG Broadband Antenna	VULB 9168	138	April 29, 2009	April 28, 2010
Schwarzbeck Horn_Antenna	BBHA9120	D124	Dec. 18, 2009	Dec. 17, 2010
Schwarzbeck Horn_Antenna	BBHA 9170	BBHA9170153	Jan. 22, 2009	Jan. 21, 2010
R&S Loop Antenna	HFH2-Z2	100070	Jan. 14, 2009	Jan. 13, 2010
RF Switches	EMH-011	1001	NA	NA
RF CABLE (Chaintek)	Sucoflex 106	28077	Aug. 14, 2009	Aug. 13, 2010
RF Cable	8DFB	STCCAB-30M-1GHz	NA	NA
Software	ADT_Radiated_V7.6.15.9.2	NA	NA	NA
CT Antenna Tower & Turn Table	NA	NA	NA	NA

Note: 1. The calibration interval of the above test instruments is 12 months and the calibrations are traceable to NML/ROC and NIST/USA.

2. The horn antenna, HP preamplifier (model: 8449B) and Spectrum Analyzer (model: FSP40) are used only for the measurement of emission frequency above 1GHz if tested.

3. The test was performed in Open Site No. C.

4. The FCC Site Registration No. is 656396.

5. The VCCI Site Registration No. is R-1626.

6. The CANADA Site Registration No. is IC 7450G-3.

### 4.2.3 TEST PROCEDURES

- a. The EUT was placed on the top of a rotating table 0.8 meters above the ground at a 10 meter open area test site. The table was rotated 360 degrees to determine the position of the highest radiation.
- b. The EUT was set 3 meters away from the interference-receiving antenna, which was mounted on the top of a variable-height antenna tower.
- c. The antenna is a broadband antenna, and its height is varied from one meter to four meters above the ground to determine the maximum value of the field strength. Both horizontal and vertical polarizations of the antenna are set to make the measurement.
- d. For each suspected emission, the EUT was arranged to its worst case and then the antenna was tuned to heights from 1 meter to 4 meters and the rotatable table was turned from 0 degrees to 360 degrees to find the maximum reading.
- e. The test-receiver system was set to Peak Detect Function and Specified Bandwidth with Maximum Hold Mode.
- f. If the emission level of the EUT in peak mode was 10dB lower than the limit specified, then testing could be stopped and the peak values of the EUT would be reported. Otherwise the emissions that did not have 10dB margin would be re-tested one by one using peak, quasi-peak or average method as specified and then reported in a data sheet.

**NOTE:**

1. The resolution bandwidth and video bandwidth of test receiver/spectrum analyzer is 120kHz for Peak detection (PK) and Quasi-peak detection (QP) at frequency below 1GHz.
2. The resolution bandwidth of test receiver/spectrum analyzer is 1 MHz and the video bandwidth is 3 MHz for Peak detection (PK) at frequency above 1GHz.
3. The resolution bandwidth of test receiver/spectrum analyzer is 1 MHz and the video bandwidth is 10 Hz for Average detection (AV) at frequency above 1GHz.

### 4.2.4 DEVIATION FROM TEST STANDARD

No deviation

#### 4.2.5 TEST SETUP

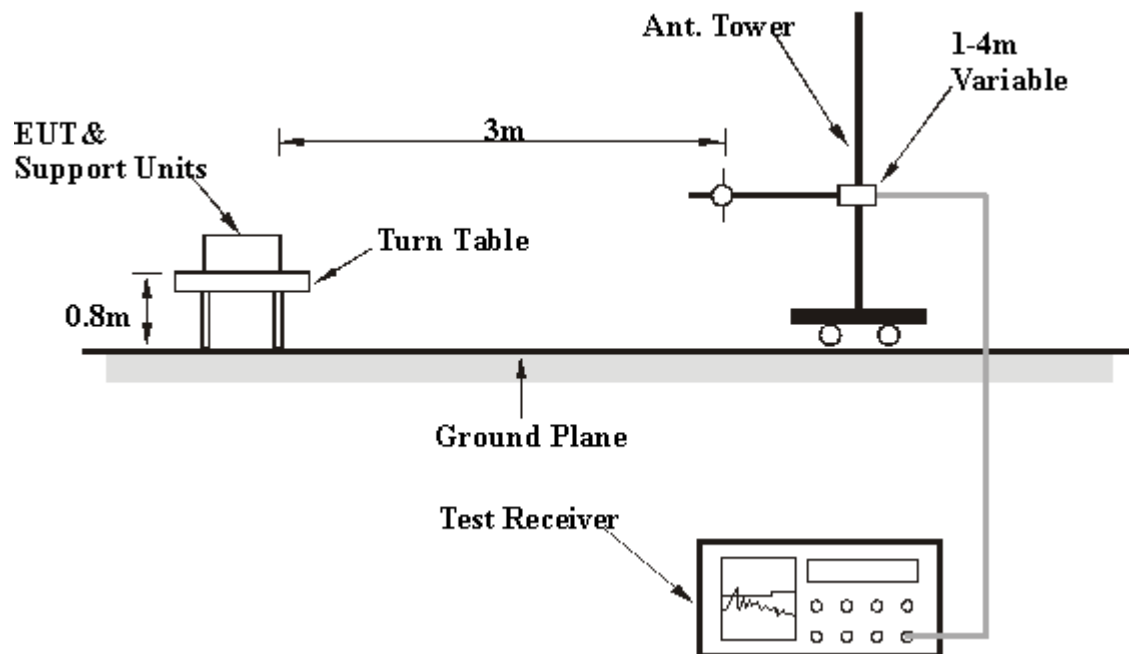

For the actual test configuration, please refer to the related item – Photographs of the Test Configuration.

#### 4.2.6 EUT OPERATING CONDITIONS

1. Placed the EUT on testing table.
2. Prepared other computer systems (support units 1 ~ 2) to act as communication partners and placed them outside of testing area.
3. The communication partners run test program “8196B v3.4 MP” to enable EUT under transmission/receiving condition continuously at specific channel frequency.



A D T

## 4.2.7 TEST RESULTS

## BELOW 1GHz WORST-CASE DATA : 802.11g OFDM MODULATION

EUT TEST CONDITION		MEASUREMENT DETAIL	
CHANNEL	Channel 1	FREQUENCY RANGE	Below 1000MHz
INPUT POWER (SYSTEM)	120Vac, 60 Hz	DETECTOR FUNCTION	Quasi-Peak
ENVIRONMENTAL CONDITIONS	14deg. C, 70%RH 1022 hPa	TESTED BY	Frank Liu

ANTENNA POLARITY & TEST DISTANCE: HORIZONTAL AT 3 M								
NO.	FREQ. (MHz)	EMISSION LEVEL (dBuV/m)	LIMIT (dBuV/m)	MARGIN (dB)	ANTENNA HEIGHT (m)	TABLE ANGLE (Degree)	RAW VALUE (dBuV)	CORRECTION FACTOR (dB/m)
1	114.42	18.2 QP	43.5	-25.3	1.04 H	66	6.86	11.38
2	240.00	31.2 QP	46.0	-14.8	1.09 H	27	17.89	13.33
3	360.00	32.3 QP	46.0	-13.7	1.14 H	68	14.75	17.52
4	480.00	43.1 QP	46.0	-2.9	1.62 H	159	22.36	20.74
5	839.99	43.0 QP	46.0	-3.0	1.04 H	211	15.78	27.21
6	960.00	33.2 QP	46.0	-12.8	1.07 H	284	4.56	28.68
ANTENNA POLARITY & TEST DISTANCE: VERTICAL AT 3 M								
NO.	FREQ. (MHz)	EMISSION LEVEL (dBuV/m)	LIMIT (dBuV/m)	MARGIN (dB)	ANTENNA HEIGHT (m)	TABLE ANGLE (Degree)	RAW VALUE (dBuV)	CORRECTION FACTOR (dB/m)
1	69.25	34.5 QP	40.0	-5.5	1.00 V	178	21.61	12.89
2	244.08	26.9 QP	46.0	-19.1	1.00 V	265	13.39	13.48
3	297.00	32.2 QP	46.0	-13.8	1.39 V	149	16.37	15.87
4	366.00	29.6 QP	46.0	-16.4	1.39 V	253	11.92	17.67
5	445.50	31.8 QP	46.0	-14.2	1.39 V	194	12.02	19.77
6	488.00	40.8 QP	46.0	-5.2	1.39 V	0	19.83	20.97
7	742.52	35.2 QP	46.0	-10.8	1.07 V	123	9.64	25.59
8	960.00	31.6 QP	46.0	-14.4	1.08 V	127	2.93	28.68

- REMARKS:**
1. Emission level (dBuV/m) = Raw Value (dBuV) + Correction Factor (dB/m).
  2. Correction Factor (dB/m) = Antenna Factor (dB/m) + Cable Factor (dB).
  3. The other emission levels were very low against the limit.
  4. Margin value = Emission level – Limit value.



A D T

### ABOVE 1GHz WORST-CASE DATA

#### 802.11b DSSS MODULATION

EUT TEST CONDITION		MEASUREMENT DETAIL	
CHANNEL	Channel 1	FREQUENCY RANGE	1 ~ 25GHz
INPUT POWER (SYSTEM)	120Vac, 60 Hz	DETECTOR FUNCTION	Peak (PK) Average (AV)
ENVIRONMENTAL CONDITIONS	15deg. C, 68%RH 1022 hPa	TESTED BY	Duke Tseng

ANTENNA POLARITY & TEST DISTANCE: HORIZONTAL AT 3 M								
NO.	FREQ. (MHz)	EMISSION LEVEL (dBuV/m)	LIMIT (dBuV/m)	MARGIN (dB)	ANTENNA HEIGHT (m)	TABLE ANGLE (Degree)	RAW VALUE (dBuV)	CORRECTION FACTOR (dB/m)
1	2386.27	61.5 PK	74.0	-12.5	1.36 H	342	31.21	30.27
2	2386.27	46.0 AV	54.0	-8.0	1.36 H	342	15.69	30.27
3	*2412.00	102.2 PK			1.36 H	342	71.79	30.36
4	*2412.00	99.5 AV			1.36 H	342	69.17	30.36
5	4824.00	53.4 PK	74.0	-20.6	1.60 H	342	16.65	36.79
6	4824.00	50.0 AV	54.0	-4.0	1.60 H	342	13.19	36.79
ANTENNA POLARITY & TEST DISTANCE: VERTICAL AT 3 M								
NO.	FREQ. (MHz)	EMISSION LEVEL (dBuV/m)	LIMIT (dBuV/m)	MARGIN (dB)	ANTENNA HEIGHT (m)	TABLE ANGLE (Degree)	RAW VALUE (dBuV)	CORRECTION FACTOR (dB/m)
1	2385.87	61.4 PK	74.0	-12.6	2.05 V	257	31.11	30.27
2	2385.87	43.8 AV	54.0	-10.2	2.05 V	257	13.55	30.27
3	*2412.00	98.9 PK			2.05 V	256	68.54	30.36
4	*2412.00	96.1 AV			2.05 V	256	65.69	30.36
5	4824.00	54.9 PK	74.0	-19.1	1.40 V	99	18.14	36.79
6	4824.00	52.2 AV	54.0	-1.8	1.40 V	99	15.42	36.79

- REMARKS:**
1. Emission level (dBuV/m) = Raw Value (dBuV) + Correction Factor (dB/m).
  2. Correction Factor (dB/m) = Antenna Factor (dB/m) + Cable Factor (dB).
  3. The other emission levels were very low against the limit.
  4. Margin value = Emission level – Limit value.
  5. “ \* “: Fundamental frequency.



A D T

EUT TEST CONDITION		MEASUREMENT DETAIL	
CHANNEL	Channel 6	FREQUENCY RANGE	1 ~ 25GHz
INPUT POWER (SYSTEM)	120Vac, 60 Hz	DETECTOR FUNCTION	Peak (PK) Average (AV)
ENVIRONMENTAL CONDITIONS	15deg. C, 68%RH 1022 hPa	TESTED BY	Duke Tseng

ANTENNA POLARITY & TEST DISTANCE: HORIZONTAL AT 3 M								
NO.	FREQ. (MHz)	EMISSION LEVEL (dBuV/m)	LIMIT (dBuV/m)	MARGIN (dB)	ANTENNA HEIGHT (m)	TABLE ANGLE (Degree)	RAW VALUE (dBuV)	CORRECTION FACTOR (dB/m)
1	*2437.00	102.2 PK			1.37 H	344	71.74	30.46
2	*2437.00	99.4 AV			1.37 H	344	68.94	30.46
3	4874.00	52.0 PK	74.0	-22.0	1.53 H	26	15.06	36.92
4	4874.00	47.4 AV	54.0	-6.6	1.53 H	26	10.45	36.92
5	7311.00	52.2 PK	74.0	-21.8	1.30 H	97	9.03	43.14
6	7311.00	38.6 AV	54.0	-15.4	1.30 H	97	-4.58	43.14
ANTENNA POLARITY & TEST DISTANCE: VERTICAL AT 3 M								
NO.	FREQ. (MHz)	EMISSION LEVEL (dBuV/m)	LIMIT (dBuV/m)	MARGIN (dB)	ANTENNA HEIGHT (m)	TABLE ANGLE (Degree)	RAW VALUE (dBuV)	CORRECTION FACTOR (dB/m)
1	*2437.00	98.4 PK			1.98 V	255	67.94	30.46
2	*2437.00	96.2 AV			1.98 V	255	65.74	30.46
3	4874.00	55.2 PK	74.0	-18.8	1.68 V	90	18.32	36.92
4	<b>4874.00</b>	<b>53.0 AV</b>	<b>54.0</b>	<b>-1.0</b>	<b>1.68 V</b>	<b>90</b>	<b>16.06</b>	<b>36.92</b>
5	7311.00	52.3 PK	74.0	-21.7	1.25 V	13	9.17	43.14
6	7311.00	39.3 AV	54.0	-14.7	1.25 V	13	-3.87	43.14

- REMARKS:**
1. Emission level (dBuV/m) = Raw Value (dBuV) + Correction Factor (dB/m).
  2. Correction Factor (dB/m) = Antenna Factor (dB/m) + Cable Factor (dB).
  3. The other emission levels were very low against the limit.
  4. Margin value = Emission level – Limit value.
  5. “ \* “: Fundamental frequency.



A D T

EUT TEST CONDITION		MEASUREMENT DETAIL	
CHANNEL	Channel 11	FREQUENCY RANGE	1 ~ 25GHz
INPUT POWER (SYSTEM)	120Vac, 60 Hz	DETECTOR FUNCTION	Peak (PK) Average (AV)
ENVIRONMENTAL CONDITIONS	15deg. C, 68%RH 1022 hPa	TESTED BY	Duke Tseng

ANTENNA POLARITY & TEST DISTANCE: HORIZONTAL AT 3 M								
NO.	FREQ. (MHz)	EMISSION LEVEL (dBuV/m)	LIMIT (dBuV/m)	MARGIN (dB)	ANTENNA HEIGHT (m)	TABLE ANGLE (Degree)	RAW VALUE (dBuV)	CORRECTION FACTOR (dB/m)
1	*2462.00	100.8 PK			1.38 H	347	70.25	30.55
2	*2462.00	98.0 AV			1.38 H	347	67.43	30.55
3	2483.50	59.5 PK	74.0	-14.6	1.34 H	347	28.82	30.63
4	2483.50	44.0 AV	54.0	-10.0	1.34 H	347	13.40	30.63
5	4924.00	52.3 PK	74.0	-21.7	1.52 H	32	15.24	37.06
6	4924.00	47.2 AV	54.0	-6.8	1.52 H	32	10.14	37.06
7	7386.00	52.4 PK	74.0	-21.6	1.31 H	84	9.27	43.13
8	7386.00	38.9 AV	54.0	-15.1	1.31 H	84	-4.23	43.13
ANTENNA POLARITY & TEST DISTANCE: VERTICAL AT 3 M								
NO.	FREQ. (MHz)	EMISSION LEVEL (dBuV/m)	LIMIT (dBuV/m)	MARGIN (dB)	ANTENNA HEIGHT (m)	TABLE ANGLE (Degree)	RAW VALUE (dBuV)	CORRECTION FACTOR (dB/m)
1	*2462.00	98.9 PK			2.03 V	251	68.35	30.55
2	*2462.00	96.7 AV			2.03 V	251	66.15	30.55
3	2483.50	61.6 PK	74.0	-12.4	1.34 V	257	30.96	30.63
4	2483.50	43.9 AV	54.0	-10.1	1.34 V	257	13.28	30.63
5	4924.00	55.6 PK	74.0	-18.4	1.36 V	99	18.51	37.06
6	4924.00	52.8 AV	54.0	-1.2	1.36 V	99	15.74	37.06
7	7386.00	51.4 PK	74.0	-22.6	1.27 V	11	8.30	43.13
8	7386.00	37.9 AV	54.0	-16.1	1.27 V	11	-5.19	43.13

- REMARKS:**
1. Emission level (dBuV/m) = Raw Value (dBuV) + Correction Factor (dB/m).
  2. Correction Factor (dB/m) = Antenna Factor (dB/m) + Cable Factor (dB).
  3. The other emission levels were very low against the limit.
  4. Margin value = Emission level – Limit value.
  5. “ \* “: Fundamental frequency.





A D T

RESTRICTED BANDEDGE (802.11b MODE, CH1, HORIZONTAL )

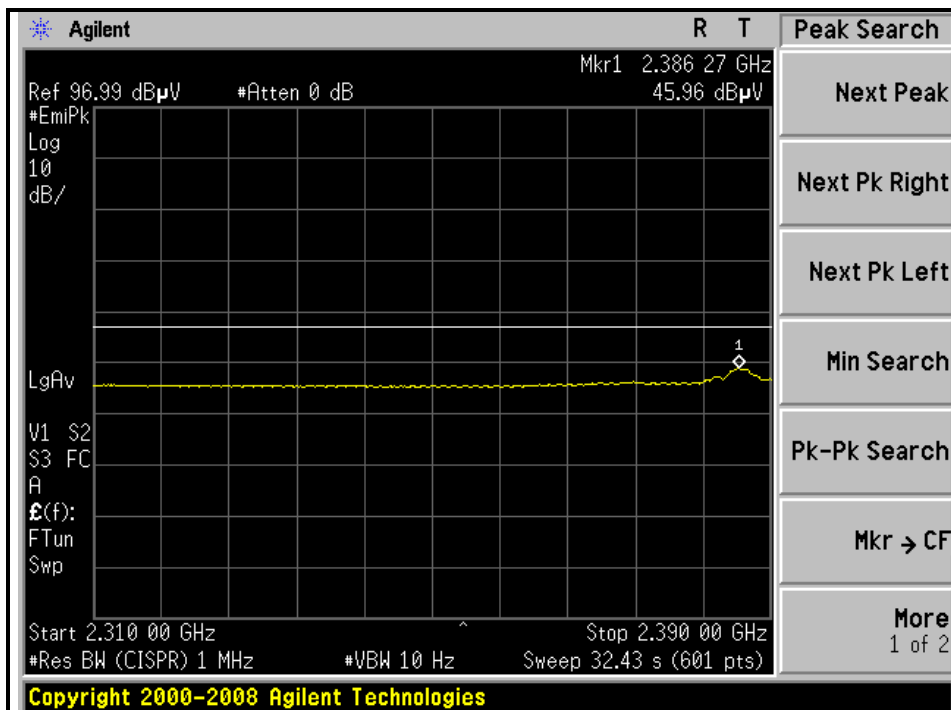
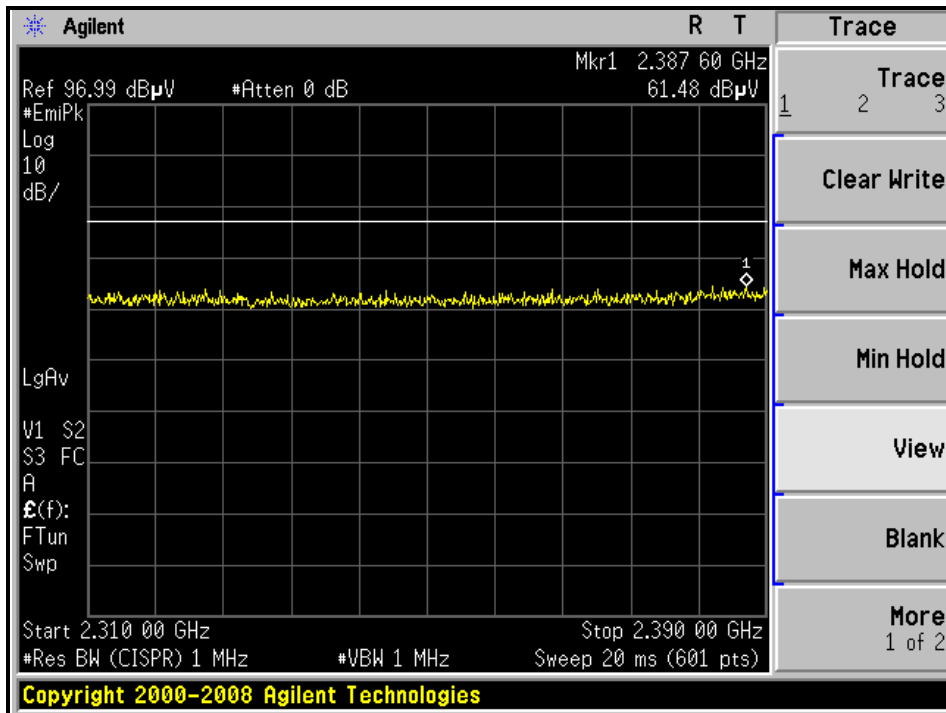



A D T

RESTRICTED BANDEDGE (802.11b MODE, CH1, VERTICAL )

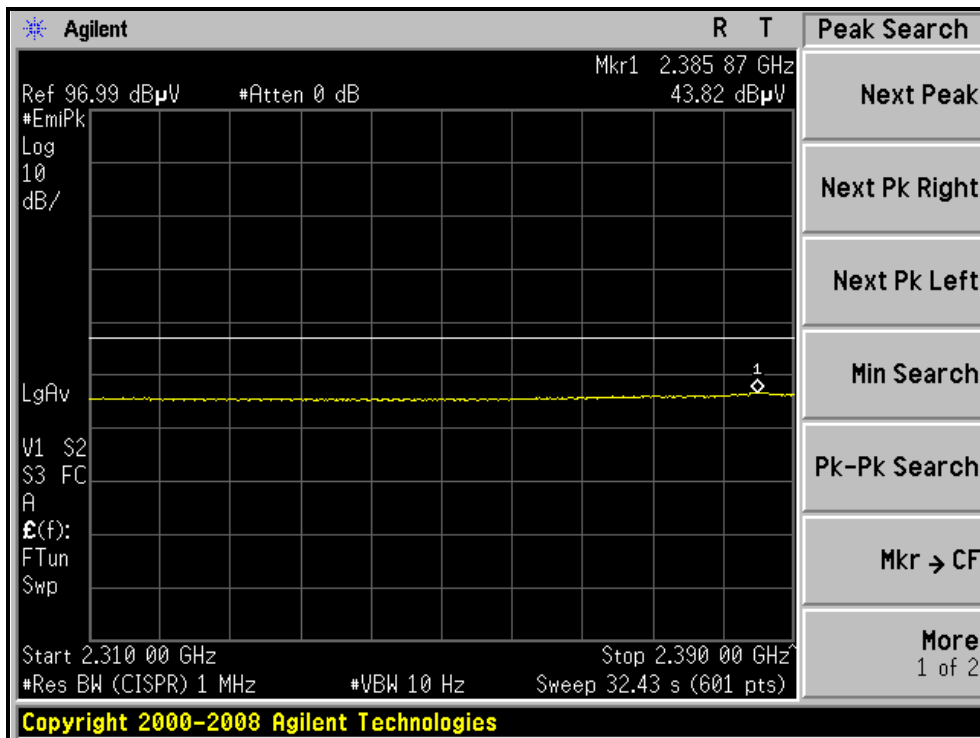
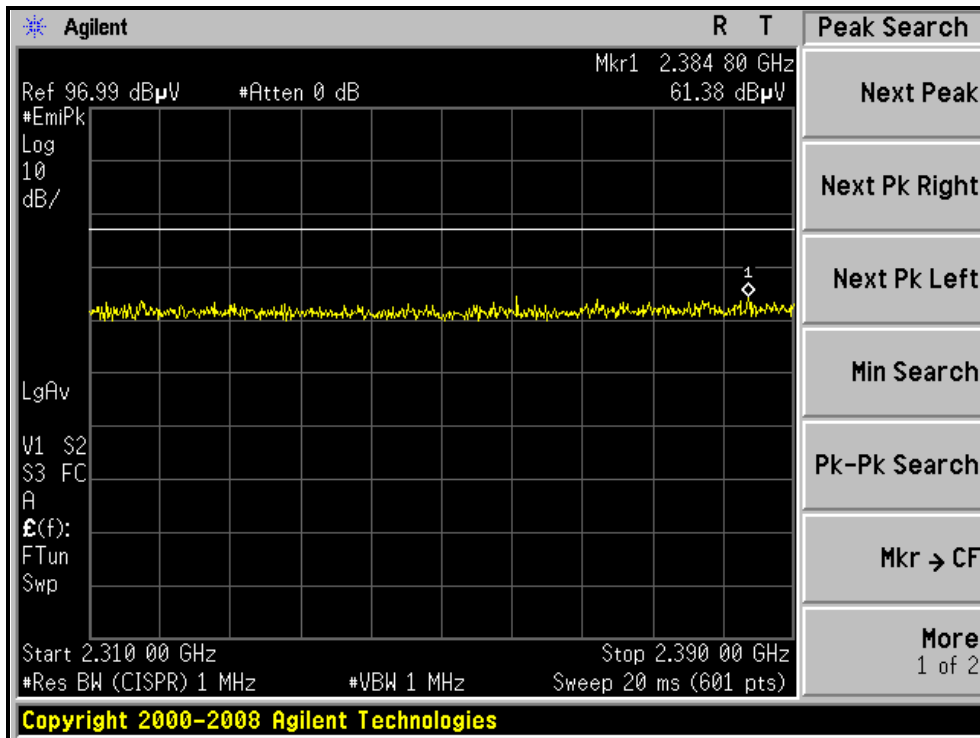



A D T

RESTRICTED BANDEDGE (802.11b MODE, CH11, HORIZONTAL )

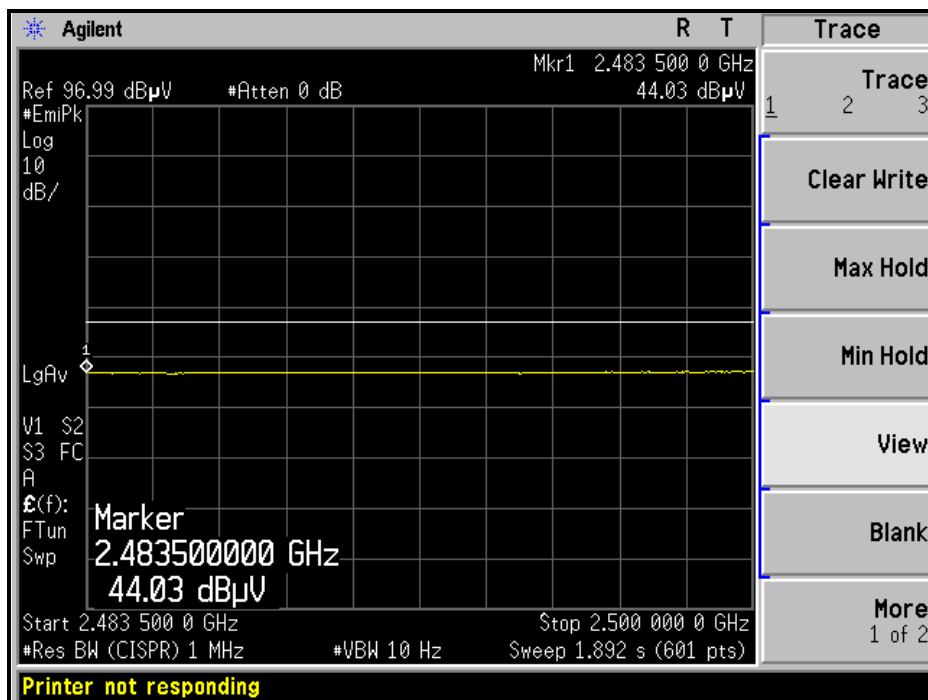
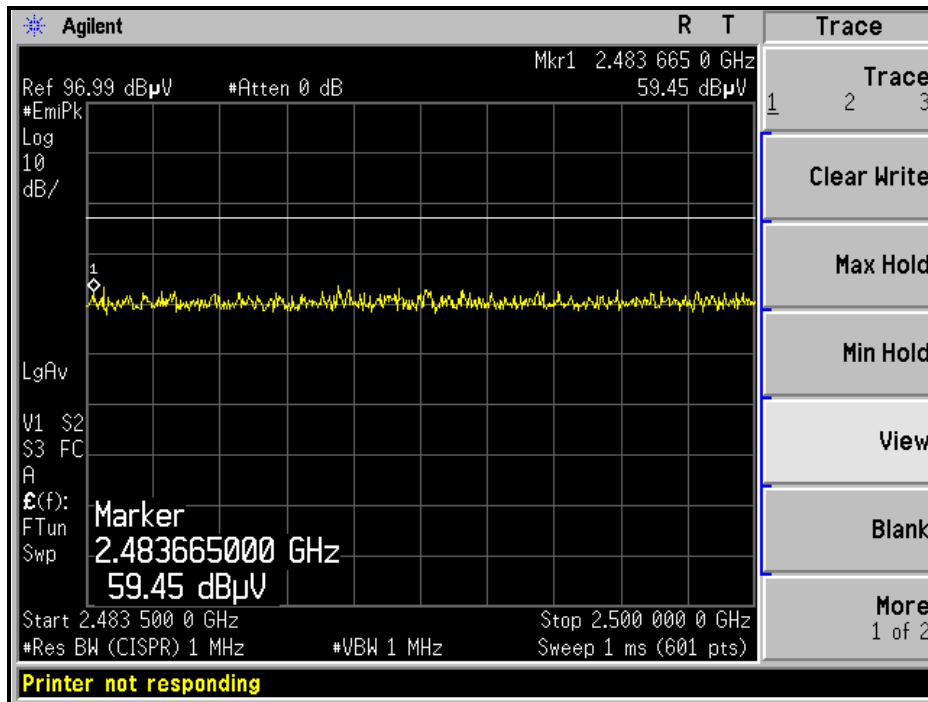



A D T

RESTRICTED BANDEDGE (802.11b MODE, CH11, VERTICAL )

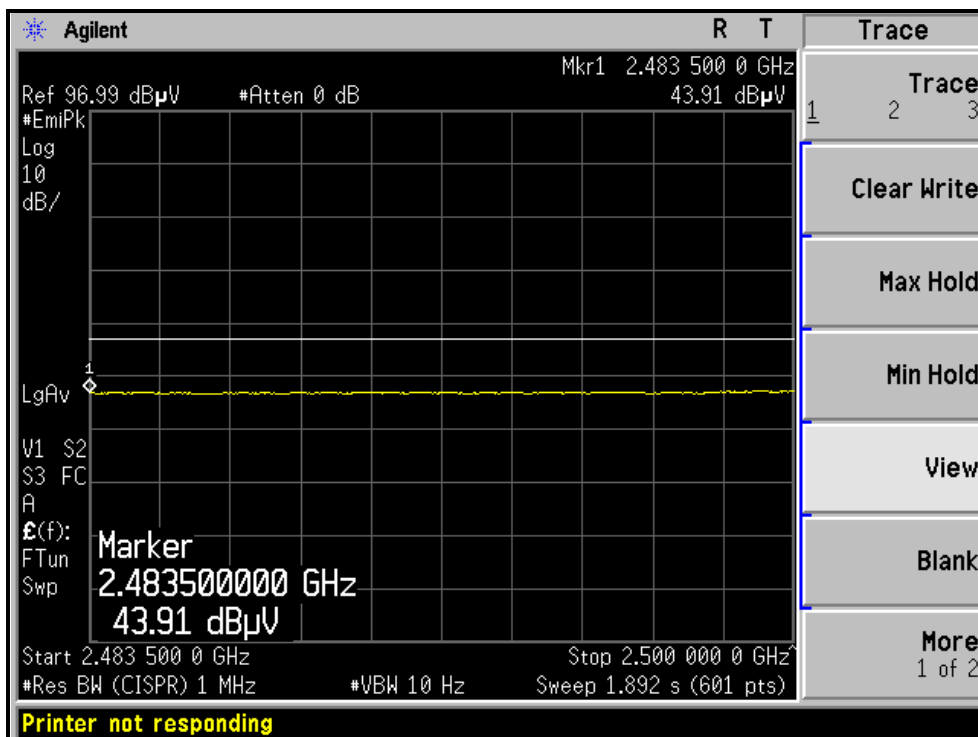
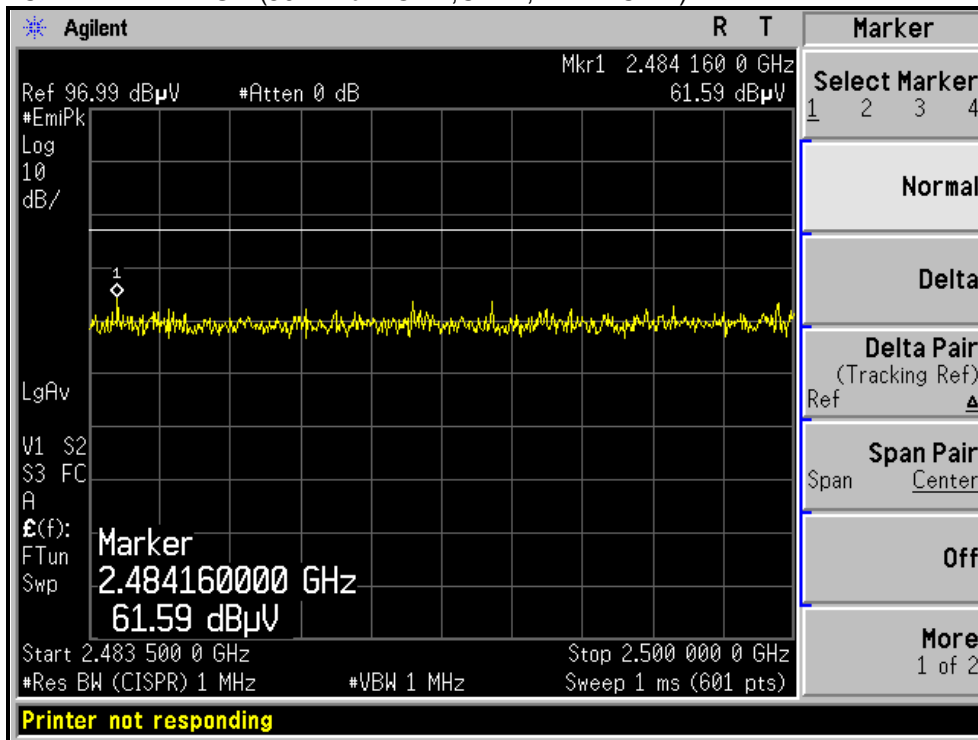



A D T

**802.11g OFDM MODULATION**

EUT TEST CONDITION		MEASUREMENT DETAIL	
CHANNEL	Channel 1	FREQUENCY RANGE	1 ~ 25GHz
INPUT POWER (SYSTEM)	120Vac, 60 Hz	DETECTOR FUNCTION	Peak (PK) Average (AV)
ENVIRONMENTAL CONDITIONS	15deg. C, 68%RH 1022 hPa	TESTED BY	Duke Tseng

**ANTENNA POLARITY & TEST DISTANCE: HORIZONTAL AT 3 M**

NO.	FREQ. (MHz)	EMISSION LEVEL (dBuV/m)	LIMIT (dBuV/m)	MARGIN (dB)	ANTENNA HEIGHT (m)	TABLE ANGLE (Degree)	RAW VALUE (dBuV)	CORRECTION FACTOR (dB/m)
1	2390.00	66.5 PK	74.0	-7.5	1.35 H	340	36.20	30.28
2	2390.00	49.5 AV	54.0	-4.6	1.35 H	340	19.17	30.28
3	*2412.00	100.9 PK			1.00 H	344	70.50	30.36
4	*2412.00	91.9 AV			1.00 H	344	61.57	30.36
5	4824.00	49.5 PK	74.0	-24.5	1.79 H	20	12.73	36.79
6	4824.00	36.2 AV	54.0	-17.8	1.79 H	20	-0.59	36.79

**ANTENNA POLARITY & TEST DISTANCE: VERTICAL AT 3 M**

NO.	FREQ. (MHz)	EMISSION LEVEL (dBuV/m)	LIMIT (dBuV/m)	MARGIN (dB)	ANTENNA HEIGHT (m)	TABLE ANGLE (Degree)	RAW VALUE (dBuV)	CORRECTION FACTOR (dB/m)
1	2390.00	59.5 PK	74.0	-14.6	1.00 V	342	29.17	30.28
2	2390.00	43.8 AV	54.0	-10.2	1.00 V	342	13.55	30.28
3	*2412.00	96.5 PK			2.11 V	223	66.18	30.36
4	*2412.00	87.2 AV			2.11 V	223	56.84	30.36
5	4824.00	51.5 PK	74.0	-22.5	1.34 V	253	14.67	36.79
6	4824.00	38.7 AV	54.0	-15.3	1.34 V	253	1.87	36.79

- REMARKS:**
1. Emission level (dBuV/m) = Raw Value (dBuV) + Correction Factor (dB/m).
  2. Correction Factor (dB/m) = Antenna Factor (dB/m) + Cable Factor (dB).
  3. The other emission levels were very low against the limit.
  4. Margin value = Emission level – Limit value.
  5. “ \* “: Fundamental frequency.



A D T

EUT TEST CONDITION		MEASUREMENT DETAIL	
CHANNEL	Channel 6	FREQUENCY RANGE	1 ~ 25GHz
INPUT POWER (SYSTEM)	120Vac, 60 Hz	DETECTOR FUNCTION	Peak (PK) Average (AV)
ENVIRONMENTAL CONDITIONS	15deg. C, 68%RH 1022 hPa	TESTED BY	Duke Tseng

ANTENNA POLARITY & TEST DISTANCE: HORIZONTAL AT 3 M								
NO.	FREQ. (MHz)	EMISSION LEVEL (dBuV/m)	LIMIT (dBuV/m)	MARGIN (dB)	ANTENNA HEIGHT (m)	TABLE ANGLE (Degree)	RAW VALUE (dBuV)	CORRECTION FACTOR (dB/m)
1	*2437.00	102.2 PK			1.35 H	343	71.74	30.46
2	*2437.00	93.0 AV			1.35 H	343	62.54	30.46
3	4874.00	49.7 PK	74.0	-24.3	1.84 H	32	12.78	36.92
4	4874.00	36.4 AV	54.0	-17.6	1.84 H	32	-0.52	36.92
5	7311.00	52.3 PK	74.0	-21.7	1.31 H	84	9.16	43.14
6	7311.00	38.4 AV	54.0	-15.6	1.31 H	84	-4.74	43.14
ANTENNA POLARITY & TEST DISTANCE: VERTICAL AT 3 M								
NO.	FREQ. (MHz)	EMISSION LEVEL (dBuV/m)	LIMIT (dBuV/m)	MARGIN (dB)	ANTENNA HEIGHT (m)	TABLE ANGLE (Degree)	RAW VALUE (dBuV)	CORRECTION FACTOR (dB/m)
1	*2437.00	96.9 PK			2.13 V	209	66.44	30.46
2	*2437.00	87.9 AV			2.13 V	209	57.44	30.46
3	4874.00	51.6 PK	74.0	-22.5	1.35 V	108	14.63	36.92
4	4874.00	37.4 AV	54.0	-16.6	1.35 V	108	0.49	36.92
5	7311.00	52.8 PK	74.0	-21.3	1.24 V	17	9.61	43.14
6	7311.00	38.2 AV	54.0	-15.8	1.24 V	17	-4.90	43.14

- REMARKS:**
1. Emission level (dBuV/m) = Raw Value (dBuV) + Correction Factor (dB/m).
  2. Correction Factor (dB/m) = Antenna Factor (dB/m) + Cable Factor (dB).
  3. The other emission levels were very low against the limit.
  4. Margin value = Emission level – Limit value.
  5. “ \* “: Fundamental frequency.



A D T

EUT TEST CONDITION		MEASUREMENT DETAIL	
CHANNEL	Channel 11	FREQUENCY RANGE	1 ~ 25GHz
INPUT POWER (SYSTEM)	120Vac, 60 Hz	DETECTOR FUNCTION	Peak (PK) Average (AV)
ENVIRONMENTAL CONDITIONS	15deg. C, 68%RH 1022 hPa	TESTED BY	Duke Tseng

**ANTENNA POLARITY & TEST DISTANCE: HORIZONTAL AT 3 M**

NO.	FREQ. (MHz)	EMISSION LEVEL (dBuV/m)	LIMIT (dBuV/m)	MARGIN (dB)	ANTENNA HEIGHT (m)	TABLE ANGLE (Degree)	RAW VALUE (dBuV)	CORRECTION FACTOR (dB/m)
1	*2462.00	100.5 PK			1.34 H	283	69.98	30.55
2	*2462.00	91.3 AV			1.34 H	283	60.73	30.55
3	2483.50	70.0 PK	74.0	-4.0	1.92 H	299	39.37	30.63
4	2483.50	50.1 AV	54.0	-3.9	1.92 H	299	19.43	30.63
5	4924.00	48.4 PK	74.0	-25.6	1.82 H	57	11.34	37.06
6	4924.00	32.3 AV	54.0	-21.7	1.82 H	57	-4.76	37.06
7	7386.00	52.1 PK	74.0	-21.9	1.34 H	79	8.97	43.13
8	7386.00	38.2 AV	54.0	-15.8	1.34 H	79	-4.93	43.13

**ANTENNA POLARITY & TEST DISTANCE: VERTICAL AT 3 M**

NO.	FREQ. (MHz)	EMISSION LEVEL (dBuV/m)	LIMIT (dBuV/m)	MARGIN (dB)	ANTENNA HEIGHT (m)	TABLE ANGLE (Degree)	RAW VALUE (dBuV)	CORRECTION FACTOR (dB/m)
1	*2462.00	96.2 PK			1.97 V	204	65.65	30.55
2	*2462.00	86.4 AV			1.97 V	204	55.85	30.55
3	2483.50	58.9 PK	74.0	-15.1	1.00 V	347	28.25	30.63
4	2483.50	46.5 AV	54.0	-7.5	1.00 V	347	15.90	30.63
5	4924.00	48.5 PK	74.0	-25.5	1.32 V	248	11.40	37.06
6	4924.00	34.7 AV	54.0	-19.4	1.32 V	248	-2.41	37.06
7	7386.00	52.0 PK	74.0	-22.0	1.23 V	12	8.83	43.13
8	7386.00	37.8 AV	54.0	-16.2	1.23 V	12	-5.29	43.13

- REMARKS:**
1. Emission level (dBuV/m) = Raw Value (dBuV) + Correction Factor (dB/m).
  2. Correction Factor (dB/m) = Antenna Factor (dB/m) + Cable Factor (dB).
  3. The other emission levels were very low against the limit.
  4. Margin value = Emission level – Limit value.
  5. “ \* “: Fundamental frequency.



A D T

### RESTRICTED BANDEDGE (802.11g MODE, CH1, HORIZONTAL )

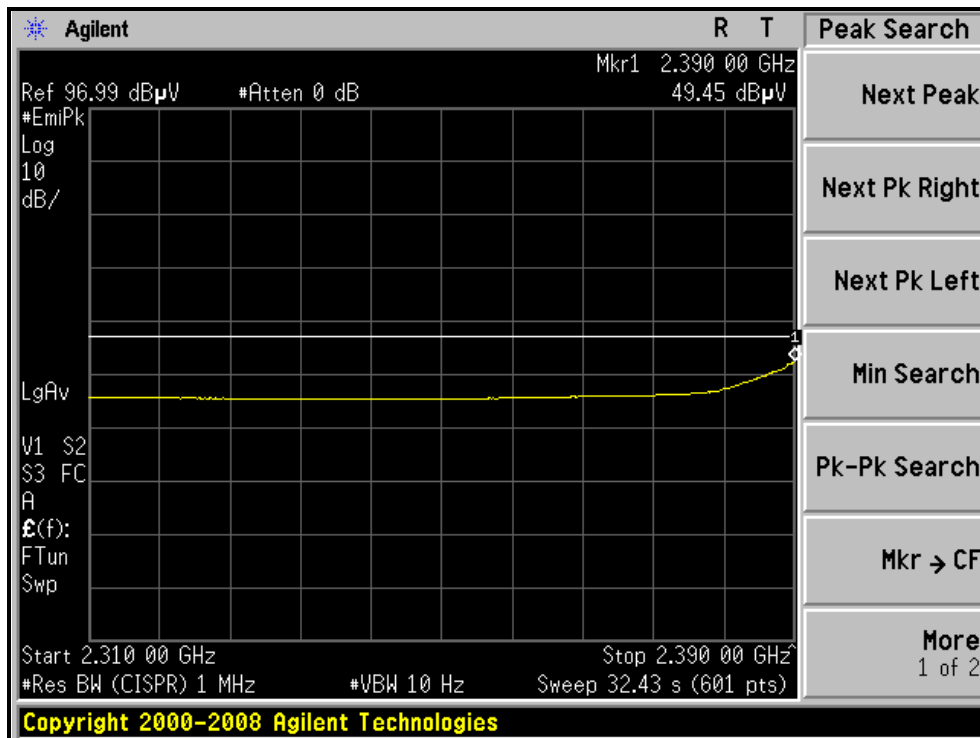
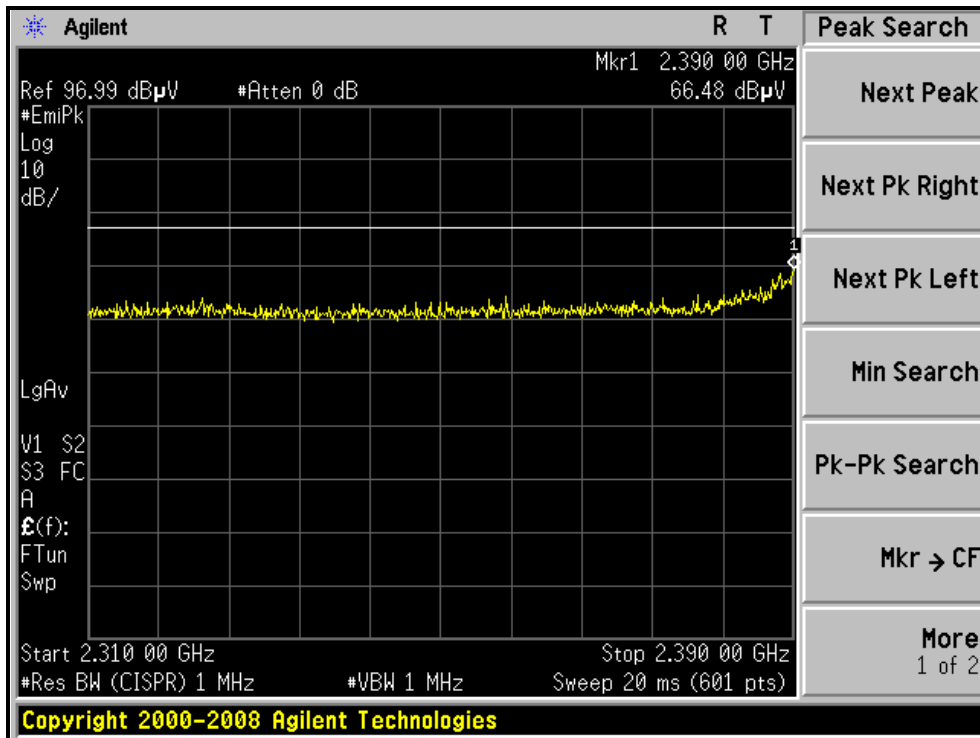





A D T

### RESTRICTED BANDEDGE (802.11g MODE, CH1, VERTICAL )

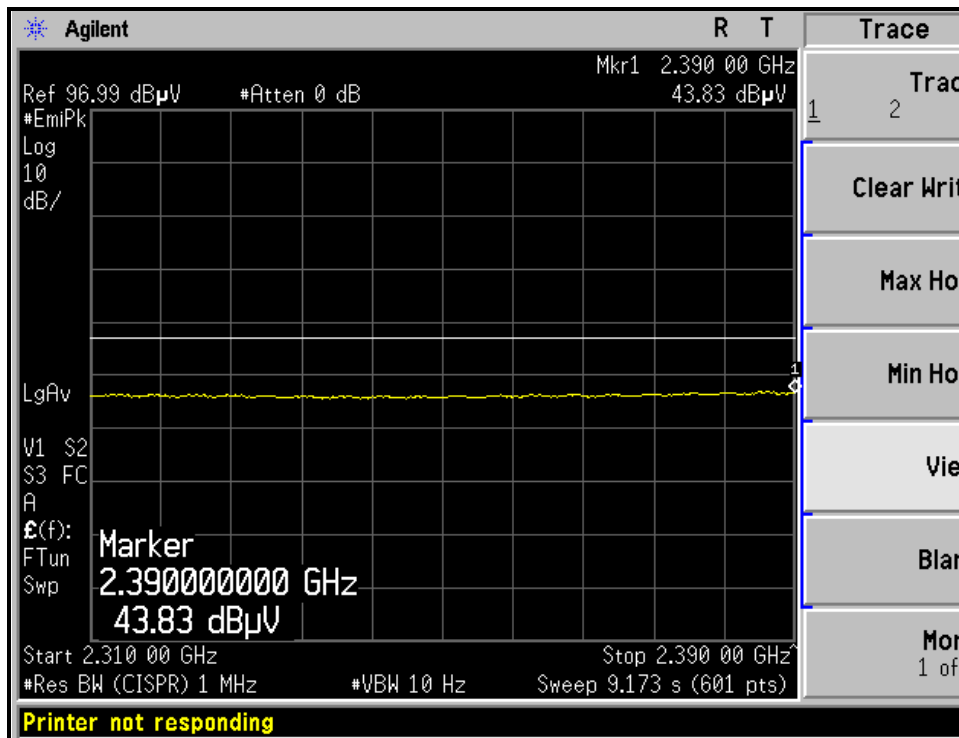
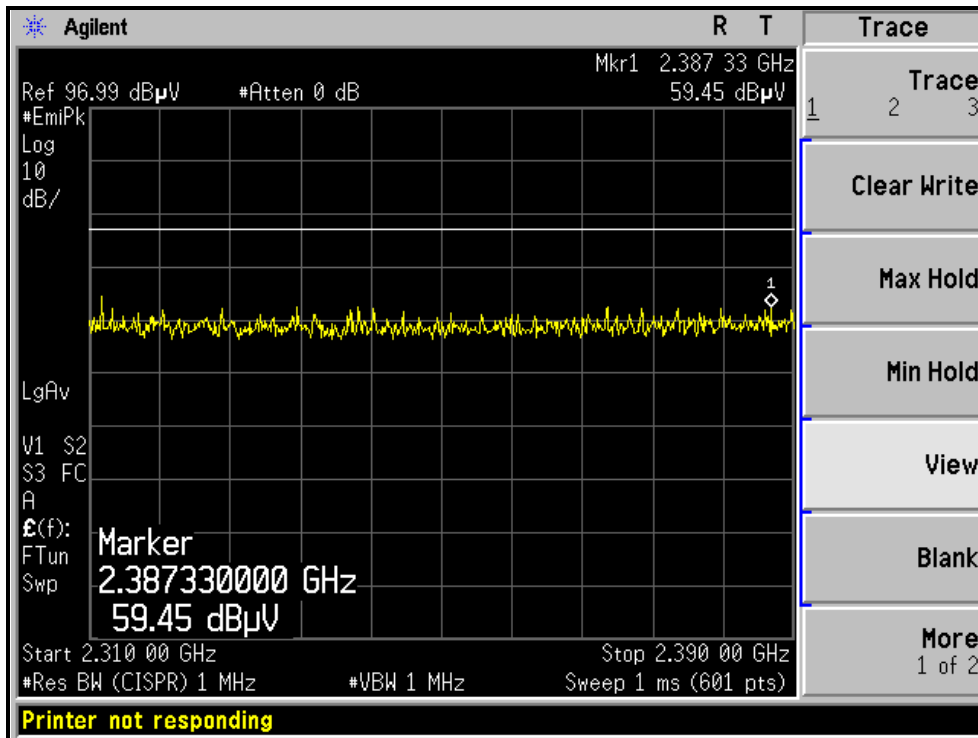



A D T

RESTRICTED BANDEDGE (802.11g MODE, CH11, HORIZONTAL )

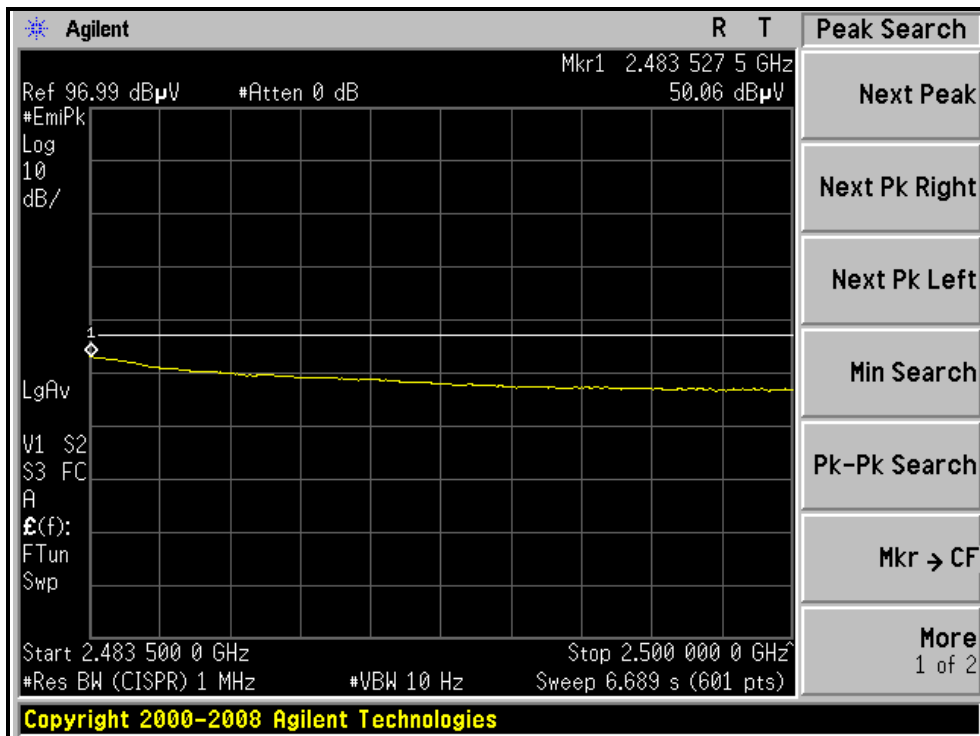
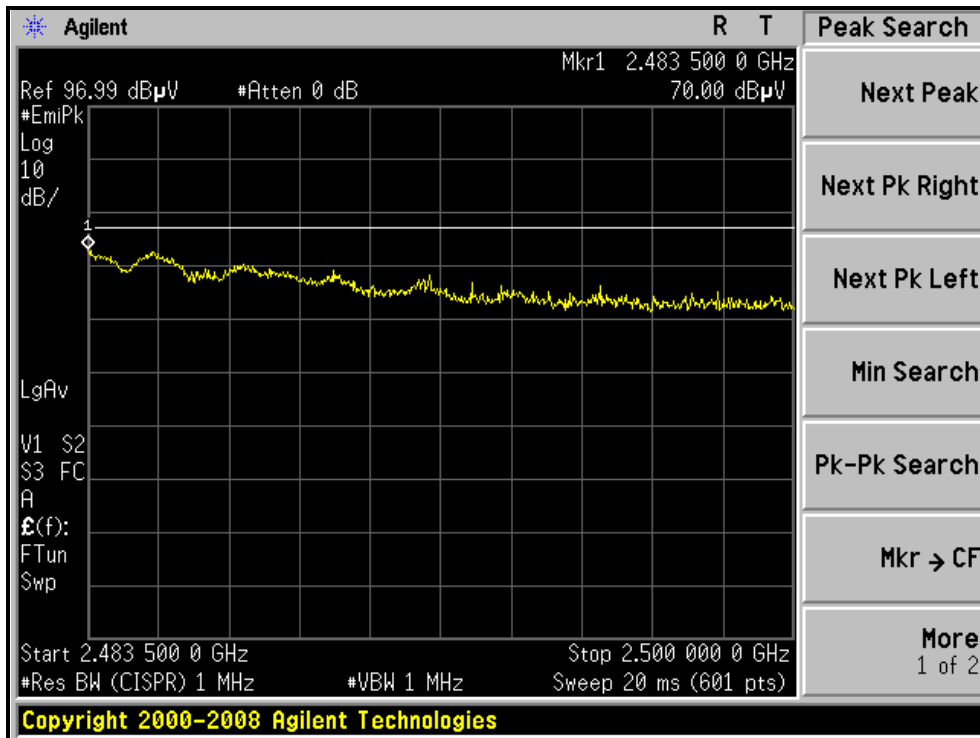



A D T

### RESTRICTED BANDEDGE (802.11g MODE, CH11, VERTICAL )

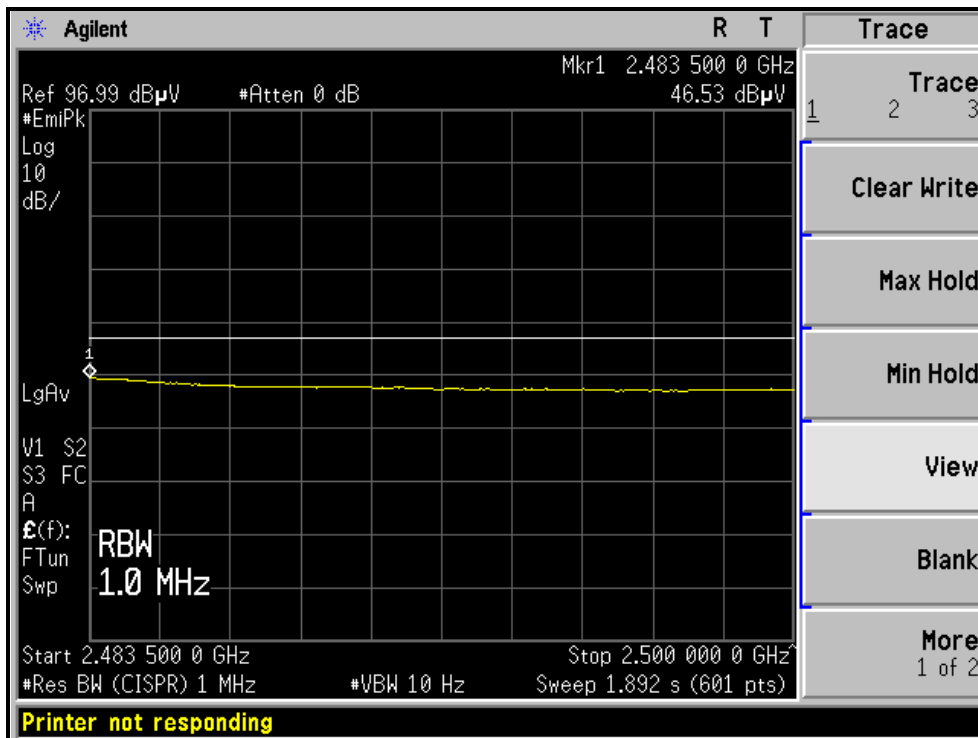
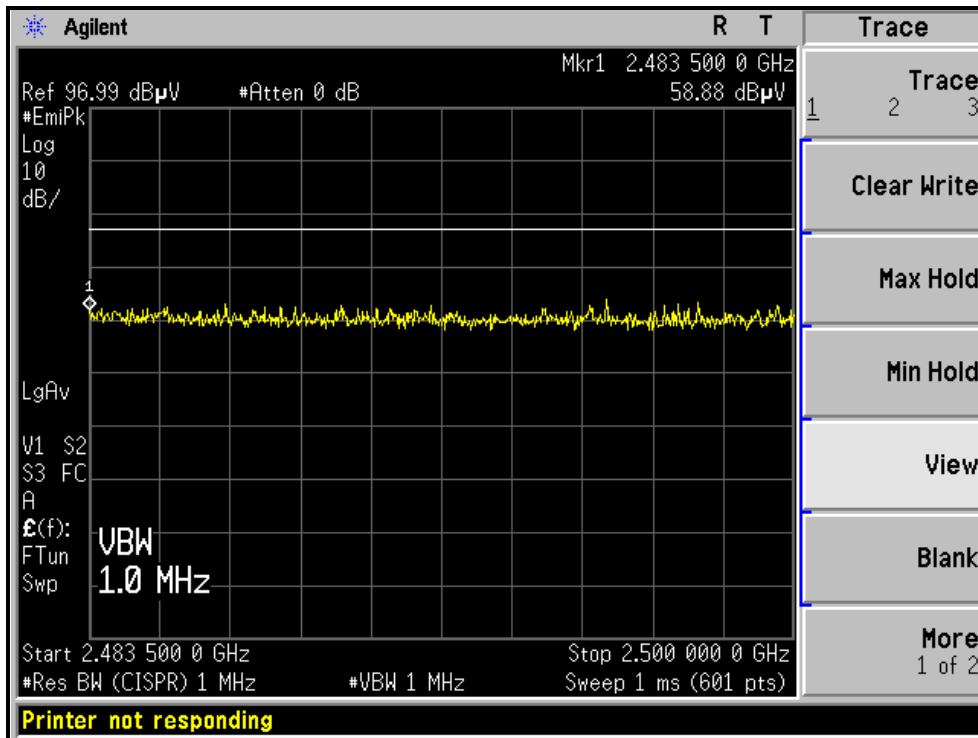



A D T

### 802.11n (20MHz) OFDM MODULATION

EUT TEST CONDITION		MEASUREMENT DETAIL	
CHANNEL	Channel 1	FREQUENCY RANGE	1 ~ 25GHz
INPUT POWER (SYSTEM)	120Vac, 60 Hz	DETECTOR FUNCTION	Peak (PK) Average (AV)
ENVIRONMENTAL CONDITIONS	15deg. C, 68%RH 1022 hPa	TESTED BY	Duke Tseng

ANTENNA POLARITY & TEST DISTANCE: HORIZONTAL AT 3 M								
NO.	FREQ. (MHz)	EMISSION LEVEL (dBuV/m)	LIMIT (dBuV/m)	MARGIN (dB)	ANTENNA HEIGHT (m)	TABLE ANGLE (Degree)	RAW VALUE (dBuV)	CORRECTION FACTOR (dB/m)
1	2390.00	67.8 PK	74.0	-6.2	1.98 H	307	37.51	30.28
2	2390.00	49.0 AV	54.0	-5.0	1.98 H	307	18.75	30.28
3	*2412.00	103.5 PK			1.35 H	285	73.11	30.36
4	*2412.00	94.2 AV			1.35 H	285	63.87	30.36
5	4824.00	49.4 PK	74.0	-24.6	1.73 H	18	12.61	36.79
6	4824.00	34.3 AV	54.0	-19.7	1.73 H	18	-2.49	36.79
ANTENNA POLARITY & TEST DISTANCE: VERTICAL AT 3 M								
NO.	FREQ. (MHz)	EMISSION LEVEL (dBuV/m)	LIMIT (dBuV/m)	MARGIN (dB)	ANTENNA HEIGHT (m)	TABLE ANGLE (Degree)	RAW VALUE (dBuV)	CORRECTION FACTOR (dB/m)
1	2390.00	58.5 PK	74.0	-15.5	1.00 V	342	28.23	30.28
2	2390.00	43.5 AV	54.0	-10.5	1.00 V	342	13.20	30.28
3	*2412.00	96.1 PK			1.73 V	202	65.74	30.36
4	*2412.00	85.4 AV			1.73 V	202	55.04	30.36
5	4824.00	51.4 PK	74.0	-22.6	1.35 V	263	14.57	36.79
6	4824.00	36.9 AV	54.0	-17.2	1.35 V	263	0.06	36.79

- REMARKS:**
1. Emission level (dBuV/m) = Raw Value (dBuV) + Correction Factor (dB/m).
  2. Correction Factor (dB/m) = Antenna Factor (dB/m) + Cable Factor (dB).
  3. The other emission levels were very low against the limit.
  4. Margin value = Emission level – Limit value.
  5. “ \* “: Fundamental frequency.



A D T

EUT TEST CONDITION		MEASUREMENT DETAIL	
CHANNEL	Channel 6	FREQUENCY RANGE	1 ~ 25GHz
INPUT POWER (SYSTEM)	120Vac, 60 Hz	DETECTOR FUNCTION	Peak (PK) Average (AV)
ENVIRONMENTAL CONDITIONS	15deg. C, 68%RH 1022 hPa	TESTED BY	Duke Tseng

ANTENNA POLARITY & TEST DISTANCE: HORIZONTAL AT 3 M								
NO.	FREQ. (MHz)	EMISSION LEVEL (dBuV/m)	LIMIT (dBuV/m)	MARGIN (dB)	ANTENNA HEIGHT (m)	TABLE ANGLE (Degree)	RAW VALUE (dBuV)	CORRECTION FACTOR (dB/m)
1	*2437.00	102.8 PK			1.99 H	304	72.34	30.46
2	*2437.00	93.5 AV			1.99 H	304	63.08	30.46
3	4874.00	48.5 PK	74.0	-25.5	1.12 H	25	11.58	36.92
4	4874.00	33.4 AV	54.0	-20.6	1.12 H	25	-3.52	36.92
5	7311.00	52.6 PK	74.0	-21.4	1.29 H	73	9.46	43.14
6	7311.00	38.4 AV	54.0	-15.6	1.29 H	73	-4.74	43.14
ANTENNA POLARITY & TEST DISTANCE: VERTICAL AT 3 M								
NO.	FREQ. (MHz)	EMISSION LEVEL (dBuV/m)	LIMIT (dBuV/m)	MARGIN (dB)	ANTENNA HEIGHT (m)	TABLE ANGLE (Degree)	RAW VALUE (dBuV)	CORRECTION FACTOR (dB/m)
1	*2437.00	96.2 PK			1.82 V	204	65.74	30.46
2	*2437.00	85.7 AV			1.82 V	204	55.24	30.46
3	4874.00	50.3 PK	74.0	-23.7	1.33 V	254	13.38	36.92
4	4874.00	35.2 AV	54.0	-18.8	1.33 V	254	-1.72	36.92
5	7311.00	52.6 PK	74.0	-21.4	1.19 V	21	9.44	43.14
6	7311.00	38.0 AV	54.0	-16.0	1.19 V	21	-5.14	43.14

- REMARKS:**
1. Emission level (dBuV/m) = Raw Value (dBuV) + Correction Factor (dB/m).
  2. Correction Factor (dB/m) = Antenna Factor (dB/m) + Cable Factor (dB).
  3. The other emission levels were very low against the limit.
  4. Margin value = Emission level – Limit value.
  5. “ \* “: Fundamental frequency.



A D T

EUT TEST CONDITION		MEASUREMENT DETAIL	
CHANNEL	Channel 11	FREQUENCY RANGE	1 ~ 25GHz
INPUT POWER (SYSTEM)	120Vac, 60 Hz	DETECTOR FUNCTION	Peak (PK) Average (AV)
ENVIRONMENTAL CONDITIONS	15deg. C, 68%RH 1022 hPa	TESTED BY	Duke Tseng

ANTENNA POLARITY & TEST DISTANCE: HORIZONTAL AT 3 M								
NO.	FREQ. (MHz)	EMISSION LEVEL (dBuV/m)	LIMIT (dBuV/m)	MARGIN (dB)	ANTENNA HEIGHT (m)	TABLE ANGLE (Degree)	RAW VALUE (dBuV)	CORRECTION FACTOR (dB/m)
1	*2462.00	100.2 PK			1.35 H	284	69.62	30.55
2	*2462.00	90.3 AV			1.35 H	284	59.79	30.55
3	2483.50	69.9 PK	74.0	-4.2	1.92 H	317	39.22	30.63
4	2483.50	50.7 AV	54.0	-3.3	1.92 H	317	20.08	30.63
5	4924.00	49.2 PK	74.0	-24.8	1.44 H	27	12.14	37.06
6	4924.00	33.8 AV	54.0	-20.2	1.44 H	27	-3.26	37.06
7	7386.00	52.6 PK	74.0	-21.4	1.31 H	82	9.47	43.13
8	7386.00	38.4 AV	54.0	-15.6	1.31 H	82	-4.73	43.13
ANTENNA POLARITY & TEST DISTANCE: VERTICAL AT 3 M								
NO.	FREQ. (MHz)	EMISSION LEVEL (dBuV/m)	LIMIT (dBuV/m)	MARGIN (dB)	ANTENNA HEIGHT (m)	TABLE ANGLE (Degree)	RAW VALUE (dBuV)	CORRECTION FACTOR (dB/m)
1	*2462.00	95.7 PK			1.84 V	209	65.15	30.55
2	*2462.00	85.2 AV			1.84 V	209	54.65	30.55
3	2483.50	60.0 PK	74.0	-14.0	1.00 V	344	29.37	30.63
4	2483.50	46.2 AV	54.0	-7.8	1.00 V	344	15.58	30.63
5	4924.00	48.5 PK	74.0	-25.5	1.33 V	243	11.47	37.06
6	4924.00	34.2 AV	54.0	-19.8	1.33 V	243	-2.85	37.06
7	7386.00	51.7 PK	74.0	-22.3	1.25 V	28	8.56	43.13
8	7386.00	37.7 AV	54.0	-16.3	1.25 V	28	-5.39	43.13

- REMARKS:**
1. Emission level (dBuV/m) = Raw Value (dBuV) + Correction Factor (dB/m).
  2. Correction Factor (dB/m) = Antenna Factor (dB/m) + Cable Factor (dB).
  3. The other emission levels were very low against the limit.
  4. Margin value = Emission level – Limit value.
  5. “ \* “: Fundamental frequency.



A D T

RESTRICTED BANDEDGE (802.11n (20MHz) MODE, CH1, HORIZONTAL )

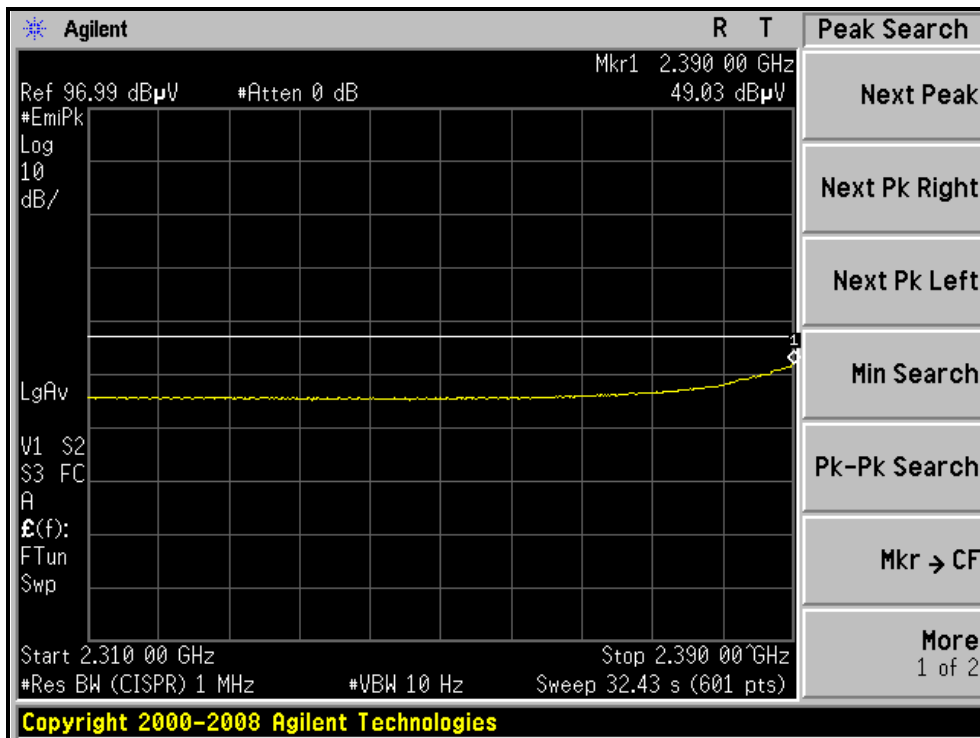
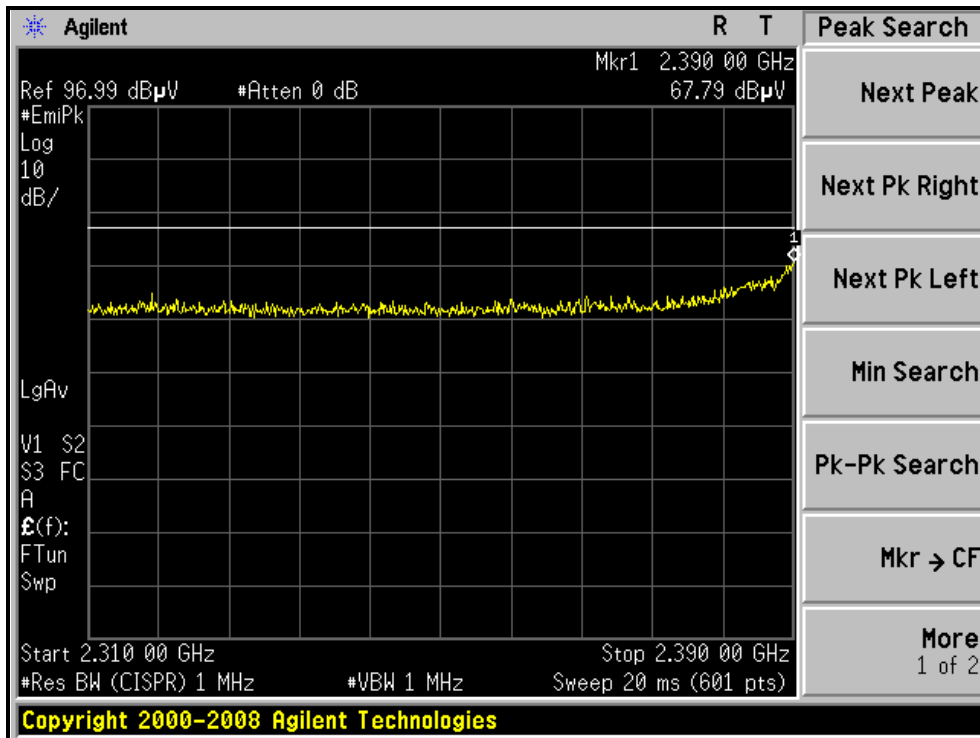



A D T

RESTRICTED BANDEDGE (802.11n (20MHz) MODE,CH1, VERTICAL )

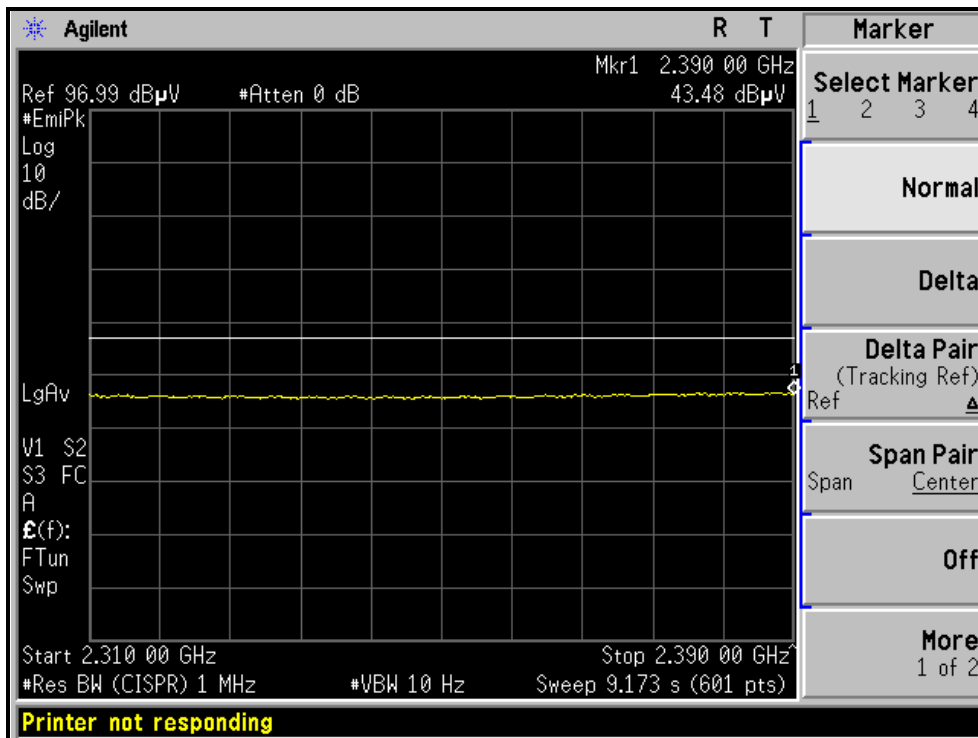
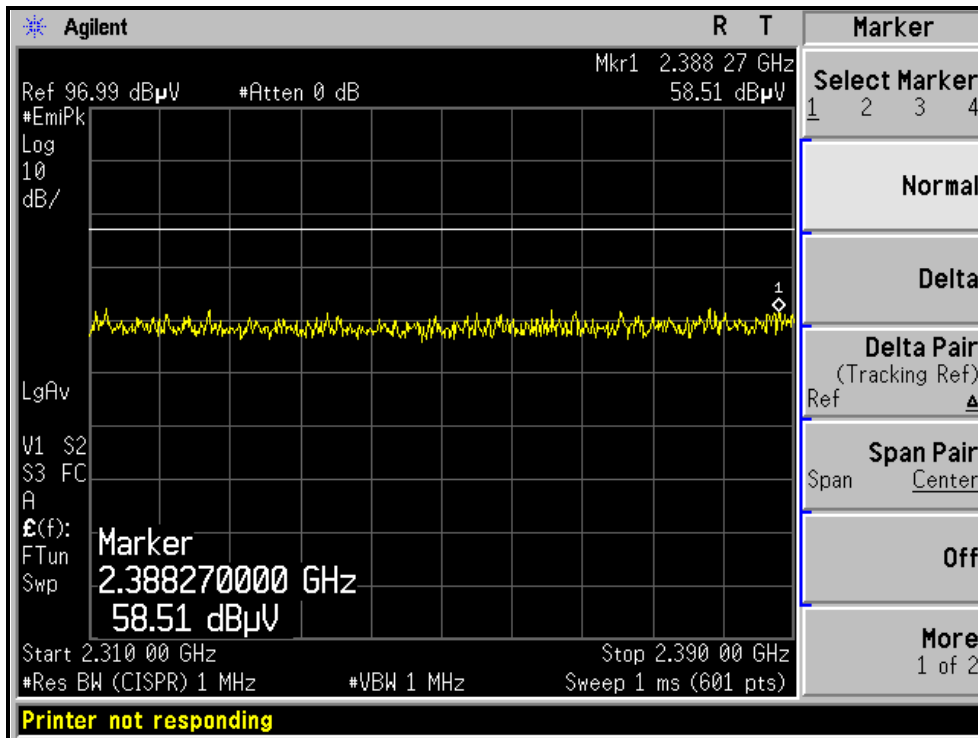





A D T

RESTRICTED BANDEDGE (802.11n (20MHz) MODE, CH11, HORIZONTAL )

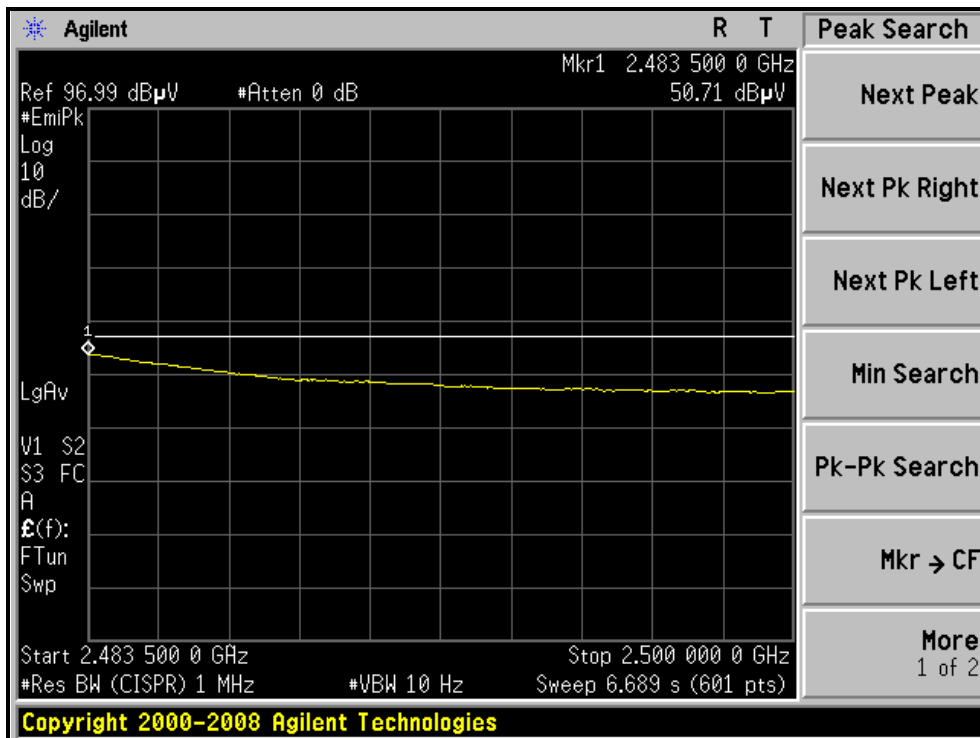
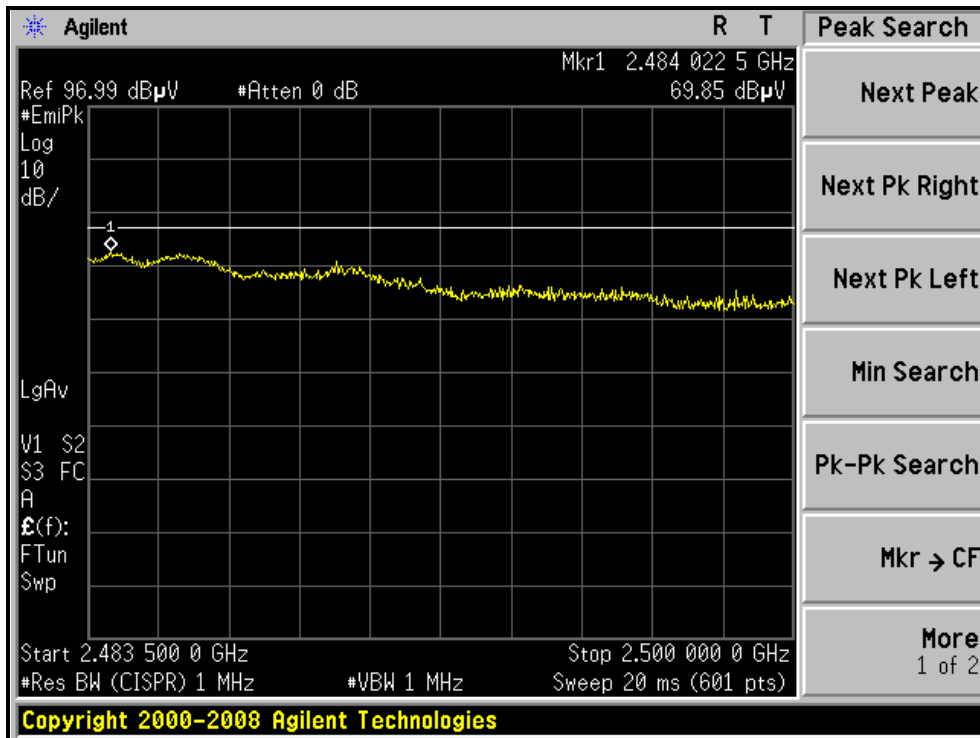



A D T

RESTRICTED BANDEDGE (802.11n (20MHz) MODE,CH11, VERTICAL )

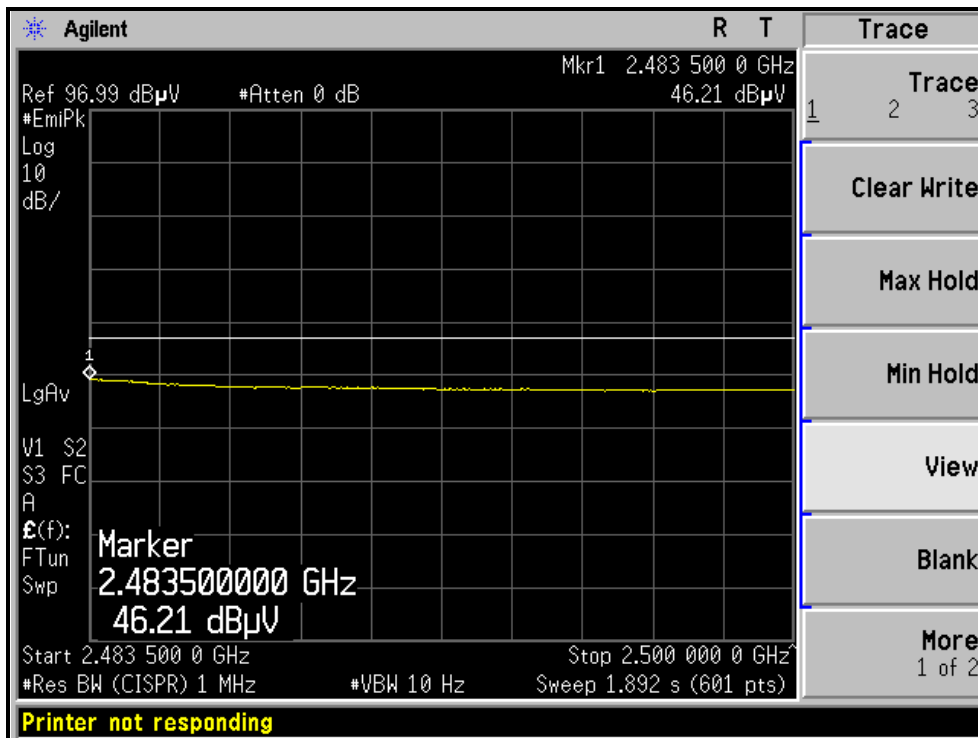
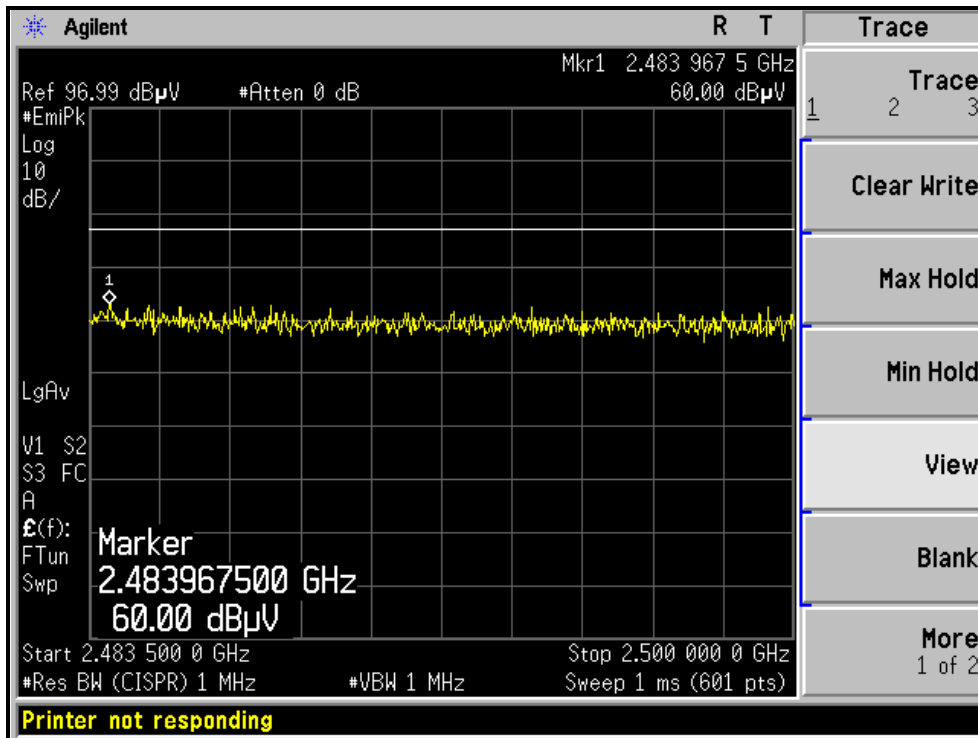



A D T

**802.11n (40MHz) OFDM MODULATION**

EUT TEST CONDITION		MEASUREMENT DETAIL	
CHANNEL	Channel 1	FREQUENCY RANGE	1 ~ 25GHz
INPUT POWER (SYSTEM)	120Vac, 60 Hz	DETECTOR FUNCTION	Peak (PK) Average (AV)
ENVIRONMENTAL CONDITIONS	15deg. C, 68%RH 1022 hPa	TESTED BY	Duke Tseng

ANTENNA POLARITY & TEST DISTANCE: HORIZONTAL AT 3 M								
NO.	FREQ. (MHz)	EMISSION LEVEL (dBuV/m)	LIMIT (dBuV/m)	MARGIN (dB)	ANTENNA HEIGHT (m)	TABLE ANGLE (Degree)	RAW VALUE (dBuV)	CORRECTION FACTOR (dB/m)
1	2390.00	62.7 PK	74.0	-11.3	1.35 H	342	32.40	30.28
2	2390.00	46.8 AV	54.0	-7.3	1.35 H	342	16.47	30.28
3	*2422.00	98.0 PK			1.34 H	344	67.64	30.40
4	*2422.00	89.2 AV			1.34 H	344	58.81	30.40
5	4844.00	46.8 PK	74.0	-27.2	1.14 H	23	9.96	36.84
6	4844.00	33.6 AV	54.0	-20.4	1.14 H	23	-3.24	36.84
7	7266.00	52.9 PK	74.0	-21.1	1.27 H	84	9.76	43.14
8	7266.00	38.4 AV	54.0	-15.6	1.27 H	84	-4.74	43.14

ANTENNA POLARITY & TEST DISTANCE: VERTICAL AT 3 M								
NO.	FREQ. (MHz)	EMISSION LEVEL (dBuV/m)	LIMIT (dBuV/m)	MARGIN (dB)	ANTENNA HEIGHT (m)	TABLE ANGLE (Degree)	RAW VALUE (dBuV)	CORRECTION FACTOR (dB/m)
1	2390.00	60.4 PK	74.0	-13.6	1.00 V	284	30.08	30.28
2	2390.00	46.0 AV	54.0	-8.0	1.00 V	284	15.73	30.28
3	*2422.00	94.3 PK			2.11 V	197	63.90	30.40
4	*2422.00	85.2 AV			2.11 V	197	54.80	30.40
5	4844.00	48.0 PK	74.0	-26.0	1.36 V	102	11.12	36.84
6	4844.00	34.7 AV	54.0	-19.3	1.36 V	102	-2.15	36.84
7	7266.00	52.1 PK	74.0	-21.9	1.23 V	11	8.94	43.14
8	7266.00	38.1 AV	54.0	-15.9	1.23 V	11	-5.03	43.14

- REMARKS:**
1. Emission level (dBuV/m) = Raw Value (dBuV) + Correction Factor (dB/m).
  2. Correction Factor (dB/m) = Antenna Factor (dB/m) + Cable Factor (dB).
  3. The other emission levels were very low against the limit.
  4. Margin value = Emission level – Limit value.
  5. “ \* “: Fundamental frequency.



A D T

EUT TEST CONDITION		MEASUREMENT DETAIL	
CHANNEL	Channel 4	FREQUENCY RANGE	1 ~ 25GHz
INPUT POWER (SYSTEM)	120Vac, 60 Hz	DETECTOR FUNCTION	Peak (PK) Average (AV)
ENVIRONMENTAL CONDITIONS	15deg. C, 68%RH 1022 hPa	TESTED BY	Duke Tseng

ANTENNA POLARITY & TEST DISTANCE: HORIZONTAL AT 3 M								
NO.	FREQ. (MHz)	EMISSION LEVEL (dBuV/m)	LIMIT (dBuV/m)	MARGIN (dB)	ANTENNA HEIGHT (m)	TABLE ANGLE (Degree)	RAW VALUE (dBuV)	CORRECTION FACTOR (dB/m)
1	*2437.00	98.8 PK			1.90 H	310	68.35	30.46
2	*2437.00	89.3 AV			1.90 H	310	58.81	30.46
3	4874.00	46.2 PK	74.0	-27.8	1.17 H	35	9.28	36.92
4	4874.00	33.3 AV	54.0	-20.7	1.17 H	35	-3.62	36.92
5	7311.00	53.1 PK	74.0	-20.9	1.32 H	79	9.96	43.14
6	7311.00	38.2 AV	54.0	-15.8	1.32 H	79	-4.94	43.14
ANTENNA POLARITY & TEST DISTANCE: VERTICAL AT 3 M								
NO.	FREQ. (MHz)	EMISSION LEVEL (dBuV/m)	LIMIT (dBuV/m)	MARGIN (dB)	ANTENNA HEIGHT (m)	TABLE ANGLE (Degree)	RAW VALUE (dBuV)	CORRECTION FACTOR (dB/m)
1	*2437.00	94.2 PK			2.16 V	193	63.74	30.46
2	*2437.00	85.7 AV			2.16 V	193	55.24	30.46
3	4874.00	47.2 PK	74.0	-26.8	1.37 V	101	10.31	36.92
4	4874.00	34.2 AV	54.0	-19.9	1.37 V	101	-2.77	36.92
5	7311.00	51.6 PK	74.0	-22.4	1.26 V	27	8.49	43.14
6	7311.00	38.0 AV	54.0	-16.0	1.26 V	27	-5.11	43.14

- REMARKS:**
1. Emission level (dBuV/m) = Raw Value (dBuV) + Correction Factor (dB/m).
  2. Correction Factor (dB/m) = Antenna Factor (dB/m) + Cable Factor (dB).
  3. The other emission levels were very low against the limit.
  4. Margin value = Emission level – Limit value.
  5. “ \* “: Fundamental frequency.



A D T

EUT TEST CONDITION		MEASUREMENT DETAIL	
CHANNEL	Channel 7	FREQUENCY RANGE	1 ~ 25GHz
INPUT POWER (SYSTEM)	120Vac, 60 Hz	DETECTOR FUNCTION	Peak (PK) Average (AV)
ENVIRONMENTAL CONDITIONS	15deg. C, 68%RH 1022 hPa	TESTED BY	Duke Tseng

**ANTENNA POLARITY & TEST DISTANCE: HORIZONTAL AT 3 M**

NO.	FREQ. (MHz)	EMISSION LEVEL (dBuV/m)	LIMIT (dBuV/m)	MARGIN (dB)	ANTENNA HEIGHT (m)	TABLE ANGLE (Degree)	RAW VALUE (dBuV)	CORRECTION FACTOR (dB/m)
1	*2452.00	97.6 PK			1.90 H	310	67.09	30.51
2	*2452.00	87.9 AV			1.90 H	310	57.34	30.51
3	2483.75	69.1 PK	74.0	-4.9	1.95 H	321	38.44	30.63
4	2483.75	52.6 AV	54.0	-1.4	1.95 H	321	22.00	30.63
5	2487.68	69.8 PK	74.0	-4.2	1.92 H	31	39.17	30.64
6	2487.68	51.2 AV	54.0	-2.8	1.92 H	31	20.55	30.64
7	4904.00	46.8 PK	74.0	-27.2	1.14 H	63	9.80	37.00
8	4904.00	33.7 AV	54.0	-20.3	1.14 H	63	-3.30	37.00
9	7356.00	53.4 PK	74.0	-20.6	1.36 H	84	10.27	43.13
10	7356.00	38.9 AV	54.0	-15.1	1.36 H	84	-4.23	43.13

**ANTENNA POLARITY & TEST DISTANCE: VERTICAL AT 3 M**

NO.	FREQ. (MHz)	EMISSION LEVEL (dBuV/m)	LIMIT (dBuV/m)	MARGIN (dB)	ANTENNA HEIGHT (m)	TABLE ANGLE (Degree)	RAW VALUE (dBuV)	CORRECTION FACTOR (dB/m)
1	*2452.00	93.6 PK			2.12 V	182	63.09	30.51
2	*2452.00	84.3 AV			2.12 V	182	53.79	30.51
3	2483.50	59.9 PK	74.0	-14.1	1.10 V	261	29.27	30.63
4	2483.50	45.4 AV	54.0	-8.6	1.10 V	261	14.81	30.63
5	4904.00	46.1 PK	74.0	-27.9	1.35 V	198	9.12	37.00
6	4904.00	33.6 AV	54.0	-20.4	1.35 V	198	-3.38	37.00
7	7356.00	51.1 PK	74.0	-22.9	1.20 V	12	7.99	43.13
8	7356.00	37.9 AV	54.0	-16.2	1.20 V	12	-5.28	43.13

- REMARKS:**
1. Emission level (dBuV/m) = Raw Value (dBuV) + Correction Factor (dB/m).
  2. Correction Factor (dB/m) = Antenna Factor (dB/m) + Cable Factor (dB).
  3. The other emission levels were very low against the limit.
  4. Margin value = Emission level – Limit value.
  5. “ \* “: Fundamental frequency.



A D T

RESTRICTED BANDEDGE (802.11n (40MHz) MODE, CH1, HORIZONTAL )

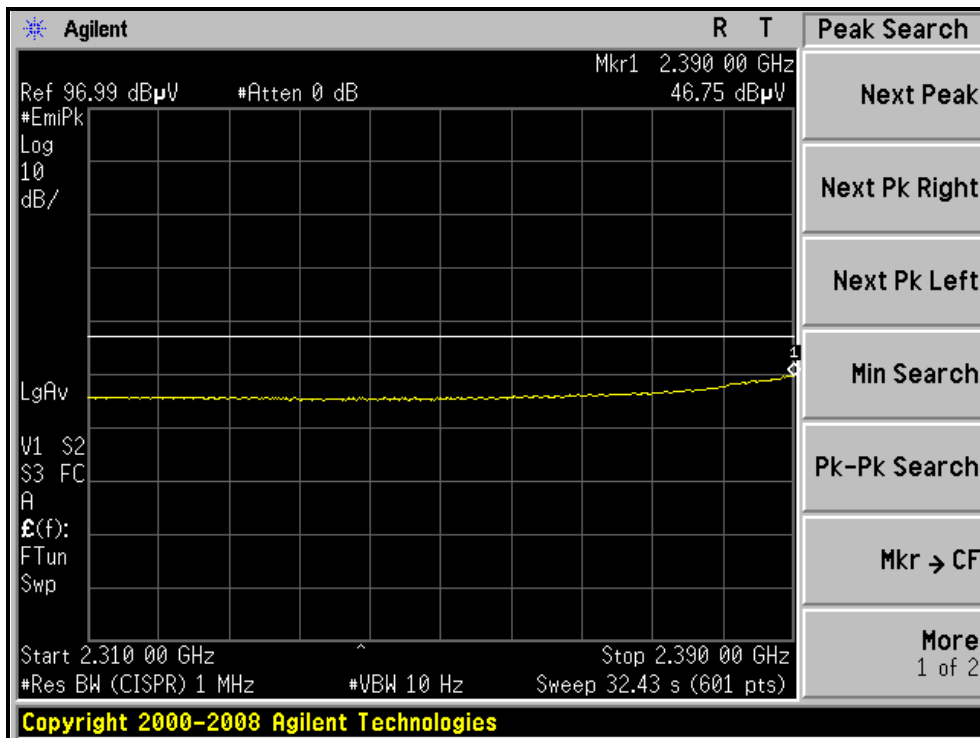
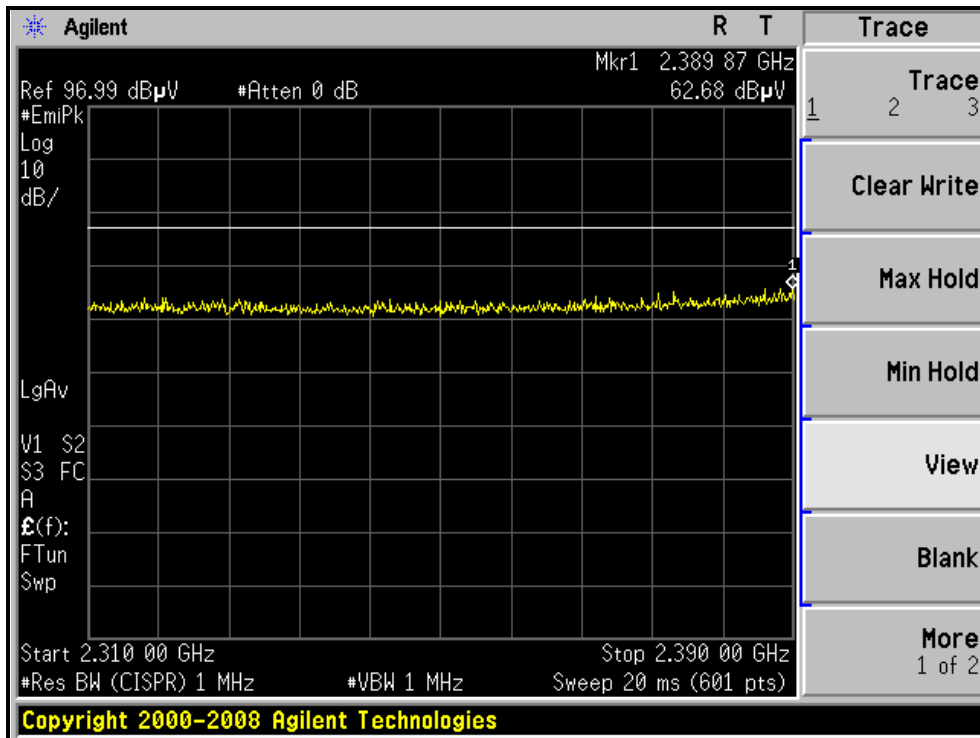



A D T

RESTRICTED BANDEDGE (802.11n (40MHz) MODE,CH1, VERTICAL )

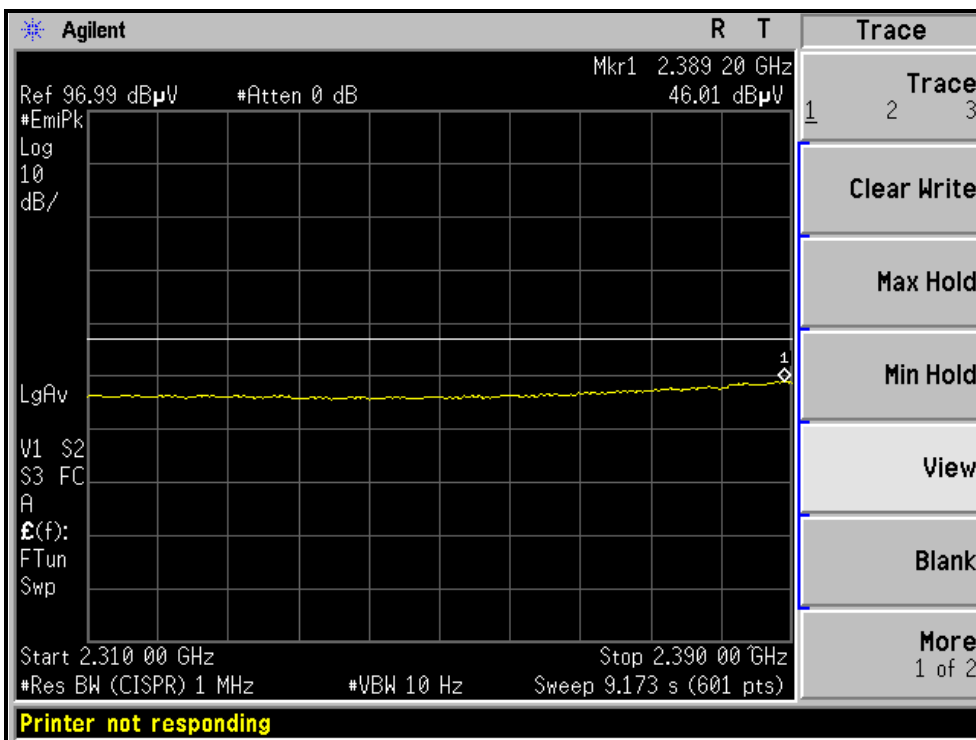
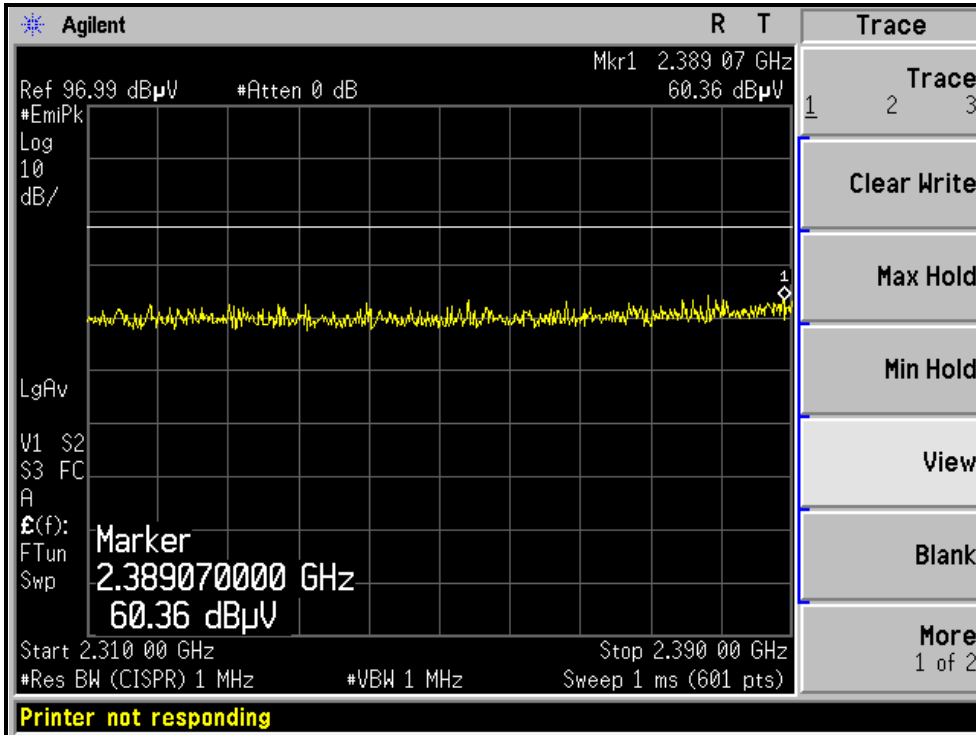



A D T

RESTRICTED BANDEDGE (802.11n (40MHz) MODE,CH7, HORIZONTAL )

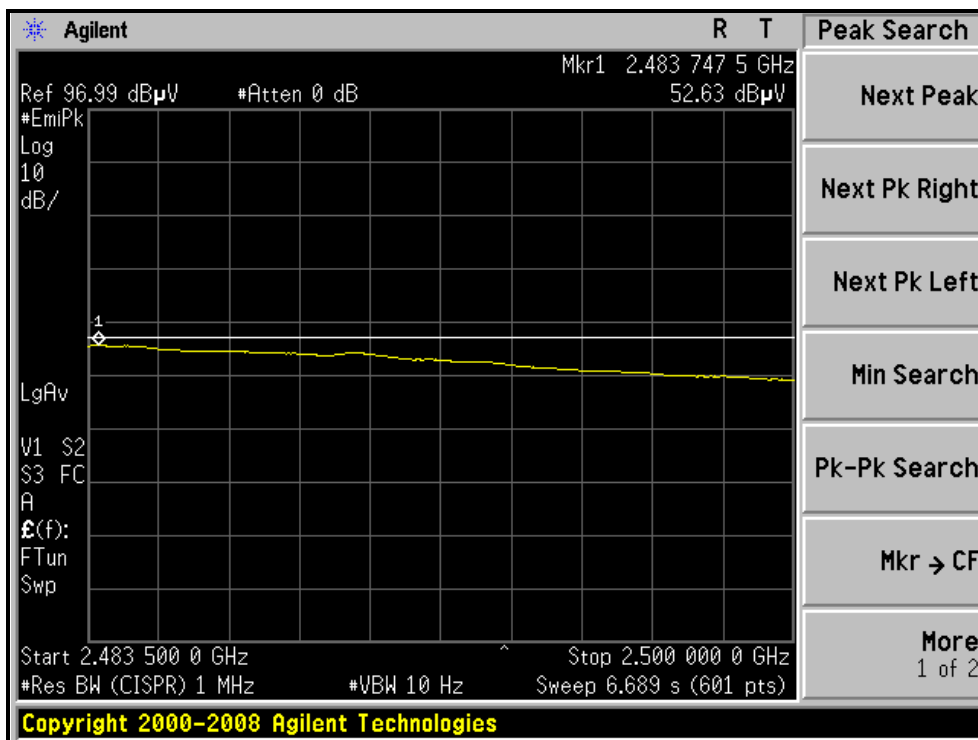
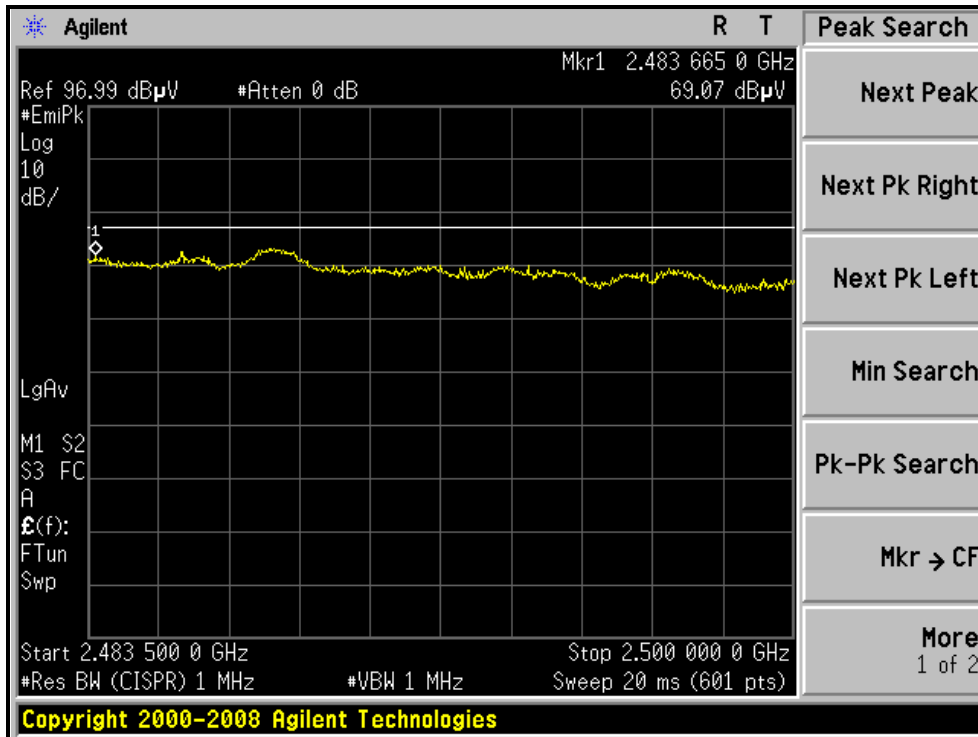





A D T

RESTRICTED BANDEDGE (802.11n (40MHz) MODE,CH7, VERTICAL )

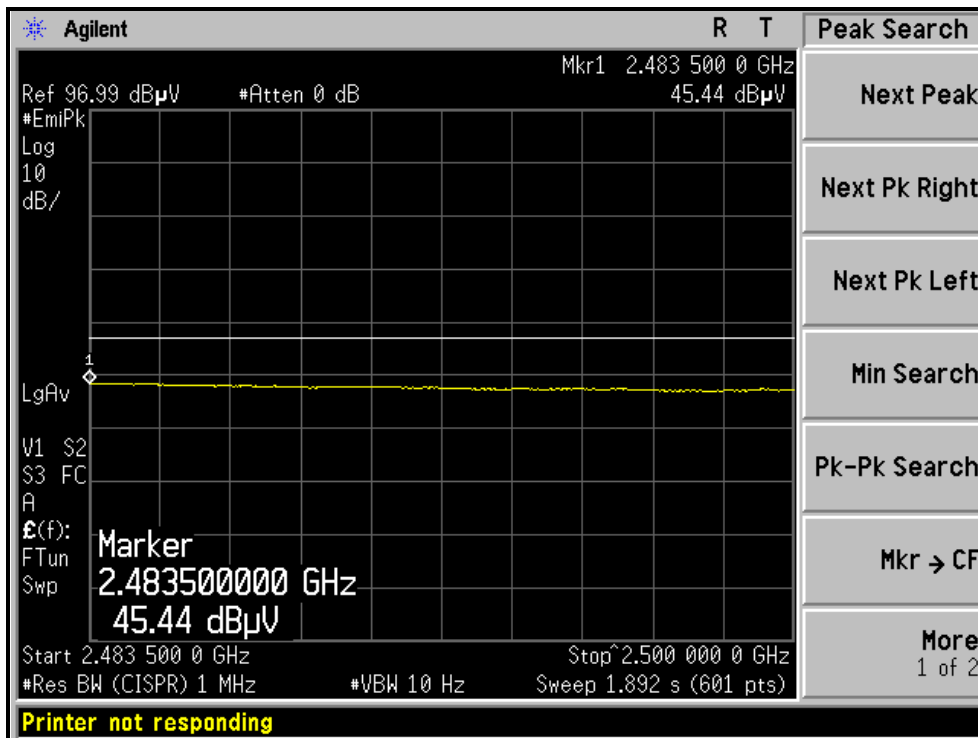
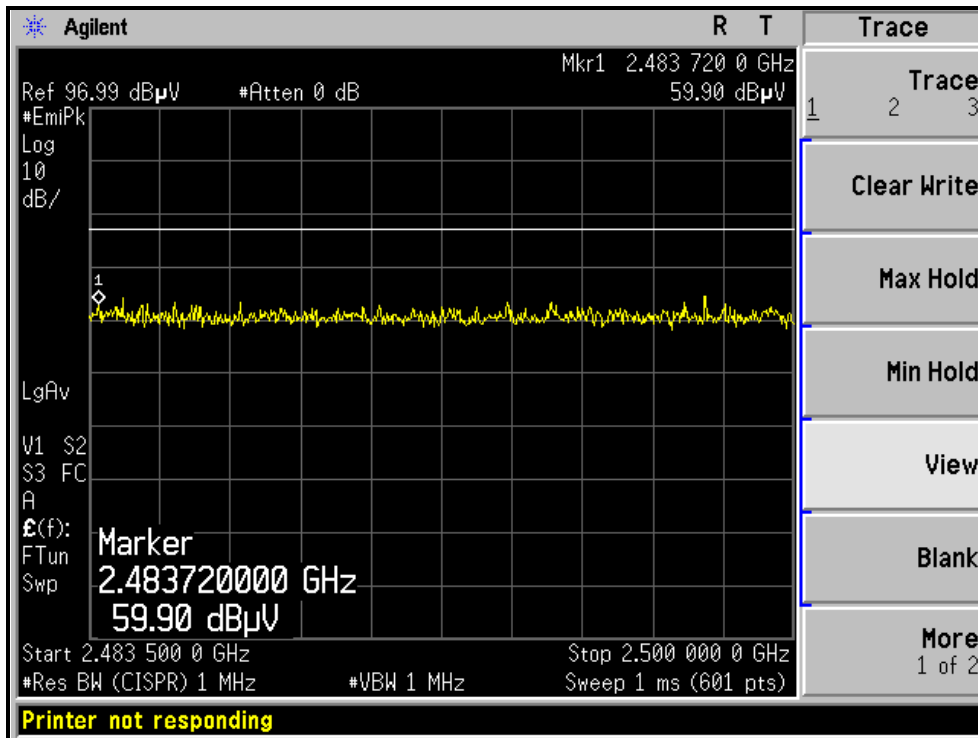

### 4.3 6dB BANDWIDTH MEASUREMENT

#### 4.3.1 LIMITS OF 6dB BANDWIDTH MEASUREMENT

The minimum of 6dB Bandwidth Measurement is 0.5 MHz.

#### 4.3.2 TEST INSTRUMENTS

DESCRIPTION & MANUFACTURER	MODEL NO.	SERIAL NO.	CALIBRATED DATE	CALIBRATED UNTIL
R&S SPECTRUM ANALYZER	FSP40	100037	Aug. 03, 2009	Aug. 02, 2010

**NOTE:**

- 1.The calibration interval of the above test instruments is 12 months and the calibrations are traceable to NML/ROC and NIST/USA.

#### 4.3.3 TEST PROCEDURE

The transmitter output was connected to the spectrum analyzer through an attenuator. The bandwidth of the fundamental frequency was measured by spectrum analyzer with 100kHz RBW and 100kHz VBW. The 6dB bandwidth is defined as the total spectrum the power of which is higher than peak power minus 6dB.

#### 4.3.4 DEVIATION FROM TEST STANDARD

No deviation

#### 4.3.5 TEST SETUP

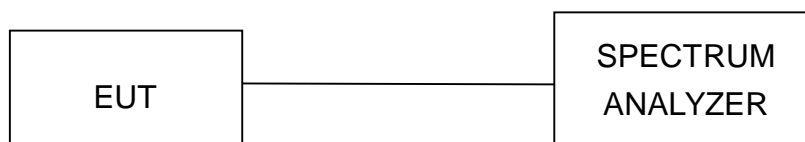

#### 4.3.6 EUT OPERATING CONDITIONS

The software provided by client to enable the EUT under transmission condition continuously at lowest, middle and highest channel frequencies individually.



A D T

### 4.3.7 TEST RESULTS

#### 802.11b DSSS MODULATION:

CHANNEL	CHANNEL FREQUENCY (MHz)	6dB BANDWIDTH (MHz)	MINIMUM LIMIT (MHz)	PASS / FAIL
1	2412	10.10	0.5	PASS
6	2437	10.09	0.5	PASS
11	2462	10.12	0.5	PASS

CH11

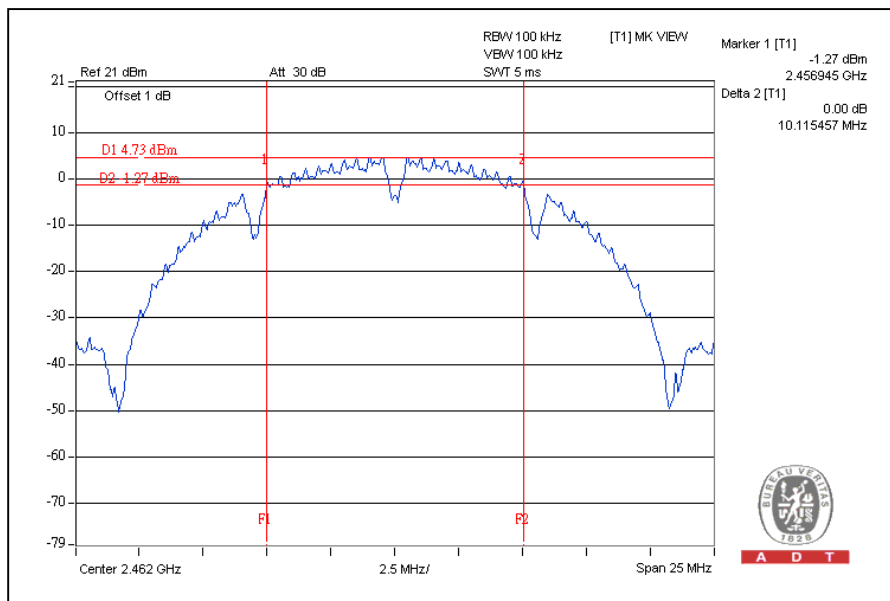



A D T

### 802.11g OFDM MODULATION:

CHANNEL	CHANNEL FREQUENCY (MHz)	6dB BANDWIDTH (MHz)	MINIMUM LIMIT (MHz)	PASS / FAIL
1	2412	16.52	0.5	PASS
6	2437	16.55	0.5	PASS
11	2462	16.57	0.5	PASS

### CH11

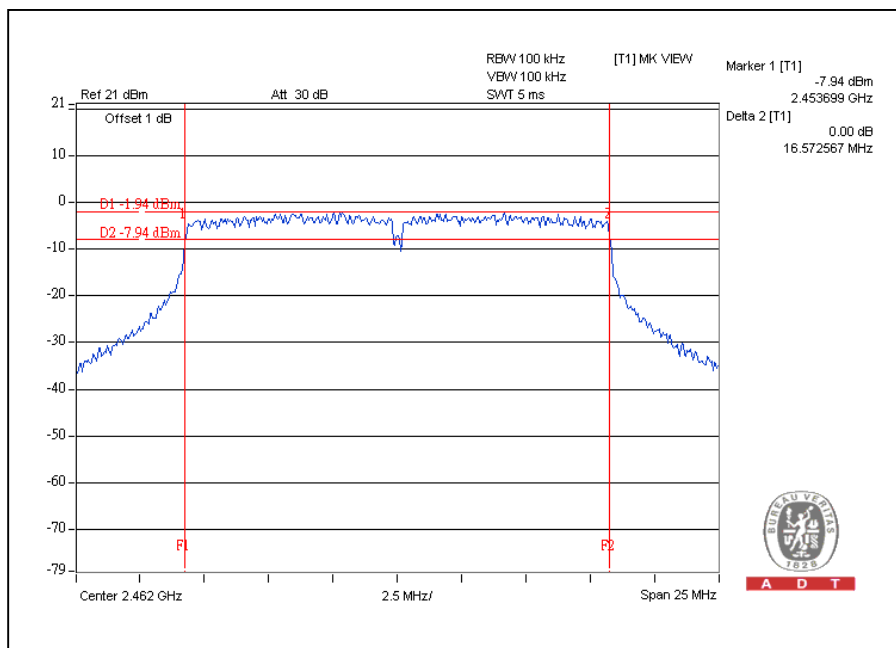





#### 4.4 MAXIMUM PEAK OUTPUT POWER

##### 4.4.1 LIMITS OF MAXIMUM PEAK OUTPUT POWER MEASUREMENT

The Maximum Peak Output Power Measurement is 30dBm.

##### 4.4.2 INSTRUMENTS

DESCRIPTION & MANUFACTURER	MODEL NO.	SERIAL NO.	CALIBRATED DATE	CALIBRATED UNTIL
Anritsu Power Meter	ML2495A	0824006	April 25, 2009	April 24, 2010
Pulse Power Sensor	MA2411B	0738172	April 25, 2009	April 24, 2010

**NOTE:**

The calibration interval of the above test instruments is 12 months and the calibrations are traceable to NML/ROC and NIST/USA.

##### 4.4.3 TEST PROCEDURES

1. The transmitter output was connected to the power meter through an attenuator; the bandwidth of the fundamental frequency was measured with the power meter.
2. Record the power level.

##### 4.4.4 DEVIATION FROM TEST STANDARD

No deviation

##### 4.4.5 TEST SETUP

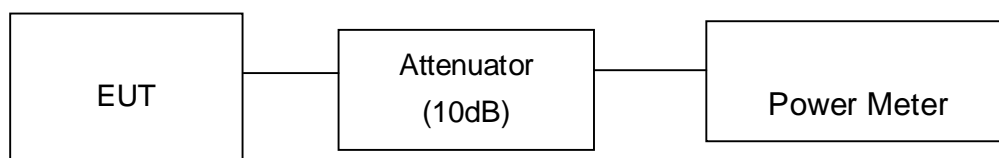

##### 4.4.6 EUT OPERATING CONDITIONS

Same as Item 4.3.6



#### 4.4.7 TEST RESULTS

##### 802.11b DSSS MODULATION:

CHANNEL	CHANNEL FREQUENCY (MHz)	PEAK POWER OUTPUT (dBm)	PEAK POWER OUTPUT (mW)	PEAK POWER LIMIT (dBm)	PASS / FAIL
1	2412	20.3	107.2	30	PASS
6	2437	19.3	85.1	30	PASS
11	2462	17.8	60.3	30	PASS

##### 802.11g OFDM MODULATION:

CHANNEL	CHANNEL FREQUENCY (MHz)	PEAK POWER OUTPUT (dBm)	PEAK POWER OUTPUT (mW)	PEAK POWER LIMIT (dBm)	PASS / FAIL
1	2412	24.0	251.2	30	PASS
6	2437	23.2	208.9	30	PASS
11	2462	21.8	151.4	30	PASS

##### 802.11n (20MHz) OFDM MODULATION:

CHANNEL	CHANNEL FREQUENCY (MHz)	PEAK POWER OUTPUT (dBm)	PEAK POWER OUTPUT (mW)	PEAK POWER LIMIT (dBm)	PASS / FAIL
1	2412	24.0	251.2	30	PASS
6	2437	23.2	208.9	30	PASS
11	2462	22.2	166.0	30	PASS





A D T

**802.11n (40MHz) OFDM MODULATION:**

CHANNEL	CHANNEL FREQUENCY (MHz)	PEAK POWER OUTPUT (dBm)	PEAK POWER OUTPUT (mW)	PEAK POWER LIMIT (dBm)	PASS / FAIL
1	2422	22.5	177.8	30	PASS
4	2437	21.9	154.9	30	PASS
7	2452	21.9	154.9	30	PASS

## 4.5 POWER SPECTRAL DENSITY MEASUREMENT

### 4.5.1 LIMITS OF POWER SPECTRAL DENSITY MEASUREMENT

The Maximum of Power Spectral Density Measurement is 8dBm.

### 4.5.2 TEST INSTRUMENTS

DESCRIPTION & MANUFACTURER	MODEL NO.	SERIAL NO.	CALIBRATED DATE	CALIBRATED UNTIL
R&S SPECTRUM ANALYZER	FSP40	100037	Aug. 03, 2009	Aug. 02, 2010

**NOTE:**

- 1.The calibration interval of the above test instruments is 12 months and the calibrations are traceable to NML/ROC and NIST/USA.

### 4.5.3 TEST PROCEDURE

The transmitter output was connected to the spectrum analyzer through an attenuator, the bandwidth of the fundamental frequency was measured with the spectrum analyzer using 3kHz RBW and 30kHz VBW , set sweep time = span/3kHz. The power spectral density was measured and recorded. The sweep time is allowed to be longer than span/3kHz for a full response of the mixer in the spectrum analyzer.

### 4.5.4 DEVIATION FROM TEST STANDARD

No deviation

### 4.5.5 TEST SETUP

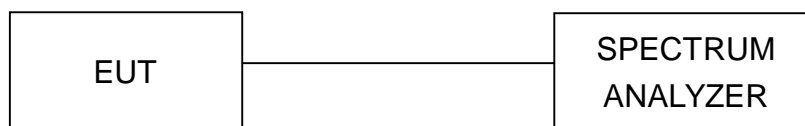

### 4.5.6 EUT OPERATING CONDITION

Same as Item 4.3.6



A D T

### 4.5.7 TEST RESULTS

#### 802.11b DSSS MODULATION:

CHANNEL	CHANNEL FREQUENCY (MHz)	RF POWER LEVEL IN 3kHz BW (dBm)	MAXIMUM LIMIT (dBm)	PASS / FAIL
1	2412	-11.6	8	PASS
6	2437	-11.3	8	PASS
11	2462	-11.2	8	PASS

#### CH11

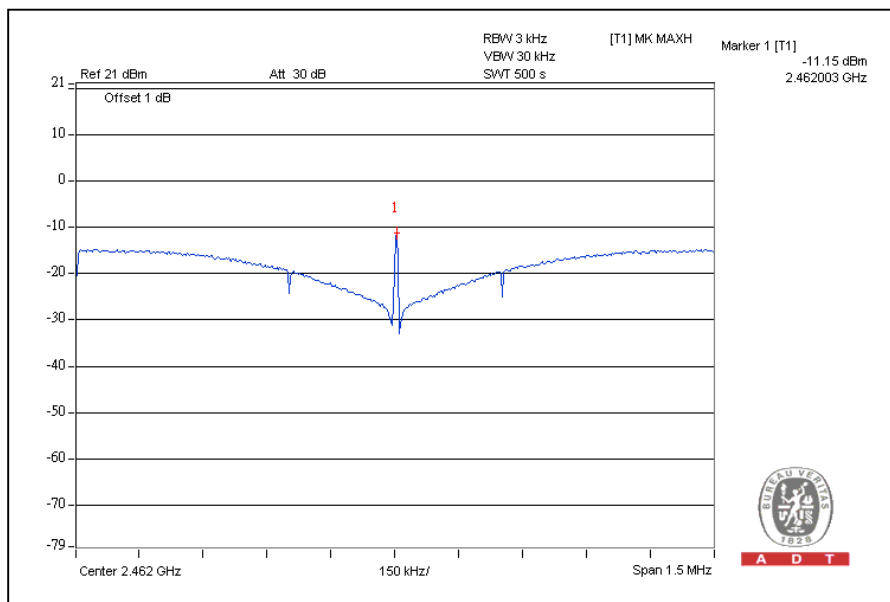



A D T

### 802.11g OFDM MODULATION:

CHANNEL	CHANNEL FREQUENCY (MHz)	RF POWER LEVEL IN 3kHz BW (dBm)	MAXIMUM LIMIT (dBm)	PASS / FAIL
1	2412	-11.1	8	PASS
6	2437	-12.2	8	PASS
11	2462	-11.6	8	PASS

CH1

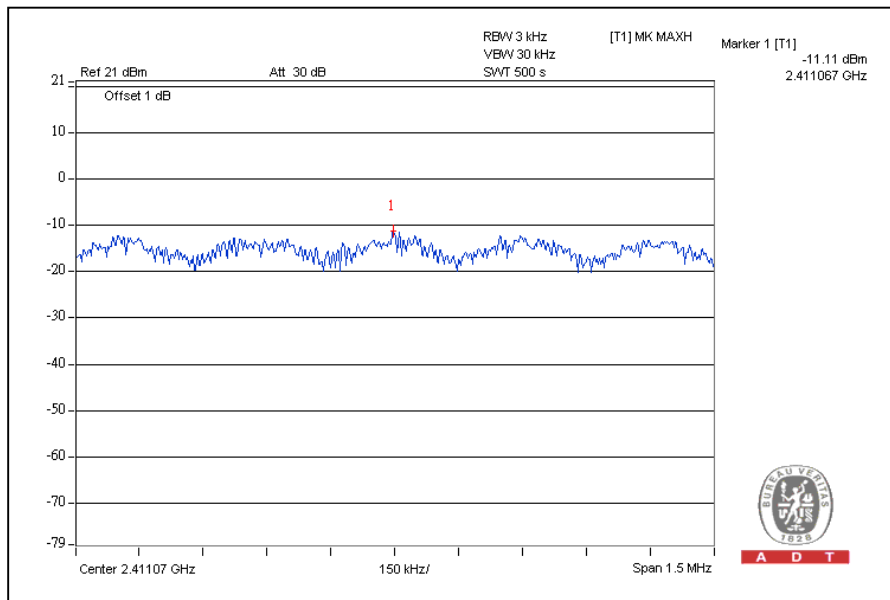



A D T

### 802.11n (20MHz) OFDM MODULATION:

CHANNEL	CHANNEL FREQUENCY (MHz)	RF POWER LEVEL IN 3kHz BW (dBm)	MAXIMUM LIMIT (dBm)	PASS / FAIL
1	2412	-10.1	8	PASS
6	2437	-11.9	8	PASS
11	2462	-11.5	8	PASS

CH1

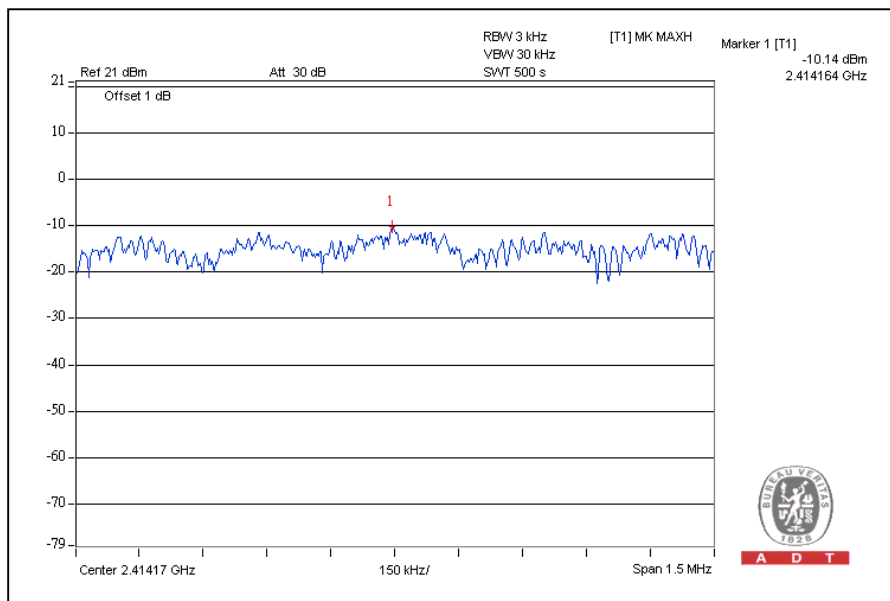



A D T

### 802.11n (40MHz) OFDM MODULATION:

CHANNEL	CHANNEL FREQUENCY (MHz)	RF POWER LEVEL IN 3kHz BW (dBm)	MAXIMUM LIMIT (dBm)	PASS / FAIL
1	2422	-12.2	8	PASS
4	2437	-12.1	8	PASS
7	2452	-11.9	8	PASS

CH7

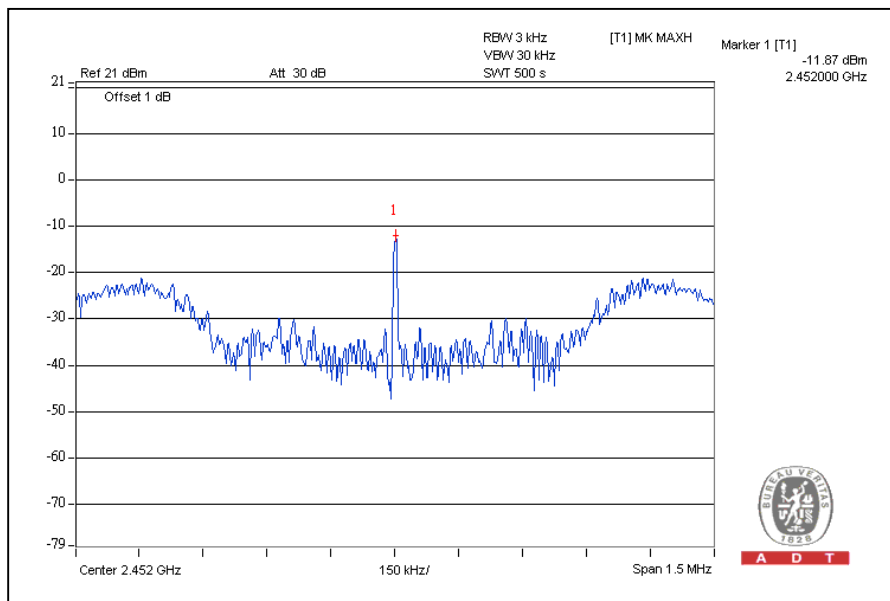

A D T

## 4.6 CONDUCTED OUT-BAND EMISSION MEASUREMENT

### 4.6.1 LIMITS OF CONDUCTED OUT-BAND EMISSION MEASUREMENT

Below  $-20\text{dB}$  of the highest emission level of operating band (in 100kHz Resolution Bandwidth).

### 4.6.2 TEST INSTRUMENTS

DESCRIPTION & MANUFACTURER	MODEL NO.	SERIAL NO.	CALIBRATED DATE	CALIBRATED UNTIL
R&S SPECTRUM ANALYZER	FSP40	100037	Aug. 03, 2009	Aug. 02, 2010

#### NOTE:

- The calibration interval of the above test instruments is 12 months and the calibrations are traceable to NML/ROC and NIST/USA.

### 4.6.3 TEST PROCEDURE

The transmitter output was connected to the spectrum analyzer via a low loss cable. Set RBW of spectrum analyzer to 100kHz and VBW of spectrum analyzer to 300kHz with suitable frequency span including 100 MHz bandwidth from band edge. The band edges was measured and recorded.

The spectrum plots (RBW = 100kHz, VBW = 300kHz) are attached on the following pages.

### 4.6.4 DEVIATION FROM TEST STANDARD

No deviation

### 4.6.5 EUT OPERATING CONDITION

Same as Item 4.3.6

### 4.6.6 TEST RESULTS

The spectrum plots are attached on the following images. D1 line indicates the highest level, and D2 line indicates the 20dB offset below D1. It shows compliance with the requirement in part 15.247(d).

## 802.11b DSSS MODULATION:

### CH1

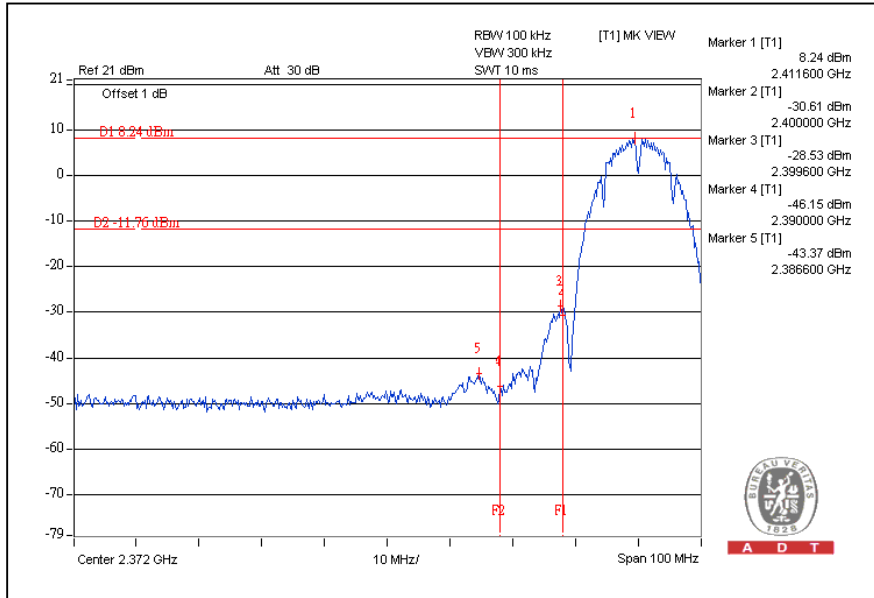

### CH11

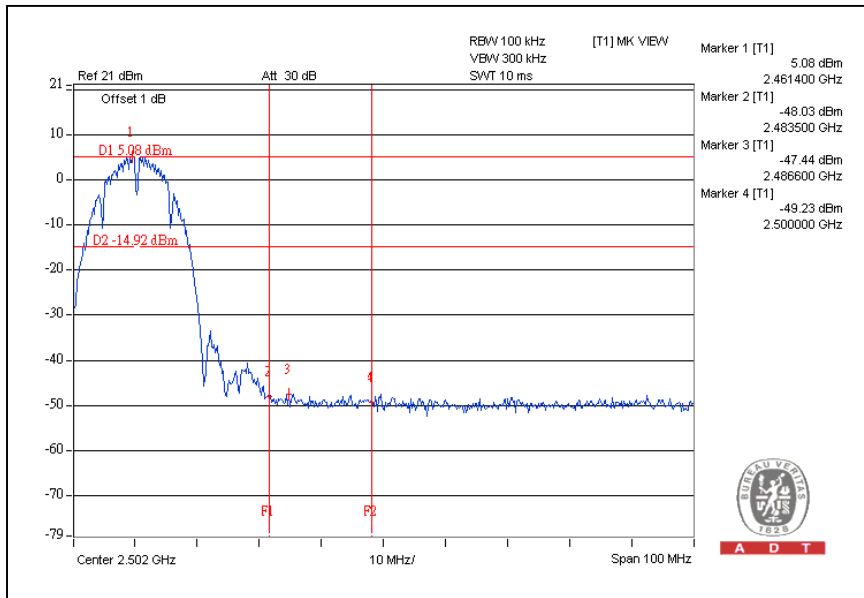





A D T

### CH1

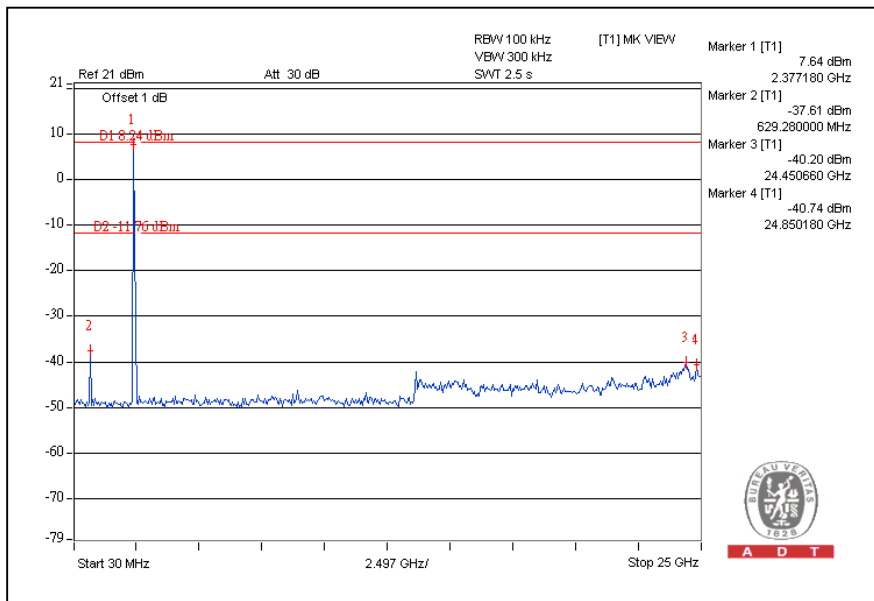

### CH11

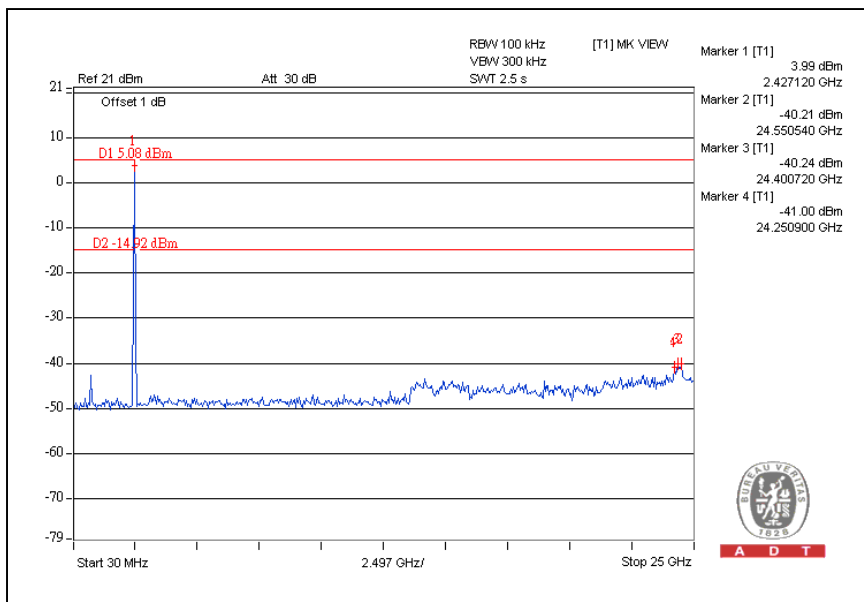

### 802.11g OFDM MODULATION:

#### CH1

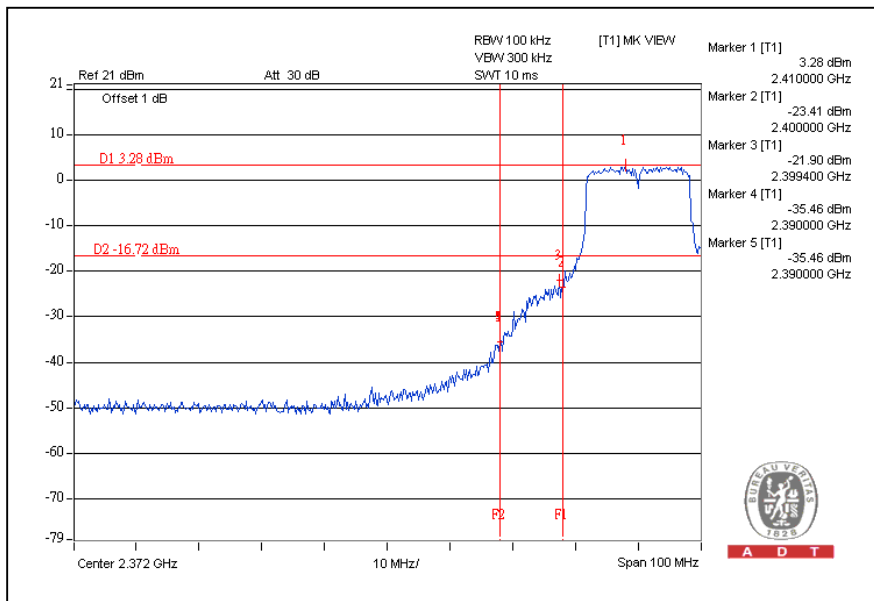

#### CH11

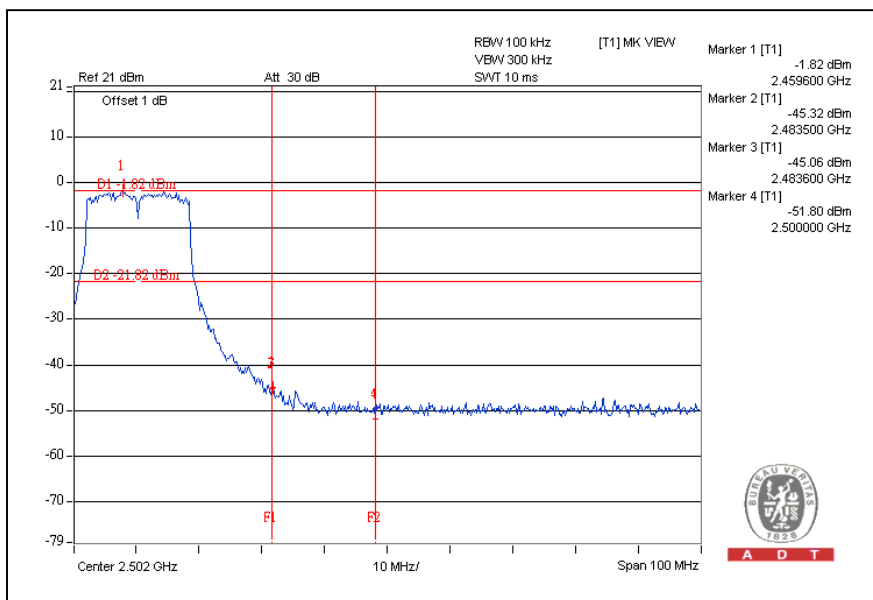



A D T

### CH1

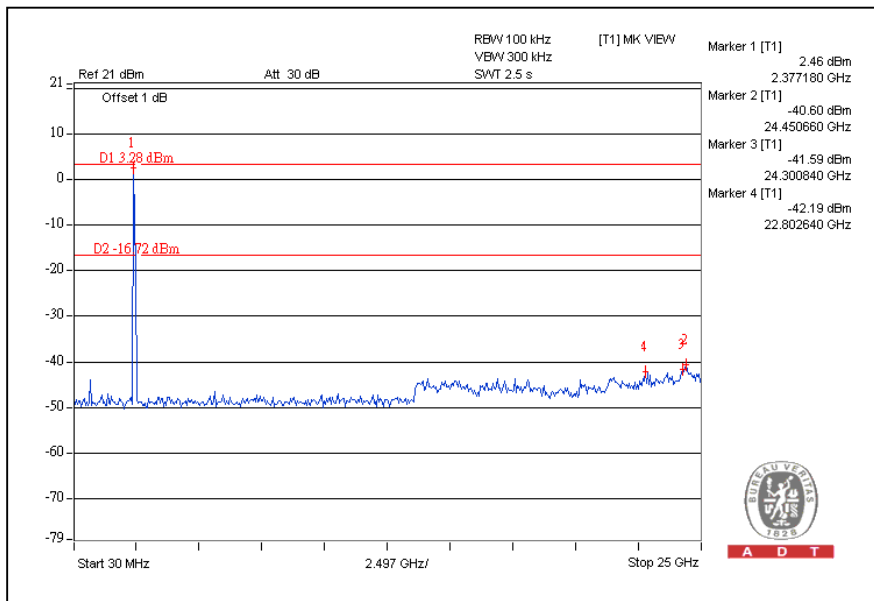

### CH11

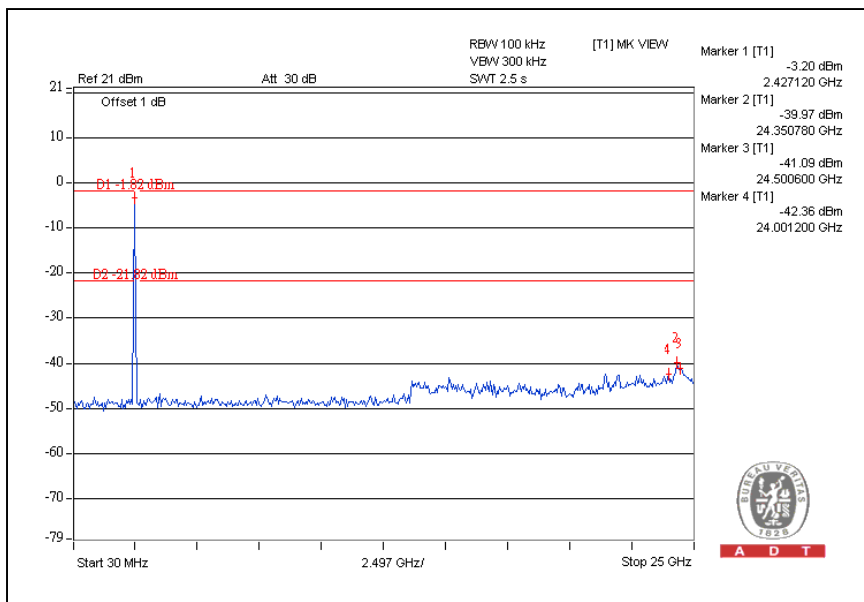

### 802.11n (20MHz) OFDM MODULATION:

CH1

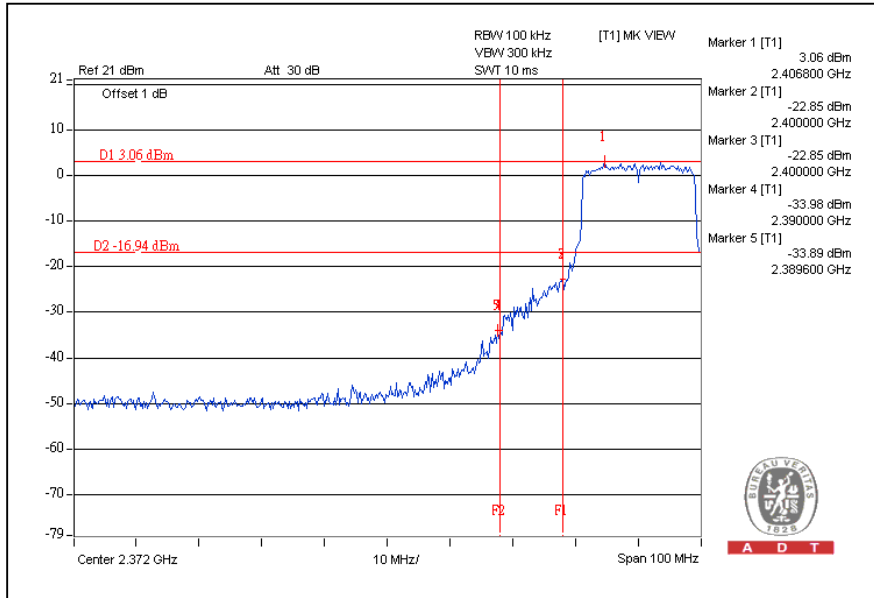

CH11

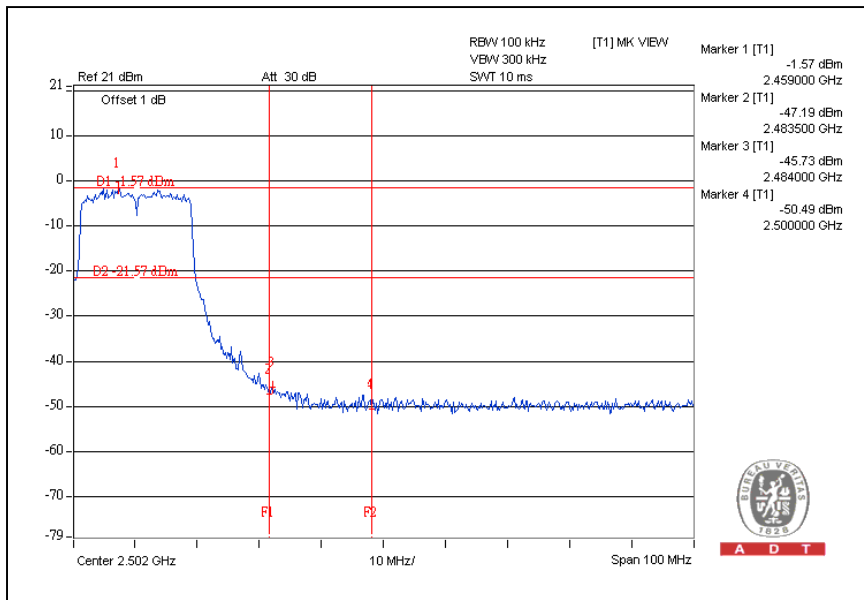



A D T

### CH1

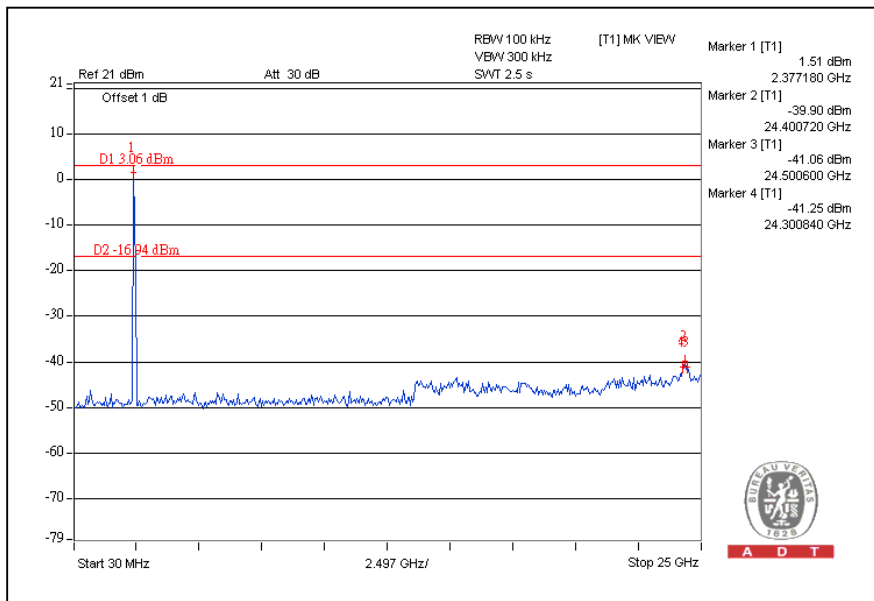

### CH11

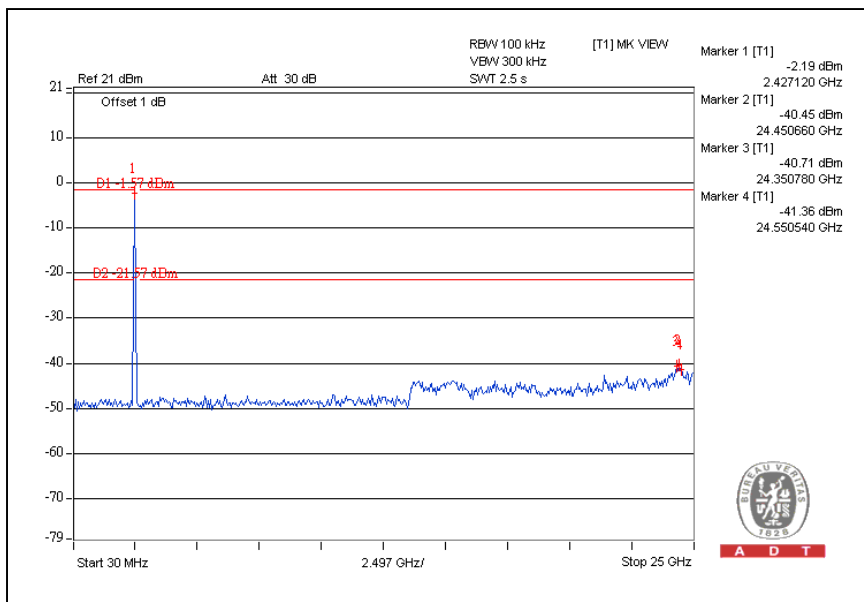

## 802.11n (40MHz) OFDM MODULATION:

### CH1

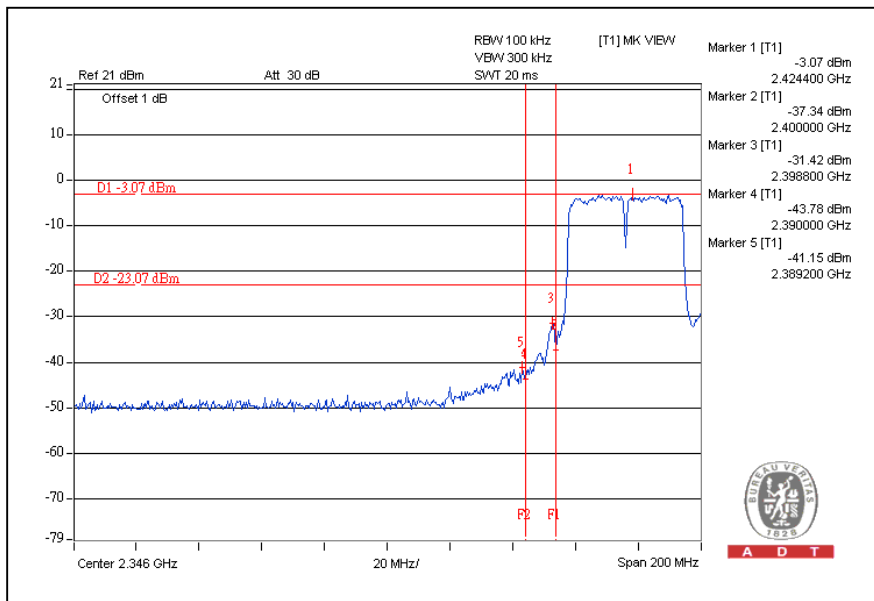

### CH7

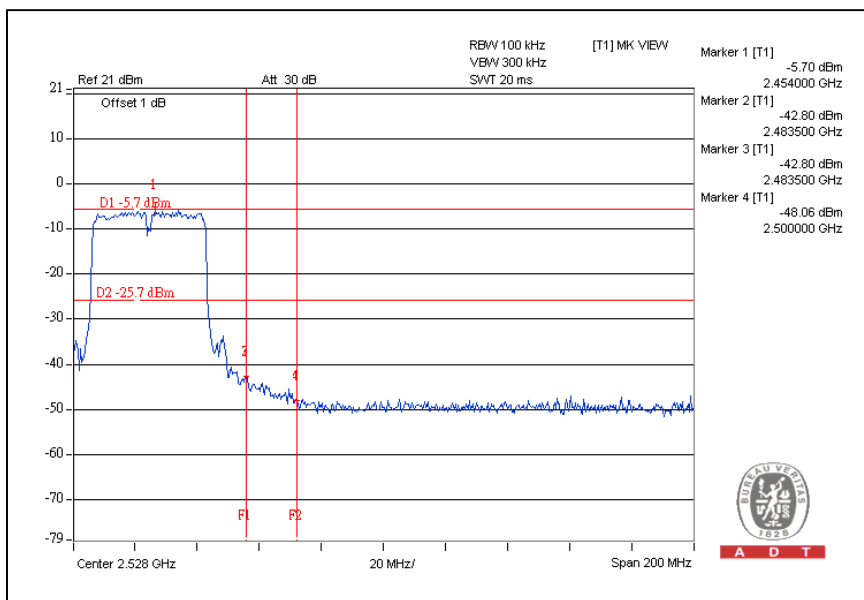



A D T

### CH1

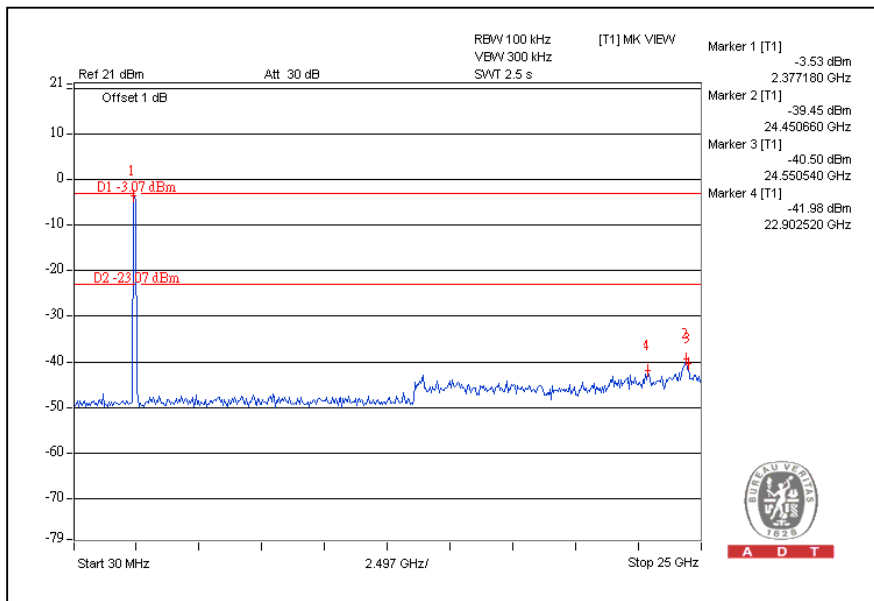

### CH7

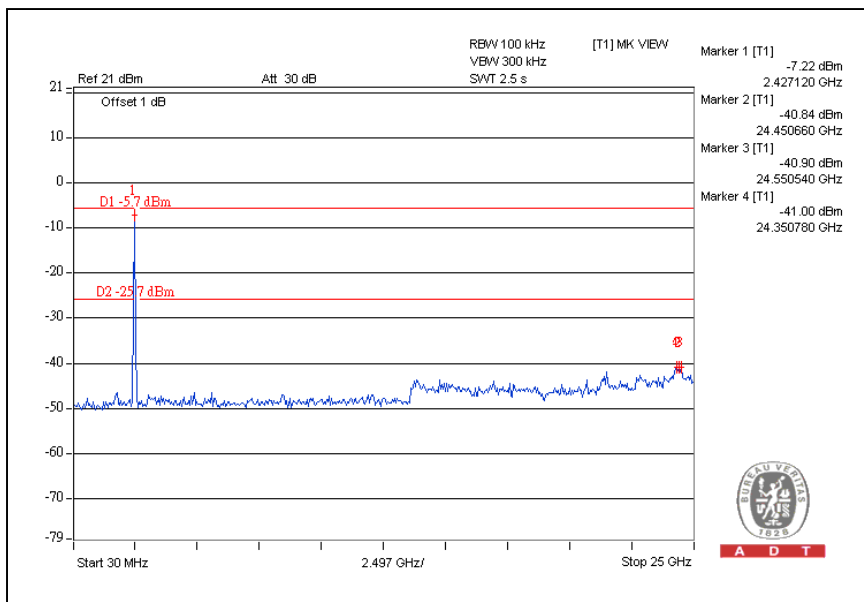



## 5. INFORMATION ON THE TESTING LABORATORIES

We, Bureau Veritas Consumer Products Services (H.K.) Ltd., Taoyuan Branch, were founded in 1988 to provide our best service in EMC, Radio, Telecom and Safety consultation. Our laboratories are accredited and approved according to ISO/IEC 17025:

Copies of accreditation certificates of our laboratories obtained from approval agencies can be downloaded from our web site: [www.adt.com.tw/index.5/phtml](http://www.adt.com.tw/index.5/phtml). If you have any comments, please feel free to contact us at the following:

**Linko EMC/RF Lab:**

Tel: 886-2-26052180

Fax: 886-2-26052943

**Hsin Chu EMC/RF Lab:**

Tel: 886-3-5935343

Fax: 886-3-5935342

**Hwa Ya EMC/RF/Safety/Telecom Lab:**

Tel: 886-3-3183232

Fax: 886-3-3185050

**Email:** [service@adt.com.tw](mailto:service@adt.com.tw)

**Web Site:** [www.adt.com.tw](http://www.adt.com.tw)

The address and road map of all our labs can be found in our web site also.





A D T

## **6.APPENDIX A - MODIFICATIONS RECORDERS FOR ENGINEERING CHANGES TO THE EUT BY THE LAB**

No any modifications are made to the EUT by the lab during the test.

**--- END ---**