

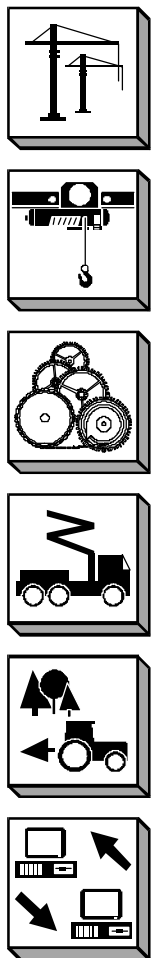

HBC – Radio Control

PM NTU Radio Transmitter

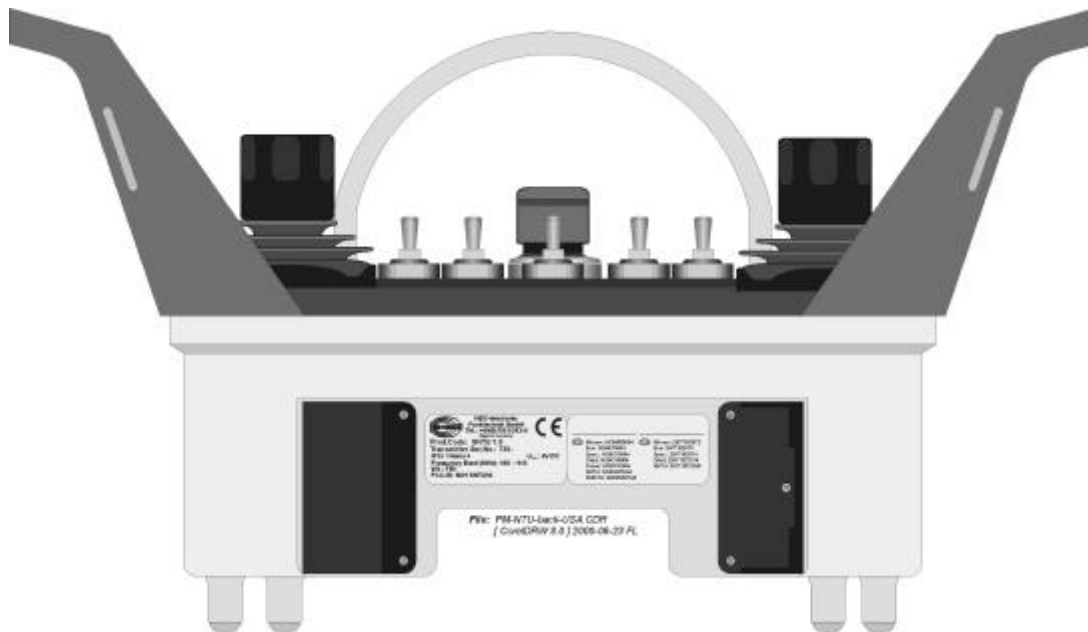



Operating Instructions *PM NTU Radio Transmitter*

Manufactured by : HBC-radiomatic GmbH
Haller Strasse 49 - 53
74564 Crailsheim • GERMANY
Telephone : +49 (0) 79 51 - 3 93 - 0
Fax : +49 (0) 79 51 - 3 93 - 50
E-mail : info@radiomatic.com
<http://www.hbc-radiomatic.com>

Distributed by : HBC-radiomatic, Inc.
4480 Lake Forest Drive, Suite 306
Cincinnati, OH 45242, USA
Telephone : (513) - 7 33 - 49 00
Fax : (513) - 7 33 - 49 03

HBC-radiomatic GmbH is not liable for any misprints or errors! – All rights reserved.

™ *HBC-radiomatic* is a registered American trademark.

© 2001 – 07 , HBC-radiomatic GmbH , 74564 Crailsheim , Germany

No part of any software or of the present document may be reproduced in any manner whatsoever without the expressed written permission of HBC-radiomatic GmbH.



Table of Contents

1	Description	4
2	Safety Instructions.....	5
2.1	Pictographs	5
2.2	General Safety Instructions.....	6
2.3	Operator Safety Instructions	7
3	Operating Instructions	8
	User Defined Teaching	9
3.1	Battery and Battery Charger	10
3.1.1	FuB 10 AA Transmitter Battery	10
3.1.2	FLG 102 Battery Charger.....	10
3.2	Special Operating Modes (Optional).....	11
3.2.1	Scanner (Frequency Selection) Option.....	11
3.2.2	Cable Control Option.....	12
4	Trouble-Shooting	13
5	Maintenance.....	14
5.1	In The Event of a Fault	14
6	Technical Data	15
6.1	Dimensions of the PM NTU	16



1 Description

The PM NTU transmitter is designed to transmit command instructions for controlling construction, industrial and mobile cranes, hoists and machines.

Depending on the type and version selected, up to 32 digital or 8 analog + 24 digital control commands plus the integrated safety commands are available to the operator.

A non-interchangeable system address ensures the functional safety of the radio control system when operating cranes or machines. This feature is particularly important when several cranes or machines are in use, for example in halls and shops. The system address is exclusively allocated to each HBC radio transmitter and its respective receiver.

It is not possible to activate crane or machine functions using a radio control system allocated to another crane or machine.

The transmitter has general telecommunications approvals. It is not necessary to have or to apply for a license to operate the transmitter with the respective receiver. The transmitter broadcasts in either a 30 cm or 70 cm bandwidth. The transmitter is equipped with < 10 mW transmitting power.

Operating the PM NTU transmitter using a different frequency range or transmitting power requires the approval of the competent regulative authorities for telecommunication.

The radio control system consists of the PM NTU transmitter, two rechargeable NiCd batteries, a battery charger and a receiver with antenna. The transmitter housing with integrated antenna is made of glass-fiber reinforced plastic.

State of the art radio technology complying with the latest guidelines of the FCC and the use of highly developed microprocessor technology guarantees optimal operating safety, availability and longevity.

The following radio receivers may be used in conjunction with the PM NTU transmitter:

- FSE 722 B
- FSE 735
- FSE 770



Note :

The improper use, operation or deployment of the device renders the manufacturer guarantee void of any legal substance !

2 Safety Instructions

2.1 Pictographs

The following pictographs will be used throughout the present operating instructions :



Indicates a possible shock hazard

Contacting components under voltage may lead to death. Housing (e. g. hoods and lids) marked with this symbol may only be opened by qualified electricians after having disconnected the device from the mains supply (supply voltage, operating voltage or input terminal voltage).



Indicates safety relevant passages

You will find this pictograph as an indicator for occupational safety measures. The neglecting of such measures poses a serious hazard.

Always observe the instructions and be particularly attentive and careful.

Avoid any situations that could at any time be a danger to persons or machines.



Indicates important information

This symbol brings your attention to important information on how to secure a long serviceable life of the radio control system.

Pay attention to the comments and instructions given. Ignoring the information provided may permanently impair the reliability and operability of the equipment.



2.2 General Safety Instructions

Radio controls facilitate and increase the operating efficiency of construction cranes. Nevertheless, the operator must thoroughly understand and be in a position to properly use a radio control system !



Important information :

Modifications made to this device, not expressly approved by the manufacturer may void the users authority to operate this device !

- Read the Operating Instructions Manual carefully and thoroughly before working with the radio transmitter for the first time !
- The operator undertakes to strictly adhere to the instructions and proceedings described in this manual, as well as to follow the general rules and regulations for worker safety and accident prevention. Ignoring any such instructions or regulations could pose a fatal threat to the operator or others.
- Keep this manual on location and readily available at all times !
- Only authorized and properly trained personnel may operate the radio transmitter.
- Anyone who is under the influence of drugs, alcohol or medication that has a negative effect on a person's reactions may at no time commission, operate, maintain or repair the radio transmitter.
- Before switching the radio transmitter ON ensure that no-one is or can be endangered by the initiated operation.
- With the first signs of any malfunction related to the operative safety and reliability of the PM NTU radio transmitter, the operator must immediately shut down or not activate the transmitter. For the purpose of the present manual "shut down" implies :
 - switching OFF the transmitter,
 - storing the transmitter in a safe place and ensuring no unauthorized access,
 - de-energizing the receiver and
 - unplugging the connection cable on the receiver !
- Defects must be repaired and objects of interference must be removed immediately !
- Only qualified and competent personnel are permitted to repair a defective transmitter. Use original HBC spare parts only ! The use of any other spares will render the technical inspectorate approval invalid as well as substantially impede operative safety.
- Observe all periodical tests and inspections that are required by law or recommended in the present operating instructions !
- When using the PM NTU radio transmitter always observe the regulations and instructions stipulated in the authoritative worker's safety and accident prevention regulations (e.g. VBG 9).
 - The PM NTU radio transmitter has been manufactured in accordance with the regulations and guidelines stipulated in the German Trade Association's "Safety and Accident Prevention Regulations for Operating Cranes by Radio Controls" (VBG 9) and pr EN 12077-1.
 - The PM NTU radio transmitter has been tested and approved in accordance with EMC guidelines and complies with the authoritative standards for emitted interference and interference immunity.
- Use the transmitter carefully and solely for its intended use. In particular when using a transmitter to radio control a crane for the first time.



2.3 Operator Safety Instructions

- Before beginning crane operation, position yourself so that you have a clear and complete overview of the working radius of the crane or machine.
- Depending on your angle or position to the crane or machine, the transmitter control commands “trolley left” and “trolley right” appear to interchange! It is essential that you take your bearings to the crane or machine into due consideration before operating equipment.
- In case of an emergency or any disturbances within the working range of the crane or machine, switch the transmitter off immediately by the STOP button. Should the transmitter show signs of technical failure or breakdown, disconnect the radio control system immediately !
- Always switch OFF the transmitter during breaks and after finishing work to avoid operating errors or any accidental actuation of operator control elements.
 - These precautions are particularly important whenever changing your position or climbing over an obstacle.
- Never leave an activated transmitter unattended. The operator undertakes to follow and comply with the authoritative regulations for worker safety and accident prevention (e. g. VBG 9).



Note :

- In the event of an interruption of the radio link during a working cycle – what can occasionally happen – both transmitter and receiver automatically shut down (so-called "**compulsory switch-off**").
To reactivate the system release all operator controls, such as pushbuttons or momentary contacts, and allow the control elements to return to their zero position. Reactivate the radio control system by pressing the "ON/OFF" toggle switch. The system must be reactivated before the crane or machine can react to control commands ! This feature hinders any uncontrolled or unwanted crane or machine movement, should the radio link be interrupted.
- When operating a crane by means of a radio control system for the first time, you may miss the physical contact to the crane that you were used to in the operating stand. As you are no longer in the crane and can no longer sense the starting of the crane movements as distinctly, crane reactions will appear sluggish or dull.



3 Operating Instructions

1. Before commissioning the transmitter or initial operation, insert a fully charged FuB 10 AA battery into battery compartment (pos. ①) at the back of the transmitter (inscription must be visible). The battery supplies the necessary working voltage (6 V DC).
2. Turn STOP button (pos. ②) to the right to unlock.
3. Switch ON transmitter and crane or machine with "ON/OFF" toggle switch (pos. ③).
The **green LED** (pos. ④) begins to flash, i.e. the transmitter is operable.



Important information :

After switching ON the transmitter and **before** operating the crane or machine you must always :

- trigger the acoustic signal by pressing the "Horn" pushbutton (pos. ⑥). This warns all colleagues that the crane or machine is about to move;
- test the operativeness of the STOP button.

After switching ON the transmitter the instrument indicates a successful radio link to the receiver when the red LED "RF/H.F./AF/RF" extinguishes and the green LED "Si 1" lights up (refer to control light panel on receiver). The radio control system is ready for use. The operator can now issue control commands using the transmitter control elements.

When the battery is nearly empty, the **red LED** (pos. ⑤) lights up or an acoustic signal sounds. Replace the drained battery **immediately** and insert into the battery charger for recharging (refer to chapter "Battery and Battery Charger" for further details).

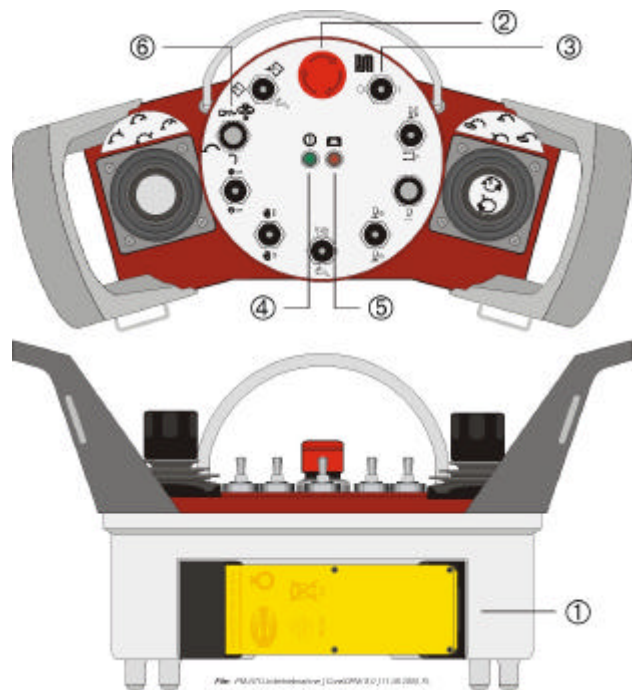

Note :

The transmitter will automatically switch OFF within a few minutes if the operator fails to replace the drained battery.

Should the operator – intentionally or unintentionally – switch off the transmitter with the STOP button, proceed as follows to re-start the transmitter :

1. Switch transmitter OFF with the "ON / OFF" toggle switch (pos. ③).
2. Turn STOP button (pos. ②) to the right to unlock;
3. Switch transmitter ON again with the "ON / OFF" toggle switch.



Note :

Always use the "ON / OFF" switch to switch the transmitter ON or OFF. Do not use the STOP button !

User Defined Teaching

Toggle Switch "Mast Speed Selection" (Pos. ①)

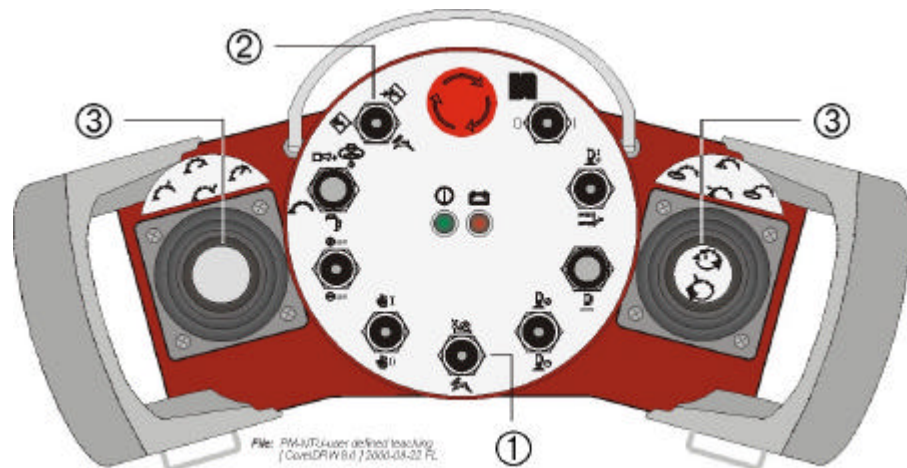

The toggle switch "mast speed selection" enables the operator to operate the mast with one of the factory-set motion rates. The mast can be operated at 100% speed in "rabbit" position and at 50% in "snail" position.

The momentary contact / toggle switch "set mast speed" (pos. ②) must be in "rabbit" position (lower position).



Momentary Contact / Toggle Switch "Set Mast Speed" (Pos. ②)

The momentary contact switch / toggle switch "set mast speed" has three different positions :

-  Set the toggle switch to this position to program operator-defined mast speeds.
-  Set the toggle switch to this position to operate the mast with operator-defined speeds.
-  Set the toggle switch to this position to operate the mast with factory-set speeds.

Setting Operator-Defined Mast Speeds

Each mast function must be set separately !

- Hold momentary contact toggle switch (pos. ②) in up position.
- Use joystick (pos. ③) to operate selected mast function at maximum speed and maximum excursion of the joy stick as is required for later use.
- Release momentary contact toggle switch and then joystick (observe sequence).

To operate mast functions at operator-defined speeds set toggle switch (pos. ②) to center position and actuate joystick at maximum excursion. The mast now moves at programmed speed. The rate of motion is proportionate to joystick excursion, i.e. reducing joystick excursion reduces mast speed.



3.1 Battery and Battery Charger

3.1.1 FuB 10 AA Transmitter Battery

The age and ambient temperature are decisive for the length of the battery charge. Older batteries lose capacity over time. Temperatures under zero also have a negative effect on battery charge.

The length of serviceable battery life depends on how the battery is treated. When handled properly the FuB 10 AA battery can exceed 500 charging cycles. Do not totally discharge or short-circuit contacts as this can permanently destroy the battery.

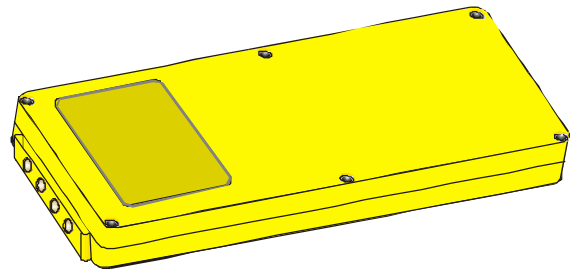

We recommend recharging the battery only when it is empty, i.e. when the red LED blinks or an acoustic signal sounds. Always store rechargeable batteries at room temperature.

3.1.2 FLG 102 Battery Charger

Recharging batteries

1. Connect battery charger to mains (refer to nameplate on battery charger for details).
2. Switch ON the battery charger via the rocker switch (pos. ①).
3. Insert battery with the nameplate facing up into the battery compartment (pos. ②).

Charging indicator (red LED ; pos. ③)

LED lit: battery charging.
 LED off or flashing: battery full, i.e. operable.
 LED flashes when
 inserting battery: battery totally discharged or defective.



Note :

- A discharged FuB 10 AA battery recharges in approx. 4 hours. The electronics in the battery charger ensure that charging does not exceed 5 hours.
- The quick charging of NiCd batteries should only take place at temperatures between 50 °F and 104 °F (+10 °C and +40 °C).
- Protect battery contacts against short circuits. Never store batteries in tool box or trouser pockets. A bunch of keys is enough to short the battery. Always use the protective cap included.
- Use the charger at room temperature and protect it from extreme heat (direct sun).



3.2 Special Operating Modes (Optional)

This chapter describes special operating modes that are not available with all crane systems. If your radio control system is not equipped with the features described, you may ignore the following and continue with the next chapter.

3.2.1 Scanner (Frequency Selection) Option

With the option scanner, the transmitter and the receiver are equipped with 4 radio frequencies each (refer to wiring diagrams).

If the radio channel used is currently occupied by another operator, another radio channel may be selected via a rotary switch. The scanner in the receiver will automatically follow the transmitter to the radio frequency selected.

After switching ON the transmitter (STOP button unlocked ; confer to chapter 3) or after a frequency change during operation, it will last only a short time until the receiver has "followed" the transmitter to the frequency selected.



3.2.2 Cable Control Option

With the cable control option the operator can also control his crane or machine without using radio control

He merely has to connect the receiver mounted on his crane or machine to the cable control connection (fig. below) on the transmitter via a cable (standard length 66 ft. [20 m] to max. 328 ft. [100 m]).

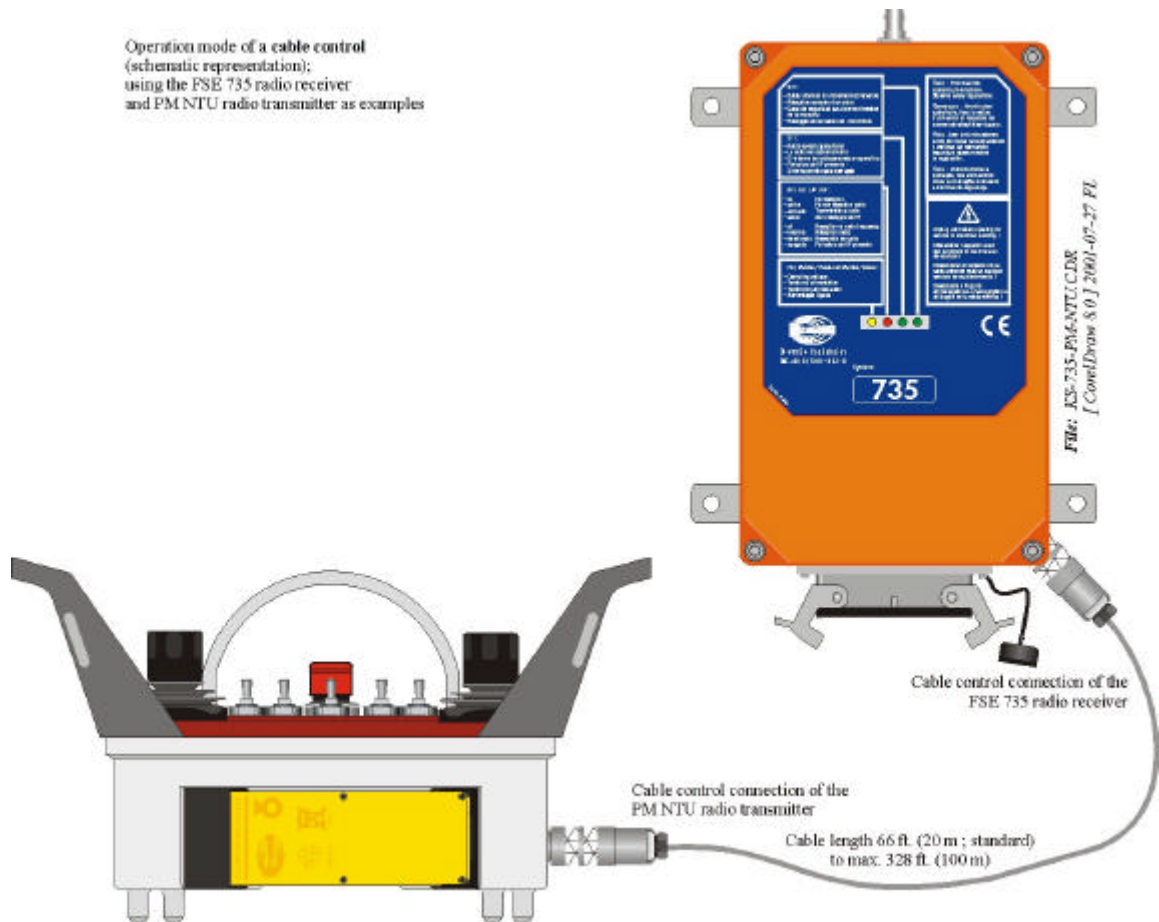

The cable connection between the transmitter and receiver can be made when the radio system is active. After the transmitter has been connected to the receiver via the cable, the transmitter **must** be restarted by pressing the “START” pushbutton.



Note :

If the transmitter is connected with the receiver via cable, the transmitter module in the transmitter automatically switches off.



4 Trouble-Shooting



Note :

Check the functions with the cabin or the cable control unit first !

Trouble	Possible Cause	Remedy
No reaction whenever the transmitter is switched ON.	<ul style="list-style-type: none"> - No operating voltage is present. 	<ul style="list-style-type: none"> - Check the battery contacts for damage or contamination. - Insert a fully charged battery in battery compartment. - Recharge battery.
Low-power indicator blinks after minimal operating time, i.e. red LED illuminates.	<ul style="list-style-type: none"> - The battery contacts are contaminated or damaged. - The battery is not charged. - The battery is defective. 	<ul style="list-style-type: none"> - Check battery contacts for damage or contamination. - Fully recharge battery. - Ensure that recharging process runs correctly. - Check transmitter functions using a fully charged or replacement battery.



5 Maintenance

The radio control system is largely maintenance-free. The following items should nevertheless be taken into account :

- Make sure that the STOP button moves easily.
Dirt of any kind may interfere with the operation of the switch or even render it impossible.
- Inspect the rubber bellows of the compact joysticks regularly for leak-tightness.
Replace immediately if cracks appear since the penetration of dirt and humidity may damage the function of the compact joysticks.
- The batteries of the transmitter should be completely discharged and charged again on a regular basis.
- Never "clean" the transmitter with a pressure or with a steam cleaner.
If necessary, clean it with a fine brush or soft cloth, please.



Note:

In the event of any problems with the radio control system, contact your local distributor or HBC-radiomatic, Inc. .

5.1 In The Event of a Fault



Warning:

Never operate a crane or machine with a faulty or defective radio control system.

- Never try to repair the radio receiver electronics! Opening the transmitter housing terminates the manufacturer guarantee.
 - Send any defective or faulty equipment to you local distributor or to the manufacturer. They are experts and have the necessary know-how and OEM spare parts.
 - Always send transmitter **and** receiver and enclose a detailed description of the problem.
 - Do not forget to enclose your address and telephone number so that we can get in touch with you quickly if necessary.
- To avoid damage during transport, use the original packing supplied with the transmitter and receiver, otherwise pack securely. Send the consignment to your distributor or to the following address :

HBC-radiomatic , Inc.
4480 Lake Forest Drive, Suite 306
Cincinnati, OH 45242, USA
Telephone : (513) – 7 33 – 49 00
Fax : (513) – 7 33 – 49 03
- Should you decide to personally return a defective radio control system to your distributor or HBC-radiomatic , Inc., then please make an appointment first.



6 Technical Data

General Technical Data	
<i>System</i>	PM NTU
<i>Max. number of control commands</i>	32 digital or 8 analog + 24 digital
<i>Unique system addresses</i>	over 65,000 combinations
Transmitter-specific Technical Data	
<i>Transmitting power</i>	<i>FuS 671/3 :</i> < 10 mW (synthesizer) <i>FuS 680/3 :</i> < 5 mW (synthesizer)
<i>Transmitter antenna</i>	internal
<i>Battery type</i>	FuB 10 AA (yellow , NiCd)
<i>Power supply with NiCd battery</i>	6 V DC / 1200 mAh
<i>Battery charge</i>	<i>at 50 % duty cycle :</i> 16 hours <i>at 100 % duty cycle :</i> 8 hours
<i>Operating temperature range</i>	-13 °F to +167 °F (-25 °C to +75 °C)
<i>Housing material</i>	glass-fiber reinforced plastic
<i>Housing color</i>	<i>lower part :</i> grey <i>upper part :</i> red
<i>Dimensions</i>	9.8 x 2.5 x 2.0 " (255 x 64 x 50 mm)
<i>Weight</i>	approx. 7.7 lb. (3,5 kg)
<i>System of protection</i>	Nema 4 (IP 55)



6.1 Dimensions of the PM NTU

