

TEST REPORT

Test Report No.: 1-2184-01-03/10-B



Testing Laboratory

CETECOM ICT Services GmbH
Untertürkheimer Straße 6 – 10
66117 Saarbrücken/Germany
Phone: + 49 681 5 98 - 0
Fax: + 49 681 5 98 - 9075
Internet: <http://www.cetecom.com>
e-mail: ict@cetecom.com

Accredited Test Laboratory:

The test laboratory (area of testing) is accredited according to DIN EN ISO/IEC 17025
DAR registration number: DGA-PL-176/94-D1

Area of Testing: Radio Satellite Communications

Applicant

HBC radiomatic GmbH
Haller Str. 45-53
74564 Crailsheim /Germany
Phone: +49 (0) 7951 393 0
Fax: +49 (0) 7951 393 723
Contact: D. Hahn
e-mail: dhahn@radiomatic.com
Phone: +49 (0) 7951 393 725

Manufacturer

HBC radiomatic GmbH
Haller Str. 45-53
74564 Crailsheim /Germany

Test Standard/s

47 CFR Part 15	Title 47 of the Code of Federal Regulations; Chapter I-Federal Communications Commission subchapter A - general, Part 15-Radio frequency devices
RSS - 210 Issue 7	Spectrum Management and Telecommunications - Radio Standards Specification Low-power Licence-exempt Radiocommunication Devices (All Frequency Bands): Category I Equipment

For further applied test standards please refer to section 3 of this test report.

Test Item

Kind of test item:	HBC remote control
Model name:	Micron 5
FCC ID:	NO9TC691
IC:	2977A-TC691
Frequency [MHz]:	13.56 MHz
Power supply:	3.6 V DC from BA223030 Ni-MH battery
Temperature range:	-20 °C to +50 °C (normal indoor equipment)



This test report is electronically signed and valid without handwriting signature. For verification of the electronic signatures, the public keys can be requested at the testing laboratory.

Test performed:

Meheza K. Walla

Test Report authorised:

Jakob Reschke

1 Table of contents

1 Table of contents2

2 General information3

 2.1 Notes.....3

 2.2 Application details.....3

3 Test standard/s3

4 Test environment.....3

5 Test item4

6 Test laboratories sub-contracted4

7 Summary of measurement results5

8 RF measurement testing.....6

 8.1 Description of test setup6

 8.1.1 Radiated measurements.....6

 8.1.2 Conducted measurements.....7

 8.2 Additional comments7

 8.3 RSP100 Test report cover sheet / Performance test data8

9 Measurement results.....9

 9.1 Timing of the transmitter9

 9.2 Field strength of the fundamental11

 9.3 Occupied bandwidth12

 9.4 Field strength of the harmonics and spurious13

10 Test equipment and ancillaries used for tests17

Annex A Photographs of the test set-up.....19

Annex B External photographs of the EUT.....20

Annex C Internal photographs of the EUT22

Annex D Document history28

Annex E Further information.....28

2 General information

2.1 Notes

The test results of this test report relate exclusively to the test item specified in this test report. CETECOM ICT Services GmbH does not assume responsibility for any conclusions and generalisations drawn from the test results with regard to other specimens or samples of the type of the equipment represented by the test item. The test report may only be reproduced or published in full. Reproduction or publication of extracts from the report requires the prior written approval of CETECOM ICT Services GmbH.

This test report is electronically signed and valid without handwriting signature. For verification of the electronic signatures, the public keys can be requested at the testing laboratory.

2.2 Application details

Date of receipt of order:	2010-05-31
Date of receipt of test item:	2010-08-02
Start of test:	2010-08-02
End of test:	2010-09-15
Person(s) present during the test:	-/-

3 Test standard/s

Test Standard	Version	Test Standard Description
47 CFR Part 15	2009-10	Title 47 of the Code of Federal Regulations; Chapter I-Federal Communications Commission subchapter A - general, Part 15-Radio frequency devices
RSS - 210 Issue 7	2007-06	Spectrum Management and Telecommunications - Radio Standards Specification Low-power Licence-exempt Radiocommunication Devices (All Frequency Bands): Category I Equipment

4 Test environment

Temperature:	T_{nom}	+23 °C during room temperature tests
	T_{max}	+50 °C during high temperature test
	T_{min}	-20 °C during low temperature test
Relative humidity content:		51 %
Air pressure:		not relevant for this kind of testing
Power supply:	V_{nom}	3.6 V DC from BA223030 Ni-MH battery

5 Test item

Kind of test item	:	HBC remote control
Type identification	:	Micron 5
S/N serial number	:	516-1016513
HW hardware status	:	Not specified
SW software status	:	SC008202
Frequency Band [MHz]	:	13.56 MHz
Type of Modulation	:	N0N
Number of channels	:	1
Antenna	:	Integrated antenna → for more information, please take a look at the Annex B – external photos of the EUT.
Power Supply	:	3.6 V DC from BA223030 Ni-MH battery
Temperature Range	:	-20 °C to +50 °C

6 Test laboratories sub-contracted

None

7 Summary of measurement results

- No deviations from the technical specifications were ascertained**
- There were deviations from the technical specifications ascertained

TC Identifier	Description	Verdict	Date	Remark
RF-Testing	CFR Part 15 RSS 210, Issue 7, Annex 2.6	Passed	2010-09-15	-/-

Test Specification Clause	Test Case	Temperature Conditions	Power Source Voltages	Pass	Fail	NA	NP	Results (max.)
§ 15.35 (c)/ RSS-GEN Issue 2 Section 4.5	Timing of the transmitter (Duty cycle correction factor)	Nominal	Nominal	<input checked="" type="checkbox"/>	<input type="checkbox"/>	<input type="checkbox"/>	<input type="checkbox"/>	complies
§ 15.209 (a)/ RSS-210 Issue 7 Annex 2.6	Fieldstrength of Fundamental	Nominal	Nominal	<input checked="" type="checkbox"/>	<input type="checkbox"/>	<input type="checkbox"/>	<input type="checkbox"/>	complies
§ 15.209/ RSS-210 Issue 7 Annex 2.6	Fieldstrength of harmonics and spurious	Nominal	Nominal	<input checked="" type="checkbox"/>	<input type="checkbox"/>	<input type="checkbox"/>	<input type="checkbox"/>	complies

Note:NA = Not Applicable; NP = Not Performed

8 RF measurement testing

8.1 Description of test setup

8.1.1 Radiated measurements

The radiated measurements are performed in vertical and horizontal plane in the frequency range from 9 kHz to 25 GHz in semi-anechoic chambers. The EUT is positioned on a non-conductive support with a height of 0.80 m above a conductive ground plane that covers the whole chamber. The receiving antennas are confirmed with specifications ANSI C63.2-1996 clause 15 and ANSI C63.4-2003 clause 4.1.5. These antennas can be moved over the height range between 1.0 m and 4.0 m in order to search for maximum field strength emitted from EUT. The measurement distances between EUT and receiving antennas are indicated in the test setups for the various frequency ranges. For each measurement, the EUT is rotated in all three axes until the maximum field strength is received. The wanted and unwanted emissions are received by spectrum analysers where the detector modes and resolution bandwidths over various frequency ranges are set according to requirement ANSI C63-4-2003 clause 4.2.

Antennas are confirmed with ANSI C63.2-1996 item 15.

Picture 1: Diagram radiated measurements

Semi anechoic chamber

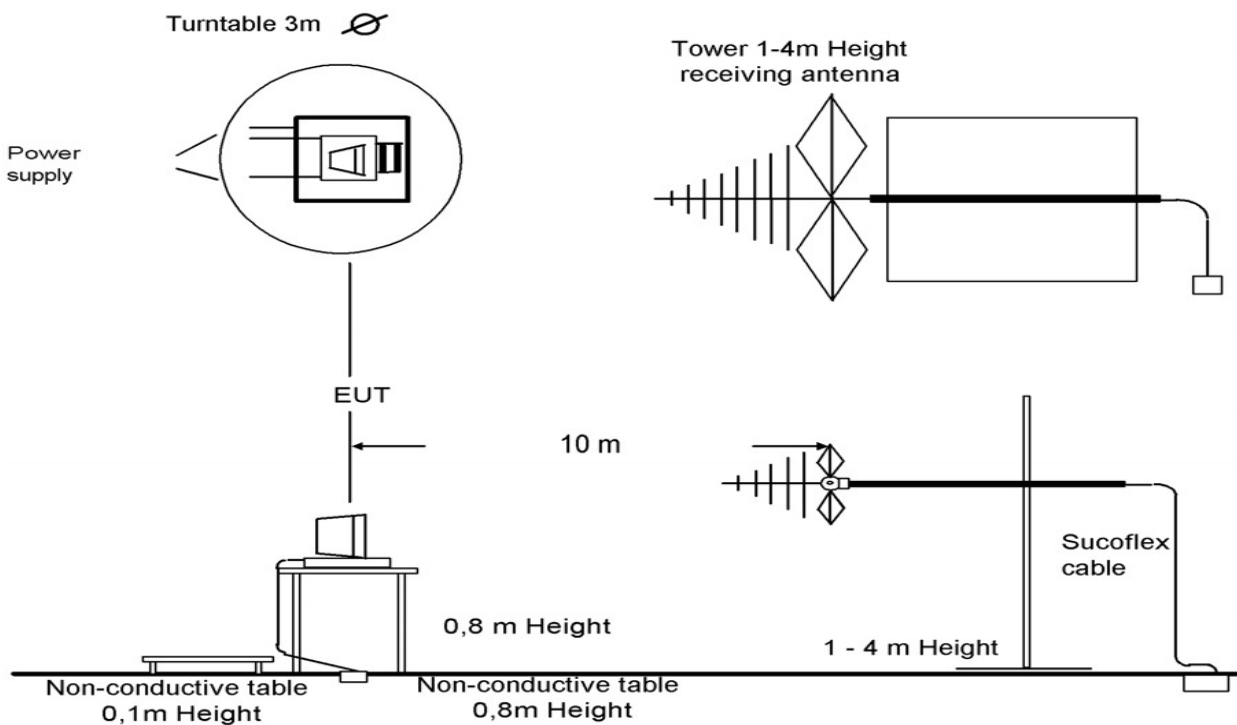

9 kHz - 30 MHz:	active loop antenna
30 MHz – 1 GHz:	tri-log antenna
> 1 GHz:	horn antenna

8.1.2 Conducted measurements

The EUT's RF signal is coupled out by the antenna connector which is supplied by the manufacturer. The signal is first 10dB attenuated before it is power divided (~6dB loss per branch). One of the signal paths is connected to the communication base Station (CMU200 or other), the other one is connected to the spectrum analyzer. The specific losses for both signal paths are first checked within a calibration. The measurement readings on the signalling unit/spectrum analyzer are corrected by the specific test set-up loss. The attenuator, power divider, signalling unit and the spectrum analyzer are impedance matched on 50 Ohm.

Picture 2: Diagram conducted measurements

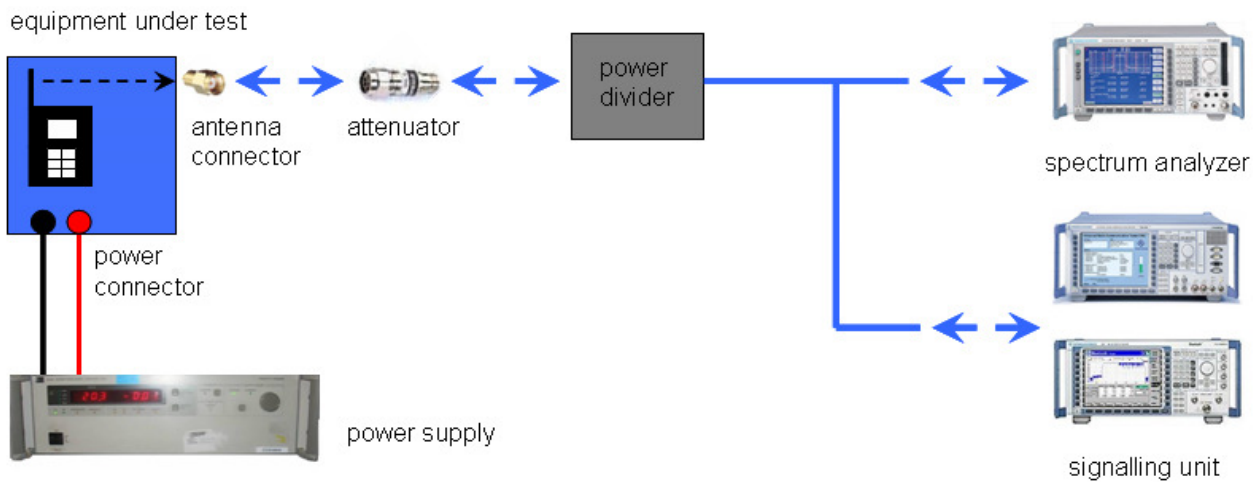

8.2 Additional comments

Reference documents: None

Special test descriptions: None

Configuration descriptions: None

8.3 RSP100 Test report cover sheet / Performance test data

Test Report Number	:	1-2184-01-03/10-B
Equipment Model Number	:	micron 5
Certification Number	:	2977A-TC691
Manufacturer (complete Address)	:	HBC radiomatic GmbH Haller Str. 45-53 74564 Crailsheim /Germany
Tested to radio standards specification no.	:	RSS 210, Issue 7, Annex 8
Open Area Test Site IC No.	:	IC 3462C-1
Frequency Range or fixed frequency	:	13.56 MHz
Field Strength [dB μ V/m] (at 3 m)	:	50 dB μ V/m at 3 m
Occupied bandwidth (99%-BW) [kHz]	:	13.63 kHz (RBW 3 kHz)
Type of modulation	:	N0N
Emission Designator (TRC-43)	:	13k6N0N
Antenna Information	:	Integrated antenna → for more information, please take a look at the Annex B – external photos of the EUT.
Transmitter Spurious (worst case)	:	22.8 dB μ V/m at 10 m
Receiver Spurious (worst case)	:	22.4 dB μ V/m at 10 m

ATTESTATION:

DECLARATION OF COMPLIANCE:

I attest that the testing was performed or supervised by me; that the test measurements were made in accordance with the above-mentioned Industry Canada standard(s); and that the equipment identified in this application has been subjected to all the applicable test conditions specified in the Industry Canada standards and all of the requirements of the standard have been met.

Laboratory Manager:

2010-09-15
Date

Meheza K. Walla
Name

Signature

9 Measurement results

9.1 Timing of the transmitter

Plot 1:

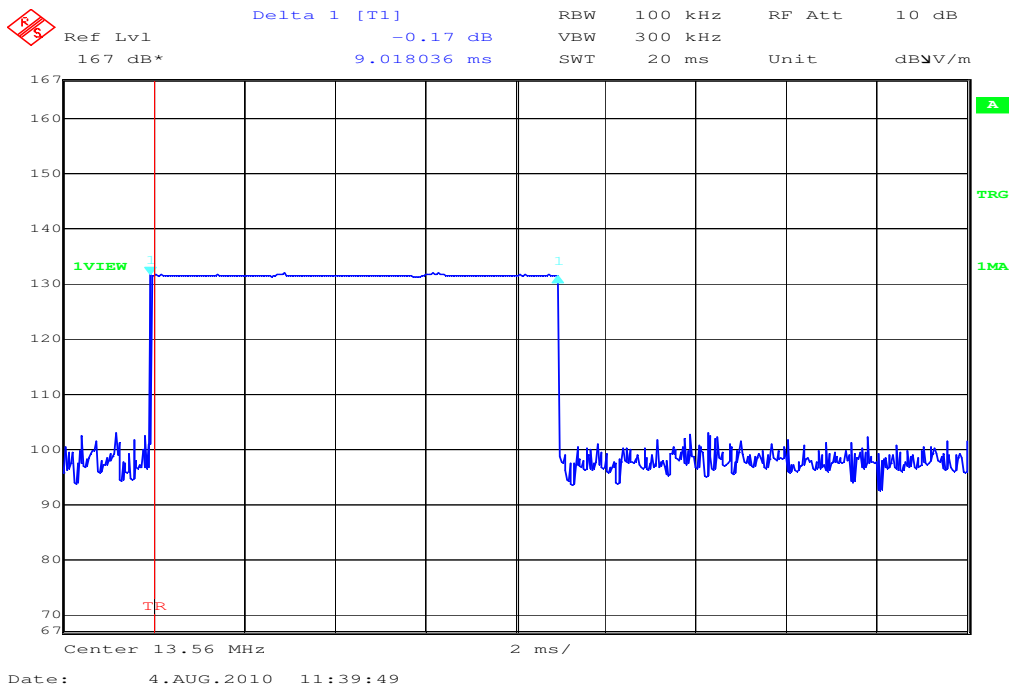

Plot 2:

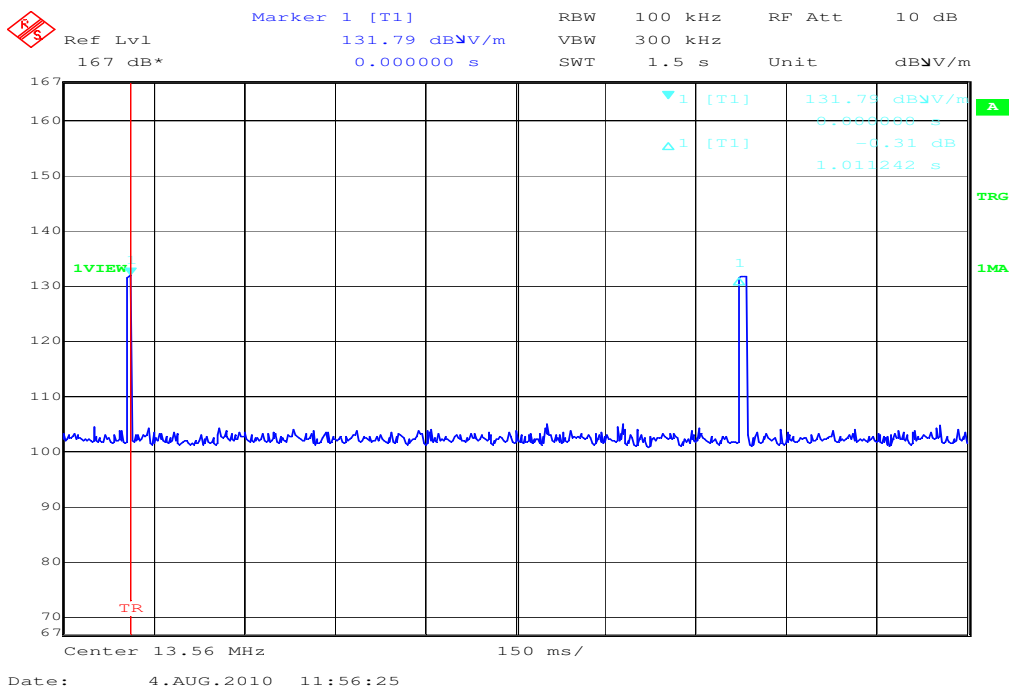

Limits:

FCC	IC
CFR Part SUBCLAUSE § 15.35 (c)	RSS-GEN Issue 2 Section 4.5
Timing of the transmitter	
<p>(c) Unless otherwise specified, e.g. Section 15.255(b), when the radiated emission limits are expressed in terms of the average value of the emission, and pulsed operation is employed, the measurement field strength shall be determined by averaging over one complete pulse train, including blanking intervals, as long as the pulse train does not exceed 0.1 seconds. As an alternative (provided the transmitter operates for longer than 0.1 seconds) or in cases where the pulse train exceeds 0.1 seconds, the measured field strength shall be determined from the average absolute voltage during a 0.1 second interval during which the field strength is at its maximum value. The exact method of calculating the average field strength shall be submitted with any application for certification or shall be retained in the measurement data file for equipment subject to notification or verification.</p>	

Result: The result of the measurement is passed.

9.2 Field strength of the fundamental

Result:

TEST CONDITIONS		MAXIMUM POWER (dB μ V/m)	
Frequency		13.56 MHz	13.56 MHz
Mode		at 3 m distance (measured)	at 30 m distance (calculated)
$T_{nom} = +23\text{ }^{\circ}\text{C}$	$V_{nom} = 3.6$	50	10
Measurement uncertainty		$\pm 3\text{dB}$	

(To convert the measuring distance from 3m to 10m and 30m a correction factor from 40 dB/decade was used. Here we used 40 dB to recalculate from 3m to 30m).

FCC		IC	
SUBCLAUSE § 15.209			
Field strength of the harmonics and spurious.			
Frequency (MHz)	Field strength ($\mu\text{V/m}$)	Measurement distance (m)	
0.0009 – 0.490	2400/F(kHz)	300	
0.490 – 1.705	24000/F(kHz)	30	
1.705 – 30	30 (29.5 dB $\mu\text{V/m}$)	30	
30 – 88	100 (40 dB $\mu\text{V/m}$)	3	
88 – 216	150 (43.5 dB $\mu\text{V/m}$)	3	
216 – 960	200 (46 dB $\mu\text{V/m}$)	3	

RBW/VBW: 200 Hz up to 150 kHz, 9 kHz up to 30 MHz, 120 kHz up to 1 GHz

Result: The result of the measurement is passed.

9.3 Occupied bandwidth

For information only

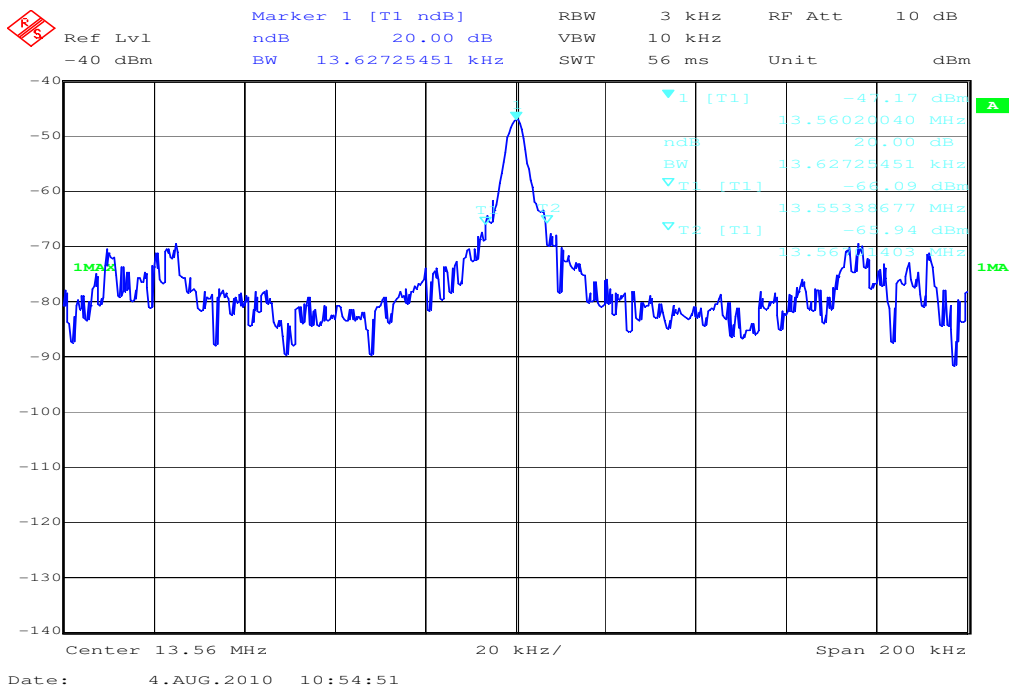

9.4 Field strength of the harmonics and spurious

Measurement:

Measurement parameter	
Detector:	Average / Quasi Peak
Sweep time:	Auto
Resolution bandwidth:	120 kHz
Video bandwidth:	100 kHz
Span:	Steps of 3 MHz < 30 MHz Steps of 100 MHz > 30 MHz
Trace-Mode:	Max hold

Limits:

FCC	IC	
SUBCLAUSE § 15.209		
Field strength of the harmonics and spurious.		
Frequency (MHz)	Field strength ($\mu\text{V/m}$)	Measurement distance (m)
0.0009 – 0.490	2400/F(kHz)	300
0.490 – 1.705	24000/F(kHz)	30
1.705 – 30	30 (29.5 dB $\mu\text{V/m}$)	30
30 – 88	100 (40 dB $\mu\text{V/m}$)	3
88 – 216	150 (43.5 dB $\mu\text{V/m}$)	3
216 – 960	200 (46 dB $\mu\text{V/m}$)	3

Result: The result of the measurement is passed.

Plots of the measurements

Plot 1: TX-Mode, 9 kHz – 30 MHz @ 3 m

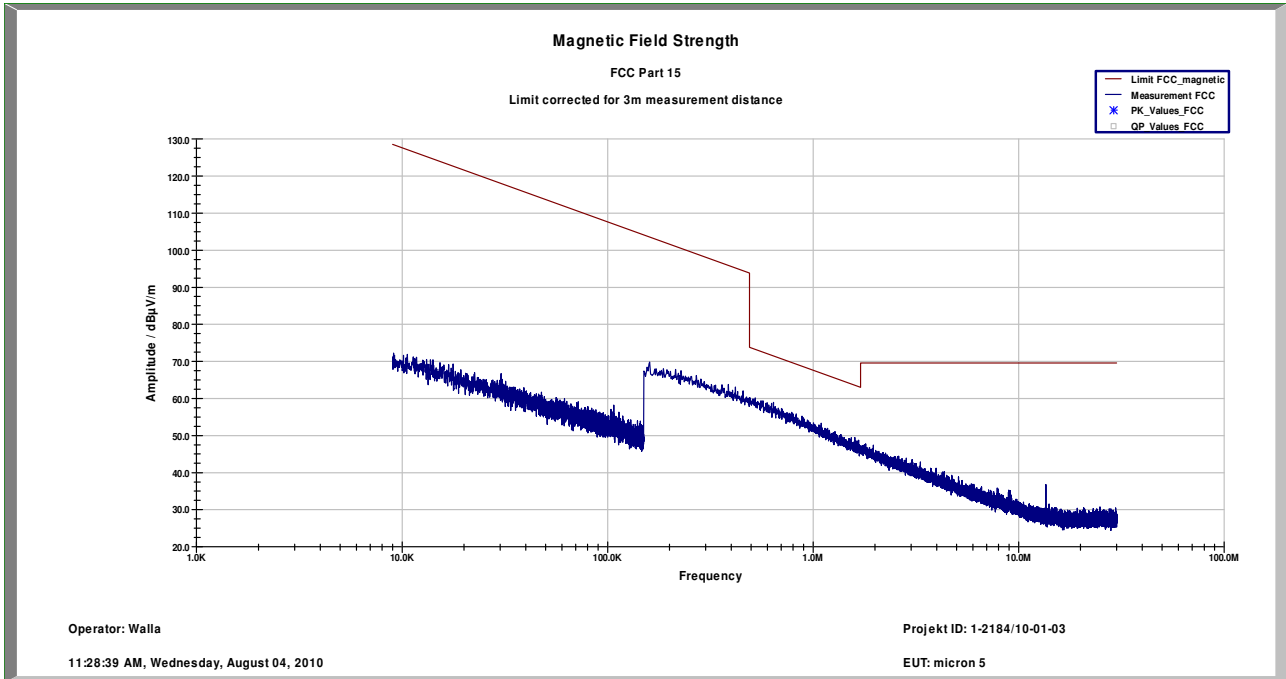

Plot 2: RX-Mode, 9 kHz – 30 MHz @ 3 m

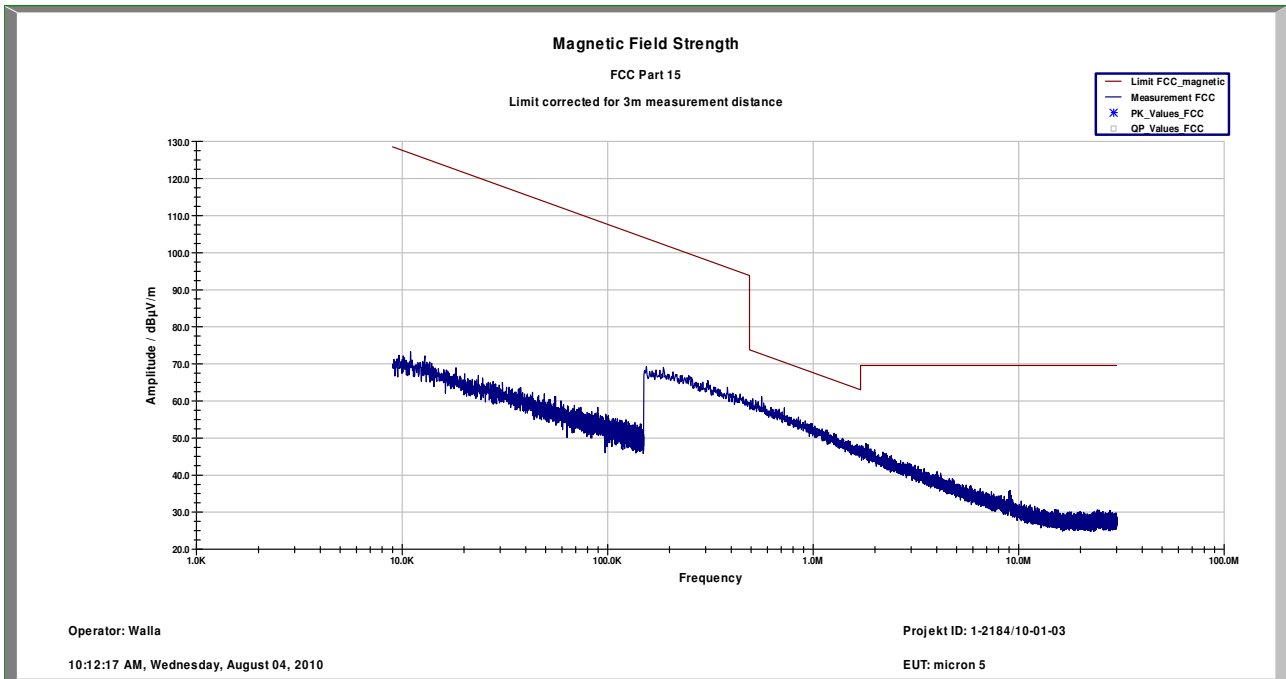

Plot 3: TX-Mode, 30 MHz to 1 GHz @ 10 m

Information

EUT:	micron 5
Serial Number:	516-1016513 (modul: TC690)
Test Description:	FCC part 15 C Class B @ 10m
Operating Conditions:	TX-Mode, 13.56 MHz
Operator Name:	Kraus
Comment:	battery powered 3.6 V DC

Scan Setup: STAN_Fin [EMI radiated]

Hardware Setup:	Electric Field (NOS)
Level Unit:	dBµV/m

Subrange	Detectors	IF Bandwidth	Meas. Time	Receiver
30 MHz - 1,05 GHz	QuasiPeak	120 kHz	15 s	Receiver

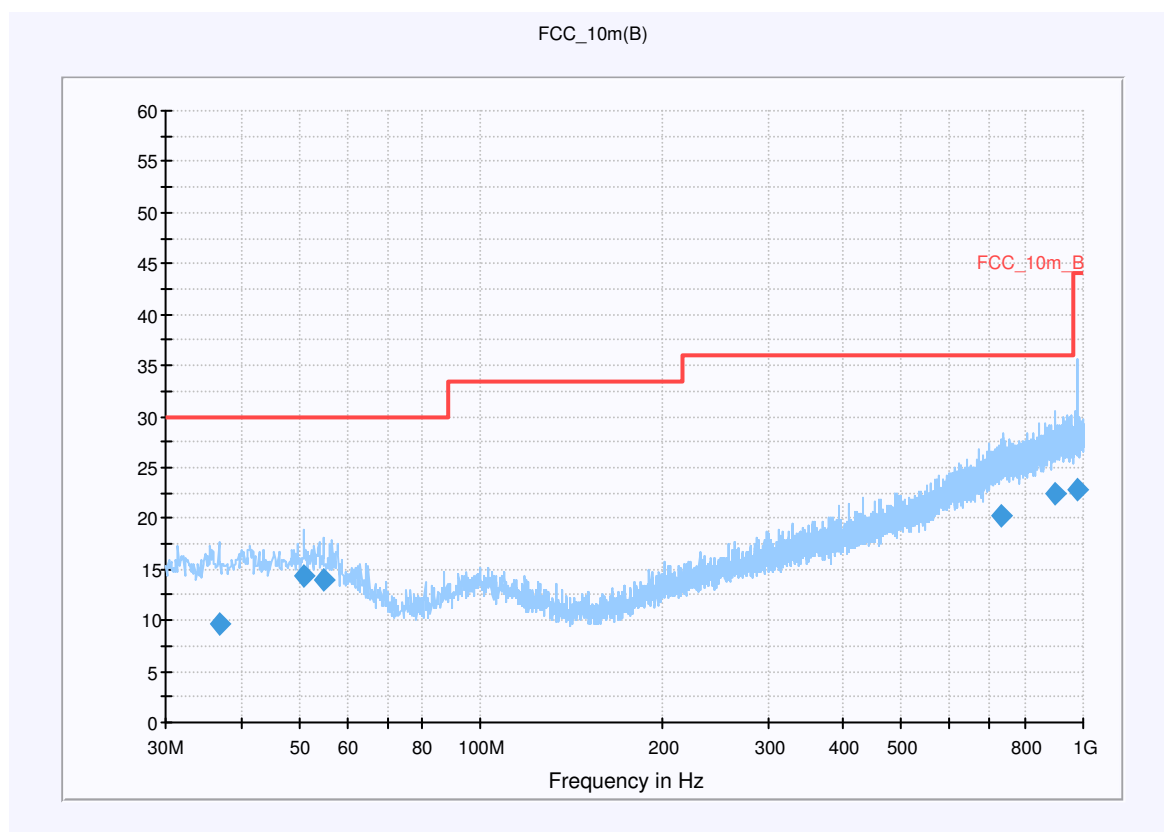

Frequency (MHz)	QuasiPeak (dBµV/m)	Meas. Time (ms)	Bandwidth (kHz)	Antenna height (cm)	Polarity	Turntable position (deg)	Corr. (dB)	Margin (dB)	Limit (dBµV/m)
36.868050	9.6	15000.000	120.000	361.0	H	138.0	13.2	20.4	30.0
50.989350	14.4	15000.000	120.000	127.0	V	190.0	13.3	15.6	30.0
54.973050	13.9	15000.000	120.000	274.0	V	335.0	12.9	16.1	30.0
730.129200	20.3	15000.000	120.000	198.0	H	236.0	23.2	15.7	36.0
898.356750	22.4	15000.000	120.000	207.0	H	119.0	25.2	13.6	36.0
976.819350	22.8	15000.000	120.000	400.0	H	162.0	25.6	21.2	44.0

Plot 4: RX-Mode, 30 MHz to 1 GHz @ 10 m

Information

EUT:	micron 5
Serial Number:	516-1016513 (modul: TC690)
Test Description:	FCC part 15 B Class B @ 10m
Operating Conditions:	RX-Mode
Operator Name:	Kraus
Comment:	battery powered 3.6 V DC

Scan Setup: STAN_Fin [EMI radiated]

Hardware Setup:	Electric Field (NOS)
Level Unit:	dBµV/m

Subrange	Detectors	IF Bandwidth	Meas. Time	Receiver
30 MHz - 1,05 GHz	QuasiPeak	120 kHz	15 s	Receiver

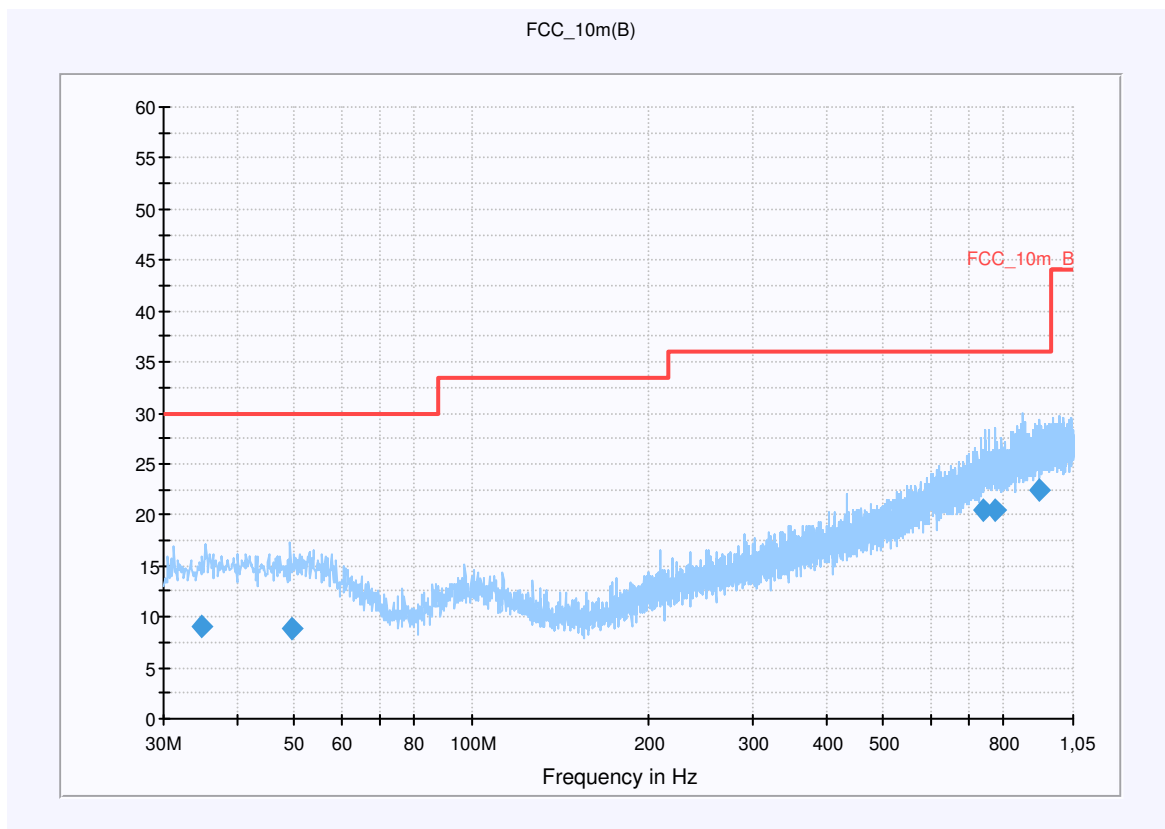

Frequency (MHz)	QuasiPeak (dBµV/m)	Meas. Time (ms)	Bandwidth (kHz)	Antenna height (cm)	Polarity	Turntable position (deg)	Corr. (dB)	Margin (dB)	Limit (dBµV/m)
34.813350	9.1	15000.000	120.000	128.0	V	13.0	13.0	20.9	30.0
49.463700	8.8	15000.000	120.000	209.0	H	13.0	13.4	21.2	30.0
740.842200	20.4	15000.000	120.000	220.0	V	5.0	23.4	15.6	36.0
774.126600	20.5	15000.000	120.000	120.0	V	201.0	23.7	15.5	36.0
920.228550	22.4	15000.000	120.000	220.0	V	271.0	25.3	13.6	36.0

10 Test equipment and ancillaries used for tests

Typically, the calibrations of the test apparatus are commissioned to and performed by an accredited calibration laboratory. The calibration intervals are determined in accordance with the DIN EN ISO/IEC 17025. In addition to the external calibrations, the laboratory executes comparison measurements with other calibrated test systems or effective verifications. Weekly chamber inspections and range calibrations are performed. Where possible, rf-generating and signalling equipment as well as measuring receivers and analyzers are connected to an external high-precision 10 MHz reference (GPS-based or rubidium frequency standard).

In order to simplify the identification of the equipment used at some special tests, some items of test equipment and ancillaries can be provided with an identifier or number in the equipment list below (Labor/Item).

No.	Labor / Item	Equipment	Type	Manufact.	Serial No.	INV. No Cetecom	Kind of Calibration	Last Calibration	Next Calibration
1	45	Switch-Unit	3488A	HP Meßtechnik	2719A14505	300000368	g		
2	50	DC power supply, 60Vdc, 50A, 1200 W	6032A	HP Meßtechnik	2920A04466	300000580	k	06.01.2009	06.01.2011
3	n. a.	software	SPS_PHE 1.4f	Spitzberger & Spieß	B5981; 5D1081;B5979	300000210	ne		
4	n. a.	EMI Test Receiver	ESCI 1166.5950.03	R&S	100083	300003312	k	08.01.2010	08.01.2012
5	n. a.	Analyzer-Reference-System (Harmonics and Flicker)	ARS 16/1	SPS	A3509 07/0 0205	300003314	k	01.06.2009	01.06.2011
6	n. a.	Amplifier	JS42-00502650-28-5A	MITEQ	1084532	300003379	ev		
7	n. a.	Antenna Tower	Model 2175	ETS-LINDGREN	64762	300003745	izw		
8	n. a.	Positioning Controller	Model 2090	ETS-LINDGREN	64672	300003746	izw		
9	n. a.	Turntable Interface-Box	Model 105637	ETS-LINDGREN	44583	300003747	izw		
10	n. a.	TRILOG Broadband Test-Antenna 30 MHz - 3 GHz	VULB9163	Schwarzbeck	295	300003787	k	01.04.2010	01.04.2012
11	n. a.	Spectrum-Analyzer	FSU26	R&S	200809	300003874	k	08.01.2010	08.01.2012
12	n. a.	DC power supply, 60Vdc, 50A, 1200 W	6032A	HP Meßtechnik	2818A03450	300001040	Ve	08.01.2009	08.01.2012
13	n. a.	PowerAttenuator	8325	Byrd	1530	300001595			
14	n. a.	Double-Ridged Waveguide Horn Antenna 1-18.0GHz	3115	EMCO	8812-3088	300001032	vIKI!	05.03.2009	05.03.2011
15	n. a.	Active Loop Antenna	6502	EMCO	2210	300001015	ne		
16	n. a.	Loop Antenna 9 kHz – 30 MHz	HFH2-Z2	R&S	872096/61	300001824	vIKI!	18.11.2008	18.11.2011
17	n. a.	Anechoic chamber		MWB	87400/02	300000996			
18	Spec.A. 2_2e	System rack for EMI measurement solution	85900	HP I.V.	*	300000222	ne		
19	9	Artificial Mains 9 kHz to 30 MHz, 4 x 25 Ampere	ESH3-Z5	R&S	828576/020	300001210	Ve	06.01.2010	06.01.2012
20	n. a.	Relais Matrix	3488A	HP Meßtechnik	2719A15013	300001156	ne		
21	n. a.	Relais Matrix	PSU	R&S	890167/024	300001168	ne		
22	n. a.	Isolating Transformer	RT5A	Grundig	9242	300001263	ne		
23	n. a.	Three-Way Power Splitter, 50 Ohm	11850C	HP Meßtechnik		300000997	ne		
24	n. a.	Switch / Control Unit	3488A	HP	2605e08770	300001443	ne		
25	n. a.	Band Reject filter	WRCG1855/1910-1835/1925-40/8SS	Wainwright	7	300003350	ev		

26	n. a.	Band Reject filter	WRCG2400/2483-2375/2505-50/10SS	Wainwright	11	300003351	ev		
27	n. a.	TILE-Software Emission	Quantum Change, Modell TILE-ICS/FULL	EMCO	none	300003451	ne		
28	n. a.	Highpass Filter	WHKX2.9/18G-12SS	Wainwright	1	300003492	ev		
29	n. a.	Highpass Filter	WHK1.1/15G-10SS	Wainwright	3	300003255	ev		
30	n. a.	Highpass Filter	WHKX7.0/18G-8SS	Wainwright	18	300003789	ne		
31	n. a.	PSA Spectrum Analyzer 3 Hz - 26.5 GHz	E4440A	Agilent Technologies	MY48250080	300003812	k	05.08.2008	*)
32	n. a.	MXG Microwave Analog Signal Generator	N5183A	Agilent Technologies	MY47420220	300003813	k	06.08.2008	*)
33	n. a.	RF Filter Section 9kHz - 1GHz	N9039A	Agilent Technologies	MY48260003	300003825	vlk!	19.08.2008	*)
34	n. a.	TRILOG Broadband Test-Antenna 30 MHz - 3 GHz	VULB9163	Schwarzbeck	371	300003854	vlk!	17.12.2008	17.12.2010
35	n. a.	Spectrum Analyzer 20 Hz - 50 GHz	FSU50	R&S	200012	300003443	ve	01.07.2010	01.07.2012

Agenda: Kind of Calibration

k	calibration / calibrated
ne	not required (k, ev, izw, zw not required)
ev	periodic self verification
Ve	long-term stability recognized
vlk!	Attention: extended calibration interval
NK!	Attention: not calibrated

EK	limited calibration
zw	cyclical maintenance (external cyclical maintenance)
izw	internal cyclical maintenance
g	blocked for accredited testing
*)	next calibration ordered / currently in progress

Annex A Photographs of the test set-up

Photo documentation:

Photo 1:

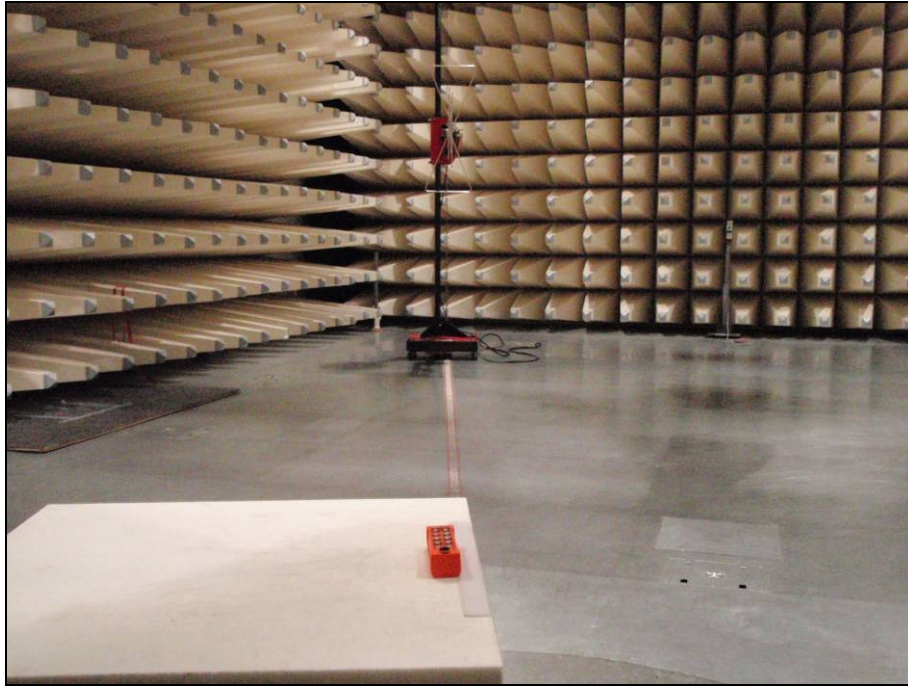
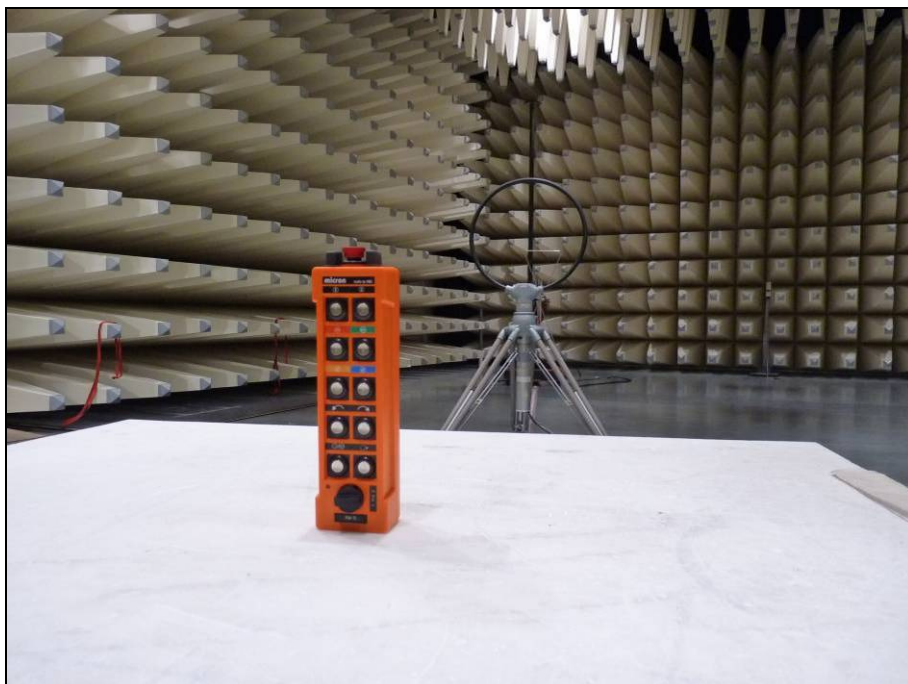

Photo 2:



Annex B External photographs of the EUT

Photo documentation:

Photo 1:



Photo 2:



Photo 3:



Photo 4:



Annex C Internal photographs of the EUT

Photo documentation:

Photo 1:

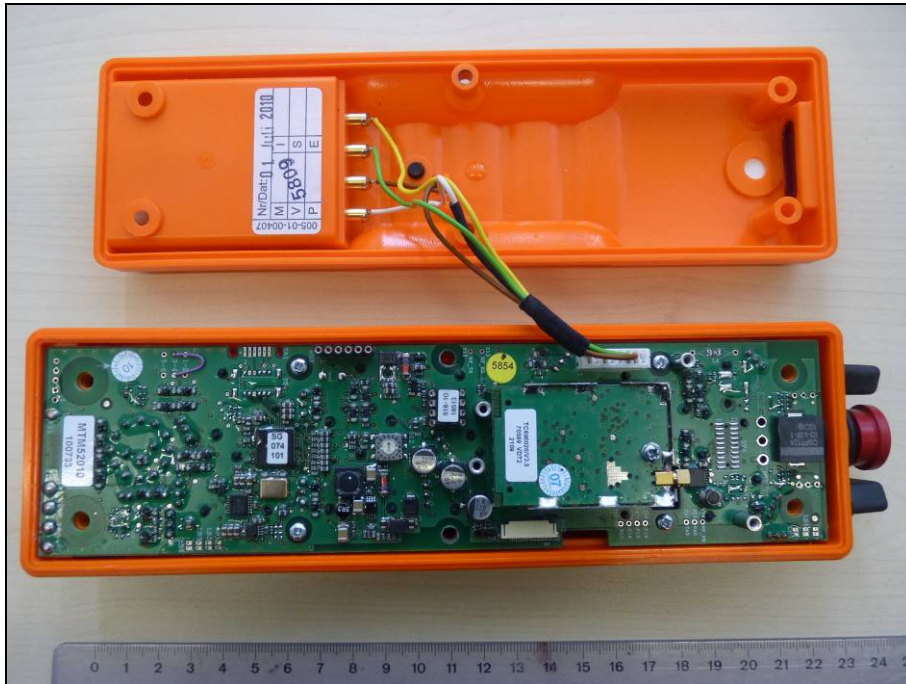

Photo 2:



Photo 3:



Photo 4:

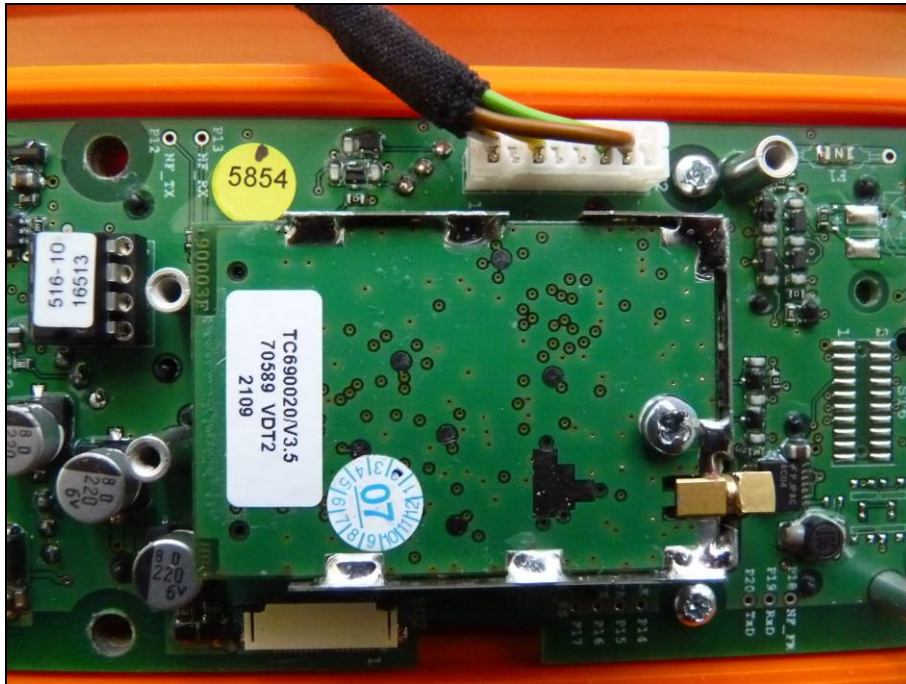

Photo 5:

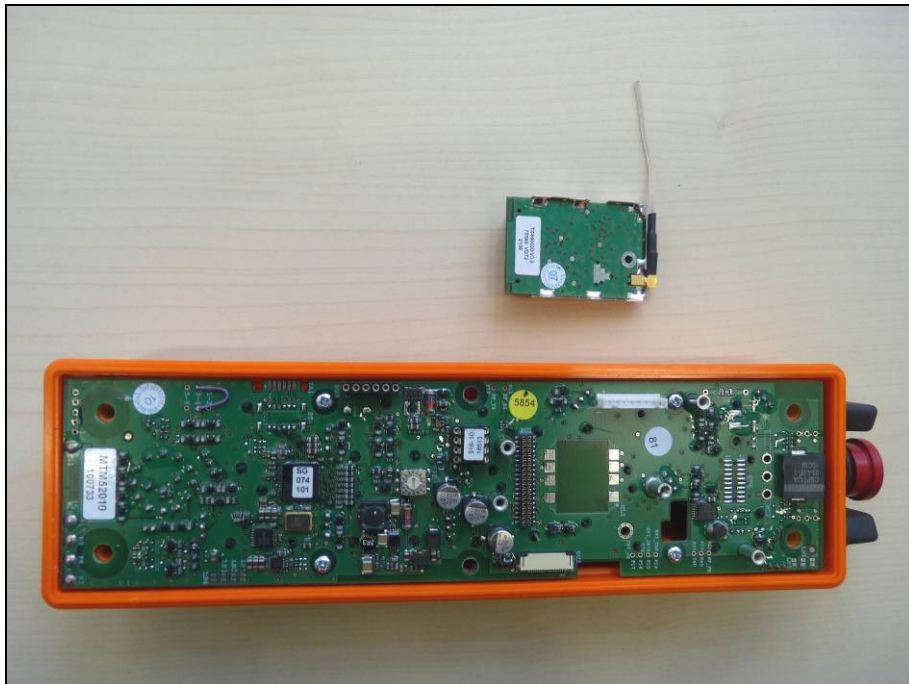

Photo 6:

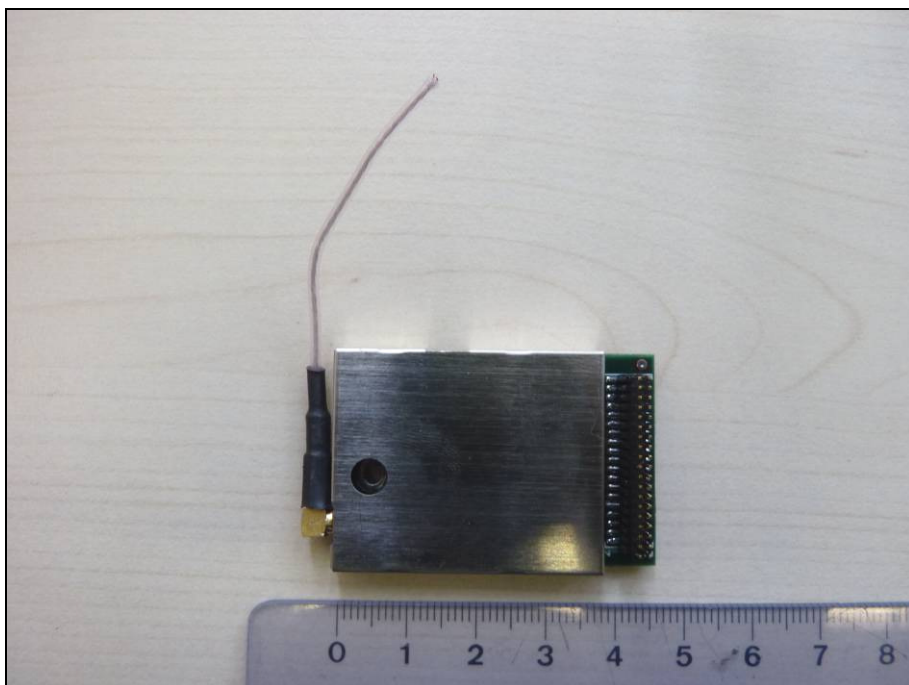

Photo 7:

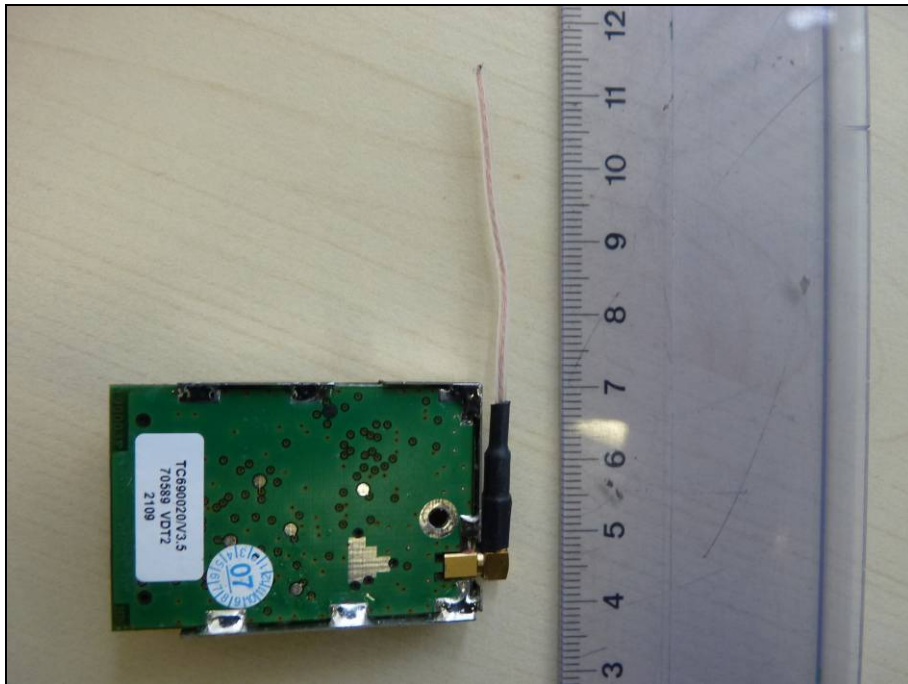

Photo 8:



Photo 9:

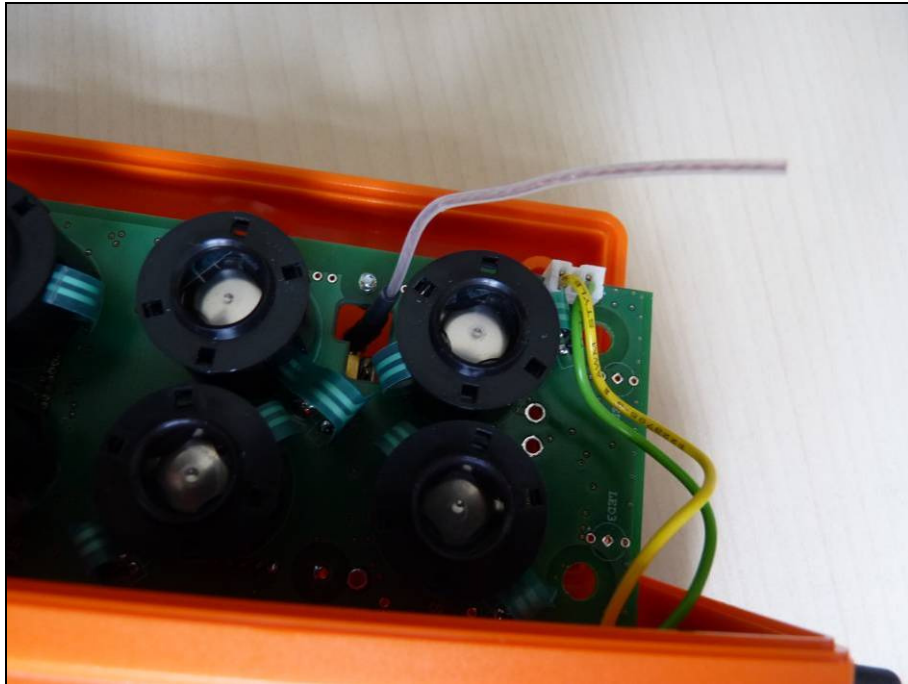
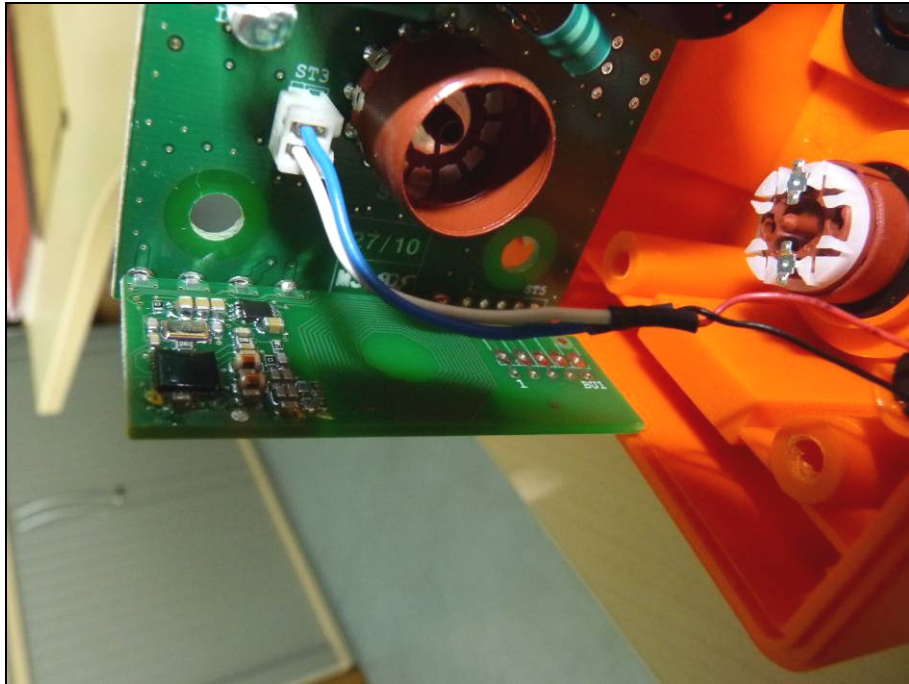

Photo 10:



Photo 11:



Annex D Document history

Version	Applied changes	Date of release
1.0	Initial release	2010-09-09
-A	Typos corrected	2010-09-14
-B	Photographs updated	2010-09-15

Annex E Further information

Glossary

DUT	-	Device under Test
EMC	-	Electromagnetic Compatibility
EUT	-	Equipment under Test
FCC	-	Federal Communication Commission
FCC ID	-	Company Identifier at FCC
HW	-	Hardware
IC	-	Industry Canada
Inv. No.	-	Inventory number
N/A	-	not applicable
S/N	-	Serial Number
SW	-	Software