

HBC – Radio Control

CE Radio Transmitter spectrum 1 M

for the Constructional and Industrial Use

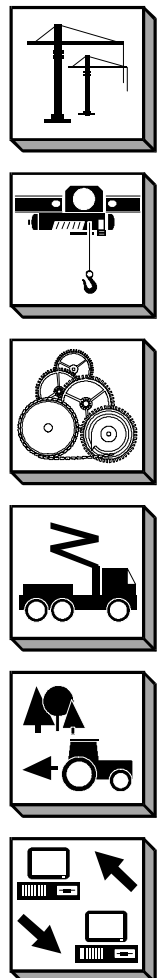



Manufacturer : HBC-radiomatic GmbH
Haller Straße 49 - 53
74564 Crailsheim • Germany
Tel. +49 (0) 79 51 – 3 93 - 0
Fax +49 (0) 79 51 – 3 93 - 50
E-mail: info@radiomatic.com
<http://www.hbc-radiomatic.com>

HBC radiomatic GmbH is not liable for any misprints or errors! – All rights reserved.

™ *radiomatic* is a registered German trademark.

© 2002 – 02 , HBC-radiomatic GmbH , D-74564 Crailsheim

No part of any software or of the present document may be reproduced in any manner whatsoever without the expressed written permission of HBC-radiomatic GmbH.

Table of Contents

1	Description	4
2	Safety Instructions	5
2.1	Pictographs.....	5
2.2	General Safety Instructions.....	6
2.3	Operator Safety Instructions	7
3	Operation.....	8
	Automatic Switch-OFF (APO Function)	9
	Slewing Gear Release.....	9
3.1	Battery and Battery Charger.....	10
3.1.1	FuB 05 AA Transmitter Battery.....	10
3.1.2	FLG 105 Battery Charger	10
3.2	Special Operating Modes (Optional).....	11
3.2.1	Option Scanner (Frequency Selector)	11
3.2.2	Option "Pitch – Catch".....	12
3.2.3	Option Tandem Operation.....	13
3.2.4	Option infrakey	16
3.2.4.1	infrakey Set-up.....	17
4	Fault Correction	18
5	Maintenance	19
5.1	In the Event of a Fault.....	19
6	Technical Data.....	20
6.1	Dimensions and Operating Elements of spectrum 1 M	21
6.1.1	Industrial Version	21
6.1.2	Constructional Version.....	22
7	Certification and Approvals	23

1 Description

The spectrum 1 M transmitter is designed to transmit command instructions for controlling construction, industrial and mobile cranes, hoists and machines.

Depending on the type and version selected, up to 24 control commands plus the integrated STOP commands are available to the operator.

A non-interchangeable system address ensures the functional safety of the radio control system when operating cranes or machines. This feature is particularly important when several cranes or machines are in use, for example in halls and shops. The system address is exclusively allocated to each HBC radio transmitter and its respective receiver.

It is not possible to activate crane or machine functions using a radio control system allocated to another crane or machine.

The radio control system consists of the spectrum 1 M transmitter, two rechargeable NiCd batteries, a battery charger and a receiver with antenna. The transmitter housing with integrated antenna is made of impact resistant plastic.

The transmitter is powered by rechargeable batteries. Two batteries and a memory effect-free battery charger are included.

State of the art radio technology complying with the latest guidelines of the regulations on labor safety and the use of highly developed microprocessor technology guarantees optimal operating safety, availability and longevity.

The transmitter has general telecommunications approvals. It is not necessary to have or to apply for a license to operate the transmitter with the respective receiver. The transmitter must be operated in the 433.100 MHz to 434.750 MHz range or 869 MHz to 870 MHz bandwidth. The transmitter is equipped with < 10 mW (average) transmitting power.

Operating the radio transmitter using a different frequency range or transmitting power requires the approval of the competent regulative authorities for telecommunication.

The following radio receivers may be used in conjunction with the spectrum 1 M radio transmitter :

FSE 716

FSE 722 B

FSE 735

Note :



Changes or modifications not expressly approved by the party responsible for compliance could void the user's authority to operate the equipment.

2 Safety Instructions

2.1 Pictographs

The following pictographs will be used throughout the present operating instructions :



Indicates a possible shock hazard

Contacting components under voltage may lead to death. Housing (e.g. hoods and lids) marked with this symbol may only be opened by qualified electricians after having disconnected the device from the mains supply (supply voltage, operating voltage or input terminal voltage).



Indicates safety relevant passages

You will find this pictograph as an indicator for occupational safety measures. The neglecting of such measures poses a serious hazard. Always observe the instructions and be particularly attentive and careful. Avoid any situations that could at any time be a danger to persons or machines.



Indicates important information

This symbol brings your attention to important information on how to secure a long serviceable life of the radio control system. Pay attention to the comments and instructions given. Ignoring the information provided may permanently impair the reliability and operability of the equipment.

2.2 General Safety Instructions

Radio controls facilitate and increase the operating efficiency of cranes and machines. Nevertheless, the operator must thoroughly understand and be in a position to properly use a radio control system !

- Read the Operating Instructions Manual carefully and thoroughly before working with the transmitter for the first time !
- The operator undertakes to strictly adhere to the instructions and proceedings described in this manual, as well as to follow the general rules and regulations for worker safety and accident prevention. Ignoring any such instructions or regulations could pose a fatal threat to the operator or others.
- Keep this manual on location and readily available at all times !
- Only authorized and properly trained personnel may operate the transmitter.
- Anyone who is under the influence of drugs, alcohol or medication that has a detrimental effect on a person's reactions may at no time commission, operate, maintain or repair the transmitter.
- Before switching the transmitter on ensure that no-one is or can be endangered by the initiated operation.
- With the first signs of any malfunction related to the operative safety and reliability of the device the operator must immediately shut down or not activate the transmitter. For the purpose of the present manual "shut down" implies :
 - switching OFF the transmitter,
 - storing the transmitter in a safe place and ensuring no unauthorized access,
 - de-energizing the receiver,
 - unplugging the connection cable on the receiver !
- Defects must be repaired and sources of interference must be removed immediately !
- A defective transmitter may only be repaired by qualified and competent personnel. Use only original HBC-radiomatic spare parts. The use of any other spares will render the technical inspectorate approval invalid as well as substantially impede operative safety.
- Observe all periodical tests and inspections that are required by law or recommended in the present operating instructions !
- When using the spectrum 1 M transmitter always observe the regulations and instructions stipulated in the authoritative worker safety and accident prevention regulations (VBG 9)
 - The spectrum 1 M transmitter has been manufactured in accordance with the regulations and guidelines stipulated in the German Trade Association's "Safety and Accident Prevention Regulations for Operating Cranes by Radio Controls" (VBG 9; ZH 1/547) and pr EN 12077-1.
 - The spectrum 1 M transmitter has been tested and approved in accordance with EMC guidelines and complies with the authoritative standards for emitted interference and interference immunity.
- Use the transmitter cautiously and properly. In particular when using a transmitter to radio control a machine or crane for the first time.



2.3 Operator Safety Instructions

- Before beginning crane operation, position yourself so that you have a clear and complete overview of the working radius of the crane or machine.
- To operate, hold the transmitter securely in your hand. Use the optional wrist strap. Follow these instructions to ensure personal safety.
- Depending on your angle or position to the crane or machine, the transmitter control commands "trolley left" and "trolley right" appear to interchange ! It is essential that you take your bearings to the crane or machine into due consideration before operating equipment.
- In case of an emergency or any disturbances within the working range of the crane or machine, switch the transmitter off immediately by pressing the STOP pushbutton. Should the transmitter show signs of technical failure or breakdown, disconnect the radio control system immediately !
- Switch the transmitter OFF during breaks and after finishing work to avoid any misoperation of crane or machine by unintended activation of the operator controls.
 - These precautions are particularly important whenever changing your position or climbing over an obstacle.
- Never leave an activated transmitter unattended. The operator undertakes to follow and comply with the authoritative regulations for worker safety and accident prevention (e.g. VBG 9).



Note :

- In the event of an interruption of the radio link during a working cycle – what can occasionally happen – both transmitter and receiver automatically shut down (so-called "**compulsory switch-off**").
To reactivate the system release all operator controls, such as pushbuttons or momentary contacts, and allow the control elements to return to their zero position. Press the "ON " pushbutton. The system must be reactivated before the crane or machine can react to control commands! This feature hinders any uncontrolled or unwanted crane or machine movement, should the radio link be interrupted.
- When operating a crane by means of a radio control system for the first time, you may miss the physical contact to the crane that you were used to in the operating stand. As you are no longer in the crane and can no longer sense the starting of the crane movements as distinctly, crane reactions will appear sluggish or dull.

3 Operation



Caution :

The operation of the transmitter is permissible only with the carrying set included with the transmitter (possibility of mixing up the operator controls) !

1. Before commissioning the transmitter or initial operation, insert a fully charged FuB 05 AA battery into battery compartment (pos. ①) at the bottom of the transmitter. The battery supplies the necessary working voltage (6 V DC).
2. Turn STOP pushbutton (pos. ②) to unlock.
3. Turn key switch (pos. ③) to the right (position "1" = ON).
4. Switch ON transmitter and crane or machine with "ON" pushbutton. The dual color LED (pos. ④) flashes **green**, i.e. the transmitter is operable.

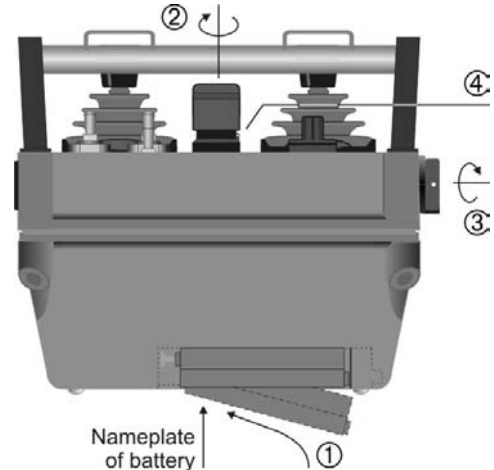

Important Information :

After switching ON the transmitter **and** before operating the crane or machine you must always :

- trigger the acoustic signal by pressing the "Horn" pushbutton. This warns all colleagues that the crane or machine is about to move;
- test the operativeness of the STOP pushbutton.

A radio connection to the receiver is established when the red LED "HF/RF/H.F./HF" on the receiver will be extinguished and the green LED "Si1" is illuminated (see radio status panel of the receiver), i.e. the radio system is ready to operate and the control commands may be input via the transmitter.

If the dual color LED on the transmitter flashes **red** and / or an acoustic signal comes, this indicates that the battery is almost fully discharged. Now, you must replace the discharged battery by a charged one and recharge the discharged battery (refer to chapter "Battery and Battery Charger").



Note :

If the discharged battery is not replaced by a charged one, the transmitter will be automatically switched OFF after a few minutes.

Should the operator – intentionally or unintentionally – switch OFF the transmitter with the STOP pushbutton, following steps have to be carried out for further radio transmission :

1. Switch OFF the transmitter via the key switch.
2. Unlock the STOP pushbutton by turning.
3. Switch the transmitter ON again via the key switch.



Note :

Always use the key switch to switch the transmitter ON or OFF. Do **not** use the STOP pushbutton !

Automatic Switch-OFF (APO Function)

For safety reasons we have equipped the transmitter with an automatic switch-OFF (APO = **A**utomatic **P**ower **O**ff function). The transmitter is automatically put out of circuit after 15 minutes of non-use.

The automatic switch-OFF also saves battery power.



Note :

The automatic switch-OFF (APO function) does not relieve the operator of his responsibility to turn OFF the transmitter when not in use !

The transmitter can be reactivate by means of the "ON" pushbutton.

Slewing Gear Release



Note :

This function is available only by radio control systems for construction cranes.

Whenever the command "slewing gear release" is actuated by means of the radio control, it is important that the respective check be made.

Due to the above, a clearly visible indicator lamp should be installed on the crane – possibly a flashing one.

3.1 Battery and Battery Charger

3.1.1 FuB 05 AA Transmitter Battery

The age and ambient temperature are decisive for the length of the battery applications. Older batteries lose capacity over time. Temperatures under zero also have a negative effect on battery charge.

The length of serviceable battery life depends on how the battery is treated. When handled properly the FuB 05 AA can exceed 500 charging cycles. Do not totally discharge or short-circuit contacts as this can permanently destroy the battery.

We recommend recharging the battery only when it is empty, i.e. when the red LED blinks or an acoustic signal sounds.

Always store rechargeable batteries at room temperature (20 °C or 68 °F).



3.1.2 FLG 105 Battery Charger

Recharging batteries

1. Connect battery charger to mains (refer to nameplate on battery charger for details).
2. Insert the adapter for the FuB 3A battery in the charging compartment of the battery charger.
3. Insert battery with the nameplate facing up into the battery compartment (pos. ②).

Charging indicator (red LED ; pos. ①)

LED lit: battery charging.

LED off or flashing: battery full, i.e. operable.

LED flashes

when inserting battery: battery totally discharged or defective.

Note :

- A discharged FuB 05 AA battery recharges in approx. 4 hours. Electronics in the battery charger ensure that charging does not exceed 5 hours.
- The quick charging of NiCd batteries should only take place at temperatures between +10 °C and +40 °C (50 °F and 104 °F).
- Protect battery contacts against short circuits. Never store batteries in a tool box or trouser pockets. A bunch of keys is enough to short the battery. Always use the protective cap included.
- Use the charger at room temperature (20 °C or 68 °F) and protect it from extreme heat (direct sun).



3.2 Special Operating Modes (Optional)



Note :

This chapter describes special operating modes that are not available with all crane systems.

If your radio control system is not equipped with the features described, you may ignore the following and continue with the next chapter.

3.2.1 Option Scanner (Frequency Selector)



Note :

This is a standard function by radio control systems for construction cranes (fig. below), and available as an option by radio control systems for industrial cranes.

The transmitter and receiver are equipped with a "Scanner" (frequency selector) operating mode with 4 radio frequencies (refer to wiring diagrams).

In the event that the momentarily used radio channel is being used by another operator, the transmitter can be switched over to a different channel by means of the rotary switch. The receiver scanner automatically adjusts the receiver to the selected radio frequency.

After turning ON the transmitter (set key switch to "ON" position and do not forget to unlock STOP pushbutton), the receiver automatically resets the system to the new frequency selected in less than a second.

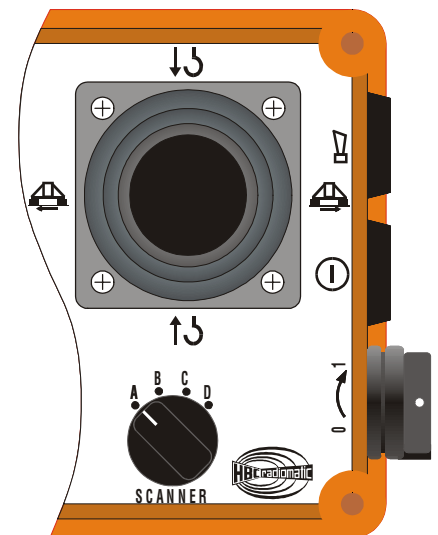

File: SP-1M_Layout-Bau_Scanner.CDR [CorelDraw 8.0] 27.09.2000 FL

3.2.2 Option "Pitch – Catch"

The "Pitch – Catch" operating mode allows two or more crane operators equipped with one transmitter each to independently use the same crane

The crane is equipped with a radio receiver that can receive and monitor transmitter frequencies. After activating the receiver all transmitters have equal access to the control system.

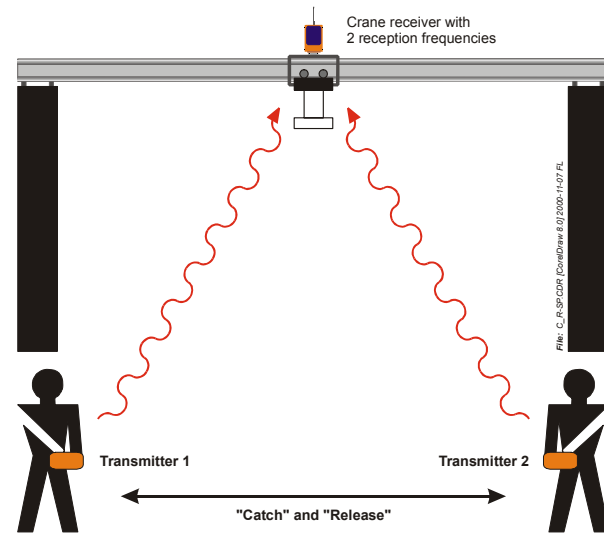

Releasing the crane ("Pitch")

To release the crane :

1. Enter the "pitch" command via the rotary switch or pushbutton on transmitter 1 or transmitter 2.
2. For safety reasons we recommend switching OFF transmitter 1 or transmitter 2. This will avoid operator errors.

This cancels the access rights of transmitter 1 or transmitter 2 to the crane.

Taking over control of the crane ("Catch")

To take over the control of the crane, enter the "catch" command via the rotary switch or pushbutton on transmitter 1 or transmitter 2.

The transmitter with control over the crane retains the access to the receiver (transmitter 1 or transmitter 2) until the operator has issued the "Pitch" statement.

Operating Example :

Transmitter 2 has control over the crane control system. Transmitter 1 is to be given control. The operators must continue as follows :

1. Enter the "pitch" command via the rotary switch or pushbutton on transmitter 2.
2. For safety reasons we recommend switching OFF transmitter 2, i.e. turn the key switch to the "0 = OFF" position.
3. Activate transmitter 1, i.e. turn the key switch to the "1 = ON" position.
4. Enter the "catch" command via the rotary switch or pushbutton on transmitter 1.

Transmitter 1 now has sole access to all crane functions.



Notes :

- A power loss at the receiver-end activates a general reset of the crane system. All transmitters have access to the crane radio controls. This implies that the pitch – catch settings must be readjusted at the transmitter-end.
- Should an operator forget to issue the "pitch" statement and shuts down his transmitter (transmitter shut down using the STOP pushbutton or technical failure) the second transmitter has no access to the crane radio control system. In order to give transmitter 2 access to the radio control system the receiver must be cut OFF from the supply voltage (master switch) and the crane control system reactivated as described above.
- The "pitch" and "catch" commands should therefore be laid on a rotary switch or a pushbutton. In addition, a lamp that can be mounted on the crane will indicate when the receiver is busy (busy display).

3.2.3 Option Tandem Operation

Tandem Operation T1

Parallel control of two cranes (2 receivers) on one radio frequency is possible with one radio transmitter using the option tandem operation "T1".

The individual cranes can be controlled using the rotary switch on the transmitter (fig. right, bottom).

The individual switching positions mean :

- A** Access to crane A
- A+B** Access to both cranes
- B** Access to crane B

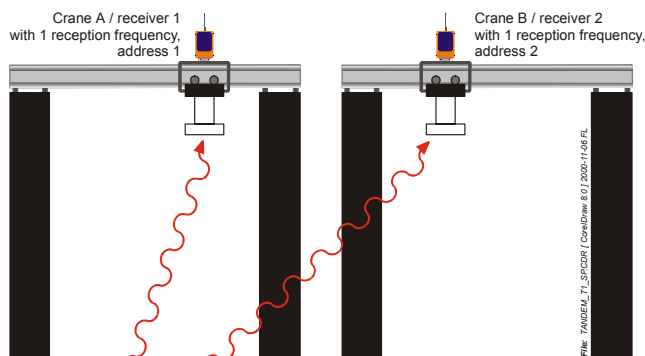

Transmitter 1



File: SP-1M_Layout-Industrie_Tandemf.CDR [CorelDraw 8.0] 27.09.2000 FL

Tandem Operation T2

Operation of two cranes is possible with two complete radio control systems (2 transmitters, 2 receivers) using the option tandem operation "T2", whereby each transmitter is a "master" transmitter.

The radio transmitter key for crane A can also be used to switch over the transmitter for crane A to crane B. To do this, the following steps must be carried out :

1. Remove the key from master transmitter 2. This switches OFF master transmitter 2.
2. Put the key from master transmitter 2 into master transmitter 1.
This activates the release for crane pre-selection in the transmitter.
- or**
3. Remove the key from master transmitter 1. This switches OFF master transmitter 1.
4. Put the key from master transmitter 1 into master transmitter 2.
This activates the release for crane pre-selection in the transmitter.
5. Select the corresponding crane by means of the rotary switch on the master transmitter 1 or master transmitter 2 : either crane A or crane A+B (both cranes) or crane B.
The corresponding cranes are now running in the pre-selected operation mode.

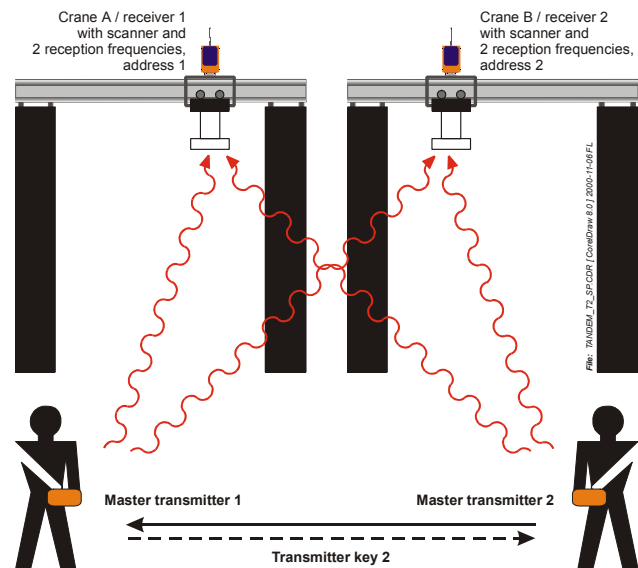

Note :

During tandem operation "T2", each transmitter is a "master" transmitter. It is possible, however, to operate only one "master" and one "slave" transmitter. In this case, only the "master" transmitter is able to control both cranes in tandem operation.

Tandem Operation TM / TS

Operation of two cranes is possible with two complete radio controls (2 transmitters, 2 receivers) using the option tandem operation "TM / TS", whereby one transmitter is a "master" and the other transmitter is a "slave".

The radio transmitter key for crane B can also be used to switch over the transmitter for crane A to crane B.

To do this, the following steps must be carried out :

1. Remove the key from the slave transmitter. This switches OFF the slave transmitter.
2. Put the key from slave transmitter into master transmitter. This activates the release for crane pre-selection in the transmitter.
3. Select the corresponding crane by means of the rotary switch on the master transmitter : either crane A or crane A+B (both cranes) or crane B. The corresponding cranes are now running in the pre-selected operation mode.

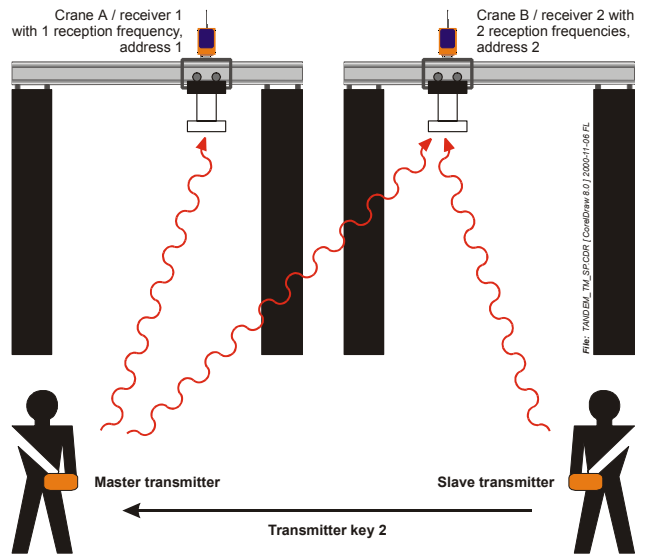

File: SP-1M_Layout-Industrie_Tandemf.CDR [CorelDraw 8.0] 27.09.2000 FL



Note :

To ensure safe operation during tandem operation "T2" **and** "TM / TS", it is imperatively required that **only one key** is available to the respective crane operators.

The extra key supplied with transmitter 2 must therefore be deposited at a superior, authoritative position and only be handed out in clarified cases

3.2.4 Option infrakey

infrakey is an additional infrared module for the transmitter and the receiver. Due to separate crane activation via infrared link it increases the safety of operation, i.e. the crane can not become inadvertently enabled.

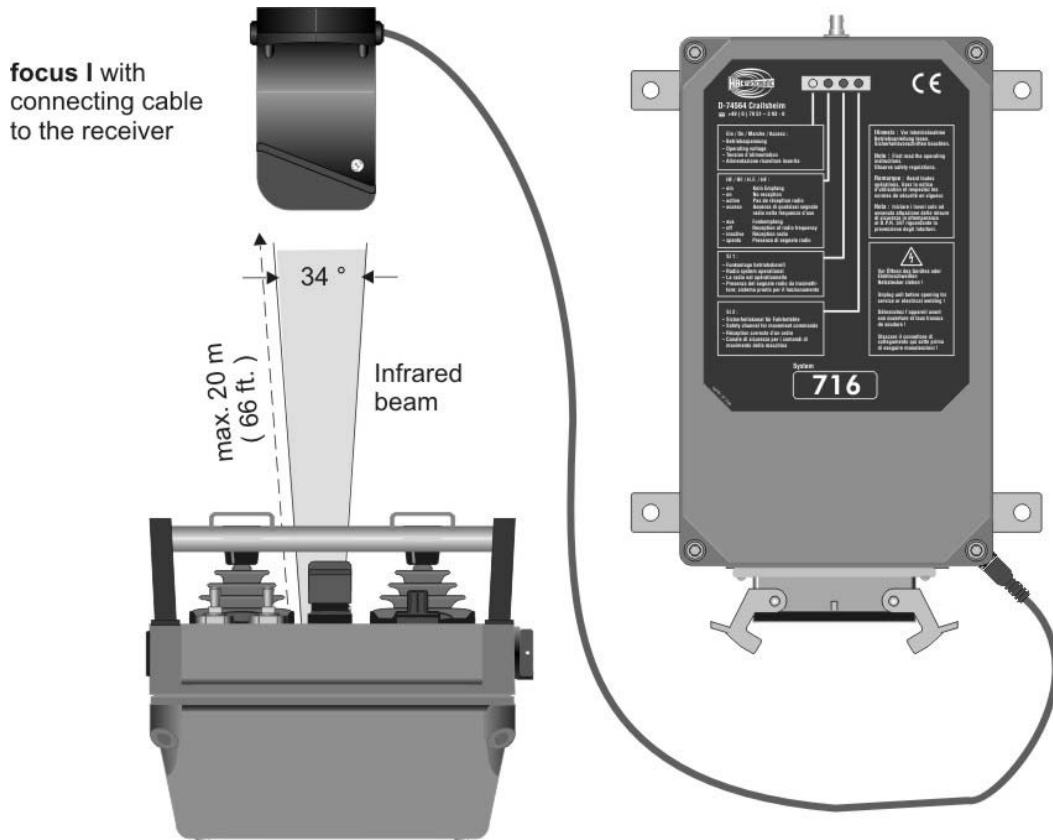

Function of **infrakey** (schematic view),
e.g. spectrum 1 M radio transmitter and FSE 716 radio receiver

The range of the infrared beam is max. approx. 20 meters (66 feet) and the angle of radiation is 34°.

To activate infrakey, press the "(Crane) On" pushbutton on the transmitter.

3.2.4.1 infrakey Set-up

Please follow these steps when replacing a focus I infrakey receiver, or up-grading an existing radio system with focus I:

1. Connect the focus I infrakey receiver to the radio receiver.
2. Insert a charged battery into the battery compartment of the transmitter.
3. Release the STOP-pushbutton on the transmitter (if locked) and turn on the transmitter using the key switch.
4. Press the set-up pushbutton ① on the focus I infrakey receiver until the LED ② blinks. Release the button.
5. Press the "(Crane) On" pushbutton on the transmitter until the LED ② on the focus I infrakey receiver blinks rapidly. Release the pushbutton and the LED will go off.
6. Affix the "INFRAKEY OK" sticker above the set-up pushbutton ①.



The focus I infrakey receiver can now recognize the transmitter's exclusive security telegram.

4 Fault Correction



Note :

Please check the transmitter functions using the cabin or cable controls first !

Problem	Possible Cause	Remedy
The transmitter does not react when switched on.	<ul style="list-style-type: none"> - There is no power. 	<ul style="list-style-type: none"> - Check the battery contacts for damage or contamination. - Insert a fully charged battery in battery compartment. - Recharge battery.
Low-power indicator blinks after minimal operating time, i.e. the dual color transmitter LED illuminates red.	<ul style="list-style-type: none"> - The battery contacts are contaminated or damaged. - The battery not charged. - The battery defective. 	<ul style="list-style-type: none"> - Check the battery contacts for damage or contamination. - Fully recharge the battery. - Ensure that the recharging process runs correctly. - Check the transmitter functions using a fully charged or replacement battery.

5 Maintenance

The radio control system is virtually maintenance-free. The following points, however, should be taken into consideration :

- Ensure that the STOP pushbutton works smoothly.
Mortar residue and contaminants of any kind can reduce or fully block the switch function.
- Inspect the rubber bellows of the compact joysticks regularly for leak-tightness.
Replace immediately if cracks appear since the penetration of dirt and humidity may damage the function of the compact joysticks.
- Charge and discharge transmitter batteries regularly.
- **Never** use a high-pressure cleaner or steam jet cleaner to "clean" the transmitter.
Use a soft brush or cloth only !



Note :

Should you have any problems with the radio control system, contact your local distributor or HBC-radiomatic GmbH.

5.1 In the Event of a Fault



Warning :

Never operate a crane or machine with a faulty or defective radio control system !

- Never try to repair the transmitter electronics ! Opening the transmitter housing terminates the manufacturer guarantee.
 - Send any defective or faulty equipment to you local distributor or to the manufacturer. They are experts and have the necessary know-how and OEM spare parts.
 - Always send both transmitter **and** receiver and enclose a detailed description of the problem.
 - Do not forget to enclose your address and telephone number so that we can get in touch with you quickly if necessary.
- To avoid damage during transport, use the original packing supplied with the transmitter and receiver, otherwise pack securely. Send the consignment to your distributor or to the following address :
HBC-radiomatic GmbH
Haller Strasse 49 – 53
D-74564 Crailsheim
- Should you chose to deliver a defective radio control system personally to your distributor or our factory, please call and arrange an appointment.
HBC-radiomatic GmbH
– Customer Services / Repair Service –
Tel.: +49 (0) 79 51 – 3 93 - 800

6 Technical Data

General Technical Data	
<i>System</i>	spectrum 1 M
<i>Number of control commands</i>	12, 16, 24 + STOP
<i>Unique system address</i>	over 65.000 combinations
Transmitter Specific Technical Data	
<i>Transmitting power with</i>	
<i>FuS 671/3</i>	< 10 mW (synthesizer)
<i>FuS 680/3</i>	< 5 mW (synthesizer)
<i>Transmitter antenna</i>	internal
<i>Battery type</i>	FuB 05 AA (orange)
<i>Power supply with NiCd battery</i>	6 V DC / 600 mAh
<i>Battery charge at 100 % duty cycle</i>	approx. 12 h
<i>Operating temperature range</i>	-25 °C ... +75 °C (-13 °F ... +167 °F)
<i>Housing material</i>	impact resistant plastic
<i>Housing color</i>	orange
<i>Housing dimensions</i>	212 x 160 x 185 mm (8.3 x 6.3 x 7.3 ")
<i>Weight</i>	approx. 2,0 kg (4.4 lb.)
<i>Protection class</i>	IP 55 (Nema 4)

6.1 Dimensions and Operating Elements of spectrum 1 M

6.1.1 Industrial Version

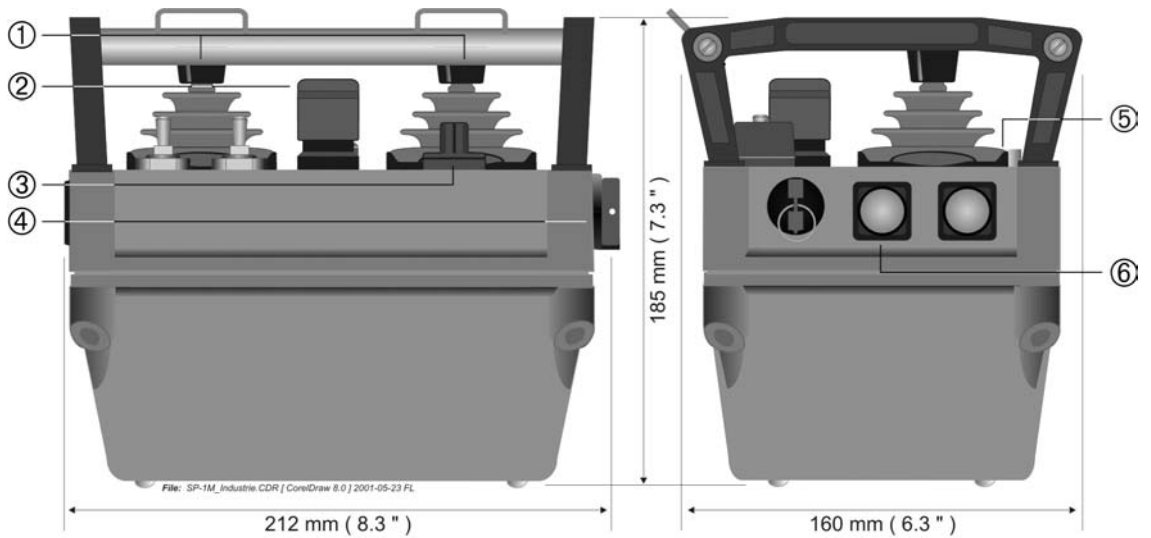

- ① Compact joysticks
- ② STOP pushbutton
- ③ Rotary switch
- ④ Key switch "Transmitter ON"

- ⑤ Dual color LED
 - green = "Transmitter ON"
 - red = "Charge battery"
- ⑥ Main contact "Start"



6.1.2 Constructional Version

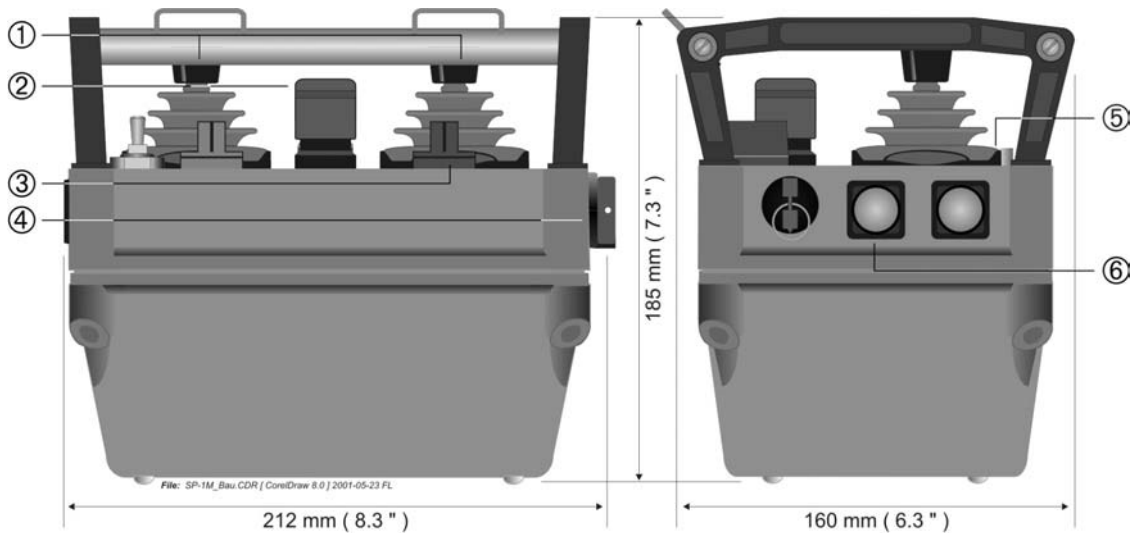

- | | |
|--|--|
| <ul style="list-style-type: none"> ① Compact joysticks ② STOP pushbutton ③ Rotary switch (frequency selection) ④ Key switch "Transmitter ON" | <ul style="list-style-type: none"> ⑤ Dual color LED
– green = "Transmitter ON"
– red = "Charge battery" ⑥ Main contact "Start" |
|--|--|

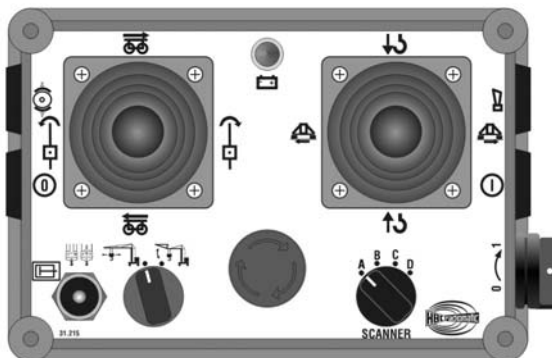

7 Certification and Approvals

EC Declaration of the Manufacturer and of Conformity

according to EC Directives for Machinery 98/37/EG , Appendix II B

We,

HBC-radiomatic GmbH
Haller Strasse 49-53 • 74564 Crailsheim • GERMANY

hereby certify that the following products



Radio Control Transmitter orbit, vector, patrol, micron, eco, spectrum, geo
Radio Control Receiver 505, 514, 707, 716, 717, 722, 735, 770, 808

correspond to the following EC guidelines

98/37/EG Directives for machinery
..... (altered by 91/263/EWG, 92/31/EWG, 93/68/EWG)
73/23/EWG Directives for low voltages (altered by 93/68/EWG)
1999/5/EG Radio and Telecommunications Terminal Equipment Act
..... (FTEG)

In particular, the tests executed were based on the following harmonized standards

EN 300 220 EMC - emission
EN 300 683 EMC – immunity
EN 954-1:1996 Safety of machinery;
..... Safety relevant parts of controls
EN 60529 Degree of protection provided by enclosure (IP)
IEC 68 Mechanical strength
prEN 50178 Climatic tests
DIN V VDE 0801 appendix 1 ... Principles for computers in safety-related systems

and on the following national technical standards :

ZH 1/547:1976 Directives for radio controls of cranes
ZH 1/295:1995 Safety regulations for wireless control facilities

Note : **The commissioning of the machine on which this part of the machine was installed is prohibited until it has been established that the machine corresponds to the 98/37/EG Directives.**

Authorized by :

Name, first name: Brendel, Wolfgang

Position in the company : General Manager

Location and date : Crailsheim, November 23, 2001

Authentic signature :

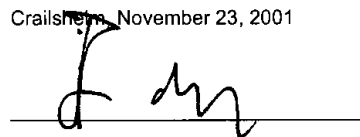



Operating Instructions *Radio Transmitter spectrum 1 M*