



FCC TEST REPORT

47 CFR FCC Part 15.249

Report Reference No.....	WE11070023	
FCC ID.....	NMTBPW800	
Compiled by (position+printed name+signature)...	File administrators Wenliang Li	
Supervised by (position+printed name+signature)...	Test Engineer Tim Zhang	
Approved by (position+printed name+signature)...	Manager Jeffrey Lu	
Date of issue.....	Aug 03, 2011	
Testing Laboratory Name.....	Shenzhen Huatongwei International Inspection Co., Ltd	
Address.....	Keji Nan No.12 Road, Hi-tech Park, Shenzhen, China	
Applicant's name.....	IDT Technology Limited	
Address.....	Block C, 9/F.,Kaiser Estate, Phase 1, 41 Man Yue Street,Hunghom, Kowloon, Hong Kong	
Manufacturer's name.....	IDT Technology Limited	
Address.....	Chentian Industrial Estate,Xixiang,Bao An,Shenzhen, PRC	
Test specification:		
Standard.....	47 CFR FCC Part 15 Subpart C & 15.249 ANSI C63.10: 2009	
TRF Originator.....	Shenzhen Huatongwei International Inspection CO., Ltd	
Master TRF.....	Dated 2006-06	
Shenzhen Huatongwei International Inspection Co., Ltd. All rights reserved.		
This publication may be reproduced in whole or in part for non-commercial purposes as long as the Shenzhen Huatongwei International Inspection Co., Ltd is acknowledged as copyright owner and source of the material. Shenzhen Huatongwei International Inspection Co., Ltd takes no responsibility for and will not assume liability for damages resulting from the reader's interpretation of the reproduced material due to its placement and context.		
Equipment Under Test.....	Blood Pressure Wrist	
Trade Mark.....	/	
Model/Type reference.....	BPW800	
Listed Models.....	/	
Result.....	Complied	

TEST REPORT

Test Report No. :	WE11070023	Aug 03, 2010 Date of issue
--------------------------	-------------------	-------------------------------

Equipment under Test : Blood Pressure Wrist

Model /Type : BPW800

Listed Models : /

Applicant : IDT Technology Limited.

Address : Block C, 9/F.,Kaiser Estate, Phase 1, 41 Man Yue Street,Hunghom, Kowloon, Hong Kong

Manufacturer : IDT Technology Limited.

Address : Chentian Industrial Estate,Xixiang,Bao An,Shenzhen, PRC

Test Result according to the standards on page 4:	Positive
--	-----------------

The test report merely corresponds to the test sample.
It is not permitted to copy extracts of these test result without the written permission of the test laboratory.

Contents

- 1. TEST STANDARDS 4**

- 2. SUMMARY 5**
 - 2.1. General Remarks 5
 - 2.2. Equipment Under Test 5
 - 2.3. Short description of the Equipment under Test (EUT) 5
 - 2.4. EUT operation mode 5
 - 2.5. Related Submittal(s) / Grant (s) 5
 - 2.6. Modifications 5

- 3. TEST ENVIRONMENT 6**
 - 3.1. Address of the test laboratory 6
 - 3.2. Test Facility 6
 - 3.3. Statement of the measurement uncertainty 7
 - 3.4. Summary of standards and result 7
 - 3.5. Environmental conditions 8
 - 3.6. Equipments Used during the Test 8

- 4. TEST CONDITIONS AND RESULTS 9**
 - 4.1. ANTENNA REQUIREMENT 9
 - 4.2. Conducted Emissions Test 10
 - 4.3. Radiated Emission Test 11
 - 4.4. Out of band emissions 16
 - 4.5. 20dB Bandwidth Measurement 18

- 5. TEST SETUP PHOTOS OF THE EUT 19**

- 6. EXTERNAL AND INTERNAL PHOTOS OF THE EUT 21**

1. TEST STANDARDS

The tests were performed according to following standards:

[47 CFR FCC Rules Part 15.249](#): Frequency Hopping, Direct Spread Spectrum and Hybrid Systems that are in operation within the bands of 902-928 MHz, 2400-2483.5 MHz, 5725-5850 MHz and 24.0 - 24.25 GHz.

[ANSI C63.10: 2009](#) – American National Standard for Testing Unlicensed Wireless Devices

2. SUMMARY

2.1. General Remarks

Date of receipt of test sample : Jul 21, 2011

Testing commenced on : Jul 21, 2011

Testing concluded on : Aug 03, 2011

2.2. Equipment Under Test

Power supply system utilised

Power supply voltage : 120V / 60 Hz 115V / 60Hz
 12 V DC 24 V DC
 Other (specified in blank below)

DC 3V from Battery

2.3. Short description of the Equipment under Test (EUT)

2.45GHz (Transmitter) For more details, refer to the user's manual of the EUT.

Serial number: Prototype

2.4. EUT operation mode

The EUT has been tested under typical operating condition.

2.5. Related Submittal(s) / Grant (s)

This submittal(s) (test report) is intended for FCC ID: **NMTBPW800** filing to comply with Section 15.249 of the FCC Part 15, Subpart C Rules.

2.6. Modifications

No modifications were implemented to meet testing criteria.

3. TEST ENVIRONMENT

3.1. Address of the test laboratory

Shenzhen Huatongwei International Inspection Co., Ltd
Keji Nan No.12 Road, Hi-tech Park, Shenzhen, China
Phone: 86-755-26715686 Fax: 86-755-26748089

The sites are constructed in conformance with the requirements of ANSI C63.7, ANSI C63.4 (2009) and CISPR Publication 22.

3.2. Test Facility

The test facility is recognized, certified, or accredited by the following organizations:

CNAS-Lab Code: L1225

Shenzhen Huatongwei International Inspection Co., Ltd has been assessed and proved to be in compliance with CNAS-CL01 Accreditation Criteria for Testing and Calibration Laboratories (identical to ISO/IEC 17025: 2005 General Requirements) for the Competence of Testing and Calibration Laboratories, Date of Registration: August 02, 2007. Valid time is until March 29, 2012.

A2LA-Lab Cert. No. 2243.01

Shenzhen Huatongwei International Inspection Co., Ltd, EMC Laboratory has been accredited by A2LA for technical competence in the field of electrical testing, and proved to be in compliance with ISO/IEC 17025: 2005 General Requirements for the Competence of Testing and Calibration Laboratories and any additional program requirements in the identified field of testing. Valid time to Sep 30, 2011.

FCC-Registration No.: 662850

Shenzhen Huatongwei International Inspection Co., Ltd, EMC Laboratory has been registered and fully described in a report filed with the FCC (Federal Communications Commission). The acceptance letter from the FCC is maintained in our files. Registration 662850, Renewal date July 01, 2009.

IC-Registration No.: 5377

The 3m Alternate Test Site of Shenzhen Huatongwei International Inspection Co., Ltd has been registered by Certification and Engineering Bureau of Industry Canada for the performance of radiated measurements with Registration No. 5377 on Jan 24th, 2014.

ACA

Shenzhen Huatongwei International Inspection Co., Ltd, EMC Laboratory can also perform testing for the Australian C-Tick mark as a result of our A2LA accreditation.

NEMKO-Aut. No.: ELA125

Shenzhen Huatongwei International Inspection Co., Ltd has been assessed the quality assurance system, the testing facilities, qualifications and testing practices of the relevant parts of the organization. The quality assurance system of the Laboratory has been validated against ISO/IEC 17025:2005 or equivalent. The laboratory also fulfils the conditions described in Nemko Document NLA-10, the Authorization is valid through July 07, 2014.

VCCI

The 3m Semi-anechoic chamber (12.2m×7.95m×6.7m) and Shielded Room (8m×4m×3m) of Shenzhen Huatongwei International Inspection Co., Ltd has been registered in accordance with the Regulations for Voluntary Control Measures with Registration No.: R-2484. Date of Registration: December 20, 2009. Valid time is until December 19, 2012.

Main Ports Conducted Interference Measurement of Shenzhen Huatongwei International Inspection Co., Ltd has been registered in accordance with the Regulations for Voluntary Control Measures with Registration No.: C-2726. Date of Registration: December 20, 2009. Valid time is until December 19, 2012.

DNV

Shenzhen Huatongwei International Inspection Co Ltd has been found to comply with the requirements of DNV towards subcontractor of EMC and safety testing services in conjunction with the EMC and Low voltage Directives and in the voluntary field. The acceptance is based on a formal quality Audit and follow-ups according to relevant parts of ISO/IEC Guide 17025(2005), in accordance with the requirements of the DNV Laboratory Quality Manual towards subcontractors. Valid time is until 24 Aug, 2013.

3.3. Statement of the measurement uncertainty

The data and results referenced in this document are true and accurate. The reader is cautioned that there may be errors within the calibration limits of the equipment and facilities. The measurement uncertainty was calculated for all measurements listed in this test report acc. to CISPR 16 - 4 „Specification for radio disturbance and immunity measuring apparatus and methods – Part 4: Uncertainty in EMC Measurements“ and is documented in the Shenzhen Huatongwei International Inspection Co., Ltd quality system acc. to DIN EN ISO/IEC 17025. Furthermore, component and process variability of devices similar to that tested may result in additional deviation. The manufacturer has the sole responsibility of continued compliance of the device.

Hereafter the best measurement capability for Shenzhen Huatongwei laboratory is reported:

Test Item	Frequency Range	Measurement Uncertainty	Notes
Radiated Emission	0.09~30MHz	3.85dB	(1)
Radiated Emission	30~1000MHz	4.22dB	(1)
Radiated Emission	1~12.75GHz	4.35dB	(1)
99% Bandwidth	/	0.25dB	(1)
Deactivation Time	/	0.5ms	(1)

- (1) This uncertainty represents an expanded uncertainty expressed at approximately the 95% confidence level using a coverage factor of k=2.

3.4. Summary of standards and result

FCC Rules	Description of Test	Result
§15.203	Antenna Requirement	Compliance
§15.109, §15.205(a), §15.209(a), 15.249(a), §15.249(c), §15.35	Radiated Emissions	Compliance
§15.249(d)	Out of Band Emissions	Compliance
§15.215(c)	20 dB Bandwidth	Compliance

- NOTE: 1) The detailed test result please see section 4.
 2) The test report merely corresponds to the test sample.
 3) It is not permitted to copy extracts of these test result without the written permission of the test laboratory.

3.5. Environmental conditions

During the measurement the environmental conditions were within the listed ranges:

Temperature: 15-35 ° C

Humidity: 30-60 %

Atmospheric pressure: 950-1050mbar

3.6. Equipments Used during the Test

Radiated Emissions / Out of Band Emissions					
Item	Test Equipment	Manufacturer	Model No.	Serial No.	Last Cal.
1	Loop Antenna	ROHDE & SCHWARZ	HFH2-Z2	100020	2010/10/24
2	Ultra-Broadband Antenna	ROHDE & SCHWARZ	HL562	100015	2010/10/24
3	Double-Ridged-Waveguide Horn Antenna	ROHDE & SCHWARZ	HF906	100039	2010/10/24
4	Horn Antenna	SCHWARZBECK	BBHA9170	25841	2010/10/24
5	EMI TEST RECEIVER	ROHDE & SCHWARZ	ESI 26	100009	2010/10/24
6	RF TEST PANEL	ROHDE & SCHWARZ	TS / RSP	335015/ 0017	2010/10/24
7	TURNTABLE	ETS	2088	2149	2010/10/24
8	ANTENNA MAST	ETS	2075	2346	2010/10/24
9	EMI TEST SOFTWARE	ROHDE & SCHWARZ	ESK1	N/A	2010/10/24

20 dB Bandwidth					
Item	Test Equipment	Manufacturer	Model No.	Serial No.	Last Cal.
1	EMI TEST RECEIVER	ROHDE & SCHWARZ	ESCI	100106	2010/10/24

4. TEST CONDITIONS AND RESULTS

4.1. ANTENNA REQUIREMENT

According to FCC Part 15C § 15.203,

- a), An intentional radiator shall be de-signed to ensure that no antenna other than that furnished by the responsible party shall be used with the device.
- b), The manufacturer may design the unit so that a broken antenna can be replaced by the user, but the use of a standard antenna jack or electrical connector is prohibited.

The EUT use of a Integral antenna. Please refer to the EUT Internal photos.

The EUT complied the antenna requirement.

Please refer to the EUT photos.

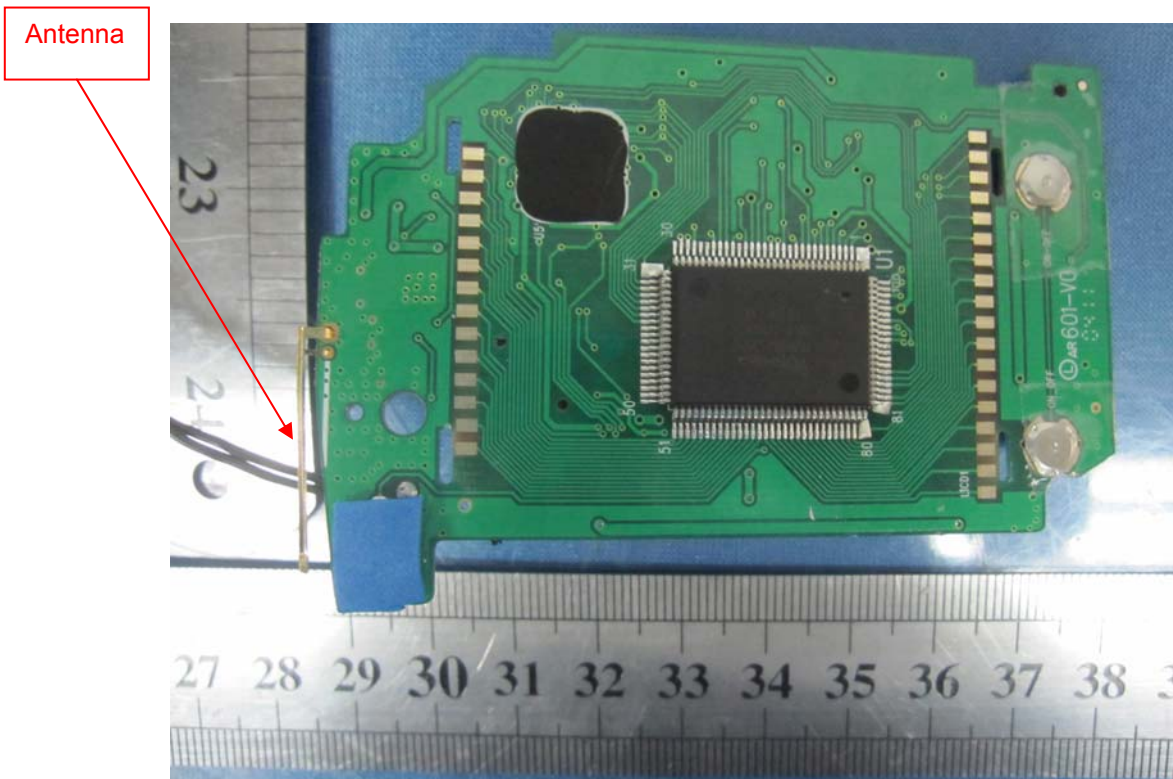

4.2. Conducted Emissions Test

TEST CONFIGURATION

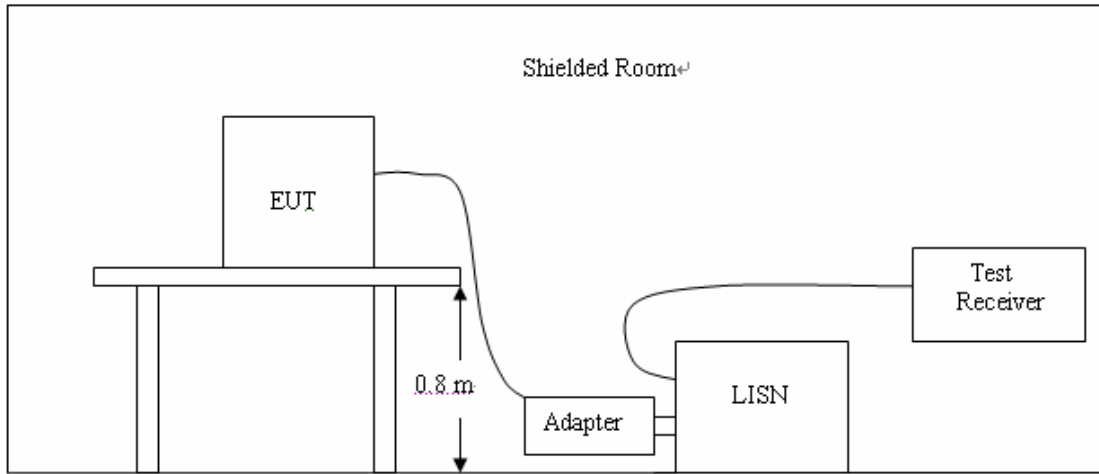

TEST PROCEDURE

- 1 The equipment was set up as per the test configuration to simulate typical actual usage per the user's manual. The EUT is a Weather station Transmitter; a wooden table with a height of 0.8 meters is used and is placed on the ground plane as per ANSI C63.10.
- 2 Support equipment, if needed, was placed as per ANSI C63.10.
- 3 All I/O cables were positioned to simulate typical actual usage as per ANSI C63.10.
- 4 All support equipments received AC power from a second LISN, if any.
- 5 The EUT test program was started. Emissions were measured on each current carrying line of the EUT using a spectrum Analyzer / Receiver connected to the LISN powering the EUT. The LISN has two monitoring points: Line 1 (Hot Side) and Line 2 (Neutral Side). Two scans were taken: one with Line 1 connected to Analyzer / Receiver and Line 2 connected to a 50 ohm load; the second scan had Line 1 connected to a 50 ohm load and Line 2 connected to the Analyzer / Receiver.
- 6 Analyzer / Receiver scanned from 150 KHz to 30MHz for emissions in each of the test modes.
- 7 During the above scans, the emissions were maximized by cable manipulation.

CONDUCTED LIMIT

According to FCC Subpart 15 B § 15.207 AC Conducted Emission Limits is as following :

Frequency fange (MHz)	Conducted limit (dB μ V)	
	Quasi-peak	Average
0.1~ 0.5	66 to 56*	56 to 46*
0.5 ~ 5	56	46
5 ~ 30	60	50

* Decreasing linearly with the logarithm of the frequency

TEST RESULTS

Not applicable to this device (because the equipment without any AC port)

4.3. Radiated Emission Test

TEST CONFIGURATION

Radiated Emission Test Set-Up

Frequency range 9KHz – 30MHz

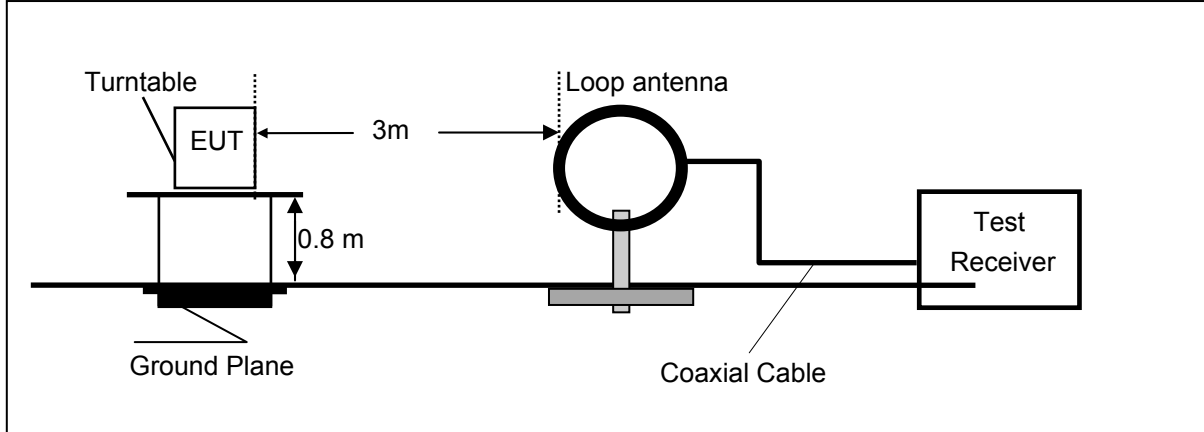

Frequency range 30MHz – 1000MHz

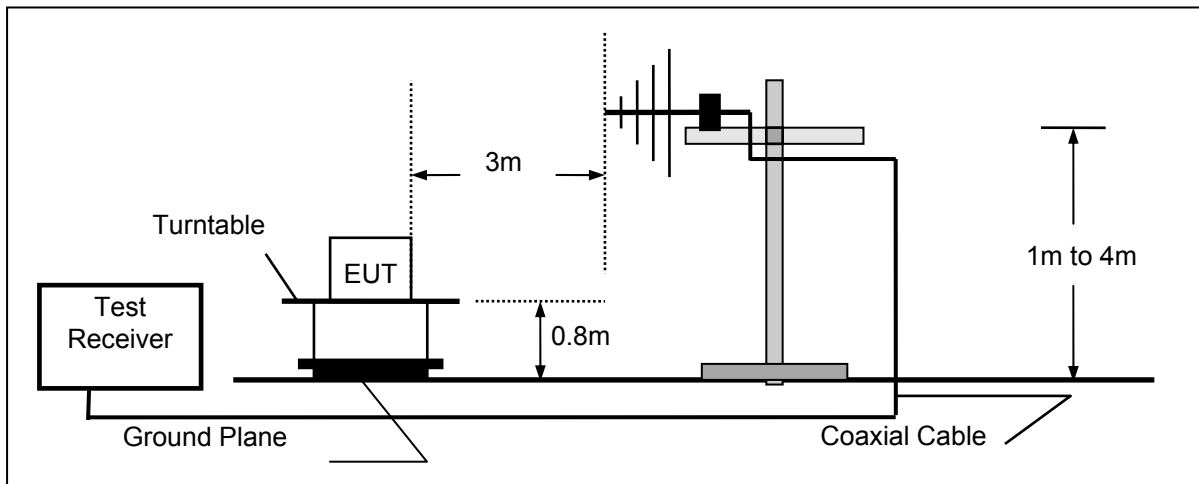

Frequency range above 1GHz-25GHz

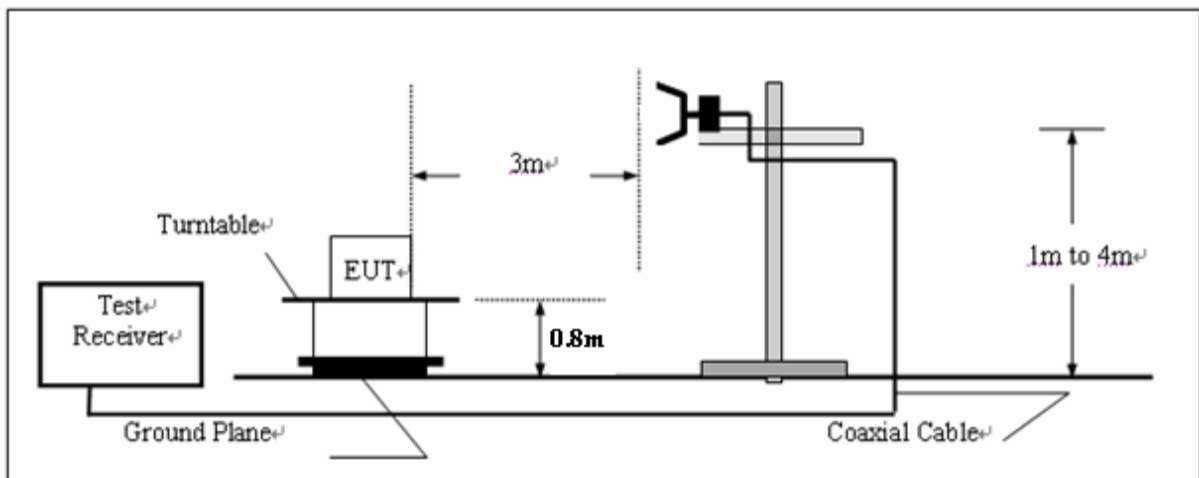

TEST PROCEDURE

1. The EUT is placed on a turntable, which is 0.8m above ground plane.
2. The turntable shall be rotated for 360 degrees to determine the position of maximum emission level.
3. EUT is set 3m away from the receiving antenna, which is varied from 1m to 4m to find out the highest emissions.
4. Maximum procedure was performed on the six highest emissions to ensure EUT compliance.
5. And also, each emission was to be maximized by changing the polarization of receiving antenna both horizontal and vertical.
6. Repeat above procedures until the measurements for all frequencies are complete.
7. the fundamental frequency is 2.45GHz and the lowest crystal frequency is 32.768KHz, So the radiation emissions frequency range were tested from 9KHz to 25GHz.

RADIATION LIMIT

For unintentional device, according to § 15.109(a), except for Class A digital devices, the field strength of radiated emissions from unintentional radiators at a distance of 3 meters shall not exceed the following values:

Frequency (MHz)	Distance (Meters)	Radiated (dB μ V/m)	Radiated (μ V/m)
30-88	3	40.0	100
88-216	3	43.5	150
216-960	3	46.0	200
Above 960	3	54.0	500

For intentional device, according to § 15.209(a), the general requirement of field strength of radiated emissions from intentional radiators at a distance of 3 meters shall not exceed the above table.

As per §15.249 (a), except as provided in paragraph (b) of this section, the field strength of emissions from intentional radiators operated within these frequency bands shall comply with the following:

Fundamental frequency	Field strength of fundamental (millivolts/meter)	Field strength of harmonics (microvolts/meter)
902–928 MHz	50	500
2400–2483.5 MHz	50	500
5725–5875 MHz	50	500
24.0–24.25 GHz	250	2500

As per §15.249 (c), Field strength limits are specified at a distance of 3 meters.

TEST RESULTS

Radiated emission (30MHz-1000MHz)

SHENZHEN HUATONGWEI INTERNATIONAL INSPECTION CO.,LTD

RADIATED EMISSION FCC PART 15

EUT: Blood Pressure Wrist M/N:BPW800
 Manufacturer: IDT Technology Limited
 Operating Condition: Running
 Test Site: 3M CHAMBER
 Operator: FIYO
 Test Specification: DC 3V
 Comment:
 Start of Test: 7/25/2011 / 8:30:52AM

SCAN TABLE: "test (30M-1G)"

Short Description:		Field Strength			
Start	Stop	Detector	Meas. Time	IF Bandw.	Transducer
30.0 MHz	1.0 GHz	QP	Coupled	120 kHz	HL562

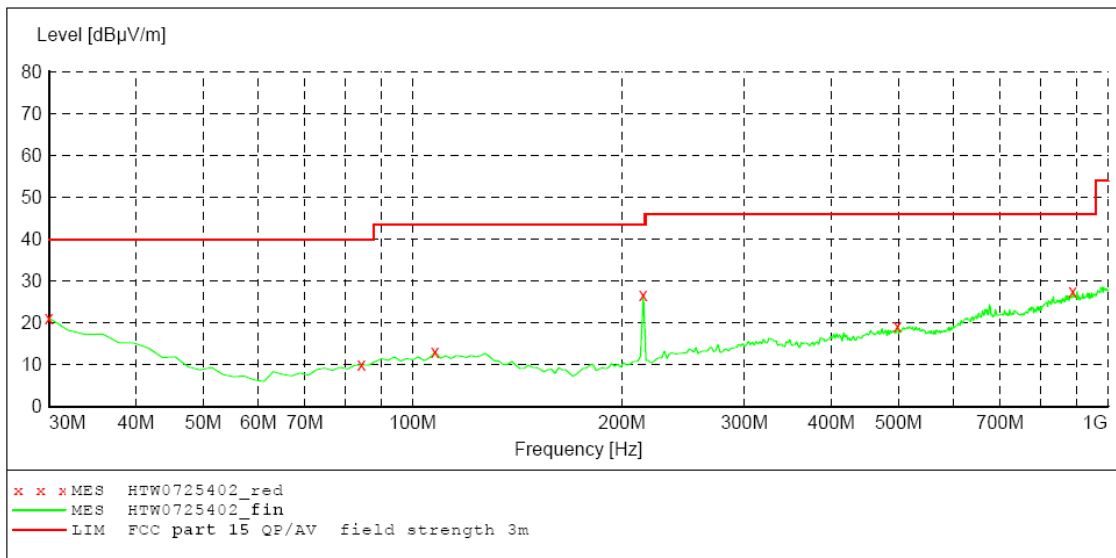

MEASUREMENT RESULT: "HTW0725402_fin"

7/25/2011 8:32AM

Frequency MHz	Level dBµV/m	Transd dB	Limit dBµV/m	Margin dB	Det.	Height cm	Azimuth deg	Polarization
30.000000	21.10	-11.5	40.0	18.9	QP	100.0	53.00	HORIZONTAL
84.428858	10.00	-21.5	40.0	30.0	QP	300.0	155.00	HORIZONTAL
107.755511	13.10	-20.1	43.5	30.4	QP	100.0	136.00	HORIZONTAL
214.669339	26.70	-21.3	43.5	16.8	QP	300.0	175.00	HORIZONTAL
498.476954	19.20	-14.6	46.0	26.8	QP	300.0	7.00	HORIZONTAL
891.142285	27.50	-7.1	46.0	18.5	QP	100.0	0.00	HORIZONTAL

SHENZHEN HUATONGWEI INTERNATIONAL INSPECTION CO.,LTD

RADIATED EMISSION FCC PART 15

EUT: Blood Pressure Wrist M/N:BPW800
 Manufacturer: IDT Technology Limited
 Operating Condition: Running
 Test Site: 3M CHAMBER
 Operator: FIYO
 Test Specification: DC 3V
 Comment:
 Start of Test: 7/25/2011 / 8:33:20AM

SCAN TABLE: "test (30M-1G)"

Short Description:		Field Strength				Transducer
Start	Stop	Detector	Meas. Time	IF Bandw.		
30.0 MHz	1.0 GHz	QP	Coupled	120 kHz	HL562	

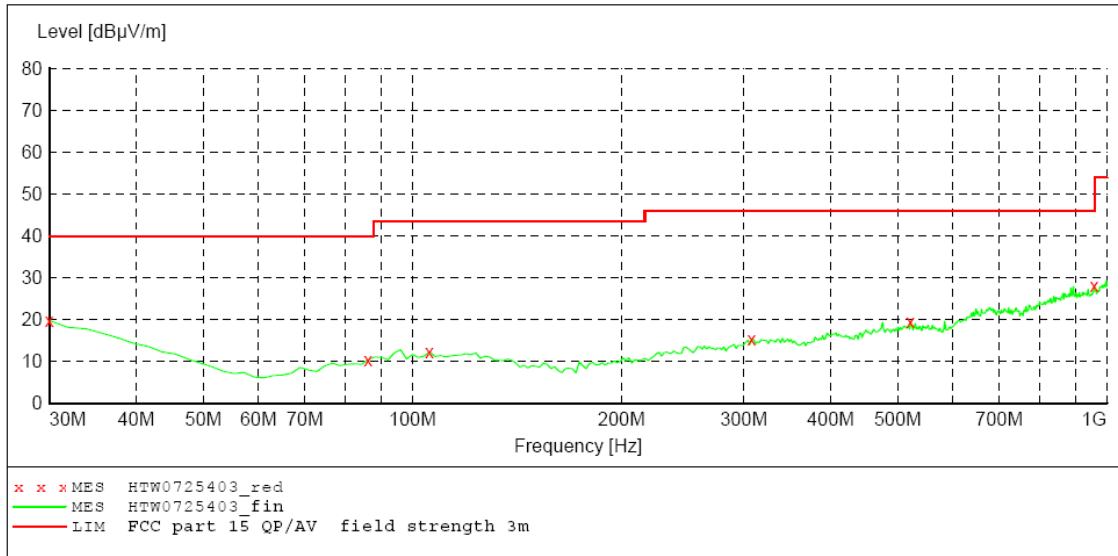

MEASUREMENT RESULT: "HTW0725403_fin"

7/25/2011 8:34AM

Frequency MHz	Level dBµV/m	Transd dB	Limit dBµV/m	Margin dB	Det.	Height cm	Azimuth deg	Polarization
30.000000	19.70	-11.5	40.0	20.3	QP	100.0	272.00	VERTICAL
86.372745	10.40	-21.2	40.0	29.6	QP	100.0	323.00	VERTICAL
105.811623	12.30	-20.2	43.5	31.2	QP	100.0	313.00	VERTICAL
307.975952	15.40	-17.2	46.0	30.6	QP	100.0	113.00	VERTICAL
521.803607	19.40	-14.0	46.0	26.6	QP	100.0	209.00	VERTICAL
959.178357	28.10	-6.7	46.0	17.9	QP	100.0	249.00	VERTICAL

Radiated emission of fundamental emission

Frequency (MHz)	Corrected Reading (dB μ V/m)@3m	FCC Limit (dB μ V/m) @3m	Margin (dB)	Detector	Polarization
2450	81.05	114	32.95	PK	Horizontal
2450	70.26	94	23.74	AV	Horizontal
2450	86.37	114	27.63	PK	Vertical
2450	74.72	94	19.28	AV	Vertical

Spurious radiated emission

Frequency (MHz)	Corrected Reading (dB μ V/m)@3m	FCC Limit (dB μ V/m) @3m	Margin (dB)	Detector	Polarization
16	31.99	69.54	37.55	QP	/
4900.24	53.30	74	20.70	PK	Horizontal
4900.24	42.16	54	11.84	AV	Horizontal
7350.58	51.03	74	22.97	PK	Horizontal
7350.58	40.04	54	13.96	AV	Horizontal
4900.24	56.07	74	17.93	PK	Vertical
4900.24	43.27	54	10.73	AV	Vertical
7350.58	52.49	74	21.51	PK	Vertical
7350.58	40.86	54	13.14	AV	Vertical

4.4. Out of band emissions

TEST PROCEDURE

The band edge compliance of RF radiated emission should be measured by following the guidance in ANSI C63.4 with respect to maximizing the emission by rotating the EUT, measuring the emission while the EUT is situated in three orthogonal planes (if appropriate), adjusting the measurement antenna height and polarization etc. Set RBW to 1MHz and VBM to 3MHz to measure the peak field strength and set RBW to 1MHz and VBW to 10Hz to measure the average radiated field strength.

The conducted RF band edge was measured by using a spectrum analyzer. Set span wide enough to capture the highest in-band emission and the emission at the band edge. Set RBW to 100 KHz and VBM to 300 KHz, to measure the conducted peak band edge.

EUT Setup

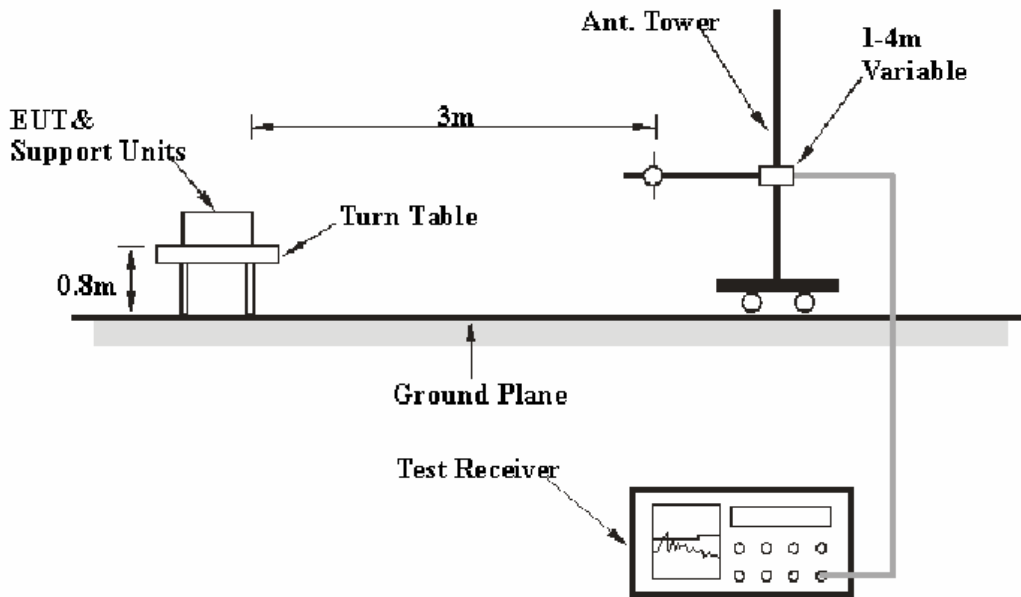

LIMIT

FCC PART 15.249(d) Emissions radiated outside of the specified frequency bands, except for harmonics, shall be attenuated by at least 50 dB below the level of the fundamental or to the general radiated emission limits in §15.209, whichever is the lesser attenuation.

TEST RESULTS

Test Mode: Transmitting

Frequency (MHz)	Corrected Reading (dBµV/m)@3m	FCC Limit (dBµV/m) @3m	Margin (dB)	Detector	Polarization
Out of left side band					
2389.04	41.56	74	32.44	PK	Horizontal
2389.04	31.25	54	22.75	AV	Horizontal
2383.59	40.43	74	33.57	PK	Vertical
2383.59	30.67	54	23.33	AV	Vertical
Out of right side band					
2490.97	42.67	74	31.33	PK	Horizontal
2490.97	31.24	54	22.76	AV	Horizontal
2499.87	42.91	74	31.09	PK	Vertical
2499.87	31.69	54	22.31	AV	Vertical

Note:

1. The field strength of any emissions which appear outside of this band shall not exceed the general radiated emission limits in Section 15.209.
2. The average measurement was not performed when the peak measured data under the limit of average detection.

4.5. 20dB Bandwidth Measurement

TEST CONFIGURATION

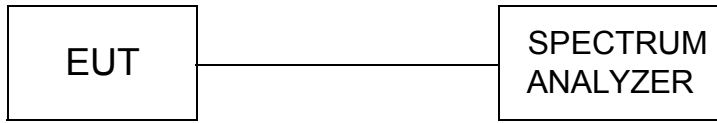

TEST PROCEDURE

The transmitter output is connected to the spectrum analyzer. The spectrum analyzer center frequency is set to the transmitter frequency. The RBW is set to 100 KHz and VBW is set 300 KHz.

LIMIT

Intentional radiators operating under the alternative provisions to the general emission limits, as contained in §§ 15.217 through 15.257 and in Subpart E of this part, must be designed to ensure that the 20 dB bandwidth of the emission, or whatever bandwidth may otherwise be specified in the specific rule section under which the equipment operates, is contained within the frequency band designated in the rule section under which the equipment is operated.

The 20dB bandwidth shall be no wider than 0.25% of the centre frequency for devices operating between 70-900 MHz. For devices operating above 900 MHz, the emission shall be no wider than 0.5% of the centre frequency.

TEST RESULTS

20dB Bandwidth Measurement Result			
Operating Frequency	Test Data(MHz)	Limits(MHz)	Result
2.45GHz	0.3467	12.25	PASS

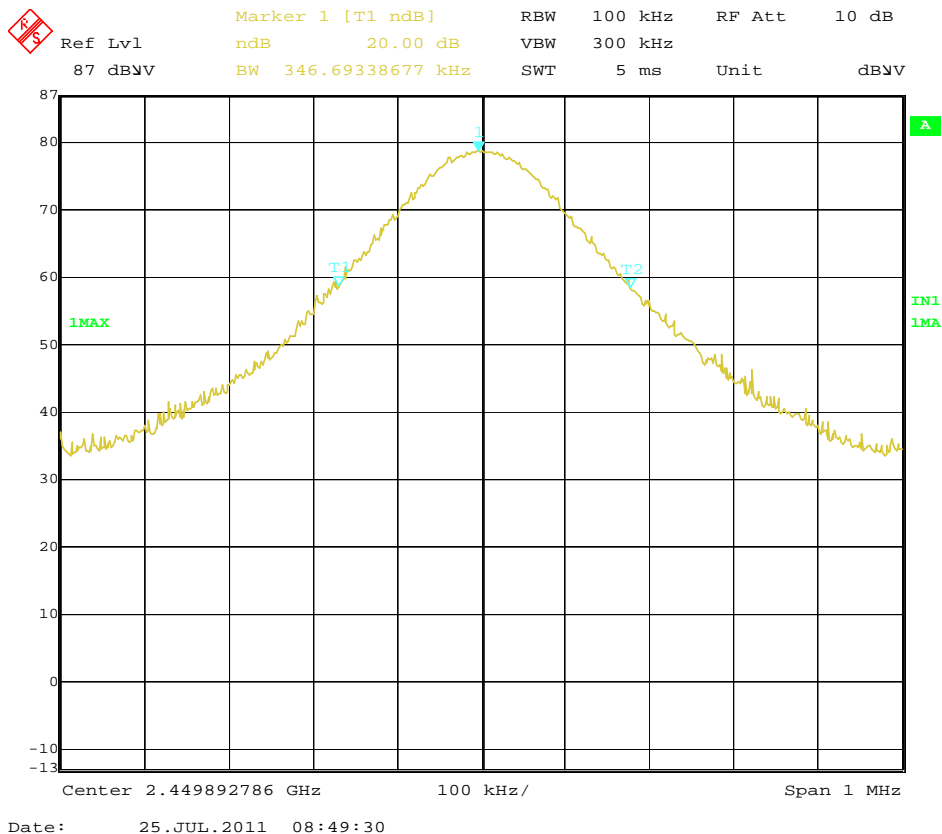

5. Test Setup Photos of the EUT



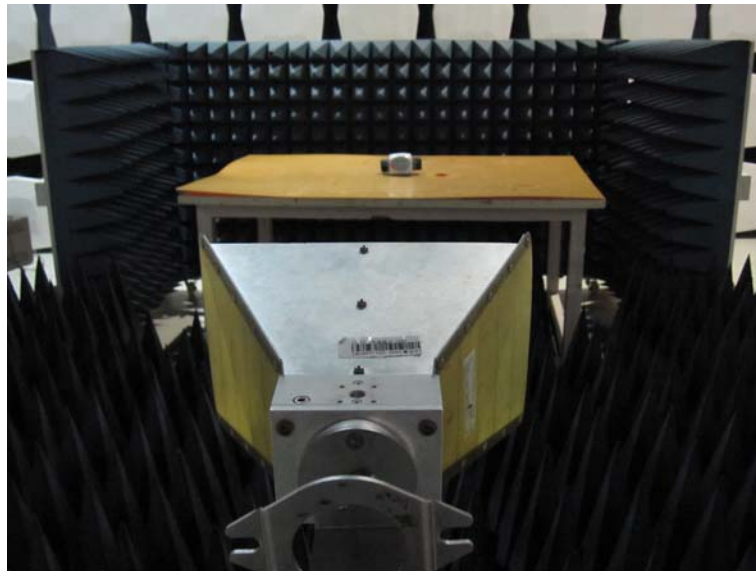

6. External and Internal Photos of the EUT

External Photos

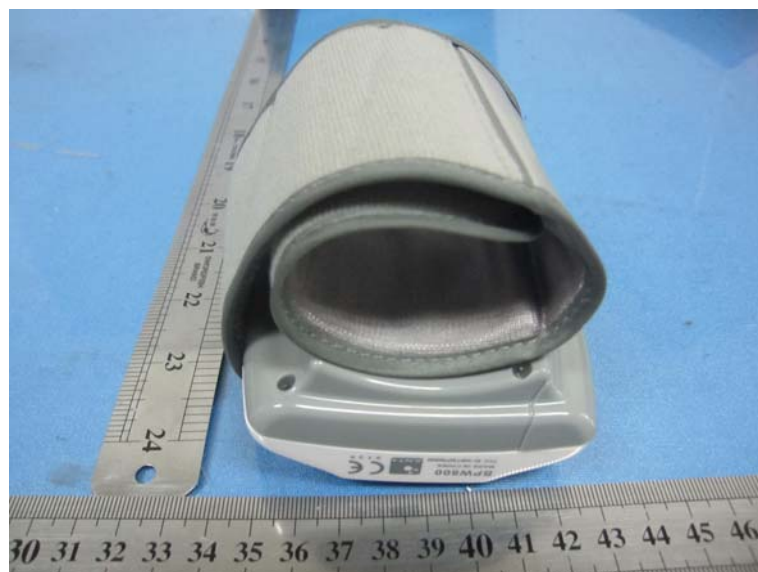

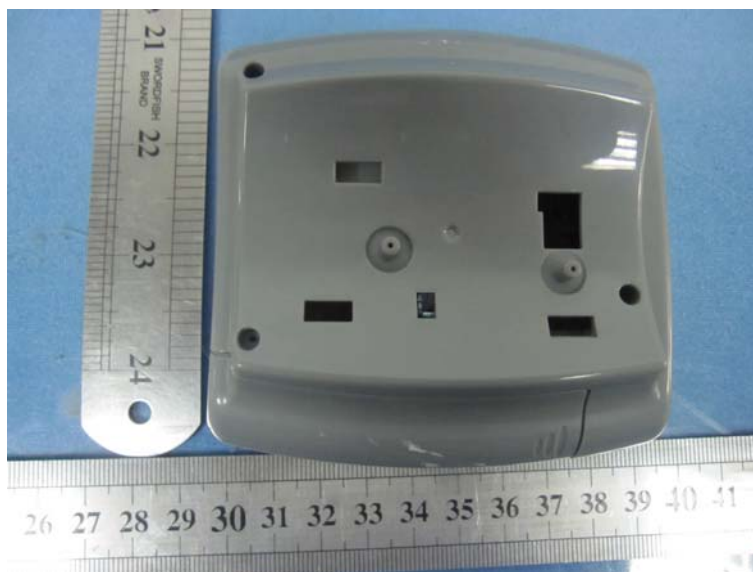

Internal Photos

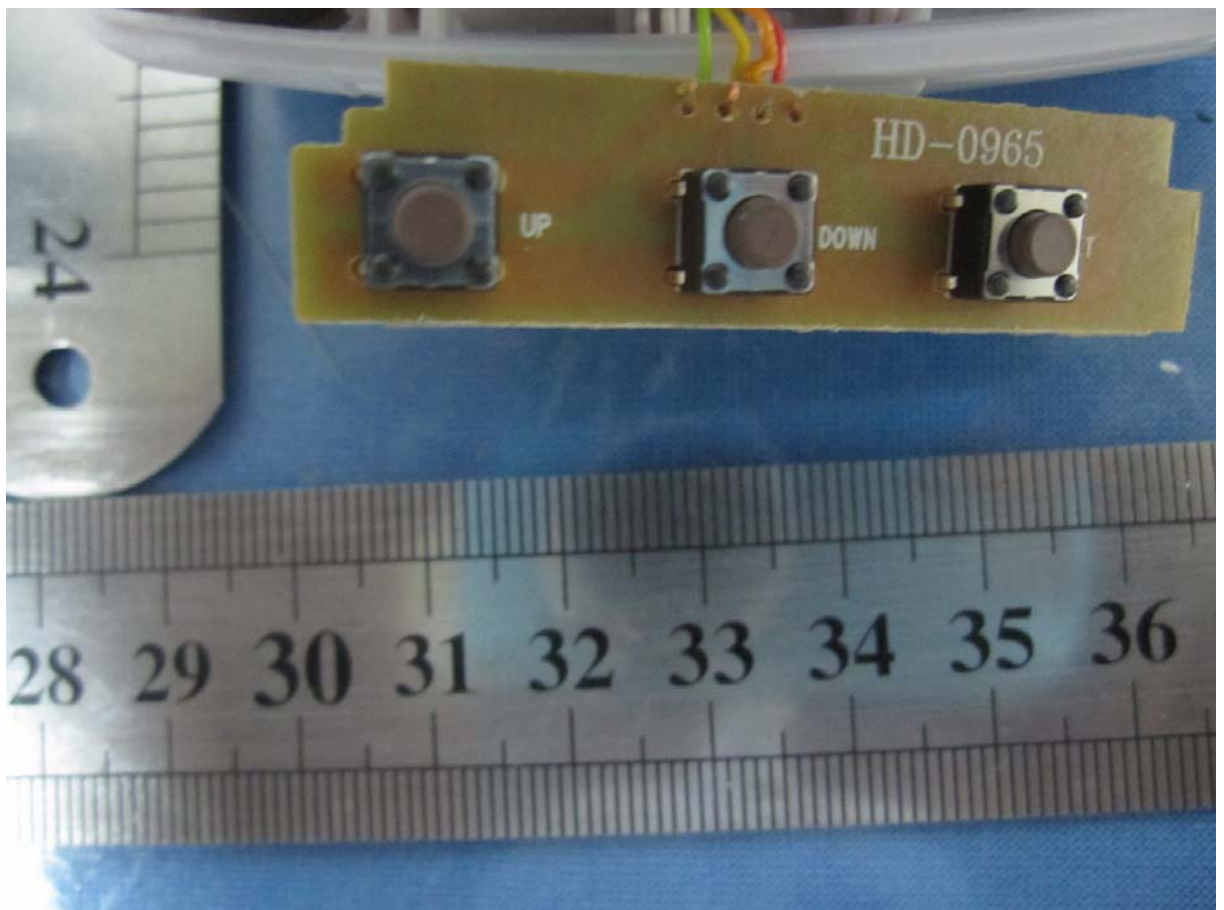
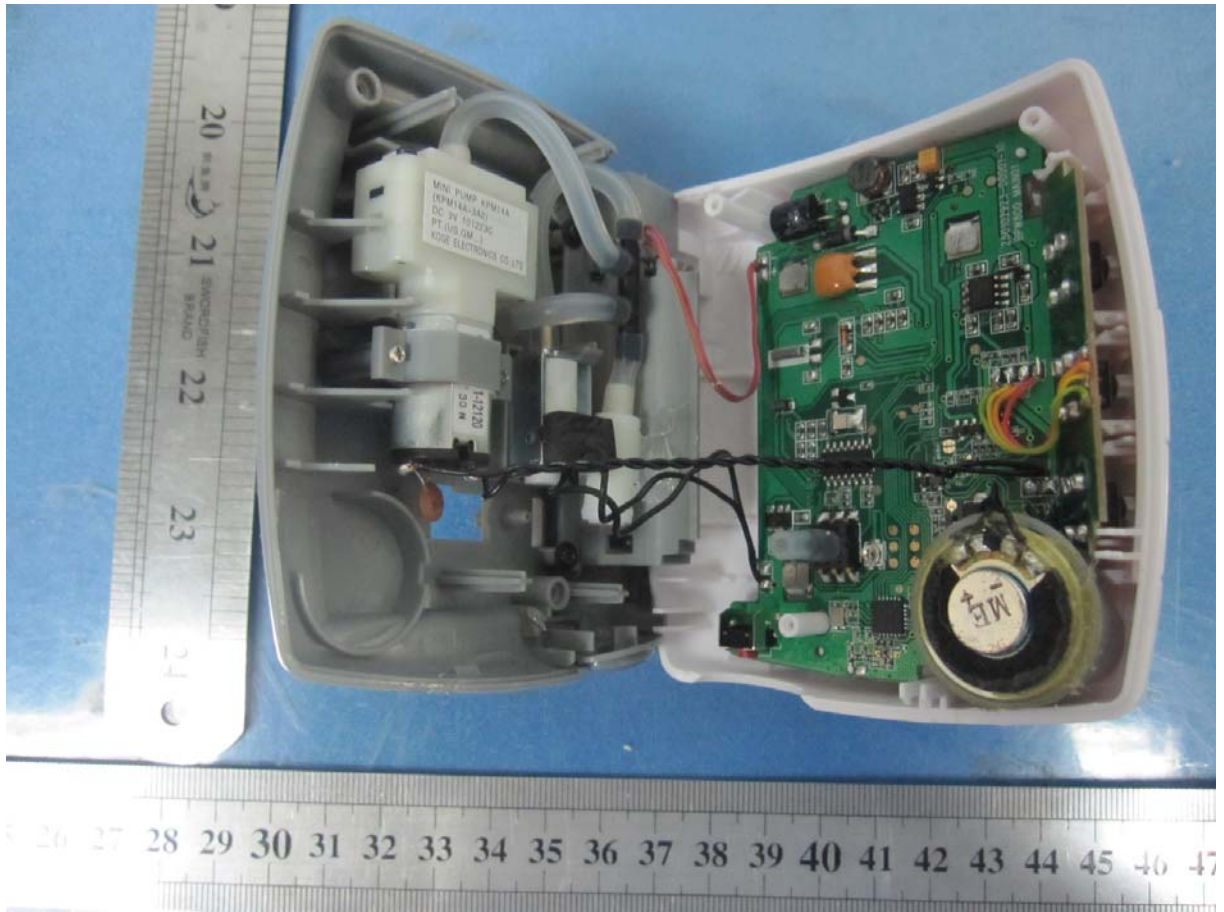

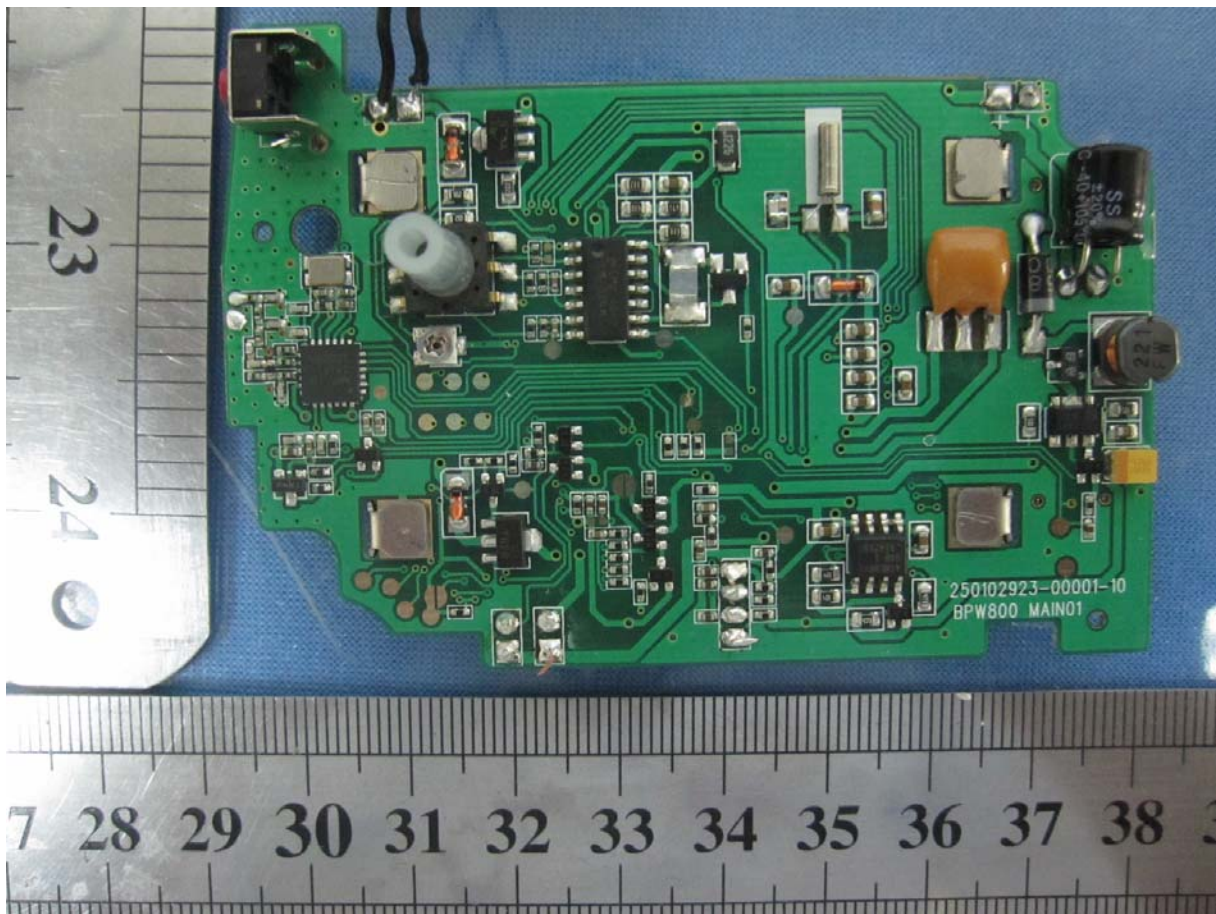
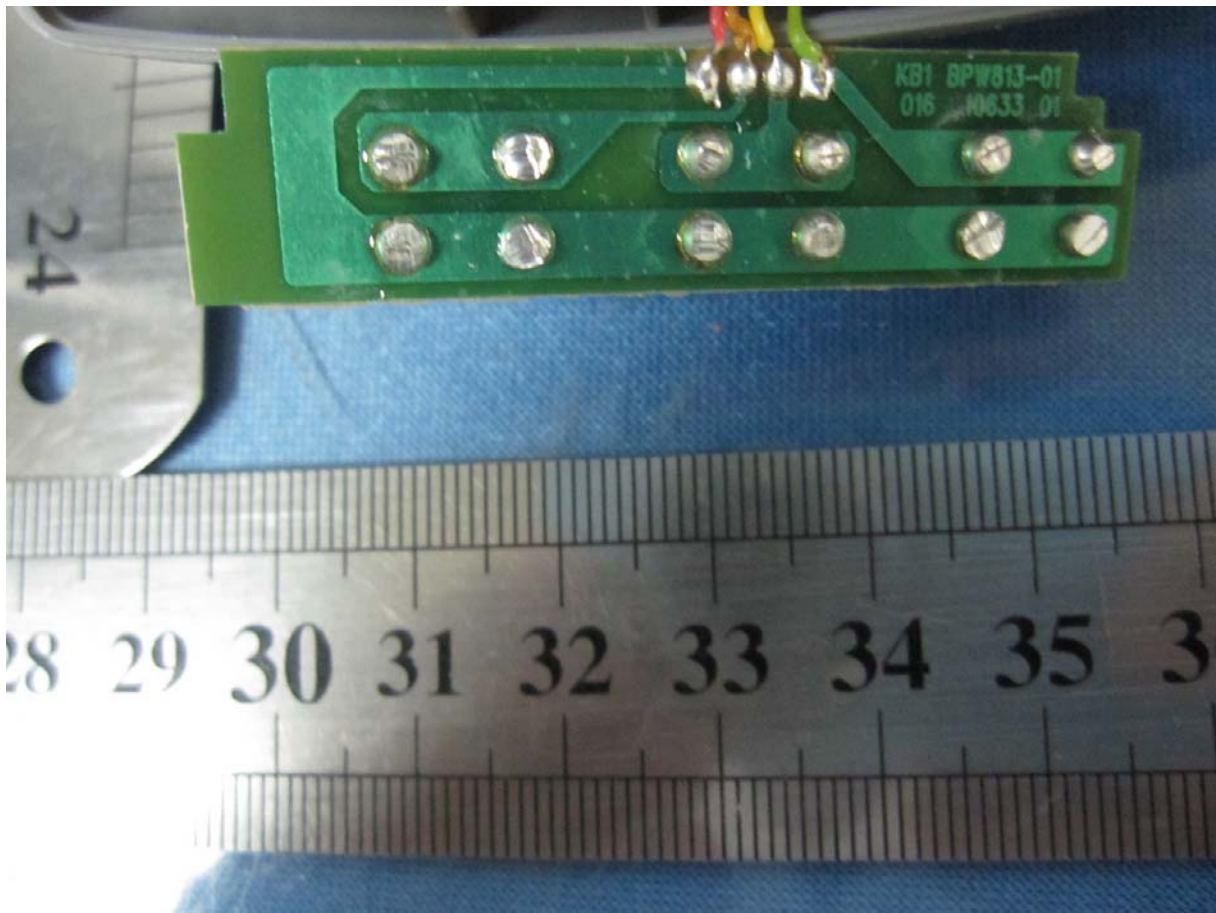

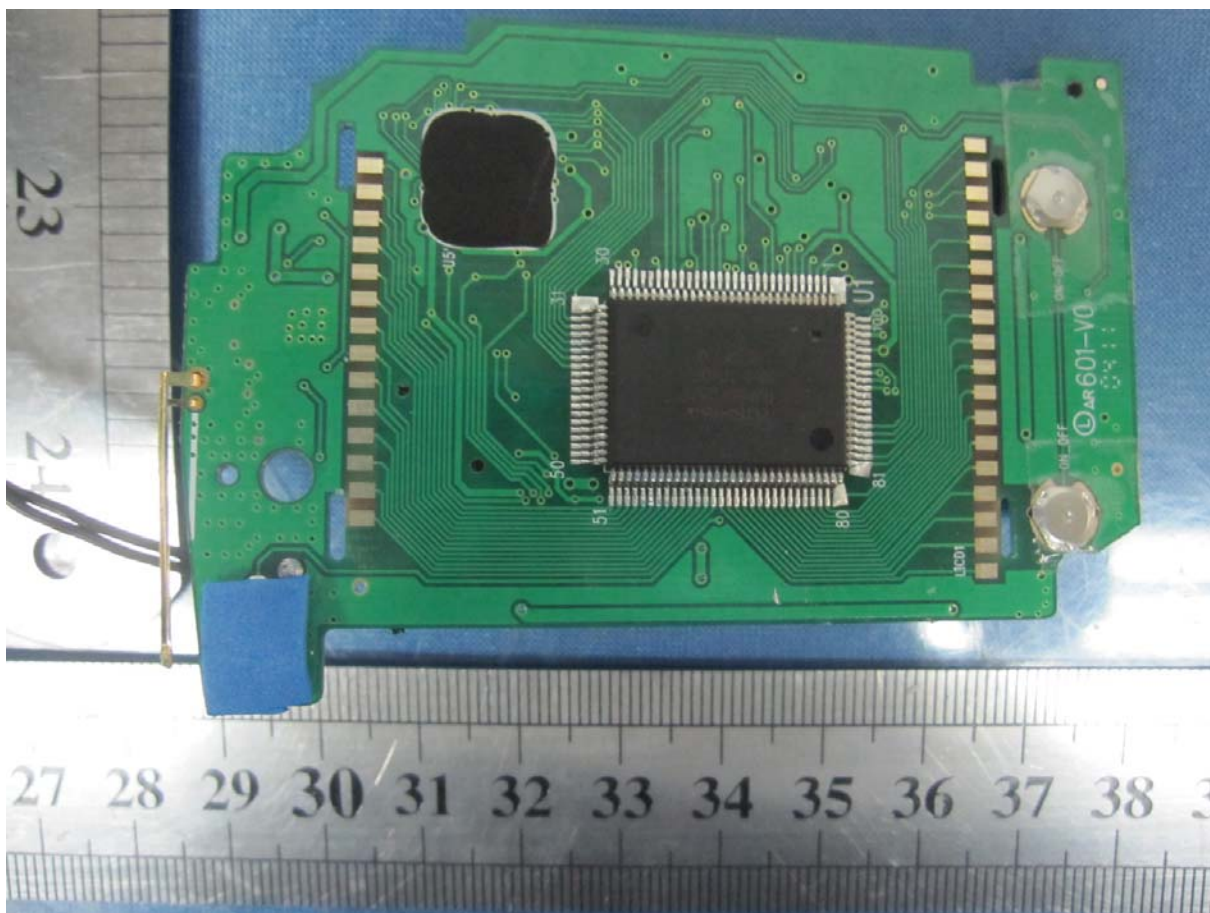
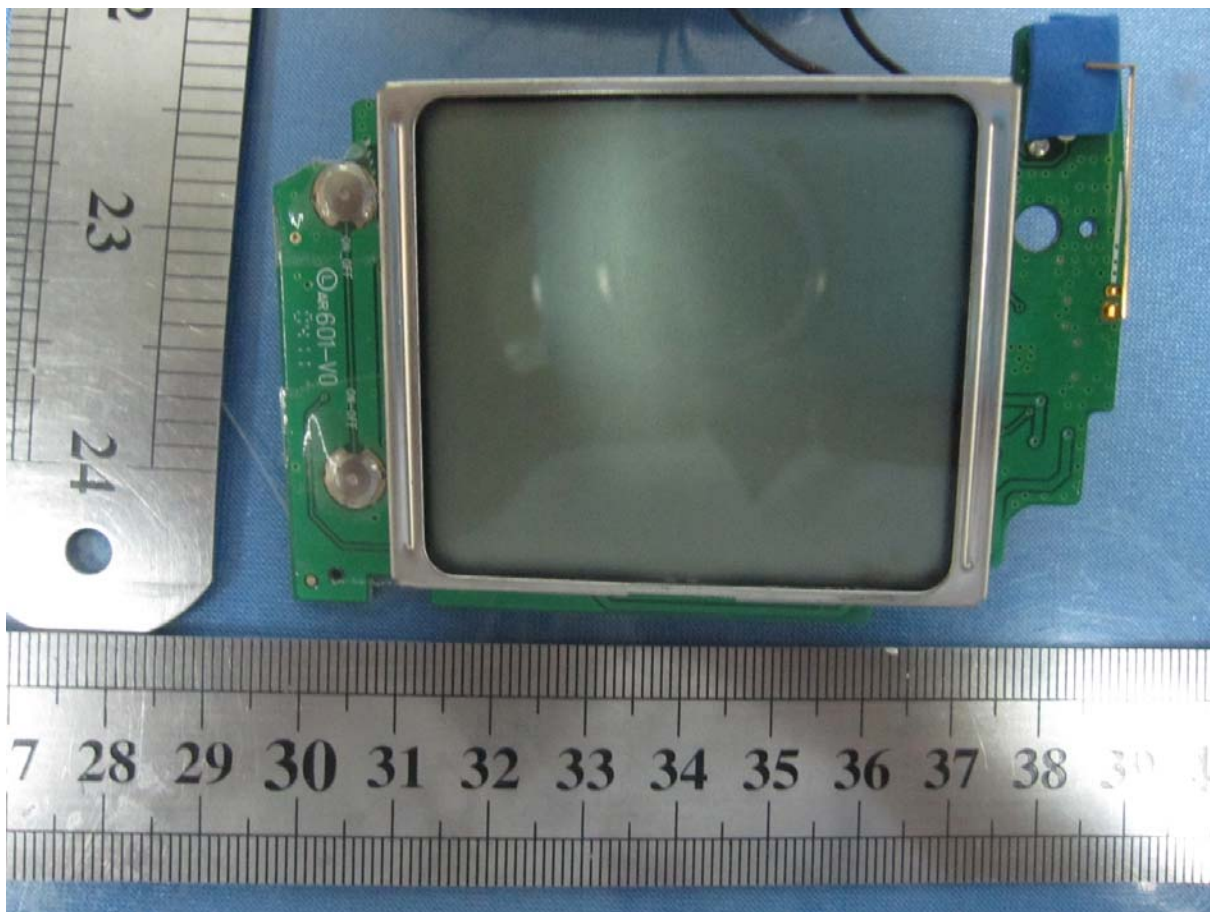

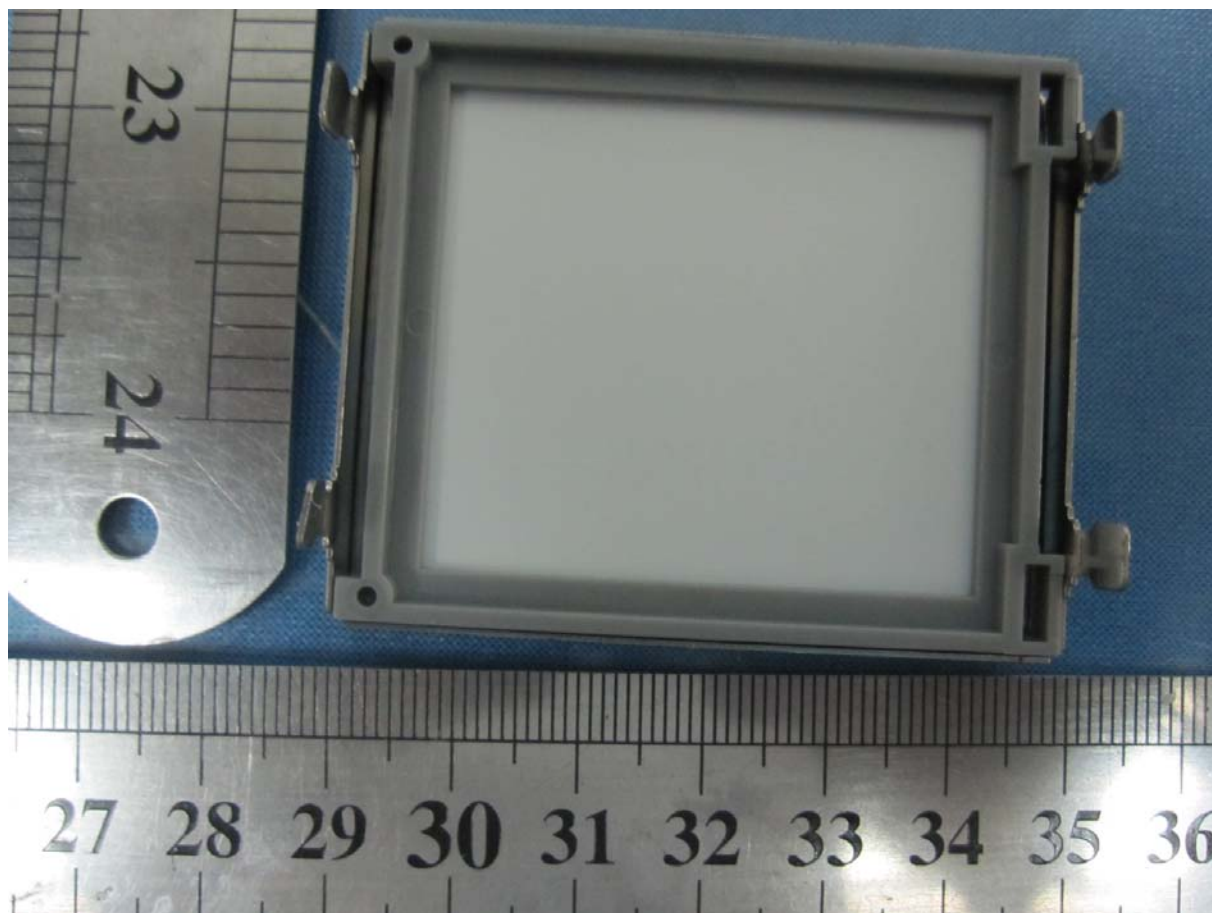
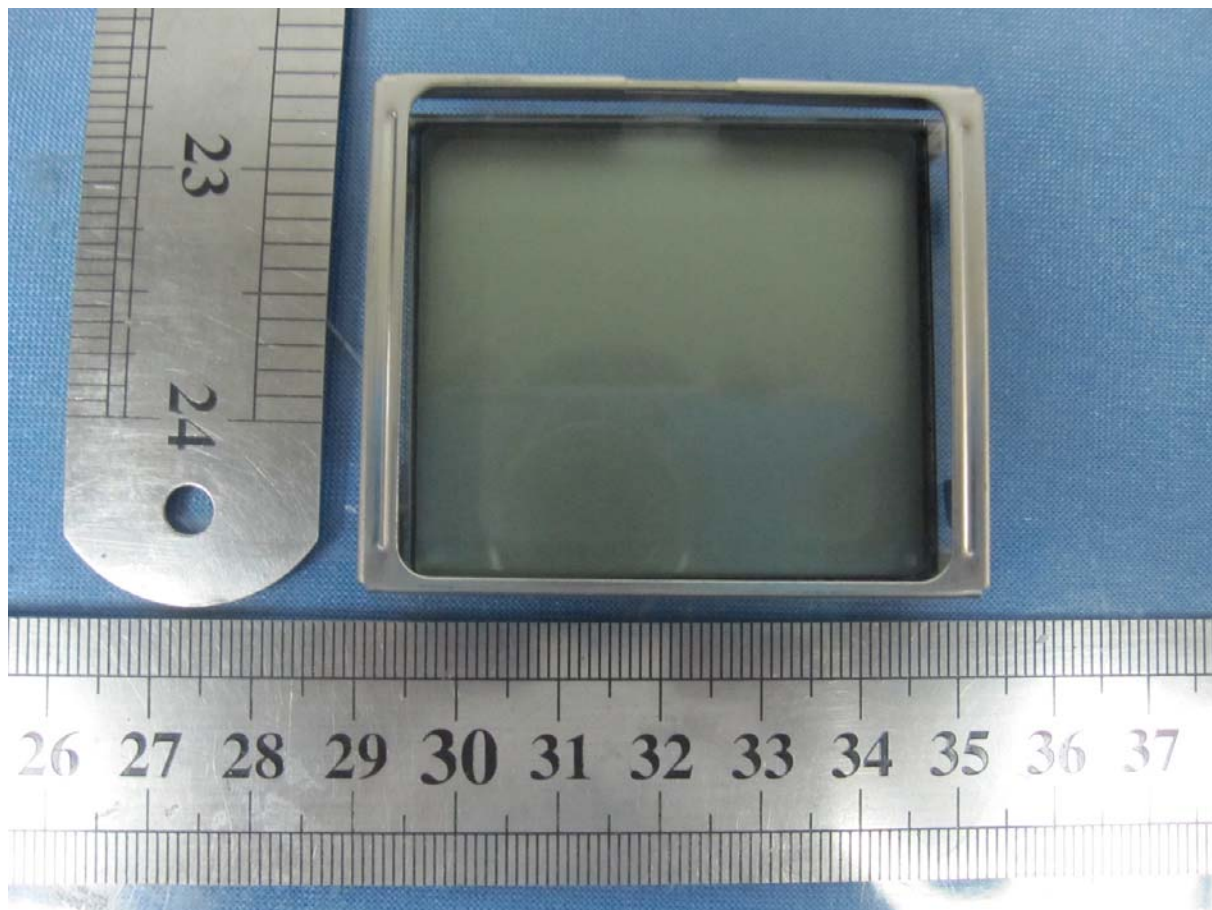

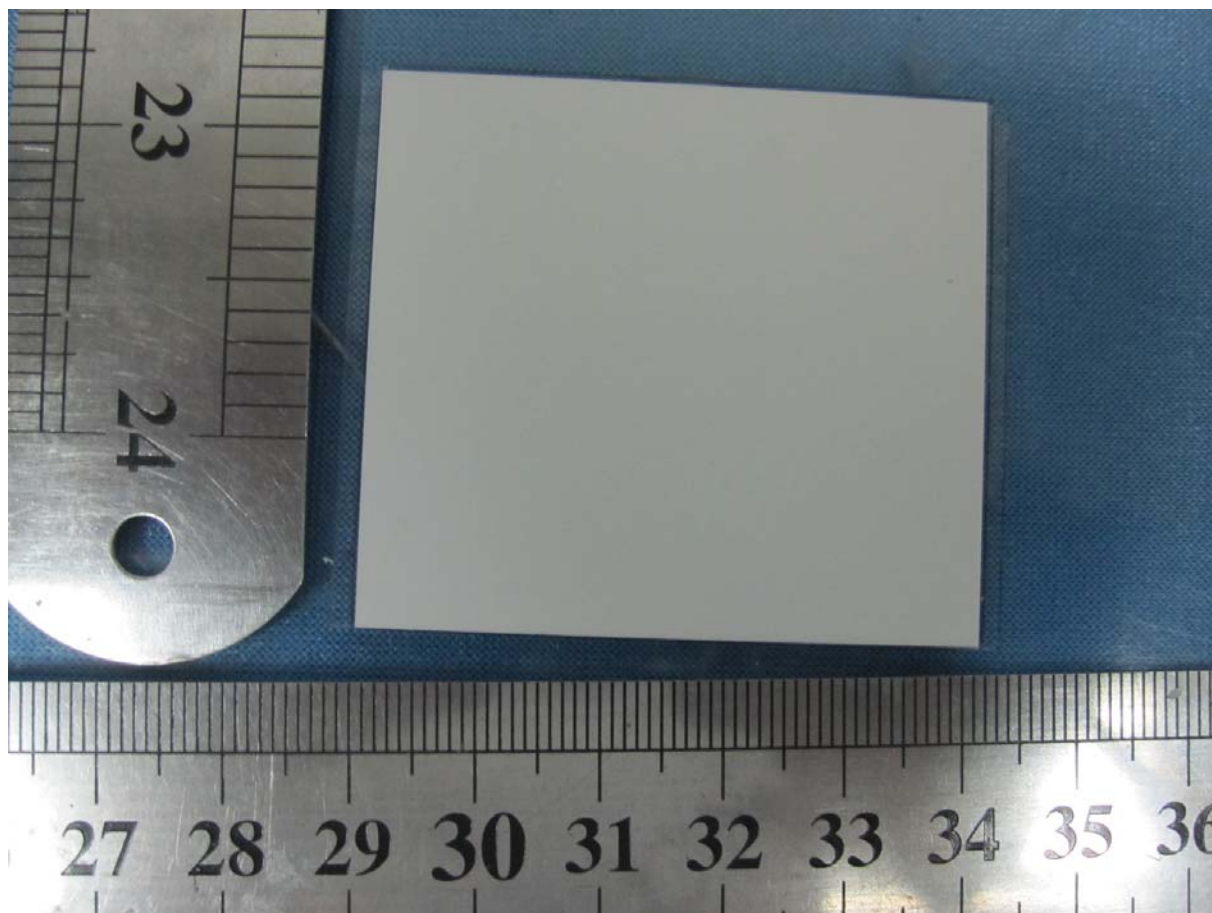
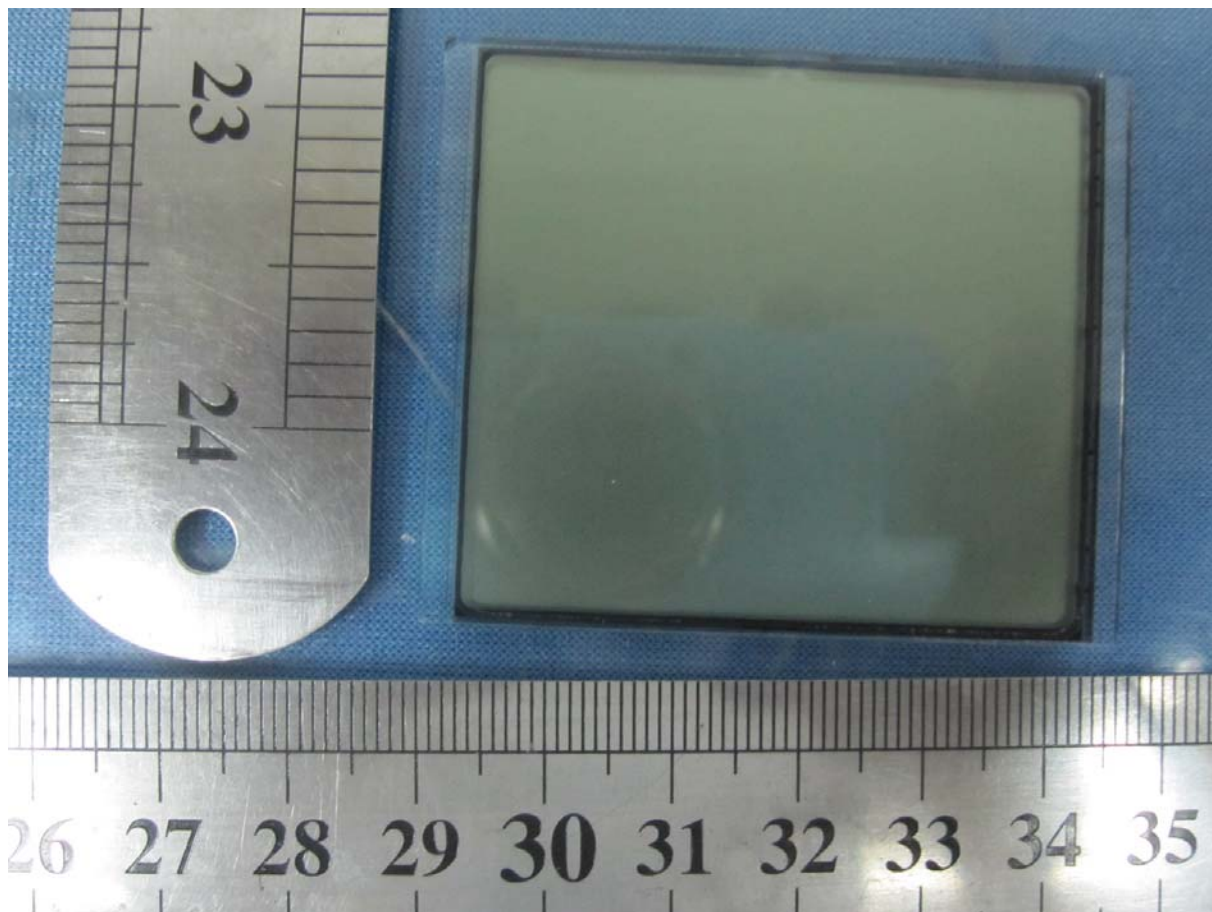

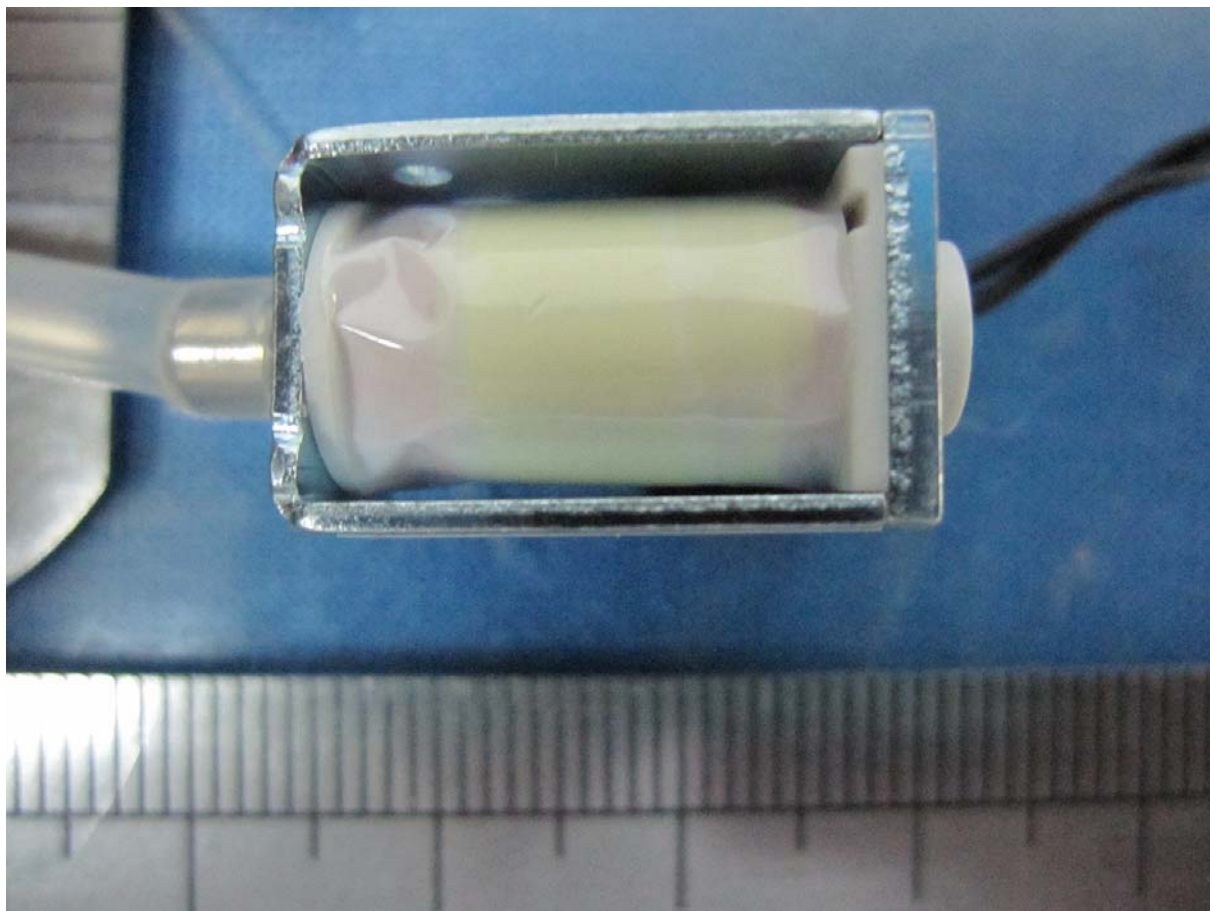

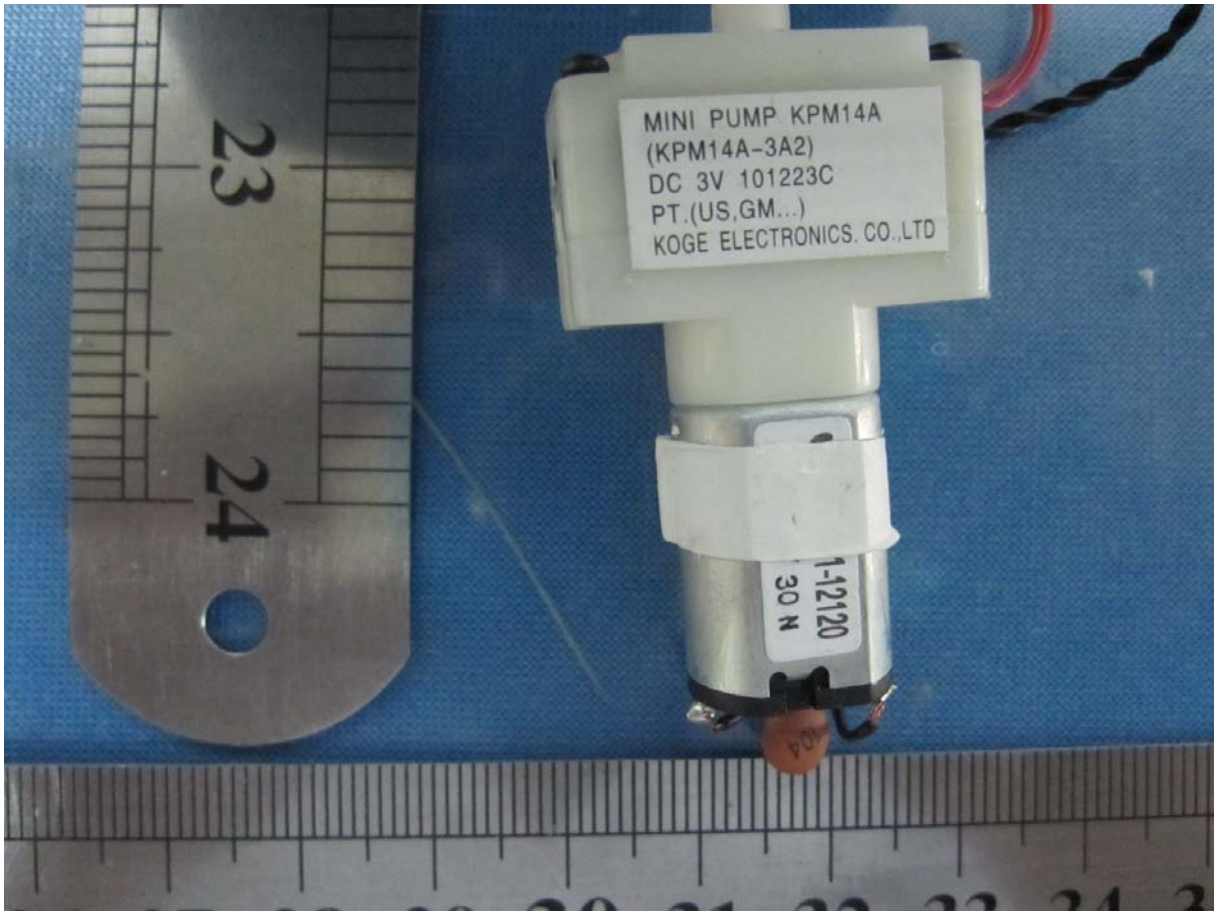

.....End of Report.....