



TEST REPORT

Report Reference No...... : **TRE14030187** R/C.....: 54147
FCC ID..... : **NMTBG201**
Applicant's name..... : **IDT Technology Limited**
Address..... : Block C, 9/F Kaiser Estate Phase 1, 41 Man Yue Street, Hung Hom, Kowloon, Hong Kong.
Manufacturer..... : IDT Technology Limited
Address..... : 29-33 Block, IDT Technology Limited, ChenTian Industrial Estate, XiXiang, BaoAn, ShenZhen
Test item description : **SmartChip**
Trade Mark : /
Model/Type reference..... : BG201
List Model : /
Standard : **FCC CFR Title 47 Part 15 Subpart C Section 15.247**
Date of receipt of test sample..... : Mar 26, 2014
Date of testing..... : Mar 27, 2014- Apr 30, 2014
Date of issue..... : May 5, 2014
Result..... : **PASS**

Compiled by
 (position+printed name+signature)..: File administrators Jerome Luo

Jerome Luo

Supervised by
 (position+printed name+signature)..: Project Engineer Yuchao Wang

yuchao.wang

Approved by
 (position+printed name+signature)..: RF Manager Hans Hu

Hans Hu

Testing Laboratory Name : **Shenzhen Huatongwei International Inspection Co., Ltd**
Address..... : Keji Nan No.12 Road, Hi-tech Park, Shenzhen, China

Shenzhen Huatongwei International Inspection Co., Ltd. All rights reserved.

This publication may be reproduced in whole or in part for non-commercial purposes as long as the Shenzhen Huatongwei International Inspection Co., Ltd is acknowledged as copyright owner and source of the material. Shenzhen Huatongwei International Inspection Co., Ltd takes no responsibility for and will not assume liability for damages resulting from the reader's interpretation of the reproduced material due to its placement and context.

Contents

1.	<u>TEST STANDARDS AND TEST DESCRIPTION</u>	3
1.1.	Test Standards	3
1.2.	Test Description	3
2.	<u>SUMMARY</u>	4
2.1.	Client Information	4
2.2.	Product Description	4
2.3.	EUT operation mode	5
2.4.	EUT configuration	5
2.5.	Modifications	5
3.	<u>TEST ENVIRONMENT</u>	6
3.1.	Address of the test laboratory	6
3.2.	Test Facility	6
3.3.	Environmental conditions	7
3.4.	Statement of the measurement uncertainty	7
3.5.	Equipments Used during the Test	8
4.	<u>TEST CONDITIONS AND RESULTS</u>	9
4.1.	Antenna requirement	9
4.2.	Conducted Peak Output Power	10
4.3.	Power Spectral Density	12
4.4.	6dB bandwidth	14
4.5.	Band Edge	16
4.6.	Spurious Emission (conducted)	21
4.7.	Spurious Emission (radiated)	25
5.	<u>TEST SETUP PHOTOS OF THE EUT</u>	30
6.	<u>EXTERNAL AND INTERNAL PHOTOS OF THE EUT</u>	31

1. TEST STANDARDS AND TEST DESCRIPTION

1.1. Test Standards

The tests were performed according to following standards:

[FCC Rules Part 15.247](#): Frequency Hopping, Direct Spread Spectrum and Hybrid Systems that are in operation within the bands of 902-928 MHz, 2400-2483.5 MHz, and 5725-5850 MHz.

[ANSI C63.10](#): American National Standard for Testing Unlicensed Wireless Devices

[KDB558074 D01 V03](#): Guidance for Performing Compliance Measurements on Digital Transmission Systems (DTS) Operating Under §15.247

1.2. Test Description

Test Item	Section in CFR 47	Result
Antenna requirement	15.203/15.247 (c)	Pass
Line Conducted Emission (AC Main)	15.207	NA
Conducted Peak Output Power	15.247 (b)(3)	Pass
Power Spectral Density	15.247 (e)	Pass
6dB Bandwidth	15.247 (a)(2)	Pass
Band Edge	15.247(d)	Pass
Spurious Emission	15.205/15.209	Pass

Remark:

1. *The measurement uncertainty is not included in the test result.*
2. *NA: Not Apply, because the EUT is a battery type product.*

2. SUMMARY

2.1. Client Information

Applicant:	IDT Technology Limited
Address:	Block C, 9/F Kaiser Estate Phase 1, 41 Man Yue Street, Hung Hom, Kowloon, Hong Kong.
Manufacturer:	IDT Technology Limited
Address:	29-33 Block, IDT Technology Limited, ChenTian Industrial Estate, XiXiang, BaoAn, ShenZhen

2.2. Product Description

Name of EUT:	SmartChip
Trade Mark:	/
Model/Type reference:	BG201
List Model:	/
Power supply:	DC 3.0V (CR2032 Size)
Adapter information:	/
Bluetooth	
Version:	Supported BT4.0
Modulation:	GFSK
Operation frequency:	2402MHz~2480MHz
Channel number:	40
Channel separation:	2MHz
Antenna type:	Internal Antenna
Antenna gain:	0.5 dBi

Operation Frequency List:

Channel	Frequency (MHz)
1	2402
2	2404
:	:
19	2438
20	2440
21	2442
:	:
39	2478
40	2480

Note:

In section 15.31(m), regards to the operating frequency range over 10 MHz, the Lowest frequency, the middle frequency, and the highest frequency of channel were selected to perform the test, please see the above gray bottom.

2.3. EUT operation mode

The EUT has been tested under typical operating condition. The Applicant provides software to control the EUT for staying in continuous transmitting and receiving mode for testing.

2.4. EUT configuration

The following peripheral devices and interface cables were connected during the measurement:

● - supplied by the manufacturer

○ - supplied by the lab

<input type="radio"/>	Power Cable	Length (m) :	/
		Shield :	/
		Detachable :	/
<input type="radio"/>	Multimeter	Manufacturer :	/
		Model No. :	/

2.5. Modifications

No modifications were implemented to meet testing criteria.

3. TEST ENVIRONMENT

3.1. Address of the test laboratory

Test Laboratory: Shenzhen Huatongwei International Inspection Co., Ltd
Address: Keji Nan No.12 Road, Hi-tech Park, Shenzhen, China
Phone: 86-755-26715686 Fax: 86-755-26748089

3.2. Test Facility

The test facility is recognized, certified, or accredited by the following organizations:

CNAS-Lab Code: L1225

Shenzhen Huatongwei International Inspection Co., Ltd. has been assessed and proved to be in compliance with CNAS-CL01 Accreditation Criteria for Testing and Calibration Laboratories (identical to ISO/IEC 17025: 2005 General Requirements) for the Competence of Testing and Calibration Laboratories, Date of Registration: Mar. 29, 2012. Valid time is until Feb. 28, 2015.

A2LA-Lab Cert. No. 2243.01

Shenzhen Huatongwei International Inspection Co., Ltd. EMC Laboratory has been accredited by A2LA for technical competence in the field of electrical testing, and proved to be in compliance with ISO/IEC 17025: 2005 General Requirements for the Competence of Testing and Calibration Laboratories and any additional program requirements in the identified field of testing. Valid time is until Sept. 30, 2013.

FCC-Registration No.: 662850

Shenzhen Huatongwei International Inspection Co., Ltd. EMC Laboratory has been registered and fully described in a report filed with the FCC (Federal Communications Commission). The acceptance letter from the FCC is maintained in our files. Registration 662850, Renewal date June. 01, 2012, valid time is until June. 01, 2015.

IC-Registration No.: 5377A

The 3m Alternate Test Site of Shenzhen Huatongwei International Inspection Co., Ltd. has been registered by Certification and Engineering Bureau of Industry Canada for the performance of radiated measurements with Registration No. 5377A on Jan. 25, 2011, valid time is until Jan. 24, 2014.

ACA

Shenzhen Huatongwei International Inspection Co., Ltd. EMC Laboratory can also perform testing for the Australian C-Tick mark as a result of our A2LA accreditation.

VCCI

The 3m Semi-anechoic chamber (12.2m×7.95m×6.7m) and Shielded Room (8m×4m×3m) of Shenzhen Huatongwei International Inspection Co., Ltd. has been registered in accordance with the Regulations for Voluntary Control Measures with Registration No.: G-292. Date of Registration: Dec. 24, 2010. Valid time is until Dec. 23, 2013.

Main Ports Conducted Interference Measurement of Shenzhen Huatongwei International Inspection Co., Ltd. has been registered in accordance with the Regulations for Voluntary Control Measures with Registration No.: C-2726. Date of Registration: Dec. 20, 2012. Valid time is until Dec. 19, 2015.

Telecommunication Ports Conducted Interference Measurement of Shenzhen Huatongwei International Inspection Co., Ltd. has been registered in accordance with the Regulations for Voluntary Control Measures with Registration No.: T-1837. Date of Registration: May 07, 2013. Valid time is until May 06, 2016.

DNV

Shenzhen Huatongwei International Inspection Co., Ltd. has been found to comply with the requirements of DNV towards subcontractor of EMC and safety testing services in conjunction with the EMC and Low voltage Directives and in the voluntary field. The acceptance is based on a formal quality Audit and follow-ups according to relevant parts of ISO/IEC Guide 17025 (2005), in accordance with the requirements of the DNV Laboratory Quality Manual towards subcontractors. Valid time is until Aug. 24, 2016.

3.3. Environmental conditions

During the measurement the environmental conditions were within the listed ranges:

Temperature:	15~35°C
Relative Humidity:	30~60 %
Air Pressure:	950~1050mba

3.4. Statement of the measurement uncertainty

The data and results referenced in this document are true and accurate. The reader is cautioned that there may be errors within the calibration limits of the equipment and facilities. The measurement uncertainty was calculated for all measurements listed in this test report according to TR-100028-01 "Electromagnetic compatibility and Radio spectrum Matters (ERM); Uncertainties in the measurement of mobile radio equipment characteristics; Part 1" and TR-100028-02 "Electromagnetic compatibility and Radio spectrum Matters (ERM); Uncertainties in the measurement of mobile radio equipment characteristics; Part 2" and is documented in the Shenzhen Huatongwei International Inspection Co., Ltd quality system according to DIN EN ISO/IEC 17025. Furthermore, component and process variability of devices similar to that tested may result in additional deviation. The manufacturer has the sole responsibility of continued compliance of the device.

Hereafter the best measurement capability for Shenzhen Huatongwei laboratory is reported:

Test Items	Measurement Uncertainty	Notes
Transmitter power conducted	0.57 dB	(1)
Transmitter power Radiated	2.20 dB	(1)
Conducted spurious emission 9KHz-40 GHz	1.60 dB	(1)
Radiated spurious emission 9KHz-40 GHz	2.20 dB	(1)
Conducted Emission 9KHz-30MHz	3.39 dB	(1)
Radiated Emission 30~1000MHz	4.24 dB	(1)
Radiated Emission 1~18GHz	5.16 dB	(1)
Radiated Emission 18-40GHz	5.54 dB	(1)
Occupied Bandwidth	-----	(1)

(1) This uncertainty represents an expanded uncertainty expressed at approximately the 95% confidence level using a coverage factor of $k=1.96$.

3.5. Equipments Used during the Test

AC Power Conducted Emission					
Item	Test Equipment	Manufacturer	Model No.	Serial No.	Cal Due
1	Artificial Mains	Rohde&Schwarz	ESH2-Z5	100028	2014/10/25
2	EMI Test Receiver	Rohde&Schwarz	ESCI3	100038	2014/10/25
3	Pulse Limiter	Rohde&Schwarz	ESHSZ2	100044	2014/10/25
4	EMI Test Software	Rohde&Schwarz	ES-K1 V1.71	N/A	N/A

Radiated Emission					
Item	Test Equipment	Manufacturer	Model No.	Serial No.	Cal Due
1	Ultra-Broadband Antenna	ShwarzBeck	VULB9163	538	2014/10/25
2	EMI TEST RECEIVER	Rohde&Schwarz	ESI 26	100009	2014/10/25
3	EMI TEST Software	Audix	E3	N/A	N/A
4	TURNTABLE	ETS	2088	2149	N/A
5	ANTENNA MAST	ETS	2075	2346	N/A
6	EMI TEST Software	Rohde&Schwarz	ESK1	N/A	N/A
7	HORN ANTENNA	ShwarzBeck	9120D	1011	2014/10/25
8	Amplifer	Sonoma	310N	E009-13	2014/10/25
9	JS amplifer	Rohde&Schwarz	JS4-00101800-28-5A	F201504	2014/10/25
10	High pass filter	Compliance Direction systems	BSU-6	34202	2014/10/25
11	HORN ANTENNA	ShwarzBeck	9120D	1012	2014/10/25
12	Amplifer	Compliance Direction systems	PAP1-4060	120	2014/10/25
13	Loop Antenna	Rohde&Schwarz	HFH2-Z2	100020	2014/10/25
14	TURNTABLE	MATURO	TT2.0	----	N/A
15	ANTENNA MAST	MATURO	TAM-4.0-P	----	N/A
16	Horn Antenna	SCHWARZBECK	BBHA9170	25841	2014/10/25
17	ULTRA-BROADBAND ANTENNA	Rohde&Schwarz	HL562	100015	2014/10/25

Maximum Peak Output Power / Power Spectral Density / 6dB Bandwidth / Band Edge Compliance of RF Emission / Spurious RF Conducted Emission					
Item	Test Equipment	Manufacturer	Model No.	Serial No.	Cal Due
1	Spectrum Analyzer	Rohde&Schwarz	FSP	1164.4391.40	2014/10/25

The Cal.Interval was one year

4. TEST CONDITIONS AND RESULTS

4.1. Antenna requirement

Requirement

FCC CFR Title 47 Part 15 Subpart C Section 15.203:

An intentional radiator shall be designed to ensure that no antenna other than that furnished by the responsible party shall be used with the device. The use of a permanently attached antenna or of an antenna that uses a unique coupling to the intentional radiator, the manufacturer may design the unit so that a broken antenna can be replaced by the user, but the use of a standard antenna jack or electrical connector is prohibited.

FCC CFR Title 47 Part 15 Subpart C Section 15.247(c) (1)(i):

(i) Systems operating in the 2400-2483.5 MHz band that is used exclusively for fixed. Point-to-point operations may employ transmitting antennas with directional gain greater than 6dBi provided the maximum conducted output power of the intentional radiator is reduced by 1 dB for every 3 dB that the directional gain of the antenna exceeds 6dBi.

Test Result:

The antenna is integral antenna, the best case gain of the antenna is 0.50dBi

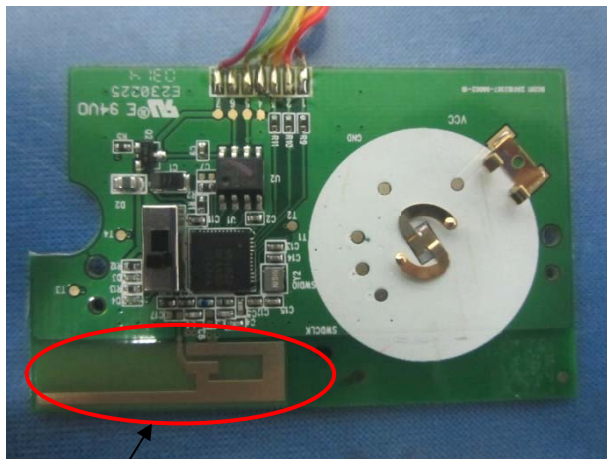

RF Antenna

4.2. Conducted Peak Output Power

LIMIT

FCC CFR Title 47 Part 15 Subpart C Section 15.247 (b)(3): **30dBm**

TEST CONFIGURATION



TEST PROCEDURE

1. The EUT was directly connected to the spectrum analyzer and antenna output port as show in the block diagram as TEST CONFIGURATION shows.
2. According to KDB558074 D01 V03 Integrated band power method for this procedure may be used when the maximum available RBW of the measurement instrument is less than the DTS bandwidth.
RBW = 3 MHz, VBW =10 MHz, span =3 MHz, Detector = peak,
3. Allow trace to fully stabilize, use peak marker function to determine the peak amplitude level.

TEST RESULTS

Channel	Output power (dBm)	Limit (dBm)	Result
01	-2.47	30.00	Pass
20	-2.10		
40	-2.26		

Test plot as follows:

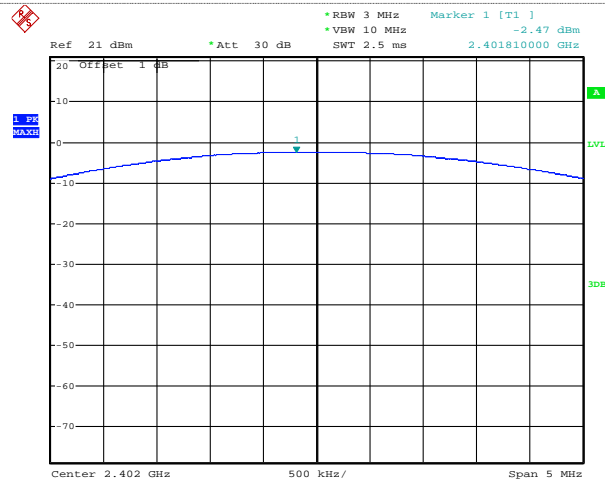

Date: 17.APR.2014 15:44:41

CH01

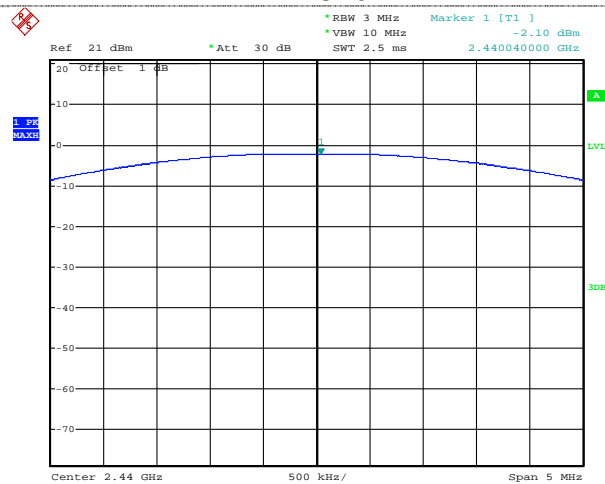

Date: 17.APR.2014 15:45:05

CH20

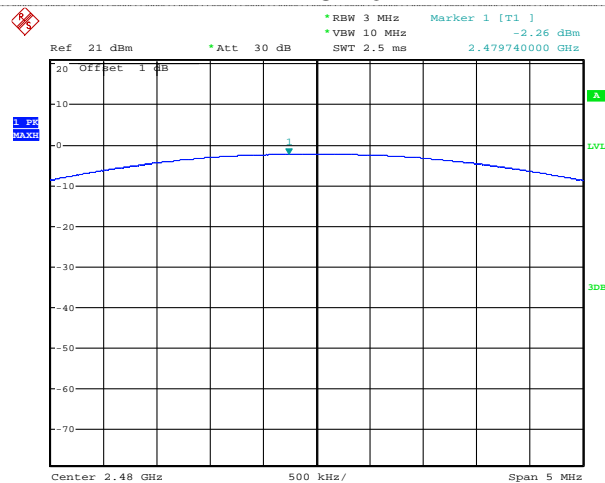

Date: 17.APR.2014 15:45:34

CH40

4.3. Power Spectral Density

LIMIT

FCC CFR Title 47 Part 15 Subpart C Section 15.247 (e): **8dBm/3KHz**

For digitally modulated systems, the power spectral density conducted from the intentional radiator to the antenna shall not be greater than 8 dBm in any 3 kHz band during any time interval of continuous transmission.

TEST CONFIGURATION



TEST PROCEDURE

1. According to KDB 558074 D01 V03 Method PKPSD (peak PSD) This procedure shall be used if maximum peak conducted output power was used to demonstrate compliance, and is optional if the maximum conducted (average) output power was used to demonstrate compliance.
2. Analyzer set:
Center frequency =Channel center frequency
RBW =3 kHz~100 kHz, VBW ≥3RBW, Detector=Peak, Span=1.5 times the bandwidth
3. Allow trace to fully stabilize, use the peak marker function to determine the maximum amplitude level within the RBW.
4. If measured value exceeds limit, reduce RBW (no less than 3 kHz) and repeat.

TEST RESULTS

Channel	Power Spectral Density (dBm/3KHz)	Limit (dBm/3KHz)	Result
01	-16.53	8.00	Pass
20	-15.87		
40	-16.35		

Test plot as follows:

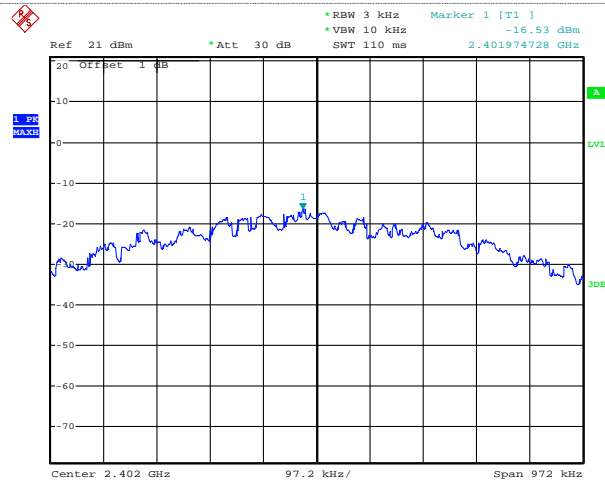

Date: 17.APR.2014 15:47:56

CH01

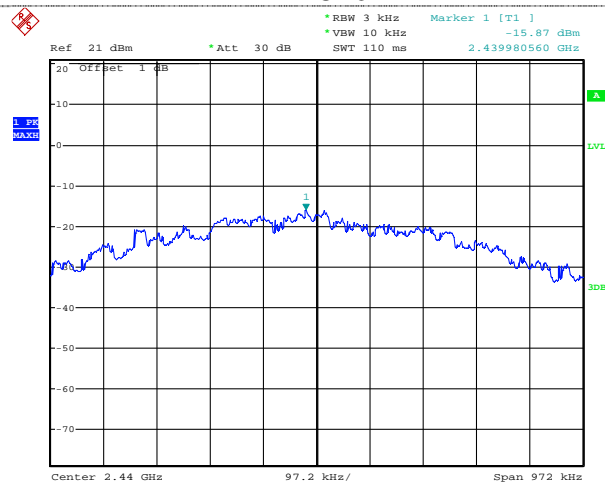

Date: 17.APR.2014 15:48:25

CH20

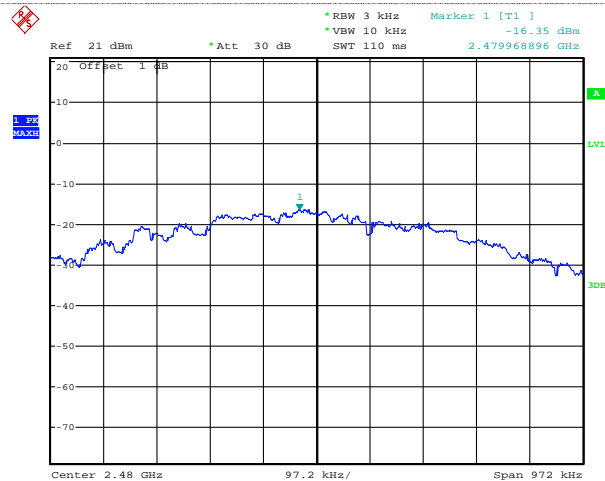

Date: 17.APR.2014 15:47:31

CH40

4.4. 6dB bandwidth

LIMIT

FCC CFR Title 47 Part 15 Subpart C Section 15.247 (a)(2): **500KHz**

For digital modulation systems, the minimum 6 dB bandwidth shall be at least 500 kHz.

TEST CONFIGURATION



TEST PROCEDURE

1. The transmitter output was connected to the spectrum analyzer through an attenuator. The bandwidth of the fundamental frequency was measured by spectrum analyzer
2. The 6dB bandwidth is defined as the total spectrum the power of which is higher than peak power minus 6dB.
3. According to KDB558074 D01 V03 for one of the following procedures may be used to determine the modulated DTS device signal bandwidth.
Center frequency =Channel center frequency
RBW =100 kHz, VBW ≥3RBW, Detector=Peak,
4. Allow the trace to stabilize.
5. Measure the maximum width of the emission that is constrained by the frequencies associated with the two outermost amplitude points (upper and lower frequencies) that are attenuated by 6 dB relative to the maximum level measured in the fundamental emission.

TEST RESULTS

Channel	6dB Bandwidth (MHz)	Limit (KHz)	Result
01	0.648	≥ 500	Pass
20	0.636		
40	0.642		

Test plot as follows:

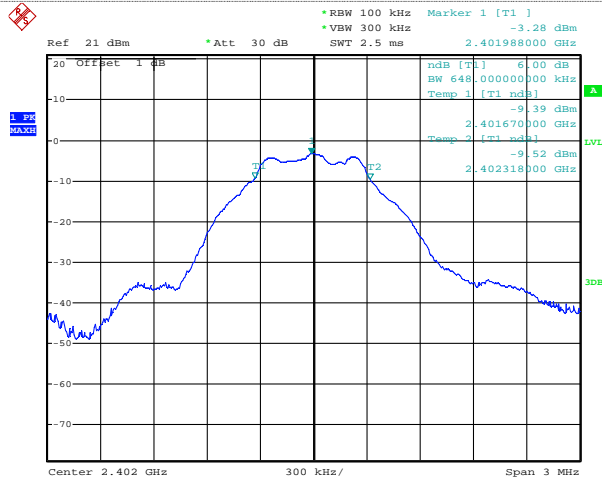

Date: 17.APR.2014 15:39:46

CH01

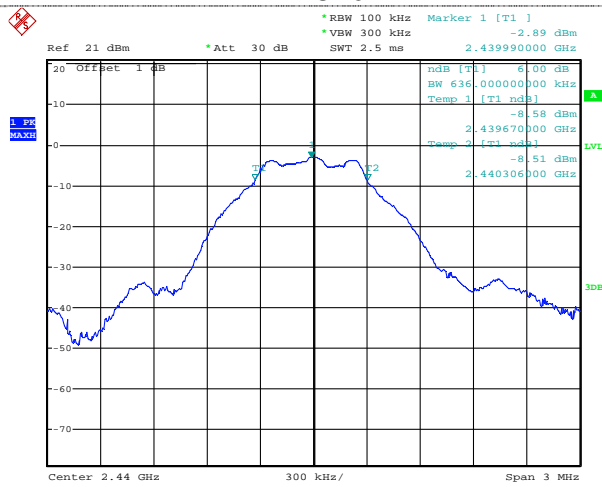

Date: 17.APR.2014 15:38:59

CH20

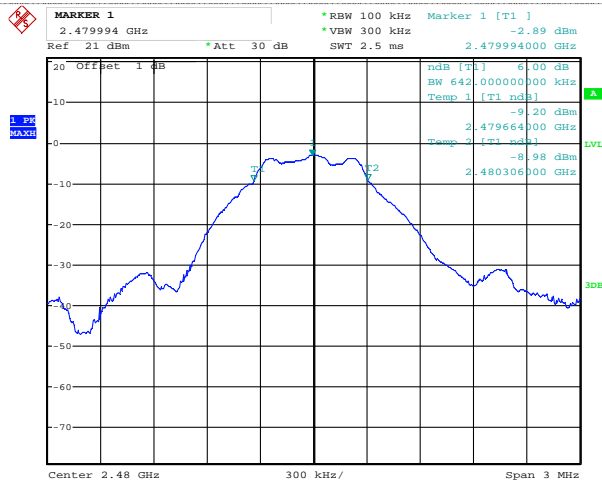

Date: 17.APR.2014 15:40:54

CH40

4.5. Band Edge

LIMIT

FCC CFR Title 47 Part 15 Subpart C Section 15.247 (d):

In any 100 kHz bandwidth outside the frequency band in which the spread spectrum or digitally modulated intentional radiator is operating, the radio frequency power that is produced by the intentional radiator shall be at least 20 dB below that in the 100 kHz bandwidth within the band that contains the highest level of the desired power, based on either an RF conducted or a radiated measurement, provided the transmitter demonstrates compliance with the peak conducted power limits. If the transmitter complies with the conducted power limits based on the use of RMS averaging over a time interval, as permitted under paragraph (b)(3) of this section, the attenuation required under this paragraph shall be 30 dB instead of 20 dB. Attenuation below the general limits specified in §15.209(a) is not required. In addition, radiated emissions which fall in the restricted bands, as defined in §15.205(a), must also comply with the radiated emission limits specified in §15.209(a) (see §15.205(c)).

TEST CONFIGURATION



TEST PROCEDURE

1. According to KDB 558074 D01 V03 for Antenna-port conducted measurement. Antenna-port conducted measurements may also be used as an alternative to radiated measurements for demonstrating compliance in the restricted frequency bands. If conducted measurements are performed, then proper impedance matching must be ensured and an additional radiated test for cabinet/case spurious emissions is required.
2. Remove the antenna from the EUT and then connect to a low loss RF cable from the antenna port to a EMI test receiver, then turn on the EUT and make it operate in transmitting mode. Then set it to Low Channel and High Channel within its operating range, and make sure the instrument is operated in its linear range.
3. Set both RBW and VBW of spectrum analyzer to 100 kHz with a convenient frequency span including 100kHz bandwidth from band edge, for Radiated emissions restricted band RBW=1MHz, VBW=3MHz for peak detector and RBW=1MHz, VBW=10Hz for average detector.
4. Measure the highest amplitude appearing on spectral display and set it as a reference level. Plot the graph with marking the highest point and edge frequency.
5. Repeat above procedures until all measured frequencies were complete.
6. Measure the conducted output power (in dBm) using the detector specified by the appropriate regulatory agency
7. Add the maximum transmit antenna gain (in dBi) to the measured output power level to determine the EIRP level
8. Add the appropriate maximum ground reflection factor to the EIRP level (6 dB for frequencies ≤ 30 MHz, 4.7 dB for frequencies between 30 MHz and 1000 MHz, inclusive and 0 dB for frequencies > 1000 MHz).
9. For devices with multiple antenna-ports, measure the power of each individual chain and sum the EIRP of all chains in linear terms (e.g., Watts, mW).
10. Convert the resultant EIRP level to an equivalent electric field strength using the following relationship:

$$E = \text{EIRP} - 20\log D + 104.8$$
 where:
 E = electric field strength in dB μ V/m,
 EIRP = equivalent isotropic radiated power in dBm
 D = specified measurement distance in meters.
11. Since the out-of-band characteristics of the EUT transmit antenna will often be unknown, the use of a conservative antenna gain value is necessary. Thus, when determining the EIRP based on the measured conducted power, the upper bound on antenna gain for a device with a single RF output shall be selected as the maximum in-band gain of the antenna across all operating bands, or 2 dBi, whichever is greater. However, for devices that operate in multiple frequency bands while using the same transmit antenna, the highest gain of the antenna within the operating band nearest in frequency to the restricted band emission being measured may be used in lieu of the overall highest gain when the emission is at a frequency that is within 20 percent of the nearest band edge frequency, but in no case shall a value less than 2 dBi be used.
12. Compare the resultant electric field strength level to the applicable regulatory limit.
13. Perform radiated spurious emission test dures until all measured frequencies were complete.

TEST RESULTS

Test level:	Peak	Test Channel:	01
-------------	------	---------------	----

Data: 149 File: D:\E3\HTW\0415-1.EM6 (149) Date: 04-16-2014

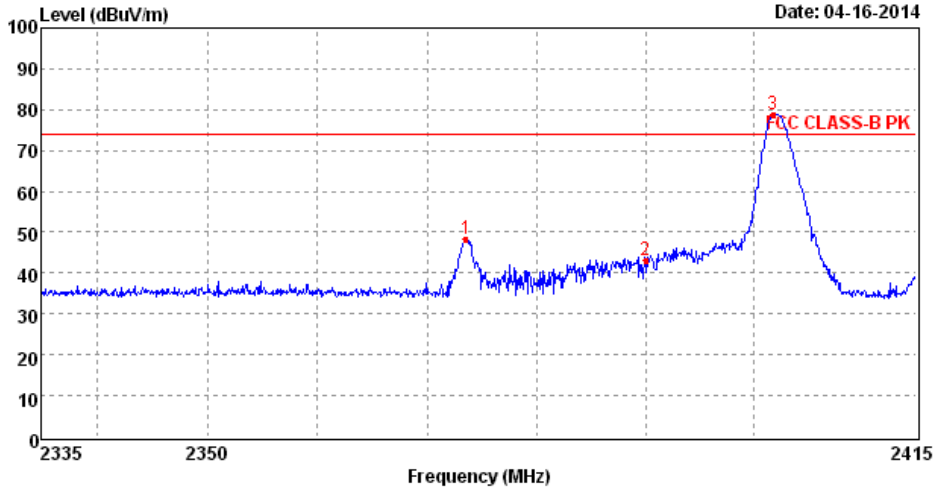

Mark	Frequency MHz	Level dBuV/m	Factor dB	Reading dBuV/m	Limit dBuV/m	Margin dB	Polarization	Det.
1	2373.54	48.50	-5.23	53.73	74.00	25.50	HORIZONTAL	Peak
2	2390.00	43.04	-5.28	48.32	74.00	30.96	HORIZONTAL	Peak
3	2401.78	78.82	-5.31	84.13	74.00	-4.82	HORIZONTAL	Peak

Test level:	Peak	Test Channel:	01
-------------	------	---------------	----

Data: 151 File: D:\E3\HTW\0415-1.EM6 (151) Date: 04-16-2014

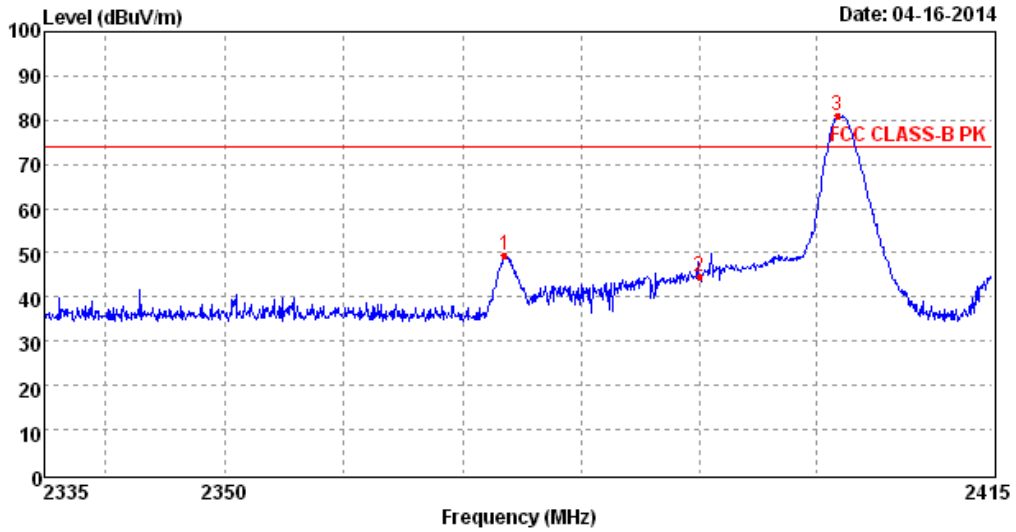

Mark	Frequency MHz	Level dBuV/m	Factor dB	Reading dBuV/m	Limit dBuV/m	Margin dB	Polarization	Det.
1	2373.54	49.29	-5.23	54.52	74.00	24.71	VERTICAL	Peak
2	2390.00	44.71	-5.28	49.99	74.00	29.29	VERTICAL	Peak
3	2401.78	80.92	-5.31	86.23	74.00	-6.92	VERTICAL	Peak

Test level:	Average	Test Channel:	01
-------------	---------	---------------	----

Data: 150 File: D:\E3\HTW\0415-1.EM6 (150)

Date: 04-16-2014

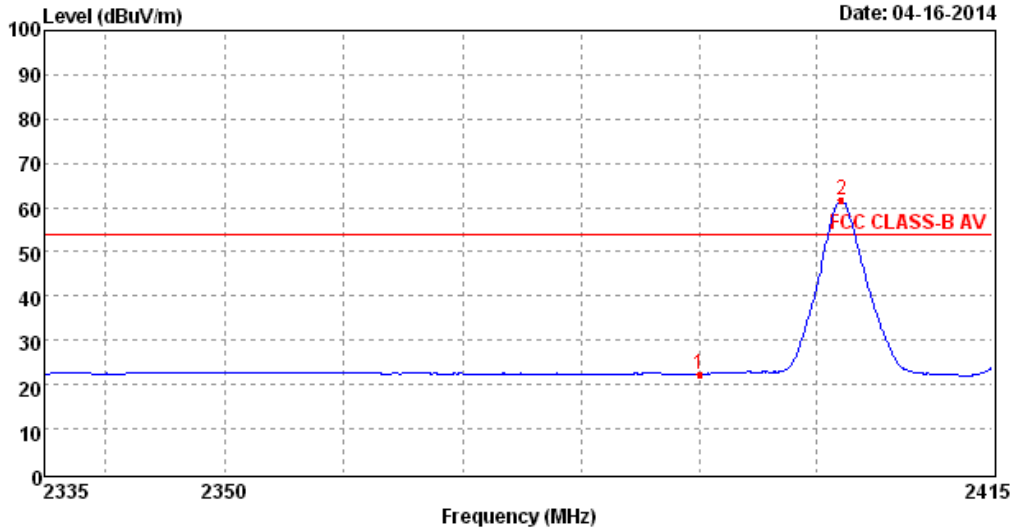

Mark	Frequency MHz	Level dBuV/m	Factor dB	Reading dBuV/m	Limit dBuV/m	Margin dB	Polarization	Det.
1	2390.00	22.41	-5.28	27.69	54.00	31.59	HORIZONTAL	Peak
2	2402.10	61.55	-5.31	66.86	54.00	-7.55	HORIZONTAL	Peak

Test level:	Average	Test Channel:	01
-------------	---------	---------------	----

Data: 152 File: D:\E3\HTW\0415-1.EM6 (152)

Date: 04-16-2014

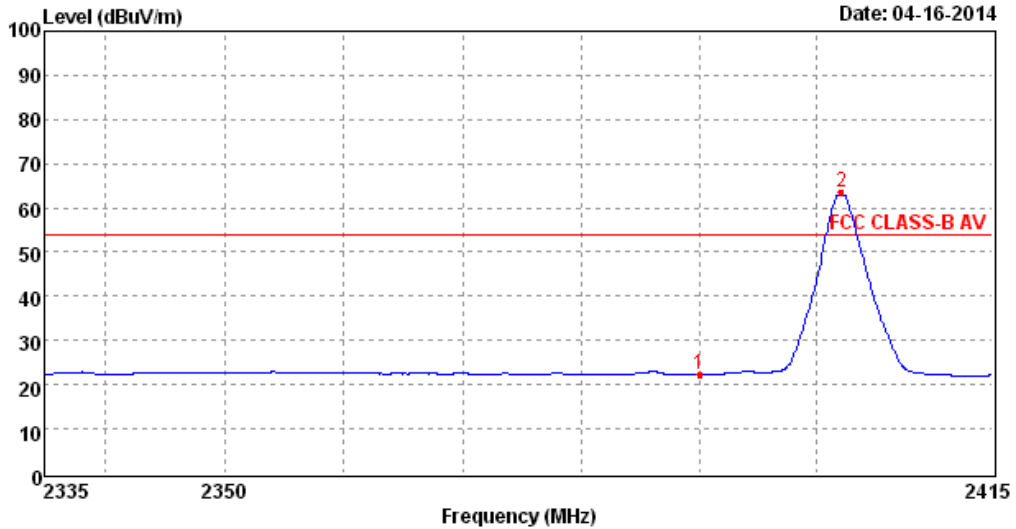

Mark	Frequency MHz	Level dBuV/m	Factor dB	Reading dBuV/m	Limit dBuV/m	Margin dB	Polarization	Det.
1	2390.00	22.32	-5.28	27.60	54.00	31.68	VERTICAL	Peak
2	2402.10	63.56	-5.31	68.87	54.00	-9.56	VERTICAL	Peak

Test level:	Peak	Test Channel:	40
-------------	------	---------------	----

Data: 156 File: D:\E3\HTW\0415-1.EM6 (156)

Date: 04-16-2014

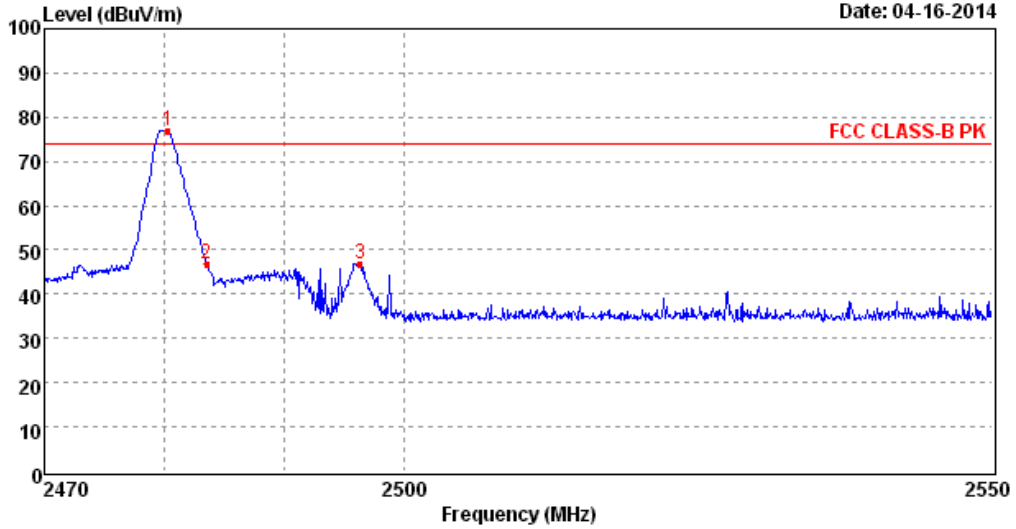

Mark	Frequency MHz	Level dBuV/m	Factor dB	Reading dBuV/m	Limit dBuV/m	Margin dB	Polarization	Det.
1	2480.26	76.96	-5.22	82.18	74.00	-2.96	HORIZONTAL	Peak
2	2483.50	46.90	-5.22	52.12	74.00	27.10	HORIZONTAL	Peak
3	2496.36	47.00	-5.20	52.20	74.00	27.00	HORIZONTAL	Peak

Test level:	Peak	Test Channel:	40
-------------	------	---------------	----

Data: 153 File: D:\E3\HTW\0415-1.EM6 (153)

Date: 04-16-2014

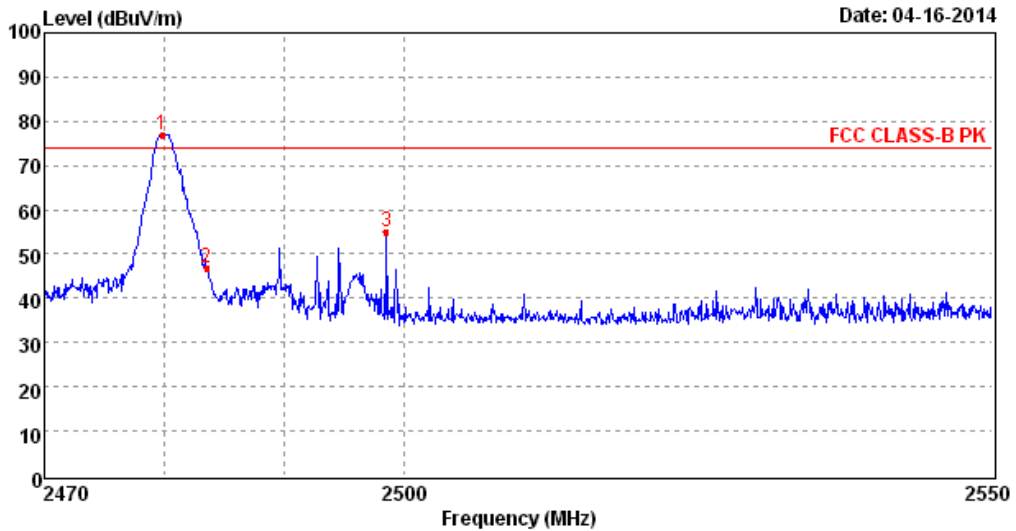

Mark	Frequency MHz	Level dBuV/m	Factor dB	Reading dBuV/m	Limit dBuV/m	Margin dB	Polarization	Det.
1	2479.78	77.05	-5.22	82.27	74.00	-3.05	VERTICAL	Peak
2	2483.50	46.87	-5.22	52.09	74.00	27.13	VERTICAL	Peak
3	2498.59	54.99	-5.20	60.19	74.00	19.01	VERTICAL	Peak

Test level:	Average	Test Channel:	40
-------------	---------	---------------	----

Data: 157 File: D:\E3\HTW\0415-1.EM6 (157)

Date: 04-16-2014

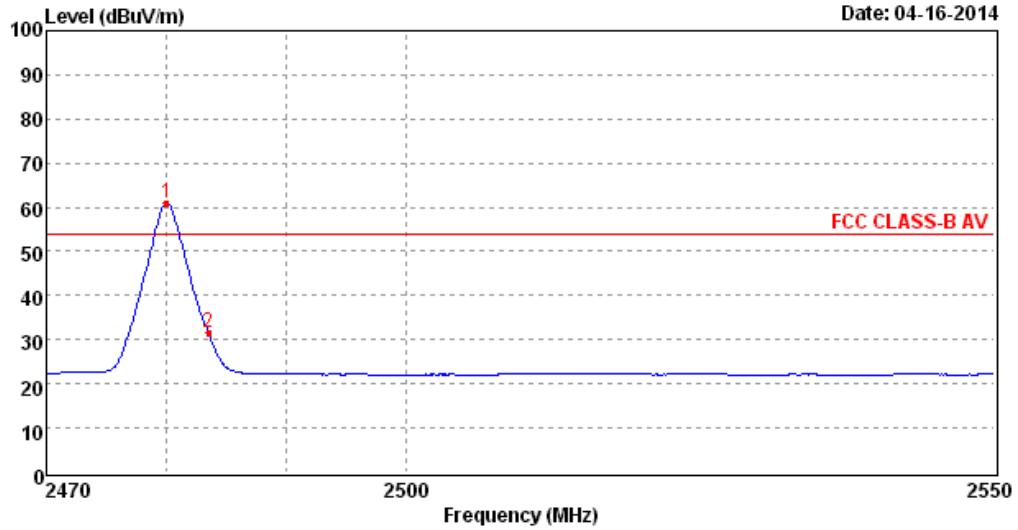

Mark	Frequency MHz	Level dBuV/m	Factor dB	Reading dBuV/m	Limit dBuV/m	Margin dB	Polarization	Det.
1	2480.02	60.85	-5.22	66.07	54.00	-6.85	HORIZONTAL	Peak
2	2483.50	31.50	-5.22	36.72	54.00	22.50	HORIZONTAL	Peak

Test level:	Average	Test Channel:	40
-------------	---------	---------------	----

Data: 154 File: D:\E3\HTW\0415-1.EM6 (154)

Date: 04-16-2014

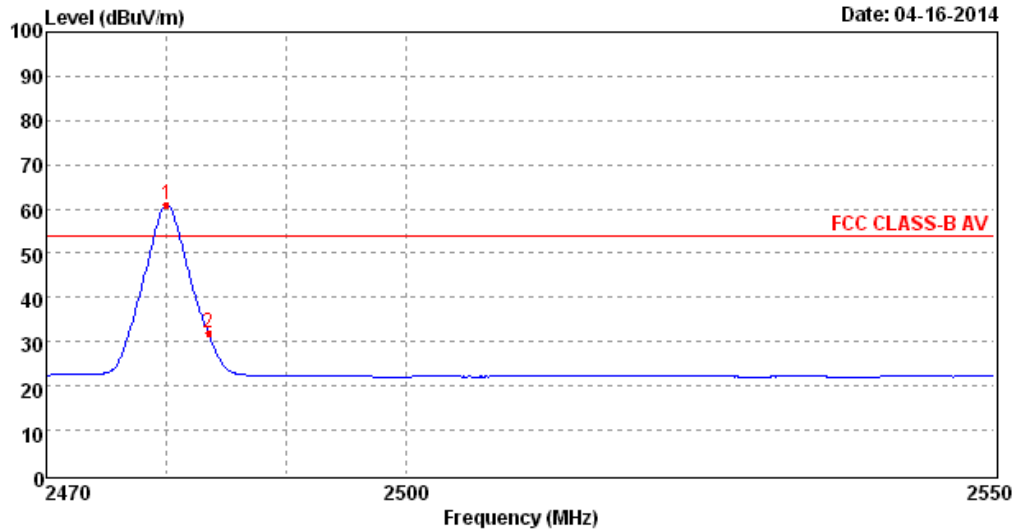

Mark	Frequency MHz	Level dBuV/m	Factor dB	Reading dBuV/m	Limit dBuV/m	Margin dB	Polarization	Det.
1	2480.02	61.08	-5.22	66.30	54.00	-7.08	VERTICAL	Peak
2	2483.50	31.82	-5.22	37.04	54.00	22.18	VERTICAL	Peak

4.6. Spurious Emission (conducted)

LIMIT

FCC CFR Title 47 Part 15 Subpart C Section 15.247 (d):

In any 100 kHz bandwidth outside the frequency band in which the spread spectrum intentional radiator is operating, the radio frequency power that is produced by the intentional radiator shall be at least 20 dB below that in the 100 kHz bandwidth within the band that contains the highest level of the desired power, based on either an RF conducted or a radiated measurement.

TEST CONFIGURATION



TEST PROCEDURE

1. The transmitter output was connected to the spectrum analyzer through an attenuator.
2. The bandwidth of the fundamental frequency was measured by spectrum analyzer with RBW=100 KHz and VBW=300KHz.
3. Below -20dB of the highest emission level in operating band.

TEST RESULTS

Test plot as follows:

Test channel

01

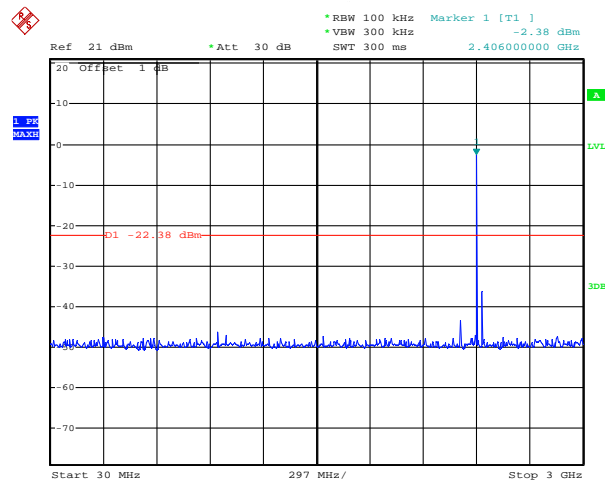

Date: 17.APR.2014 15:52:38

30MHz~3GHz

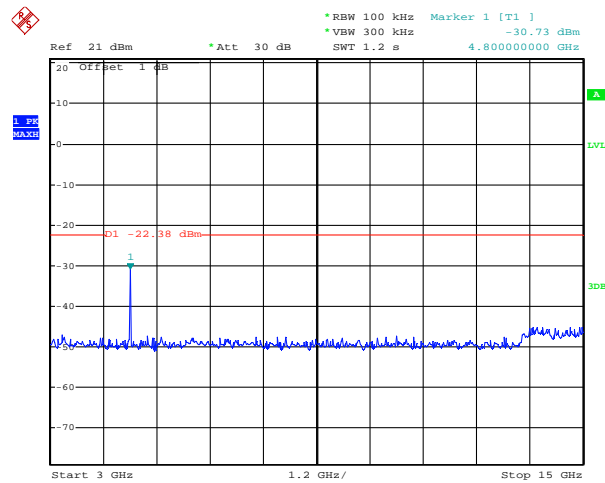

Date: 17.APR.2014 15:52:56

3GHz~15GHz

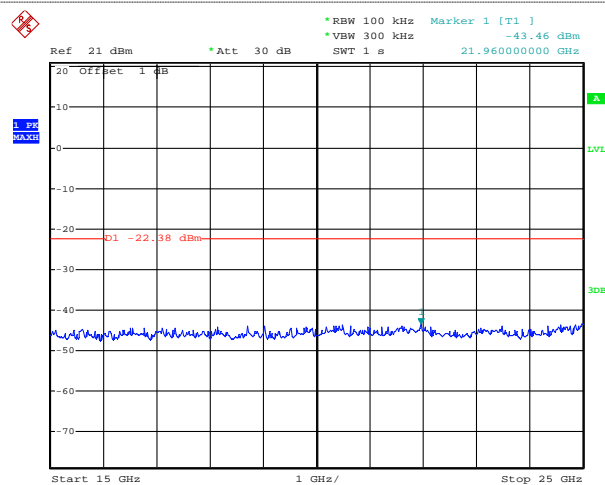

Date: 17.APR.2014 15:53:12

15GHz~25GHz

Test channel

20

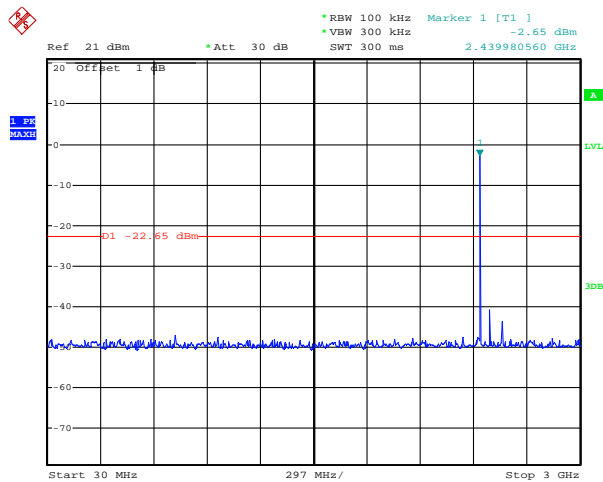

Date: 17.APR.2014 15:49:28

30MHz~3GHz

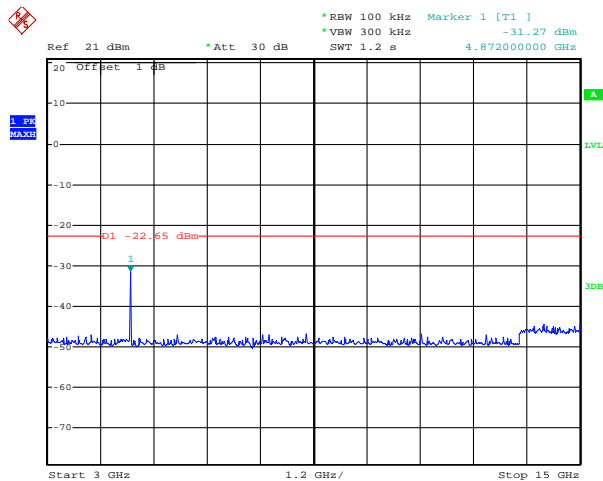

Date: 17.APR.2014 15:49:58

3GHz~15GHz

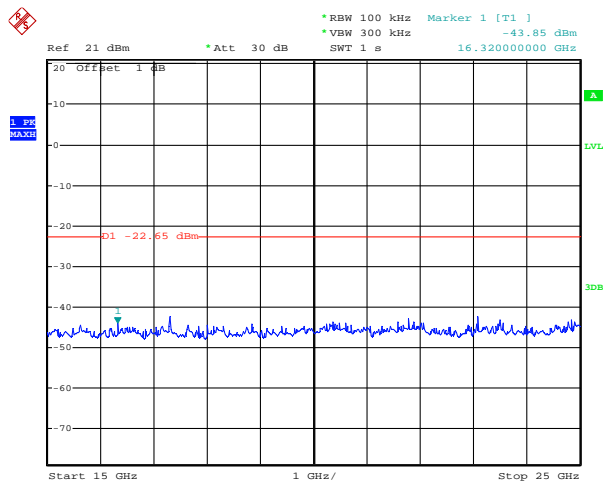

Date: 17.APR.2014 15:50:18

15GHz~25GHz

Test channel

40

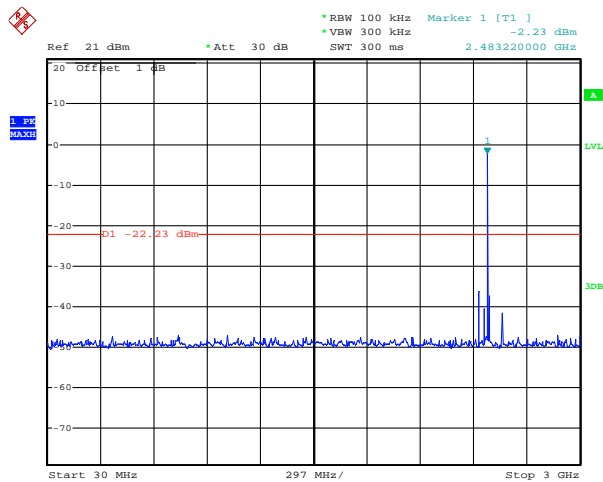

Date: 17.APR.2014 15:51:16

30MHz~3GHz

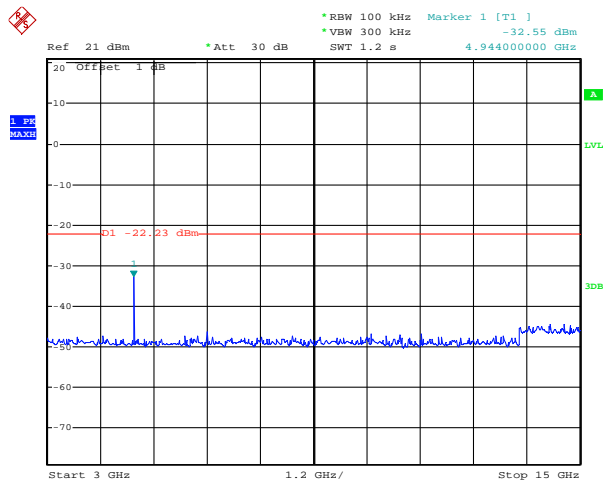

Date: 17.APR.2014 15:51:48

3GHz~15GHz

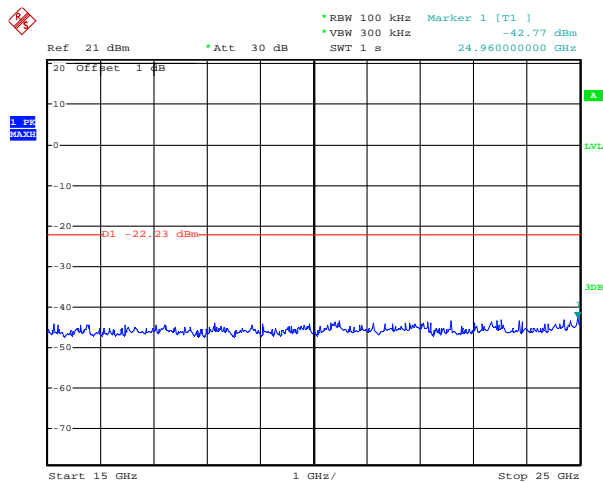

Date: 17.APR.2014 15:52:04

15GHz~25GHz

4.7. Spurious Emission (radiated)

LIMIT

FCC CFR Title 47 Part 15 Subpart C Section 15.209

Frequency	Limit (dBuV/m @3m)	Value
30MHz-88MHz	40.00	Quasi-peak
88MHz-216MHz	43.50	Quasi-peak
216MHz-960MHz	46.00	Quasi-peak
960MHz-1GHz	54.00	Quasi-peak
Above 1GHz	54.00	Average
	74.00	Peak

TEST CONFIGURATION

- Below 30MHz

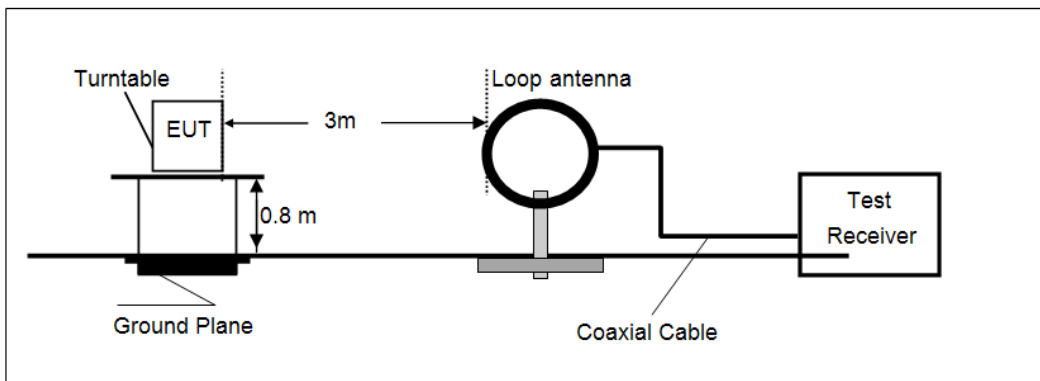

- 30MHz~1000MHz

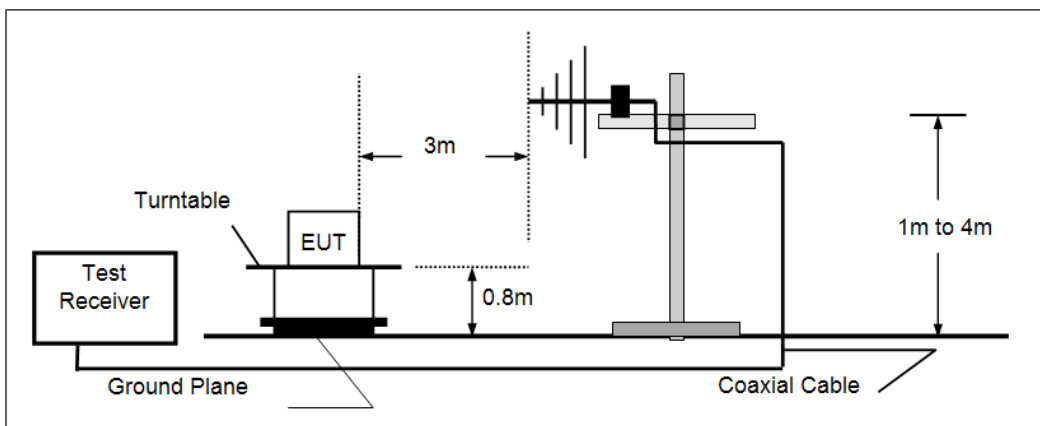

- Above 1GHz

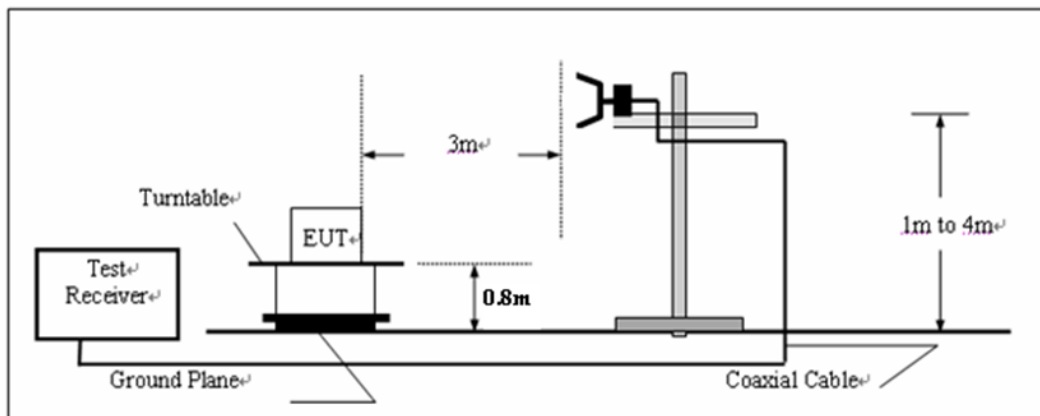

TEST PROCEDURE

1. The EUT was placed on the top of a rotating table 0.8 meters above the ground at a 3 meter camber. The table was rotated 360 degrees to determine the position of the highest radiation.
2. The EUT was set 3 meters away from the interference-receiving antenna, which was mounted on the top of a variable-height antenna tower.
3. The antenna height is varied from one meter to four meters above the ground to determine the maximum value of the field strength. Both horizontal and vertical polarizations of the antenna are set to make the measurement.
4. For each suspected emission, the EUT was arranged to its worst case and then the antenna was tuned to heights from 1 meter to 4 meters and the rota table was turned from 0 degrees to 360 degrees to find the maximum reading.
5. The test-receiver system was set to Peak Detect Function and Specified Bandwidth with Maximum Hold Mode.

TEST RESULTS

Below 1GHz

Horizontal

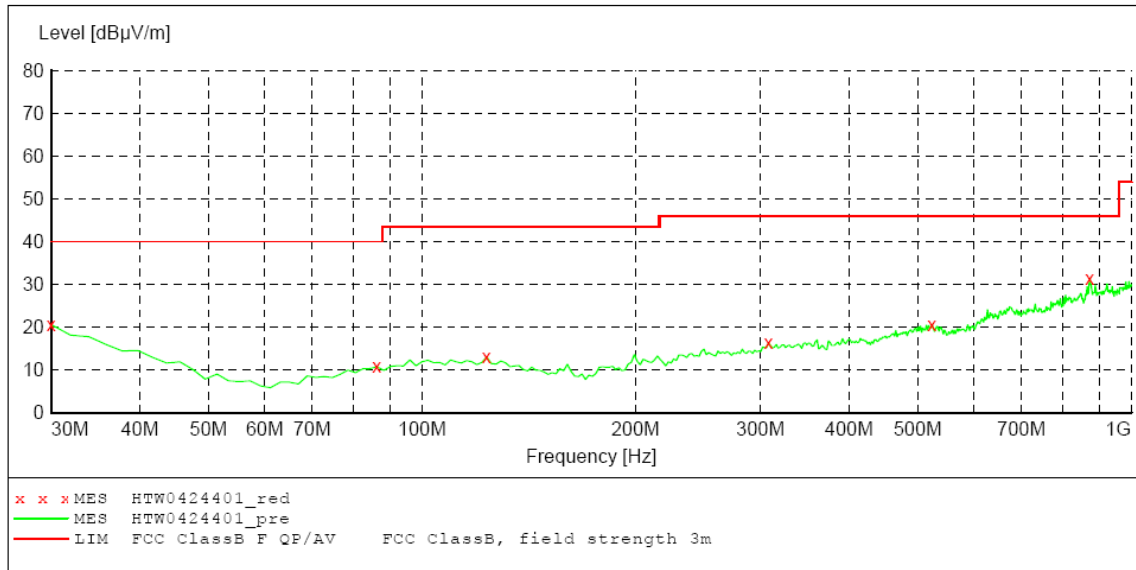

Frequency MHz	Level dBµV/m	Transd dB	Limit dBµV/m	Margin dB
30.000000	20.60	-10.0	40.0	19.4
86.372745	10.80	-19.4	40.0	29.2
123.306613	13.00	-18.0	43.5	30.5
307.975952	16.40	-14.8	46.0	29.6
523.747495	20.70	-11.0	46.0	25.3
873.647295	31.40	-4.4	46.0	14.6

Vertical

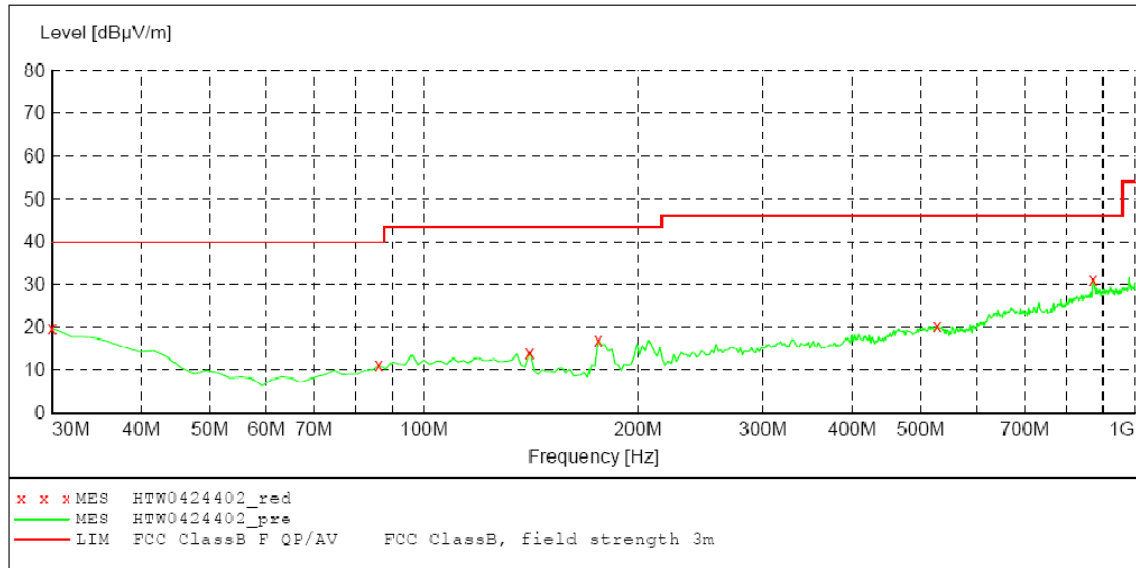

Frequency MHz	Level dBµV/m	Transd dB	Limit dBµV/m	Margin dB
30.000000	19.70	-10.0	40.0	20.3
86.372745	11.10	-19.4	40.0	28.9
140.801603	13.90	-20.1	43.5	29.6
175.791583	17.10	-21.0	43.5	26.4
527.635271	20.20	-11.0	46.0	25.8
873.647295	31.20	-4.4	46.0	14.8

■ Above 1GHz

Test channel:	01
---------------	----

Peak value:

Frequency (MHz)	Read Level (dBuV)	Antenna Factor (dB/m)	Cable Loss (dB)	Preamp Factor (dB)	Level (dBuV/m)	Limit Line (dBuV/m)	Margin (dB)	Polarization
4804.00	59.64	31.04	7.00	36.50	61.18	74.00	12.82	Vertical
7206.00	36.75	37.06	8.50	35.30	47.01	74.00	26.99	Vertical
9608.00	*					74.00		Vertical
12010.00	*					74.00		Vertical
4804.00	53.58	31.04	7.00	36.50	55.12	74.00	18.88	Horizontal
7206.00	33.47	37.06	8.50	35.30	43.73	74.00	30.27	Horizontal
9608.00	*					74.00		Horizontal
12010.00	*					74.00		Horizontal

Average value:

Frequency (MHz)	Read Level (dBuV)	Antenna Factor (dB/m)	Cable Loss (dB)	Preamp Factor (dB)	Level (dBuV/m)	Limit Line (dBuV/m)	Margin (dB)	Polarization
4804.00	37.48	31.04	7.00	36.50	39.02	54.00	14.98	Vertical
7206.00	24.22	37.06	8.50	35.30	34.48	54.00	19.52	Vertical
9608.00	*					54.00		Vertical
12010.00	*					54.00		Vertical
4804.00	33.36	31.04	7.00	36.50	34.90	54.00	19.10	Horizontal
7206.00	21.97	37.06	8.50	35.30	32.23	54.00	21.77	Horizontal
9608.00	*					54.00		Horizontal
12010.00	*					54.00		Horizontal

Test channel:	20
---------------	----

Peak value:

Frequency (MHz)	Read Level (dBuV)	Antenna Factor (dB/m)	Cable Loss (dB)	Preamp Factor (dB)	Level (dBuV/m)	Limit Line (dBuV/m)	Margin (dB)	Polarization
4880.00	57.69	31.58	7.33	36.43	60.17	74.00	13.83	Vertical
7320.00	38.07	37.84	8.60	35.30	49.21	74.00	24.79	Vertical
9760.00	*					74.00		Vertical
12200.00	*					74.00		Vertical
4880.00	54.42	31.58	7.33	36.43	56.90	74.00	17.10	Horizontal
7320.00	35.29	37.84	8.60	35.30	46.43	74.00	27.57	Horizontal
9760.00	*					74.00		Horizontal
12200.00	*					74.00		Horizontal

Average value:

Frequency (MHz)	Read Level (dBuV)	Antenna Factor (dB/m)	Cable Loss (dB)	Preamp Factor (dB)	Level (dBuV/m)	Limit Line (dBuV/m)	Margin (dB)	Polarization
4880.00	36.95	31.58	7.33	36.43	39.43	54.00	14.57	Vertical
7320.00	25.77	37.84	8.60	35.30	36.91	54.00	17.09	Vertical
9760.00	*					54.00		Vertical
12200.00	*					54.00		Vertical
4880.00	33.83	31.58	7.33	36.43	36.31	54.00	17.69	Horizontal
7320.00	22.58	37.84	8.60	35.30	33.72	54.00	20.28	Horizontal
9760.00	*					54.00		Horizontal
12200.00	*					54.00		Horizontal

Remark:

1. Final Level = Receiver Read level + Antenna Factor + Cable Loss – Preamplifier Factor
2. “*”, means this data is the too weak instrument of signal is unable to test.
3. The emission levels of other frequencies are very lower than the limit and not show in test report.

Test channel:	40
---------------	----

Peak value:

Frequency (MHz)	Read Level (dBuV)	Antenna Factor (dB/m)	Cable Loss (dB)	Preamp Factor (dB)	Level (dBuV/m)	Limit Line (dBuV/m)	Margin (dB)	Polarization
4960.00	57.45	31.76	7.53	36.36	60.38	74.00	13.62	Vertical
7440.00	37.82	38.53	8.71	35.30	49.76	74.00	24.24	Vertical
9920.00	*					74.00		Vertical
14880.00	*					74.00		Vertical
4960.00	53.37	31.76	7.53	36.36	56.30	74.00	17.70	Horizontal
7440.00	34.42	38.53	8.71	35.30	46.36	74.00	27.64	Horizontal
9920.00	*					74.00		Horizontal
14880.00	*					74.00		Horizontal

Average value:

Frequency (MHz)	Read Level (dBuV)	Antenna Factor (dB/m)	Cable Loss (dB)	Preamp Factor (dB)	Level (dBuV/m)	Limit Line (dBuV/m)	Margin (dB)	Polarization
4960.00	36.98	31.76	7.53	36.36	39.91	54.00	14.09	Vertical
7440.00	24.17	38.53	8.71	35.30	36.11	54.00	17.89	Vertical
9920.00	*					54.00		Vertical
14880.00	*					54.00		Vertical
4960.00	34.07	31.76	7.53	36.36	37.00	54.00	17.00	Horizontal
7440.00	22.16	38.53	8.71	35.30	34.10	54.00	19.90	Horizontal
9920.00	*					54.00		Horizontal
14880.00	*					54.00		Horizontal

Remark:

1. *Final Level = Receiver Read level + Antenna Factor + Cable Loss – Pre-amplifier Factor*
2. *“*”*, means this data is the too weak instrument of signal is unable to test.
3. *The emission levels of other frequencies are very lower than the limit and not show in test report.*

5. Test Setup Photos of the EUT

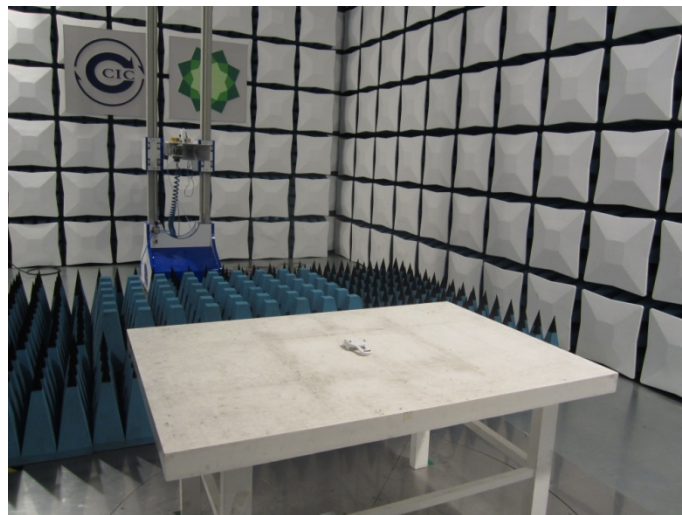

6. External and Internal Photos of the EUT



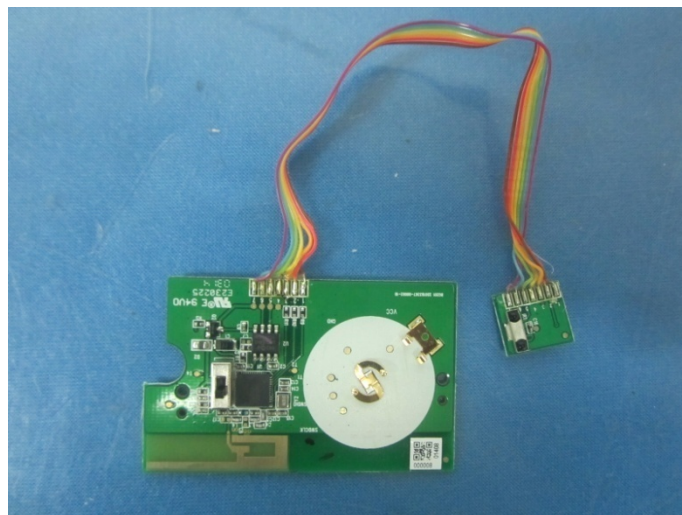
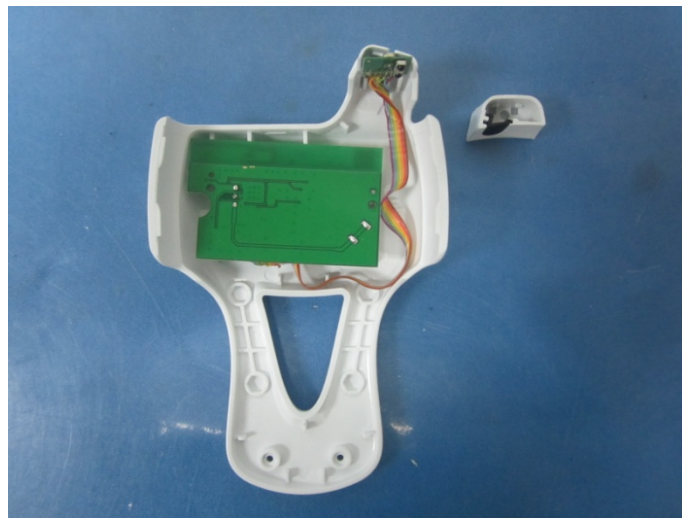
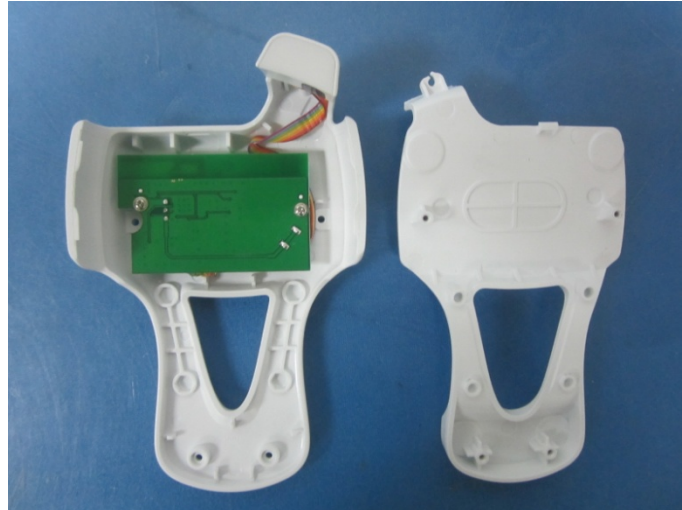

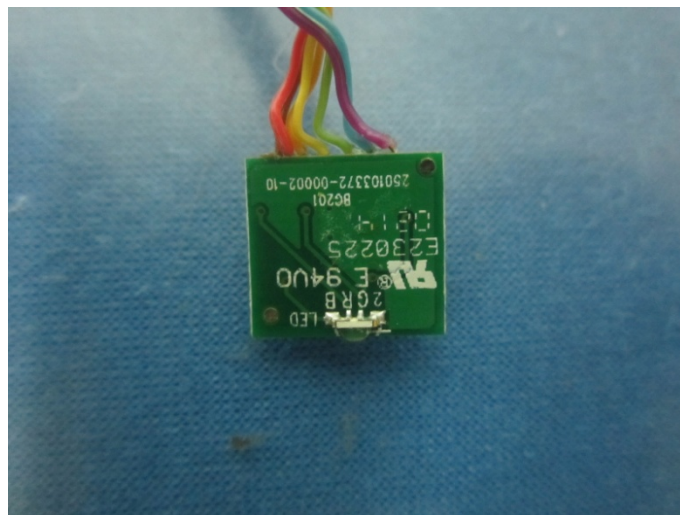
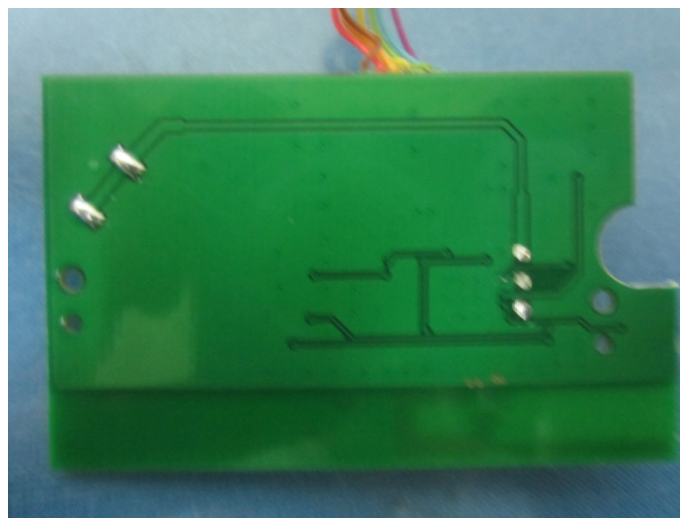
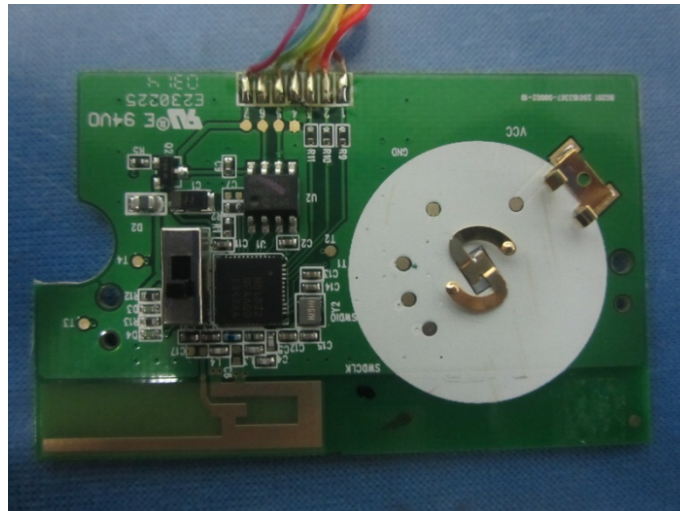

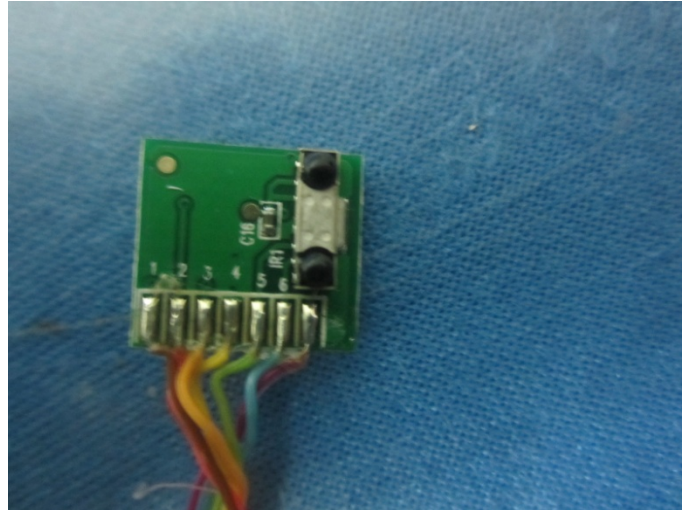

.....End of Report.....