

AD202 Block

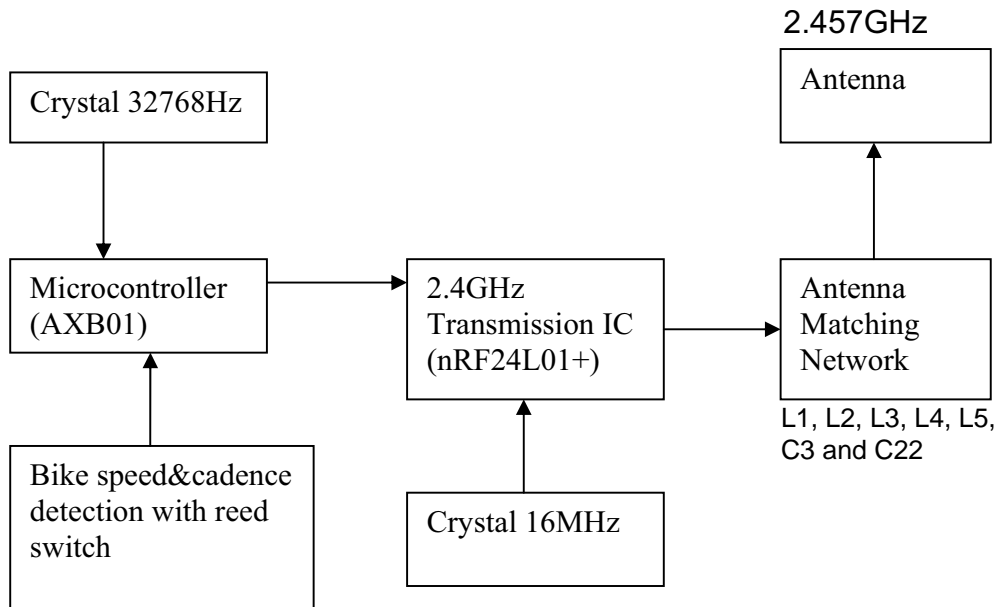

1.2 Block diagram

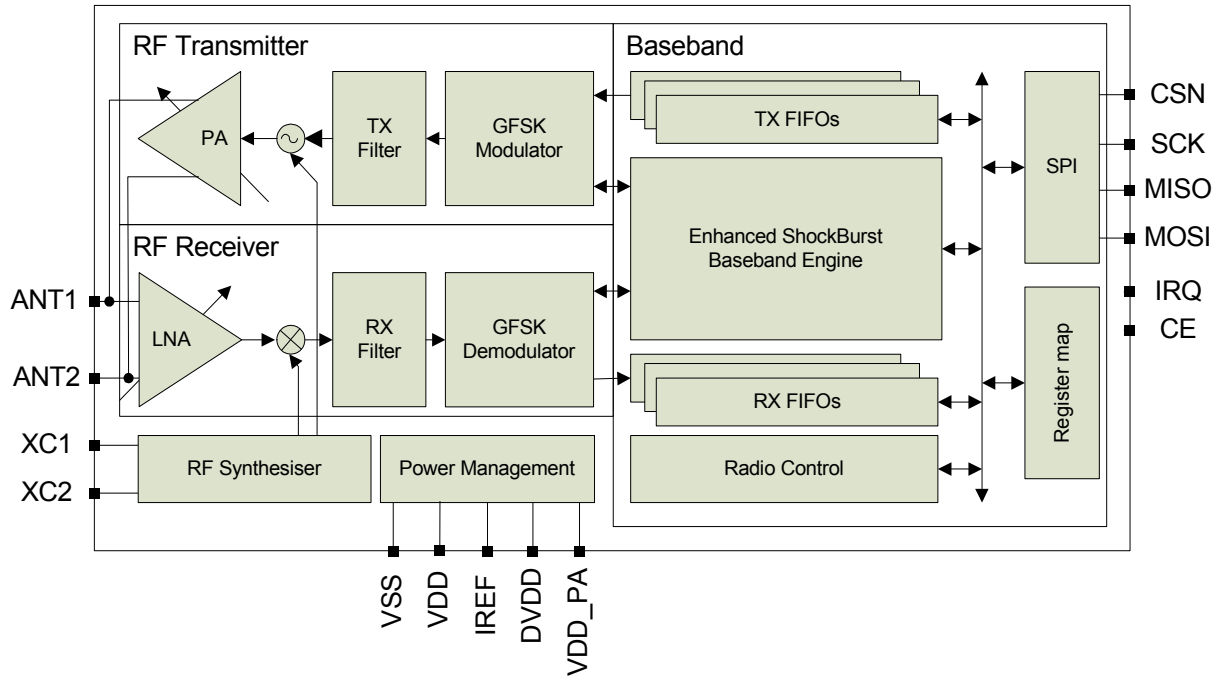

Figure 1. nRF24L01+ block diagram