

EXHIBIT V – Technical Report

FCC ID# NMEAVTS1010

Measurement/Technical Report

Data Critical Corporation., AVTS1010

FCC ID: NMEAVTS1010

April 9, 2000

This report concerns (check one):		Original Grant <input checked="" type="checkbox"/>	Class II Change <input type="checkbox"/>
Equipment Type <u>Licensed, Non-Broadcast Station Transmitter</u>			
Deferred grant requested per 47 CFR 0.457 (d)(1)(ii)?		yes <input type="checkbox"/> no <input checked="" type="checkbox"/>	
If yes, defer until:		<u>N/A</u> date	
<u>Data Critical Corporation</u> agrees to notify the Commission by:		<u>N/A</u> date	
of the intended date of announcement of the product so that the grant can be issued on that date.			
Report prepared by:	Northwest EMC, Inc. 22975 NW Evergreen Parkway, Suite 400 Hillsboro, OR 97124 (503) 844-4066 fax: (503) 844-3826		
Report No. DATC0004			





Table of Contents

Section	Description	Page
1.0	General Information	3
1.1	Product Description	3
1.2	Related Submittals/Grants	6
1.3	Tested System Details	6
1.4	Test Methodology	7
1.5	Test Facility	7
2.0	Technical Description	8
2.1	Type of Emission	8
2.2	Frequency Range	8
2.3	Operating Power Level	8
2.4	DC Voltage and Current Applied	8
2.5	Schematics and Bill of Materials	8
2.6	Block Diagram	8
2.7	Circuit Description	9
2.8	Tune Up Procedure	9
2.9	Description of Modulation System	9
Figure 2.1	Configuration of Tested System	10
3.0	RF Conducted Power Output	11
4.0	Modulation Characteristics	12
5.0	Necessary Bandwidth	13
6.0	Occupied Bandwidth	15
7.0	Spurious Emissions at Antenna Terminals	16
8.0	Field Strength of Spurious Radiation	17
9.0	Frequency Stability	20
10.0	Transient Frequency Behavior	21
11.0	Measurement Equipment	22
Appendix I Antenna Specifications		23

1.0 General Information

1.1 Product Description

Manufactured By Data Critical Corporation.
Address..... 19820 North Creek Parkway, Suite 100 Bothell, WA 98011
Test Requested By:..... Christopher Hartzog
Model..... AVTS1010
FCC ID..... NMEAVTS1010
Applicable FCC Rule Part(s)..... 90.31, 90.22, 90.238
Serial Number(s) N/A
Date of Test March 17, 2000 through April 9, 2000
Job Number DATC0004

Prepared By:  Vicki Albertson, Technical Report and Documentation Manager	Administrative Review By:  Brenda Wood, Technical Report Writer
Technical Review By:  Greg Kiemel, Director of Engineering	Approved By:  Dean Ghizzone, President

1.1 Product Description con't

The Data Critical Corporation AlarmView AVTS1010 is a secondary alarm notification system that transmits alarm data from Primary Patient Monitoring Equipment (PME) to pagers that are worn by caregivers. The system consists of the following:

- ?? The AlarmView Pager – The AlarmView Pager is an off the shelf pager that is worn by caregivers responsible for individual patient care.
- ?? The AlarmView Programmer – The AlarmView Programmer is an off the shelf Personal Digital Assistant (PDA) with Windows CE operating system and equipped with AlarmView programming software. The PDA needs to have an infrared (IR) port to communicate with the transmitter.
- ?? The AlarmView Transmitter (EUT) – The AlarmView Transmitter is connected to the Patient Monitoring Equipment (PME) (i.e. Nellcor Puritan Bennett Pulse Oximeter – NPB-290, NPB-295, NPB-3000) with an AlarmView cable that is connected to the PME's serial port. The transmitter is Data Critical Corporation's proprietary RF transmitter operating in the UHF band (450-466MHz). It has a BNC connector for the antenna needed for the RF transmissions, an IR port used for setup, a button for power on/off and certain user initiated transmissions, and an RJ-45 connector for connection with the Patient Monitoring Equipment. The AVTS1010 transmitter contains a Digital Processor Board and an off the shelf OEM transceiver module manufactured by Dataradio, Inc., Dataradio model DM-3474, part number 242-3474-510.

The EUT is the AlarmView Transmitter. ***Please see the Theory of Operations, Exhibit "A", file name: Theory of Operations.PDF***

Hardware Description:

- ?? Clocks/Oscillators Frequencies: On the AlarmView Digital Processor PCB, there are crystal controlled clock oscillators of 48MHz and 18.432MHz. On the Dataradio DM-3474 transceiver module, there is a 17.5MHz voltage controlled TCXO and a VCO which operates from 450-466 MHz in transmit and 502.95-518.95MHz in receive mode. In receive mode, the VCO output serves as the source for high side injection of the first receiver mixer. A second receive mixer and 450kHz 2nd LO are contained in U241, the 2nd IF and demodulator IC.
- ?? Ports: Data Port (for connection to Patient Monitor-not to a PC)
- ?? Antenna: Centurion Model EXC, ¼ wave helical flexible antenna (additional information may be referenced in Appendix I)
- ?? Frequency Range: 450-466MHz
- ?? Output Power: 400 mW
- ?? Modulation: POCSAG
- ?? Channel Bandwidth: 25kHz
- ?? Channel Spacing: 12.5kHz
- ?? Frequency Stability: 1.5PPM
- ?? Data rate: 2400bps
- ?? Emission Designator: F1D

1.2 Related Submittals/Grants

None.

1.3 Tested System Details

EUT and Peripherals

Item	Description and Serial No.
EUT	Data Critical Corporation Model AVTS1010, FCC ID NMEAVTS1010.
Patient Monitor	Nellcor Model NPB-295, Serial No. 21672473.
Patient Simulator	Nellcor Model SRC-2, Serial No. 21512643.

Cables:

Patient cable	3.25 meters in length, shielding unknown, with ferrites.
Data cable	0.3 meters in length, shielded, no ferrites.
Monitor power	2.5 meters in length, unshielded, no ferrites.
DC Power	1.8 meters in length, unshielded, no ferrites.
AC Power	1.8 meters in length, unshielded, no ferrites.

1.4 Test Methodology

TIA/EIA-603 (1993)

1.5 Test Facility

The Open Area Test Site and conducted measurement facility used to collect the radiated and conducted data is located at

Northwest EMC, Inc.
22975 NW Evergreen Parkway, Suite 400
Hillsboro, OR 97124
(503) 844-4066
Fax: 844-3826

The semi-anechoic chamber, and conducted measurement facility used to collect this data is located at the address shown above. This site has been fully described in a report filed with the FCC, dated August 13, 1999, and accepted by the FCC in a letter dated August 30, 1999 (95296).

Northwest EMC, Inc. is recognized under the United States Department of Commerce, National Institute of Standards and Technology, National Voluntary Laboratory Accreditation Program (NVLAP) for satisfactory compliance with criteria established in Title 15, Part 285 Code of Federal Regulations. These criteria encompass the requirements of ISO/IEC Guide 25 and the relevant requirements of ISO 9002 (ANSI/ASQC Q92-1987) as suppliers of calibration or test results. NVLAP Lab Code: 200059-0.

2.0 Technical Description

2.1 Type of Emission

The device has F1D emission.

2.2 Frequency Range

The device has a frequency range of 450 – 466 MHz.

2.3 Operating Power Level

The power output for the AVTS1010 device is fixed at 400 mW at the factory with no means for the user to change it. The transceiver module within the AVTS1010 is capable of a 2 watt output when powered from a 7.5V source. The manufacturer operates the transceiver at 6.5V for a nominal 1.4W output and inserts 7.0dB of attenuation between the output and the antenna terminal to reduce it to 400 mW.

2.4 DC Voltage and Current Applied

The voltage/current into the final amplifier transistor is 6.4VDC and 600mA into Q541.

2.5 Schematics and Bill of Materials

Schematic diagrams of all circuitry and devices provided for determining and stabilizing frequency, for suppression of spurious radiation, for limiting modulation, and for limiting power are provided as separate attachments.

Schematics may be referenced in Exhibit “B”, file name: Schematics.PDF, Exhibit “C”, file name: Schematics2.PDF, and Exhibit “K”, file name: VCO Schematic.PDF

The Bill of Materials may be referenced in Exhibit “D”, file name: Bill of Materials.PDF

2.6 Block Diagram

A Block Diagram of all circuitry and devices provided for determining and stabilizing frequency, for suppression of spurious radiation, for limiting modulation, and for limiting power are provided as separate attachments..

Block Diagrams may be referenced in Exhibit “E”, file name: Transceiver Block Diagram.PDF, and Exhibit “F”, file name: System Block Diagram.PDF.

2.7 Circuit Description

A circuit description (relating to the block diagram) of all circuitry and devices provided for determining and stabilizing frequency, for suppression of spurious radiation, for limiting modulation, and for limiting power is provided as a separate attachment.

A circuit description may be referenced in Exhibit "P", file name: Circuit Description and Tune-up Procedure.PDF.

2.8 Tune-up Procedure

A description of the Tune-up procedure is provided as a separate attachment.

A Tune-up procedure may be reference in Exhibit "P", file name: Circuit Description and Tune-up Procedure.PDF

2.9 Description of Modulation System

The following is a detailed description of the modulation system to be used, including the response characteristics (frequency, phase, and amplitude) of any filters provided, and a description of the modulating wavetrain, for the maximum rated conditions under which the equipment will be operated:

The Micro-Controller U15 generates serial POCSAG paging data out pin 40 (TxData). The voltage levels of the data are 0VDC and 5VDC. The digital data can be 512, 1200, or 2400 bps. The digital data then passes through an inverter U13 which acts as an inverting buffer. The output of the inverter is fed to a summing amplifier U8A which has the following equation:

$$V_{out}=2.5(\text{Gain} + 1) - \text{Gain} * V_{in}$$

where Gain = R_b/R_a , is controlled by potentiometer R12 (or R136 depending upon which model of potentiometer is installed) and may be set to any value in the range of 0.093 to 0.348 nominal.

R_b = the sum of resistances of resistors R13 and potentiometer R12 (or R136).

R_a = the sum of resistances of resistors R127 and R15.

V_{IN} = voltage at U13, pin 4.

The digital signal then passes through a low pass filter section. U9A, B, and C form three cascaded Sallen & Key type low pass filters. The low-pass filter has 1dB and 3dB cutoff frequencies of 3.7kHz and 5.8kHz.

The output of the low pass filter is fed to a DC block comprised of C15 and R22. The 3dB cutoff frequency is about 3.6Hz and the output is shifted to be centered around 2.5 VDC. The output of the DC block is buffered with U9D whose output is connected to the Data Radio 3474's Data In pin.

***Schematics may be referenced in Exhibit "B", file name: Schematics.PDF, Exhibit "C", file name: Schematics2.PDF, and Exhibit "K", file name: VCO Schematic.PDF
Modulation Wavetrain Scope Plot may be referenced in Exhibit "G", file name: Modulating Wavetrain Scope.PDF and Bode Plots of Filters may be referenced in Exhibit "H", file name: Bode Plots.PDF***

Figure 2.1: Configuration of Tested System

AlarmView Transmitter FCC Testing Equipment Setup

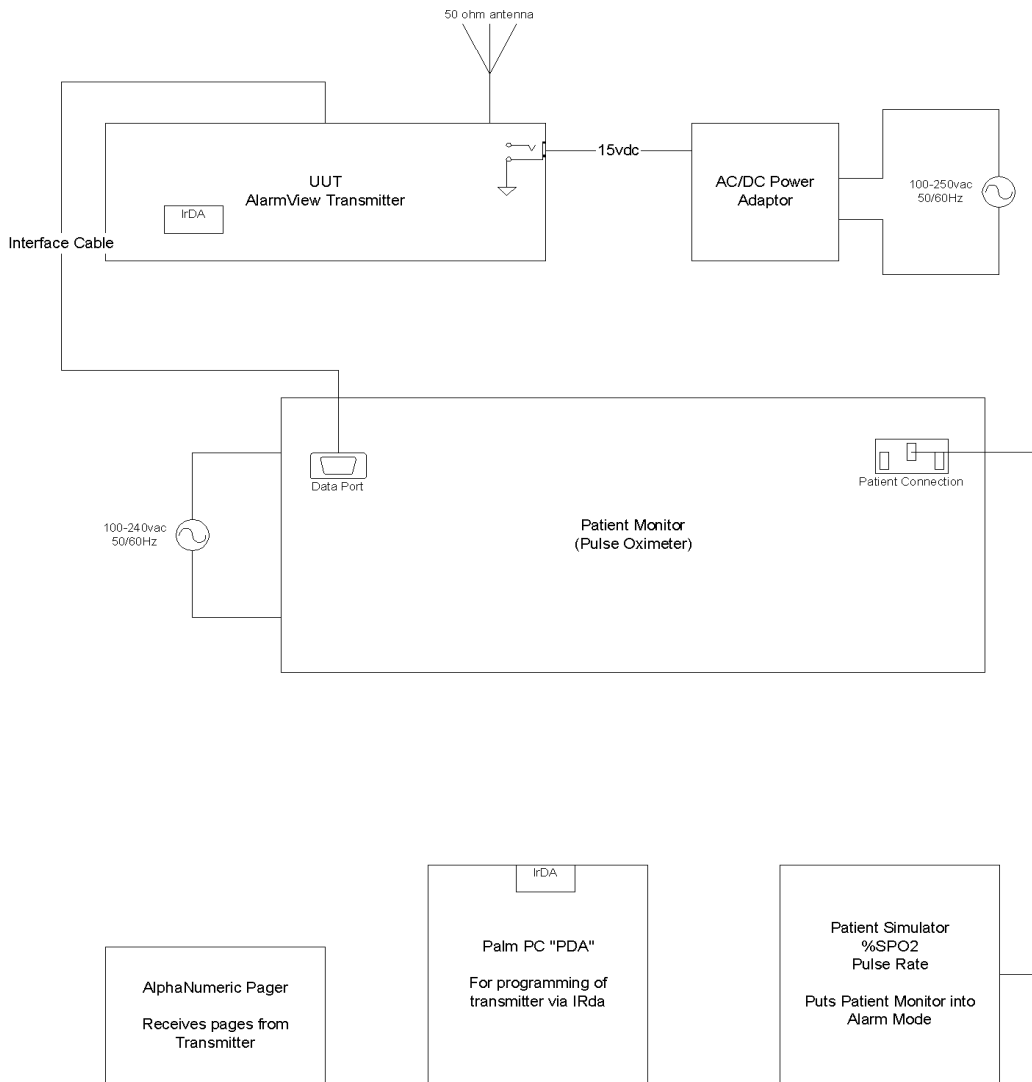

3.0 RF Conducted Power Output Data

Reference 2.1046 and 90.205

The Conducted Power Output was measured at the RF output terminals after the tune-up procedure. The measured value, the value stated in the manual, and the value on Form 731 must agree. Typically, the FCC will allow the Form 731 to state a value up to 2 dB over the measured value to allow for manufacturing variances, tolerances, etc.

A spectrum analyzer or power meter may be used to measure the output power of the unmodulated carrier. If using a spectrum analyzer, the resolution bandwidth should be greater than the 6dB bandwidth of Xmit signal.

An external attenuator or directional coupler is usually needed.

Data Critical measurements were made at high, mid, and low transmit frequencies within the 450-466 MHz band. The EUT was configured to 2400 b.p.s. A spectrum analyzer with a 20dB pad was used to make the measurement. The RBW and VBW were much greater than the 6dB bandwidth of the EUT.

Test Setup

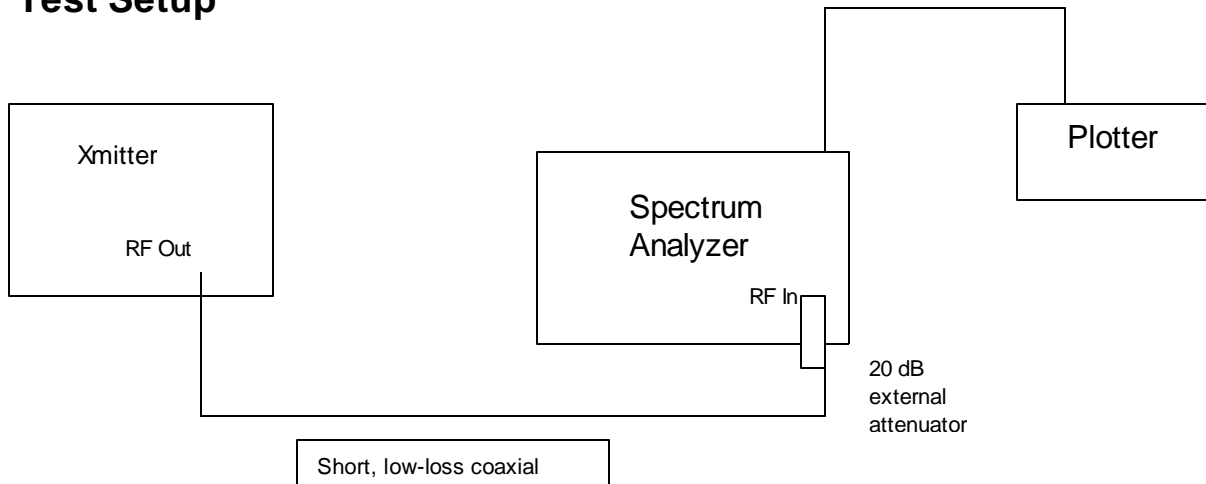

3.1 Test Results

Low Frequency	Mid Frequency	High Frequency
255.86mW	281.19mW *	263.03mW

Reference Exhibit "I", file name Output Power.PDF for the data plots.

* Note: The FCC Form 731 reflects this maximum measured output power level plus 2dB (tolerance permitted by the Commission)

4.0 Modulation Characteristics Data

Reference 2.1047 (Audio characteristics not required for data transmitters), 90.211, and 2.1033(c)(13)

The emission designator “F1D” was selected based upon the guidelines in CFR 2.201: “F” designates an emission in which the main carrier is frequency modulated. “1” designates a single channel containing digital information without the use of a modulating sub-carrier (the applicant confirmed that no sub-carriers are used). “D” designates data transmission, telemetry or telecommand. As detailed in the user manual, the device is used to transmit one way, non-voice, telemetry signals.

For telemetry operations, only A1D, A2D, F1D, and F2D emissions are authorized. The EUT utilizes F1D emissions.

The Micro-Controller U15 generates serial POCSAG paging data out pin 40 (TxData). The voltage levels of the data are 0VDC and 5VDC. The digital data can be 512, 1200, or 2400 bps. The digital data then passes through an inverter U13 which acts as an inverting buffer. The output of the inverter is fed to a summing amplifier U8A which has the following equation:

$$V_{out} = 2.5(\text{Gain} + 1) - \text{Gain} * V_{in}$$

where $\text{Gain} = R_b/R_a$, is controlled by potentiometer R12 (or R136 depending upon which model of potentiometer is installed) and may be set to any value in the range of 0.093 to 0.348 nominal.

R_b = the sum of resistances of resistors R13 and potentiometer R12 (or R136).

R_a = the sum of resistances of resistors R127 and R15.

V_{IN} = voltage at U13, pin 4.

The digital signal then passes through a low pass filter section. U9A, B, and C form three cascaded Sallen & Key type low pass filters. The low-pass filter has 1dB and 3dB cutoff frequencies of 3.7kHz and 5.8kHz.

The output of the low pass filter is fed to a DC block comprised of C15 and R22. The 3dB cutoff frequency is about 3.6Hz and the output is shifted to be centered around 2.5 VDC. The output of the DC block is buffered with U9D whose output is connected to the Data Radio 3474's Data In pin.

Schematics may be referenced in Exhibit “B”, file name: Schematics.PDF, Exhibit “C”, file name: Schematics2.PDF, and Exhibit “K”, file name: VCO Schematic.PDF

Modulation Wavetrain Scope Plot may be referenced in Exhibit “G”, file name: Modulating Wavetrain.PDF and Bode Plots of Filters may be referenced in Exhibit “H”, file name: Bode Plots.PDF

5.0 Necessary Bandwidth

Reference 2.202(b)

To simplify the calculation of the necessary bandwidth, this basic strategy was employed. The power distribution function (PDF) for a random binary signal was used to evaluate the frequencies where 95% of the modulation's power falls. The PDF for modulation of this type is a $[\sin(x)/x]^2$ type function and approximately 95% of its power is contained within the range from DC to the second minima. This second minima criteria was used for all three baud rates. This frequency is considered to be the bandwidth (W) of the modulating signal.

Having obtained the modulating signal's bandwidth W, Carson's rule was applied to the system to determine the necessary BW of the FM system. The results are as follows:

Baud	Necessary BW [Hz]
512	11,050 Hz
1200	13,800 Hz
2400	18,600 Hz

A detailed description of the process is as follows.

Determining the Maximum Fundamental Frequency of each Baud Rate:

The power density function (PDF) for a random binary sequence is described by¹

$$G(f) = T \left(\frac{\sin(\pi f T)}{\pi f T} \right)^2$$

where: G(f) = the **double sided** PDF as a function of frequency
 T = the bit period
 f = frequency

A factor of 2 was added in calculations so that G(f) would represent a "real world" **single sided** description of the frequency content of the modulation.

Determining the Bandwidth of the Modulating Signal:

Upon evaluating the integral of G(f) over frequency, it will be shown that 95% of the power in the modulating signal is contained within the frequencies bounded by DC and the second minima. The second minima for the baud rates of 512, 1200, and 2400 are at 1024, 2400, and 4800 Hz respectively. Since the 6-pole anti-splatter filter has a 3dB cutoff frequency of 5800 Hz, it has little effect on the two lower baud rates yet further forces the 2400 baud signal to be band limited to 4800 Hz.

Necessary Bandwidth con't

These maximum modulation frequencies were used as the bandwidth (W) in the evaluation of Carson's Rule.

Determining the Bandwidth of the FSK (modulated) Signal:

Carson's rule is²:

$$BW_{FM} \approx 2(D + 1)BW_{MOD}$$

where: BW_{FM} = the significant portion of the bandwidth of the modulated FM carrier

BW_{MOD} = the significant portion of the bandwidth of the modulating signal

D = the peak frequency deviation / BW_{MOD}

In theory, BW_{FM} is of infinite bandwidth, even when a sinusoidal modulating signal is used. Also, a squarewave or any other digital signal has infinite bandwidth too, thus the 95% power criteria was chosen to encompass only the "significant" harmonics of the modulating signal.

In all cases, the AlarmView transmitter will be adjusted for a peak frequency deviation of 4500Hz. Using the BW_{MOD} frequencies of 1024Hz, 2400Hz, and 4800Hz corresponding to baud rates of 512, 1200, and 2400 respectively, BW_{FM} levels were calculated as:

Baud	BW_{FM}
512	11,050 Hz
1200	13,800 Hz
2400	18,600 Hz

References:

1. Digital Communications, Bernard Sklar, 1988, Prentice Hall.
2. Principals of Communications, Ziemer, Tranter, 1990, Houghton Mifflin Co.

6.0 Occupied Bandwidth Data

Reference 47 CFR 90.210 and 2.1049

The Occupied Bandwidth was measured at the RF output terminals with analyzer plots made for each modulation type.

An external attenuator or directional coupler usually needed (Data Critical testing performed with 20dB external attenuator. This is compensated in analyzer – see PG –20dB at the top of each graph).

A 300Hz resolution bandwidth with no video filtering and a peak detector were used. Some transmitters may require a larger RBW (10kHz < 1 GHz, 100kHz > 1GHz) if they are broadband such as CDMA. It is important to use a RBW that is sufficiently narrow to plot the actual bandwidth of the signal and not the filter response curve of the spectrum analyzer.

The emission mask is shown on each plot. (The emission mask for Data Critical is Mask C defined in 47 CFR 90.210(c). The 0dB reference for the mask is the measured output power = 281mW = 24dBm).

The span was varied across 2 plots to clearly show compliance with the emission mask.

Data Critical measurements were made at high, mid, and low transmit frequencies within the 450-466 MHz band. The EUT was configured to 2400 b.p.s.

Test Setup

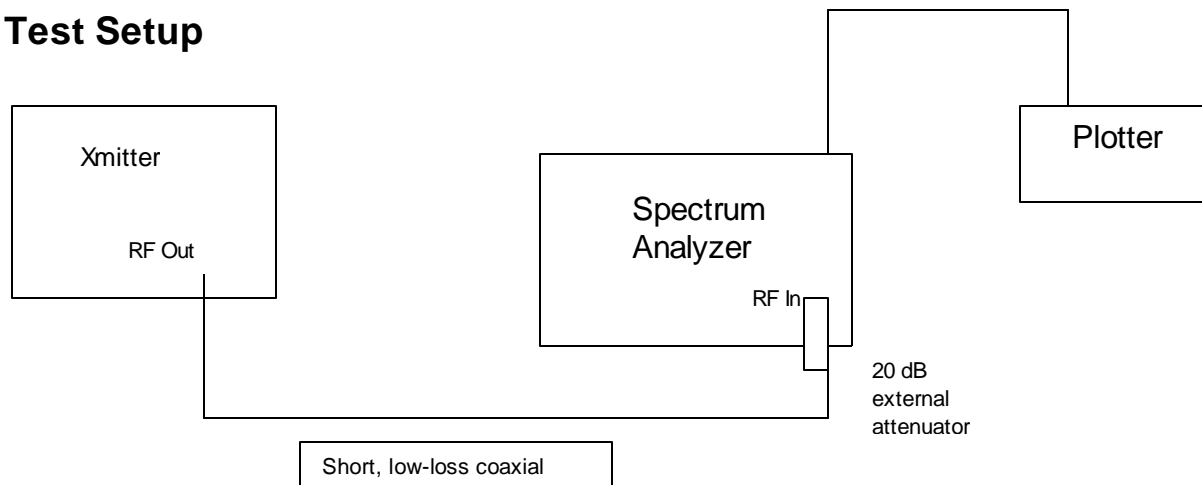

6.1 Test Results

Reference Exhibit "J", file name: Occupied Bandwidth.PDF for the data plots.

7.0 Spurious Emissions at Antenna Terminals Data

Reference 2.1051 and 90.210 (c)

The Spurious Emissions at the antenna terminals were measured at the RF output terminals with analyzer plots made for each modulation type.

A spectrum analyzer was used to scan from 0 to 5 GHz. A 10kHz resolution bandwidth was used below 1GHz and 100kHz above 1GHz. No video filtering was employed.

A 20dB external attenuator was used on the RF input of the spectrum analyzer.

Spurious emissions must be attenuated $43 + 10\log(\text{mean power}) = 43\text{dB}$

Data Critical measurements made at high, mid, and low transmit frequencies within the 450-466 MHz band. The EUT was configured to 2400 b.p.s.

Test Setup

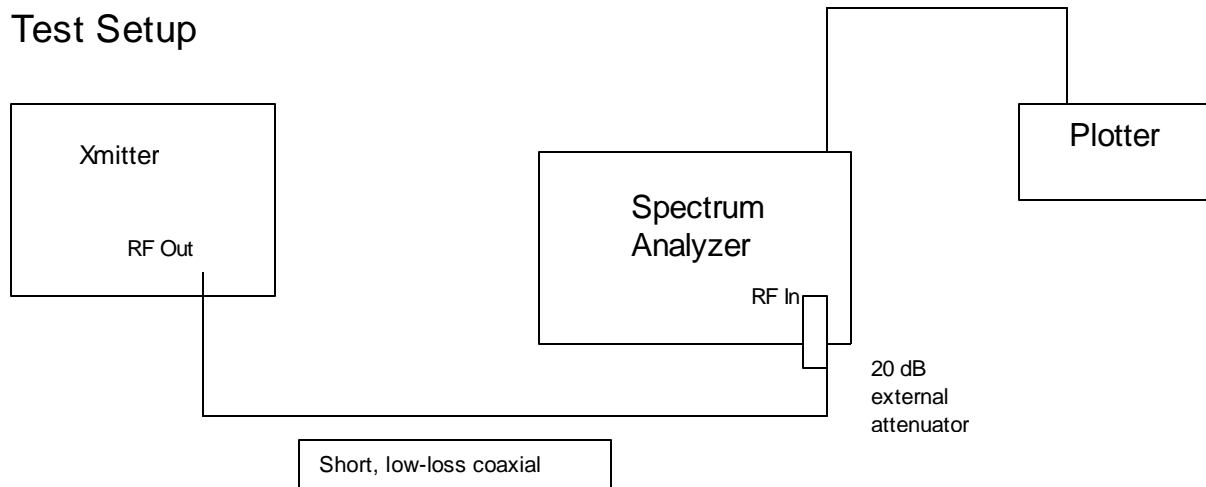

7.1 Test Results

Low Frequency		Mid Frequency		High Frequency	
900MHz	-65.8dBc	917MHz	-64.1dBc	930MHz	No detectable signal

Reference Exhibit "L", file name: Spurious Emissions @ Antenna Terminals.PDF for the data plots.

8.0 Field Strength of Spurious Radiation Data

Reference 2.1053 & 90.210(c)

The Field Strength of Spurious Radiation was measured in the far-field at an Open Area Test Site (OATS) up to 5GHz.

Spectrum analyzer and linearly polarized antennas were used to measure radiated harmonics and spurious emissions.

The orientation of the EUT and measurement antenna were manipulated to maximize the level of emissions.

The EUT was configured to transmit at the highest output power into a dummy load at mid band.

Although the substitution method is preferred: Limit = Mean output power - 43+10logP, an Alternate Limit at 3 meters of 84.3dBuV/m was used..

Radiated Spurious Emissions

Justification for 3 meter limit of 84.3 dBuV/m

For licensed transmitters, the FCC references TIA/EIA-603 as the measurement procedure standard. TIA/EIA-603 Section 2.2.12 describes a method for measuring radiated spurious emissions that utilizes an antenna substitution method:

At an Open Area Test Site, the transmitter is placed on a remotely controlled turntable, and the measurement antenna is placed 3 meters from the transmitter. The turntable azimuth is varied to maximize the level of spurious emissions. The height of the measurement antenna is also varied from 1 to 4 meters. The amplitude and frequency of the highest emissions are noted. The transmitter is then replaced with a ½ wave dipole that is successively tuned to each of the highest spurious emissions. A signal generator is connected to the dipole, and its output is adjusted to match the level previously noted for each frequency. By converting the generator output to Watts, and factoring in the cable loss to the dipole antenna; the power into a ½ wave dipole antenna is determined for each radiated spurious emission.

Clearly, this method doesn't work very well above 1GHz. Alternatively, the field strength of the spurious emissions can be measured and compared with a 3 meter limit. Usually, the 3 meter limit is 84.3 dBuV/m - irrespective of the output power of the device.

Field Strength of Spurious Radiation Data con't

Measured EUT Output Power = 24 dBm = 281mW

$$P_{\text{apparent}} = P_T / (4\pi d^2) = .281W / 4\pi 3^2 = .002484586W/m^2$$

$$W = V^2/R, \quad V = (W \cdot R)^{1/2} = (2.484586 \text{ E-3 W/m}^2 (377\pi))^1/2 = .9678268 \text{ V/m}$$

$$\text{dBuV/m} = 20\log(V/m \cdot 1E6) = 119.716 \text{ dBuV/m} = \text{Field Strength of Carrier at 3m}$$

90.210(c):

"43 + 10log(mean output power in Watts)dB."

43 + 10log(.281W) = 37.48706dB = The amount spurious emissions must be reduced below the level of the carrier.

$$119.716 \text{ dBuV/m} - 37.48706 \text{ dB} = 82.2 \text{ dBuV/m}$$

Referenced to a 1/2 wavelength tuned dipole: 82.2 dBuV/m + 2.1 dB = 84.3dBuV/m

84.3dBuV/m = 3meter limit for radiated spurious emissions.

Data Critical measurements were made at a mid transmit frequency within the 450-466 MHz band. The EUT was configured to 2400 b.p.s.

Field Strength of Spurious Radiation Data con't

Test Setup

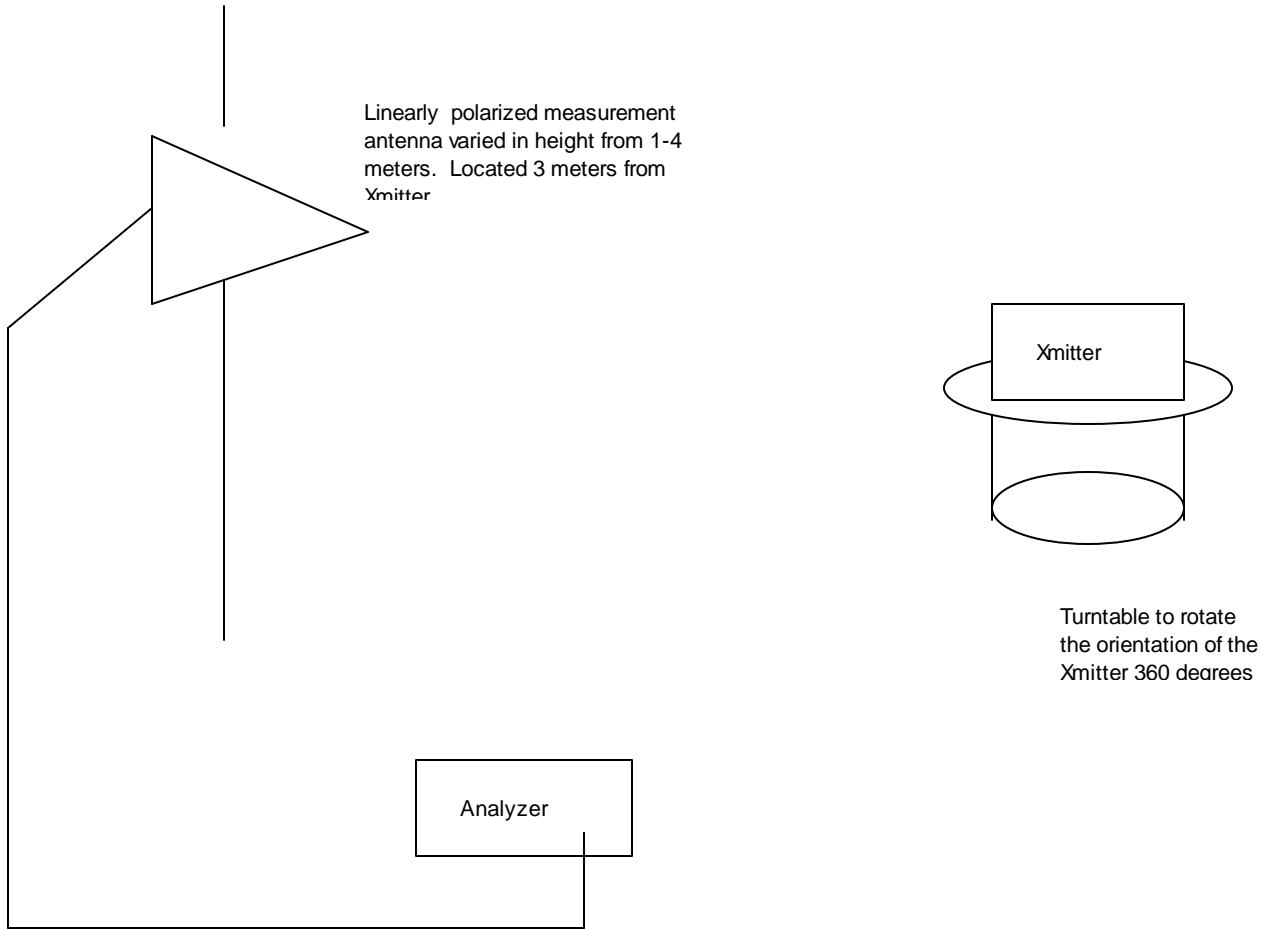

8.1 Test Results

Reference Exhibit "M", file name: *Field Strength of Spurious Radiation.PDF* for the data plots.

9.0 Frequency Stability Data

Reference 2.1055 & 90.213

The Frequency Stability was measured at the RF output terminals.

A spectrum analyzer or frequency counter can be used to measure the frequency stability. If using a spectrum analyzer, it must have a precision frequency reference that exceeds the stability requirement of the transmitter.

An external attenuator or directional coupler is usually needed.

A temperature / humidity chamber is also required.

Variation of Supply Voltage

The primary supply voltage was varied from 85% to 115% of nominal. Because the EUT can also be battery operated, the D.C. voltage was also varied and reduced to the EUT's voltage end point.

Variation of Ambient Temperature

Using a temperature chamber, the transmit frequency was recorded at the extremes of the specified temperature range (-30° to +50° C) and at 10°C intervals.

Data Critical measurements were made at a mid-transmit frequency within the 450-466 MHz band. The EUT was configured for CW operation. Temperature testing was performed at nominal AC line voltage. Variation of supply voltage measurements were performed for both AC and battery operation at ambient temperature.

Test Setup

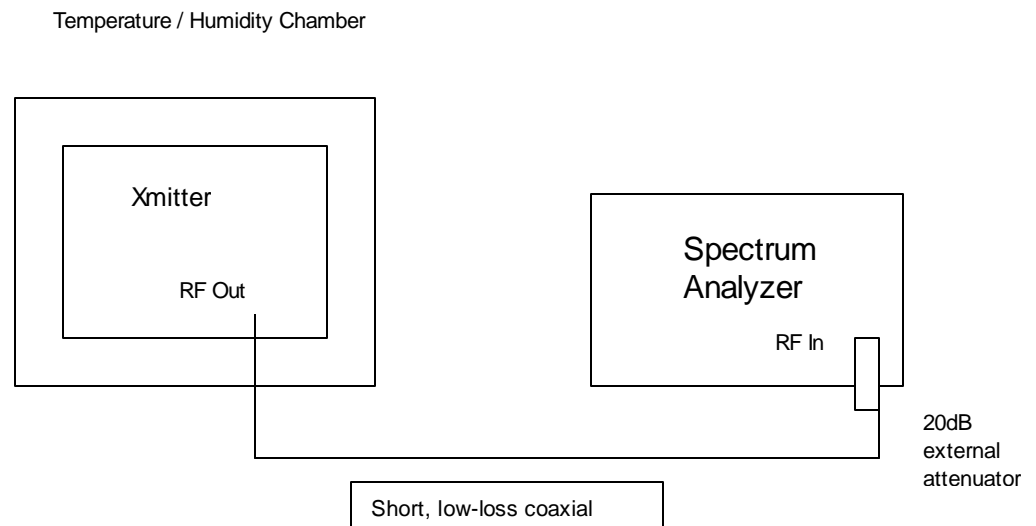

9.1 Test Results

Reference Exhibit "N", file name: Frequency Stability.PDF for the data plots.

10.0 Transient Frequency Behavior

Reference 90.214

The EUT was configured per EIA-603 2.2.19. (Transmitters utilizing digital modulation use a similar configuration – minus the audio inputs, refer to the test setup below):

The 1st spectrum analyzer (test receiver) center frequency was set equal to the transmit frequency. Other analyzer settings: Span = 0Hz, Ref = +10 dBm, RBW = VBW = 30 kHz, FM Demodulation was enabled with a FM Gain = 1kHz.

The Demodulated Output (DOP) of the 1st spectrum analyzer (test receiver) was connected to Channel 1 (vertical input) of the oscilloscope. The time base was set to 10 mS per division and the vertical scale as shown on the test data.

The 2nd spectrum analyzer (RF detector) was set with the following settings: Span = 0Hz, Ref = +10dBm, RBW=VBW=30kHz, no demodulation.

The AUX Video Output of the 2nd spectrum analyzer (RF detector) to Channel 2 (Trigger Input) of the oscilloscope

Channel 2 of the oscilloscope was set to edge trigger when the Xmitter was turned ON or OFF.

The signal generator output was set equal to the transmit frequency, with a frequency modulation of 1kHz and a frequency deviation of +/-25kHz.

The signal generator input to the combiner was set 50 dB below the level of the transmitter input to the combiner.

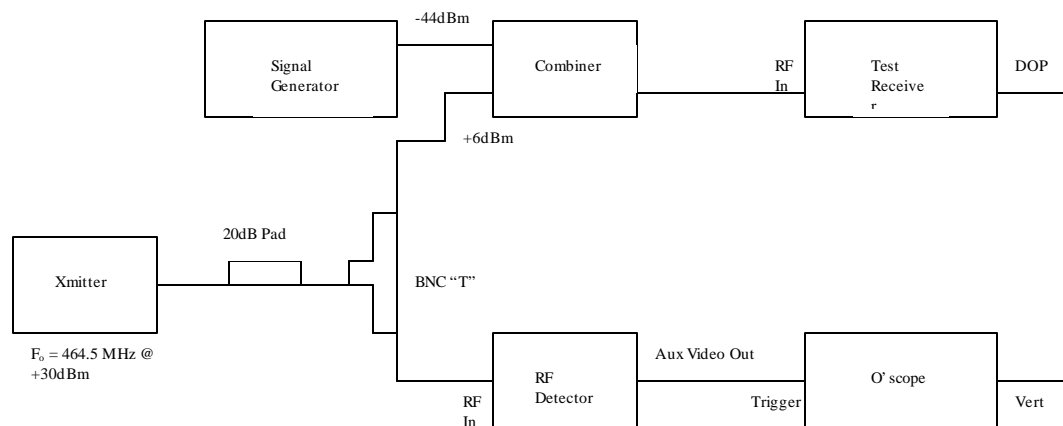

Test Setup

10.1 Test Results

Reference Exhibit "O", file name Transient Frequency Behavior.PDF for the data plots.

11.0 Measurement Equipment

Instrument	Model	Serial No.	Calibration Due
Spectrum Analyzer	HP 8593E	3710A02766	03/31/01
Spectrum Analyzer	HP 8591E	3346A02097	10/08/00
Spectrum Analyzer	HP 8566B	2747A05213	01/19/01
Spectrum Analyzer	HP 8593E	3414U00634	07/01/00
Quasi-Peak Adapter	HP 85650A	2811A01353	01/19/01
Bicon Antenna	EMCO 3141	9906-1146	06/15/00
Pre-Amplifier	AR LN 1000A	25660	07/18/00
Pre-Amplifier	Miteq AMF-4D-005180-24-10	621707	07/18/00
Horn Antenna	EMCO 3115	9804-5441	07/10/00
DC Power Supply	HP 6266B	2549A05642	NCR
AC Power Supply	Instek APS-9050	E991295	NCR
Signal Generator	HP 8648A	3426A00956	04/30/00
Oscilloscope	Tektronix TDS3052	B011236	06/15/00
Combiner/Splitter	Mini Circuits ZA2CS-600-10W	15542	12/27/02

Appendix I – Antenna Specifications



Centurion International, Inc.

Antennas

Mobile Phone Portable Two-Way Wireless Data Satellite

HOME

Antennas



Two-Way Radio (LMR/PMR)

View a Product

Series: EX

Model: EXC

FEATURES

- Injection molded 1/4 wave helical flexible antenna
- High durability, high efficiency
- Textured finish with strain-relief base
- An original 'Tuf Duck' antenna
- Available in various standard connectors

SPECIFICATIONS

FREQUENCY	400-512 MHz 806-960 MHz
POLARIZATION	Vertical
NOMINAL IMPEDANCE	50 ohms
VSWR	1:5:1 max at resonance
RF POWER HANDLING	50 watts
TEMPERATURE RANGE	-40°C to +85°C
DROP TEST	1M Std

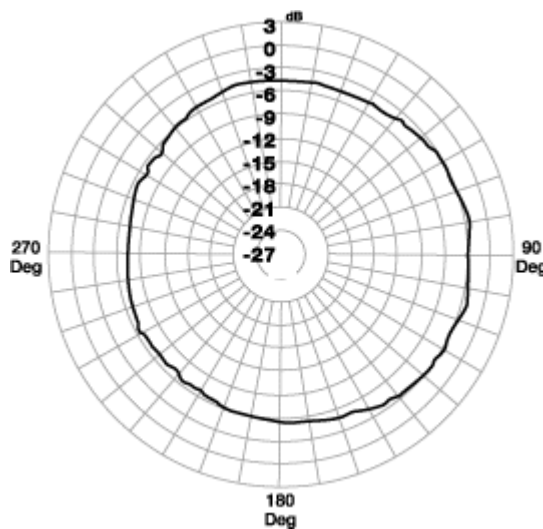

UHF Antenna Performance
User Position, Azimuth Pattern
Test Frequency = 450 MHz
Reference Dipole = 0 dB

FREQUENCIES			
	400-512 MHz	806-960 MHz	960-1850 MHz
BN	6.4 - 7.0	3.6 - 4.6	

How to order:
The EXC model antenna is available in the following frequencies and connectors. Order by antenna model, frequency and connector. For

CONNECTORS	BNX	6.6 - 8.1	3.6 - 4.6
	HT	6.7 - 7.7	3.4 - 4.5
	KR	6.7 - 7.1	3.6 - 4.6
	MD	6.1 - 6.7	3.6 - 4.2
	MX	6.5 - 7.0	3.6 - 4.6
	SF	6.3 - 7.6	3.6 - 3.7
	SFJ	6.2 - 6.9	3.6 - 4.1
	SFU	6.3 - 7.0	3.6 - 4.6
	SM	5.0 - 7.0	3.4 - 4.5
	TN	6.4 - 7.0	3.6 - 4.6
	TNX	6.4 - 7.0	3.6 - 4.6

Call for availability
and lengths

example: EXC450MX.

Estimated length in inches

Specifications subject to change without notice.

[Jump to Custom Design Request Form >>](#)

[Antennas](#) | [Power Products](#) | [About Us](#) | [What's New](#) | [Sales](#) | [Site Map](#)

©1999, Centurion International, Inc.