



# HAC TEST REPORT

**REPORT NO.:** HA960621L09C

**MODEL NO.:** VOGU100

**RECEIVED:** Dec. 28, 2007

**TESTED:** Jan. 05 ~ Jan. 06, 2008

**ISSUED:** Jan. 10, 2008

**APPLICANT:** High Tech Computer Corp.

**ADDRESS:** 23, Hsin-Hua Rd., Taoyuan, 330, Taiwan, R.O.C.

**ISSUED BY:** Advance Data Technology Corporation

**LAB ADDRESS:** No. 47, 14<sup>th</sup> Ling, Chia Pau Tsuen, Lin Kou Hsiang  
244, Taipei Hsien, Taiwan, R.O.C.

**TEST LOCATION:** No. 19, Hwa Ya 2<sup>nd</sup> Rd., Kwei Shan Hsiang, Taoyuan  
Hsien 333, Taiwan, R.O.C.

This test report consists of 32 pages in total except Appendix. It may be duplicated completely for legal use with the approval of the applicant. It should not be reproduced except in full, without the written approval of our laboratory. The client should not use it to claim product endorsement by any government agencies. The test results in the report only apply to the tested sample.



## TABLE OF CONTENTS

1.	CERTIFICATION .....	3
2.	GENERAL INFORMATION.....	4
2.1	GENERAL DESCRIPTION OF EUT .....	4
2.2	DESCRIPTION OF SUPPORT UNITS.....	4
2.3	GENERAL DESCRIPTION OF APPLIED STANDARDS .....	7
3.	GENERAL INFORMATION OF THE DASY4 SYSTEM .....	8
3.1.	GENERAL INFORMATION OF TEST EQUIPMENT .....	8
3.2.	TEST EQUIPMENT LIST .....	12
3.3.	MEASUREMENT UNCERTAINTY .....	13
3.4.	GENERAL DESCRIPTION OF THE HAC EVALUATION .....	14
4.	PERFORMANCE CATEGORIES.....	16
5.	SYSTEM CHECK .....	18
5.1.	VALIDATION STRUCTURE.....	18
5.2.	SYSTEM CHECK PROCEDURE.....	19
5.3.	VALIDATION RESULTS.....	20
6.	MODULATION FACTOR .....	21
6.1	MODULATION FACTOR TEST RESULTS.....	23
7.	RF EMISSION TEST PROCEDURES .....	27
7.1.	TEST INSTRUCTION.....	27
7.2.	TEST PROCEDURES .....	28
7.3.	DESCRIPTION OF TEST POSITION AND CONFIGURATIONS .....	29
7.4.	SUMMARY OF MEASURED HAC RESULTS.....	30
8.	INFORMATION ON THE TESTING LABORATORIES.....	32
	APPENDIX A: TEST CONFIGURATIONS AND TEST DATA	
	APPENDIX B: ADT SAR MEASUREMENT SYSTEM	
	APPENDIX C: PHOTOGRAPHS OF SYSTEM VALIDATION	
	APPENDIX D: SYSTEM CERTIFICATE & CALIBRATION	
	APPENDIX E: TEST CONFIGURATIONS	



## 1. CERTIFICATION

**PRODUCT:** Pocket PC phone  
**MODEL:** VOGU100  
**APPLICANT:** High Tech Computer Corp.  
**TESTED:** Jan. 05 ~ Jan. 06, 2008  
**TEST SAMPLE:** Engineering sample  
**STANDARDS:** **FCC Part 20.19**  
ANSI PC63.19: 2006  
**TEST ITEM:** RF emissions

The above equipment (model: VOGU100) have been tested by **Advance Data Technology Corporation**, and found compliance with the requirement of the above standards. The test record, data evaluation & Equipment Under Test (EUT) configurations represented herein are true and accurate accounts of the measurements of the sample's EMC characteristics under the conditions specified in this report.

**PREPARED BY** : Rennie Wang , **DATE:** Jan. 10, 2008  
Rennie Wang / Senior Specialist

**TECHNICAL ACCEPTANCE** : Stanely Hsu , **DATE:** Jan. 10, 2008  
Responsible for RF Stanely Hsu / Senior Engineer

**APPROVED BY** : Gary Chang , **DATE:** Jan. 10, 2008  
Gary Chang / Supervisor



## 2. GENERAL INFORMATION

### 2.1 GENERAL DESCRIPTION OF EUT

<b>PRODUCT</b>	Pocket PC phone	
<b>MODEL NO.</b>	VOGU100	
<b>FCC ID</b>	NM8VOGU100	
<b>POWER SUPPLY</b>	3.7Vdc from rechargeable lithium battery 5.0Vdc from power adapter 5.0Vdc from host equipment	
<b>CLASSIFICATION</b>	Portable device, production unit	
<b>MODULATION TYPE</b>	Mobile phone: OQPSK, HPSK Bluetooth: GFSK for FHSS	
<b>FREQUENCY RANGE</b>	Mobile phone: 824MHz ~ 849MHz 1850MHz ~ 1910MHz Bluetooth: 2400.0MHz ~ 2483.5MHz	
<b>CHANNEL FREQUENCIES UNDER TEST AND ITS CONDUCTED OUTPUT POWER</b>	SO55 RC3	CDMA850 band: 0.278W (24.44dBm) / 824.7MHz for channel 1013 0.296W (24.71dBm) / 836.5MHz for channel 384 0.279W (24.45dBm) / 848.3MHz for channel 777
	TDSO SO32 RC3	CDMA850 band: 0.269W (24.29dBm) / 824.7MHz for channel 1013 0.283W (24.52dBm) / 836.5MHz for channel 384 0.265W (24.23dBm) / 848.3MHz for channel 777
	1xEVDO	CDMA850 band: 0.266W (24.25dBm) / 824.7MHz for channel 1013
	SO55 RC3	CDMA1900 band: 0.243W (23.86dBm) / 1851.25MHz for channel 25 0.256W (24.08dBm) / 1880.00MHz for channel 600 0.249W (23.96dBm) / 1908.75MHz for channel 1175
	TDSO SO32 RC3	CDMA1900 band: 0.240W (23.81dBm) / 1851.25MHz for channel 25 0.248W (23.95dBm) / 1880.00MHz for channel 600 0.245W (23.89dBm) / 1908.75MHz for channel 1175
	1xEVDO	CDMA1900 band: 0.209W (23.21dBm) / 1908.75MHz for channel 1175
<b>HAC RATE CATEGORY</b>	M3	
<b>ANTENNA TYPE</b>	Mobile phone: Monopole antenna with 0dBi gain Bluetooth: PIFA antenna with 0dBi gain	



<b>DATA CABLE</b>	1.6m USB shielded cable without core
<b>I/O PORTS</b>	Refer to user's manual
<b>ACCESSORY DEVICES</b>	Refer to NOTE below

**NOTE:**

1. This report is issued as a supplementary report to the original ADT report no.: HA960621L09.
2. This report is prepared for FCC class II permissive change. The only difference is changing the CDMA PA. Therefore, test items for CDMA part had been re-tested.
3. The EUT is a CDMA2000 (850/1900) + 1xEVDO/ 1xRTT/ IS-95A/B Pocket PC phone with bluetooth V2.0 w EDR + AGPS functions.
4. The EUT has following accessories.

ACCESSORY	BRAND	MODEL	SUPPORTER	REMARKS
Belt Clip	HTC	PO S292	NEWTECH	
Carrying Case	HTC	PO S290	NEWTECH	
Earphone	HTC	HS S190	Merry	
Splitter (1)	HTC	YC A130	MEC	10.5cm (earphone with audio interface)
Splitter (2)	HTC	YC A100	Acon	9.7cm (earphone with USB interface)

5. The communicated functions of EUT listed as below:

		850MHz	1900MHz	With bluetooth V2.0 w EDR + AGPS functions
3G	CDMA	V	V	
	1xEVDO	V	V	
	1xRTT	V	V	
	IS-95A/B	V	V	

6. The EUT has lithium batteries listed as below:

BATTERY A:	
BRAND:	TWS
MODEL:	ELF0160
RATING:	3.7Vdc, 1100mAh

BATTERY B:	
BRAND:	SAMSUNG
MODEL:	ELF0160
RATING:	3.7Vdc, 1100mAh

**NOTE:** After pre-tested both batteries, found battery A is worse, therefore all the test results came out from this.



7. The EUT was operated with following power adapters:

ADAPTER 1:	
<b>BRAND:</b>	DELTA ELECTRONIC, INC.
<b>MODEL:</b>	ADP-5FH B
<b>INPUT:</b>	100-240Vac, 0.2A, 50~60Hz
<b>OUTPUT:</b>	5Vdc, 1A
<b>POWER LINE:</b>	DC 1.8m non-shielded cable without core

ADAPTER 2:	
<b>BRAND:</b>	htc
<b>MODEL:</b>	PSAA05A-050
<b>INPUT:</b>	100-240Vac, 200mA, 50-60Hz
<b>OUTPUT:</b>	5.0Vdc, 1A
<b>POWER LINE:</b>	DC 1.8m non-shielded cable without core

8. Refer to following table for ESN no.:

ESN NO.
36AD00**

9. The above EUT information was declared by manufacturer and for more detailed features description, please refer to the manufacturer's specifications or User's Manual.



## 2.2 DESCRIPTION OF SUPPORT UNITS

The EUT has been tested as an independent unit together with other necessary accessories or support units. The following support units or accessories were used to form a representative test configuration during the tests.

NO.	PRODUCT	BRAND	MODEL NO.	SERIAL NO.	CALIBRATED UNTIL
1	UNIVERSAL RADIO COMMUNICATION TESTER	R&S	CMU200	104484	Jan. 24, 2008

NO.	SIGNAL CABLE DESCRIPTION OF THE ABOVE SUPPORT UNITS
1	NA

**NOTE:** All power cords of the above support units are non shielded (1.8m).

## 2.3 GENERAL DESCRIPTION OF APPLIED STANDARDS

According to the specifications of the manufacturer, this product must comply with the requirements of the following standards:

**FCC Part 20.19**

**ANSI PC63.19: 2006**

All test items have been performed and recorded as per the above standards.



### 3. GENERAL INFORMATION OF THE DASY4 SYSTEM

#### 3.1. GENERAL INFORMATION OF TEST EQUIPMENT

**DASY4 (software 4.7 Build 53)** consists of high precision robot, probe alignment sensor, phantom, robot controller, controlled measurement server and near-field probe. The robot includes six axes that can move to the precision position of the DASY4 software defined. The DASY4 software can define the area that is detected by the probe. The robot is connected to controlled box. Controlled measurement server is connected to the controlled robot box. The DAE includes amplifier, signal multiplexing, AD converter, offset measurement and surface detection. It is connected to the Electro-optical coupler (ECO). The ECO performs the conversion from the optical into digital electric signal of the DAE and transfers data to the PC.

#### ER3DV6 E-FIELD PROBE

<b>CONSTRUCTION</b>	One dipole parallel, two dipoles normal to probe axis Built-in shielding against static charges
<b>CALIBRATION</b>	In air from 100MHz to 3.0GHz (absolute accuracy $\pm 6.0\%$ , $k = 2$ )
<b>FREQUENCY</b>	100MHz to > 6GHz; Linearity: $\pm 0.2\text{dB}$ (100MHz to 3GHz)
<b>DIRECTIVITY</b>	$\pm 0.2\text{dB}$ in air (rotation around probe axis) $\pm 0.4\text{dB}$ in air (rotation normal to probe axis)
<b>DYNAMIC RANGE</b>	2V/m to > 1000V/m (M3 or better device readings fall well below diode compression point) Linearity: $\pm 0.2\text{dB}$
<b>DIMENSIONS</b>	Overall length: 330mm (Tip: 16mm) Tip diameter: 8mm (Body: 12mm) Distance from probe tip to dipole centers: 2.5mm



## H3DV6 H-FIELD PROBE

<b>CONSTRUCTION</b>	Three concentric loop sensors with 3.8mm loop diameters Resistively loaded detector diodes for linear response Built-in shielding against static charges
<b>FREQUENCY</b>	200MHz to 3GHz (absolute accuracy $\pm 6.0\%$ , $k = 2$ ); Output linearized
<b>DIRECTIVITY</b>	$\pm 0.25\text{dB}$ (spherical isotropy error)
<b>DYNAMIC RANGE</b>	10mA/m to 2A/m at 1GHz (M3 or better device readings fall well below diode compression point)
<b>DIMENSIONS</b>	Overall length: 330mm (Tip: 40mm) Tip diameter: 6mm (Body: 12mm) Distance from probe tip to dipole centers: 3mm
<b>E-FIELD INTERFERENCE</b>	< 10% at 3GHz (for plane wave)

**NOTE:** The Probe parameters have been calibrated by the SPEAG. Please reference "APPENDIX D" for the Calibration Certification Report.

## HAC ARCH

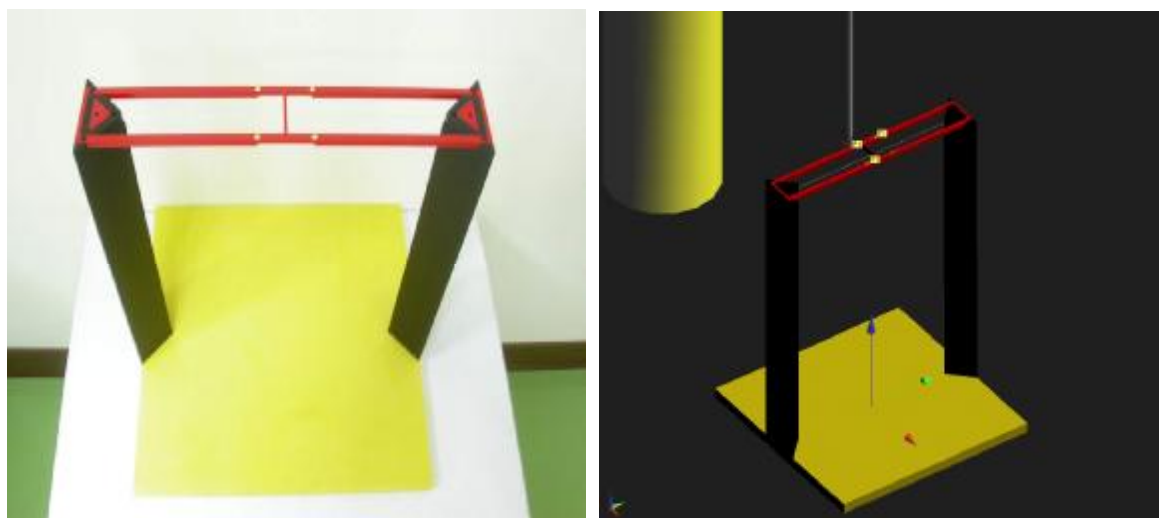

**DIMENSIONS** 370 x 370 x 370mm

## SYSTEM VALIDATION KITS:

- CD835V3**
- Frequency Band:** 800 ~ 960MHz (free space)
  - Return Loss:** > 15dB
  - Calibrated at:** 835MHz
  - Power Capability:** 50W continuous
  - Length & Height:** 166 x 330mm
- CD1880V3**
- Frequency Band:** 1710 ~ 2000MHz (free space)
  - Return Loss:** > 18dB
  - Calibrated at:** 1880MHz
  - Power Capability:** 50W continuous
  - Length & Height:** 80.8 x 330mm
- CD2450V3**
- Frequency Band:** 2250 ~ 2650MHz (free space)
  - Return Loss:** > 18dB
  - Calibrated at:** 2450MHz
  - Power Capability:** 50W continuous
  - Length & Height:** 60 x 330mm



## DEVICE HOLDER



- CONSTRUCTION** Supports accurate and reliable positioning of any phone effect on near field <math>\pm 0.5\text{dB}</math>

## DATA ACQUISITION ELECTRONICS ( DAE )



### CONSTRUCTION

The data acquisition electronics (DAE3) consists of a highly sensitive electrometer grade preamplifier with auto-zeroing, a channel and gain-switching multiplex, a fast 16 bit AD converter and a command decoder and control logic unit. Transmission to the measurement server is accomplished through an optical downlink for data and status information as well as an optical uplink for commands and the clock. The mechanical probe is mounting device includes two different sensor systems for frontal and sideways probe contacts. They are used for mechanical surface detection and probe collision detection. The input impedance of the DAE3 box is 200M $\Omega$ ; the inputs are symmetrical and floating. Common mode rejection is above 80dB.



### 3.2. TEST EQUIPMENT LIST

ITEM	NAME	BAND	TYPE	SERIES NO.	CALIBRATED UNTIL
1	SAM Phantom	S & P	SD HAC P01 BA	1034	NA
2	Robot Positioner	Staubli Unimation	NA	NA	NA
3	Signal Generator	Anritsu	68247B	984703	May 18, 2008
4	E-Field Probe	Speag	ER3DV6	2293	Jan. 22, 2008
5	H-Field Probe	Speag	H3DV6	6124	Jan. 22, 2008
6	DAE	Speag	DAE	579	Mar. 22, 2008
7	Validation Dipole	Speag	CD835V3	1041	May 21, 2008
			CD1880V3	1032	Jul. 17, 2008

**NOTE:** Before starting the measurement, all test equipment shall be warmed up for 30min.

### 3.3. MEASUREMENT UNCERTAINTY

HAC UNCERTAINTY BUDGET ACCORDING TO ANSI C63.19[1]							
ERROR DESCRIPTION	UNCERTAINTY VALUE	PROBABILITY DISTRIBUTION	DIVISOR	( Ci ) E	( Ci ) H	STD. UNC. E	STD. UNC. H
<b>MEASUREMENT SYSTEM</b>							
Probe calibration	±5.1%	Normal	1	1	1	±5.1%	±5.1%
Axial isotropy	±4.7%	Rectangular	√3	1	1	±2.7%	±2.7%
Sensor Displacement	±16.5%	Rectangular	√3	1	0.145	±9.5%	±1.4%
Boundary Effects	±2.4%	Rectangular	√3	1	1	±1.4%	±1.4%
Linearity	±4.7%	Rectangular	√3	1	1	±2.7%	±2.7%
Scaling to Peak Envelope Power	±2.0%	Rectangular	√3	1	1	±1.2%	±1.2%
System Detection Limit	±1.0%	Rectangular	√3	1	1	±0.6%	±0.6%
Readout Electronics	±0.3%	Rectangular	√3	1	1	±0.3%	±0.3%
Response Time	±0.8%	Rectangular	√3	1	1	±0.5%	±0.5%
Integration Time	±2.6%	Rectangular	√3	1	1	±1.5%	±1.5%
RF Ambient Condition	±3.0%	Rectangular	√3	1	1	±1.7%	±1.7%
RF Reflections	±12.0%	Rectangular	√3	1	1	±6.9%	±6.9%
Probe Positioner	±1.2%	Rectangular	√3	1	0.67	±0.7%	±0.5%
Probe Positioning	±4.7%	Rectangular	√3	1	0.67	±2.7%	±1.8%
Extrap. And Interpolation	±1.0%	Rectangular	√3	1	1	±0.6%	±0.6%
<b>TEST SAMPLE RELATED</b>							
Device Positioning Vertical	±4.7%	Rectangular	√3	1	0.67	±2.7%	±1.8%
Device Positioning Lateral	±1.0%	Rectangular	√3	1	1	±0.6%	±0.6%
Device Holder and Phantom	±2.4%	Rectangular	√3	1	1	±1.4%	±1.4%
Power Drift	±5.0%	Rectangular	√3	1	1	±2.9%	±2.9%
<b>PHANTOM AND SETUP RELATED</b>							
Phantom Thickness	±2.4%	Rectangular	√3	1	0.67	±1.4%	±0.9%
<b>COMBINED STD. UNCERTAINTY</b>						±14.7%	±10.9%
<b>EXPANDED STD. UNCERTAINTY ON POWER</b>						±29.4%	±21.8%
<b>EXPANDED STD. UNCERTAINTY ON FIELD</b>						±14.7%	±10.9%

**NOTE:** Worst-case uncertainty budget for HAC free field assessment according to ANSI C63.19 [1]. The budget is valid for the frequency range 800MHz ~ 3GHz and represents a worst-case analysis. For specific tests and configurations, the uncertainty could be considerably smaller.

### 3.4. GENERAL DESCRIPTION OF THE HAC EVALUATION

The DASY4 post-processing software (SEMCAD) automatically executes the following procedures to calculate the field units from the micro-volt readings at the probe connector. The parameters used in the evaluation are stored in the configuration modules of the software:

Probe parameters: - Sensitivity	Norm <sub>i</sub> , a <sub>i0</sub> , a <sub>i1</sub> , a <sub>i2</sub>
- Conversion factor	ConvF <sub>i</sub>
- Diode compression point	dcp <sub>i</sub>
Device parameters: - Frequency	F
- Crest factor	Cf

The first step of the evaluation is a linearization of the filtered input signal to account for the compression characteristics of the detector diode. The compensation depends on the input signal, the diode type and the DC-transmission factor from the diode to the evaluation electronics. If the exciting field is pulsed, the crest factor of the signal must be known to correctly compensate for peak power. The formula for each channel can be given as:

$$V_i = U_i + U_i^2 \cdot \frac{cf}{dcp_i}$$

V <sub>i</sub> = compensated signal of channel i	(i = x, y, z)
U <sub>i</sub> = input signal of channel i	(i = x, y, z)
Cf = crest factor of exciting field	(DASY parameter)
dcp <sub>i</sub> = diode compression point	(DASY parameter)



From the compensated input signals the primary field data for each channel can be evaluated:

$$\textit{E-field probes: } E_i = \sqrt{\frac{V_i}{\text{Norm}_i \cdot \text{ConvF}}}$$

$$\textit{H-field probes: } H_i = \sqrt{V_i} \cdot \frac{a_{i0} + a_{i1}f + a_{i2}f^2}{f}$$

$V_i$  = compensated signal of channel  $i$  ( $i = x, y, z$ )

$\text{Norm}_i$  = sensor sensitivity of channel  $i$   $\mu\text{V}/(\text{V/m})^2$  for E-field Probes ( $i = x, y, z$ )

$\text{ConvF}$  = sensitivity enhancement in solution

$a_{ij}$  = sensor sensitivity factors for H-field probes

$f$  = carrier frequency [GHz]

$E_i$  = electric field strength of channel  $i$  in V/m

$H_i$  = magnetic field strength of channel  $i$  in A/m

The RSS value of the field components gives the total field strength (Hermitian magnitude):

$$E_{tot} = \sqrt{E_x^2 + E_y^2 + E_z^2}$$

The primary field data are used to calculate the derived field units.

$E$  = field strength in V/m

$E_{tot}$  = total field strength in V/m

**NOTE:** The signal response time is evaluated as the time required by the system to reach 90% of the expected final value after an on/off switch of the power source with an integration time of 500ms and a probe response time of < 5ms. In the current implementation, DASY4 waits longer than 100ms after having reached the grid point before starting a measurement, i.e., the response time uncertainty is negligible.

## 4. PERFORMANCE CATEGORIES

The ANSI Standard presents performance requirements for acceptable interoperability of hearing aids with wireless communications devices. When these parameters are met, a hearing aid operates acceptably in close proximity to a wireless communications device.

CATEGORY NEAR FIELD	TELEPHONE RF PARAMETERS < 960MHz				
	AWF	E-FIELD EMISSION CW (dBV/m)	E-FIELD EMISSION CW (V/m)	H-FIELD EMISSION CW (dBA/m)	H-FIELD EMISSION CW (A/m)
M1	0	56.0 to 61.0	631.0 to 1122.0	5.6 to 10.6	1.91 to 3.39
	-5	53.5 to 58.5	473.2 to 841.4	3.1 to 8.1	1.43 to 2.54
M2	0	51.0 to 56.0	354.8 to 631.0	0.6 to 5.6	1.07 to 1.91
	-5	48.5 to 53.5	266.1 to 473.2	-1.9 to 3.1	0.80 to 1.43
M3	0	46.0 to 51.0	199.5 to 354.8	-4.4 to 0.6	0.60 to 1.07
	-5	43.5 to 48.5	149.6 to 266.1	-6.9 to -1.9	0.45 to 0.80
M4	0	< 46.0	< 199.5	< -4.4	< 0.60
	-5	< 43.5	< 149.6	< -6.9	< 0.45

CATEGORY NEAR FIELD	TELEPHONE RF PARAMETERS > 960MHz				
	AWF	E-FIELD EMISSION CW (dBV/m)	E-FIELD EMISSION CW (V/m)	H-FIELD EMISSION CW (dBA/m)	H-FIELD EMISSION CW (A/m)
M1	0	46.0 to 51.0	199.5 to 354.8	-4.4 to 0.6	0.60 to 1.07
	-5	43.5 to 48.5	149.6 to 266.1	-6.9 to -1.9	0.45 to 0.80
M2	0	41.0 to 46.0	112.2 to 199.5	-9.4 to -4.4	0.34 to 0.60
	-5	48.5 to 53.5	84.1 to 149.6	-11.9 to -6.9	0.25 to 0.45
M3	0	36.0 to 41.0	63.1 to 112.2	-14.4 to -9.4	0.19 to 0.34
	-5	33.5 to 38.5	47.3 to 84.1	-16.9 to -11.9	0.14 to 0.25
M4	0	< 36.0	< 63.1	< -14.4	< 0.19
	-5	< 33.5	< 47.3	< -16.9	< 0.14





## ARTICULATION WEIGHING FACTOR (AWF)

The following AWF factors shall be used for the standard transmission protocols:

STANDARD	TECHNOLOGY	AWF (dB)
TIA/EIA/IS-2000	CDMA	0
TIA/EIA-136	TDMA (50Hz)	0
iDENTM	TDMA (22 and 11Hz)	0
J-STD-007	GSM (217)	-5
T1/T1P1/3GPP	UMTS (WCDMA)	0

## 5. SYSTEM CHECK

The measured values (E-field and H-field) were compared with the values provided by the probe manufacturer and must within the allowed tolerance of **25%**.

### 5.1. VALIDATION STRUCTURE

The input signal was an un-modulated continuous wave. The following points were taken into consideration in performing this check:

- Average Input Power  $P = 100\text{mW RMS}$  ( $20\text{dBm RMS}$ ) after adjustment for return loss
- The test fixture must meet the 2 wavelength separation criterion
- The proper measurement of the 1cm probe to dipole separation, which is measured from top surface of the dipole to the calibration reference point of the sensor, defined by the probe manufacturer is shown in the following diagram:

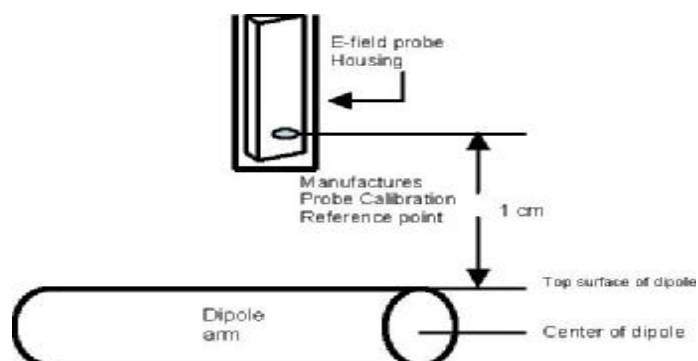

## 5.2. SYSTEM CHECK PROCEDURE

1. Before you start the system performance check, need only to tell the system with which components (probe type, validation dipole and HAC arch) are performing the system performance check; the system will take care of all parameters.

The system check configuration is shown in the following figure:

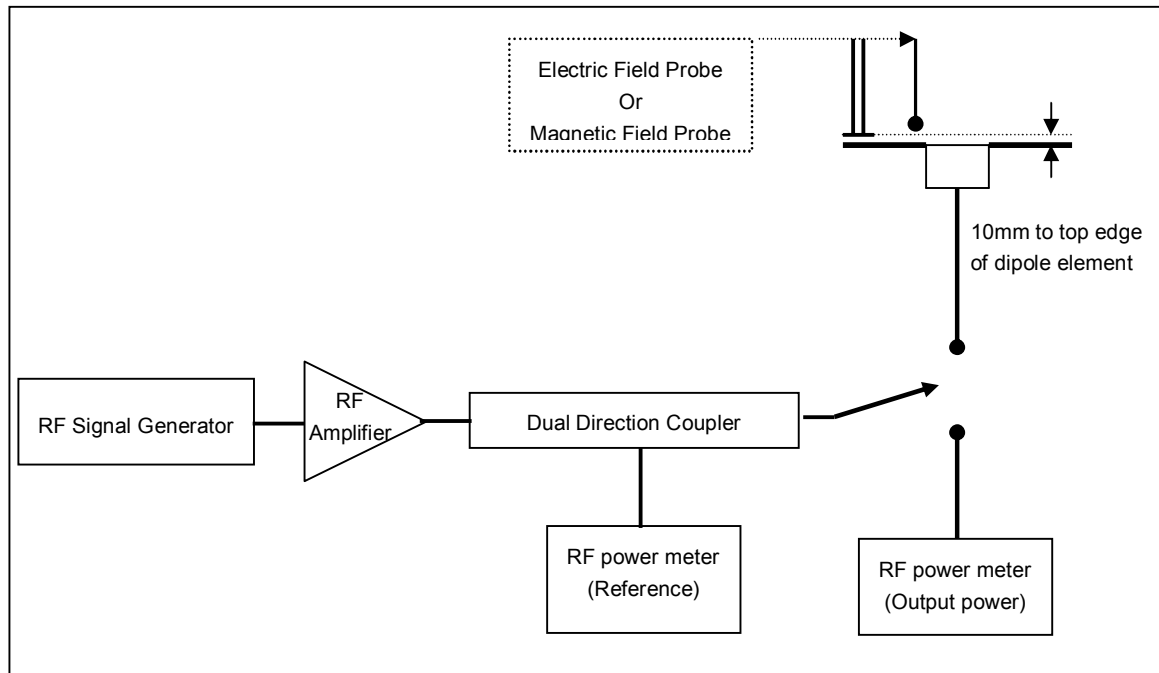

2. The dipole was energized with a 20dBm unmodulated continuous-wave signal.
3. The length of the dipole was scanned with both E-field and H-field probes and the maximum values for each were recorded.



### 5.3. VALIDATION RESULTS

SYSTEM CHECK						
TEST FREQUENCY (MHz)	BEGIN TEST SG POWER (mW)	REQUIRED E-FILED (V/m)	MEASURED E-FILED (V/m)	DEVIATION (%)	SEPARATION DISTANCE (mm)	TESTED DATE
835	100.0	161.7	166.1	2.72	10	Jan. 06, 2008
1880	100.0	137.4	129.6	-5.68	10	Jan. 05, 2008
TEST FREQUENCY (MHz)	BEGIN TEST SG POWER (mW)	REQUIRED H-FILED (V/m)	MEASURED H-FILED (V/m)	DEVIATION (%)	SEPARATION DISTANCE (mm)	TESTED DATE
835	100.0	0.457	0.470	2.84	10	Jan. 06, 2008
1880	100.0	0.454	0.461	1.54	10	Jan. 05, 2008
<b>TESTED BY</b>	Sam Onn					

**NOTE:** Please see Appendix for the system validation test data.

## 6. MODULATION FACTOR

A calibration was made of the modulation response of the probe and its instrumentation chain. This calibration was performed with the field probe, attached to its instrumentation. The response of the probe system to a CW field at the frequency of interest is compared to its response to a modulated signal with equal peak amplitude to that of a CW signal. The field level of the test signals are ensured to be more than 10dB above the ambient level and the noise floor of the instrumentation being used. The ratio of the CW reading to that taken with a modulated reading was applied to the DUT measurements.

### **This was done using the following procedure:**

1. Fixing the probe in a set location relative to a field generating device, such as a reference dipole antenna, as illustrated in the system check procedure.
2. Illuminate the probe using the wireless device connected to the reference dipole with a test signal at the intended measurement frequency, Ensure there is sufficient field coupling between the probe and the antenna so the resulting reading is greater than 10dB above the probe system noise floor but within the systems operating range.
3. Record the amplitude applied to the antenna during transmission and the field strength measured by the E-field probe located near the tip of the dipole antenna.
4. Replace the wireless device with an RF signal generator producing an unmodulated CW signal and set to the wireless device operating frequency.
5. Set the amplitude of the unmodulated signal to equal that recorded from the wireless device.
6. Record the reading of the probe measurement system of the unmodulated signal.
7. The RF signal generator producing an 80%AM signal and set to the wireless device operating frequency. Set the amplitude of the signal to equal that recorded from the wireless device.



8. Record the reading of the probe measurement system of the 80%AM signal.
9. The ratio, in linear units, of the probe reading in Step 6) or 8) to the reading in Step 3) is the E-field modulation factor.
10. Steps 1-9 were repeated at all frequency bands and for both E and H field probes.

**NOTE:** The ratio of the CW to modulated signal reading is the modulation factor. The modulation factors obtained were applied to readings taken of the actual wireless device, in order to obtain an accurate peak field reading using the formula:

$$\text{Peak} = 20 \cdot \log(\text{Raw} \cdot \text{ProbeModulationFactor})$$



## 6.1 MODULATION FACTOR TEST RESULTS

TEST FREQUENCY (MHz)	PROTOCOL	REFERENCE LEVEL	MEASURED E-FILED (V/m)	E-FILED MODULATION FACTOR	TESTED DATE
836.5	CW	Refer to the next three plots	177.5	NA	Jan. 06, 2008
	80% AM		165.1	1.08	
	CDMA		173.1	1.03	
TEST FREQUENCY (MHz)	PROTOCOL	REFERENCE LEVEL	MEASURED H-FILED (A/m)	H-FILED MODULATION FACTOR	TESTED DATE
836.5	CW	Refer to the next three plots	0.502	NA	Jan. 06, 2008
	80% AM		0.469	1.07	
	CDMA		0.491	1.02	
<b>TESTED BY</b>	Sam Onn				

### CW SIGNAL:

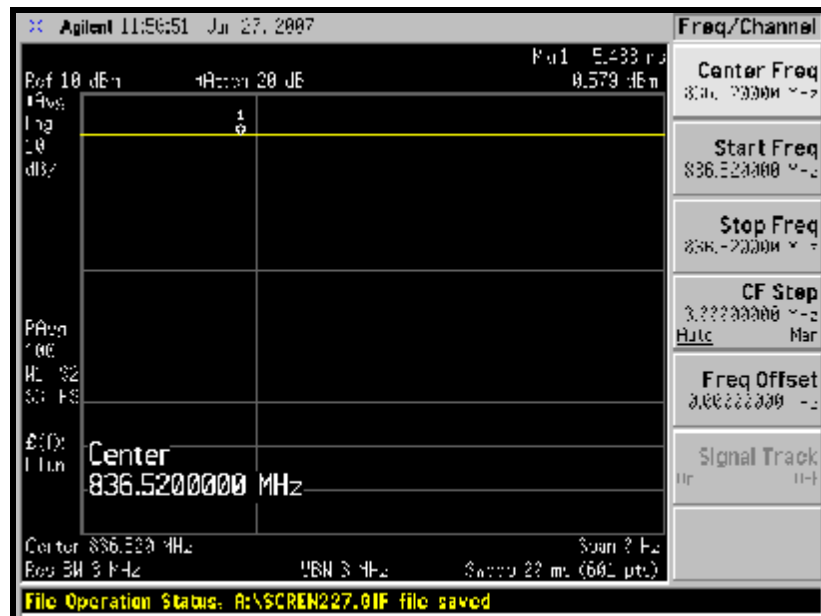

**80% AM SIGNAL:**

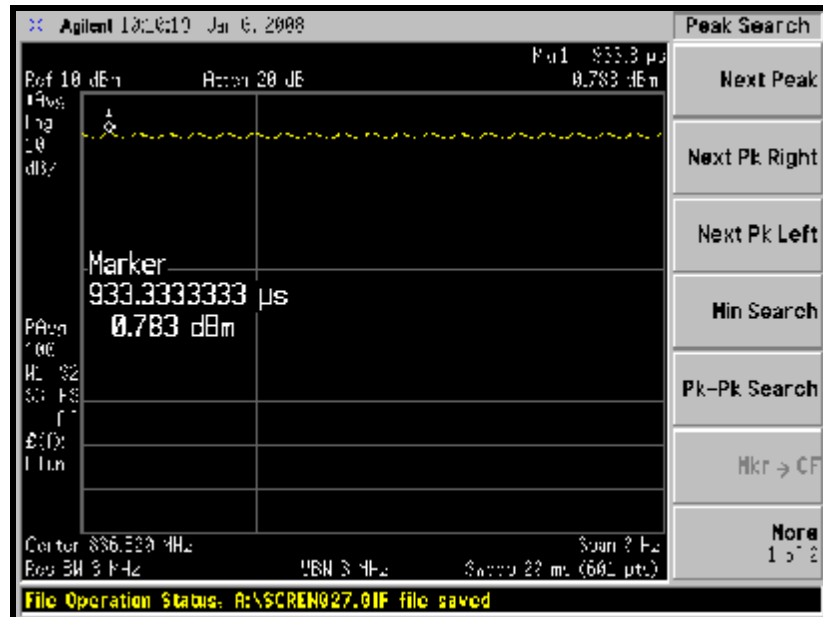

**CDMA SIGNAL:**

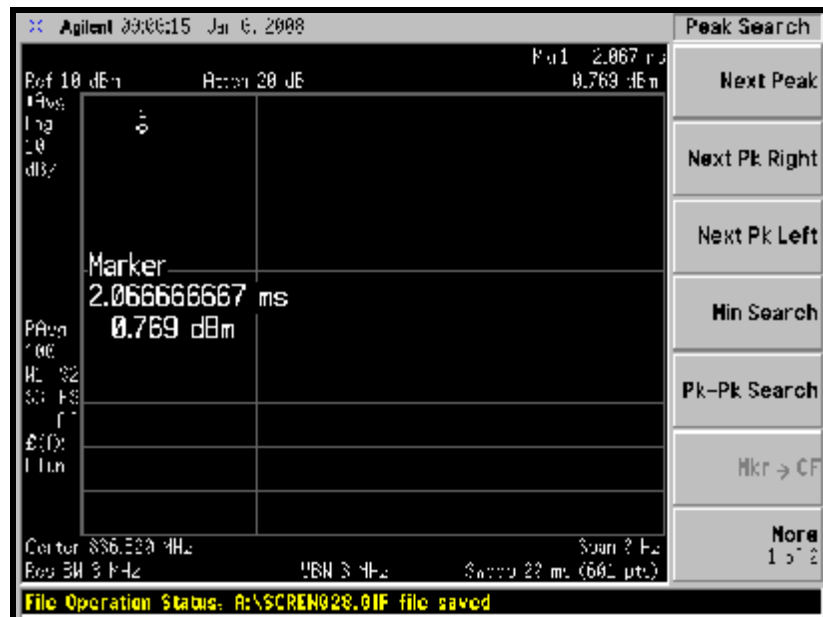





TEST FREQUENCY (MHz)	PROTOCOL	REFERENCE LEVEL	MEASURED E-FILED (V/m)	E-FILED MODULATION FACTOR	TESTED DATE
1880.0	CW	Refer to the next three plots	127.7	NA	Jan. 05, 2008
	80% AM		120.3	1.06	
	CDMA		122.7	1.04	
TEST FREQUENCY (MHz)	PROTOCOL	REFERENCE LEVEL	MEASURED H-FILED (A/m)	H-FILED MODULATION FACTOR	TESTED DATE
1880.0	CW	Refer to the next three plots	0.451	NA	Jan. 05, 2008
	80% AM		0.417	1.08	
	CDMA		0.430	1.05	
<b>TESTED BY</b>	Long Chen				

**CW SIGNAL:**

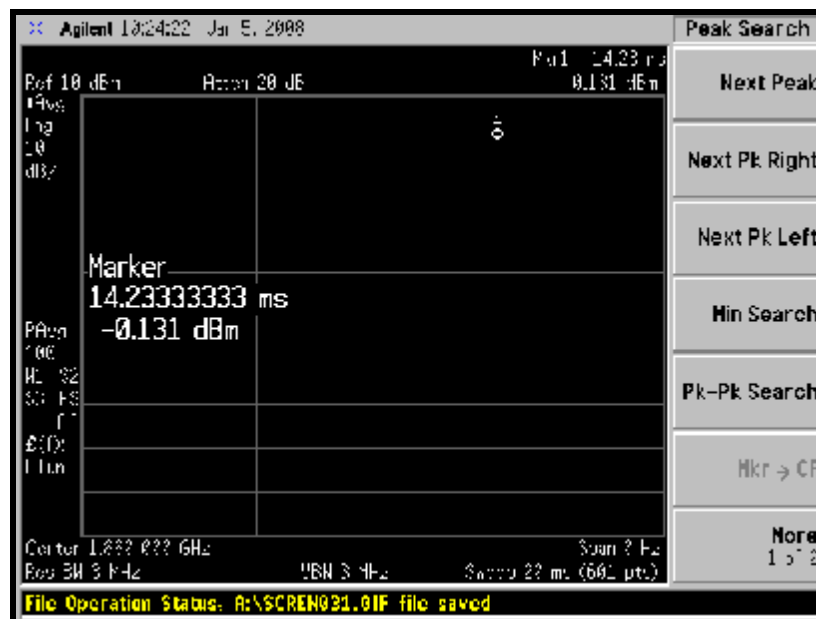

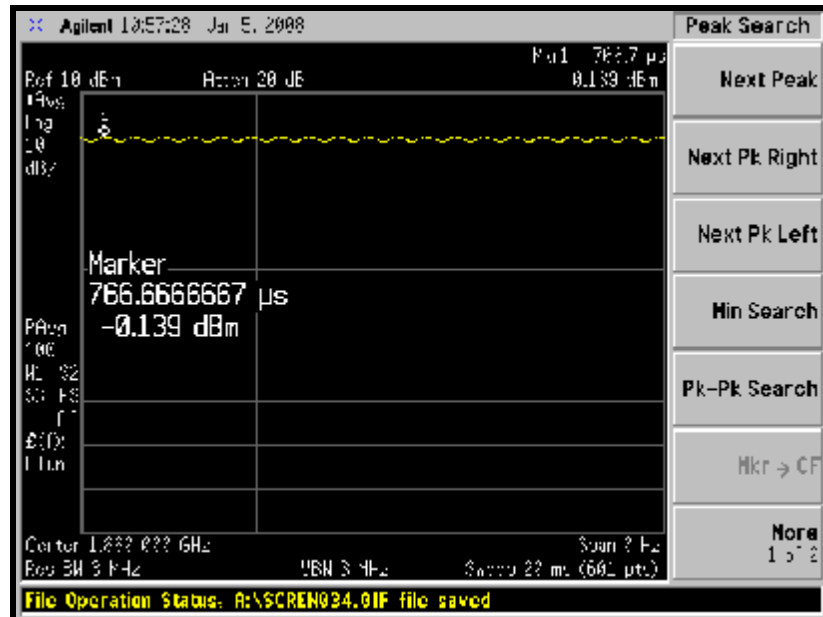
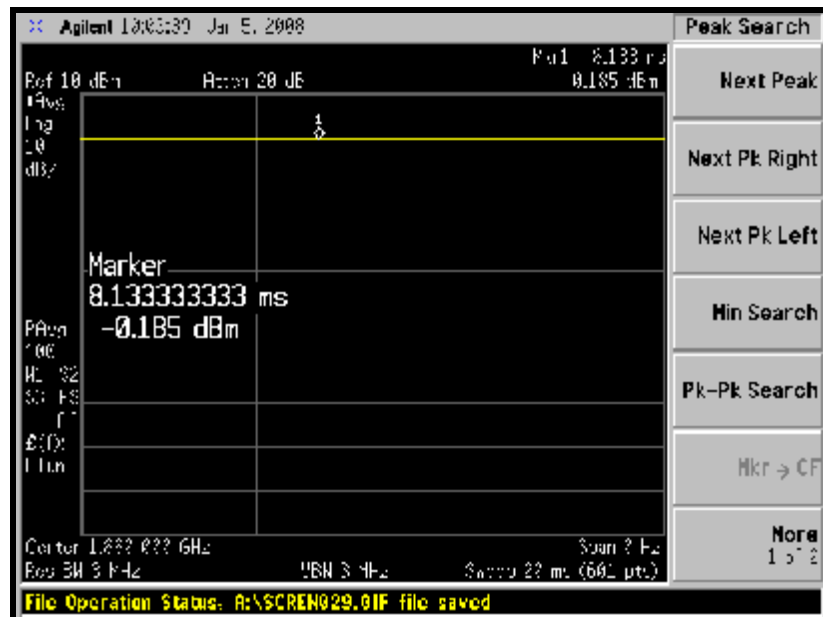
**80% AM SIGNAL:**

**CDMA SIGNAL:**

## 7. RF EMISSION TEST PROCEDURES

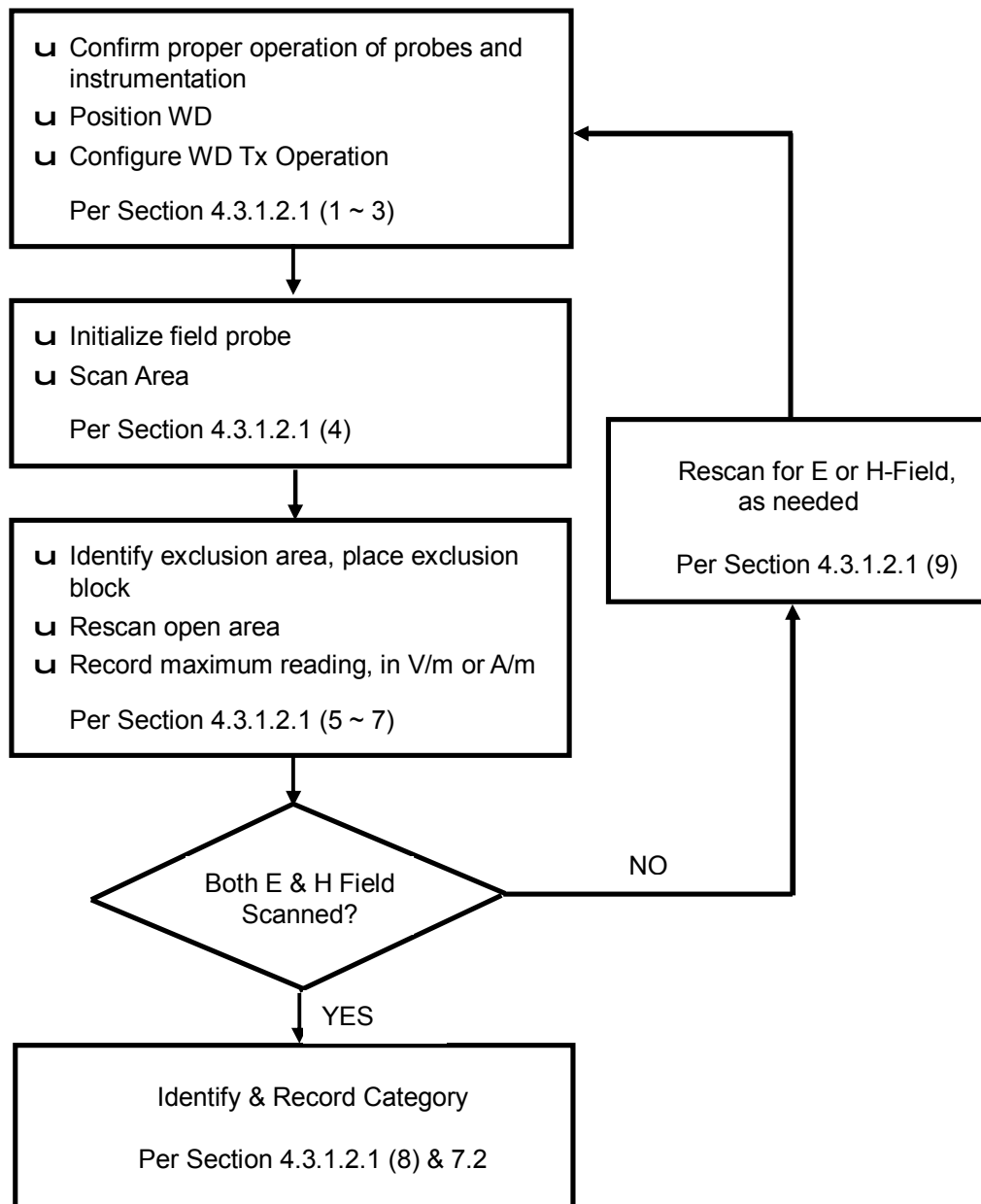
### 7.1. TEST INSTRUCTION



## 7.2. TEST PROCEDURES

The EUT makes a phone call to the GSM base station. Establish the simulation communication configuration rather the actual communication. Then the EUT could continuous the transmission mode. Adjust the PCL of the base station could controlled the EUT to transmitted the maximum output power. The base station also could control the transmission channel.

The recommended procedure for assessing the RF emission value consists of the following steps:

1. Proper operation of the field probe, probe measurement system, other instrumentation, and the positioning system was confirmed.
  2. WD is positioned in its intended test position, acoustic output point of the device perpendicular to the field probe.
  3. The center sub-grid was centered over the center of the acoustic output (also audio band magnetic output, if applicable). The WD audio output was positioned tangent (as physically possible) to the measurement plane.
  4. A surface calibration was performed before each setup change to ensure repeatable spacing and proper maintenance of the measurement plane using the HAC arch.
  5. The measurement system measured the field strength at the reference location.
  6. Measurements at 2mm increments in the 5 x 5cm region were performed and recorded. A 360° rotation about the azimuth axis at the maximum interpolated position was measured. For the worst-case condition, the peak reading from this rotation was used in re-evaluating the HAC category.
  7. Steps 1-6 were done for both the E and H-Field measurements.
-

### 7.3. DESCRIPTION OF TEST POSITION AND CONFIGURATIONS

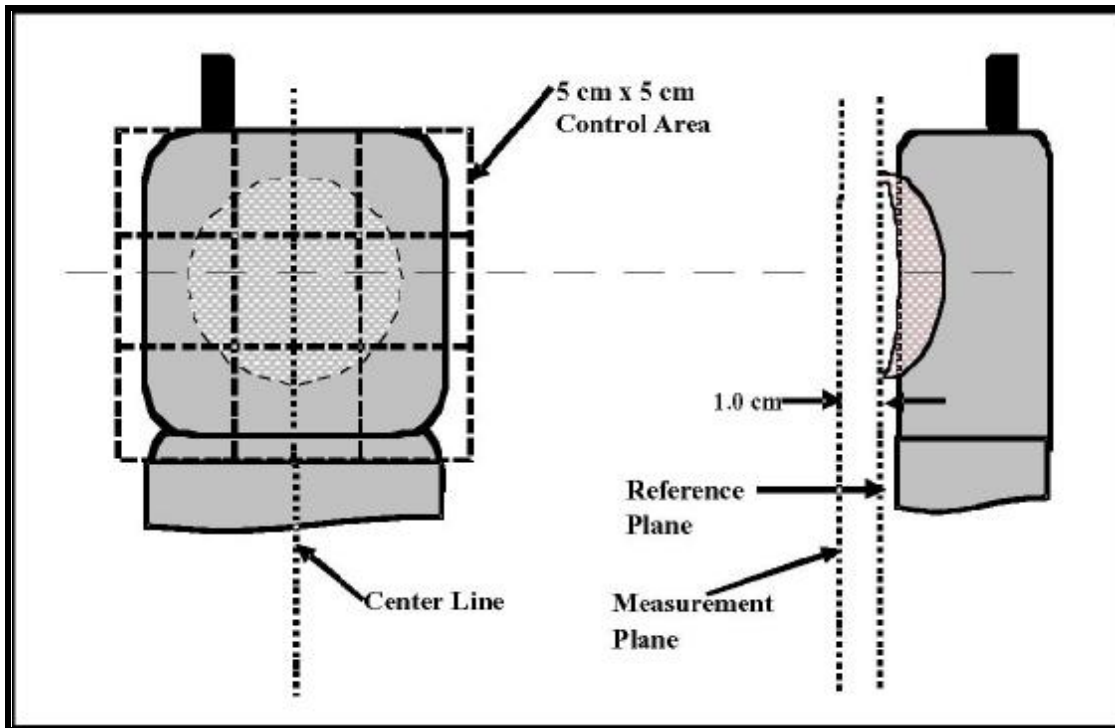



## 7.4. SUMMARY OF MEASURED HAC RESULTS

### E-FIELD EMISSION

ENVIRONMENTAL CONDITION			Air Temperature : 22.1°C, Humidity : 52%RH						
TESTED BY			Sam Onn			DATE		Jan. 06, 2008	
FREQ. (MHz)	CHAN.	MODE	CONDUCTED POWER (dBm)	DRIFT (dB)	MEASURED PMF	EXCLUDED CELLS	PEAK FIELD (V/m)	RATING	
824.70 (Low)	1013	CDMA850	24.44	-0.100	1.03	2, 3, 6	133.3	M4	
836.50 (Mid.)	384		24.71	-0.005		2, 3, 6	114.7	M4	
848.30 (High)	777		24.45	-0.038		2, 3, 6	117.1	M4	
824.70 (Low)	1013	CDMA850 (Battery B)	24.44	-0.014	1.03	2, 3, 6	132.0	M4	
824.70 (Low)	1013	CDMA850 (Light off)	24.44	-0.060	1.03	2, 3, 6	130.7	M4	

ENVIRONMENTAL CONDITION			Air Temperature : 22.1°C, Humidity : 52%RH						
TESTED BY			Sam Onn			DATE		Jan. 05, 2008	
FREQ. (MHz)	CHAN.	MODE	CONDUCTED POWER (dBm)	DRIFT (dB)	MEASURED PMF	EXCLUDED CELLS	PEAK FIELD (V/m)	RATING	
1851.25 (Low)	25	CDMA1900	23.86	-0.103	1.04	6, 8, 9	68.8	M3	
1880.00 (Mid.)	600		24.08	-0.118		6, 8, 9	69.5	M3	
1908.75 (High)	1175		23.96	-0.086		6, 8, 9	70.6	M3	
1908.75 (High)	1175	CDMA1900 (Battery B)	23.96	-0.092	1.04	6, 8, 9	69.0	M3	
1908.75 (High)	1175	CDMA1900 (Light off)	23.96	-0.065	1.04	6, 8, 9	66.2	M3	

**NOTE:**

1. The LCD back-light "ON" & battery A are the worst case for measurement.
2. Please see the Appendix A for the measured data and test plots.
3. The variation of the EUT conducted power measured before and after HAC testing should not over 5%.



### H-FIELD EMISSION

<b>ENVIRONMENTAL CONDITION</b>			Air Temperature : 22.1°C, Humidity : 52%RH					
<b>TESTED BY</b>			Sam Onn		<b>DATE</b>		Jan. 06, 2008	
FREQ. (MHz)	CHAN.	MODE	CONDUCTED POWER (dBm)	DRIFT (dB)	MEASURED PMF	EXCLUDED CELLS	PEAK FIELD (A/m)	RATING
824.70 (Low)	1013	CDMA850	24.44	-0.001	1.02	4, 7, 8	0.468	M4
836.50 (Mid.)	384		24.71	-0.041		4, 7, 8	0.404	M4
848.30 (High)	777		24.45	-0.005		4, 7, 8	0.410	M4
824.70 (Low)	1013	CDMA850 (Battery B)	24.44	-0.113	1.02	4, 7, 8	0.462	M4
824.70 (Low)	1013	CDMA850 (Light off)	24.44	-0.039	1.02	4, 7, 8	0.458	M4

<b>ENVIRONMENTAL CONDITION</b>			Air Temperature : 22.1°C, Humidity : 52%RH					
<b>TESTED BY</b>			Sam Onn		<b>DATE</b>		Jan. 05, 2008	
FREQ. (MHz)	CHAN.	MODE	CONDUCTED POWER (dBm)	DRIFT (dB)	MEASURED PMF	EXCLUDED CELLS	PEAK FIELD (A/m)	RATING
1851.25 (Low)	25	CDMA1900	23.86	-0.318	1.05	6, 8, 9	0.149	M4
1880.00 (Mid.)	600		24.08	-0.086		6, 8, 9	0.164	M4
1908.75 (High)	1175		23.96	-0.319		6, 8, 9	0.214	M3
1908.75 (High)	1175	CDMA1900 (Battery B)	23.96	-0.216	1.05	6, 8, 9	0.211	M3
1908.75 (High)	1175	CDMA1900 (Light off)	23.96	-0.330	1.05	6, 8, 9	0.208	M3

**NOTE:**

1. The LCD back-light "ON" & battery A are the worst case for measurement.
2. Please see the Appendix A for the measured data and test plots.
3. The variation of the EUT conducted power measured before and after HAC testing should not over 5%.



## 8. INFORMATION ON THE TESTING LABORATORIES

We, ADT Corp., were founded in 1988 to provide our best service in EMC, Radio, Telecom and Safety consultation. Our laboratories are accredited and approved by the following approval agencies according to ISO/IEC 17025.

<b>USA</b>	FCC, UL, A2LA
<b>GERMANY</b>	TUV Rheinland
<b>JAPAN</b>	VCCI
<b>NORWAY</b>	NEMKO
<b>CANADA</b>	INDUSTRY CANADA , CSA
<b>R.O.C.</b>	TAF, BSMI, NCC
<b>NETHERLANDS</b>	Telefication
<b>SINGAPORE</b>	GOST-ASIA (MOU)
<b>RUSSIA</b>	CERTIS (MOU)

Copies of accreditation certificates of our laboratories obtained from approval agencies can be downloaded from our web site:

[www.adt.com.tw/index.5/phtml](http://www.adt.com.tw/index.5/phtml). If you have any comments, please feel free to contact us at the following:

**Linko EMC/RF Lab:**

Tel: 886-2-26052180

Fax: 886-2-26051924

**Hsin Chu EMC/RF Lab:**

Tel: 886-3-5935343

Fax: 886-3-5935342

**Hwa Ya EMC/RF/Safety/Telecom Lab:**

Tel: 886-3-3183232

Fax: 886-3-3185050

**Web Site:** [www.adt.com.tw](http://www.adt.com.tw)

The address and road map of all our labs can be found in our web site also.